

## HELICAL OIL SEPARATORS & RESERVOIRS



### Product introduction ;

The function of a Helical Oil Separator is to efficiently remove oil from the discharge gas and return it to the compressor crankcase in a proper and precise manner.

This helps maintain the oil level of the compressor crankcase and raises the efficiency of the system by preventing excessive oil circulation.

Helical oil separators provide a higher level of efficiency compared to a conventional oil separator with float mechanism.

Helical oil separators can be used in a wide variety of applications.

Helical oil separators are intended for low pressure oil management systems, but they can also be used in high pressure oil management systems.

These oil separators are designed for use with scroll and reciprocating type compressors.

They are not suitable to use with screw compressors.

There is an oil reservoir in the lower chamber of the helical oil separators.

1 unit of 3/8" SAE rotalack valve is supplied as installed on each reservoir to facilitate easy control of the oil fill and drain.

Oil reservoirs have 2 sight glasses for visual indication of the oil level. Sight glasses are designed considering minimum and maximum levels.

Level indicator balls in the sight glass provide great convenience to see the oil level.

With proper selection, oil separation efficiency is typically 95%.

# HELICAL OIL SEPARATORS & RESERVOIRS



▶ Type (A)

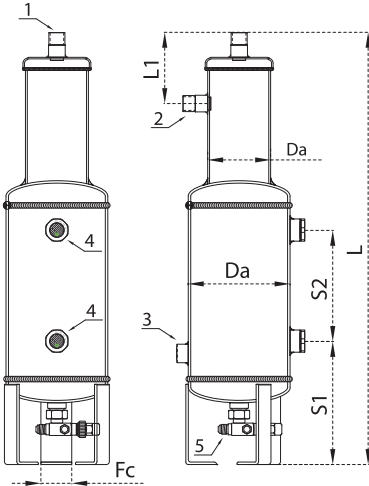

▶ Type (B)

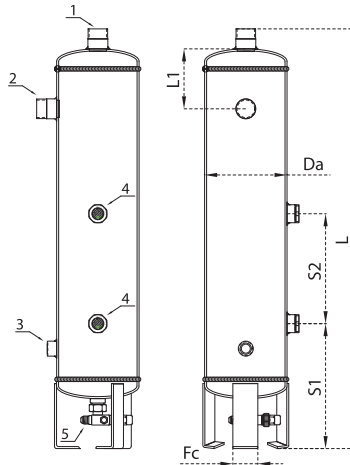

▶ Type (C)

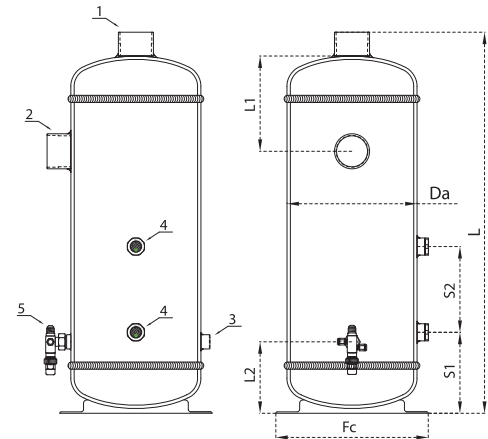

- ▶ 1 Outlet Connection
- ▶ 2 Inlet Connection
- ▶ 3 Oil Level Sensor Connection
- ▶ 4 Sight Glass
- ▶ 5 Oil Return, Rotalack valve, 3/8 SAE Flare

Model	Volume (Lt)	Dimensions					Type	Connection Sizes				CE	
		Da (mm)	L (mm)	L1 (mm)	L2 (mm)	Fc (mm)		Inlet & Outlet (Inch)	Oil Reservoir Outlet (Inch)	sv (Inch)	Sight Glass	PED 33 Bar	97/23/EC 45 Bar
OS/OR/A-7/8	6,8	Ø165	700	115	-	-	A	7/8" ODS	-	-	-	-	-
OS/OR/A-1 1/8		Ø140						11/8" ODS					
OS/OR/B-1 3/8	13,2	Ø165	840	160	-	Ø125	B	13/8" ODS	Rotalack Valve 3/8" SAE Flare	1/2" NPTF	SW36 with Swimming Ball	CAT II / A1	CAT II / A1
OS/OR/B-1 5/8			845	165				15/8" ODS					
OS/OR/B-2 1/8			900	170				21/8" ODS					
OS/OR/C-2 1/8	21,5	Ø219	700	200	120	Ø249	C	21/8" ODS	-	-	-	CAT III / B+C1	CAT III / B+C1
OS/OR/C-2 5/8	38,3	Ø273	800	250	150	25/8" ODS							
OS/OR/C-3 1/8	54,7	Ø324	830	300	170	31/8" ODS							

Model	kW							Maximum Discharge Volume (m3/hr)
	Capacity In kW Of Refrigeration At Nominal Evaporator Temperature							
	R404A / 507		R22		R717			
	-40° C	5° C	-40° C	5° C	-40° C	5° C		
OS/OR/A-7/8	26,8	33,4	27,1	31,0	N/A	N/A	12,6	
OS/OR/A-1 1/8	44,4	55,3	44,9	51,3	N/A	N/A	20,8	
OS/OR/B-1 3/8	66,3	82,6	67,0	76,6	N/A	N/A	31,0	
OS/OR/B-1 5/8	92,6	115,3	93,6	107,0	94,03	125,38	43,3	
OS/OR/B-2 1/8	96,8	120,5	97,8	111,8	98,27	131,02	45,3	
OS/OR/C-2 1/8	205,8	236,7	208,8	219,5	214,40	257,28	74,1	
OS/OR/C-2 5/8	241,6	301,0	244,3	279,2	N/A	N/A	113,1	
OS/OR/C-3 1/8	342,4	426,6	346,2	395,7	N/A	N/A	160,2	

All data is for a 38° C condensing temperature, 18° C suction temperature and a connection size the same as the compressor discharge valve