



BY JOHNSON CONTROLS

## AIR-COOLED SCREW LIQUID CHILLERS

INSTALLATION, OPERATION & MAINTENANCE

Supersedes 201.23-NM1 (510)

Form 201.23-NM1 (910)

035-21506-100

# LATITUDE™

## AIR-COOLED SCREW LIQUID CHILLERS STYLE A

### MODELS

YCIV0590-1500, 50 HZ  
(590 -1500 KW)

E/V HIGH EFFICIENCY AND S/P STANDARD EFFICIENCY



R134a

# IMPORTANT!

## READ BEFORE PROCEEDING!

### GENERAL SAFETY GUIDELINES

This equipment is a relatively complicated apparatus. During installation, operation, maintenance or service, individuals may be exposed to certain components or conditions including, but not limited to refrigerants, oils, materials under pressure, rotating components, and both high and low voltage. Each of these items has the potential, if misused or handled improperly, to cause bodily injury or death. It is the obligation and responsibility of operating/service personnel to identify and recognize these inherent hazards, protect themselves, and proceed safely in completing their tasks. Failure to comply with any of these requirements could result in serious damage to the equipment and the property in

which it is situated, as well as severe personal injury or death to themselves and people at the site.

This document is intended for use by owner-authorized operating/service personnel. It is expected that this individual possesses independent training that will enable them to perform their assigned tasks properly and safely. It is essential that, prior to performing any task on this equipment, this individual shall have read and understood this document and any referenced materials. This individual shall also be familiar with and comply with all applicable governmental standards and regulations pertaining to the task in question.

### SAFETY SYMBOLS

The following symbols are used in this document to alert the reader to areas of potential hazard:



***DANGER*** indicates an imminently hazardous situation which, if not avoided, will result in death or serious injury.



***CAUTION*** identifies a hazard which could lead to damage to the machine, damage to other equipment and/or environmental pollution. Usually an instruction will be given, together with a brief explanation.



***WARNING*** indicates a potentially hazardous situation which, if not avoided, could result in death or serious injury.

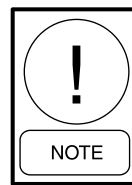

***NOTE*** is used to highlight additional information which may be helpful to you.



***External wiring, unless specified as an optional connection in the manufacturer's product line, is NOT to be connected inside the Micro Panel cabinet. Devices such as relays, switches, transducers and controls may NOT be installed inside the panel. NO external wiring is allowed to be run through the Micro Panel. All wiring must be in accordance with Johnson Controls published specifications and must be performed ONLY by qualified Johnson Controls personnel. Johnson Controls will not be responsible for damages/problems resulting from improper connections to the controls or application of improper control signals. Failure to follow this will void the manufacturer's warranty and cause serious damage to property or injury to persons.***

## CHANGEABILITY OF THIS DOCUMENT

In complying with Johnson Controls policy for continuous product improvement, the information contained in this document is subject to change without notice. While Johnson Controls makes no commitment to update or provide current information automatically to the manual owner, that information, if applicable, can be obtained by contacting the nearest Johnson Controls Engineered Systems Service office.

It is the responsibility of operating/service personnel to verify the applicability of these documents to the equipment in question. If there is any question in the mind of operating/service personnel as to the applicability of these documents, then prior to working on the equipment, they should verify with the owner whether the equipment has been modified and if current literature is available.



***The Control/VSD Cabinet contains lethal high AC and DC voltages. Before performing service inside the cabinet, remove the AC supply feeding the chiller and verify using a non-contact voltage sensor.***



***The DC voltage on the VSD DC Bus will take 5 minutes to bleed off, after AC power is removed. Always check the DC Bus Voltage with a Voltmeter to assure the capacitor charge has bled off before working on the system.***



***NEVER short out the DC Bus to discharge the filter capacitors.***



***NEVER place loose tools, debris, or any objects inside the Control Panel/VSD Cabinet.***



***NEVER allow the Control Panel VSD Cabinet doors to remain open if there is a potential for rain to enter the panel. Keep doors closed and assure all latches are engaged on each door unless the unit is being serviced.***



***ALWAYS lockout the disconnect supplying AC to the chiller.***



***The 1L Line Inductor will reach operating temperatures of over 300° F. DO NOT open panel doors during operation. Assure the inductor is cool whenever working near the inductor with power OFF.***

**THIS PAGE INTENTIONALLY LEFT BLANK**

## TABLE OF CONTENTS

<b>SECTION 1 - GENERAL CHILLER INFORMATION AND SAFETY .....</b>	<b>21</b>
<b>INTRODUCTION .....</b>	<b>21</b>
<b>WARRANTY .....</b>	<b>21</b>
<b>SAFETY .....</b>	<b>21</b>
Standards for Safety .....	21
Responsibility for Safety .....	21
<b>ABOUT THIS MANUAL.....</b>	<b>22</b>
<b>MISUSE OF EQUIPMENT .....</b>	<b>22</b>
Suitability for Application .....	22
Structural Support.....	22
Mechanical Strength .....	22
General Access.....	22
Pressure Systems .....	22
Electrical.....	23
Rotating Parts .....	23
Sharp Edges.....	23
Refrigerants and Oils .....	23
High Temperature and Pressure Cleaning .....	23
Emergency Shutdown.....	23
<b>SECTION 2 - PRODUCT DESCRIPTION .....</b>	<b>25</b>
<b>INTRODUCTION .....</b>	<b>25</b>
General System Description.....	25
Compressor .....	26
Evaporator.....	27
Condenser.....	27
Flash Tank Feed Valve/Drain Valves .....	28
Oil Separator/Oil System .....	28
Relief Valves.....	28
Oil Cooling .....	29
Capacity Control.....	29
Power and Control Panel .....	29
Each Power Compartment Contains .....	29
Microprocessor and VSD Controls .....	29
Display.....	29
Keypad.....	30
Unit Switch .....	30
Variable Speed Drive (VSD) .....	31

## TABLE OF CONTENTS (CONT'D)

<b>ACCESSORIES AND OPTIONS .....</b>	<b>32</b>
Sound Reduction Options .....	32
Condenser Coil Protection .....	33
Protective Chiller Panels .....	33
Evaporator Options .....	34
General Options .....	34
Vibration Isolation .....	34
<b>UNIT MODEL NUMBER NOMENCLATURE.....</b>	<b>35</b>
<b>COMPLETE PIN NUMBER DESCRIPTION.....</b>	<b>36</b>
<b>SECTION 3 - HANDLING AND STORAGE .....</b>	<b>41</b>
DELIVERY AND STORAGE.....	41
INSPECTION .....	41
MOVING THE CHILLER.....	41
Lifting Weights.....	41
Unit Rigging .....	42
<b>SECTION 4 - INSTALLATION .....</b>	<b>45</b>
LOCATION REQUIREMENTS.....	45
OUTDOOR INSTALLATIONS .....	45
INDOOR INSTALLATIONS .....	45
LOCATION CLEARANCES.....	45
VIBRATION ISOLATORS.....	46
Installation.....	46
SHIPPING BRACES.....	46
CHILLED LIQUID PIPING .....	46
General Requirements .....	46
WATER TREATMENT .....	47
REFRIGERANT RELIEF VALVE PIPING.....	48
PIPEWORK ARRANGEMENT .....	48
CONNECTION TYPES AND SIZES .....	48
COOLER CONNECTIONS .....	48
Option Flanges .....	48
DUCTWORK CONNECTION .....	49
General Requirements .....	49
ELECTRICAL CONNECTION .....	49
POWER WIRING .....	50
POWER SUPPLY WIRING .....	50
115VAC CONTROL SUPPLY TRANSFORMER .....	50
CONTROL PANEL WIRING .....	50
VOLTS FREE CONTACTS .....	51
Chilled Liquid Pump Starter .....	51
Run Contact .....	51
Alarm Contacts .....	51

## TABLE OF CONTENTS (CONT'D)

<b>SYSTEM INPUTS .....</b>	<b>51</b>
Flow Switch.....	51
Remote Run / Stop .....	51
Remote Print .....	51
Optional Remote Setpoint Offset – Temperature .....	51
Optional Remote Setpoint Offset – Current .....	51
Optional Remote Setpoint Offset – Sound Limiting .....	51
<b>SECTION 5 - COMMISSIONING .....</b>	<b>53</b>
<b>PREPARATION .....</b>	<b>53</b>
<b>PREPARATION – GENERAL.....</b>	<b>53</b>
Inspection .....	53
Refrigerant Charge .....	53
Service and Oil Line Valves .....	53
Compressor Oil.....	53
Fans .....	53
Isolation / Protection .....	53
Control Panel .....	53
Power Connections .....	53
Grounding .....	54
Water System .....	54
Flow Switch.....	54
Temperature Sensor(s) .....	54
Programmed Options.....	54
Programmed Settings .....	54
Date and Time .....	54
Start/Stop Schedule .....	54
Setpoint and Remote Offset .....	54
<b>FIRST TIME START-UP .....</b>	<b>54</b>
Interlocks.....	54
Unit Switch .....	55
Start-up.....	55
Oil Pressure .....	55
Refrigerant Flow .....	55
Loading.....	55
Condenser and Fan Rotation .....	55
Suction Superheat.....	55
Subcooling .....	55
General Operation .....	55
<b>EQUIPMENT PRE-STARTUP AND STARTUP CHECKLIST .....</b>	<b>56</b>
Pre Start-up.....	56
Start-up .....	58

## TABLE OF CONTENTS (CONT'D)

<b>SECTION 6 - TECHNICAL DATA .....</b>	<b>63</b>
<b>WATER PRESSURE DROP CHARTS .....</b>	<b>63</b>
<b>GLYCOL CORRECTION FACTORS .....</b>	<b>67</b>
<b>WATER TEMPERATURE AND FLOWS.....</b>	<b>68</b>
<b>WATER TEMPERATURE AND FLOWS (CONT'D) .....</b>	<b>69</b>
<b>PHYSICAL DATA (ENGLISH - STANDARD EFFICIENCY).....</b>	<b>70</b>
<b>PHYSICAL DATA (ENGLISH - HIGH EFFICIENCY).....</b>	<b>72</b>
<b>PHYSICAL DATA (SI - STANDARD EFFICIENCY) .....</b>	<b>74</b>
<b>PHYSICAL DATA (SI - HIGH EFFICIENCY) .....</b>	<b>76</b>
<b>ELECTRICAL DATA.....</b>	<b>78</b>
<b>2 Compressor Power Wiring Connections.....</b>	<b>78</b>
<b>3 Compressor Power Wiring Connections.....</b>	<b>79</b>
<b>ELECTRICAL NOTES .....</b>	<b>92</b>
<b>ELECTRICAL WIRING DIAGRAMS - 2 COMPRESSOR MODELS.....</b>	<b>94</b>
<b>Elementary Power Wiring Diagram .....</b>	<b>96</b>
<b>Power Wiring Connection Diagram .....</b>	<b>98</b>
<b>Control Wiring Connection Diagram .....</b>	<b>100</b>
<b>Power Elementary Wiring Diagram.....</b>	<b>103</b>
<b>Location Label .....</b>	<b>105</b>
<b>ELECTRICAL WIRING DIAGRAMS - 3 COMPRESSOR MODELS.....</b>	<b>108</b>
<b>Panel Layout .....</b>	<b>108</b>
<b>Elementary Control Wiring Diagram.....</b>	<b>109</b>
<b>Control Elementary Diagram.....</b>	<b>111</b>
<b>Power Elementary Diagram .....</b>	<b>113</b>
<b>Control Wiring Connection Diagram .....</b>	<b>115</b>
<b>Power Wiring Connection Diagram .....</b>	<b>118</b>
<b>Location Label .....</b>	<b>124</b>
<b>Panel Layout .....</b>	<b>125</b>
<b>DIMENSIONS - 2 AND 3 COMPRESSOR SI.....</b>	<b>126</b>
<b>TECHNICAL DATA - CLEARANCES.....</b>	<b>146</b>
<b>ISOLATOR INFORMATION FOR UNITS SHIPPED ON OR AFTER JUNE 15, 2008 .....</b>	<b>147</b>
<b>Isolator Selection and Mounting .....</b>	<b>147</b>
<b>One Inch Deflection Spring Isolators Cross-reference.....</b>	<b>164</b>
<b>One Inch Deflection Spring Isolators Installation Instructions.....</b>	<b>165</b>
<b>Durulene Isolator Cross-reference .....</b>	<b>166</b>
<b>Installation of Durulene Vibration Isolators .....</b>	<b>167</b>
<b>Seismic Isolator Cross-reference .....</b>	<b>168</b>
<b>Seismic Isolator Installation and Adjustment.....</b>	<b>169</b>

## TABLE OF CONTENTS (CONT'D)

<b>ISOLATOR INFORMATION FOR UNITS SHIPPED BEFORE JUNE 15, 2008 .....</b>	<b>170</b>
<b>SLRS Seismic Isolator Specifications .....</b>	<b>170</b>
<b>SLRS Seismic Isolator Installation and Adjustment .....</b>	<b>171</b>
<b>ND-X Neoprene Isolator Specifications .....</b>	<b>172</b>
<b>CIP 1" Deflection Restrained Mounting Specifications .....</b>	<b>173</b>
<b>Installation of 1" Deflection Mounts .....</b>	<b>174</b>
<b>REFRIGERANT FLOW DIAGRAM .....</b>	<b>175</b>
<b>PROCESS AND INSTRUMENTATION DIAGRAM .....</b>	<b>176</b>
<b>COMPONENT LOCATIONS.....</b>	<b>177</b>
<b>GLYCOL SYSTEM COMPONENTS.....</b>	<b>198</b>
<b>COMPRESSOR COMPONENTS .....</b>	<b>200</b>
<b>CHILLER ELECTRONIC COMPONENTS .....</b>	<b>201</b>
<b>Keypad.....</b>	<b>201</b>
<b>Display.....</b>	<b>202</b>
<b>Relay Output Boards.....</b>	<b>203</b>
<b>VSD (Variable Speed Drive) .....</b>	<b>204</b>
<b>AC to DC Rectifier .....</b>	<b>204</b>
<b>SCR Trigger Board .....</b>	<b>204</b>
<b>DC Link Filter .....</b>	<b>204</b>
<b>1L Line Inductor .....</b>	<b>205</b>
<b>DC to AC Inverter.....</b>	<b>205</b>
<b>Laminated Bus Structure.....</b>	<b>206</b>
<b>VSD Logic Board .....</b>	<b>206</b>
<b>Control Panel to VSD Communications .....</b>	<b>207</b>
<b>IGBT Gate Driver Boards .....</b>	<b>207</b>
<b>Current Transformers.....</b>	<b>208</b>
<b>DV/DT Output Suppression Network.....</b>	<b>208</b>
<b>Flash Tank Feed and Drain Valve Controller.....</b>	<b>208</b>
<b>DC Bus Voltage Isolation Board.....</b>	<b>209</b>
<b>Chiller Circuit Breaker.....</b>	<b>209</b>
<b>CHILLER CONFIGURATION JUMPERS .....</b>	<b>209</b>
<b>Number of Compressors Configuration Jumper .....</b>	<b>209</b>
<b>VSD LOGIC TO CHILLER MICROPROCESSOR BOARD RS-485 COMMUNICATION CONFIGURATION JUMPERS.....</b>	<b>210</b>
<b>MAXIMUM VSD FREQUENCY/MODEL DESIGNATOR.....</b>	<b>210</b>

## TABLE OF CONTENTS (CONT'D)

<b>SECTION 7 - OPERATION .....</b>	<b>211</b>
<b>OPERATING CONTROLS.....</b>	<b>211</b>
Anti-recycle Timer .....	211
Evaporator Pump Control.....	211
Evaporator Heater Control.....	211
Pumpdown Control .....	211
Compressor Heater Control .....	211
Alarms .....	211
Chiller Run Contact.....	211
Unit Switch .....	212
<b>BASIC OPERATING SEQUENCE.....</b>	<b>212</b>
Start Sequence and Loading.....	212
<b>NUMBER OF COMPRESSORS TO START .....</b>	<b>213</b>
General .....	213
Standard IPLV .....	213
Optional Optimized High IPLV.....	213
<b>MINIMUM VSD COMPRESSOR START/RUN FREQUENCY .....</b>	<b>214</b>
Minimum VSD Start Frequency .....	214
Minimum VSD Run Frequency .....	214
<b>ACCELERATION/DECELERATION RATE WHEN STARTING/STOPPING COMPRESSORS .....</b>	<b>215</b>
VSD Acceleration and Deceleration Rates .....	215
<b>STANDARD IPLV CAPACITY CONTROL.....</b>	<b>215</b>
Fuzzy Logic Control .....	216
Hot Water Starts.....	217
Lag Compressor Operation in Load Limiting .....	217
<b>OPTIONAL HIGH IPLV CAPACITY CONTROL .....</b>	<b>217</b>
Fuzzy Logic Control .....	219
Hot Water Starts.....	220
<b>LOAD LIMITING CONTROL .....</b>	<b>220</b>
Load Limiting .....	220
Motor Current Load Limiting/Unloading .....	220
Discharge Pressure Load Limiting/Unloading.....	220
Suction Pressure Load Limiting/Unloading.....	221
VSD Internal Ambient Temperature Load Limiting.....	221
VSD Baseplate Temperature Load Limiting .....	221
<b>FLASH TANK DRAIN AND FEED VALVE CONTROLLER .....</b>	<b>222</b>
Valve Controller and Control Algorithm Operation .....	222
MOP Setpoint Control for Hot Water Starts .....	223
Moderate To High Ambient MOP Setpoint Control.....	223
Low Ambient MOP Setpoint Control.....	223
Actual MOP Setpoint.....	223
Valve Controller LED's .....	224

## TABLE OF CONTENTS (CONT'D)

<b>ECONOMIZER CONTROL</b> .....	<b>225</b>
<b>CONDENSER FAN CONTROL</b> .....	<b>226</b>
Standard IPLV Fan Control .....	227
Optimized IPLV Fan Control .....	227
High VSD Cabinet Ambient Temperature Fan Operation.....	227
<b>VSD TEMPERATURE CONTROL, OPERATION OF THE COOLANT PUMP, AND VSD</b>	
<b>CABINET COOLING FANS</b> .....	<b>227</b>
<b>REMOTE TEMPERATURE RESET CONTROL</b> .....	<b>228</b>
Temperature Reset Control .....	228
Remote ISN Setpoint Control .....	228
Remote Temperature Reset .....	228
Local Current Limit Control.....	229
Pulldown Current Limit Setpoint.....	229
<b>REMOTE CURRENT LIMIT RESET CONTROL</b> .....	<b>229</b>
Remote ISN Current Limit Setpoint .....	230
Remote Current Limit Reset .....	230
<b>SOUND LIMIT CONTROL</b> .....	<b>231</b>
Sound Limiting and Local Sound Limit Setpoint .....	231
ISN Sound Limit Setpoint .....	231
Remote Sound Limit.....	231
<b>SECTION 8 - MICROPANEL</b> .....	<b>233</b>
<b>VSD OPERATION AND CONTROLS</b> .....	<b>233</b>
VSD Logic Board .....	233
VSD Start/run Initiation .....	233
PWM Generator Type and Carrier Frequency .....	233
Short Circuit Protection Minimum Output Pulse Width and Interlock Delay.....	233
Modulating Frequency .....	233
Maximum VSD Frequency .....	234
VSD % Modulation.....	234
VSD Cooling and Cooling Loop .....	234
IGBT Module Baseplate Temperature Sensing.....	235
VSD Internal Ambient Temperature Sensing .....	236
Pre-charge.....	236
Run Mode / Unit Restart.....	236
DC Bus Voltage Sensing and Scaling.....	237
Current Sensing and Scaling .....	237
VSD Transmitted Operating Parameters .....	237

## TABLE OF CONTENTS (CONT'D)

<b>VSD SAFETIES (FAULTS)</b> .....	<b>237</b>
Pre-charge Low DC Bus Voltage (Software) Fault.....	238
Pre-charge DC Bus Voltage Imbalance (Software) Fault .....	239
High DC Bus Voltage (Hardware) Fault .....	239
Low DC Bus Voltage (Software) Fault .....	239
DC Bus Voltage Imbalance (Software) Fault .....	239
High Motor Current (Hardware) Fault .....	240
Motor Current Overload (Software) Fault.....	240
Motor Current Overload (Hardware) Fault.....	240
IGBT Gate Driver (Hardware) Fault .....	240
High Baseplate Temperature (Software) Fault.....	241
High VSD Internal Ambient Temperature (Software) Fault .....	241
Single Phase Input (Hardware) Fault .....	241
Power Supply (Hardware) Fault .....	242
Run Relay (Software) Fault .....	242
VSD Logic Board Failure (Software) Fault .....	242
VSD CT Plug (Hardware) Fault .....	242
VSD Fault Data .....	242
Fault Relay/Fault Acknowledge Bit.....	243
VSD Fault Compressor Start Inhibit .....	243
<b>UNIT WARNINGS</b> .....	<b>243</b>
Unit Warning Operation .....	243
Low Battery Warning.....	243
Invalid Number of Compressors Warning.....	244
Invalid Serial Number Warning.....	244
Optimized Efficiency Disabled .....	244
<b>UNIT SAFETIES</b> .....	<b>245</b>
Unit Safety Operation.....	245
High Ambient Temp Fault .....	245
Low Ambient Temp Fault .....	245
Low Leaving Chilled Liquid Temp Fault.....	245
VSD Communications Failure Fault.....	246

## TABLE OF CONTENTS (CONT'D)

<b>SYSTEM SAFETIES (FAULTS)</b> .....	<b>246</b>
System Safety (Fault) Operation .....	246
High Discharge Pressure Cutout (Software) Fault .....	247
High Discharge Pressure Cutout (HPCO) (Hardware) Fault .....	247
Low Suction Pressure Cutout (Software) Fault .....	247
Low Motor Current Cutout Fault .....	247
High Differential Oil Pressure Cutout Fault .....	248
Low Differential Oil Pressure Cutout Fault .....	248
High Discharge Temperature Cutout Fault .....	248
High Oil Temperature Cutout Fault .....	248
Low Suction Superheat Cutout Fault .....	249
Low Discharge Superheat Cutout Fault .....	249
Sensor Failure Cutout Fault .....	249
High Motor Temperature Cutout Fault.....	250
High Flash Tank Level Cutout Fault.....	250
System Control Voltage Cutout Fault .....	250
<b>STATUS KEY</b> .....	<b>251</b>
Status Key Operation .....	251
General Status Messages .....	252
Unit Safety (Fault) Status Messages.....	253
System Safety (Fault) Status Messages.....	253
VSD Safety (Fault) Status Messages .....	253
Unit Warning Messages .....	253
<b>UNIT DATA KEY</b> .....	<b>254</b>
General .....	254
Unit Data Key Operation .....	254
<b>SYSTEM DATA KEYS 1 THROUGH 4</b> .....	<b>256</b>
General .....	256
System 1 Data Key Operation .....	256
System 2 through 4 Data Key Operation.....	257
Sensor Displays.....	258
<b>VSD DATA KEY</b> .....	<b>259</b>
General .....	259
VSD Data Key Operation.....	259
<b>OPERATING HOURS / START COUNTER KEY</b> .....	<b>261</b>

## TABLE OF CONTENTS (CONT'D)

<b>HISTORY KEY .....</b>	<b>262</b>
History Key Operation.....	262
Normal Shutdowns History .....	262
Fault Shutdowns History .....	263
Status Fault Type.....	263
Unit Fault Type.....	263
All Fault Data.....	263
Unit Data.....	264
VSD Data .....	264
System Data .....	265
Compressor Operating Hours and Starts .....	266
Chilled Liquid Setpoint Cooling Setpoints.....	267
Options .....	267
Remote Temperature Reset.....	267
Program Values .....	268
Pulldown Current Limit.....	268
<b>SETPOINTS KEY .....</b>	<b>269</b>
Setpoints Key Operation.....	269
<b>PROGRAM KEY.....</b>	<b>271</b>
Program Key Operation .....	271
Suction Pressure Cutout .....	271
Low Ambient Cutout.....	272
Low Leaving Liquid Temp Cutout .....	272
Motor Current Limit.....	272
Pulldown Current Limit.....	272
Pulldown Current Limit Time.....	272
Suction Superheat Setpoint .....	272
Unit ID Number .....	272
Sound Limit Setpoint .....	273
Default Values .....	273
<b>OPTIONS KEY.....</b>	<b>274</b>
Options Key Operation .....	274
Display Language Selection.....	274
Chilled Liquid Cooling Mode Selection .....	274
Local / Remote Control Mode Selection.....	275
Display Units Selection.....	275
System Lead/Lag Control Mode Selection.....	275
Remote Temperature Reset Selection .....	276
Remote Current Limit Input Selection .....	276
Remote Sound Limit Selection.....	276
Low Ambient Cutout Enable/Disable.....	276

## TABLE OF CONTENTS (CONT'D)

<b>DATE/TIME AND SCHEDULE KEYS</b> .....	<b>277</b>
Date/Time Key Operation.....	277
Schedule Key Operation.....	278
Unit Operating Schedule.....	279
Sound Limit Schedule.....	280
<b>MANUAL OVERRIDE KEY</b> .....	<b>281</b>
Manual Override Key Operation.....	281
<b>PRINT KEY</b> .....	<b>282</b>
Print Key Operation.....	282
Operating Data Printout.....	283
History Data Printout.....	284
<b>SERVICE KEY</b> .....	<b>285</b>
Service Key Operation.....	285
<b>SYSTEM SWITCHES KEY</b> .....	<b>291</b>
System Switches Key Operation.....	291
<b>SERIAL NUMBER PROGRAMMING</b> .....	<b>292</b>
<b>ENABLING OPTIMIZED HIGH IPLV MODE</b> .....	<b>293</b>
<b>UNIT SETUP MODE</b> .....	<b>294</b>
<b>DEFAULT PROGRAMMABLE VALUES</b> .....	<b>295</b>
<b>SERIAL PORT CONNECTIONS</b> .....	<b>295</b>
<b>ANALOG INPUT CONNECTIONS</b> .....	<b>296</b>
<b>DIGITAL INPUT CONNECTIONS</b> .....	<b>298</b>
<b>ANALOG OUTPUT CONNECTIONS</b> .....	<b>299</b>
<b>DIGITAL OUTPUT CONNECTIONS</b> .....	<b>300</b>
<b>BACNET, MODBUS AND YORKTALK 2 COMMUNICATIONS</b> .....	<b>302</b>
BACnet and Modbus Communications.....	305
Communications Data Map Notes.....	305
Yorktalk 2 Communications.....	309
<b>SECTION 9 - MAINTENANCE</b> .....	<b>313</b>
<b>R-134A CONVERSION TABLES</b> .....	<b>313</b>
<b>GENERAL REQUIREMENTS</b> .....	<b>314</b>
Daily Maintenance.....	314
Unit Status.....	314
Refrigerant Leaks.....	314
Operating Conditions.....	314
Compressor Oil Level.....	314
Refrigerant Charge.....	314
Scheduled Maintenance.....	314
Chiller / Compressor Operating Log.....	314
<b>MAINTENANCE REQUIREMENTS FOR YCIV CHILLERS</b> .....	<b>315</b>
<b>TROUBLESHOOTING GUIDE</b> .....	<b>316</b>
<b>EVACUATING A SYSTEM</b> .....	<b>318</b>

## TABLE OF CONTENTS (CONT'D)

LIMITED WARRANTY .....	319
Warranty on New Equipment.....	319
Warranty on Reconditioned or Replacement Materials .....	319
All Warranties and Guarantees Are Void If:.....	319
CHILLED LIQUID AND SUCTION TEMPERATURE SENSOR INPUT VOLTAGE .....	320
PRINTER WIRING .....	327
Printer Cables .....	328
Printer Setup .....	328
Okidata 184 .....	328
Weigh-tronix IMP 24 Model 2600 .....	328
Seiko .....	328
OPERATING LOG SHEET .....	329
Site and Chiller Information.....	329
Programmed Values .....	329
System Operating Conditions .....	331
Water System Conditions .....	332
RECOMMENDED SPARE PARTS .....	333

## LIST OF FIGURES

FIG. 1 - PWM CURRENT WAVEFORM .....	31
FIG. 2 - PWM VOLTAGE WAVEFORM.....	31
FIG. 3 - PIPEWORK ARRANGEMENT .....	48
FIG. 4 - VICTAULIC GROOVE.....	48
FIG. 5 - FLANGE ATTACHMENT .....	48
FIG. 6 - TWO COMPRESSOR WIRING DIAGRAM WITH CIRCUIT BREAKER.....	78
FIG. 7 - TWO COMPRESSOR WIRING DIAGRAM WITH TERMINAL BLOCK.....	78
FIG. 8 - THREE COMPRESSOR WIRING DIAGRAM WITH CIRCUIT BREAKER – SINGLE POINT.....	79
FIG. 9 - THREE COMPRESSOR WIRING DIAGRAM WITH TERMINAL BLOCK – SINGLE POINT.....	79
FIG. 10 - ELEMENTARY CONTROL WIRING DIAGRAM 2 COMPRESSOR MODELS .....	94
FIG. 11 - ELEMENTARY POWER WIRING DIAGRAM - YCIV0590-1000 2 COMPRESSOR MODELS.....	96
FIG. 12 - POWER WIRING CONNECTION DIAGRAM - YCIV0590-1000 2 COMPRESSOR MODELS.....	98
FIG. 13 - CONTROL WIRING CONNECTION DIAGRAM - YCIV0590-1000 2 COMPRESSOR MODELS ...	100
FIG. 14 - POWER ELEMENTARY WIRING DIAGRAM - YCIV0590-1000 2 COMPRESSOR MODELS.....	103
FIG. 15 - CONTROL ELEMENTARY DIAGRAM - YCIV1050-1500 3 COMPRESSOR MODELS .....	108
FIG. 16 - CONTROL ELEMENTARY DIAGRAM - YCIV1050-1500 3 COMPRESSOR MODELS .....	110
FIG. 17 - POWER ELEMENTARY DIAGRAM - YCIV1050-1500 3 COMPRESSOR MODELS .....	112
FIG. 18 - CONTROL WIRING CONNECTION DIAGRAM - YCIV1050-1500 3 COMPRESSOR MODELS....	114
FIG. 19 - POWER WIRING CONNECTION DIAGRAM - YCIV1050-1500 3 COMPRESSOR MODELS.....	118
FIG. 20 - POWER ELEMENETARY DIAGRAM - YCIV1050-1500 3 COMPRESSOR MODELS.....	122
FIG. 21 - REFRIGERANT FLOW DIAGRAM.....	175
FIG. 22 - PROCESS AND INSTRUMENTATION DIAGRAM.....	176
FIG. 23 - COMPONENT LOCATIONS .....	177
FIG. 24 - CONTROL AND VSD CABINET COMPONENTS.....	178
FIG. 25 - CHILLER CONTROL BOARD, RELAY BOARDS, MICROGATEWAY, AND OPTIONAL CIRCUIT BREAKER.....	179
FIG. 26 - CHILLER CONTROL BOARD, RELAY BOARDS, AND MICROGATEWAY, 2 COMPRESSOR ....	180
FIG. 27 - CHILLER CONTROL BOARD, RELAY BOARDS, AND MICROGATEWAY, 3 COMPRESSOR ....	181
FIG. 28 - VSD LOGIC BOARD .....	182
FIG. 29 - VSD LOGIC BOARD (ORIGINAL - OBSOLETE), P/N 031-02477-000 .....	183
FIG. 30 - VSD LOGIC BOARD (NEW), P/N 031-02507-XXX .....	184
FIG. 31 - POWER COMPONENTS, 2 COMPRESSOR.....	185
FIG. 32 - POWER COMPONENTS, 3 COMPRESSOR.....	186
FIG. 33 - FAN CONTACTORS AND 3T TRANSFORMER, 2 COMPRESSOR .....	187
FIG. 34 - FAN CONTACTORS, 3 COMPRESSOR .....	188
FIG. 35 - VSD COMPONENTS .....	189
FIG. 36 - VSD COMPONENTS, 2 COMPRESSOR .....	190
FIG. 37 - VSD COMPONENTS, 3 COMPRESSOR .....	191
FIG. 38 - VSD COMPONENTS, 2 COMPRESSOR .....	192
FIG. 39 - VSD COMPONENTS, 3 COMPRESSOR .....	193
FIG. 40 - INVERTER POWER COMPONENTS, 2 COMPRESSOR.....	194
FIG. 41 - INVERTER POWER COMPONENTS, 3 COMPRESSOR.....	195
FIG. 42 - INVERTER POWER COMPONENTS.....	196
FIG. 43 - GLYCOL PUMP & FILL TUBE LOCATIONS.....	198

## LIST OF FIGURES (CONT'D)

FIG. 44 - GLYCOL PIPING AND FILL TUBE LOCATION .....	199
FIG. 45 - COMPRESSOR COMPONENTS.....	200
FIG. 46 - NEW BOARD P/N 031-02507-000 .....	206
FIG. 47 - OBSOLETE BOARD P/N 031-02477-000 .....	206
FIG. 48 - CHILLER CONTROL (COOLING) RANGE.....	213
FIG. 49 - NUMBER OF COMPRESSORS TO START .....	214
FIG. 50 - MINIMUM VSD START FREQUENCY .....	214
FIG. 51 - MINIMUM VSD RUN FREQUENCY .....	215
FIG. 52 - FLASH TANK DRAIN AND FEED VALVE CONTROLLER .....	222
FIG. 53 - LED LOCATIONS .....	224
FIG. 54 - POWER AND COMMS LED'S .....	224
FIG. 55 - POWER, COMMS AND SYSTEM OPEN/CLOSE LED'S .....	224
FIG. 56 - CONDENSER FAN LOCATIONS .....	226
FIG. 57 - STANDARD IPLV FAN CONTROL.....	227
FIG. 58 - HIGH IPLV FAN CONTROL.....	227
FIG. 59 - CONTROL BOARD CONNECTIONS.....	303
FIG. 60 - PRINT CABLE - CHILLER TO SERIAL PRINTER .....	327

## LIST OF TABLES

TABLE 1 - COMPRESSORS AND THE APPROPRIATE JUMPER POSITIONS .....	209
TABLE 2 - VSD LOGIC BOARD ADDRESS JUMPER .....	210
TABLE 3 - MAXIMUM FREQUENCY / MODEL DESIGNATOR JUMPER .....	210
TABLE 4 - FUZZY LOGIC LOADING/UNLOADING VS. ERROR .....	217
TABLE 5 - FUZZY LOGIC LOADING/UNLOADING VS. ERROR .....	219
TABLE 6 - CURRENT LIMIT LOAD LIMITING/UNLOADING .....	220
TABLE 7 - DISCHARGE PRESSURE LOAD LIMITING/UNLOADING .....	221
TABLE 8 - SUCTION PRESSURE LOAD LIMITING/UNLOADING .....	221
TABLE 9 - VSD INTERNAL AMBIENT LOAD LIMITING/UNLOADING .....	221
TABLE 10 - VSD BASEPLATE TEMPERATURE LOAD LIMITING/UNLOADING .....	222
TABLE 11 - FAN STAGES AND CORRESPONDING OUTPUTS .....	226
TABLE 12 - VSD OPERATING DISPLAY PARAMETERS .....	237
TABLE 13 - LOW DIFFERENTIAL OIL PRESSURE CUTOUT .....	248
TABLE 14 - START INHIBIT SENSOR THRESHOLDS .....	250
TABLE 15 - SENSOR MIN/MAX OUTPUTS .....	258
TABLE 16 - SETPOINT LIMITS .....	270
TABLE 17 - PROGRAMMABLE OPERATING PARAMETERS .....	273
TABLE 18 - PRINTOUT TYPES .....	282
TABLE 19 - UNIT SETUP PROGRAMMABLE VALUES .....	294
TABLE 20 - SERIAL PORT CONNECTIONS .....	296
TABLE 21 - ANALOG INPUT CONNECTIONS .....	296
TABLE 22 - DIGITAL INPUT CONNECTIONS .....	298
TABLE 23 - ANALOG OUTPUT CONNECTIONS .....	299
TABLE 24 - DIGITAL OUTPUT CONNECTIONS .....	300
TABLE 25 - MINIMUM, MAXIMUM AND DEFAULT VALUES .....	303
TABLE 26 - VALUES REQUIRED FOR BAS COMMUNICATION .....	304
TABLE 27 - REAL TIME ERROR NUMBERS .....	304
TABLE 28 - BACNET AND MODBUS COMMUNICATIONS DATA MAP .....	306
TABLE 29 - YORKTALK 2 COMMUNICATIONS DATA MAP .....	310
TABLE 30 - R-134A PRESSURE TO SATURATED TEMPERATURE CONVERSION .....	313
TABLE 31 - TEMPERATURE INPUT VOLTAGE SENSOR (MEASURED SIGNAL TO SHIELD AT THE SENSOR) .....	320
TABLE 32 - OUTSIDE AIR TEMPERATURE SENSOR INPUT VOLTAGE (MEASURED SIGNAL TO SHIELD AT THE SENSOR) .....	321
TABLE 33 - PRESSURE TRANSDUCER OUTPUT VOLTAGE (MEASURED SIGNAL TO RETURN AT THE TRANSDUCER) .....	322
TABLE 34 - MOTOR TEMPERATURE SENSOR RESISTANCE (CHECK AT THE MOTOR) .....	323
TABLE 35 - COMPRESSOR MOTOR OVERLOAD SETTINGS AND MAX. VSD FREQUENCY .....	324

**THIS PAGE INTENTIONALLY LEFT BLANK**

## SECTION 1 - GENERAL CHILLER INFORMATION AND SAFETY

### INTRODUCTION

YORK YCIV0590-1500 chillers are manufactured to the highest design and construction standards to ensure high performance, reliability and adaptability to all types of air conditioning installations.

The unit is intended for cooling water or glycol solutions and is not suitable for purposes other than those specified in this manual.

This manual contains all the information required for correct installation and commissioning of the unit, together with operating and maintenance instructions. The manuals should be read thoroughly before attempting to operate or service the unit.

All procedures detailed in the manuals, including installation, commissioning and maintenance tasks must only be performed by suitably trained and qualified personnel.

The manufacturer will not be liable for any injury or damage caused by incorrect installation, commissioning, operation or maintenance resulting from a failure to follow the procedures and instructions detailed in the manuals.

### WARRANTY

Johnson Controls warrants all equipment and materials against defects in workmanship and materials for a period of eighteen months from date of shipment, unless labor or extended warranty has been purchased as part of the contract.

The warranty is limited to parts only replacement and shipping of any faulty part, or sub-assembly, which has failed due to poor quality or manufacturing errors. All claims must be supported by evidence that the failure has occurred within the warranty period, and that the unit has been operated within the designed parameters specified.

All warranty claims must specify the unit model, serial number, order number and run hours/starts. Model and serial number information is printed on the unit identification plate.

The unit warranty will be void if any modification to the unit is carried out without prior written approval from Johnson Controls.

For warranty purposes, the following conditions must be satisfied:

- The initial start of the unit must be carried out by trained personnel from an authorized Johnson Controls Service Center. See “*Commissioning*” (Page 53).
- Only genuine YORK approved spare parts, oils, coolants, and refrigerants must be used. Recommendations on spare part stocking can be found on Page 333.
- All the scheduled maintenance operations detailed in this manual must be performed at the specified times by suitably trained and qualified personnel. See “*Maintenance*” section, Pages 313-333.
- Failure to satisfy any of these conditions will automatically void the warranty. See “*Warranty Policy*” (Page 319).

### SAFETY

#### Standards for Safety

YCIV chillers are designed and built within an ISO 9002 accredited design and manufacturing organization.

The chillers comply with the applicable sections of the following Standards and Codes:

- ANSI/ASHRAE Standard 15, Safety Code for Mechanical Refrigeration.
- ANSI/NFPA Standard 70, National Electrical Code (N.E.C.).
- ASME Boiler and Pressure Vessel Code, Section VIII Division 1.
- ARI Standard 550/590-98, Water Chilling Packages Using the Vapor Compression Cycle.
- ASHRAE 90.1 Energy Standard for Building Except Low-Rise Residential Buildings.
- ARI 370 Sound Rating of Large Outdoor Refrigeration and Air Conditioning Equipment.

In addition, the chillers conform to Underwriters Laboratories (U.L.) for construction of chillers and provide U.L./cU.L. Listing Label.

#### Responsibility for Safety

Every care has been taken in the design and manufacture of the unit to ensure compliance with the safety

requirements listed above. However, the individual operating or working on any machinery is primarily responsible for:

- Personal safety, safety of other personnel, and the machinery.
- Correct utilization of the machinery in accordance with the procedures detailed in the manuals.

## ABOUT THIS MANUAL

The following terms are used in this document to alert the reader to areas of potential hazard.



A **WARNING** is given in this document to identify a hazard, which could lead to personal injury. Usually an instruction will be given, together with a brief explanation and the possible result of ignoring the instruction.



A **CAUTION** identifies a hazard which could lead to damage to the machine, damage to other equipment and/or environmental pollution. Usually an instruction will be given, together with a brief explanation and the possible result of ignoring the instruction.

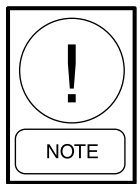

A **NOTE** is used to highlight additional information, which may be helpful to you but where there are no special safety implications.

The contents of this manual include suggested best working practices and procedures. These are issued for guidance only, and they do not take precedence over the above stated individual responsibility and/or local safety regulations.

This manual and any other document supplied with the unit are the property of Johnson Controls which reserves all rights. They may not be reproduced, in whole or in part, without prior written authorization from an authorized Johnson Controls representative.

## MISUSE OF EQUIPMENT

### Suitability for Application

The unit is intended for cooling water or glycol solutions and is not suitable for purposes other than those specified in these instructions. Any use of the equipment other than its intended use, or operation of the equipment contrary to the relevant procedures may result in injury to the operator, or damage to the equipment.

The unit must not be operated outside the design parameters specified in this manual.

### Structural Support

Structural support of the unit must be provided as indicated in these instructions. Failure to provide proper support may result in injury to the operator, or damage to the equipment and/or building.

### Mechanical Strength

The unit is not designed to withstand loads or stresses from adjacent equipment, pipework or structures. Additional components must not be mounted on the unit. Any such extraneous loads may cause structural failure and may result in injury to the operator, or damage to the equipment.

### General Access

There are a number of areas and features, which may be a hazard and potentially cause injury when working on the unit unless suitable safety precautions are taken. It is important to ensure access to the unit is restricted to suitably qualified persons who are familiar with the potential hazards and precautions necessary for safe operation and maintenance of equipment containing high temperatures, pressures and voltages.

### Pressure Systems

The unit contains refrigerant vapor and liquid under pressure, release of which can be a danger and cause injury. The user should ensure that care is taken during installation, operation and maintenance to avoid damage to the pressure system. No attempt should be made to gain access to the component parts of the pressure system other than by suitably trained and qualified personnel.

## Electrical

The unit must be grounded. No installation or maintenance work should be attempted on the electrical equipment without first switching power OFF, isolating and locking-off the power supply. Servicing and maintenance on live equipment must not be attempted. No attempt should be made to gain access to the control panel or electrical enclosures during normal operation of the unit.

## Rotating Parts

Fan guards must be fitted at all times and not removed unless the power supply has been isolated. If ductwork is to be fitted, requiring the wire fan guards to be removed, alternative safety measures must be taken to protect against the risk of injury from rotating fans.

## Sharp Edges

The fins on the air-cooled condenser coils have sharp metal edges. Reasonable care should be taken when working in contact with the coils to avoid the risk of minor abrasions and lacerations. The use of gloves is recommended.

Frame rails, brakes, and other components may also have sharp edges. Reasonable care should be taken when working in contact with any components to avoid risk of minor abrasions and lacerations.

## Refrigerants and Oils

Refrigerants and oils used in the unit are generally non-toxic, non-flammable and non-corrosive, and pose no special safety hazards. Use of gloves and safety glasses is, however, recommended when working on the unit. The buildup of refrigerant vapor, from a leak for example, does pose a risk of asphyxiation in confined or enclosed spaces and attention should be given to good ventilation.

## High Temperature and Pressure Cleaning

High temperature and pressure cleaning methods (e.g. steam cleaning) should not be used on any part of the pressure system as this may cause operation of the pressure relief device(s). Detergents and solvents, which may cause corrosion, should also be avoided.

## Emergency Shutdown

In case of emergency, the control panel is fitted with a UNIT switch to stop the unit in an emergency. When operated, it removes the low voltage 120VAC electrical supply from the inverter system, thus shutting down the unit.

**THIS PAGE INTENTIONALLY LEFT BLANK**

## SECTION 2 - PRODUCT DESCRIPTION



2

### INTRODUCTION

YORK YCIV R134a chillers are designed for water or glycol cooling. All units are designed to be located outside on the roof of a building or at ground level.

The units are completely assembled with all interconnecting refrigerant piping and internal wiring, ready for field installation.

Prior to delivery, the unit is pressure tested, evacuated, and fully charged with refrigerant and oil in each of the two independent refrigerant circuits. After assembly, an operational test is performed with water flowing through the cooler to ensure that each refrigerant circuit operates correctly.

The unit structure is manufactured from heavy gauge, galvanized steel. Many external structural parts are coated with “Champagne” baked-on enamel powder paint. This provides a finish which, when subjected to ASTM B117, 1000 hour, 5% salt spray conditions, shows breakdown of less than 1/8" either side of a scribed line (equivalent to ASTM D1654 rating of “6”).

All exposed power wiring is routed through liquid-tight, non-metallic conduit.

### General System Description

The Latitude (YCIV) Air-Cooled Chiller line combines the best of modern screw compressor design with the latest technology in variable speed drives. The result is superior control and efficiency in real world conditions. The VSD enables slowing the speed of the compressor to match the load on the system resulting in precise chilled liquid control, minimized sound, maximum energy efficiency, and reduced cost of ownership. The VSD also provides soft starts with no electrical inrush. The lack of heat build-up on start also enables required off time between starts to be reduced to a period of 2 minutes.

The YCIV Air-Cooled Screw Chiller utilizes many components, which are the same or nearly the same as a standard screw chiller of a similar size. This includes modular frame rails, condenser, fans, compressors and evaporator.

The chiller consists of 2 or 3 screw compressors in a corresponding number of separate refrigerant circuits, a single shell and tube DX evaporator, an air-cooled condenser, flash tanks, drain/feed valves, oil separators, and compressor mufflers. Oil separators utilize no moving parts and are rated for a 405 PSIG design working pressure. Oil cooling is accomplished by routing oil from the oil separator through several rows of tubes in the air cooled condenser.

An integral liquid cooled, transistorized, PWM, Variable Speed Drive (VSD) is controlled by the chiller microprocessor control panel to start/stop, select compressors to run, and select compressor speed. Power Factor is 95% at part or full load.

The chiller microprocessor communicates with the VSD Logic Board via a 3-wire RS-485 opto coupled data link. The VSD Logic Board runs the number of compressors required to meet the load and the compressors to the speed requested by the chiller microprocessor.

The basic system control architecture is shown in the diagram below:

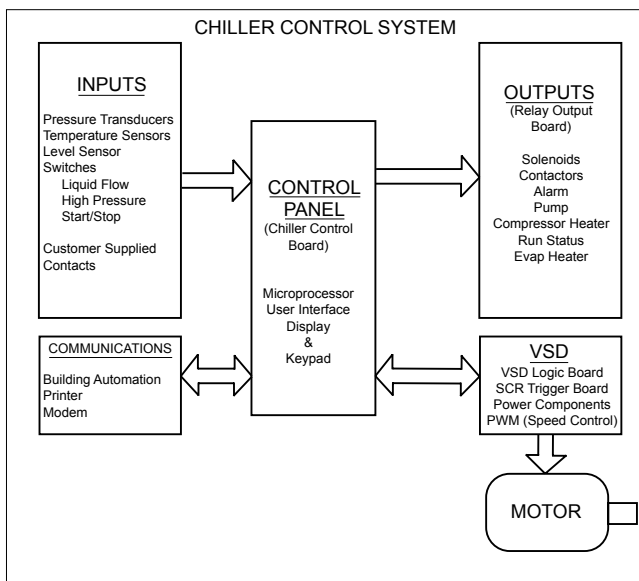

LD10478

The chiller is designed to operate in ambient temperatures of 0°F to 125°F (-18°C to 52°C). Capacity control is capable of reducing chiller capacity to 10% of full load without the need for Hot Gas Bypass.

**Compressor**

The direct drive semi-hermetic rotary twin-screw MTS compressor is designed for industrial refrigeration applications and ensures high operational efficiencies and reliable performance. Capacity control is achieved by stepless VSD speed changes. No slide valve is required. Smooth capacity control is achieved between 10% and 100% of chiller capacity in most operating conditions. The compressor is a positive displacement type characterized by two helically grooved rotors, which are manufactured from forged steel. The 4 pole motor operates at speeds up to 6000 RPM to direct drive the male rotor, which in turn drives the female rotor on a light film of oil.

Refrigerant gas is injected into the void created by the un-meshing of the five lobed male and seven lobed female rotors. Further meshing of the rotors closes the rotor threads to the suction port and progressively compresses the gas in an axial direction to the discharge port. The gas is compressed in volume and increased in pressure before exiting at a designed volume at the discharge end of the rotor casing. Since the intake and discharge cycles overlap, a resulting smooth flow of gas is maintained.

The rotors are housed in a cast iron compressor housing precision machined to provide optimal clearances for the rotors. Contact between the male and female rotor is primarily rolling on a contact band on each of the rotor's pitch circle. This results in virtually no rotor wear and increased reliability, a trademark of the screw compressor.

The MTS compressor incorporates a complete anti-friction bearing design for reduced power input and increased reliability. Separated, cylindrical, roller bearings handle radial loads. Angular-contact ball bearings handle axial loads. Together they maintain accurate rotor positioning at all pressure ratios, thereby minimizing leakage and maintaining efficiency.



LD10481



LD10482

Motor cooling is provided by suction gas from the evaporator flowing across the motor. Redundant overload protection is provided using both internal thermistor and current overload protection on all three phases.

The MTS compressor is lubricated by removing oil from the refrigerant using an external oil separator. The pressurized oil is then cooled in the condenser coils and piped back to the compressor through a removable 0.005" mesh screen oil filter to provide compressor lubrication. The cast iron compressor housing design working pressure is 450 PSIG (31 bar). Each chiller receives a 300 PSIG (21 bar) low side and a 450 PSIG (31 bar) high side factory test. A 350 Watt (115-1-60 Hz) cartridge heater is located in the compressor. The heater is temperature activated to prevent refrigerant condensation.

The following items are also included:

- Acoustically tuned, external discharge muffler to minimize noise, while optimizing flow for maximum performance.
- Discharge shutoff valve.
- Rain-tight terminal box.
- Suction gas screen within the compressor housing.

### Evaporator

The system uses a high-efficiency shell and tube type Direct Expansion Evaporator. Each of the two or three refrigerant circuits consists of two (2) passes with the chilled liquid circulating back and forth across the tubes from one end to the other.

The design working pressure of the cooler on the shell side is 150 PSIG (10 bar), and 235 PSIG (16 bar) for the tube (refrigerant) side. The evaporator is constructed and tested in accordance with applicable sections of the ASME Pressure Vessel Code, Section VII, Division (1). Waterside exempt per paragraph U-1, c, (6).

The water baffles are fabricated from galvanized steel to resist corrosion. Removable heads are provided for access to internally enhanced, seamless, copper tubes. Water vent and drain connections are included.

The cooler is equipped with a thermostatically controlled heater for protection to -20°F (-29°C) ambient and insulated with 3/4" (19 mm) flexible closed-cell insulation.

The water nozzles are provided with grooves for mechanical couplings and should be insulated by the contractor after pipe installation.

A 300 PSIG (20.7 bar) waterside design working pressure option is available.

Two compressor chillers utilize a typical 2-pass "E" type evaporator with liquid inlets and suction outlets at the same end. Entering chilled liquid enters the refrigerant liquid inlet end of the cooler and leaving chilled liquid exits at the opposite end.

Three compressor chillers utilize a single pass "J" type evaporator with liquid inlets at one end and suction outlets at the opposite end. Entering chilled liquid is split and half flow enters at each end of the evaporator with leaving chilled liquid exiting in the center of the evaporator. "J" type evaporators have fewer, longer tubes than a comparable "E" type. This results in a smaller diameter, longer shell. Water flow rate internally in the evaporator is ½ of the total loop flow rate since the flow is split between two inlets. This results in a low evaporator water pressure drop.

### Condenser

The fin and tube condenser coils are manufactured from seamless, internally enhanced, high-condensing coefficient, corrosion-resistant copper tubes arranged in staggered rows and mechanically expanded into corrosion resistant aluminum alloy fins with full height fin collars. The condenser has a design working pressure of 450 PSIG (31 bar).

Multiple, standard low sound, high efficiency, TEAO motor driven fans move air through the coils. They are dynamically and statically balanced, direct drive with corrosion-resistant glass fiber reinforced composite blades molded into low-noise, full airfoil cross sections, providing vertical air discharge from extended orifices for efficiency and low sound. Fans or pairs of fans are located in a separate compartments separated by "V" panels to prevent cross flow during fan cycling. Guards of heavy-gauge, PVC-coated galvanized steel are provided.

The standard fan motors are high-efficiency, direct drive, 6-pole, 3-phase, Class- "F," current overload protected, totally enclosed (TEAO) type with double-sealed, permanently lubricated ball bearings.

## Flash Tank Feed Valve/Drain Valves

A flash tank is fitted to both refrigerant circuits. The flash tank is a shell type refrigerant reservoir designed to sustain 2 phase refrigerant. The purpose of the flash tank is to increase the efficiency of the system. A portion of the liquid fed into the flash tank gases off, cooling the remaining liquid in the tank another 25-35°F. Both liquid and gas exist in the flash tank. The refrigerant gas in the flash tank is fed to the economizer port on the compressor at a point on the rotors approximately 1.7 x suction when the economizer solenoid is activated. The liquid in the tank is fed to the evaporator.

The vapor feed to the economizer port of the compressor is at an intermediate pressure between discharge and suction (1.7 x suction) and therefore little energy is required to pump it back through the compressor to condenser pressure. This results in a very small loss to system efficiency.

The design working pressure of the flash tank is 450 PSIG (31 bar). The Drain and Feed Valves on the flash tank are activated on start-up. The Feed Valve on the flash tank acts like a liquid line solenoid, but also functions to control the liquid level in the flash tank. The Drain Valve functions similar to an electronic expansion valve (EEV). The Drain Valve controls refrigerant flow to the evaporator based on suction superheat. Both valves are stepper motor valves. An economizer solenoid is placed between the flash tank and the economizer port of the compressor. The economizer solenoid valve is generally activated at speeds above 90 to 120 Hz, depending upon a number of other factors.

Both valves are controlled by 2 phase drive signals from a stand-alone controller in the Control. Signals from sensors such as suction pressure and temperature are sent to the Chiller Control Board, which in turn sends control signals to the Drain and Feed Valve Controller. The control algorithm in the Chiller Control Board will attempt to control the liquid level in the flash tank to 35% on the level sensor and the system will fault if the flash tank level exceeds 87.5%.

During operation, it will be noted the flash tank level will typically remain between 30-40% level when the economizer solenoid is ON. The economizer solenoid valve will typically be on most of the time. When the economizer solenoid is OFF, the liquid level will vary greatly as the Drain and Feed Valves directly affect the level as they open and close.

## Oil Separator/Oil System

The external oil separators, with no moving parts and designed for minimum oil carry-over, are mounted in the discharge line of the compressor. The high pressure discharge gas is forced around a 90 degree bend. Oil is forced to the outside of the separator through centrifugal action and captured on wire mesh where it drains to the bottom of the oil separator and is then forced into the condenser.

The oil (YORK “L” oil – a POE oil used for all refrigerant applications), flows from the oil separator, through the condenser where it is cooled, and back into the compressor through a replaceable 0.5 micron oil filter at high pressure. This high pressure “oil injection” forces the oil into the compressor, where it is fed to the bearings and rotors for lubrication. After lubricating the bearings, it is injected through orifices on a closed thread near the suction end of the rotors. The oil is automatically injected because of the pressure difference between the discharge pressure and the reduced pressure at the suction end of the rotors. This lubricates the rotors as well as provides an oil seal against leakage around the rotors to ensure refrigerant compression efficiency.

The oil also provides cooling by transferring much of the heat of compression from the gas to the oil, keeping discharge temperatures down and reducing the chance for oil breakdown. Oil injected into the rotor cage flows into the rotors at a point about 1.2 x suction. This ensures that a required minimum differential of at least 30 PSID exists between discharge and 1.2 x suction, to force oil into the rotor case. A minimum of 10 PSID (0.6 bar) is all that is required to ensure protection of the compressor. The oil pressure safety is monitored as the difference between suction pressure and the pressure of the oil entering the rotor case.

Maximum working pressure of the oil separator is 450 PSIG (31 bar). Oil level should be above the midpoint of the “lower” oil sight glass when the compressor is running. Oil level should not be above the top of the “upper” sight glass.

## Relief Valves

Two relief valves are installed in each refrigerant circuit. A 325 PSIG relief valve is located on each flash tank and a 250 PSIG relief valve is located on the suction line of the compressor near the evaporator.

## Oil Cooling

Oil cooling is provided by routing oil from the oil separator through several of the top rows of the condenser coils and back to the compressor.

## Capacity Control

When cooling is needed, one or more compressors, as determined by the system microprocessor based on deviation from setpoint, will start at minimum speed with low inrush current. Variable speed operation of the compressor reduces the capacity and allows smooth balancing of the compressor capacity with the cooling load.

Capacity control is accomplished by varying the number of compressors and the speed of the compressors with the VSD to promote stable, smooth, and precise loading/unloading.

Hot Gas Bypass is not required with VSD control of the compressors.

The chiller is available with Standard IPLV or High IPLV software (EPROM). High IPLV software optimizes the performance of the chiller capacity and fan controls. High IPLV chillers also require additional factory programming.

## Power and Control Panel

All controls and the VSD are factory-wired and function tested. The panel enclosures are designed to NEMA 3R (IP65) rating and are manufactured from powder-painted steel with hinged, latched, and gasket sealed outer doors with wind struts for safer servicing.

The power and micro control panels are combined into a single control/power cabinet and include:

- Compressor VSD Controls.
- Chiller Microprocessor Controls.
- Fan Controls.
- All Other Chiller Controls.

The Display and keypad are accessible through an access door without opening the main doors to the electrical cabinet.

## Each Power Compartment Contains

Incoming single point power is standard utilizing either a lockable circuit breaker or terminal block, 115VAC control transformer, VSD, fan contactors, ON/OFF unit switch, microcomputer keypad and display, Chiller Control and VSD Logic Boards, and relay boards.

Current transformers sense each phase of motor current, and send corresponding signals to the Chiller Logic Board. Current monitoring protects the compressor motors from damage due to low motor current, high motor current, short circuit current, single phasing, and compressor overload.

Short Circuit Withstand Rating of the chiller electrical enclosure is 30,000 Amps for standard terminal block connection. Ratings are in accordance with UL508C. A Circuit Breaker Option can be added to increase the Short Circuit Withstand Rating to 200/230V equals 100,000 Amps, 380/460 V equals 65,000 Amps, and 575V equals 42,000 Amps.

## Microprocessor and VSD Controls

Microprocessors on the Chiller Control Board and VSD Logic Board control starting, stopping, loading, unloading, safeties, and chilled liquid temperature control. Chilled liquid control decisions are a function of temperature deviation from setpoint and the rate of change of temperature.

The standard controls include:

- Brine Chilling.
- Thermal Storage.
- Run Signal Contacts.
- Unit Alarm Contacts.
- Chilled Liquid Pump Control.
- Automatic reset after power failure.
- Automatic system optimization to match operating conditions.

Remote cycling, optional current limiting, optional temperature setpoint reset, and optional remote sound limit can be accomplished by connecting user-supplied signals to the microprocessor.

Unit operating software is stored in non-volatile memory. Field programmed setpoints are retained in lithium battery backed real time clock (RTC) memory for 10 years.

## Display

The display consists of a liquid crystal 2 line by 40 characters per line display, with backlighting for outdoor viewing of operating parameters and program points.

Parameters are displayed in 5 languages in either English (°F and PSIG) or Metric (°C and Bars) units, and for each circuit, the following items can be displayed:

- Entering and leaving chilled liquid, and ambient temperature.
- Day, date and time. Daily start/stop times. Holiday and Manual Override status.
- Compressor operating hours and starts. Automatic or manual lead/lag. Lead compressor identification.
- Run permissive status. Compressor run status.
- Anti-recycle timers.
- System suction (and suction superheat), discharge (and discharge superheat), and oil pressures and temperatures.
- Percent full load compressor motor current and average motor current. Compressor motor speed (frequency).
- Cutout status and setpoints for supply chilled liquid temperature, low suction pressure, high discharge pressure and temperature, high oil temperature, low ambient, and low leaving liquid temperature.
- Unloading limit setpoints for high discharge pressure and compressor motor current.
- Status of evaporator heater, condenser fans, load/unload timers, and chilled water pump.
- “Out of range” message.
- Up to 10 fault shutdown histories.

**Keypad**

An operator keypad allows complete control of the system from a central location. The keypad utilizes an overlay to allow use in 5 languages. The keypad is a color-coded, 36 button, sealed keypad with keys for Display, Entry, Setpoints, Clock, Print, Program, Unit ON/OFF and other functions. Details on a few of the keys follow:

**Status** – Allows viewing present unit or system status displayed by the microprocessor.

**Entry** – Numeric keypad and supporting keys used to confirm Setpoint changes, cancel inputs, advance day, and change AM/PM.

**Setpoints** – For setting chilled liquid temperature, chilled liquid range, remote reset temperature range.

**Date/Time** – Used to set time, daily or holiday start/stop schedule, manual override for servicing, and sound limiting schedule.

**Print** – Used to display or print operating data or system fault shutdown history for last ten faults. Printouts are generated through an RS-232 port via a separate printer.

**Program** – For setting low leaving liquid temperature cutout, average motor current limit, and pulldown demand limit.

Displays are also provided for programming low ambient cutout, low suction pressure cutout, superheat setpoint, etc., under the PROGRAM key.

**Unit Switch**

A master UNIT switch allows activation or de-activation of the chiller system. Separate system switches for controlling each system are provided as part of the chiller control panel keypad.

## Variable Speed Drive (VSD)

The VSD (variable speed drive) is a liquid cooled, transistorized, PWM inverter, which provides speed control to vary the speed of 2, 3 or 4 compressor motors. The VSD changes the duration of the voltage pulses supplied to the motor to enable control of compressor speed to match the system load. A PWM generator, on the VSD Logic Board, with a switching frequency of 3125 Hz modulates the voltage signal to provide a relatively pulses constant V/F ratio. In some cases, the V/F ratio is slightly modified to provide additional torque to the motor. Sample 3 phase current waveforms are shown in FIG. 1 to show the sinusoidal characteristics of the current drawn by the compressor motors.

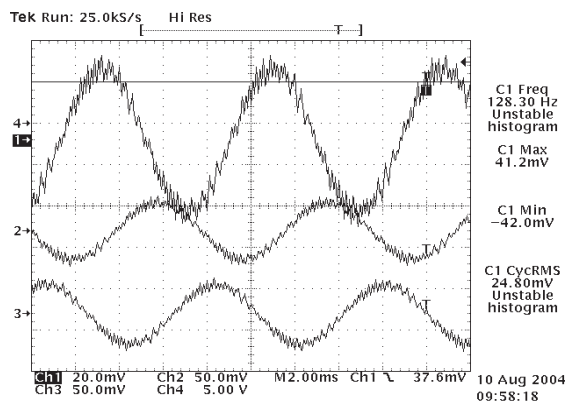

LD10479

**FIG. 1 - PWM CURRENT WAVEFORM**

A Sample PWM voltage waveforms is shown in FIG. 2. The pulses near the sides of the rectangular groups of waves are notably narrower, representing the lower voltage of a sinusoidal waveform as it rises or falls from the “0” crossing.

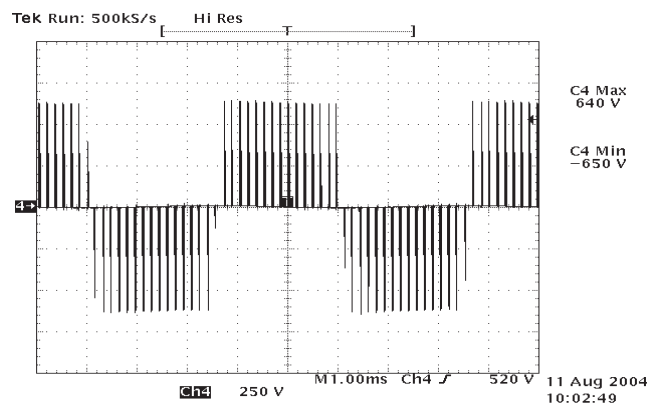

LD10480

**FIG. 2 - PWM VOLTAGE WAVEFORM**

The power section of the drive is composed of four major blocks consisting of an AC to DC rectifier section with accompanying pre-charge circuit, a DC link filter section, a three phase DC to AC inverter section, and an output suppression network.

The AC to DC rectifier utilizes a semi-converter formed by the connection of three SCR/diode modules (1SCR through 3SCR) in a three phase bridge configuration. The modules are mounted on a liquid cooled heatsink. Use of the semi-converter configuration permits implementation of a separate pre-charge circuit to limit the flow of current into the DC link filter capacitors when the drive is switched on and it also provides a fast disconnect from the power mains when the drive is switched off. When the drive is turned off, the SCR's in the semi-converter remain in a non-conducting mode and the DC link filter capacitors remain uncharged. When the drive is commanded to run, the DC link filter capacitors are slowly charged via the semi-converter. The SCR's are then gated fully on.

Three power fuses (1FU - 3FU), an optional circuit breaker (1SW) and a standard 5% impedance minimum 3-phase line reactor connect the AC to DC converter to the incoming power. Very fast semiconductor power fuses are utilized to ensure that the SCR/diode module packages do not rupture if a catastrophic failure were to occur on the DC link. The SCR Trigger Board provides the gating pulses for the SCR's as commanded by the VSD Logic Board.

The DC Link filter section of the drive consists of a group of electrolytic filter capacitors (C1-C6). This capacitor bank effectively smoothes the ripple voltage from the AC to DC rectifier while simultaneously providing a large energy reservoir for use by the DC to AC inverter section of the drive. In order to achieve the required voltage capability for the capacitor portion of the filter, filter capacitor “banks” are formed by connecting two groups of parallel capacitors in series to form a capacitor “bank”. In order to assure an equal sharing of the voltage between the series connected capacitors and to provide a discharge means for the capacitor bank when the VSD is powered off, “bleeder” resistors (1RES and 2RES) are connected across the capacitor banks.

The DC to AC inverter section of the VSD serves to convert the rectified and filtered DC back to AC at the magnitude and frequency commanded by the VSD Logic Board. The inverter section is actually composed of two to four identical inverter output phase assemblies. These assemblies are in turn composed of 3 pairs of Insulated Gate Bipolar Transistor (IGBT) modules mounted to a liquid cooled heatsink, and a IGBT Gate Driver Board, which provides the ON and OFF gating pulses to the IGBT's as determined by the VSD Logic Board. In order to minimize the parasitic inductance between the IGBT's and the capacitor banks, copper plates, which electrically connect the capacitors to one another and to the IGBT's are connected together using a "laminated bus" structure.

This "laminated bus" structure is actually composed of a pair of copper bus plates with a thin sheet of insulating material acting as the separator/insulator. The "laminated bus" structure forms a parasitic capacitor, which acts as a small valued capacitor, effectively canceling the parasitic inductance of the bus bars themselves. To further cancel the parasitic inductances, a series of small film capacitors are connected between the positive and negative plates of the DC link.

The VSD output suppression network is composed of a series of capacitors and resistors connected in a three phase delta configuration. The parameters of the suppression network components are chosen to work in unison with the parasitic inductance of the DC to AC inverter sections in order to simultaneously limit both the rate of change of voltage and the peak voltage applied to the motor windings. By limiting the peak voltage to the motor windings, as well as the rate-of-change of motor voltage, we can avoid problems commonly associated with PWM motor drives, such as stator-winding end-turn failures and electrical fluting of motor bearings.

The VSD is cooled by a propylene glycol cooling loop. The loop utilizes a glycol pump, which pumps glycol through the VSD heatsinks to cool the power components. The glycol is then circulated through the condenser to reject the heat from the VSD. The cooled glycol is then circulated back through the loop.

Various ancillary sensors and boards are used to send information back to the VSD Logic Board. Each IGBT Power Module within the DC to AC inverter section contains a thermistor heatsink temperature sensor to provide temperature information to the VSD Logic Board. The Bus Isolator board utilizes three resistors

on the board to provide a "safe" impedance (resistance) between the DC link filter capacitors located on the output phase bank assemblies and the VSD Logic Board. It provides the means to sense the positive, midpoint and negative connection points of the VSD's DC link without applying high voltage to the VSD Logic Board. A Current transformer is included on each output phase assembly to provide motor current information to the VSD Logic Board.

## ACCESSORIES AND OPTIONS

### Sound Reduction Options

The standard chiller has fans that operate at normal speed, no compressor enclosure, and is typically used in non-sensitive sound areas such as industrial areas or locations with loud traffic background noise. One or more of the following sound reduction options may be employed by the system designer as normally generated machine noise is considered in the overall project design.

#### ***Ultra Quiet Fans***

With this option, the basic chiller is equipped with specially designed fans and motors to provide lower sound levels and retain appropriate airflow. The result is reduced fan generated noise with minimal effect on the chiller capacity or efficiency at standard AHRI conditions. **(Factory-mounted)**

#### ***Two-Speed Fans***

With this option, the basic chiller is equipped with fans designed with two operating speeds. At high ambient conditions the fans operate at the normal speed with sound levels equivalent to Ultra Quiet Fans. As the ambient temperature falls, the fans automatically reduce to slow speed reducing sound levels. If very low sound is required at all ambient conditions normal fan speed can be inhibited. **(Factory-mounted)**

#### ***Reduced Sound Option***

With this option the chiller is equipped with an unlined compressor enclosure. This option is typically used for daytime operation where background noise is lower than normal city traffic etc. **(Factory-mounted)**

#### ***Low Sound Option***

This option is only available with the selection of Ultra Quiet Fans or Two-Speed Fans. The chiller is equipped with an acoustically lined compressor enclosure. This option is typically for locations near residential areas, hotels, or hospitals etc., where background noise is limited. When paired with the Two-Speed Fan option

the unit can operate at normal speed during the day, when background noise levels are noticeable, and at low speed in the evening and at night when background levels are lower. **(Factory-mounted)**

### **SilentNight™**

Standard variable speed compressors result in a chiller system that has lower part load sound values than conventional air-cooled chillers. Over 99% of chiller operating hours occur when building loads are less than design and/or ambient temperatures are less than design. As a result, all YCIV model chillers will operate with less than full load sound output nearly all the time. This is especially important on evenings and weekends when neighbors are home the most. Due to time of day based sound regulations it may be desirable to force the chiller to a lower sound level on demand. The SilentNight™ control option provides a control input to limit sound output of the chiller based on time of day. This feature is programmable at the chiller panel or can be controlled remotely via signal (4 to 20mA or 0 to 10 VDC) from a BAS system.

### **High Static Fans - (400V/50Hz and 380V/60Hz)**

Condenser fans with higher power motors suitable for high external static pressure, up to 100Pa (0.4 in. water), across condenser coils. Select this option if additional air-flow resistance may be present due to flow restrictions such as field installed ducts, filters, sound-enclosures etc. **(Factory-mounted)**

### **High Airflow Fans - (400V/50Hz and 380V/60Hz)**

Condenser fans with airfoil type blades and high power motors providing extra airflow across coils. In some chiller configurations, this option can provide an increase in chiller capacity. Contact your local Johnson Controls representative for more information. **(Factory-mounted)**

### **Condenser Coil Protection**

Standard condenser coil construction materials include aluminum fins, copper tubes, and galvanized tube supports for generally good corrosion resistance. However, these materials are not adequate for all environments. The system designer can take steps to inhibit coil corrosion in harsh applications and enhance equipment life by choosing from these options based on project design parameters and related environmental factors. **(Factory-mounted)**

### **Pre-Coated Fin Condenser Coils**

The air-cooled condenser coils are constructed of epoxy-coated aluminum fins. This can provide corrosion resistance comparable to copper-fin coils in typical seashore locations. Either these or the post coated coils (below), are recommended for units being installed at the seashore or where salt spray may hit the unit.

### **Post-Coated Epoxy Dipped Condenser Coils**

The unit is built with dipped-cured epoxy condenser coils. This is another choice for seashore and other corrosive applications (with the exception of strong alkalis, oxidizers and wet bromine, chlorine and fluorine in concentrations greater than 100 ppm).

### **Copper Fin Condenser Coils**

The unit constructed with copper tube condenser coils, which have copper fins. (This is not recommended for units in areas where they may be exposed to acid rain.)

### **Protective Chiller Panels**

#### **Wire Panels (Full Unit)**

UV stabilized black polyvinyl chloride coated, heavy gauge, welded wire mesh guards mounted on the exterior of the unit. Protects condenser coil faces and prevents unauthorized access to refrigerant components (compressors, pipes, cooler, etc.), yet provides free air flow. This can cut installation cost by eliminating the need for separate, expensive fencing. **(Factory-mounted)**

#### **Louvered Panels (Condenser Coils Only)**

Louvered panels, painted the same color as the unit, are mounted over the exterior condenser coil faces on the sides of the unit to visually screen and protect coils. **(Factory-mounted)**

#### **Louvered Panels (Full Unit)**

Louvered panels, painted the same color as the unit, enclose the unit to protect condenser coils from incidental damage, visually screen internal components, and prevent unauthorized access to internal components. **(Factory-mounted)**

#### **Louvered (Condensers)/Wire Panels (Mechanical)**

Louvered panels, painted the same color as the unit, are mounted on external condenser coil faces. Heavy gauge, welded wire-mesh, coated to resist corrosion, around base of machine to restrict unauthorized access. **(Factory-mounted)**

**Evaporator Options**

**Double Thick 1-1/2" Insulation**

Double thickness insulation is provided. **(Factory-mounted)**

**Raised Face Flange Accessory**

Used for cooler nozzles:

- 150 psig (10.3 barg), welded flanges (field kit, matching pipe flange by contractor).
- 150 psig (10.3 barg) companion weld flanges (field kit - not available with 460V units).
- 150 psig (10.3 barg), ANSI/AWWA C-606 couplings (field kit, matching pipe flange by contractor).

**Opposite Handed Evaporator Water Connections**

Easily installed standard water connections are on the left-hand side of the unit, when viewed from the control panel end.

**General Options**

**Flow Switch Accessory**

Vapor proof SPDT, NEMA 3R switch, 150 psig (10.3 barg) DWP, 20°F to 250°F (-7°C to 121°C) with 1" NPT (IPS) connection for upright mounting in horizontal pipe (This flow switch or equivalent must be furnished with each unit). **(Field-mounted)**.

**Differential Pressure Switch**

Alternative to the paddle-type flow switch. Range is 3 to 45 psig (0.2 to 3 barg) with 1/4" NPTE pressure connections. **(Field-mounted)**

**Building Automation System Interface**

Chiller will accept 4 to 20mA or 0 to 10 VDC input to reset the leaving chilled liquid temperature. **(Factory-mounted)**

**Multi-Unit Sequence Control**

Separate sequencing control center provided to permitting control of up to eight chillers in parallel based on mixed liquid temperature (interconnecting wiring by others). **(Field-mounted)**

**Service Isolation Valve**

Service suction isolation valve added to unit for each refrigerant circuit. **(Factory-mounted)**

**Chicago Code Relief Valve**

Special relief valves per Chicago code. **(Factory-mounted)**

**Pressure Relief (CE/PED) Service Valve Kit**

Each relief valve is mounted on a sealable ball valve to aid maintenance. **(Factory-mounted)**

**Circuit Breaker**

Power panel will come equipped with a factory mounted circuit breaker at the point of incoming single or multi-point connections that provides the following:

- A means to disconnect power mounted on chiller.
- Circuit breaker(s) sized to provide the motor branch circuit protection, short circuit protection and ground fault protection for the motor branch-circuit conductors, the motor control apparatus and the motors. (Chiller mounted circuit breaker option sized for branch circuit protection eliminates the need to provide a separate 'line of sight' disconnect and separate branch circuit protection device.)
- A lockable operating handle that extends through power panel door. This allows power to be disconnected without opening any panel doors.
- A Short Circuit Withstand Rating of 65,000 amps when the chiller electrical enclosure when using circuit breaker option is 380, 400, and 460V. Rated IAW UL508.

**Vibration Isolation**

**Elastomeric Isolation**

This option is recommended for normal installations. It provides very good performance in most applications for the least cost. **(Field-mounted)**

**One Inch Spring Isolators**

Spring and cage type isolators for mounting under the unit base rails. They are level adjustable. Nominal deflection is 1" and may vary slightly by application. **(Field-mounted)**

**Two Inch Seismic Spring Isolators**

Restrained Spring-Flex Mounting isolators incorporate a rugged welded steel housing with vertical and horizontal limit stops. Housings designed to withstand a minimum 1.0g accelerated force in all directions up to 2" (51mm). The deflection may vary slightly by application. They are level adjustable. **(Field-mounted)**

## UNIT MODEL NUMBER NOMENCLATURE

The model number denotes the following characteristics of the unit.

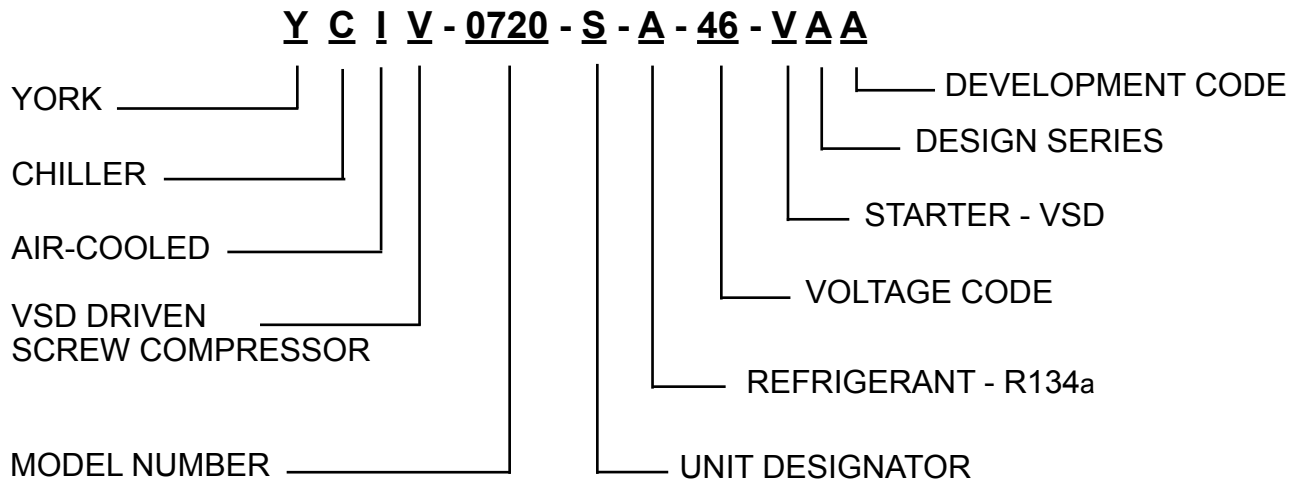

### UNIT DESIGNATOR

E- High Efficiency with Standard IPLV  
S- Standard Efficiency with Standard IPLV  
P- Standard Efficiency with Optimized IPLV  
V- High Efficiency with Optimized IPLV

### VOLTAGE CODE

17=200-3-60  
28=230-3-60  
40=380-3-60  
46=460-3-60  
50=380/400/415-3-50  
58=575-3-60

**COMPLETE PIN NUMBER DESCRIPTION**

FEATURE	DESCRIPTION	OPTION	DESCRIPTION
<b>CONTRACT</b>	Contract Number	NUM	Contract Number = {num}
<b>ORDER</b>	Order Quantity	QTY	Order quantity = {ord_qty}
<b>USA</b>	USA Origin	N	USA origin not required
		Y	USA origin required
<b>SHIP WT</b>	Shipping Weight	LBS	Crane/Rigging Shipping Weight = {lbs}
		KG	Crane/Rigging Shipping Weight = {kg}
<b>MODEL</b>	Model (PIN 1-4)	YCIV	YCIV
<b>CAP</b>	Nominal Capacity (PIN 5-8)	0590	0590
		0630	0630
		0700	0700
		0760	0760
		0800	0800
		0830	830
		0930	0930
		1050	1050
		1120	1120
		1180	1180
		1340	1340
		1500	1500
<b>UNIT</b>	Unit Designator (PIN 9)	S	Standard Efficiency, Standard IPLV
		P	Standard Efficiency, Optimized IPLV
		E	High Efficiency/High Ambient Unit, Standard IPLV
		V	High Efficiency/High Ambient Unit, Optimized IPLV
<b>REF.</b>	Refrigerant (PIN 10)	A	R-134a
<b>VOLTS</b>	Voltage (PIN 11, 12)	17	200/3/60
		28	230/3/60
		40	380/3/60
		46	460/3/60
		50	380-415/3/50
		58	575/3/60
<b>STARTER</b>	Starter (PIN 13)	V	Variable Speed Drive
<b>DESIGN</b>	Design Series (PIN 14)	A	Design Series A
<b>DEV</b>	Modification Level (PIN 15)	A	Mod Level B
<b>POWER</b>	Power Fld (PIN 16, 17)	SX	SP Supply TB
		BX	SP Circuit Breaker w/Lockable Handle
		SS	SP Supply TB w/Ind. Sys. Disconnect Switches
		CS	SP Circuit Breaker w/Ind. Sys. Disconnect Switches
		QQ	Special Power Option
<b>TRANS</b>	Control Transformer (PIN 18)	T	Control Transformer required
		Q	Special Transformer or Power Strip required
<b>PFC</b>	Convenience Outlet (PIN 19)	X	No Option Required
		O	Convenience Outlet, 115V GFI (Customer Powered)
		Q	Special quote
<b>AMB</b>	PIN 20	X	No option required
		Q	Special quote

**COMPLETE PIN NUMBER DESCRIPTION (CONT'D)**

FEATURE	DESCRIPTION	OPTION	DESCRIPTION
<b>BAS</b>	BAS Interface (PIN 21)	X	No BAS Reset/Offset required
		T	BAS/EMS Temp Reset/Offset
		C	BAS/EMS Current Reset/Offset
		B	BAS/EMS Both Temp and Current Reset/Offset
		M	ISN Microgateway
		Q	Special BAS Reset/Offset required
<b>LCD</b>	LCD (PIN 22)	X	English LCD & Keypad Display (std)
		S	Spanish LCD & Keypad Display
		F	French LCD & Keypad Display
		G	German LCD & Keypad Display
		I	Italian LCD & Keypad Display
		P	Portuguese LCD & Keypad Display
		Q	Special LCD & Keypad Display
<b>RDOUT</b>	Silent Night (PIN 23)	X	No option required
		N	Silent Night sound limiting control option
		Q	Special quote
<b>SAFETY</b>	Safety Code (PIN 24)	L	N. American Safety Code (cUL/cETL)
		C	CE listing
		Q	Special Safety Code
<b>SENSOR</b>	PIN 25	X	No option required
		Q	Special quote
<b>PUMP</b>	Pump Control (PIN 26)	X	No Pump Control required
		Q	Special Pump Control required
<b>REMOTE</b>	Remote Ctrl Panel (PIN 27)	X	No Remote Control Panel required
		O	OptiView Remote Control Panel required
		Q	Special Remote Control Panel required
<b>SEQ</b>	Sequence Kit (PIN 28)	X	No Sequence Kit required
		S	Sequence Control & Automatic Lead Transfer = {seq}
		Q	Special Sequence Kit required
<b>TEMP</b>	Water Temp (PIN 29, 30)	NUM	Leaving Water Temp. = {temp} degrees
		QQ	Special LWT requirements
<b>CHICAGO</b>	Chicago Code Kit (PIN 31)	X	No Chicago Code Kit required
		C	Chicago Code Kit required
		S	Service Isolation Valve
		B	Both Isolation Valve and Chicago Code
		P	Pressure Relief Service Valve Kit
		D	Service Isolation & Pressure Relief Valve Kit
		R	Dual Pressure Relief
		G	Dual Pressure Relief & Suction Service Isolation
		Q	Special Chicago Code Kit required
<b>VALVES</b>	Valves (PIN 32)	X	Standard Valves required
		Q	Special Optional Valves required
<b>HGBP</b>	PIN 33	X	No option required
		Q	Special quote
<b>GAUGE</b>	PIN 34	X	No option required
		Q	Special quote
<b>OVERLOAD</b>	PIN 35	X	No option required
		Q	Special quote
<b>PIN36</b>	PIN 36	X	No option required
		Q	Special quote

**COMPLETE PIN NUMBER DESCRIPTION (CONT'D)**

FEATURE	DESCRIPTION	OPTION	DESCRIPTION
HTR	Crankcase Heater (PIN 37)	H	Compressor Crankcase Heaters
		Q	Special quote
DWP	DWP (PIN 38)	X	150 PSIG DWP
		3	300 PSIG DWP
		Q	Special DWP
INS	Insulation (PIN 39)	X	3/4" Cooler Insulation
		D	1-1/2" Cooler Insulation
		Q	Special Cooler Insulation
FLANGES	Flanges (PIN 40)	X	No Flanges required
		W	Weld Flange Kit required
		V	Victaulic Flange Kit required
		M	Weld Flange with Mating Flange
		F	Victaulic Flange with Welded Mating Flange
		Q	Special Flanges required
FLOW	Flow Switch (PIN 41)	X	No Flow Switch required
		S	One Flow Switch required
		T	Two Flow Switches required
		U	Three Flow Switches required
		D	One Differential Pressure Switch required
		E	Two Differential Pressure Switches required
		F	Three Differential Pressure Switches required
		Q	Special Switch required
VESSEL	Vessel Codes (PIN 42)	A	ASME Pressure Vessel Codes
		E	PED Pressure Vessel Code
		Q	Special Pressure Vessel Codes
CLR	Cooler (PIN 43)	X	Standard Cooler
		R	Remote Cooler
		Q	Special Cooler requirements
PIN44	Connections (PIN 44)	L	Handed cooler left, view from control panel end
		R	Handed cooler right, view from control panel end
		Q	Special quote
COILS	Coils (PIN 45)	A	Aluminum Coils
		C	Copper Fin Coils
		B	Pre-Coated Fin Coils
		P	Post-Coated Dipped Coils
		E	Pre-coated Epoxy Non-slit ripple fins
		Q	Special Coils
HEAT	Heat Recovery (PIN 46)	X	Partial Heat Recovery not required
		H	Partial Heat Recovery required
		D	Desuperheater
		Q	Special quote
FANMOTORS	Fan Motors (PIN 47)	X	TEAO Fan Motors
		Q	Special Fan Motors
PANEL	Enclosure Panels (PIN 48)	X	No Enclosure Panels required
		1	Wire (Full Unit) Encl Panels (factory)
		2	Wire (Full Unit) Encl Panels (field)
		3	Wire/Louvered Encl Panels (factory)
		4	Wire/Louvered Encl Panels (field)
		5	Louvered (cond only) Encl Panels (factory)
		6	Louvered (cond only) Encl Panels (field)
		7	Louvered (full unit) Encl Panels (factory)
		8	Louvered (full unit) Encl Panels (field)
Q	Special Enclosure Panels required		

**COMPLETE PIN NUMBER DESCRIPTION (CONT'D)**

FEATURE	DESCRIPTION	OPTION	DESCRIPTION
<b>ACOUSTIC</b>	Acoustical arrgt (PIN 49)	X	No Sound Enclosure required
		R	Reduced Noise
		N	Low Noise
		Q	Special Sound Enclosure required
<b>PIN 50</b>	PIN 50	X	No option required
		Q	Special quote
<b>PIN 51</b>	PIN 51	X	No option required
		Q	Special quote
<b>FANS</b>	Fans (PIN 52)	X	Standard Low Sound Fans
		L	Ultra Quiet Fans
		H	High Static Fans
		Q	Special Sound Fans
<b>PAINT</b>	Overspray Paint (PIN 53)	X	No Final Overspray Paint required
		Q	Special Final Overspray Paint required
<b>ISOL</b>	Isolators (PIN 54)	X	No Vibration Isolators required
		1	1" Deflection Isolators required
		S	Seismic Isolators required
		N	Neoprene Pad Isolators required
		Q	Special Vibration Isolators required
<b>WARRANTY</b>	Warranty (PIN 55)		For Marketing Purposes
<b>REFRIGERANT WTY</b>	Refrigerant Wty (PIN 56)		For Marketing Purposes
<b>SHIP</b>	Ship Instructions (PIN 57)	X	No option required
		A	Buy American Act Compliance
		C	Container Shipping Kit
		B	Both Buy American Act Compliance and Container Shipping Kit
		P	Container Shipment Ready, Loading to be Arranged by CSR
		Q	Special quote
<b>PIN58</b>	PIN 58		For Marketing Purposes
<b>PIN59</b>	PIN 59	X	No option required
		Q	Special quote
<b>PIN60</b>	PIN 60	X	No option required
		Q	Special quote
<b>MFG</b>	Plant of Mfg (PIN 61)	R	Plant of Manufacture - Monterrey
<b>LOC</b>	Mfg Location	MEX	Monterrey
		SAT	San Antonio
<b>YW</b>	YorkWorks Version	CV	YorkWorks configuration version {cv}
		UV	YorkWorks upload version {uv}
<b>SQ</b>	Special Quote	Q	Special quote

**THIS PAGE INTENTIONALLY LEFT BLANK**

## SECTION 3 - HANDLING AND STORAGE

### DELIVERY AND STORAGE

To ensure consistent quality and maximum reliability, all units are tested and inspected before leaving the factory. Units are shipped completely assembled and containing refrigerant under pressure. Units are shipped without export crating unless crating has been specified on the Sales Order.

If the unit is to be put into storage, prior to installation, the following precautions should be observed:

- The chiller must be “blocked” so that the base is not permitted to sag or bow.
- Ensure that all openings, such as water connections, are securely capped.
- Do not store where exposed to ambient air temperatures exceeding 110°F (43°C).
- The condensers should be covered to protect the fins from potential damage and corrosion, particularly where building work is in progress.
- The unit should be stored in a location where there is minimal activity in order to limit the risk of accidental physical damage.
- To prevent inadvertent operation of the pressure relief devices the unit must not be steam cleaned.
- It is recommended that the unit is periodically inspected during storage.

### INSPECTION

Remove any transit packing and inspect the unit to ensure that all components have been delivered and that no damage has occurred during transit. If any damage is evident, it should be noted on the carrier’s freight bill and a claim entered in accordance with the instructions given on the advice note.

Major damage must be reported immediately to your local Johnson Controls representative.

### MOVING THE CHILLER

Prior to moving the unit, ensure that the installation site is suitable for installing the unit and is easily capable of supporting the weight of the unit and all associated services.

The units are designed to be lifted using cables. A spreader bar or frame should be used in order to prevent damage to the unit from the lifting chains (*see Pages 42 and 43*).

Units are provided with lifting eyes in the sides of the base frame, which can be attached to directly using shackles or safety hooks (*see Pages 42 and 43*).



***The unit must only be lifted by the base frame at the points provided. Never move the unit on rollers, or lift the unit using a forklift truck.***

Care should be taken to avoid damaging the condenser cooling fins when moving the unit.

### Lifting Weights

*For details of weights and weight distribution, refer to the data shipped in the chiller information packet and unit nameplate.*

UNIT RIGGING

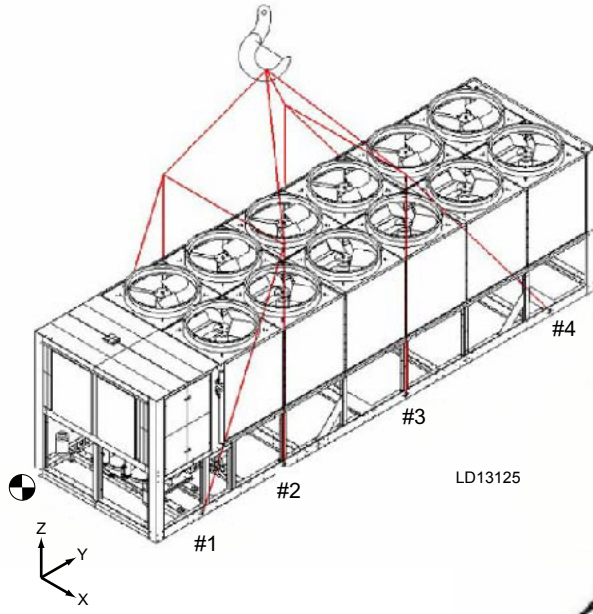

2 COMPRESSOR

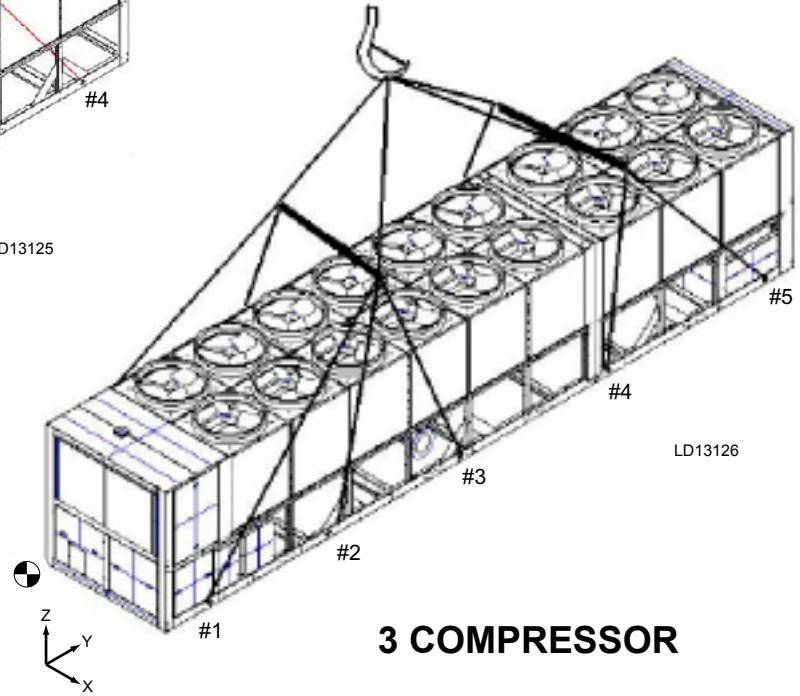

3 COMPRESSOR

LIFT POINTS DIMENSIONS TAKEN FROM (NOT ALL POINTS ON UNITS)

2 COMPRESSOR MODELS

50 HZ	EFFICIENCY	#1		#2		#3		#4		#5	
		INCH	METRIC	INCH	METRIC	INCH	METRIC	INCH	METRIC	INCH	METRIC
0590	HIGH	Y = 33.3	Y = 846	Y = 136.7	Y = 3473	Y = 216.7	Y = 5505	---	---	---	---
0600	STD	Y = 33.3	Y = 846	Y = 136.7	Y = 3473	Y = 216.7	Y = 5505	---	---	---	---
0630	HIGH	Y = 33.3	Y = 846	Y = 136.7	Y = 3473	Y = 224.7	Y = 5708	---	---	---	---
0650	STD	Y = 33.3	Y = 846	Y = 136.7	Y = 3473	Y = 216.7	Y = 5505	---	---	---	---
0700	HIGH	Y = 33.3	Y = 846	Y = 136.7	Y = 3473	Y = 224.7	Y = 5708	---	---	---	---
0720	STD	Y = 33.3	Y = 846	Y = 136.7	Y = 3473	Y = 224.7	Y = 5708	---	---	---	---
0760	HIGH	Y = 33.3	Y = 846	Y = 136.7	Y = 3473	Y = 224.7	Y = 5708	---	---	---	---
0770	STD	Y = 33.3	Y = 846	Y = 136.7	Y = 3473	Y = 224.7	Y = 5708	---	---	---	---
0800	HIGH	Y = 33.3	Y = 846	Y = 92.7	Y = 2355	Y = 180.7	Y = 4590	Y = 284.9	Y = 7235	---	---
0830	HIGH	Y = 33.3	Y = 846	Y = 92.7	Y = 2355	Y = 180.7	Y = 4590	Y = 284.9	Y = 7235	---	---
0840	STD	Y = 33.3	Y = 846	Y = 136.7	Y = 3473	Y = 224.7	Y = 5708	---	---	---	---
0920	STD	Y = 33.3	Y = 846	Y = 92.7	Y = 2355	Y = 180.7	Y = 4590	Y = 284.9	Y = 7235	---	---
0930	HIGH	Y = 33.3	Y = 846	Y = 92.7	Y = 2355	Y = 180.7	Y = 4590	Y = 284.9	Y = 7235	---	---
1000	STD	Y = 33.3	Y = 846	Y = 92.7	Y = 2355	Y = 180.7	Y = 4590	Y = 284.9	Y = 7235	---	---

3 COMPRESSOR MODELS

50 HZ	EFFICIENCY	#1		#2		#3		#4		#5	
		INCH	METRIC	INCH	METRIC	INCH	METRIC	INCH	METRIC	INCH	METRIC
1050	HIGH	Y = 33.2	Y = 843.8	Y = 141.1	Y = 3584.8	Y = 238.6	Y = 6061.3	Y = 357	Y = 9067.4	---	---
1070	STD	Y = 33.2	Y = 843.8	Y = 141.1	Y = 3584.8	Y = 238.6	Y = 6061.3	Y = 357	Y = 9067.4	---	---
1120	HIGH	Y = 33.2	Y = 843.8	Y = 123.7	Y = 3142.2	Y = 216.7	Y = 5504.2	Y = 320.5	Y = 8139.9	Y = 401	Y = 10185
1180	STD	Y = 33.2	Y = 843.8	Y = 141.8	Y = 3584.8	Y = 238.6	Y = 6061.3	Y = 357	Y = 9067.4	---	---
1220	HIGH	Y = 33.2	Y = 843.8	Y = 120.7	Y = 3064.9	Y = 216.7	Y = 5504.2	Y = 320.5	Y = 8139.9	Y = 401	Y = 10185
1340	STD	Y = 33.2	Y = 843.8	Y = 120.7	Y = 3064.9	Y = 216.7	Y = 5504.2	Y = 320.5	Y = 8139.9	Y = 401	Y = 10185
1380	HIGH	Y = 33.2	Y = 843.8	Y = 120.7	Y = 3064.9	Y = 217.8	Y = 5531.5	Y = 328.1	Y = 8334.6	Y = 445	Y = 11302.6
1500	STD	Y = 33.2	Y = 843.8	Y = 120.7	Y = 3064.9	Y = 217.8	Y = 5531.5	Y = 328.1	Y = 8334.6	Y = 445	Y = 11302.6



LD10483

Lifting hooks should be inserted into the holes provided in the bottom of the frame rail.

Use spreader bars to avoid lifting chains hitting the chiller. Various methods of spreader bar arrangements may be used; keeping in mind the intent is to keep the unit stable and to keep the chains from hitting the chiller and causing damage.

3



LD10484

Use spreader bars to avoid lifting chains hitting the chiller.



***Never lift the chiller using a forklift or by hooking to the top rails. Use only the lifting holes provided.***

Lifting Instructions are placed on a label on the chiller and on the shipping bag.

**THIS PAGE INTENTIONALLY LEFT BLANK**

## SECTION 4 - INSTALLATION

### LOCATION REQUIREMENTS

To achieve optimum performance and trouble-free service, it is essential that the proposed installation site meets the location and space requirements for the model being installed. *For dimensions, refer to Section 6 “Technical Data” in this IOM.*

It is important to ensure that the minimum service access space is maintained for cleaning and maintenance purposes.

### OUTDOOR INSTALLATIONS

The units can be installed at ground level on a suitable flat level foundation easily capable of supporting the weight of the unit, or on a suitable rooftop location. In both cases an adequate supply of air is required. Avoid locations where the sound output and air discharge from the unit may be objectionable.

The location should be selected for minimum sun exposure and away from boiler flues and other sources of airborne chemicals that could attack the condenser coils and steel parts of the unit.

If located in an area accessible to unauthorized persons, steps must be taken to prevent access to the unit by means of a protective fence. This will help to prevent the possibility of vandalism, accidental damage, or possible harm caused by unauthorized removal of protective guards or opening panels to expose rotating or high voltage components.

For ground level locations, the unit must be installed on a suitable flat and level concrete base that extends to fully support the two side channels of the unit base frame. A one-piece concrete slab, with footings extending below the frost line is recommended. To avoid noise and vibration transmission, the unit should not be secured to the building foundation.

On rooftop locations, choose a place with adequate structural strength to safely support the entire operating weight of the unit and service personnel. The unit can be mounted on a concrete slab, similar to ground floor locations, or on steel channels of suitable strength. The channels should be spaced with the same centers as the unit side and front base rails. This will allow vibration isolators to be fitted if required. Isolators are recommended for rooftop locations.

Any ductwork or attenuators fitted to the unit must not have a total static pressure resistance, at full unit airflow, exceeding the capability of the fans installed in the unit.

### INDOOR INSTALLATIONS

The unit can be installed in an enclosed plant room, provided the floor is level and of suitable strength to support the full operating weight of the unit. It is essential that there is adequate clearance for airflow to the unit. The discharge air from the top of the unit must be ducted away to prevent re-circulation of air within the plant room. If common ducts are used for fans, non-return dampers must be fitted to the outlet from each fan.

The discharge ducting must be properly sized with a total static pressure loss, together with any intake static pressure loss, less than the available static pressure capability for the type of fan fitted.

The discharge air duct usually rejects outside the building through a louver. The outlet must be positioned to prevent the air being drawn directly back into the air intake for the condenser coils; as such re-circulation will affect unit performance.

### LOCATION CLEARANCES

Adequate clearances around the unit(s) are required for the unrestricted airflow for the air-cooled condenser coils and to prevent re-circulation of warm discharge air back onto the coils. If clearances given are not maintained, airflow restriction or re-circulation will cause a loss of unit performance, an increase in power consumption, and may cause the unit to malfunction. Consideration should also be given to the possibility of down drafts, caused by adjacent buildings, which may cause re-circulation or uneven unit airflow.

For locations where significant cross winds are expected, such as exposed roof tops, an enclosure of solid or louver type is recommended to prevent wind turbulence interfering with the unit airflow.

When units are installed in an enclosure, the enclosure height should not exceed the height of the unit on more than one side. If the enclosure is of louvered construction, the same requirement of static pressure loss applies as for ducts and attenuators stated above.

Where accumulation of snow is likely, additional height must be provided under the unit to ensure normal airflow to the unit



***Clearance dimensions provided elsewhere are necessary to maintain good airflow and ensure correct unit operation. It is also necessary to consider access requirements for safe operation and maintenance of the unit and power and control panels. Local health and safety regulations, or practical considerations for service replacement of large components, may require larger clearances than those given in the “Technical Data” section (Page 146).***

## VIBRATION ISOLATORS

Optional sets of vibration isolators can be supplied loose with each unit.

Using the Isolator tables shipped with the unit in the information pack, refer to the “Dimension” section (pages 126 through 145), “Isolator Selection and Mounting” section (pages 147 through 162) and “Isolator Types” (pages 164 through 169 for units shipped on or after June 15, 2008 and Pages 170 through 174 for units shipped before June 15, 2008). Identify each mount and its correct location on the unit.

### Installation

Place each mount in its correct position and lower the unit carefully onto the mounts ensuring the mount engages in the mounting holes in the unit base frame.

On adjustable mounts, transfer the unit weight evenly to the springs by turning the mount adjusting nuts (located just below the top plate of the mount) counter-clockwise to raise and clockwise to lower. This should be done two turns at a time until the top plates of all mounts are between 1/4" and 1/2" (6 and 12 mm) clear of top of their housing and the unit base is level.

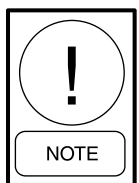

***A more detailed installation instruction is provided on Pages 164 through 169 for units shipped on or after June 15, 2008 and Pages 170 through 174 for units shipped before June 15, 2008.***

## SHIPPING BRACES

The chiller’s modular design does not require shipping braces.

## CHILLED LIQUID PIPING

### General Requirements

The following piping recommendations are intended to ensure satisfactory operation of the unit(s). Failure to follow these recommendations could cause damage to the unit, or loss of performance, and may invalidate the warranty.

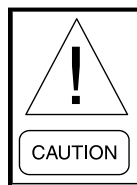

***The maximum flow rate and pressure drop for the cooler must not be exceeded at any time. Refer to the “Technical Data” section for details.***

***The liquid must enter the cooler at the inlet connection. The inlet connection for the cooler is at the control panel end of the cooler.***

**A flow switch must be installed in the customer piping at the outlet of the cooler and wired back to the control panel using shielded cable.**

There should be a straight run of piping of at least 5 pipe diameters on either side. The flow switch should be wired to Terminals 2 and 13 on the 1TB terminal block (See FIG. 31 and 32, Pages 185 and 186). A flow switch is required to prevent damage to the cooler caused by the unit operating without adequate liquid flow.

The flow switch used must have gold plated contacts for low voltage/current operation. Paddle type flow switches suitable for 150 PSIG (10 bar) working pressure and having a 1" N.P.T. connection can be obtained from YORK as an accessory for the unit. Alternatively, a differential pressure switch fitted across an orifice plate may be used, preferably of the high/low limit type.

The chilled liquid pump(s) installed in the piping system(s) should discharge directly into the unit cooler section of the system. The pump(s) may be controlled by the chiller controls or external to the unit. For details, refer to “Electrical Elementary and Connection Diagrams.”

Pipework and fittings must be separately supported to prevent any loading on the cooler. Flexible connections are recommended which will also minimize transmission of vibrations to the building. Flexible connections must be used if the unit is mounted on anti-vibration mounts, as some movement of the unit can be expected in normal operation.

Piping and fittings immediately next to the cooler should be readily de-mountable to enable cleaning before operation, and to facilitate visual inspection of the exchanger nozzles.

**The cooler must be protected by a strainer, preferably of 40 mesh, fitted as close as possible to the liquid inlet connection, and provided with a means of local isolation.**

The cooler must not be exposed to flushing velocities or debris released during flushing. It is recommended that a suitably sized bypass and valve arrangement is installed to allow flushing of the piping system. The bypass can be used during maintenance to isolate the heat exchanger without disrupting flow to other units.

Thermometer and pressure gauge connections should be provided on the inlet and outlet connections of each cooler. Gauges and thermometers are not provided with the unit.

Drain and air vent connections should be provided at all low and high points in the piping to permit drainage of the system and to vent any air in the pipes.

Liquid system lines at risk of freezing, due to low ambient temperatures should be protected using insulation and heater tape and/or a suitable glycol solution. The liquid pump(s) may also be used to ensure liquid is circulated when the ambient temperature approaches freezing point.

Insulation should also be installed around the cooler nozzles. Heater tape of 21 Watts per meter under the insulation is recommended, supplied independently and controlled by an ambient temperature thermostat set to switch ON at approximately 4°F, above the freezing temperature of the chilled liquid.

The cooler is protected by heater mats placed under the insulation, which are powered from the unit control system power supply. During cold weather when there is a risk of freezing, chiller power should be left switched on to provide the freeze protection function unless the liquid systems have been drained.

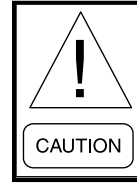

***Any debris left in the water piping between the strainer and cooler could cause serious damage to the tubes in the cooler and must be avoided. Be sure the piping is clean before connecting it to the evaporator. Keep evaporator nozzles and chilled liquid piping capped prior to installation to assure construction debris is not allowed to enter.***

***The installer/user must also ensure that the quality of the water in circulation is adequate, without any dissolved gases, which can cause oxidation of steel parts within the cooler.***

## WATER TREATMENT

The unit performance provided in the Design Guide is based on a fouling factor of 0.0001 ft<sup>2</sup>hr<sup>2</sup>/Btu (0.018m<sup>2</sup>/hr °C/kW). Dirt, scale, grease and certain types of water treatment will adversely affect the heat exchanger surfaces and therefore the unit performance. Foreign matter in the water system(s) can increase the heat exchanger pressure drop, reducing the flow rate and causing potential damage to the heat exchanger tubes.

Aerated, brackish or salt water is not recommended for use in the water system(s). Johnson Controls recommends that a water treatment specialist should be consulted to determine whether the proposed water composition will adversely affect the evaporator materials of carbon steel and copper. The pH value of the water flowing through the evaporator must be kept in a range between 7 and 8.5.

**PIPEWORK ARRANGEMENT**

The following is a suggested piping arrangement for single unit installations. For multiple unit installations, each unit should be piped as shown in FIG. 3.

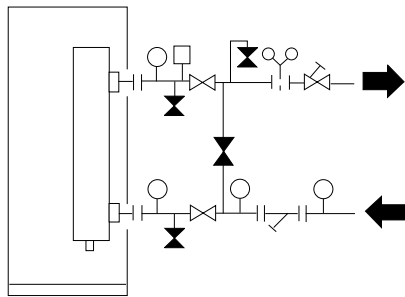

- ⊗ - Isolating Valve - Normally Open
- ⊠ - Isolating Valve - Normally Closed
- ⊗ - Flow Regulating Valve
- ⊙ - Flow Measurement Device
- ⊥ - Strainer
- ⊙ - Pressure Tapping
- ⊠ - Flow Switch
- ⊥ - Flanged Connection
- - Pipework

LD10507

**FIG. 3 - PIPEWORK ARRANGEMENT**

**CONNECTION TYPES AND SIZES**

For connection sizes relevant to individual models refer to the “Technical Data” section.

**COOLER CONNECTIONS**

Standard chilled liquid connections on all coolers are of the Victaulic Groove type (See FIG. 4).

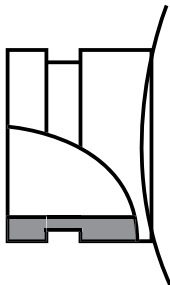

LD10494

**FIG. 4 - VICTAULIC GROOVE**

**Option Flanges**

One of two types of flanges may be fitted depending on the customer or local Pressure Vessel Code requirements. These are Victaulic-Adapter flanges, normally supplied loose, or weld flanges, which may be supplied loose or ready-fitted. Victaulic-Adapter and weld flange dimensions are to ISO 7005 - NP10.

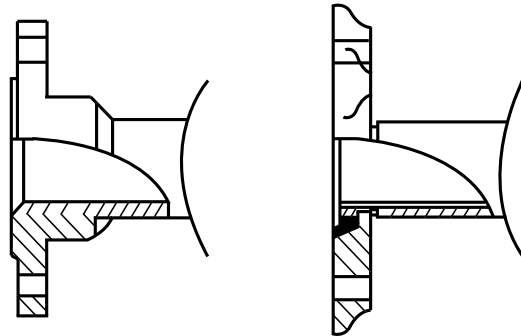

LD10495

**FIG. 5 - FLANGE ATTACHMENT**

**REFRIGERANT RELIEF VALVE PIPING**

The evaporator is protected against internal refrigerant overpressure by refrigerant relief valves. A pressure relief valve is mounted on each of the main refrigerant lines connecting the cooler to the compressors.

A piece of pipe is fitted to each valve and directed so that when the valve is activated the release of high pressure gas and liquid cannot be a danger or cause injury. For indoor installations, pressure relief valves should be piped to the exterior of the building.

The size of any piping attached to a relief valve must be of sufficient diameter so as not to cause resistance to the operation of the valve. Unless otherwise specified by local regulations. Internal diameter depends on the length of pipe required and is given by the following formula:

$$D^5 = 1.447 \times L$$

Where:

- D = minimum pipe internal diameter in cm
- L = length of pipe in meters

If relief piping is common to more than one valve, its cross-sectional area must be at least the total required by each valve. Valve types should not be mixed on a common pipe. Precautions should be taken to ensure the outlets of relief valves or relief valve vent pipes remain clear of obstructions at all times.

## DUCTWORK CONNECTION

### General Requirements

The following ductwork recommendations are intended to ensure satisfactory operation of the unit. Failure to follow these recommendations could cause damage to the unit, or loss of performance, and may invalidate the warranty.

When ducting is to be fitted to the fan discharge it is recommended that the duct should be the same cross-sectional area as the fan outlet and straight for at least three feet (1 meter) to obtain static regain from the fan. Ductwork should be suspended with flexible hangers to prevent noise and vibration being transmitted to the structure. A flexible joint is also recommended between the duct attached to the fan and the next section for the same reason. Flexible connectors should not be allowed to concertina.

The unit is not designed to take structural loading. No significant amount of weight should be allowed to rest on the fan outlet flange, deck assemblies or condenser coil module. No more than 3 feet (1 meter) of light construction ductwork should be supported by the unit. Where cross winds may occur, any ductwork must be supported to prevent side loading on the unit.

If the ducts from two or more fans are to be combined into a common duct, back-flow dampers should be fitted in the individual fan ducts. This will prevent recirculation of air when only one of the fans is running.

Units are supplied with outlet guards for safety and to prevent damage to the fan blades. If these guards are removed to fit ductwork, adequate alternative precautions must be taken to ensure persons cannot be harmed or put at risk from rotating fan blades.

## ELECTRICAL CONNECTION

The following connection recommendations are intended to ensure safe and satisfactory operation of the unit. Failure to follow these recommendations could cause harm to persons, or damage to the unit, and may invalidate the warranty.



***No additional controls (relays, etc.) should be mounted in the control panel. Power and control wiring not connected to the control panel should not be run through the control panel. If these precautions are not followed it could lead to a risk of electrocution. In addition, electrical noise could cause malfunctions or damage the unit and its controls.***



***After power wiring connection, do not switch on mains power to the unit. Some internal components are live when the mains are switched on and this must only be done by “Authorized” persons familiar with starting, operating, and troubleshooting this type of equipment.***

## POWER WIRING

All electrical wiring should be carried out in accordance with local regulations. Route properly sized cables to cable entries on the unit.

In accordance with local codes, NEC codes and U.L. Standards, it is the responsibility of the user to install over current protection devices between the supply conductors and the power supply terminals on the unit.

To ensure that no eddy currents are set up in the power panel, the cables forming the 3-phase power supply must enter via the same cable entry.



***All sources of supply to the unit must be taken via a common point of isolation (not supplied by Johnson Controls).***

Copper power wiring only should be used for supplying power to the chiller. This is recommended to avoid safety and reliability issues resulting from connection failure at the power connections to the chiller. Aluminum wiring is not recommended due to thermal characteristics that may cause loose terminations resulting from the contraction and expansion of the wiring. Aluminum oxide may also build up at the termination causing hot spots and eventual failure. If aluminum wiring is used to supply power to the chiller, AL-CU compression fittings should be used to transition from aluminum to copper. This transition should be done in an external box separate to the power panel. Copper conductors can then be run from the box to the chiller.

## POWER SUPPLY WIRING

Units require only one 3-phase supply, plus earth ground.

Connect the 3-phase supplies to the terminal block or optional circuit breaker located in the panel using lug sizes detailed in the “Technical Data” section (see *Figures 25, 31 and 32*).

Connect a ground wire from the chiller panel ground lug to the incoming line supply ground.

## 115VAC CONTROL SUPPLY TRANSFORMER

A 3-wire high voltage to 115VAC supply transformer is standard in the chiller. This transformer is mounted in the cabinet and steps down the high voltage supply to 115VAC to be used by the controls, VSD, Feed and Drain Valve Controller, valves, solenoids, heaters, etc.

The high voltage for the transformer primary is taken from the chiller input. Fusing is provided for the transformer.



***Removing high voltage power to the chiller will remove the 115VAC supply voltage to the control panel circuitry and the evaporator heater. In cold weather, this could cause serious damage to the chiller due to evaporator freeze-up. Do not remove power unless alternate means are taken to ensure operation of the evaporator heater.***

## CONTROL PANEL WIRING

All control wiring utilizing contact closures to the control panel terminal block is nominal 115VAC and must be run in shielded cable, with the shield grounded at the panel end only, and run in water tight conduit. Run shielded cable separately from mains cable to avoid electrical noise pick-up. Use the control panel cable entry to avoid the power cables.

Voltage free contacts connected to the panel must be suitable for 115VAC-10ma (gold contacts recommended). If the voltage free contacts form part of a relay or contactor, the coil of the device must be suppressed using a standard R/C suppressor. The above precautions must be taken to avoid electrical noise, which could cause a malfunction or damage to the unit and its controls.

## VOLTS FREE CONTACTS

Voltage free contacts are rated at 115VAC, 100VA resistive load only. Inductive loads must be suppressed across the coil.

### Chilled Liquid Pump Starter

Terminals 23 and 24 on 1TB (FIG. 31 and FIG. 32) close to start the chilled liquid pump. This contact can be used as a master start/stop for the pump in conjunction with the daily start/stop schedule.

### Run Contact

Terminals 21 and 22 on 1TB (FIG. 31 and FIG. 32) close to indicate that a system is running.

### Alarm Contacts

The Systems 1/3 and 2/4 each have a single voltage-free contact, which will operate to signal an alarm condition whenever any system locks out, or there is a power failure. To obtain system alarm signal, connect the alarm circuit to volt free Terminals 25 and 26 (Sys 1/3), Terminals 27 and 28 (Sys 2/4) of 1TB (FIG. 31 and FIG. 32).

## SYSTEM INPUTS

### Flow Switch

A chilled liquid flow switch of suitable type MUST be connected between Terminals 2 and 13 of 1TB (FIG. 31 and FIG. 32) to provide protection against loss of liquid flow, which will cause evaporator freeze-up if the chiller is permitted to run. The flow switch circuitry is a 115VAC circuit. Contacts must be rated for low current (10ma). Gold contacts should be used.

### Remote Run / Stop

A Remote Run/Stop input is available for each pair of systems (1/3 and 2/4). These inputs require a dry contact to start and stop the system. System 1/3 remote

dry contacts are connected between Terminals 2 and 15 of 1TB (FIG. 31 and FIG. 32) and System 2/4 dry contacts are connected between Terminals 2 and 16 of 1TB (FIG. 31 and FIG. 32). If remote start/stop is not utilized, a jumper must be placed across the terminals to allow the system to run. The remote run/stop circuitry is a 115VAC circuit. Contacts must be rated for low current (10ma). Gold contacts should be used.

### Remote Print

Closure of suitable contacts connected to Terminals 2 and 14 of 1TB (FIG. 31 and FIG. 32) will cause a hard copy printout of Operating Data/Fault History to be made if an optional printer is connected to the RS-232 port. The remote print circuitry is a 115VAC circuit. Contacts must be rated for low current (10ma). Gold contacts should be used.

### Optional Remote Setpoint Offset – Temperature

A current or voltage signal connected to Terminals 17 and 18 will provide a remote offset function of the chilled liquid setpoint, if required. *See FIG. 31 and FIG. 32 for the input location and Page 228 for a description of the option.*

### Optional Remote Setpoint Offset – Current

A current or voltage signal connected to Terminals 19 and 20 will provide remote setting of the current limit setpoint, if required. *See FIG. 31 and FIG. 32 for the input location and Page 230 for a description of the option.*

### Optional Remote Setpoint Offset – Sound Limiting

A current or voltage signal connected to Terminals 40 and 41 will provide remote setting of sound limit setpoint, if required. *See FIG. 31 and FIG. 32 for the input location and Page 231 for a description of the option.*

**THIS PAGE INTENTIONALLY LEFT BLANK**

## SECTION 5 - COMMISSIONING

### PREPARATION

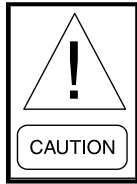

***Commissioning of this unit should only be carried out by Johnson Controls Authorized personnel.***

Commissioning personnel should be thoroughly familiar with the information contained in this document before starting the unit.

Commission the unit using the detailed checks outlined in the *Equipment Pre Start-up and Start-up Checklist* on Page 56.

### PREPARATION – GENERAL

The following basic checks should be made with the customer power to the unit switched OFF.



***Proper electrical lock out and tag procedures must be followed.***

### Inspection

Inspect unit for installation damage. If found, take action and/or repair as appropriate.

### Refrigerant Charge

Packaged units are normally shipped as standard with a full refrigerant operating charge. Check that refrigerant pressure is present in both systems and that no leaks are apparent. If no pressure is present, a leak test must be undertaken, the leak(s) located and repaired. Remote systems and units are supplied with a nitrogen holding charge. These systems must be evacuated with a suitable vacuum pump/recovery unit as appropriate to below 500 microns.

Do not liquid charge with static water in the cooler. Care must also be taken to liquid charge slowly to avoid excessive thermal stress at the charging point. Once the vacuum is broken, charge into the condenser coils with the full operating charge as given in the “Technical Data” section.

### Service and Oil Line Valves

Open each compressor suction, economizer, and discharge service valve. If valves are of the back-seat type, open them fully (counterclockwise) then close one turn of the stem to ensure operating pressure is fed to pressure transducers. Open the liquid line service valve and oil return line ball valve fully in each system.

### Compressor Oil

To add oil to a circuit - connect a YORK hand oil pump (Part No. 470-10654-000) to the 1/4" oil charging valve on the oil separator piping with a length of clean hose or copper line, but do not tighten the flare nut. Using clean oil of the correct type (“L” oil), pump oil until all air has been purged from the hose then tighten the nut. Stroke the oil pump to add oil to the oil system. The oil level should be between the middle of the lower and middle of the upper sight glasses of the oil separator. Approximately 4 to 5 gallons are present in each refrigerant system, with typically 1 to 2 gallons in each oil separator. Oil levels in the oil separators above the top sight glass in either oil separator should be avoided and may cause excessive oil carryover in the system. High oil concentration in the system may cause nuisance trips resulting from incorrect readings on the level sensor and temperature sensors. Temperature sensor errors may result in poor liquid control and resultant liquid overfeed and subsequent damage to the compressor.

### Fans

Check that all fans are free to rotate and are not damaged. Ensure blades are at the same height when rotated. Ensure fan guards are securely fixed.

### Isolation / Protection

Verify all sources of electrical supply to the unit are taken from a single point of isolation. Check that the maximum recommended fuse sizes given in the “Technical Data” section has not been exceeded.

### Control Panel

Check the panel to see that it is free of foreign materials (wire, metal chips, etc.) and clean out if required.

### Power Connections

Check that the customer power cables are connected correctly to the terminal blocks or optional circuit breaker. Ensure that connections of power cables within the panels to the circuit breaker or terminal blocks are tight.

## Grounding

Verify that the unit's protective ground terminal(s) are properly connected to a suitable grounding point. Ensure that all unit internal ground connections are tight.

## Water System

Verify the chilled liquid system has been installed correctly, and has been commissioned with the correct direction of water flow through the cooler. The inlet should be at the refrigerant piping connection end of the cooler. Purge air from the top of the cooler using the plugged air vent mounted on the top of the cooler body.

Flow rates and pressure drops must be within the limits given in the "Technical Data" section. Operation outside of these limits is undesirable and could cause damage.

If mains power must be switched OFF for extended maintenance or an extended shutdown period, the compressor suction, discharge and economizer service stop valves should be closed (clockwise). If there is a possibility of liquid freezing due to low ambient temperatures, the coolers should be drained or power should be applied to the chiller. This will allow the cooler heater to protect the cooler from freezing down to -20°F. Before placing the unit back in service, valves should be opened and power must be switched on (if power is removed for more than 8 hours) for at least 8 hours (24 hours if ambient temperature is below 86°F [30°C]) before the unit is restarted.

## Flow Switch

Verify a chilled water flow switch is correctly fitted in the customer's piping on the cooler outlet, and wired into the control panel correctly using shielded cable.

There should be a straight run of at least five pipe diameters on either side of the flow switch. The flow switch should be connected to Terminals 2 and 13 in the panel.

## Temperature Sensor(s)

Ensure the leaving liquid temperature sensor is coated with heat conductive compound (Part No. 013-00890-000) and is inserted to the bottom of the water outlet sensor well in the cooler. This sensor also provides some freeze protection and must always be fully inserted in the water outlet sensor well.

## Programmed Options

Verify that the options factory-programmed into the Micro Panel are in accordance with the customer's order requirements by pressing the OPTIONS key on the keypad and reading the settings from the display.

## Programmed Settings

Ensure the system cutout and operational settings are in accordance with the operating requirements by pressing the PROGRAM key.

## Date and Time

Program the date and time by first ensuring that the CLK jumper JP2 on the chiller control board is in the ON position. See Figures 26 and 27. Then press the DATE/TIME key and set the date and time (see Page 277).

## Start/Stop Schedule

Program the daily and holiday start/stop by pressing the SCHEDULE key (see Page 277).

## Setpoint and Remote Offset

Set the required leaving chilled liquid temperature setpoint and Control Range under the SETPOINTS key. The chilled liquid temperature control settings need to be set according to the required operating conditions.

If remote temperature reset (offset) is to be used, the maximum reset required must be programmed by pressing the SETPOINTS key (see Page 269).

## FIRST TIME START-UP



***During the commissioning period there should be sufficient heat load to run the unit under stable full load operation to enable the unit controls, and system operation to be set up correctly, and a commissioning log taken. Be sure that the chiller is properly programmed and the Equipment Pre Start-up and Start-up Checklist (Page 56) is completed.***

## Interlocks

Verify that liquid is flowing through the cooler and that heat load is present. Ensure that any remote run interlocks are in the run position and that the Daily Schedule requires the unit to run or is overridden.

## Unit Switch

Place the UNIT switch on the keypad to the ON position.

## Start-up

Press the SYSTEM SWITCHES key and place the system switch for System 1 to the ON position. There may be a few seconds delay before the first compressor starts because of the anti-recycle timer). Be ready when each compressor starts, to switch the UNIT switch OFF immediately, if any unusual noises or other adverse conditions develop.

When a compressor is running, the controller monitors oil pressure, motor current, and various other system parameters such as discharge pressure, chilled liquid temperature, etc. Should any problems occur, the control system will immediately take appropriate action and display the nature of the fault.

## Oil Pressure

When a compressor starts, press the relevant "System Pressures" key and verify that oil differential pressure (oil pressure-suction pressure) develops immediately. If oil pressure does not develop, the automatic controls will shut down the compressor. Under no circumstances should a restart attempt be made on a compressor, which does not develop oil pressure immediately. Switch the UNIT switch to the OFF position.

## Refrigerant Flow

When a compressor starts, a flow of liquid refrigerant will be seen in the liquid line sight glass. After several minutes of operation, and provided a full charge of refrigerant is in the system, the bubbles will disappear and be replaced by a solid column of liquid.

## Loading

Once the unit has been started, all operations are fully automatic. After an initial period at minimum capacity, the control system will adjust the unit load depending on the chilled liquid temperature and rate of temperature change. If a high heat load is present, the controller will increase the speed of the compressor(s).

## Condenser and Fan Rotation

Once a compressor is running, discharge pressure rises as refrigerant is pumped into the air-cooled condenser coils. This pressure is controlled by stages of fans to ensure maximum unit efficiency while maintaining sufficient pressure for correct operation of the condensers and the lubrication system.

As discharge pressure rises, the condenser fans operate in stages to control the pressure. Verify that the fans operate in the correct direction of rotation and operation is correct for the type of unit.

## Suction Superheat

Check suction superheat at steady full compressor load only. Measure suction temperature with a thermocouple on the copper line about 6" (150 mm) before the compressor suction service valve. Measure suction pressure at the suction transducer access valve or the compressor suction service valve. Superheat should be 10°F to 12°F (5.55 to 6.67°C) and should be reasonably close to the panel display. Superheat setting is programmable on the control panel, but is not mechanically adjustable. The Flash Tank Drain Valve controller modulates the 2 phase Drain Valve Stepper Motor to control system superheat. Superheat control is a function of suction pressure and suction temperature measurements from the sensors that are routed to the Chiller Control Board which in turn sends control signals to the Flash Tank Drain and Fill Valve Controller located in the left, back wall of the Chiller Controls Cabinet.

## Subcooling

Check liquid subcooling at steady full compressor load only. It is important that all fans are running for the system. Measure liquid line temperature on the copper line at the main liquid line service valve. Measure liquid pressure at the liquid line service valve. Subcooling should be 5 to 7°F (2.77 to 3.88°C). YCIV 0590 subcooling should be 10°F (5.55°C). No bubbles should show in the sight glass. If subcooling is out of range, add or remove refrigerant as required to clear the sight glass. Do not overcharge the unit. Subcooling should be checked with a flash tank level of approximately 35% with a clear sight glass.

## General Operation

After completion of the above checks for System 1, switch OFF the SYS 1 switch on the keypad and repeat the process for each subsequent system. When all run correctly, stop the unit, switch all applicable switches to the 'ON' position and restart the unit.

Assure all checks are completed in the Equipment Pre Start-up and Start-up Checklist (Pages 56 through 61). The chiller is then ready to be placed into operation.

**EQUIPMENT PRE-STARTUP AND STARTUP CHECKLIST**

JOB NAME: \_\_\_\_\_

SALES ORDER #: \_\_\_\_\_

LOCATION: \_\_\_\_\_

SOLD BY: \_\_\_\_\_

INSTALLING  
CONTRACTOR: \_\_\_\_\_

START-UP  
TECHNICIAN/  
COMPANY: \_\_\_\_\_

START-UP DATE: \_\_\_\_\_

CHILLER MODEL #: \_\_\_\_\_

SERIAL #: \_\_\_\_\_

COMPRESSOR #1  
MODEL#: \_\_\_\_\_

SERIAL #: \_\_\_\_\_

COMPRESSOR #2  
MODEL#: \_\_\_\_\_

SERIAL #: \_\_\_\_\_

COMPRESSOR #3  
MODEL#: \_\_\_\_\_

SERIAL #: \_\_\_\_\_

COMPRESSOR #4  
MODEL#: \_\_\_\_\_

SERIAL #: \_\_\_\_\_

**Pre Start-up**

**Unit Checks (No Power)**

The following basic checks should be made with the customer power to the unit switched off.



*Proper electrical lock out and tag procedures must be followed.*

Check the system 24 hours prior to initial start:

- 1. Inspect the unit for shipping or installation damage.
- 2. Ensure that all piping has been completed.
- 3. Assure the unit is properly charged and there are no piping leaks.
- 4. Open each system suction service valve, discharge service valve, economizer service valve, liquid line stop valve, and oil line ball valve.
- 5. The oil separator oil level(s) should be maintained so that an oil level is visible in either of the oil separator sight glasses when a compressor is running at high speeds for 10 to 15 minutes. An oil level may not be visible in the sight glasses when the compressor is off and it may be necessary to run the compressor to obtain a level. In shutdown situations and at some load points, much of the oil may be in the condenser and the level in the separators may fall below the bottom sight glass.

On systems with dual oil separators per compressor, one separator may show a lower level or no level, while the other separator shows a level between the 2 sight glasses. This is normal and a level is only required in one separator. Do not add oil to raise the level in the other oil separator.

Oil levels in single separator systems should not go above the top of the upper sight glass. Dual separator systems should also not show oil levels above the top of one of the sight glasses. In the rare situation where oil levels are high, drain enough oil to lower the level to the bottom of the top sight glass.

Sight glasses will vary in type depending upon the manufacturer of the separator. One type will have balls that float in the sight glasses to indicate level. Another type will have a bulls' eye glass. The bulls' eye glass will tend to appear to lose the lines in the bulls' eye when the level is above the

glass. Oil level should not be above the top sight glass. In the rare situation where oil levels are high, drain oil to lower the level to the bottom of the top sight glass.

Oil levels in the oil separators above the top sight glass in either oil separator should be avoided and may cause excessive oil carryover in the system. High oil concentration in the system may cause nuisance trips resulting from incorrect readings on the level sensor and temperature sensors. Temperature sensor errors may result in poor refrigerant control and liquid overfeed to the compressor.

In the unlikely event it is necessary to add oil, connect a YORK oil pump to the charging valve on the oil separator, but do not tighten the flare nut on the delivery tubing. With the bottom (suction end) of the pump submerged in oil to avoid entrance of air, operate the pump until oil drips from the flare nut joint, allowing the air to be expelled, and tighten the flare nut. Open the compressor oil charging valve and pump in oil until it reaches the proper level as described above.

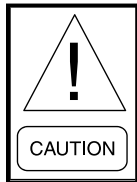

***When oil levels are high, adding oil may not visibly increase the level in the separators during operation. This may be an indication the level is already too high and the oil is being pumped out into the system where it will cause heat transfer and control problems.***

- ❑ 6. Ensure water pumps are on. Check and adjust water pump flow rate and pressure drop across the cooler.



***Excessive flow may cause catastrophic damage to the evaporator.***

- ❑ 7. Check the control panel to ensure it is free of foreign material (wires, metal chips, tools, documents, etc.).

- ❑ 8. Visually inspect wiring (power and control). Wiring MUST meet N.E.C. and local codes (*See FIG. 25, 31 and 32*).
- ❑ 9. Check tightness of the incoming power wiring inside the power panel and inside the motor terminal boxes.
- ❑ 10. Check for proper size fuses in control circuits.
- ❑ 11. Verify that field wiring matches the 3-phase power requirements of the chiller. (*See chiller nameplate Page 35*).
- ❑ 12. Be certain all water temperature sensors are inserted completely in their respective wells and are coated with heat conductive compound.
- ❑ 13. Ensure the suction line temperature sensors are strapped onto the suction lines at 4 or 8 O'clock positions.
- ❑ 14. Assure the glycol level in the VSD cooling system is 9 to 15 inches (23 to 28 cm) from the top of the fill tube. This check should be performed prior to running the pump.

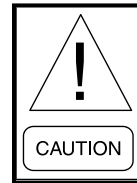

***Never run the glycol pump without coolant! Running the glycol pump without coolant may damage the pump seals.***

***Always fill the system with approved YORK coolant (P/N 013-03344-000) to avoid damage to the pump, cooling system and the chiller.***

- ❑ 15. Check to assure the remote start/stop for Sys #1 on Terminals 2 to 15 and Sys #2 on Terminals 2 to 16 are closed on the User Terminal Block 1TB to allow the systems to run. If remote cycling devices are not utilized, place a wire jumper between these terminals.
- ❑ 16. Ensure that the CLK jumper JP2 on the is in the ON position (*See FIG.-26 and 27*).
- ❑ 17. Assure a flow switch is connected between Terminals 2 and 13 on the User Terminal Block 1TB in the panel. Throttle back flow to assure the flow switch opens with a loss of flow. It is recommended that auxiliary pump contacts be placed in series with the flow switch for additional protection, if the pump is turned off during chiller operation. Whenever the pump contacts are used, the coil of the pump starter should be suppressed with an RC suppressor (031-00808-000).

**Start-up**

**Panel Checks**

**(Power ON – Both System Switches OFF)**



*You are about to turn power on to this machine. **SAFETY IS NUMBER ONE!** Only qualified individuals are permitted to service this product. The qualified individual furthermore is to be knowledgeable of, and adhere to, all safe work practices as required by **NEC, OSHA, and NFPA 70E**. Proper personal protection is to be utilized where and when required.*

- 1. Assure the chiller OFF/ON UNIT switch at the bottom of the keypad is OFF.
- 2. Apply 3-phase power to the chiller. Turn on the optional panel circuit breaker if supplied. The customer's disconnection devices can now be set to ON.
- 3. Verify the control panel display is illuminated.
- 4. To prevent the compressors from starting, assure that the system switches under the SYSTEM SWITCHES key are in the OFF position.
- 5. Verify that the voltage supply corresponds to the unit requirement and is within the limits given in the "Technical Data" section.
- 6. Ensure the heaters on each compressor are ON using a clamp-on ammeter. Heater current draw is approx. 3A.
- 7. Verify the "Factory Set" overload potentiometers on the VSD Logic Board are set correctly (correct settings are provided on Page 323). Press the VSD DATA key and using the arrow keys, scroll to the compressor overload settings. Verify the "Factory Set" overload potentiometer(s) on the VSD Logic Board (see FIG. 29 and 30) are set correctly. In the unlikely event that they are not set correctly, adjust the potentiometers until the desired values are achieved.



*The VSD is powered up and live. High voltage exists in the area of the circuit board on the bus bars, VSD Pole Assemblies, and wiring to the input inductor.*

Adjust the potentiometers, if needed, using the table on Page 323. The locations of the potentiometers are shown in FIG. 29 and 30. The potentiometers are Sys 1=R19, Sys 2=R64, Sys 3=R42, and Sys 4=R86.

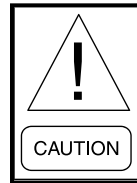

*Incorrect settings of the potentiometers may cause damage to the equipment.*

Record the Overload Potentiometer settings below:

Compressor Overload Setting:

System 1 = \_\_\_\_\_ Amps

System 2 = \_\_\_\_\_ Amps

System 3 = \_\_\_\_\_ Amps

System 4 = \_\_\_\_\_ Amps

- 8. Press the STATUS key. If the following message appears, immediately contact Johnson Controls Product Technical Support. The appearance of this message may mean the chiller has lost important factory programmed information. The serial number and other important data may need to be reprogrammed.

**UNIT WARNING: INVALID SERIAL NUMBER  
ENTER UNIT SERIAL NUMBER**

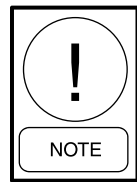

*Changing the programming of this feature requires the date and time to be set on the chiller prior to programming. Additional information regarding this message and how to enter the serial number with the factory provided password is outlined in the "Serial Number Programming" information on Page 292.*

If the following message appears when the STATUS key is pressed, immediately contact Johnson Controls Product Technical Support. The appearance of this message indicates the chiller is a High IPLV chiller operating in Standard IPLV control.

**UNIT WARNING: OPTIMIZED EFFICIENCY  
DISABLED – CONTACT YORK REPRESENTATIVE**

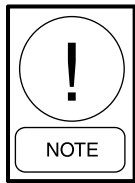

**Changing the programming of this feature requires the date and time to be set on the chiller prior to programming. Additional information regarding this message is provided in the “Enabling Optimized High IPLV Mode” information on Page 293.**

9. Program the required options into the Panel for the desired operating requirements (see Page 274). Record the values below:

Display Language = \_\_\_\_\_

Chilled Liquid Mode = \_\_\_\_\_

Local/Remote Mode = \_\_\_\_\_

Display Units = \_\_\_\_\_

Lead/Lag Control = \_\_\_\_\_

Remote Temperature Reset = \_\_\_\_\_

Remote Current Reset = \_\_\_\_\_

Remote Sound Limit = \_\_\_\_\_

Low Ambient Cutout = \_\_\_\_\_



**Damage to the chiller could result if the options are improperly programmed.**

### Programmed Values

10. Program the required operating values into the microprocessor for cutouts, safeties, etc. and record them in the chart below (see Page 271 for details).

Suction Pressure Cutout = \_\_\_\_\_ PSIG (kPa)

Low Ambient Cutout = \_\_\_\_\_ °F (°C)

Leaving Chilled Liquid  
Temperature Cutout = \_\_\_\_\_ °F (°C)

Motor Current Limit = \_\_\_\_\_ % FLA

Pulldown Current Limit Time = \_\_\_\_\_ MIN

Suction Superheat Setpoint = \_\_\_\_\_ °F (°C)

Remote Unit ID # = \_\_\_\_\_

Sound Limit Setpoint = \_\_\_\_\_ %

### Chilled Liquid Setpoint

11. Program the Chilled Liquid Setpoint/Range and record:

Local Cooling Setpoint = \_\_\_\_\_ °F (°C)

Local Cooling Range = \_\_\_\_\_ to \_\_\_\_\_ °F (°C)

Maximum Remote

Temperature Reset = \_\_\_\_\_ to \_\_\_\_\_ °F (°C)

### Date/Time, Daily Schedule, and Clock Jumper

12. Set the date and time.
13. Program the Daily Schedule start and stop times.
14. Place the panel in Service Mode (see Page 285) and turn on each fan stage one by one. Ensure the fans rotate in the correct direction, so air flow exits the top of the chiller
15. Remove the cap on the fill tube and run the glycol pump to verify the level in the fill tube. Ensure the glycol level in the VSD cooling system is 9 to 15 inches (23 to 28 cm) from the top of the fill tube while running. The pump can be run by placing the chiller in the Service Mode. Be sure to re-install the cap before stopping the glycol pump to avoid overflowing the fill tube when the glycol pump is turned off. The glycol system holds about 3.5 gallons of coolant (P/N 013-03344-000) on the largest chiller model.

### Initial Start-up

After the control panel has been programmed and the compressor heaters have been energized for at least 8 hours (ambient temperature more than 96°F (36°C)) or 24 hours (ambient temperature less than 86°F (30°C)), the chiller may be placed in operation.

1. Turn on the UNIT switch and program the system switches on the keypad to the “ON” position.
2. If cooling demand permits, the compressor(s) will start and a flow of refrigerant will be noted in the sight glass, after the anti recycle timer times out and the precharge of the DC Bus is completed. After several minutes of operation, the bubbles in the sight glass will disappear and there will be a solid column of liquid when the Drain and Feed Valves stabilize the flash tank level.

- ❑ 3. Allow the compressor to run a short time, being ready to stop it immediately if any unusual noise or adverse conditions develop. Immediately at start-up, the compressor may make sounds different from its normal high-pitched sound. This is due to the compressor coming up to speed and the initial lack of an oil film sealing the clearances in the rotors. This should be of no concern and lasts for only a short time.
- ❑ 4. Check the system operating parameters. Do this by selecting various displays such as pressures and temperatures. Compare these to test gauge readings.

**Checking Subcooling and Superheat**

The subcooling should always be checked when charging the system with refrigerant and/or before checking the superheat. The subcooling measurement should always be taken with the system loaded, the economizer solenoid energized, and the level in the flash tank reasonably stable with a level of approximately 35%.

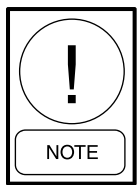

*It may be desirable to check subcooling with one compressor running to allow the compressor to operate at full speed for a period of time to stabilize system temperatures and pressures.*

When the refrigerant charge is correct, there will be no bubbles in the liquid sight glass with the system operating under full load conditions, and there will be 5 to 7°F (2.77 to 3.78°C) subcooled liquid leaving the condenser. Subcooling should be set at 10°F (5.56°C). An overcharged system should be guarded against. Evidence of overcharge is as follows:

- a. If a system is overcharged, the discharge pressure will be higher than normal. Normal discharge/condensing pressure can be found in the refrigerant temperature/pressure chart; use entering air temperature plus 30°F (17°C) for normal condensing temperature.
- b. The temperature of the liquid refrigerant out of the condenser should be about 5 to 7°F (2.77 to 3.78°C) less than the condensing temperature (The temperature corresponding to the condensing pressure from the refrigerant temperature/pressure chart).

The subcooling temperature of each system should be calculated by recording the temperature of the liquid line at the outlet of the condenser and subtracting it from the recorded liquid line pressure at the liquid stop valve, converted to temperature from the temperature/pressure chart.

**Subcooling**

Example:

Liquid line pressure =  
 110 PSIG converted to            93°F (33.9°C)  
 Minus liquid line temp.        -87°F (30.6°C)  
 Subcooling =                        6°F (3.3°C)

The subcooling should be adjusted between 5 and 7 °F (2.77 and 3.78°C)

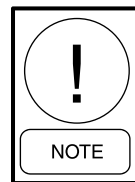

*This may be difficult to measure, due to test instrument error and the difficulty generally encountered when measuring subcooling on systems operating with very low condenser subcooling.*

- ❑ 1. Record the liquid line pressure and it's corresponding temperature, liquid line temperature, and subcooling below:

	SYS 1	SYS 2	
Liq Line Press =	_____	_____	PSIG (kPa)
Temp =	_____	_____	°F (°C)
Liq Line Temp =	_____	_____	°F (°C)
Subcooling =	_____	_____	°F (°C)

Add or remove charge as necessary to obtain a full sight glass fully loaded while keeping subcooling to about 5 to 7°F (2.77 to 3.78°C). After an adjustment is made to the charge, the flash tank level may rise or drop from the approx. 35% point. Before another measurement is made, allow the level to stabilize.

After the subcooling is set, the suction superheat should be checked. The superheat should be checked only after steady state operation of the chiller has been established, and the system is running in a fully loaded, stable condition. Correct superheat for a system is

between 8 and 12°F (4.45 and 6.67°C) and should be reasonably close to the system superheat on the chiller display.

The superheat is calculated as the difference between the actual temperature of the returned refrigerant gas in the suction line entering the compressor and the temperature corresponding to the suction pressure as shown in a standard pressure/temperature chart.

**Superheat**

Example:

$$\begin{array}{r}
 \text{Suction Temp} = \qquad\qquad\qquad 46^{\circ}\text{F} (8^{\circ}\text{C}) \\
 \text{minus Suction Press} \\
 30 \text{ PSIG converted to Temp} \quad - 35^{\circ}\text{F} (1^{\circ}\text{C}) \\
 \qquad\qquad\qquad\qquad\qquad\qquad 11^{\circ}\text{F} (6^{\circ}\text{C})
 \end{array}$$

The suction temperature should be taken 6" (13 mm) before the compressor suction service valve, and the suction pressure is taken at the compressor suction service valve.

No superheat adjustments are necessary and the electronically controlled Drain Valve need not be adjusted in the field. Ensure that superheat is controlling at 8 to 12°F (4.45 to 6.67°C). The purpose of this check is primarily to verify the transducer and suction temperature sensors in a system are providing reasonably accurate outputs to the chiller controls. It also checks the operation of the Feed and Drain Valves.

- 2. Record the suction temperature, suction pressure, suction pressure converted to temperature, and

superheat of each system below:

	SYS 1	SYS 2	
Suction Press =	_____	_____	PSIG (kPa)
SP to Temp =	_____	_____	°F (°C)
Suction Temp =	_____	_____	°F (°C)
Superheat =	_____	_____	°F (°C)

- 3. Discharge superheat will typically run approx. 28 to 30°F. This can be checked on the micropanel display. If the suction superheat drops very low or the economizer feeds liquid into the compressor, the superheat will drop sharply to approx. 2 to 3°F.

**Leak Checking**

- 1. Leak check compressors, fittings, and piping to ensure no leaks.

If the chiller is functioning satisfactorily during the initial operating period, no safeties trip and the chiller controls chilled liquid temperature; it is now ready to be placed into service.

**5**

**THIS PAGE INTENTIONALLY LEFT BLANK**

## SECTION 6 - TECHNICAL DATA

### WATER PRESSURE DROP CHARTS

#### ENGLISH UNITS

Pressure Drop Through Two Circuit YCIV Evaporators

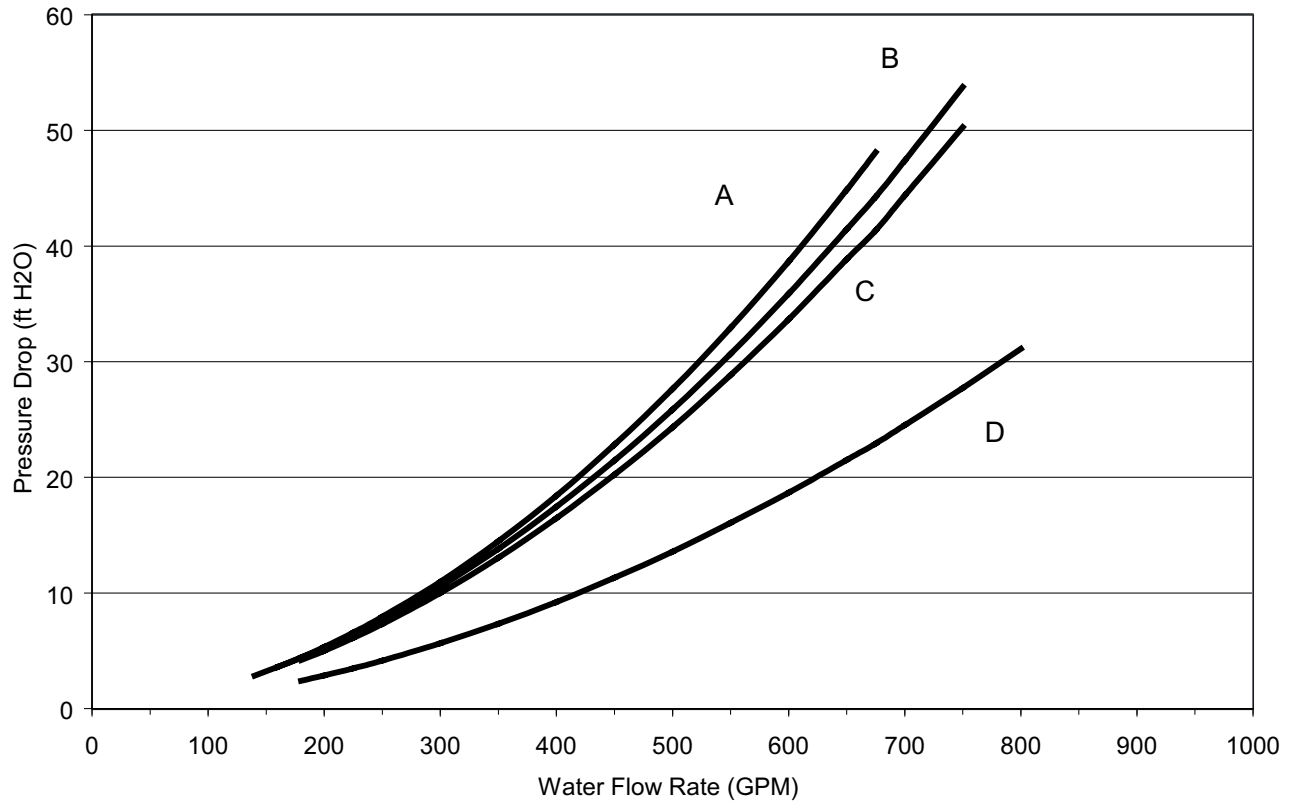

6

COOLER	MODEL NUMBER YCIV
	50Hz
A	0600(S/P)
	0590(E/V)
B	0630(E/V), 0650(S/P)
	0700(E/V), 0720(S/P)
C	0760(E/V)
	0800(E/V)
	0830(E/V)
D	0770(S/P)
	0840(S/P)
	0920(S/P), 0930(E/V)
	1000(S/P)

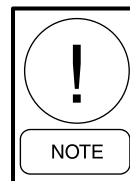

*Excessive flow, above the max. GPM, will damage the evaporator.*

**WATER PRESSURE DROP CHARTS(CONT'D)**

**SI UNITS**

Pressure Drop Through Two Circuit YCIV Evaporators

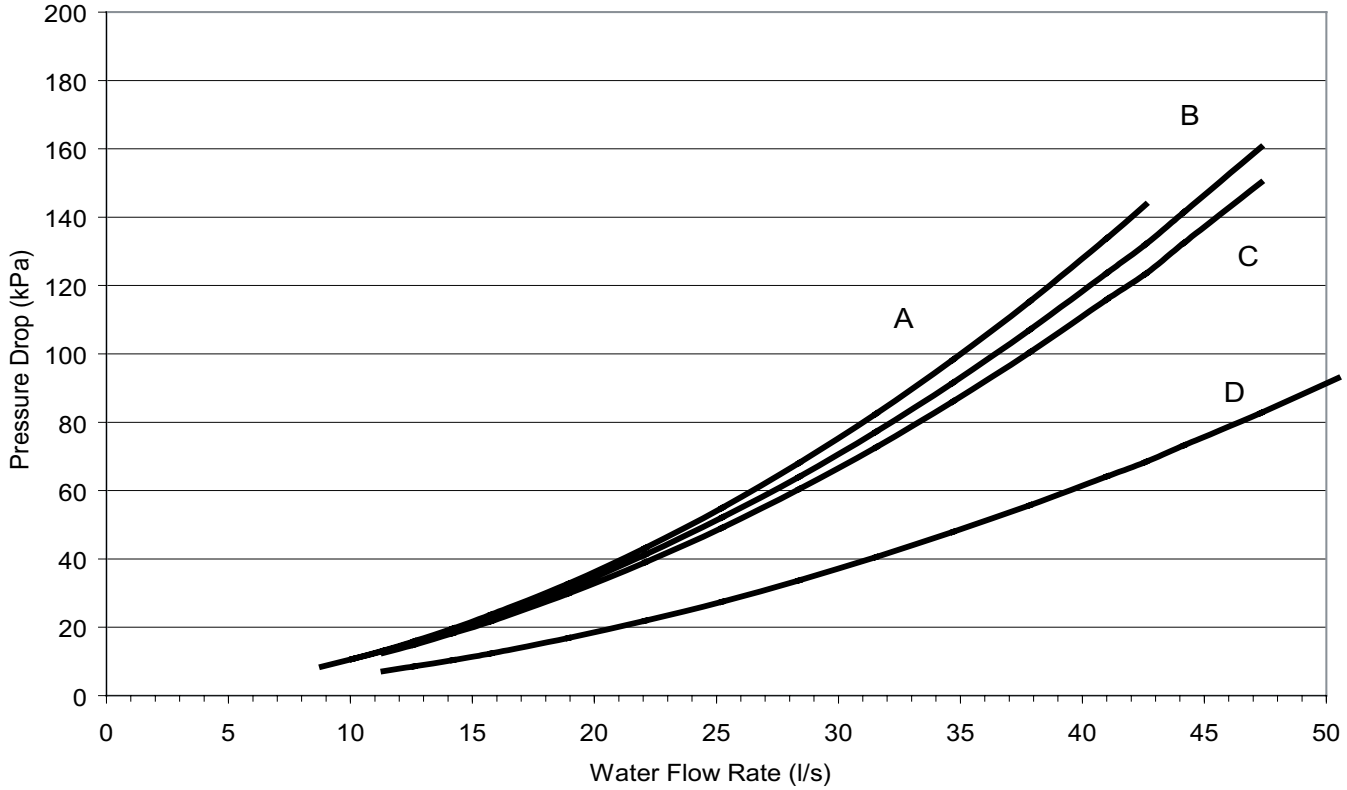

COOLER	MODEL NUMBER YCIV
	50Hz
A	0600(S/P)
	0590(E/V)
B	0630(E/V), 0650(S/P)
	0700(E/V), 0720(S/P)
C	0760(E/V)
	0800(E/V)
	0830(E/V)
D	0770(S/P)
	0840(S/P)
	0920(S/P), 0930(E/V)
	1000(S/P)

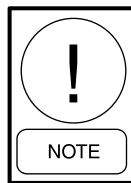

*Excessive flow, above the max. GPM, will damage the evaporator.*

# WATER PRESSURE DROP CHARTS

## ENGLISH UNITS

Pressure Drop Through Three Circuit YCIV Evaporators

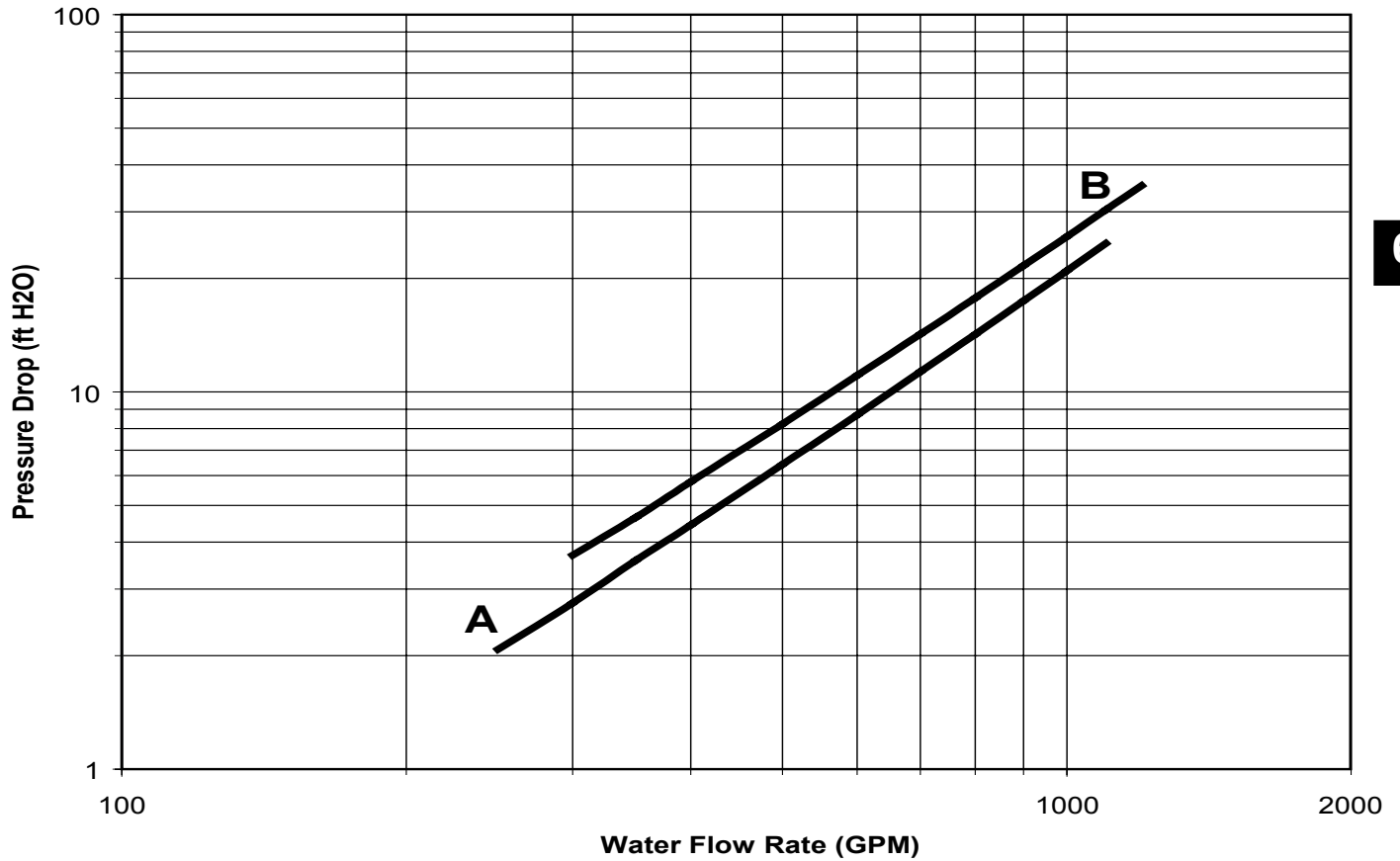

6

EVAP	YCIV MODELS
	50Hz
A	1050(E/V)
	1070(S/P)
	1120(E/V)
B	1180(S/P)
	1220(E/V)
	1340(S/P)
	1380(E/V)
	1500(S/P)

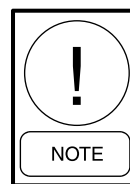

*Excessive flow, above the max. GPM, will damage the evaporator.*

# WATER PRESSURE DROP CHARTS (CONT'D)

## SI UNITS

Pressure Drop Through Three Circuit YCIV Evaporators

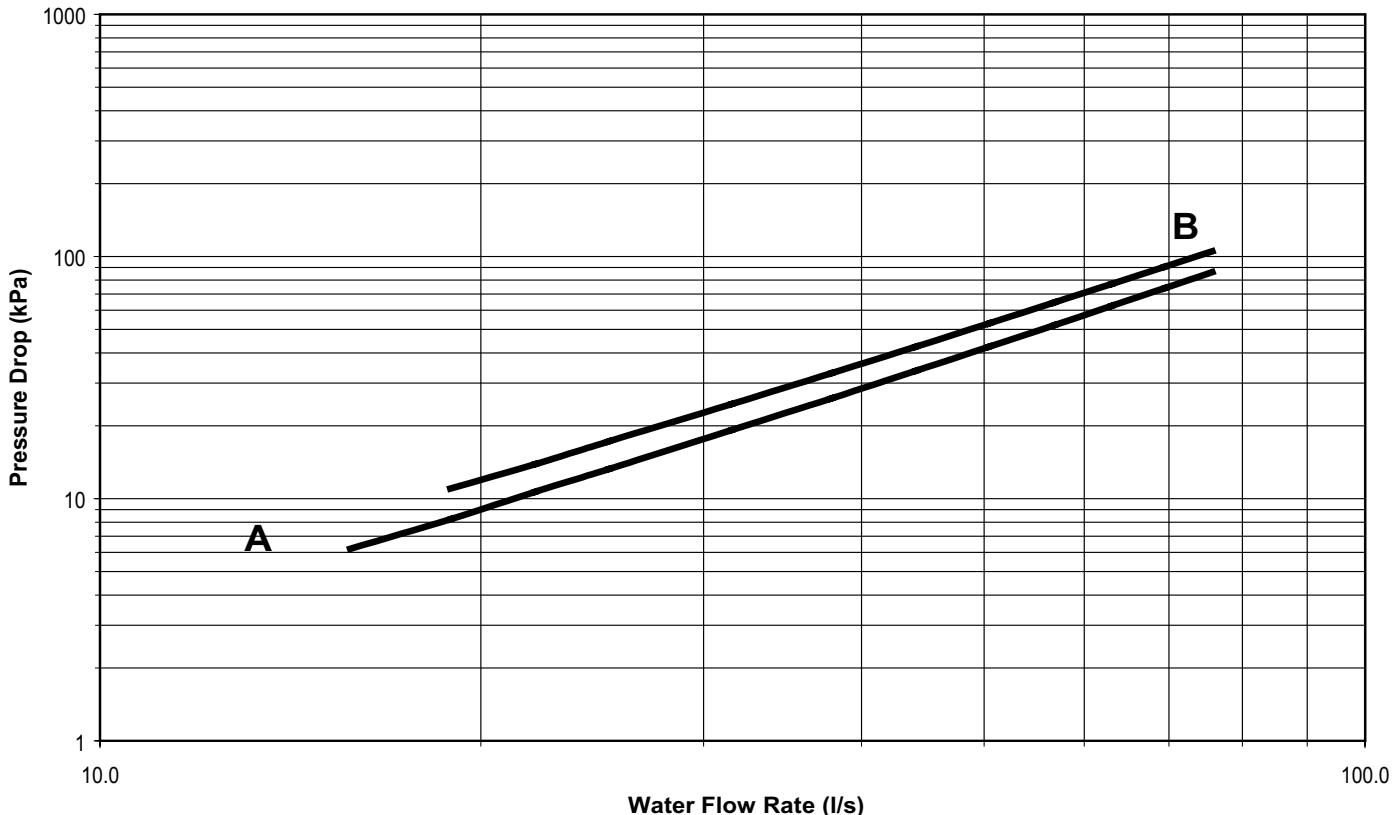

EVAP	YCIV MODELS
	50Hz
A	1050(E/V)
	1070(S/P)
	1120(E/V)
B	1180(S/P)
	1220(E/V)
	1340(S/P)
	1380(E/V)
	1500(S/P)

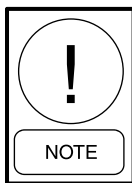

**Excessive flow, above the max. GPM, will damage the evaporator.**

## GLYCOL CORRECTION FACTORS

The cooler is designed in accordance with ARI-590-92 which allows for an increase in pressure drop of up to 15% above the design value shown on Pages 63 through 66. Debris in the water may also cause additional pressure drop.

When using glycol solutions, pressure drops are higher than with water (see correction factors to be applied when using glycol solutions). Special care must be taken not to exceed the maximum flow rate allowed.

A = Correction Factor

B = Mean Temperature through Cooler

C = Concentration WIW

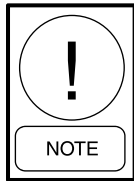

**Excessive flow, above the max. GPM, will damage the evaporator.**

### GLYCOL CORRECTION FACTORS

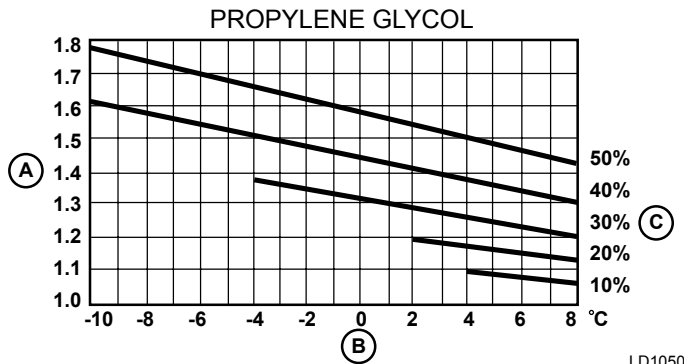
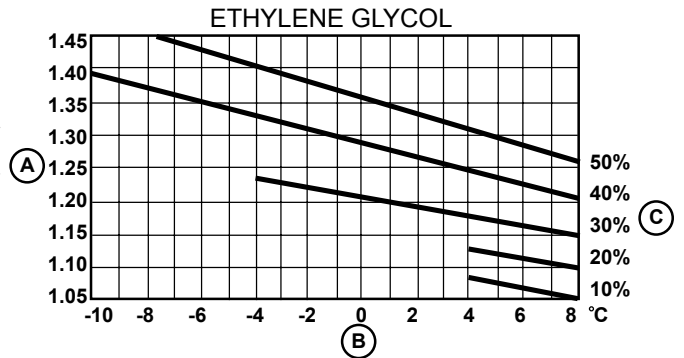

LD10500A

**WATER TEMPERATURE AND FLOWS**  
(English Units)

MODEL NUMBER Y/CIV	LEAVING WATER TEMPERATURE (°F)		COOLER <sup>3</sup> FLOW (GPM)		AIR ON CONDENSER (°F)	
	MIN. <sup>1</sup>	MAX. <sup>2</sup>	MIN.	MAX.	MIN.	MAX
0600(S/P)	40	60	140	675	0	125
0590(E/V)	40	60	160	750	0	125
0650(S/P)	40	60	160	750	0	125
0630(E/V)	40	60	160	750	0	125
0720(S/P/I)	40	60	160	750	0	125
0700(E/V)	40	60	160	750	0	125
0760(E/V)	40	60	180	750	0	125
0770(S/P)	40	60	180	800	0	125
0800(E/V)	40	60	180	750	0	125
0840(S/P)	40	60	180	800	0	125
0830(E/V)	40	60	180	750	0	125
0920(S/P)	40	60	180	800	0	125
0930(E/V)	40	60	180	800	0	125
1000(S/P)	40	60	180	800	0	125
1050(E/V)	40	60	250	1200	0	125
1070(S/P)	40	60	250	1200	0	125
1120(E/V)	40	60	250	1200	0	125
1180(S/P)	40	60	300	1200	0	125
1220(E/V)	40	60	300	1200	0	125
1340(S/P)	40	60	300	1200	0	125
1380(E/V)	40	60	300	1200	0	125
1500(S/P)	40	60	300	1200	0	125

**NOTES:**

1. For leaving brine temperature below 40°F (4.4°C), contact your nearest Johnson Controls office for application requirements.
2. For leaving water temperature higher than 60°F (15.6°C), contact the nearest Johnson Controls office for application guidelines.
3. The evaporator is protected against freezing to -20°F (-28.8°C) with an electric heater as standard.

**WATER TEMPERATURE AND FLOWS (CONT'D)****(SI Units)**

MODEL NUMBER YCI V	LEAVING WATER TEMPERATURE (°C)		COOLER <sup>3</sup> FLOW (l/s)		AIR ON CONDENSER (°C)	
	MIN. <sup>1</sup>	MAX. <sup>2</sup>	MIN.	MAX.	MIN.	MAX
0600(S/P)	4.4	15.6	8.8	42.6	-17.8	51.7
0590(E/V)	4.4	15.6	10.1	47.3	-17.8	51.7
0650(S/P)	4.4	15.6	10.1	47.3	-17.8	51.7
0630(E/V)	4.4	15.6	10.1	47.3	-17.8	51.7
0720(S/P)	4.4	15.6	10.1	47.3	-17.8	51.7
0700(E/V)	4.4	15.6	10.1	47.3	-17.8	51.7
0760(E/V)	4.4	15.6	11.4	47.3	-17.8	51.7
0770(S/P)	4.4	15.6	11.4	50.5	-17.8	51.7
0800(E/V)	4.4	15.6	11.4	47.3	-17.8	51.7
0840(S/P)	4.4	15.6	11.4	50.5	-17.8	51.7
0830(E/V)	4.4	15.6	11.4	47.3	-17.8	51.7
0920(S/P)	4.4	15.6	11.4	50.5	-17.8	51.7
0930(E/V)	4.4	15.6	10.1	47.3	-17.8	51.7
1000(S/P)	4.4	15.6	11.4	50.5	-17.8	51.7
1050(E/V)	4.4	15.6	11.4	50.5	-17.8	51.7
1070(S/P)	4.4	15.6	15.8	75.7	-17.8	51.7
1120(E/V)	4.4	15.6	15.8	75.7	-17.8	51.7
1180(S/P)	4.4	15.6	18.9	75.7	-17.8	51.7
1220(E/V)	4.4	15.6	18.9	75.7	-17.8	51.7
1340(S/P)	4.4	15.6	18.9	75.7	-17.8	51.7
1380(E/V)	4.4	15.6	18.9	75.7	-17.8	51.7
1500(S/P)	4.4	15.6	18.9	75.7	-17.8	51.7

**NOTES:**

1. For leaving brine temperature below 4.4°C, contact your nearest Johnson Controls office for application requirements.
2. For leaving water temperature higher than 15.6°C, contact the nearest Johnson Controls office for application guidelines.
3. The evaporator is protected against freezing to -28.8°C with an electric heater as standard.

**PHYSICAL DATA (ENGLISH - STANDARD EFFICIENCY)**

Refrigerant R-134a	STANDARD EFFICIENCY							
	MODEL NUMBER (YCIV _____ S/P)							
	50Hz	0600	0650	0720	0770	0840	0920	1000
<b>General Unit Data</b>								
Number of Independent Refrigerant Circuits	2	2	2	2	2	2	2	2
Refrigerant Charge, R-134a, Ckt.-1/Ckt.-2, lbs	162/162	170/170	185/170	192/175	192/192	230/195	230/230	230/230
Oil Charge, Ckt.-1/Ckt.-2, gal.	5/5	5/5	5/5	5/5	5/5	5/5	5/5	5/5
Compressors, Semi-hermetic Screw Qty per Chiller	2	2	2	2	2	2	2	2
<b>Condensers, High Efficiency Fin/Tube with Integral Subcooler</b>								
Total Chiller Coil Face Area, ft <sup>2</sup>	235	235	264	264	293	323	352	352
Number of Rows	3	3	3	3	3	3	3	3
Fins per Inch	17	17	17	17	17	17	17	17
<b>Condenser Fans</b>								
Number, Ckt.-1/Ckt.-2	4/4	4/4	5/4	5/4	5/5	6/5	6/6	6/6
<b>Low Noise Fans</b>								
Fan Motor, HP	2	2	2	2	2	2	2	2
Total Chiller Airflow, cfm	104000	104000	117000	117000	130000	143000	156000	156000
<b>Ultra Quiet Fans</b>								
Fan Motor, HP	2	2	2	2	2	2	2	2
Total Chiller Airflow, cfm	104000	104000	117000	117000	130000	143000	156000	156000
<b>Dual Speed Fans - Normal Speed</b>								
Fan Motor, hp	2	2	2	2	2	2	2	2
Total Chiller, CFM	88000	88000	99000	99000	110000	121000	132000	132000
<b>Dual Speed Fans - Lower Speed</b>								
Fan Motor, hp	2	2	2	2	2	2	2	2
Total Chiller, CFM	67200	67200	75600	75600	84000	92400	100800	100800
<b>High Static Fans</b>								
Fan Motor, hp	5	5	5	5	5	5	5	5
Total Chiller, CFM	104000	104000	117000	117000	130000	143000	156000	156000
<b>Evaporator, Direct Expansion</b>								
Water Volume, gals.	67.0	95.0	95.0	140.0	140.0	140.0	140.0	140.0
Maximum Water Side Pressure, PSIG	150	150	150	150	150	150	150	150
Maximum Refrigerant Side Pressure, PSIG	235	235	235	235	235	235	235	235
Minimum Chilled Water Flow Rate, gpm	140	160	160	180	180	180	180	180
Maximum Chilled Water Flow Rate, gpm	675	750	750	800	800	800	800	800
Water Connections, inches	8	10	10	10	10	10	10	10

Contact your nearest Johnson Controls Sales Office for weight data.

## PHYSICAL DATA (ENGLISH - STANDARD EFFICIENCY) (CONT'D)

Refrigerant R-134a	STANDARD EFFICIENCY				
	MODEL NUMBER (YCIV ___ S/P)				
General Unit Data	50Hz	1070	1180	1340	1500
Number of Independent Refrigerant Circuits		3	3	3	3
Refrigerant Charge, R-134a, Ckt.-1/Ckt.-2, lbs		185/170/170	185/185/170	185/185/230	230/230/230
Oil Charge, Ckt.-1/Ckt.-2, gal.		5/4/4	5/4/4	5/5/5	5/5/5
Glycol Charge (43% concentration), gal		5.4	5.5	6.0	6.3
<b>Comp.s, Semihermetic Screw</b>					
Quantity per Chiller		3	3	3	3
<b>Condensers, High Efficiency Fin/Tube with Integral Subcooler</b>					
Total Chiller Coil Face Area, ft <sup>2</sup>		381	411	469	528
Number of Rows		3	3	3	3
Fins per Inch		17	17	17	17
<b>Condenser Fans</b>					
Number, Ckt.-1/Ckt.-2		5/4/4	5/4/4	5/5/6	6/6/6
<b>Low Noise Fans</b>					
Fan Motor, HP/kWi		2/1.8	2/1.8	2/1.8	2/1.8
Total Chiller Airflow, cfm		169000	182000	208000	234000
<b>Ultra Quiet Fans</b>					
Fan Motor, HP/kWi		2/1.50	2/1.50	2/1.50	2/1.50
Total Chiller Airflow, cfm		169000	182000	208000	234000
<b>Dual Speed Fans - Normal Speed</b>					
Fan Motor, hp		2	2	2	2
Total Chiller, CFM		143000	143000	165000	165000
<b>Dual Speed Fans - Lower Speed</b>					
Fan Motor, hp		2	2	2	2
Total Chiller, CFM		109200	109200	126000	126000
<b>High Static Fans</b>					
Fan Motor, hp		5	5	5	5
Total Chiller, CFM		169000	182000	208000	234000
<b>Evaporator, Direct Expansion</b>					
Water Volume, gals.		202.0	236.0	236.0	236.0
Maximum Water Side Pressure, PSIG		150	150	150	150
Maximum Refrigerant Side Pressure, PSIG		235	235	235	235
Minimum Chilled Water Flow Rate, gpm		250	300	300	300
Maximum Chilled Water Flow Rate, gpm		1200	1200	1200	1200
Water Connections, inches		10	10	10	10

Contact your nearest Johnson Controls Sales Office for weight data.

**PHYSICAL DATA (ENGLISH - HIGH EFFICIENCY)**

Refrigerant R-134a	HIGH EFFICIENCY							
	MODEL NUMBER (YCIV _____ E/V)							
	50Hz	0590	0630	0700	0760	0800	0830	0930
<b>General Unit Data</b>								
Number of Independent Refrigerant Circuits	2	2	2	2	2	2	2	2
Refrigerant Charge, R-134a, Ckt.-1/Ckt.-2, lbs	170/170	185/170	185/185	192/192	225/192	225/225	230/230	230/230
Oil Charge, Ckt.-1/Ckt.-2, gal.	5/5	5/5	5/5	5/5	5/5	5/5	5/5	5/5
Compressors, Semihermetic Screw Qty per Chiller	2	2	2	2	2	2	2	2
<b>Condensers, High Efficiency Fin/Tube with Integral Subcooler</b>								
Total Chiller Coil Face Area, ft <sup>2</sup>	235	264	293	293	323	352	352	352
Number of Rows	3	3	3	3	3	3	3	3
Fins per Inch	17	17	17	17	17	17	17	17
<b>Condenser Fans</b>								
Number, Ckt.-1/Ckt.-2	4/4	5/4	5/5	5/5	6/5	6/6	6/6	6/6
<b>Low Noise Fans</b>								
Fan Motor, HP	2	2	2	2	2	2	2	2
Total Chiller Airflow, cfm	104000	117000	130000	130000	143000	156000	156000	156000
<b>Ultra Quiet Fans</b>								
Fan Motor, HP	2	2	2	2	2	2	2	2
Total Chiller Airflow, cfm	104000	117000	130000	130000	143000	156000	156000	156000
<b>Dual Speed Fans - Normal Speed</b>								
Fan Motor, hp	2	2	2	2	2	2	2	2
Total Chiller, CFM	88000	99000	110000	110000	121000	132000	132000	132000
<b>Dual Speed Fans - Lower Speed</b>								
Fan Motor, hp	2	2	2	2	2	2	2	2
Total Chiller, CFM	67200	75600	84000	84000	92400	100800	100800	100800
<b>High Static Fans</b>								
Fan Motor, hp	5	5	5	5	5	5	5	5
Total Chiller, CFM	104000	117000	130000	130000	143000	156000	156000	156000
<b>Evaporator, Direct Expansion</b>								
Water Volume, gals.	95.0	95.0	95.0	110.0	110.0	110.0	140.0	140.0
Maximum Water Side Pressure, PSIG	150	150	150	150	150	150	150	150
Maximum Refrigerant Side Pressure, PSIG	235	235	235	235	235	235	235	235
Minimum Chilled Water Flow Rate, gpm	160	160	160	180	180	180	180	180
Maximum Chilled Water Flow Rate, gpm	750	750	750	750	750	750	800	800
Water Connections, inches	10	10	10	10	10	10	10	10

## PHYSICAL DATA (ENGLISH - HIGH EFFICIENCY) (CONT'D)

<b>Refrigerant R-134a</b>	<b>HIGH EFFICIENCY</b>				
	<b>MODEL NUMBER (YCIV ___ E/V)</b>				
<b>General Unit Data</b>	<b>50Hz</b>	<b>1050</b>	<b>1120</b>	<b>1220</b>	<b>1380</b>
Number of Independent Refrigerant Circuits	3	3	3	3	3
Refrigerant Charge, R-134a, Ckt.-1/Ckt.-2, lbs	185/185/170	185/185/230	185/185/230	185/185/230	230/230/230
Oil Charge, Ckt.-1/Ckt.-2, gal.	5/5/4	5/5/5	5/5/5	5/5/5	5/5/5
Glycol Charge (43% concentration), gal	5.5	5.7	6.0	6.0	6.3
<b>Comp.s, Semihermetic Screw</b>					
Quantity per Chiller	3	3	3	3	3
<b>Condensers, High Efficiency Fin/Tube with Integral Subcooler</b>					
Total Chiller Coil Face Area, ft <sup>2</sup>	411	469	469	469	528
Number of Rows	3	3	3	3	3
Fins per Inch	17	17	17	17	17
<b>Condenser Fans</b>					
Number, Ckt.-1/Ckt.-2	5/5/4	5/5/6	5/5/6	5/5/6	6/6/6
<b>Low Noise Fans</b>					
Fan Motor, HP/kWi	2/1.8	2/1.8	2/1.8	2/1.8	2/1.8
Total Chiller Airflow, cfm	182000	208000	208000	208000	234000
<b>Ultra Quiet Fans</b>					
Fan Motor, HP/kWi	2/1.50	2/1.50	2/1.50	2/1.50	2/1.50
Total Chiller Airflow, cfm	182000	208000	208000	208000	234000
<b>Dual Speed Fans - Normal Speed</b>					
Fan Motor, hp	2	2	2	2	2
Total Chiller, CFM	154000	176000	176000	176000	198000
<b>Dual Speed Fans - Lower Speed</b>					
Fan Motor, hp	2	2	2	2	2
Total Chiller, CFM	117600	134400	134400	134400	151200
<b>High Static Fans</b>					
Fan Motor, hp	5	5	5	5	5
Total Chiller, CFM	195000	247000	247000	247000	273000
<b>Evaporator, Direct Expansion</b>					
Water Volume, gals.	202.0	202.0	236.0	236.0	236.0
Maximum Water Side Pressure, PSIG	150	150	150	150	150
Maximum Refrigerant Side Pressure, PSIG	235	235	235	235	235
Minimum Chilled Water Flow Rate, gpm	250	250	300	300	300
Maximum Chilled Water Flow Rate, gpm	1200	1200	1200	1200	1200
Water Connections, inches	10	10	10	10	10

**PHYSICAL DATA (SI - STANDARD EFFICIENCY)**

Refrigerant R-134a	STANDARD EFFICIENCY							
	MODEL NUMBER (YCIV ___ S/P)							
	50Hz	0600	0650	0720	0770	0840	0920	1000
<b>General Unit Data</b>								
Number of Independent Refrigerant Circuits	2	2	2	2	2	2	2	2
Refrigerant Charge, R-134a, Ckt.-1/Ckt.-2, kg.	74/74	77/77	84/77	87/80	87/87	105/89	105/105	
Oil Charge, Ckt.-1/Ckt.-2, liters	19/19	19/19	19/19	19/19	19/19	19/19	19/19	19/19
Compressors, Semihermetic Screw Qty per Chiller	2	2	2	2	2	2	2	2
<b>Condensers, High Efficiency Fin/Tube with Integral Subcooler</b>								
Total Chiller Coil Face Area, m2	21.8	21.8	24.5	24.5	27.2	30.0	32.7	
Number of Rows	3	3	3	3	3	3	3	3
Fins per meter	669	669	669	669	669	669	669	669
<b>Condenser Fans</b>								
Number, Ckt.-1/Ckt.-2	4/4	4/4	5/4	5/4	5/5	6/5	6/6	
<b>Low Noise Fans</b>								
Fan Motor, HP/kWi	2/1.50	2/1.50	2/1.50	2/1.50	2/1.50	2/1.50	2/1.50	2/1.50
Total Chiller Airflow, l/sec.	49082	49082	55218	55218	61353	67488	73624	
<b>Ultra Quiet Fans</b>								
Fan Motor, HP/kWi	2/1.50	2/1.50	2/1.50	2/1.50	2/1.50	2/1.50	2/1.50	2/1.50
Total Chiller Airflow, l/sec.	49082	49082	55218	55218	61353	67488	73624	
<b>Dual Speed Fans - Normal Speed</b>								
Fan, KWi	1.5	1.5	1.5	1.5	1.5	1.5	1.5	1.5
Total Chiller, m3/s	42	42	47	47	52	57	62	
<b>Dual Speed Fans - Lower Speed</b>								
Fan, KWi	1.5	1.5	1.5	1.5	1.5	1.5	1.5	1.5
Total Chiller, m3/s	32	32	36	36	40	44	48	
<b>High Static Fans</b>								
Fan, KWi	3.7	3.7	3.7	3.7	3.7	3.7	3.7	3.7
Total Chiller, m3/s	49	49	55	55	61	67	74	
<b>Evaporator, Direct Expansion</b>								
Water Volume, liters	253.6	359.6	359.6	529.9	529.9	529.9	529.9	529.9
Maximum Water Side Pressure, Bar	10	10	10	10	10	10	10	10
Maximum Refrigerant Side Pressure, Bar	16	16	16	16	16	16	16	16
Minimum Chilled Water Flow Rate, l/sec.	8.8	10.1	10.1	11.4	11.4	11.4	11.4	11.4
Maximum Chilled Water Flow Rate, l/sec.	42.6	47.3	47.3	50.5	50.5	50.5	50.5	50.5
Water Connections, inches	8	10	10	10	10	10	10	10

## PHYSICAL DATA (SI - STANDARD EFFICIENCY) (CONT'D)

<b>Refrigerant R-134a</b>	<b>STANDARD EFFICIENCY</b>				
	<b>MODEL NUMBER (YCIV ___ S/P)</b>				
<b>General Unit Data</b>	<b>50Hz</b>	<b>1070</b>	<b>1180</b>	<b>1340</b>	<b>1500</b>
Number of Independent Refrigerant Circuits	3	3	3	3	3
Refrigerant Charge, R-134a, Ckt.-1/Ckt.-2, kg.	84 / 77 / 77	84 / 84 / 77	84 / 84 / 105	105 / 105 / 105	105 / 105 / 105
Oil Charge, Ckt.-1/Ckt.-2, liters	19 / 15 / 15	19 / 19 / 15	19 / 19 / 19	19 / 19 / 19	19 / 19 / 19
Glycol Charge (43% concentration), liters	0	0	0	0	0
<b>Compressors, Semihermetic Screw</b>					
Quantity per Chiller	3	3	3	3	3
<b>Condensers, High Efficiency Fin/Tube with Integral Subcooler</b>					
Total Chiller Coil Face Area, m <sup>2</sup>	35	38	44	49	49
Number of Rows	3	3	3	3	3
Fins per meter	669	669	669	669	669
<b>Condenser Fans</b>					
Number, Ckt.-1/Ckt.-2	5/4/4	5/5/4	5/5/6	6/6/6	6/6/6
<b>Low Noise Fans</b>					
Fan Motor, HP/kWi	2/1.50	2/1.50	2/1.50	2/1.50	2/1.50
Total Chiller Airflow, l/sec.	79768	85904	98176	110448	110448
<b>Ultra Quiet Fans</b>					
Fan Motor, HP/kWi	2/1.50	2/1.50	2/1.50	2/1.50	2/1.50
Total Chiller Airflow, l/sec.	79768	85904	98176	110448	110448
<b>Dual Speed Fans - Normal Speed</b>					
Fan, KWi	1.5	1.5	1.5	1.5	1.5
Total Chiller, m3/s	67	67	78	78	78
<b>Dual Speed Fans - Lower Speed</b>					
Fan, KWi	1.5	1.5	1.5	1.5	1.5
Total Chiller, m3/s	52	52	59	59	59
<b>High Static Fans</b>					
Fan, KWi	3.7	3.7	3.7	3.7	3.7
Total Chiller, m3/s	80	86	98	110	110
<b>Evaporator, Direct Expansion</b>					
Water Volume, liters	764.6	893.3	893.3	893.3	893.3
Maximum Water Side Pressure, Bar	10	10	10	10	10
Maximum Refrigerant Side Pressure, Bar	16	16	16	16	16
Minimum Chilled Water Flow Rate, l/sec.	16	19	19	19	19
Maximum Chilled Water Flow Rate, l/sec.	76	76	76	76	76
Water Connections, mm	245	245	245	245	245

**PHYSICAL DATA (SI - HIGH EFFICIENCY)**

Refrigerant R-134a	HIGH EFFICIENCY							
	MODEL NUMBER (YCIV ___ E/V)							
General Unit Data	50Hz	0590	0630	0700	0760	0800	0830	0930
Number of Independent Refrigerant Circuits	2	2	2	2	2	2	2	2
Refrigerant Charge, R-134a, Ckt.-1/Ckt.-2, kg.	77/77	84/77	84/84	87/87	102/87	102/102	105/105	
Oil Charge, Ckt.-1/Ckt.-2, liters	19/19	19/19	19/19	19/19	19/19	19/19	19/19	19/19
Compressors, Semihermetic Screw Qty per Chiller	2	2	2	2	2	2	2	2
<b>Condensers, High Efficiency Fin/Tube with Integral Subcooler</b>								
Total Chiller Coil Face Area, m2	21.8	24.5	27.2	27.2	30.0	32.7	32.7	
Number of Rows	3	3	3	3	3	3	3	3
Fins per meter	669	669	669	669	669	669	669	669
<b>Condenser Fans</b>								
Number, Ckt.-1/Ckt.-2	4/4	5/4	5/5	5/5	6/5	6/6	6/6	
<b>Low Sound Fans</b>								
Fan Motor, HP/kWi	2/1.50	2/1.50	2/1.50	2/1.50	2/1.50	2/1.50	2/1.50	2/1.50
Total Chiller Airflow, l/sec.	49082	55218	61353	61353	67488	73624	73624	
<b>Ultra Quiet Fans</b>								
Fan Motor, HP/kWi	2/1.50	2/1.50	2/1.50	2/1.50	2/1.50	2/1.50	2/1.50	2/1.50
Total Chiller Airflow, l/sec.	49082	55218	61353	61353	67488	73624	73624	
<b>Dual Speed Fans - Normal Speed</b>								
Fan, KWi	1.5	1.5	1.5	1.5	1.5	1.5	1.5	1.5
Total Chiller, m3/s	42	47	52	52	57	62	62	
<b>Dual Speed Fans - Lower Speed</b>								
Fan, KWi	1.5	1.5	1.5	1.5	1.5	1.5	1.5	1.5
Total Chiller, m3/s	32	36	40	40	44	48	48	
<b>High Static Fans</b>								
Fan, KWi	3.7	3.7	3.7	3.7	3.7	3.7	3.7	3.7
Total Chiller, m3/s	49	55	61	61	67	74	74	
<b>Evaporator, Direct Expansion</b>								
Water Volume, liters	359.6	359.6	359.6	416.4	416.4	416.4	529.9	
Maximum Water Side Pressure, Bar <sup>1</sup>	10	10	10	10	10	10	10	10
Maximum Refrigerant Side Pressure, Bar	16	16	16	16	16	16	16	16
Minimum Chilled Water Flow Rate, l/sec.	10.1	10.1	10.1	11.4	11.4	11.4	11.4	11.4
Maximum Chilled Water Flow Rate, l/sec.	47.3	47.3	47.3	47.3	47.3	47.3	47.3	50.5
Water Connections, inches	10	10	10	10	10	10	10	10

## PHYSICAL DATA (SI - HIGH EFFICIENCY) (CONT'D)

<b>Refrigerant R-134a</b>	HIGH EFFICIENCY				
	MODEL NUMBER (YCIV ___ E/V)				
<b>General Unit Data</b>	<b>50Hz</b>	<b>1050</b>	<b>1120</b>	<b>1220</b>	<b>1380</b>
Number of Independent Refrigerant Circuits	3	3	3	3	3
Refrigerant Charge, R-134a, Ckt.-1/Ckt.-2, kg.	84 / 84 / 77	84 / 84 / 105	84 / 84 / 105	84 / 84 / 105	105 / 105 / 105
Oil Charge, Ckt.-1/Ckt.-2, liters	19 / 19 / 15	19 / 19 / 19	19 / 19 / 19	19 / 19 / 19	19 / 19 / 19
Glycol Charge (43% concentration), liters	0	0	0	0	0
<b>Compressors, Semihermetic Screw</b>					
Quantity per Chiller	3	3	3	3	3
<b>Condensers, High Efficiency Fin/Tube with Integral Subcooler</b>					
Total Chiller Coil Face Area, m <sup>2</sup>	38	44	44	44	49
Number of Rows	3	3	3	3	3
Fins per meter	669	669	669	669	669
<b>Condenser Fans</b>					
Number, Ckt.-1/Ckt.-2	05/05/04	05/05/06	05/05/06	05/05/06	06/06/06
<b>Low Noise Fans</b>					
Fan Motor, HP/kWi	2/1.50	2/1.50	2/1.50	2/1.50	2/1.50
Total Chiller Airflow, l/sec.	85904	98176	98176	98176	110448
<b>Ultra Quiet Fans</b>					
Fan Motor, HP/kWi	2/1.50	2/1.50	2/1.50	2/1.50	2/1.50
Total Chiller Airflow, l/sec.	85904	98176	98176	98176	110448
<b>Dual Speed Fans - Normal Speed</b>					
Fan, KWi	1.5	1.5	1.5	1.5	1.5
Total Chiller, m3/s	73	83	83	83	93
<b>Dual Speed Fans - Lower Speed</b>					
Fan, KWi	1.5	1.5	1.5	1.5	1.5
Total Chiller, m3/s	56	63	63	63	71
<b>High Static Fans</b>					
Fan, KWi	3.7	3.7	3.7	3.7	3.7
Total Chiller, m3/s	92	117	117	117	129
<b>Evaporator, Direct Expansion</b>					
Water Volume, liters	764.6	764.6	893.3	893.3	893.3
Maximum Water Side Pressure, Bar	10	10	10	10	10
Maximum Refrigerant Side Pressure, Bar	16	16	16	16	16
Minimum Chilled Water Flow Rate, l/sec.	16	16	19	19	19
Maximum Chilled Water Flow Rate, l/sec.	76	76	76	76	76
Water Connections, mm	245	245	245	245	245

## ELECTRICAL DATA

### 2 Compressor Power Wiring Connections

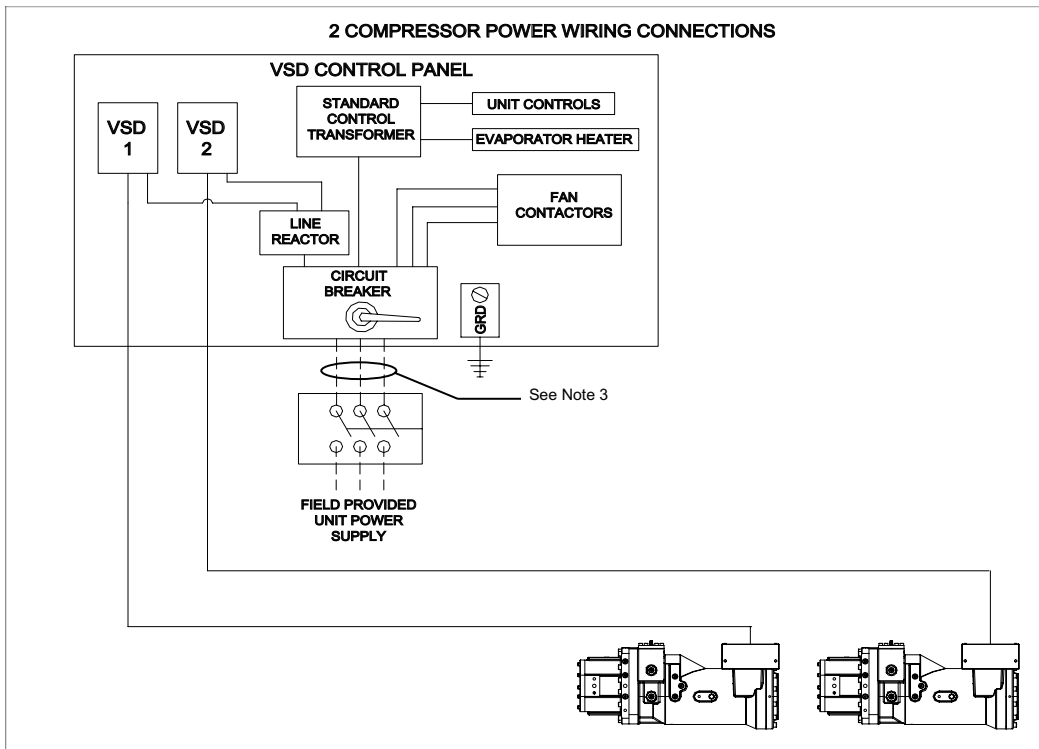

**FIG. 6 - TWO COMPRESSOR WIRING DIAGRAM WITH CIRCUIT BREAKER**

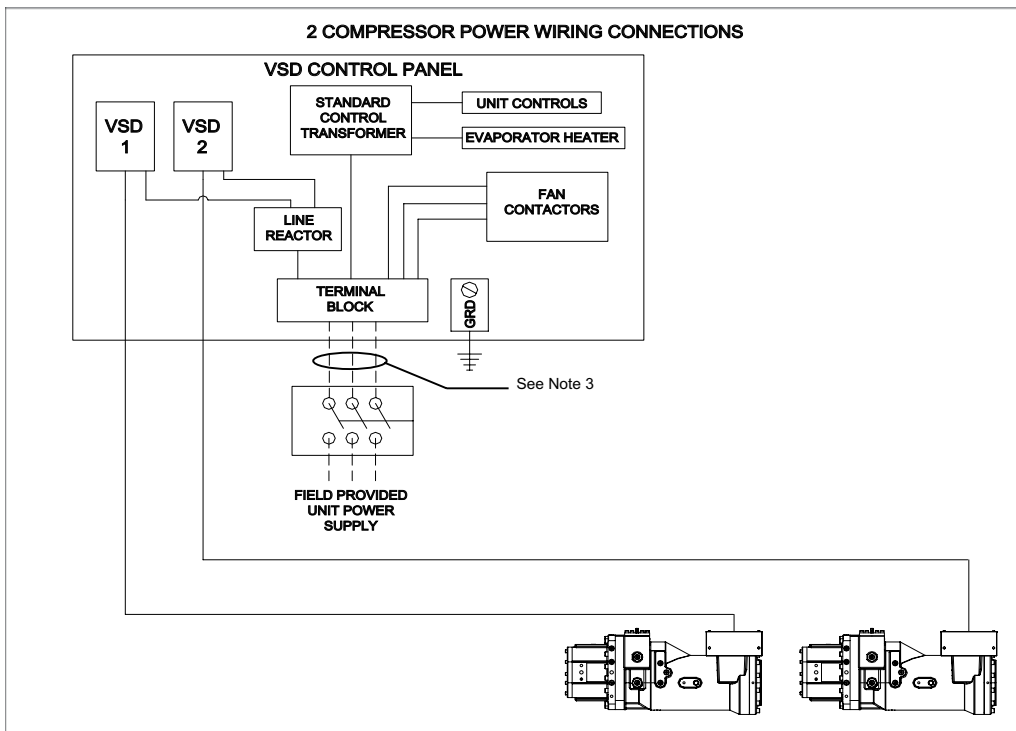
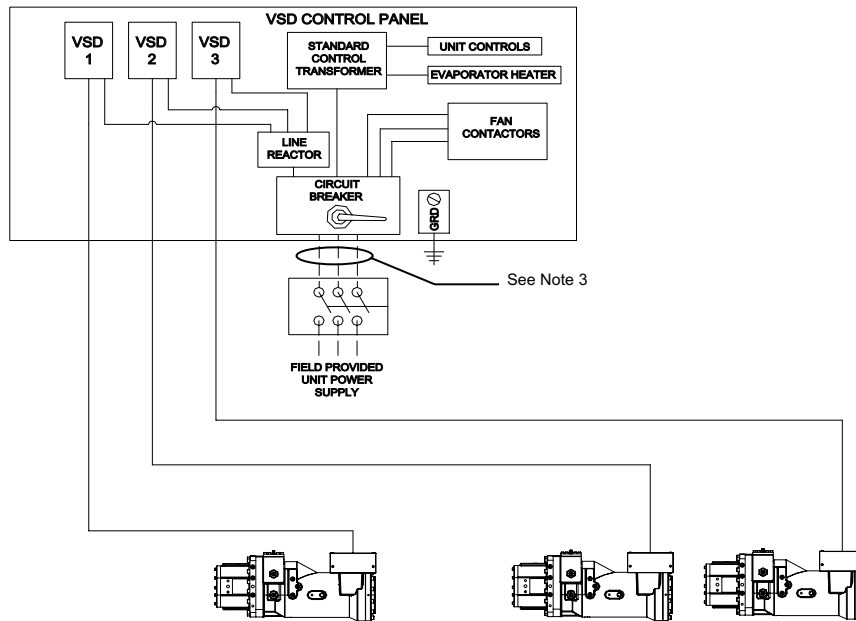

**FIG. 7 - TWO COMPRESSOR WIRING DIAGRAM WITH TERMINAL BLOCK**

# ELECTRICAL DATA (CONT'D)

## 3 Compressor Power Wiring Connections

3 COMPRESSOR POWER WIRING CONNECTIONS



**FIG. 8 - THREE COMPRESSOR WIRING DIAGRAM WITH CIRCUIT BREAKER – SINGLE POINT**

3 COMPRESSOR POWER WIRING CONNECTIONS

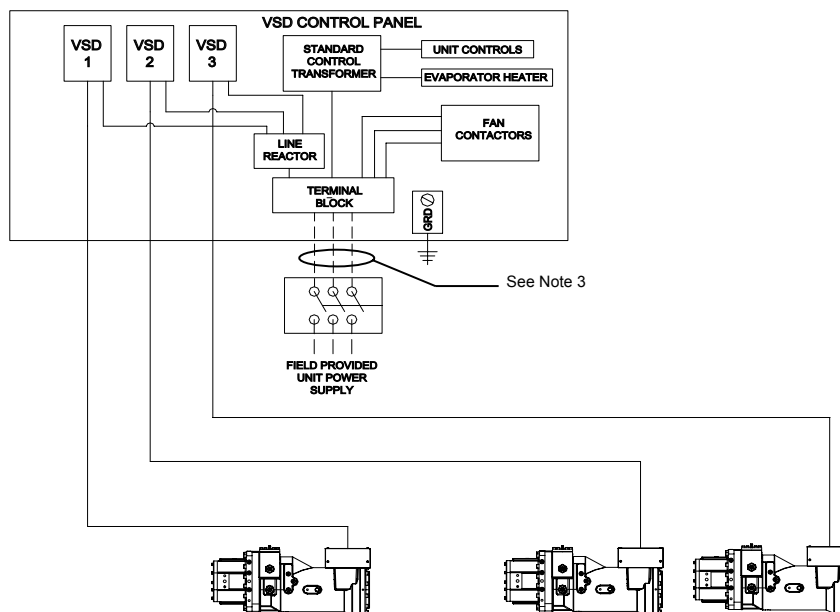

**FIG. 9 - THREE COMPRESSOR WIRING DIAGRAM WITH TERMINAL BLOCK – SINGLE POINT**

## STANDARD EFFICIENCY 2-Compressor Units (See FIG. 6)

One Field Provided Power Supply Circuit. Field Connections to Factory provided Terminal Block (Standard); or Individual System Breakers (Optional).

Standard Efficiency YCIV_ ___ S/P											
Model No./Nameplate			System 1								
			Std. & Ultra Quiet Cond. Fans			High Head/Static Cond. Fans			Two-Speed Cond. Fans		
YCIV S/P	Input Volts (9)	Input Freq	Compressor RLA (5)	Condenser Fans		Compressor RLA (5)	Condenser Fans		Compressor RLA (5)	Condenser Fans	
				Qty.	FLA (EA)		Qty.	FLA (EA)		Qty.	FLA (EA)
0600	400	50	144	4	3.1	144	4	9.3	152	4	3.8
0650	400	50	191	4	3.1	191	4	9.3	198	4	3.8
0720	400	50	195	5	3.1	195	5	9.3	207	5	3.8
0770	400	50	174	5	3.1	174	5	9.3	185	5	3.8
0840	400	50	194	5	3.1	194	5	9.3	206	5	3.8
0920	400	50	232	6	3.1	232	6	9.3	246	6	3.8
1000	400	50	230	6	3.1	230	6	9.3	243	6	3.8

YCIV S/P	Control KVA (7)	Unit Short Circuit Withstand (KA)		Field Wiring & Protection			
		Terminal Block (STD)	Circuit Breaker (OPT)	Std. & Ultra Quiet Cond. Fans			
				Minimum Ckt. Ampacity (MCA) (3)	Recommended Fuse/Ckt. Breaker Rating (4)	Max. Inverse Time Ckt. Brkr. Rating (2)	Max Dual Element Fuse Size (2)
0600	1.8	30KA	65KA	350	400	450	450
0650	1.8	30KA	65KA	390	450	500	500
0720	1.8	30KA	65KA	416	500	600	600
0770	1.8	30KA	65KA	446	500	600	600
0840	1.8	30KA	65KA	468	600	600	600
0920	1.8	30KA	65KA	517	600	700	700
1000	1.8	30KA	65KA	555	700	700	700

See page 92 for Electrical Data footnotes.

## STANDARD EFFICIENCY 2-Compressor Units (CONT'D)

One Field Provided Power Supply Circuit. Field Connections to Factory provided Terminal Block (Standard); or Individual System Breakers (Optional).

Standard Efficiency YCIV____ S/P								
System 2								
Std. & Ultra Quiet Cond. Fans			High Head/Static Cond. Fans			Two-Speed Cond. Fans		
Compressor RLA (5)	Condenser Fans		Compressor RLA (5)	Condenser Fans		Compressor RLA (5)	Condenser Fans	
	Qty.	FLA (EA)		Qty.	FLA (EA)		Qty.	FLA (EA)
144	4	3.1	144	4	9.3	152	4	3.8
127	4	3.1	127	4	9.3	132	4	3.8
144	4	3.1	144	4	9.3	152	4	3.8
195	4	3.1	195	4	9.3	201	4	3.8
194	5	3.1	194	5	9.3	206	5	3.8
192	5	3.1	192	5	9.3	204	5	3.8
230	6	3.1	230	6	9.3	243	6	3.8

6

High Head/High Static Fans				Two-Speed Cond. Fans			
Minimum Ckt. Ampacity (MCA) (3)	Recommended Fuse/Ckt. Breaker Rating (4)	Max. Inverse Time Ckt. Brkr. Rating (2)	Max Dual Element Fuse Size (2)	Minimum Ckt. Ampacity (MCA) (3)	Recommended Fuse/Ckt. Breaker Rating (4)	Max. Inverse Time Ckt. Brkr. Rating (2)	Max Dual Ele- ment Fuse Size (2)
373	450	500	500	399	450	500	500
410	500	600	600	440	500	600	600
445	500	600	600	472	600	600	600
471	600	600	600	502	600	700	700
502	600	700	700	530	600	700	700
553	700	800	800	585	700	800	800
593	700	800	800	629	700	800	800

**STANDARD EFFICIENCY 2-Compressor Units (CONT'D)**

STANDARD EFFICIENCY YCIV____S/P										
MODEL NO./NAMEPLATE			FIELD WIRING LUGS							
YCIV S/P	INPUT VOLTS (9)	INPUT FREQ	STD TERMINAL BLOCK STD., U.Q. & TWO- SPD COND. FANS		OPT CIRCUIT BREAKER STD., U.Q. & 2-SPD COND. FANS		STD TERMINAL BLOCK HIGH HEAD/HIGH STATIC COND. FANS		OPT CIRCUIT BREAKER HIGH HEAD/HIGH STATIC COND. FANS	
			LUGS/ PHASE (1)	LUG WIRE RANGE	LUGS/ PHASE (1)	LUG WIRE RANGE	LUGS/ PHASE (1)	LUG WIRE RANGE	LUGS/ PHASE (1)	LUG WIRE RANGE
0600	400	50	2	#2 - 600 KCM	2	#2/0 - 500 KCM	3	#2 - 600 KCM	3	#2 - 600 KCM
0650	400	50	2	#2 - 600 KCM	2	#2/0 - 500 KCM	3	#2 - 600 KCM	3	#2 - 600 KCM
0720	400	50	2	#2 - 600 KCM	2	#2/0 - 500 KCM	3	#2 - 600 KCM	3	#2 - 600 KCM
0770	400	50	2	#2 - 600 KCM	2	#2/0 - 500 KCM	3	#2 - 600 KCM	3	#2 - 600 KCM
0840	400	50	2	#2 - 600 KCM	2	#2/0 - 500 KCM	3	#2 - 600 KCM	3	#2 - 600 KCM
0920	400	50	2	#2 - 600 KCM	2	#3/0 - 400 KCM	3	#2 - 600 KCM	3	#2 - 600 KCM
1000	400	50	3	#2 - 600 KCM	3	#3/0 - 400 KCM	3	#2 - 600 KCM	3	#3/0 - 400 KCM

**THIS PAGE INTENTIONALLY LEFT BLANK**

## HIGH EFFICIENCY 2-Compressor Units (See FIG. 7)

One Field Provided Power Supply Circuit. Field Connections to Factory provided Terminal Block (Standard); or Individual System Breakers (Optional).

High Efficiency YCIV____E/V											
Model No./Nameplate			System 1								
			Std. & Ultra Quiet Cond. Fans			High Head/Static Cond. Fans			Two-Speed Cond. Fans		
YCIV E/V	Input Volts (9)	Input Freq	Compressor RLA (5)	Condenser Fans		Compressor RLA (5)	Condenser Fans		Compressor RLA (5)	Condenser Fans	
				Qty	FLA (EA)		Qty.	FLA (EA)		Qty.	FLA (EA)
0590	400	50	132	4	3.1	132	4	9.3	138	4	3.8
0630	400	50	134	5	3.1	134	5	9.3	139	5	3.8
0700	400	50	185	5	3.1	185	5	9.3	196	5	3.8
0760	400	50	170	5	3.1	170	5	9.3	180	5	3.8
0800	400	50	170	6	3.1	170	6	9.3	178	6	3.8
0830	400	50	180	6	3.1	180	6	9.3	189	6	3.8
0930	400	50	233	6	3.1	233	6	9.3	246	6	3.8

YCIV E/V	Control KVA (7)	Unit Short Circuit Withstand (KA)		Field Wiring & Protection			
		Terminal Block (STD)	Circuit Breaker (OPT)	Std. & Ultra Quiet Cond. Fans			
				Minimum Ckt. Ampacity (MCA) (3)	Recommended Fuse/Ckt. Breaker Rating (4)	Max. Inverse Time Ckt. Brkr. Rating (2)	Max Dual Element Fuse Size (2)
0590	1.8	30KA	65KA	322	400	450	450
0630	1.8	30KA	65KA	344	400	450	450
0700	1.8	30KA	65KA	388	450	500	500
0760	1.8	30KA	65KA	412	500	500	500
0800	1.8	30KA	65KA	433	500	600	600
0830	1.8	30KA	65KA	443	500	600	600
0930	1.8	30KA	65KA	506	600	700	700

See page 92 for Electrical Data footnotes.

## HIGH EFFICIENCY 2-Compressor Units (CONT'D)

One Field Provided Power Supply Circuit. Field Connections to Factory provided Terminal Block (Standard); or Individual System Breakers (Optional).

High Efficiency YCIV____E/V								
System 2								
Std. & Ultra Quiet Cond. Fans			High Head/Static Cond. Fans			Two-Speed Cond. Fans		
Compressor RLA (5)	Condenser Fans		Compressor RLA (5)	Condenser Fans		Compressor RLA (5)	Condenser Fans	
	Qty.	FLA (EA)		Qty.	FLA (EA)		Qty.	FLA (EA)
132	4	3.1	132	4	9.3	138	4	3.8
146	4	3.1	146	4	9.3	154	4	3.8
126	5	3.1	126	5	9.3	131	5	3.8
170	5	3.1	170	5	9.3	180	5	3.8
183	5	3.1	183	5	9.3	195	5	3.8
180	6	3.1	180	6	9.3	189	6	3.8
178	6	3.1	178	6	9.3	187	6	3.8

Field Wiring & Protection							
High Head/High Static Fans				Two-Speed Cond. Fans			
Minimum Ckt. Ampacity (MCA) (3)	Recommended Fuse/Ckt. Breaker Rating (4)	Max. Inverse Time Ckt. Brkr. Rating (2)	Max Dual Element Fuse Size (2)	Minimum Ckt. Ampacity (MCA) (3)	Recommended Fuse/Ckt. Breaker Rating (4)	Max. Inverse Time Ckt. Brkr. Rating (2)	Max Dual Element Fuse Size (2)
372	450	500	500	342	400	450	450
400	450	500	500	366	450	500	500
450	500	600	600	414	500	600	600
474	600	600	600	442	500	600	600
501	600	600	600	463	600	600	600
517	600	700	700	472	600	600	600
581	700	800	800	541	700	700	700

**HIGH EFFICIENCY 2-Compressor Units (CONT'D)**

HIGH EFFICIENCY YCIV___E/V										
MODEL NO./NAMEPLATE			FIELD WIRING LUGS							
YCIV E/V	INPUT VOLTS (9)	INPUT FREQ	STD TERMINAL BLOCK STD., U.Q. & TWO- SPD COND. FANS		OPT CIRCUIT BREAKER STD., U.Q. & 2-SPD COND. FANS		STD TERMINAL BLOCK HIGH HEAD/HIGH STATIC COND. FANS		OPT CIRCUIT BREAKER HIGH HEAD/HIGH STATIC COND. FANS	
			LUGS/ PHASE (1)	LUG WIRE RANGE	LUGS/ PHASE (1)	LUG WIRE RANGE	LUGS/ PHASE (1)	LUG WIRE RANGE	LUGS/ PHASE (1)	LUG WIRE RANGE
0590	400	50	2	#2 - 600 KCM	2	#2/0 - 500 KCM	3	#2 - 600 KCM	3	#2 - 600 KCM
0630	400	50	2	#2 - 600 KCM	2	#2/0 - 500 KCM	3	#2 - 600 KCM	3	#2 - 600 KCM
0700	400	50	2	#2 - 600 KCM	2	#2/0 - 500 KCM	3	#2 - 600 KCM	3	#2 - 600 KCM
0760	400	50	2	#2 - 600 KCM	2	#2/0 - 500 KCM	3	#2 - 600 KCM	3	#2 - 600 KCM
0800	400	50	2	#2 - 600 KCM	2	#2/0 - 500 KCM	3	#2 - 600 KCM	3	#2 - 600 KCM
0830	400	50	2	#2 - 600 KCM	2	#2/0 - 500 KCM	3	#2 - 600 KCM	3	#2 - 600 KCM
0930	400	50	3	#2 - 600 KCM	3	#3/0 - 400 KCM	3	#2 - 600 KCM	3	#3/0 - 400 KCM

**THIS PAGE INTENTIONALLY LEFT BLANK**

## STANDARD EFFICIENCY 3-Compressor Units (See FIG. 8)

One Field Provided Power Supply Circuit. Field Connections to Factory provided Terminal Block (Standard); or Individual System Breakers (Optional).

Model No./Nameplate			System 1									System 2		
			Std. & Ultra Quiet Cond. Fans			High Head/Static Cond. Fans			Two-Speed Cond. Fans			Std. & Ultra Quiet Cond. Fans		
YCIV S/P	Input Volts (9)	Input Freq	Comp.		Condenser Fans		Comp.		Condenser Fans		Comp.		Condenser Fans	
			RLA (5)	Qty.	FLA (EA)	RLA (5)	Qty.	FLA (EA)	RLA (5)	Qty.	FLA (EA)	RLA (5)	Qty.	FLA (EA)
1070	400	50	175	5	3.1	175	5	9.3	186	5	3.8	196	4	3.1
1180	400	50	177	5	3.1	177	5	9.3	188	5	3.8	177	5	3.1
1340	400	50	192	5	3.1	192	5	9.3	204	5	3.8	192	5	3.1
1500	400	50	229	6	3.1	229	6	9.3	243	6	3.8	229	6	3.1

YCIV S/P	Control KVA (7)	Unit Short Circuit Withstand (KA)		Field Wiring & Protection					
				Std. & Ultra Quiet Cond. Fans				High Head/High Static Fans	
		Terminal Block (STD)	Circuit Breaker (OPT)	Minimum Ckt. Ampacity (MCA) (3)	Recommended Fuse/Ckt. Breaker Rating (4)	Max. Inverse Time Ckt. Brkr. Rating (2)	Max Dual Element Fuse Size (2)	Minimum Ckt. Ampacity (MCA) (3)	Recommended Fuse/Ckt. Breaker Rating (4)
1070	2.4	30KA	65KA	590	700	700	700	671	800
1180	2.4	30KA	65KA	644	700	800	800	731	800
1340	2.4	30KA	65KA	724	800	800	800	824	1000
1500	2.4	30KA	65KA	801	1000	1000	1000	913	1000

See page 92 for Electrical Data footnotes.

## STANDARD EFFICIENCY 3-Compressor Units (CONT'D)

(One Field Provided Power Supply Circuit. Field Connections to Factory provided Terminal Block (Standard); or Individual System Breakers (Optional).)

System 2						System 3								
High Head/Static Cond. Fans			Two-Speed Cond. Fans			Std. & Ultra Quiet Cond. Fans			High Head/Static Cond. Fans			Two-Speed Cond. Fans		
Comp.	Condenser Fans		Comp.	Condenser Fans		Comp.	Condenser Fans		Comp.	Condenser Fans		Comp.	Condenser Fans	
RLA (5)	Qty.	FLA (EA)	RLA (5)	Qty.	FLA (EA)	RLA (5)	Qty.	FLA (EA)	RLA (5)	Qty.	FLA (EA)	RLA (5)	Qty.	FLA (EA)
196	4	9.3	202	4	3.8	129	4	3.1	129	4	9.3	135	4	3.8
177	5	9.3	188	5	3.8	198	4	3.1	198	4	9.3	203	4	3.8
192	5	9.3	204	5	3.8	232	6	3.1	232	6	9.3	245	6	3.8
229	6	9.3	243	6	3.8	229	6	3.1	229	6	9.3	243	6	3.8

6

Field Wiring & Protection						Field Wiring Lugs			
High Head/High Static Fans		Two-Speed Cond. Fans				STD Terminal Block		OPT Circuit Breaker	
Max. Inverse Time Ckt. Brkr. Rating (2)	Max Dual Element Fuse Size (2)	Minimum Ckt. Ampacity (MCA) (3)	Recommended Fuse/Ckt. Breaker Rating (4)	Max. Inverse Time Ckt. Brkr. Rating (2)	Max Dual Element Fuse Size (2)	Lugs/Phase (1)	Lug Wire Range	Lugs/Phase (1)	Lug Wire Range
800	800	623	700	800	800	4	#2 - 600 KCM	4	#4/0 - 500 KCM
800	800	683	800	800	800	4	#2 - 600 KCM	4	#4/0 - 500 KCM
1000	1000	776	1000	1000	1000	4	#2 - 600 KCM	4	#4/0 - 500 KCM
1000	1000	857	1000	1000	1000	4	#2 - 600 KCM	4	#4/0 - 500 KCM

## HIGH EFFICIENCY 3-Compressor Units (See FIG. 9)

(One Field Provided Power Supply Circuit. Field Connections to Factory provided Terminal Block (Standard); or Individual System Breakers (Optional).)

Model No./Nameplate			System 1									System 2		
YCIV E/V	Input Volts (9)	Input Freq	Std. & Ultra Quiet Cond. Fans			High Head/Static Cond. Fans			Two-Speed Cond. Fans			Std. & Ultra Quiet Cond. Fans		
			Comp.	Condenser Fans		Comp.	Condenser Fans		Comp.	Condenser Fans		Comp.	Condenser Fans	
			RLA (5)	Qty.	FLA (EA)	RLA (5)	Qty.	FLA (EA)	RLA (5)	Qty.	FLA (EA)	RLA (5)	Qty.	FLA (EA)
1050	400	50	170	5	3.1	170	5	9.3	180	5	3.8	170	5	3.1
1120	400	50	164	5	3.1	164	5	9.3	173	5	3.8	164	5	3.1
1220	400	50	183	5	3.1	183	5	9.3	194	5	3.8	183	5	3.1
1380	400	50	218	6	3.1	218	6	9.3	229	6	3.8	218	6	3.1

YCIV E/V	Control KVA (7)	Unit Short Circuit Withstand (KA)		Field Wiring & Protection					
				Std. & Ultra Quiet Cond. Fans				High Head/High Static Fans	
		Terminal Block (STD)	Circuit Breaker (OPT)	Minimum Ckt. Ampacity (MCA) (3)	Recommended Fuse/Ckt. Breaker Rating (4)	Max. Inverse Time Ckt. Brkr. Rating (2)	Max Dual Element Fuse Size (2)	Minimum Ckt. Ampacity (MCA) (3)	Recommended Fuse/Ckt. Breaker Rating (4)
1050	2.4	30KA	65KA	552	600	700	700	639	700
1120	2.4	30KA	65KA	580	700	700	700	673	800
1220	2.4	30KA	65KA	631	700	800	800	730	800
1380	2.4	30KA	65KA	713	800	800	800	824	1000

See page 92 for Electrical Data footnotes.

## HIGH EFFICIENCY 3-Compressor Units (CONT'D)

(One Field Provided Power Supply Circuit. Field Connections to Factory provided Terminal Block (Standard); or Individual System Breakers (Optional).)

System 2						System 3								
High Head/Static Cond. Fans			Two-Speed Cond. Fans			Std. & Ultra Quiet Cond. Fans			High Head/Static Cond. Fans			Two-Speed Cond. Fans		
Comp.	Condenser Fans		Comp.	Condenser Fans		Comp.	Condenser Fans		Comp.	Condenser Fans		Comp.	Condenser Fans	
RLA (5)	Qty.	FLA (EA)	RLA (5)	Qty.	FLA (EA)	RLA (5)	Qty.	FLA (EA)	RLA (5)	Qty.	FLA (EA)	RLA (5)	Qty.	FLA (EA)
170	5	9.3	180	5	3.8	126	4	3.1	126	4	9.3	132	4	3.8
164	5	9.3	173	5	3.8	164	5	3.1	164	5	9.3	173	5	3.8
183	5	9.3	194	5	3.8	169	6	3.1	169	6	9.3	178	6	3.8
218	6	9.3	229	6	3.8	167	6	3.1	167	6	9.3	175	6	3.8

6

Field Wiring & Protection						Field Wiring Lugs			
High Head/High Static Fans		Two-Speed Cond. Fans				STD Terminal Block		OPT Circuit Breaker	
Max. Inverse Time Ckt. Brkr. Rating (2)	Max Dual Element Fuse Size (2)	Minimum Ckt. Ampacity (MCA) (3)	Recommended Fuse/Ckt. Breaker Rating (4)	Max. Inverse Time Ckt. Brkr. Rating (2)	Max Dual Element Fuse Size (2)	Lugs/Phase (1)	Lug Wire Range	Lugs/Phase (1)	Lug Wire Range
800	800	590	700	700	700	4	#2 - 600 KCM	4	#4/0 - 500 KCM
800	800	621	700	700	700	4	#2 - 600 KCM	4	#4/0 - 500 KCM
800	800	676	800	800	800	4	#2 - 600 KCM	4	#4/0 - 500 KCM
1000	1000	760	800	800	800	4	#2 - 600 KCM	4	#4/0 - 500 KCM

## ELECTRICAL NOTES

1. As standard, all units have single point power connection. Contact factory for information regarding dual point power units.
2. Maximum Inverse Time Circuit Breaker or Dual Element Fuse - 225% of the largest compressor RLA plus the sum of all the other loads per NEC 440.22 (A).
3. MCA - Minimum Circuit Ampacity - 125% of the largest compressor RLA plus 100% of the remaining compressor RLA's plus the sum of all condenser fan FLA's per NEC 440.33
4. Recommended time delay or dual element fuse size - 150% of the largest compressor RLA plus 100% of the remaining compressor RLA's plus the sum of all condenser fan FLA's.
5. RLA - Rated Load Amps - rated in accordance with UL standard 1995.
6. Local codes may take precedence.
7. Control KVA includes operational controls and evaporator heaters.
8. System inrush current is less than RLA due to the use of York Variable Speed Drive technology. Typical Compressor Starting Current (first four seconds of start-up):

Rated Voltage	Typical Starting Current per Compressor
380-400/50/3	28A
380/60/3	29A
460/60/3	23A

9. Voltage Utilization Range:

Rated Voltage	Utilization Range
380-415/50/3	360-440
380/60/3	342-402
460/60/3	414-508

**LEGEND:**

C.B.	CIRCUIT BREAKER
D.E.	DUAL ELEMENT FUSE
DISC SW	DISCONNECT SWITCH
FACT CB	FACTORY-MOUNTED CIRCUIT BREAKER
FLA	FULL LOAD AMPS
HZ	HERTZ
MAX	MAXIMUM
MCA	MINIMUM CIRCUIT AMPACITY
MIN	MINIMUM
MIN NF	MINIMUM NON-FUSED
RLA	RATED LOAD AMPS
S.P. WIRE	SINGLE-POINT WIRING

**NOTES:**

1. U.L. Label is provided on 60 Hz units for these electrical wiring configurations.
2. — — — — — Dashed Line = Field Provided Wiring.
3. The above recommendations are based on the National Electric Code and using copper conductors only. Field wiring must also comply with local codes. Group Rated breaker must be HACR type for cUL machines.

**THIS PAGE INTENTIONALLY LEFT BLANK**

ELECTRICAL WIRING DIAGRAMS - 2 COMPRESSOR MODELS

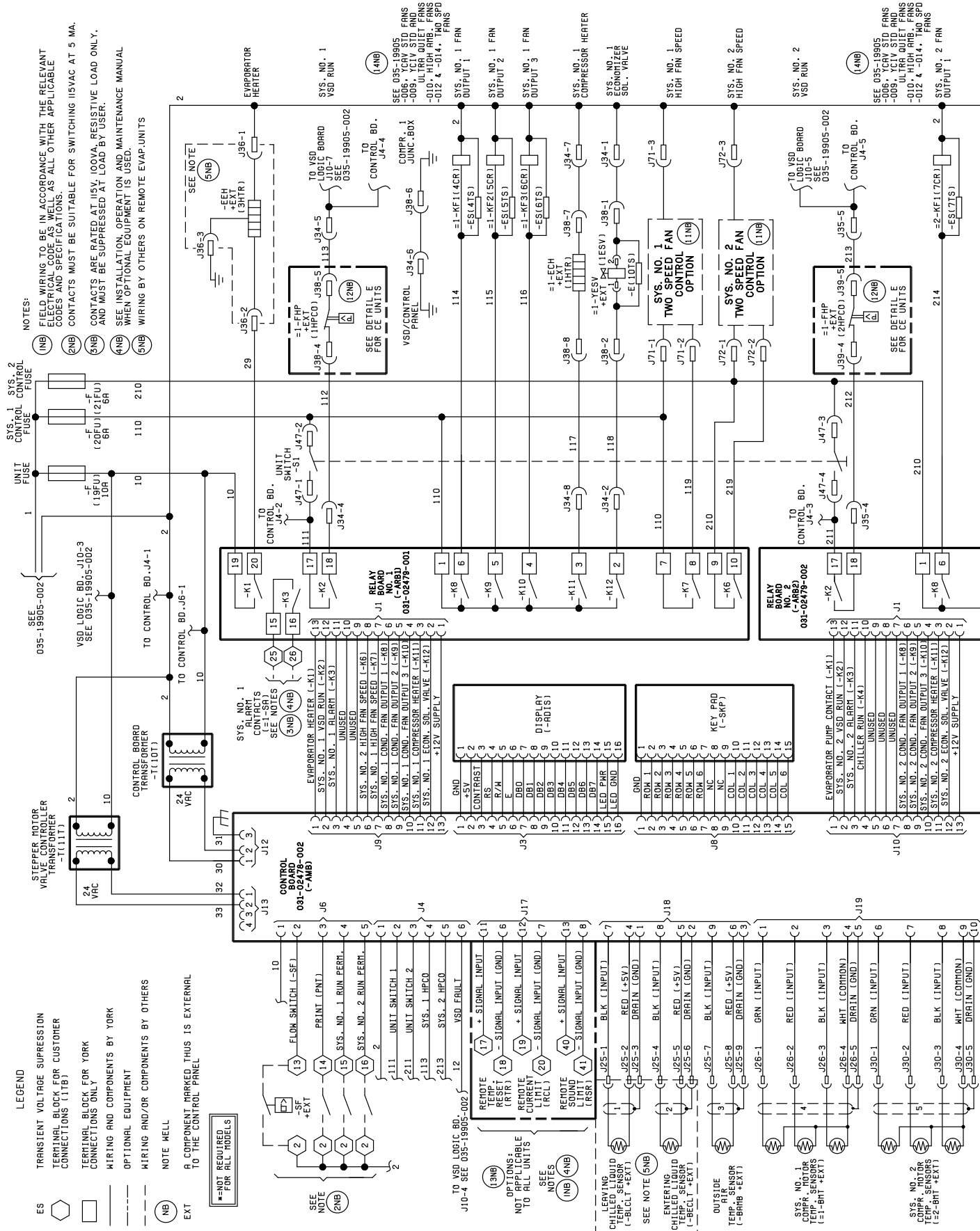
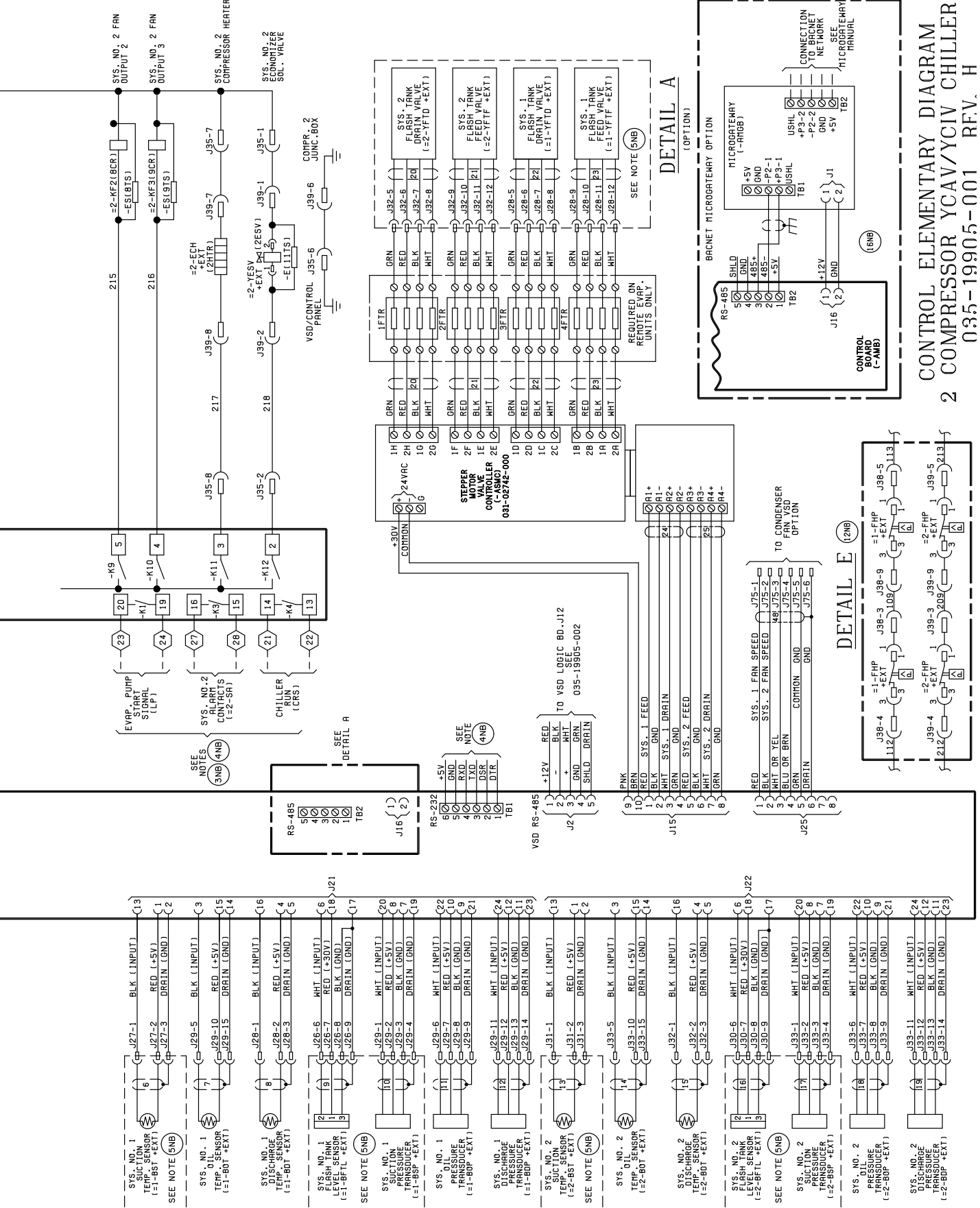

FIG. 10 - ELEMENTARY CONTROL WIRING DIAGRAM 2 COMPRESSOR MODELS

LD13071

CONTROL ELEMENTARY DIAGRAM  
2 COMPRESSOR YCAV/YCIV CHILLER  
035-19905-001 R.F.V. H



SEE NOTE 5NB

SEE NOTE 5NB

SEE NOTE 5NB

SEE NOTE 5NB

SEE NOTE 5NB

SEE NOTE 5NB

SEE NOTE 5NB

SEE NOTE 5NB

SEE NOTE 5NB

SEE NOTE 5NB

SEE NOTE 5NB

SEE NOTE 5NB

SEE NOTE 5NB

SEE NOTE 5NB

SEE NOTE 5NB

SEE NOTE 5NB

SEE NOTE 5NB

SEE NOTE 5NB

SEE NOTE 5NB

SEE NOTE 5NB

SEE NOTE 5NB

SEE NOTE 5NB

SEE NOTE 5NB

SEE NOTE 5NB

SEE NOTE 5NB

SEE NOTE 5NB

SEE NOTE 5NB

SEE NOTE 5NB

SEE NOTE 5NB

SEE NOTE 5NB

SEE NOTE 5NB

SEE NOTE 5NB

SEE NOTE 5NB

SEE NOTE 5NB

SEE NOTE 5NB

SEE NOTE 5NB

SEE NOTE 5NB

SEE NOTE 5NB

SEE NOTE 5NB

SEE NOTE 5NB

SEE NOTE 5NB

SEE NOTE 5NB

SEE NOTE 5NB

SEE NOTE 5NB

SEE NOTE 5NB

SEE NOTE 5NB

SEE NOTE 5NB

SEE NOTE 5NB

SEE NOTE 5NB

SEE NOTE 5NB

SEE NOTE 5NB

SEE NOTE 5NB

SEE NOTE 5NB

SEE NOTE 5NB

SEE NOTE 5NB

SEE NOTE 5NB

SEE NOTE 5NB

SEE NOTE 5NB

SEE NOTE 5NB

SEE NOTE 5NB

SEE NOTE 5NB

SEE NOTE 5NB

SEE NOTE 5NB

SEE NOTE 5NB

SEE NOTE 5NB

SEE NOTE 5NB

SEE NOTE 5NB

SEE NOTE 5NB

SEE NOTE 5NB

SEE NOTE 5NB

SEE NOTE 5NB

SEE NOTE 5NB

SEE NOTE 5NB

SEE NOTE 5NB

SEE NOTE 5NB

SEE NOTE 5NB

SEE NOTE 5NB

SEE NOTE 5NB

SEE NOTE 5NB

SEE NOTE 5NB

SEE NOTE 5NB

SEE NOTE 5NB

SEE NOTE 5NB

SEE NOTE 5NB

SEE NOTE 5NB

SEE NOTE 5NB

SEE NOTE 5NB

SEE NOTE 5NB

SEE NOTE 5NB

SEE NOTE 5NB

SEE NOTE 5NB

SEE NOTE 5NB

SEE NOTE 5NB

SEE NOTE 5NB

SEE NOTE 5NB

SEE NOTE 5NB

SEE NOTE 5NB

SEE NOTE 5NB

SEE NOTE 5NB

SEE NOTE 5NB

SEE NOTE 5NB

SEE NOTE 5NB

SEE NOTE 5NB

SEE NOTE 5NB

SEE NOTE 5NB

SEE NOTE 5NB

SEE NOTE 5NB

SEE NOTE 5NB

SEE NOTE 5NB

SEE NOTE 5NB

SEE NOTE 5NB

SEE NOTE 5NB

SEE NOTE 5NB

SEE NOTE 5NB

SEE NOTE 5NB

SEE NOTE 5NB

SEE NOTE 5NB

SEE NOTE 5NB

SEE NOTE 5NB

SEE NOTE 5NB

SEE NOTE 5NB

SEE NOTE 5NB

SEE NOTE 5NB

SEE NOTE 5NB

SEE NOTE 5NB

SEE NOTE 5NB

SEE NOTE 5NB

SEE NOTE 5NB

SEE NOTE 5NB

SEE NOTE 5NB

SEE NOTE 5NB

SEE NOTE 5NB

SEE NOTE 5NB

SEE NOTE 5NB

SEE NOTE 5NB

SEE NOTE 5NB

SEE NOTE 5NB

SEE NOTE 5NB

SEE NOTE 5NB

SEE NOTE 5NB

SEE NOTE 5NB

SEE NOTE 5NB

SEE NOTE 5NB

SEE NOTE 5NB

SEE NOTE 5NB

SEE NOTE 5NB

SEE NOTE 5NB

SEE NOTE 5NB

SEE NOTE 5NB

SEE NOTE 5NB

SEE NOTE 5NB

SEE NOTE 5NB

SEE NOTE 5NB

SEE NOTE 5NB

SEE NOTE 5NB

SEE NOTE 5NB

SEE NOTE 5NB

SEE NOTE 5NB

SEE NOTE 5NB

SEE NOTE 5NB

SEE NOTE 5NB

SEE NOTE 5NB

SEE NOTE 5NB

SEE NOTE 5NB

SEE NOTE 5NB

SEE NOTE 5NB

SEE NOTE 5NB

SEE NOTE 5NB

SEE NOTE 5NB

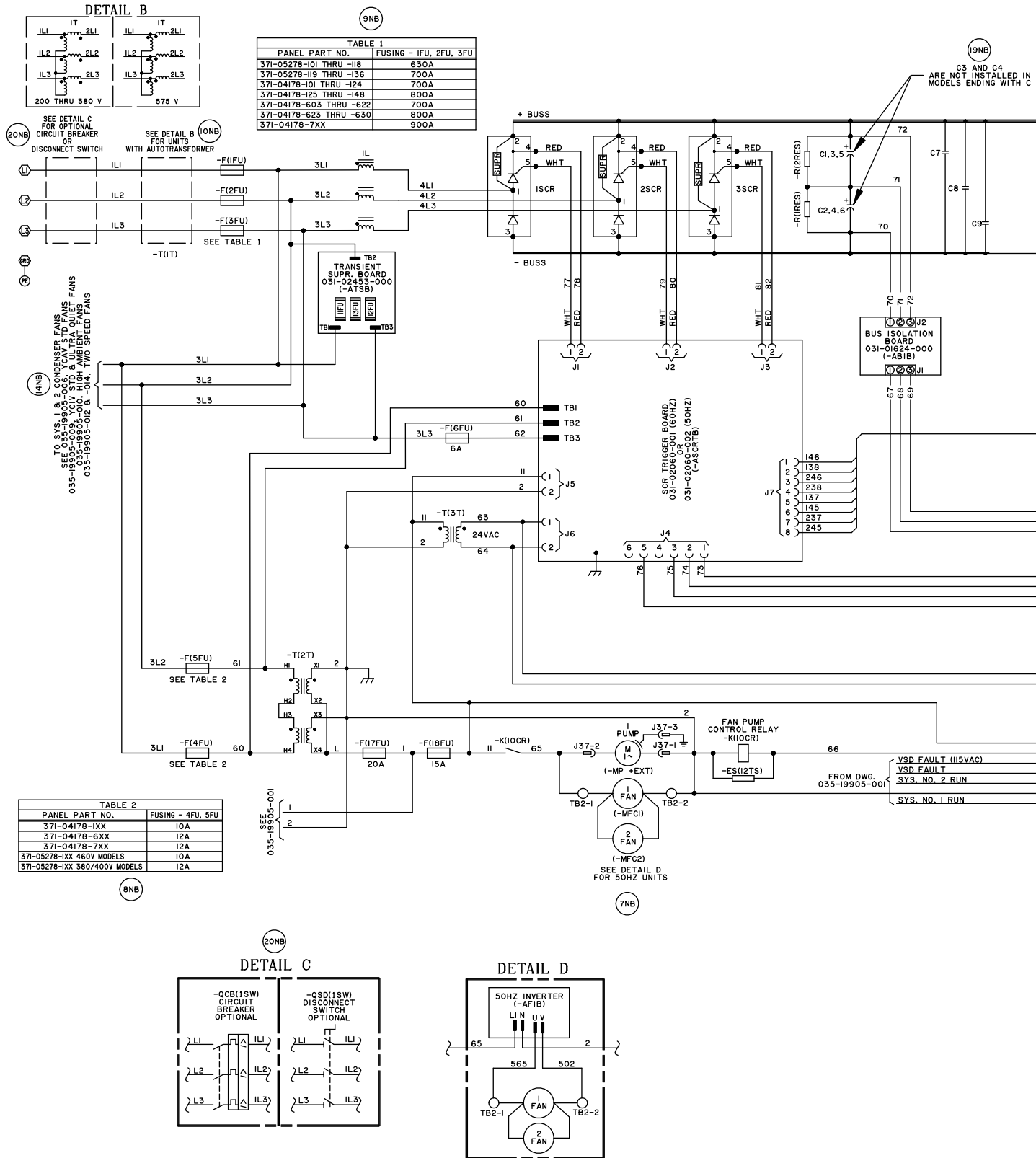
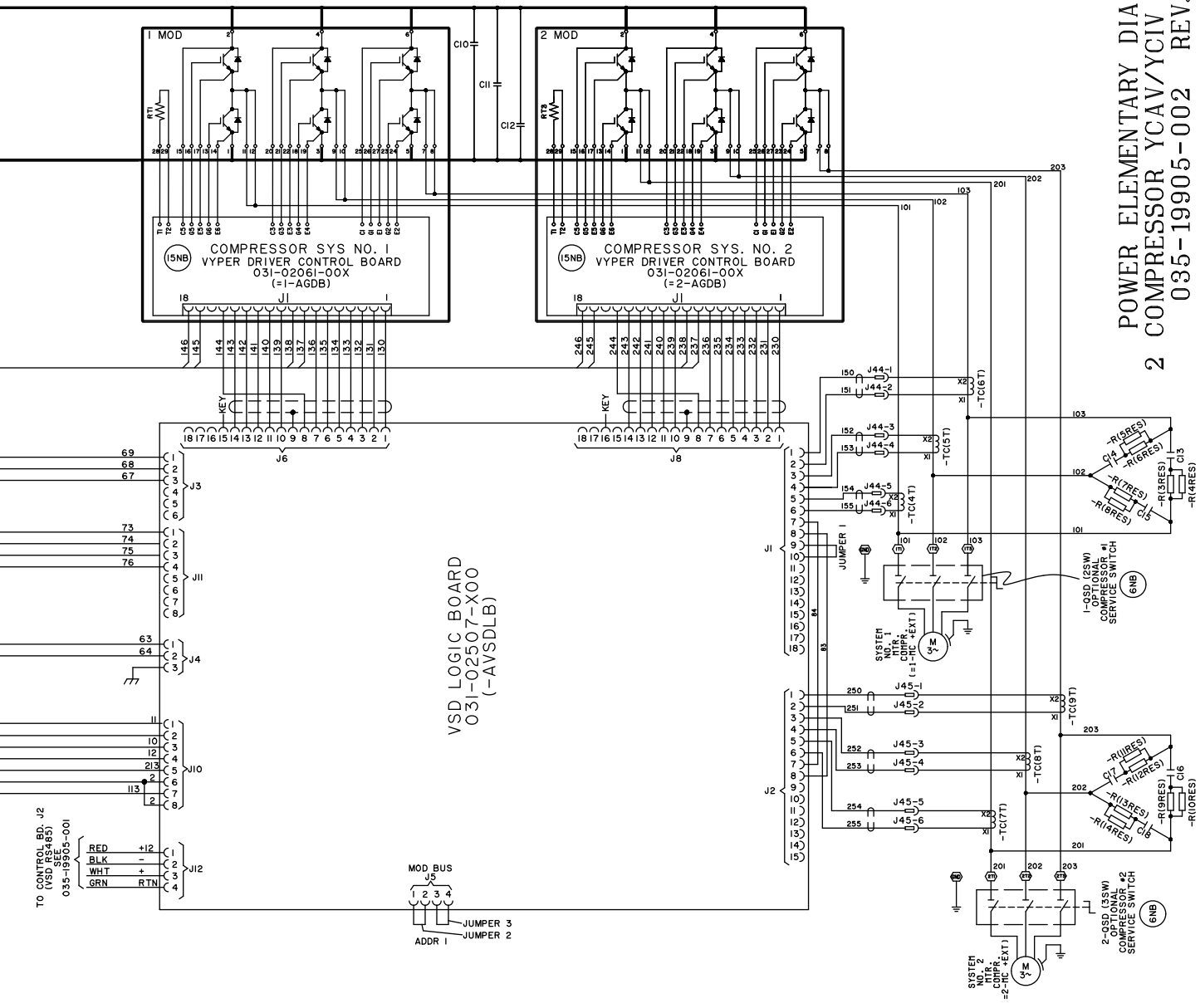

FIG. 11 - ELEMENTARY POWER WIRING DIAGRAM - YCIV0590-1000 2 COMPRESSOR MODELS

POWER ELEMENTARY DIAGRAM  
 2 COMPRESSOR YCAV/YCIV CHILLER  
 035-19905-002 REV. H

6



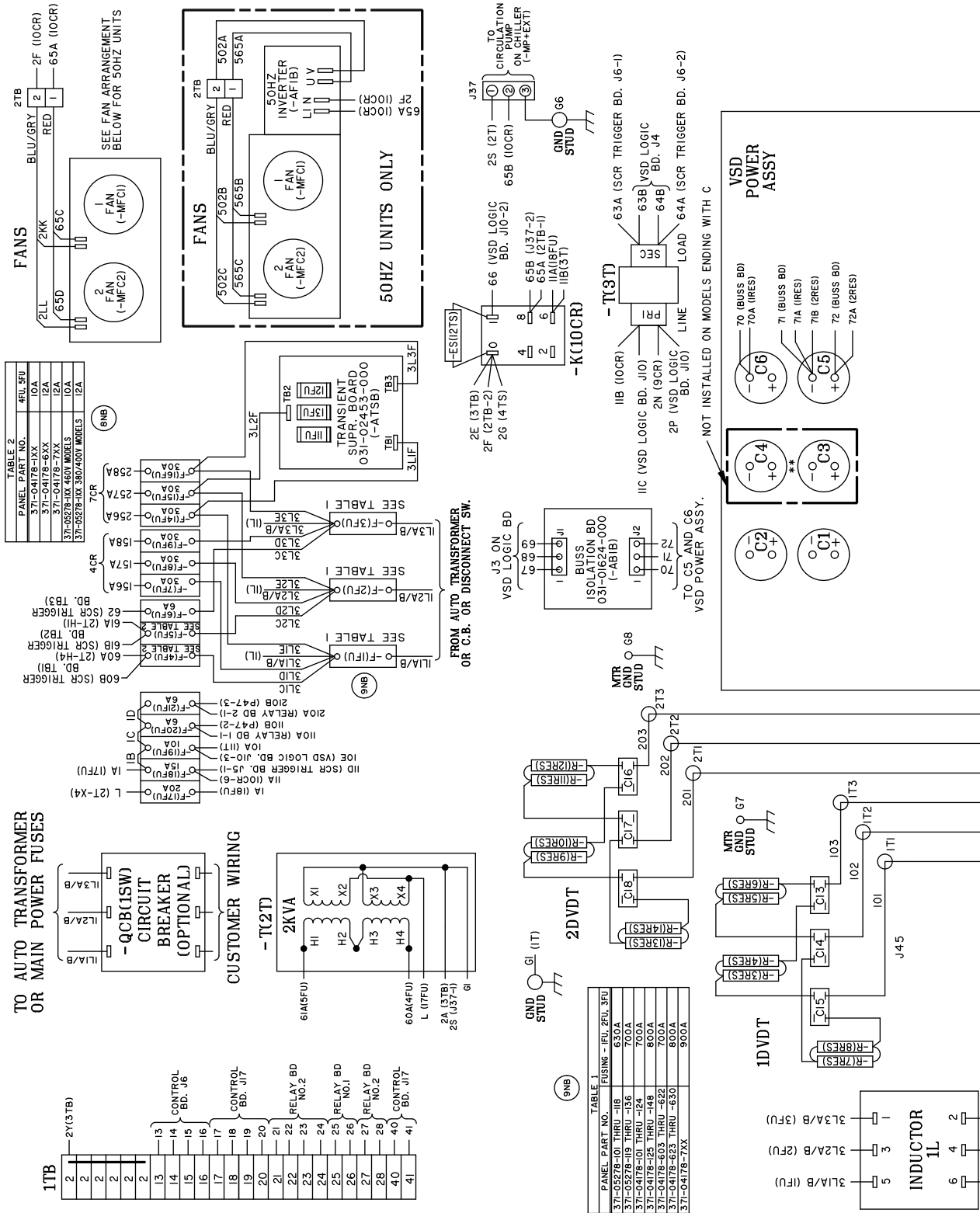
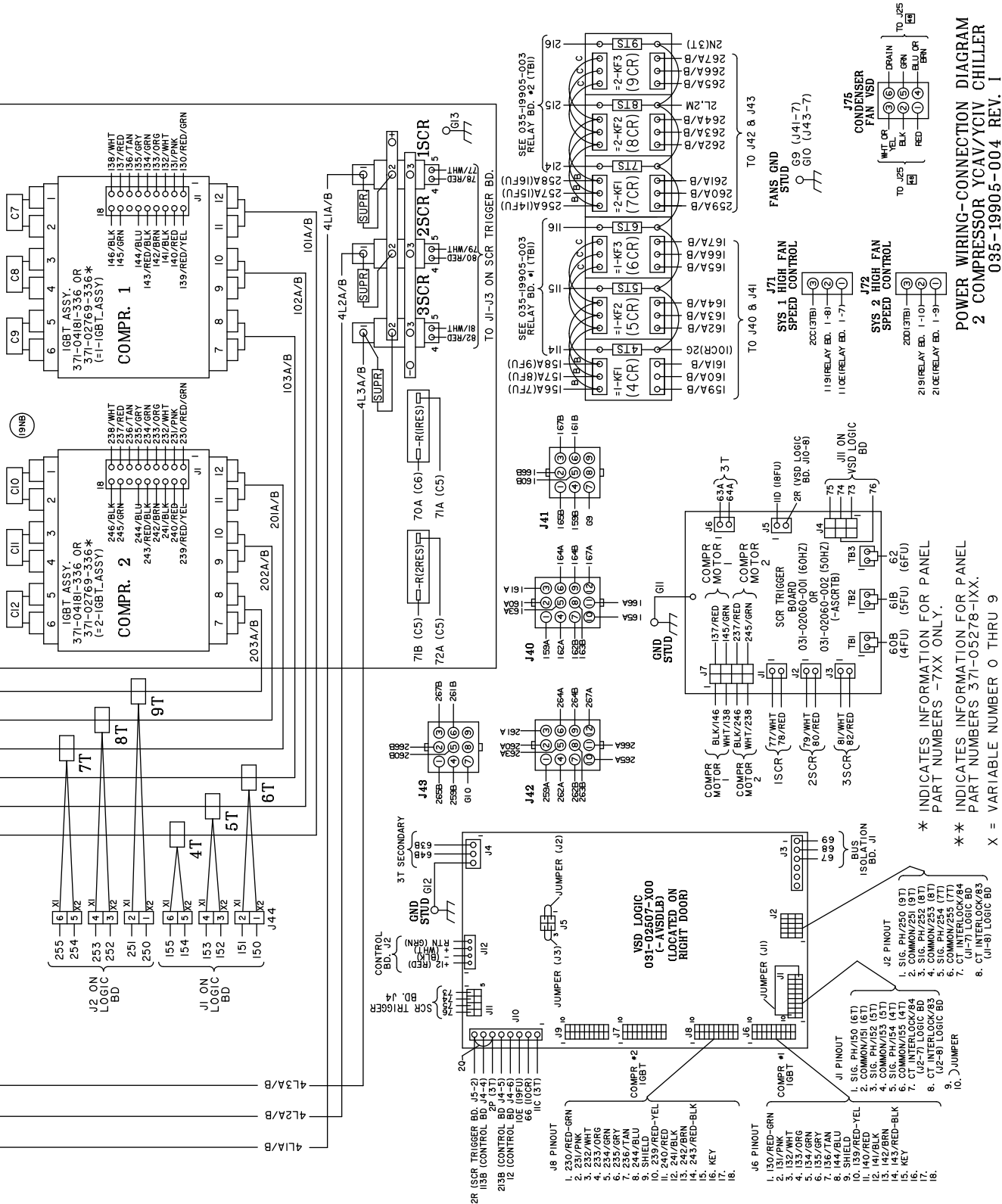

FIG. 12 - POWER WIRING CONNECTION DIAGRAM - YCIV0157-0267 2 COMPRESSOR MODELS



**POWER WIRING-CONNECTION DIAGRAM**  
**2 COMPRESSOR YCAV/YCIV CHILLER**  
**035-19905-004 REV. 1**

\* INDICATES INFORMATION FOR PANEL PART NUMBERS -7XX ONLY.  
 \*\* INDICATES INFORMATION FOR PANEL PART NUMBERS 371-05278-1XX.  
 X = VARIABLE NUMBER 0 THRU 9



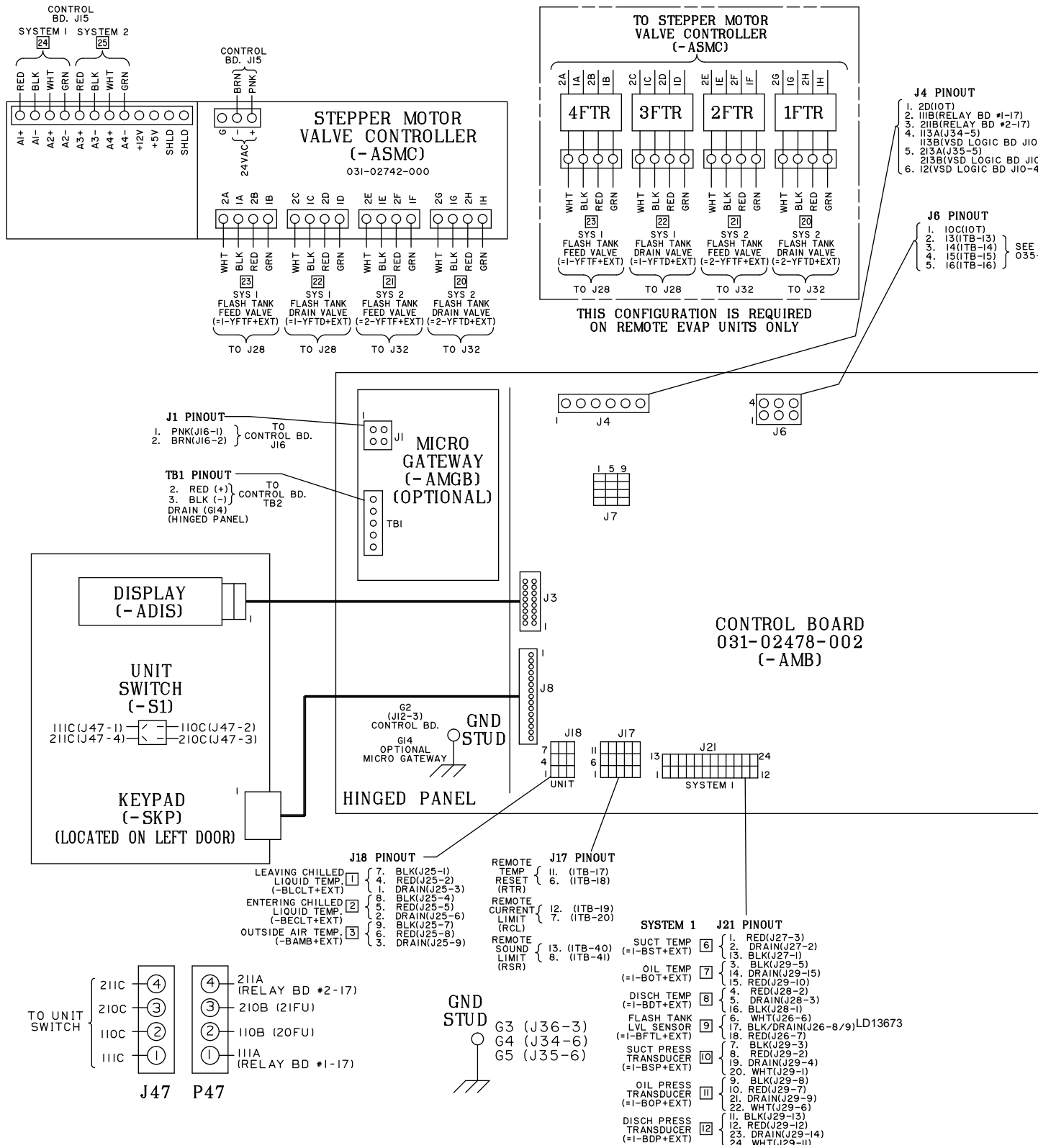

FIG. 13 - CONTROL WIRING CONNECTION DIAGRAM - YCIV0590-1000 2 COMPRESSOR MODELS

- J15 PINOUT**
- 1. RED (A1+)
  - 2. BLK (A1-)
  - 3. WHT (A2+)
  - 4. GRN (A2-)
  - 5. RED (A3+)
  - 6. BLK (A3-)
  - 7. WHT (A4+)
  - 8. GRN (A4-)
  - 9. PNK (+24VAC)
  - 10. BRN (-24VAC)
- 24 } TO STEPPER MOTOR VALVE CONTROLLER (-ASMC)  
25 }

- J13 PINOUT**
- 1. 32(IIT)
  - 2. 33(IIT)
  - 3. NO CONNECTION
  - 4. NO CONNECTION

- J12 PINOUT**
- 1. 30(IOT)
  - 2. 31(IOT)
  - 3. G2 (HINGED PANEL)

- J25 PINOUT**
- 1. RED (J75-1)
  - 2. BLK (J75-2)
  - 3. WHT OR YEL (J75-3)
  - 4. BLU OR BRN (J75-4)
  - 5. GRN (J75-5)
  - 6. DRAIN (J75-6)
- 48 } CONDENSER FAN VSD OPTION

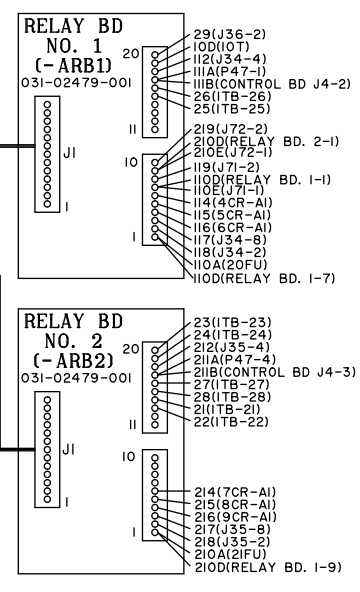

- LOGIC BD (J12)**
- 5. DRAIN
  - 4. GRN
  - 3. WHT
  - 2. BLK
  - 1. RED

- J16 PINOUT**
- 1. PNK } (J1) MICRO GATEWAY
  - 2. BRN } (-AMGB) (OPTIONAL)

- TB2 PINOUT**
- 3. RED (+) } (TB1) MICRO GATEWAY
  - 2. BLK (-) } (-AMGB) (OPTIONAL)

- SYSTEM 2 J22 PINOUT**
- 13 } 1. RED(J31-3) SUCT TEMP (=2-BST+EXT)
  - 14 } 2. DRAIN(J31-2)
  - 15 } 3. BLK(J31-1)
  - 16 } 4. BLK(J33-5)
  - 17 } 5. DRAIN(J33-5)
  - 18 } 6. RED(J33-10)
  - 19 } 7. RED(J32-2)
  - 20 } 8. DRAIN(J32-3)
  - 21 } 9. RED(J32-3)
  - 22 } 10. BLK(J32-1)
  - 23 } 11. WHT(J30-6)
  - 24 } 12. BLK/DRAIN(J30-8/9)
  - 25 } 13. RED(J30-7)
  - 26 } 14. BLK(J33-3)
  - 27 } 15. RED(J33-2)
  - 28 } 16. RED(J33-2)
  - 29 } 17. DRAIN(J33-4)
  - 30 } 18. WHT(J33-1)
  - 31 } 19. WHT(J33-1)
  - 32 } 20. BLK(J33-8)
  - 33 } 21. RED(J33-7)
  - 34 } 22. DRAIN(J33-9)
  - 35 } 23. WHT(J33-6)
  - 36 } 24. WHT(J33-6)
  - 37 } 25. BLK(J33-13)
  - 38 } 26. RED(J33-12)
  - 39 } 27. DRAIN(J33-14)
  - 40 } 28. WHT(J33-11)

- SYS NO #1 COMPRESSOR MOTOR TEMP SENSORS (=1-BMT+EXT)**
- 4 } 1. GRN (J26-1)
  - 5 } 2. RED (J26-2)
  - 6 } 3. BLK (J26-3)
  - 7 } 4. WHT (J26-4)
  - 8 } 5. DRAIN (J26-5)
- SYS NO #2 COMPRESSOR MOTOR TEMP SENSORS (=2-BMT+EXT)**
- 5 } 6. GRN (J30-1)
  - 6 } 7. RED (J30-2)
  - 7 } 8. BLK (J30-3)
  - 8 } 9. WHT (J30-4)
  - 9 } 10. DRAIN (J30-5)

CONTROL WIRING - CONNECTION DIAGRAM  
2 COMPRESSOR YCAV/YCIV CHILLER  
035-19905-003 REV I

LD13674



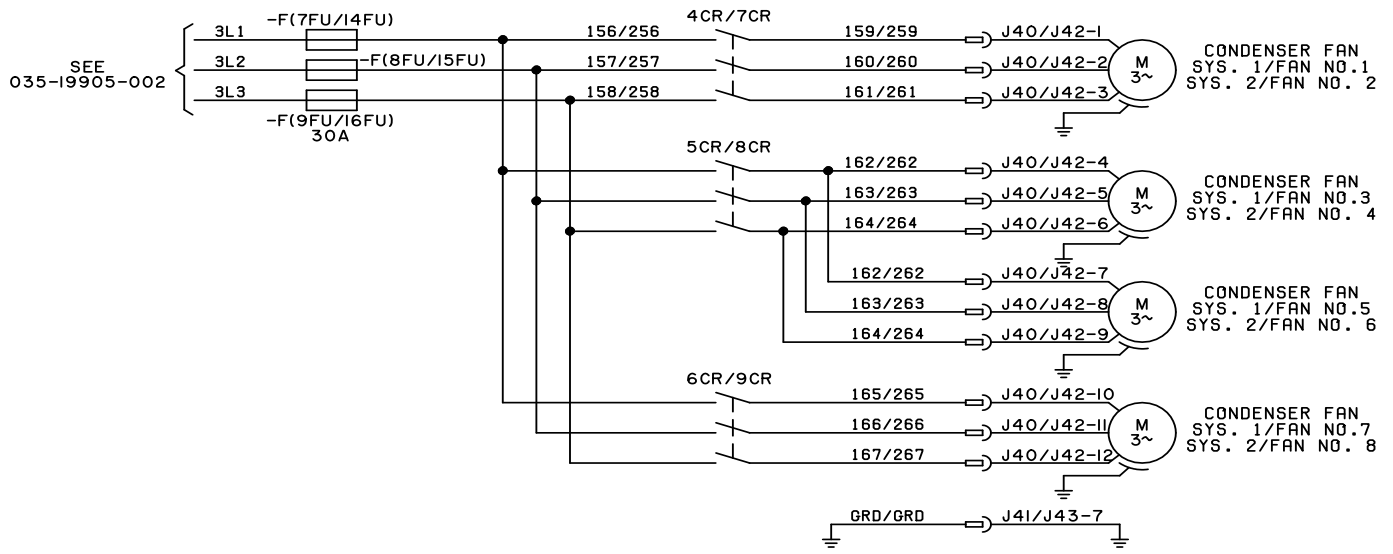

4 CONDENSER FAN ARRANGEMENT

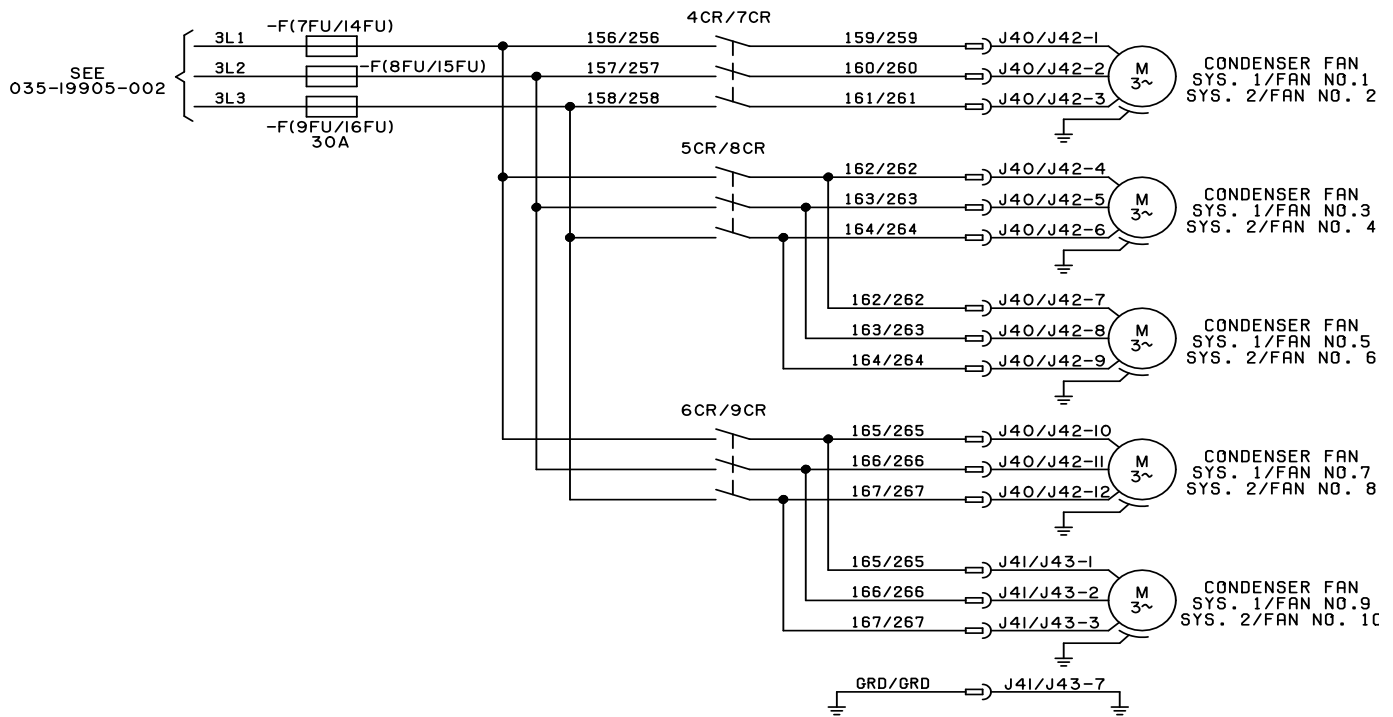

5 CONDENSER FAN ARRANGEMENT

POWER ELEMENTARY DIAGRAM  
 2 COMPRESSOR YCAV/YCIV CHILLER  
 035-19905-006 REV. -

LD13081

FIG. 14 - POWER ELEMENTARY WIRING DIAGRAM - YCIV0590-1000 2 COMPRESSOR MODELS

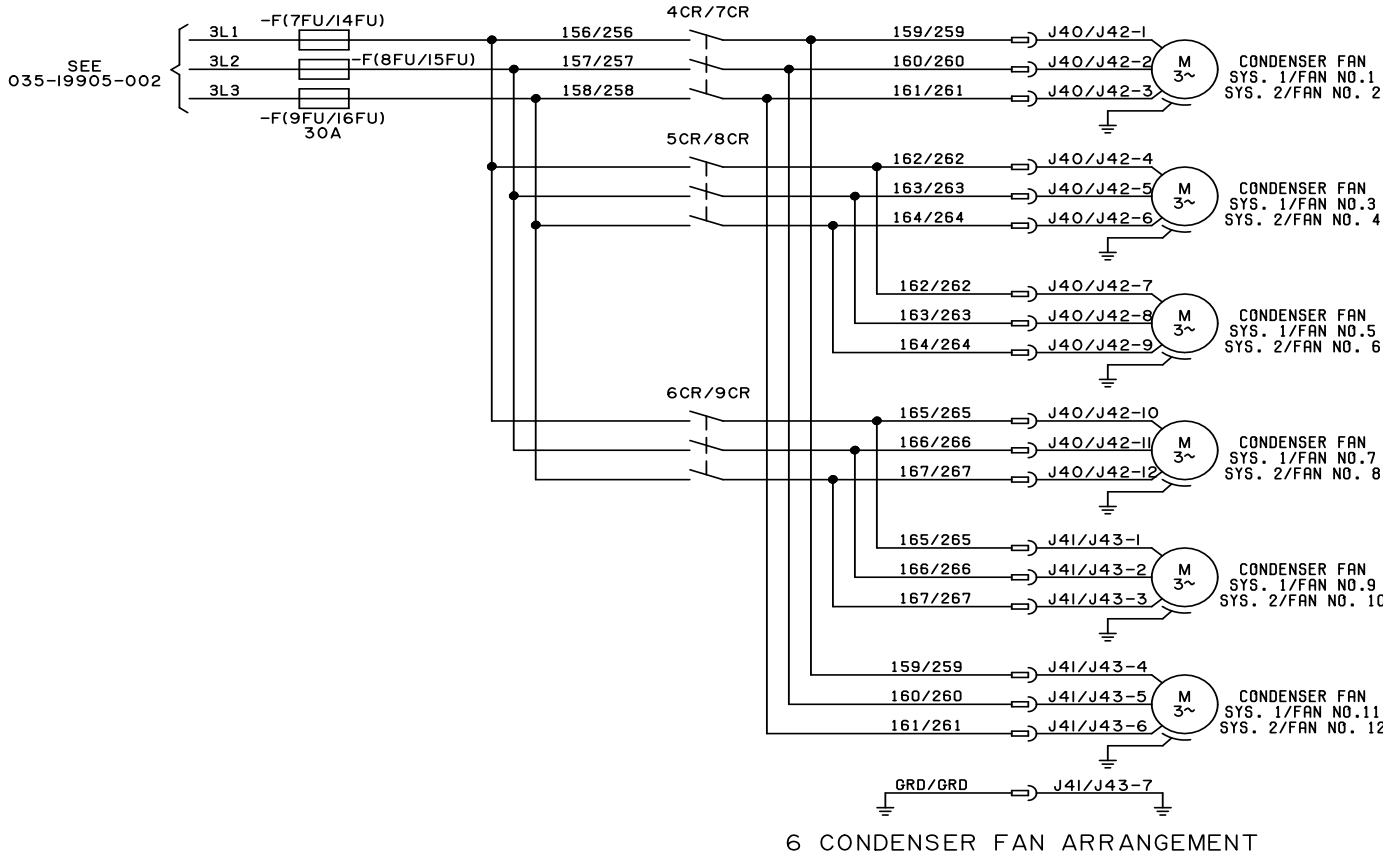

POWER ELEMENTARY DIAGRAM  
2 COMPRESSOR YCAV/YCIV CHILLER  
035-19905-006 REV. -

LD13082

FIG. 14 - POWER ELEMENTARY WIRING DIAGRAM - YCIV0590-1000 2 COMPRESSOR MODELS (CONT'D)

# LOCATION LABEL - YCIV0590-1000 2 COMPRESSOR MODELS

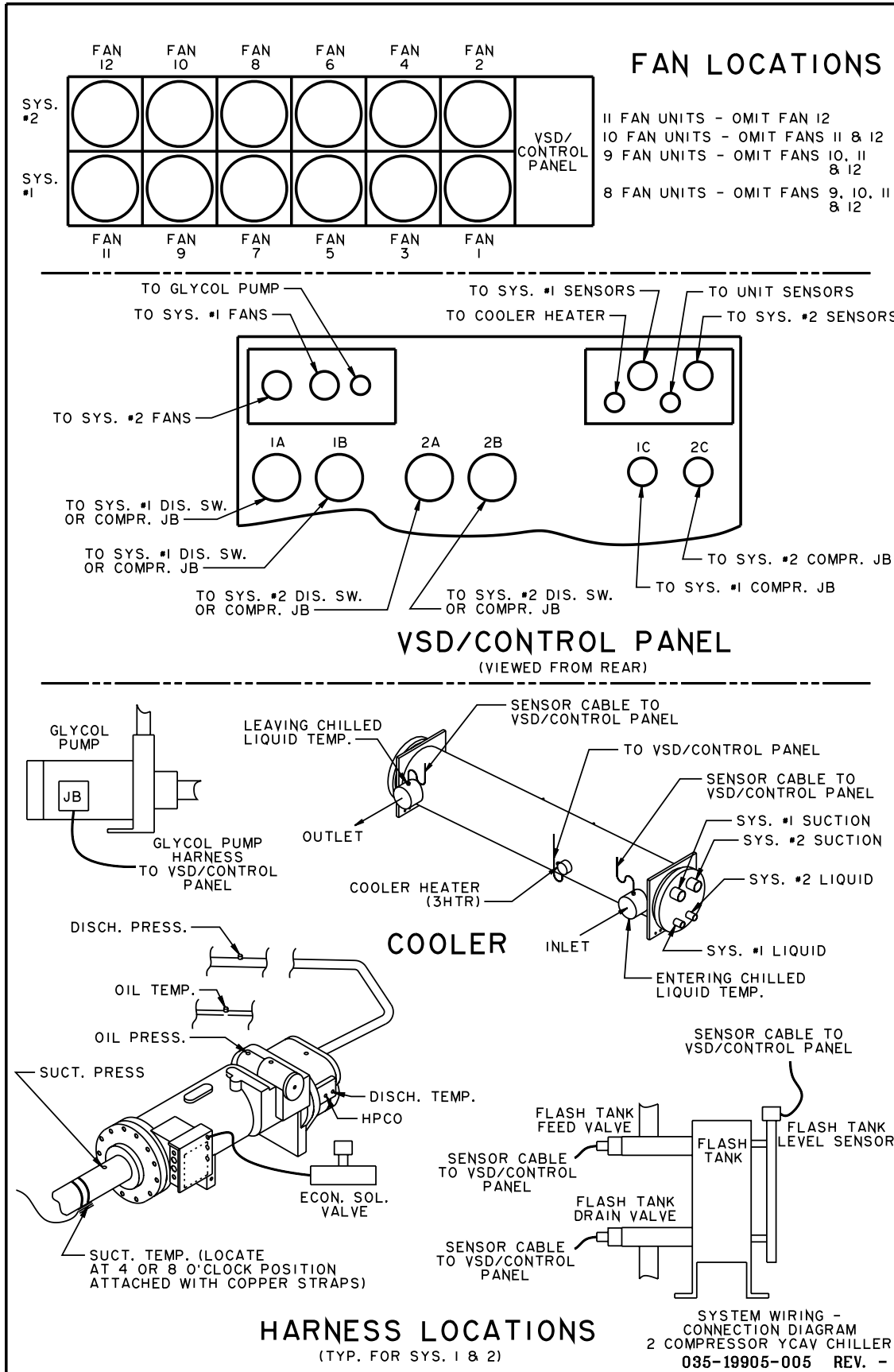

6

PANEL LAYOUT - YCIV0590-1000 2 COMPRESSOR MODELS

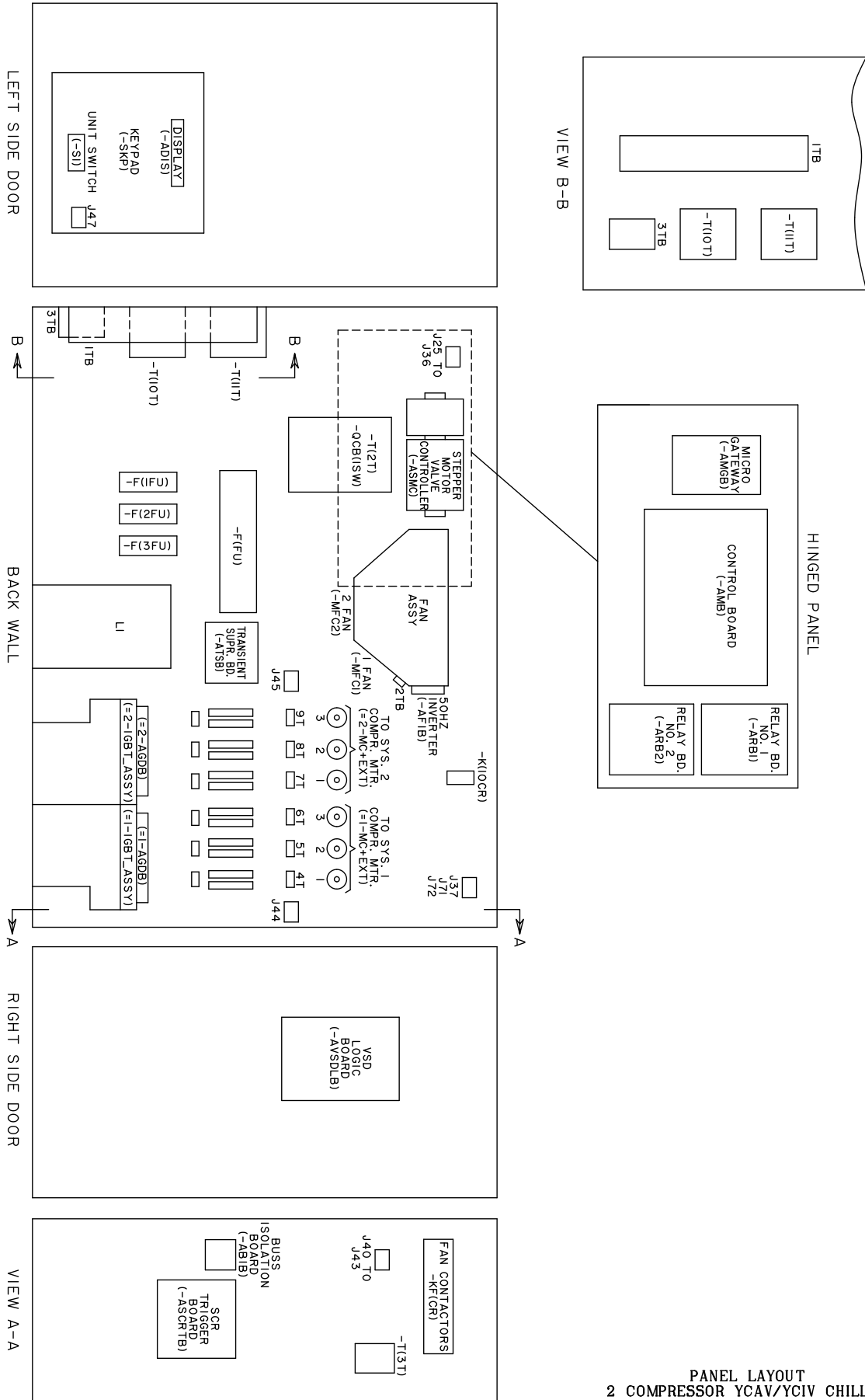

PANEL LAYOUT  
2 COMPRESSOR YCAV/YCIV CHILLER  
035-19905-007 REV. B

**THIS PAGE INTENTIONALLY LEFT BLANK**

ELECTRICAL WIRING DIAGRAMS - 3 COMPRESSOR MODELS

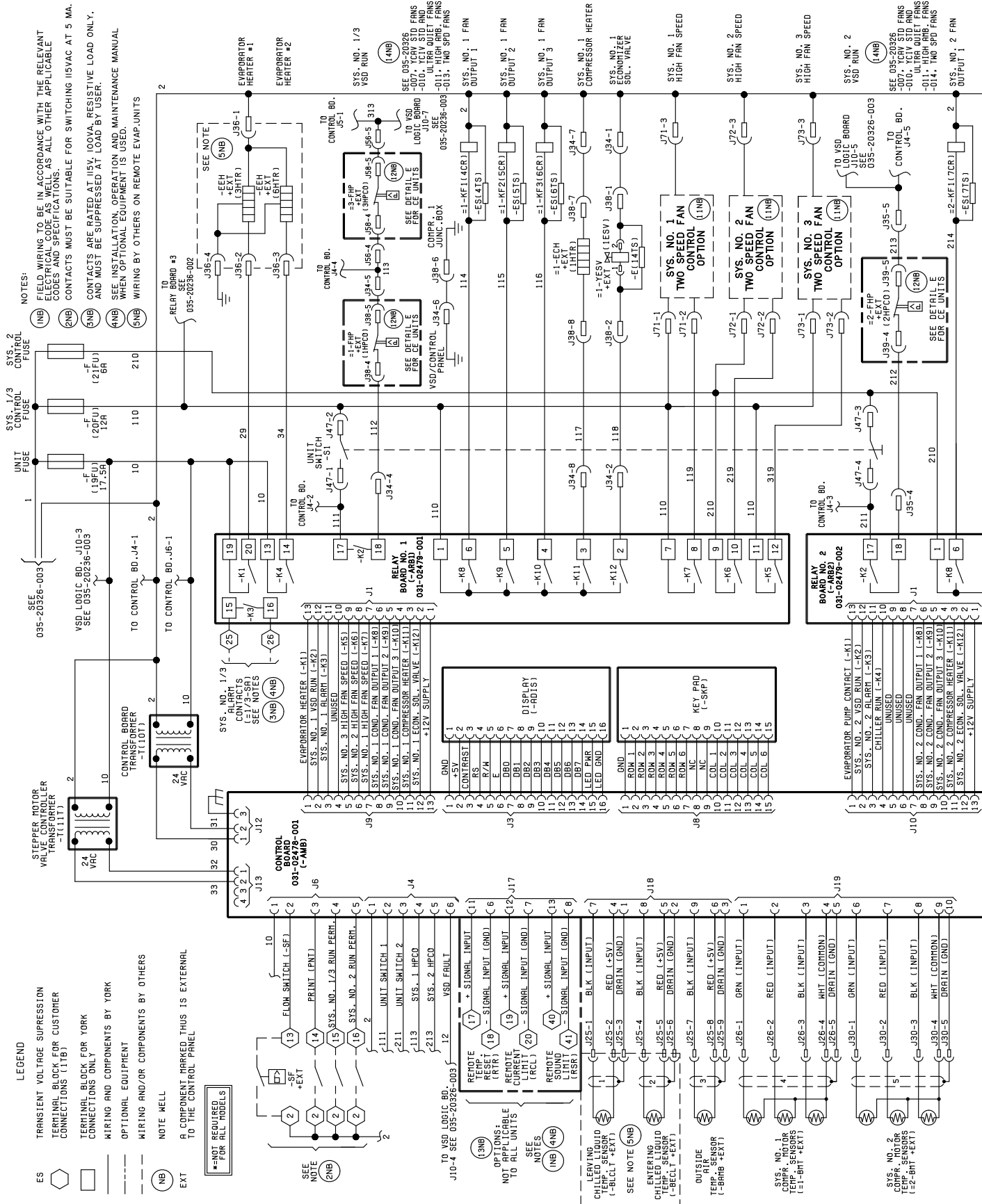
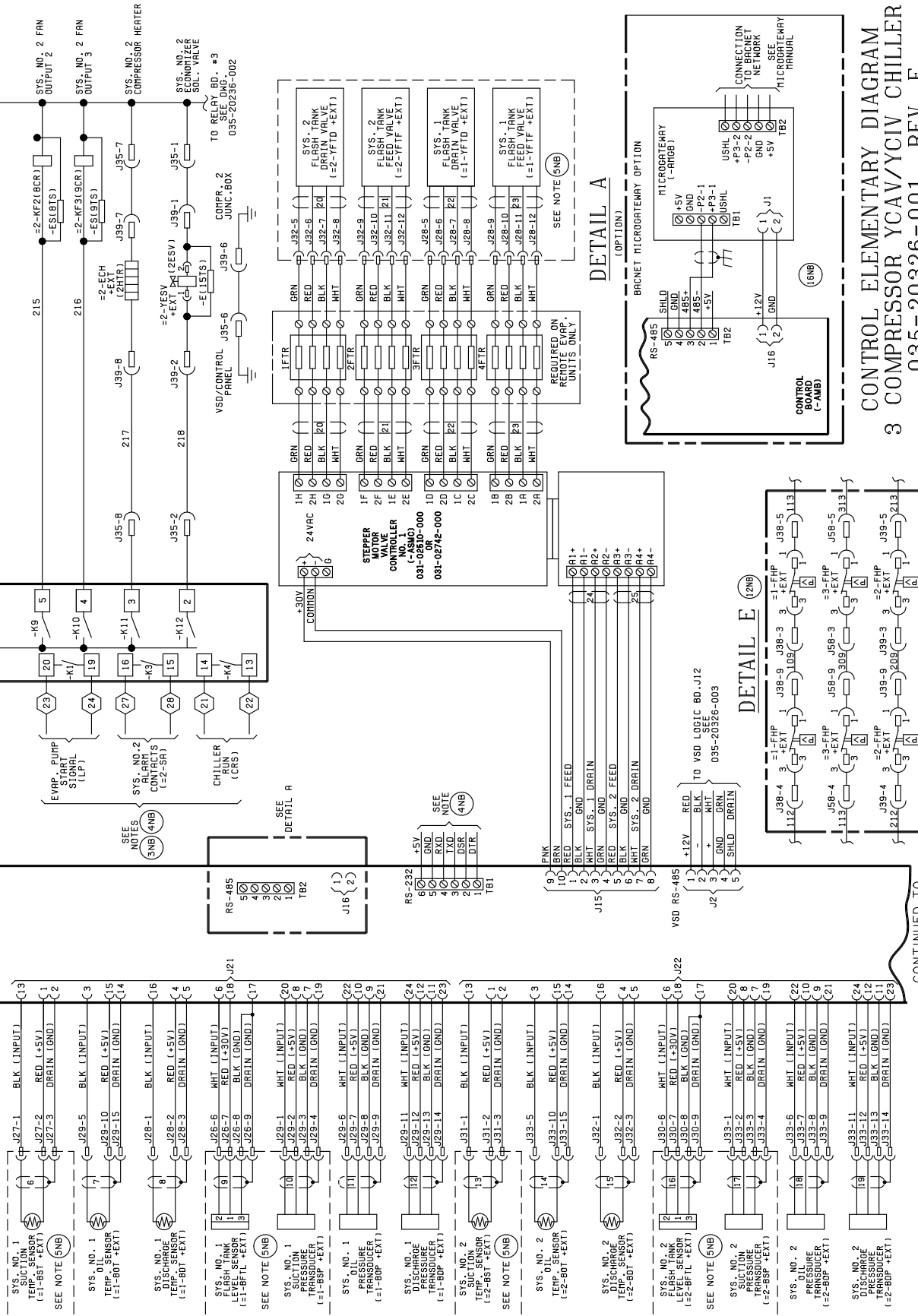
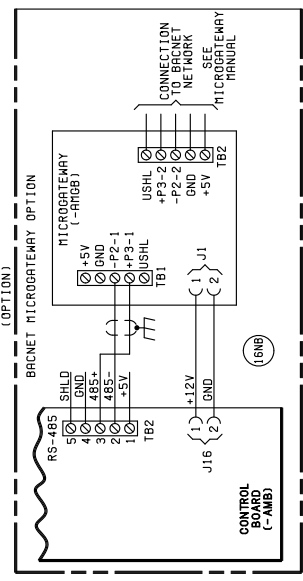

FIG. 15 - CONTROL ELEMENTARY DIAGRAM - YCIV1050-1500 3 COMPRESSOR MODELS



DETAIL A



DETAIL E

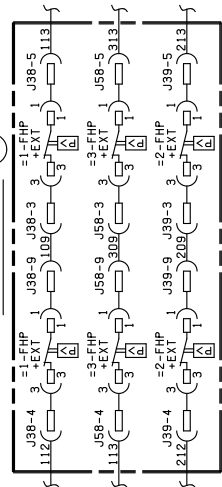

**CONTROL ELEMENTARY DIAGRAM**  
**3 COMPRESSOR YCAV/YCIV CHILLER**  
**035-20326-001 REV. F**

CONTINUED TO 035-20326-002

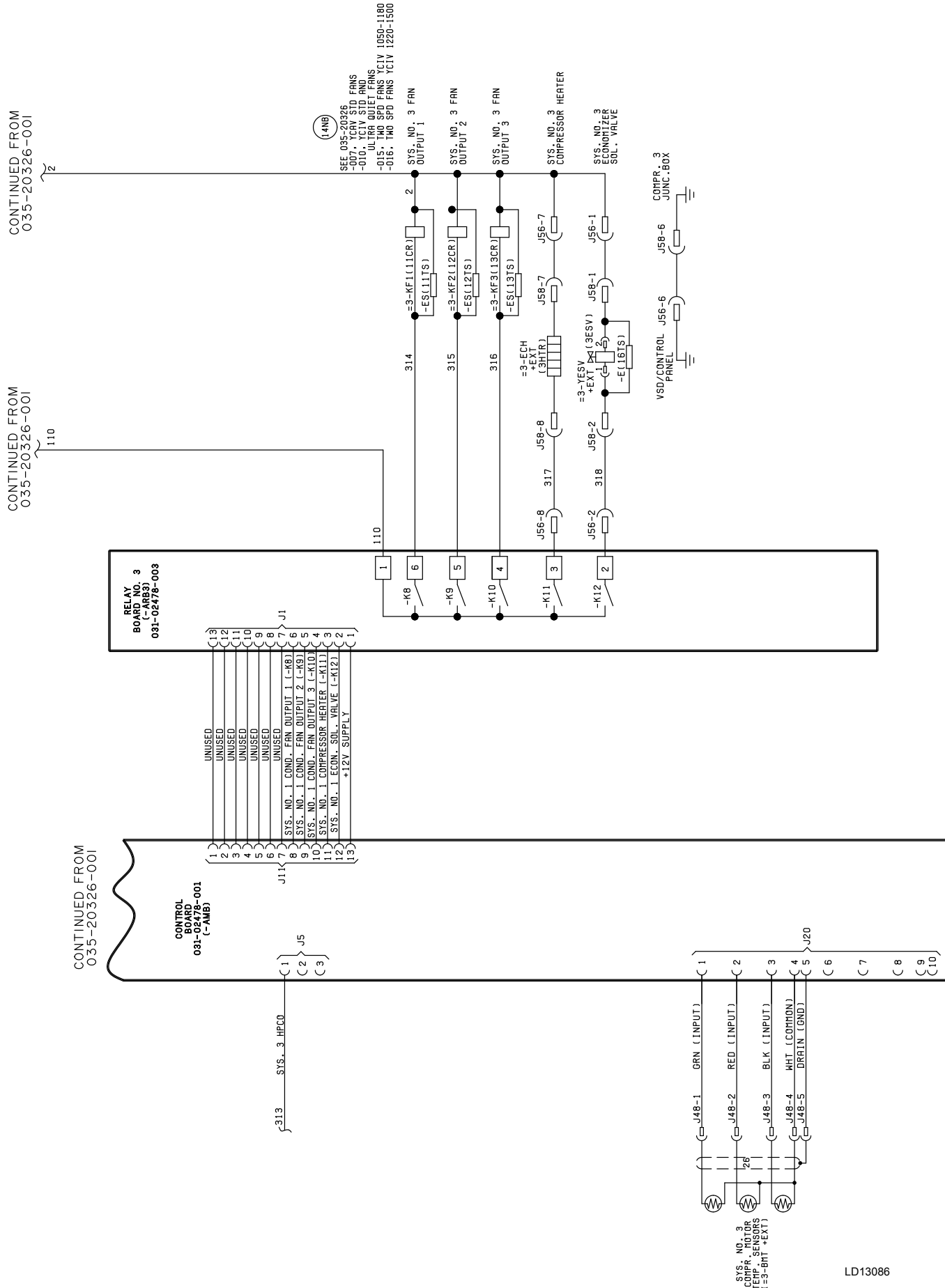

LD13086

FIG. 16 - CONTROL ELEMENTARY DIAGRAM - YCIV1050-1500 3 COMPRESSOR MODELS

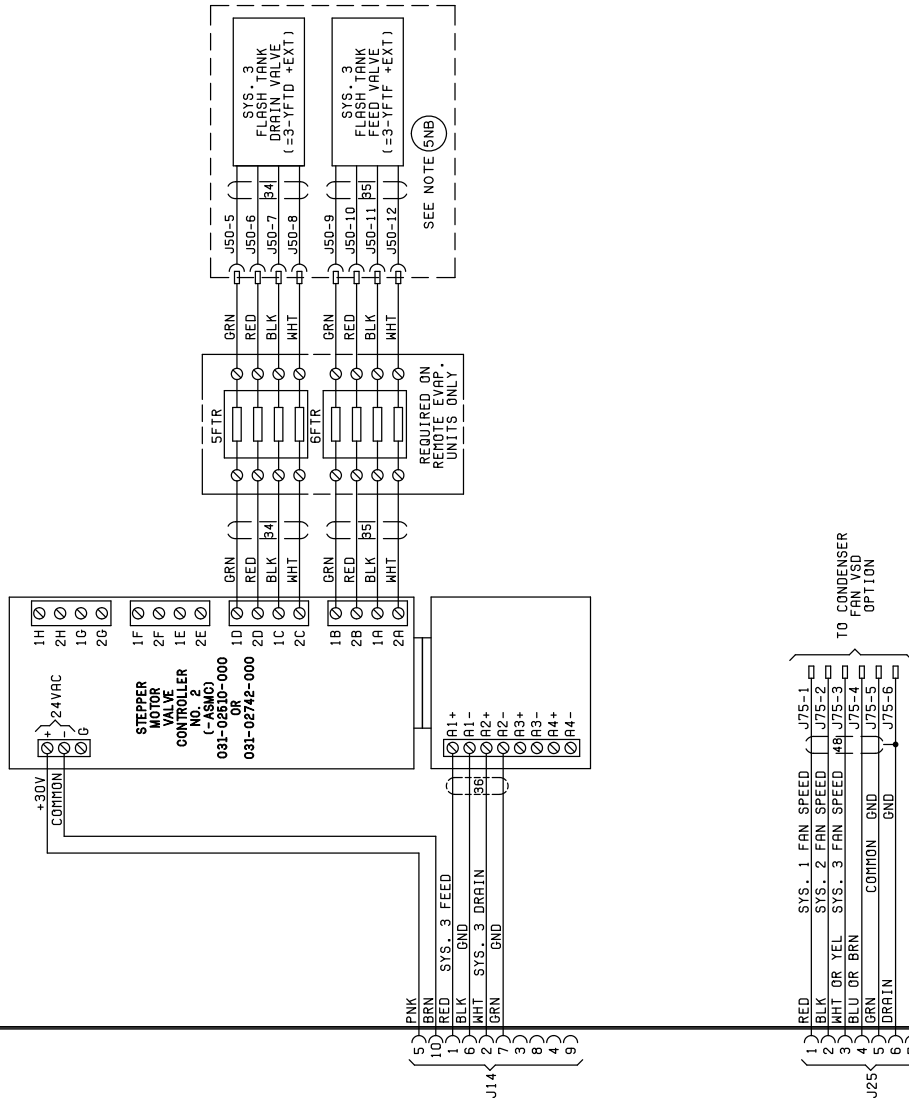
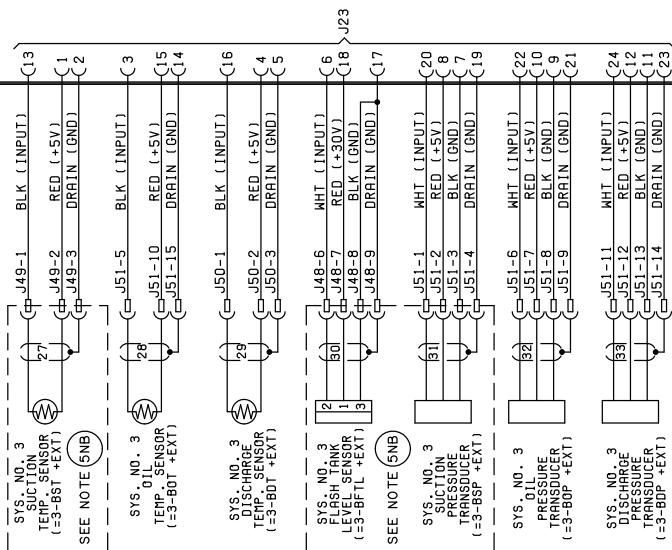

CONTROL ELEMENTARY DIAGRAM  
 3 COMPRESSOR YCAV/YCIV CHILLER  
 035-20326-002 REV. F

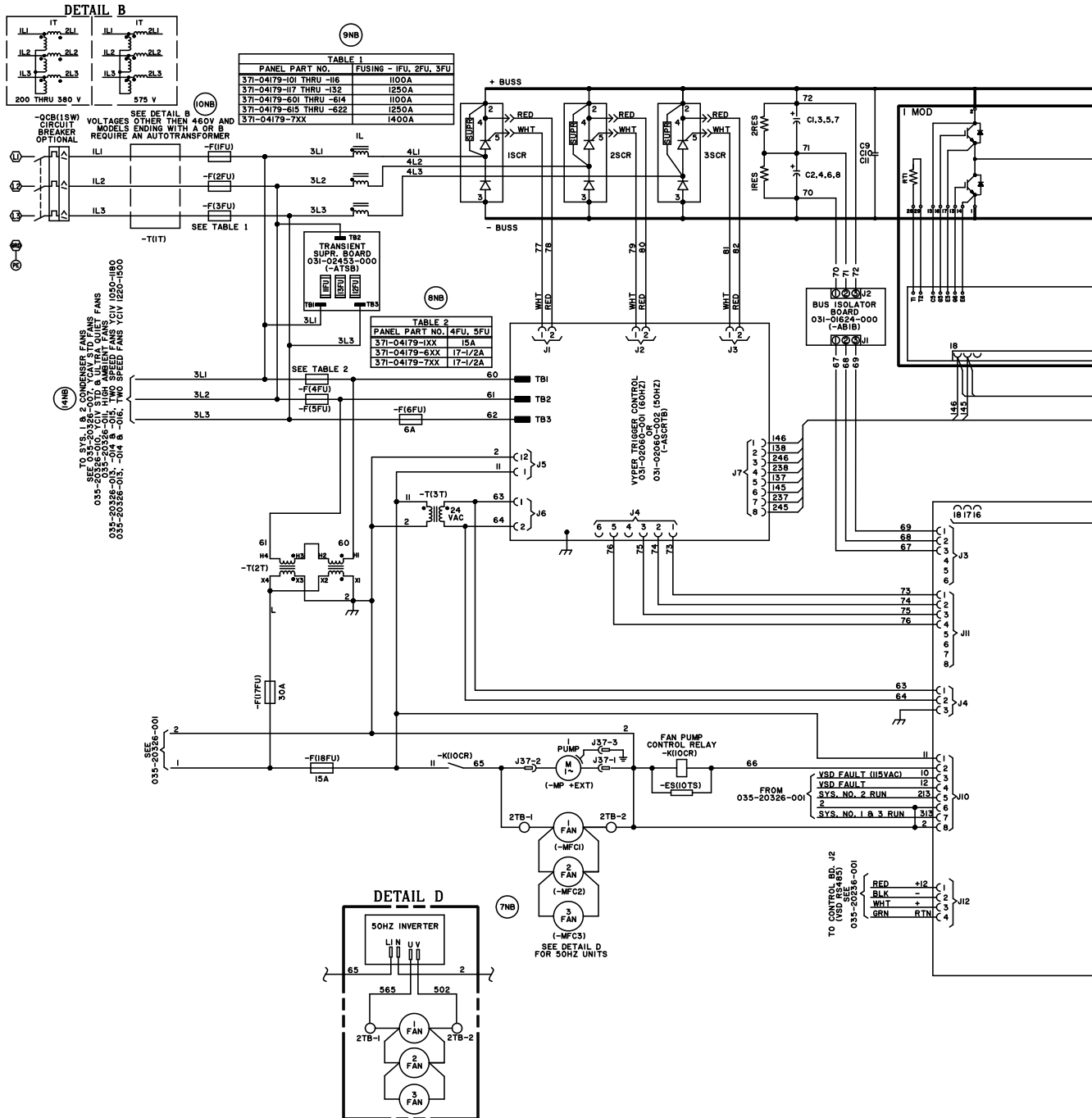

LD13088

FIG. 17 - POWER ELEMENTARY DIAGRAM - YCIV1050-1500 3 COMPRESSOR MODELS

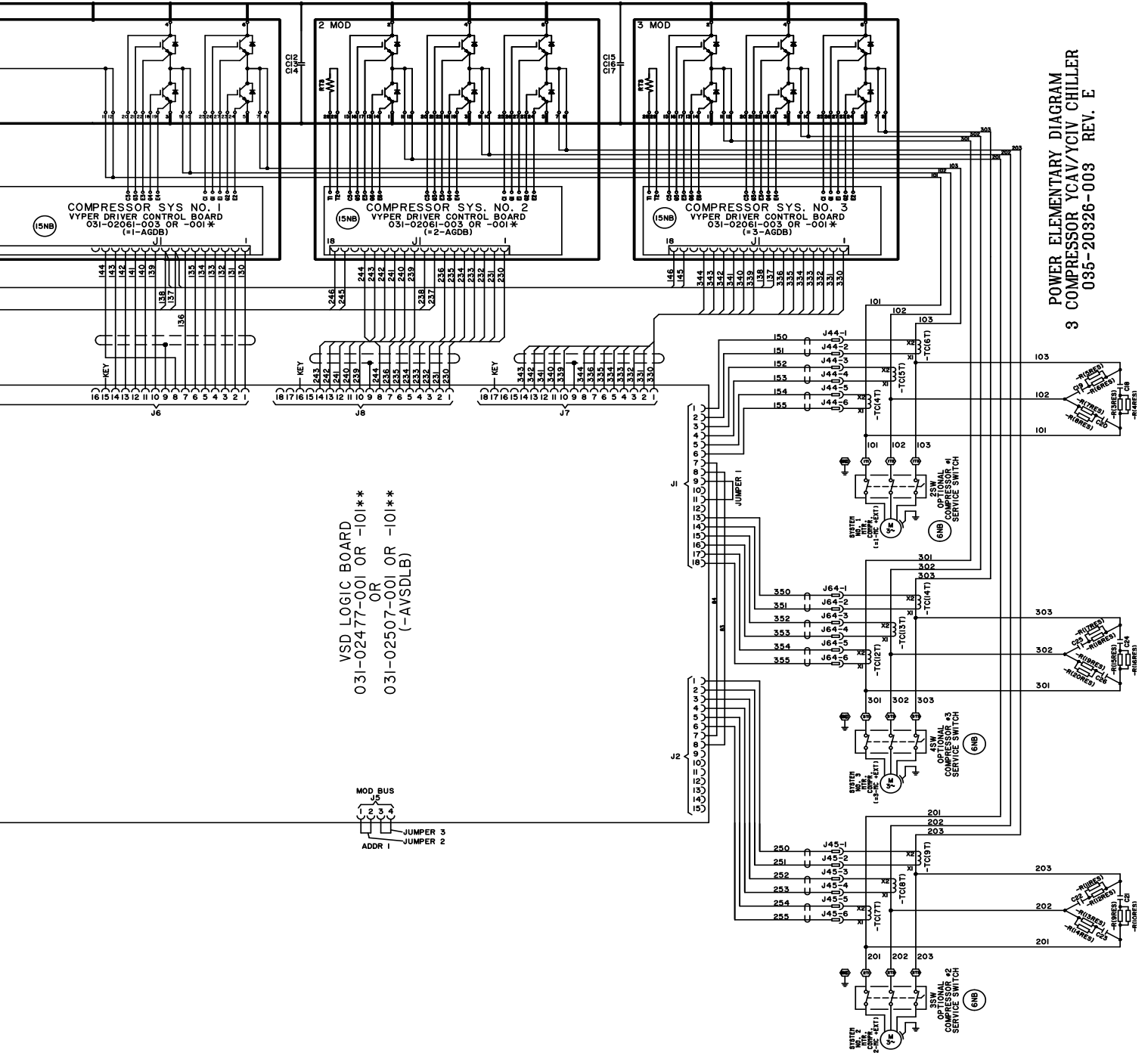

POWER ELEMENTARY DIAGRAM  
 3 COMPRESSOR YCAV/YCIV CHILLER  
 035-20926-003 REV. E

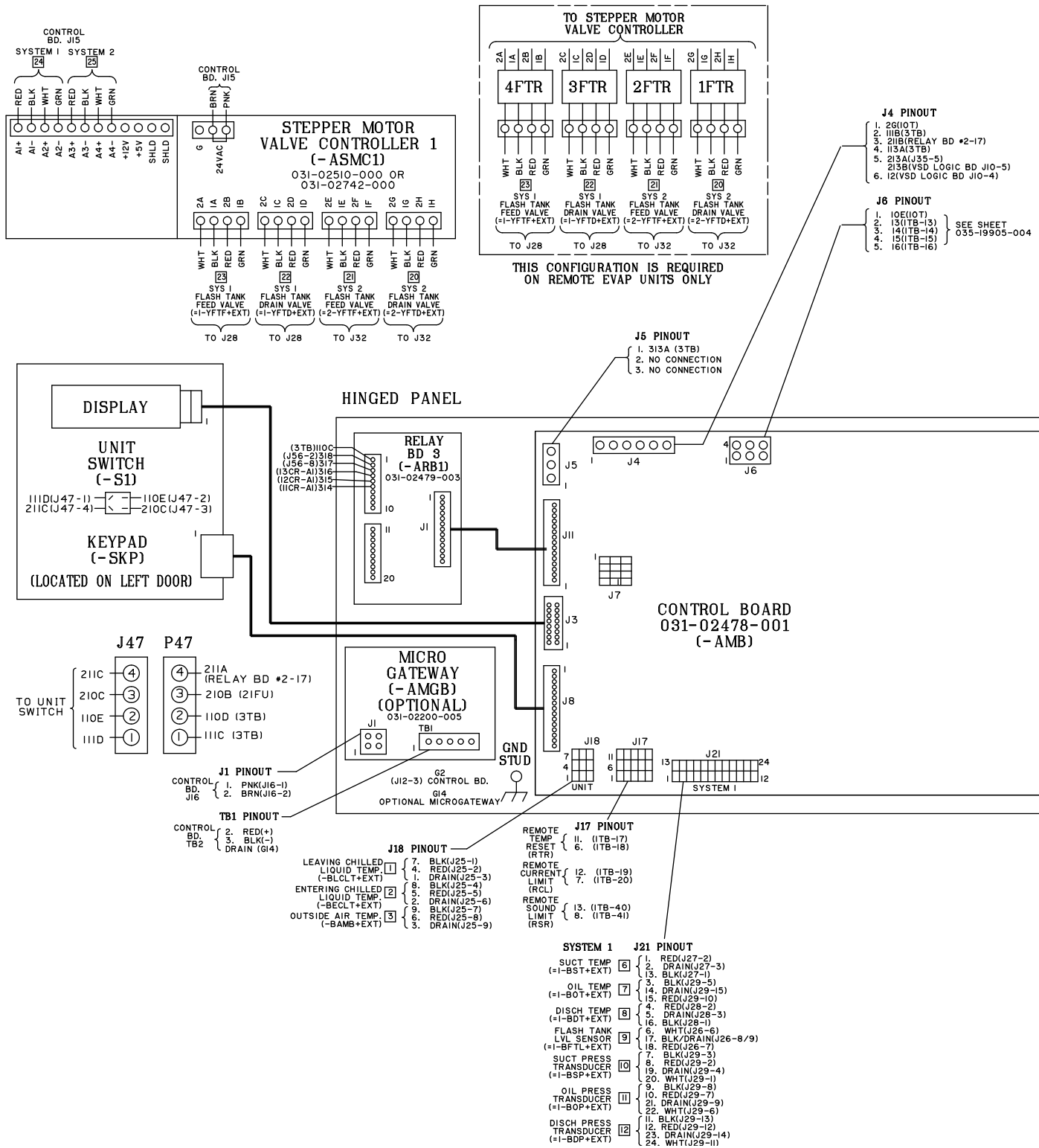

LD13090

FIG. 18 - CONTROL WIRING CONNECTION DIAGRAM - YCIV1050-1500 3 COMPRESSOR MODELS

- J15 PINOUT**
- 1. RED (A1+)
  - 2. BLK (A1-)
  - 3. WHT (A2+)
  - 4. GRN (A2-)
  - 5. RED (A3+)
  - 6. BLK (A3-)
  - 7. WHT (A4+)
  - 8. GRN (A4-)
  - 9. PNK (24VAC)
  - 10. BRN (24VAC)
- TO STEPPER MOTOR VALVE CONTROLLER #1 (-ASMC1)

- J14 PINOUT**
- 1. RED (A1+)
  - 2. WHT (A2+)
  - 7. GRN (A2-)
  - 8.
  - 9.
  - 5. PNK (24VAC)
  - 10. BRN (24VAC)
- TO STEPPER MOTOR VALVE CONTROLLER #2 (-ASMC2)

- J19 PINOUT**
- 1. 32(IIT)
  - 2. 33(IIT)
  - 3. NO CONNECTION
  - 4. NO CONNECTION

- J12 PINOUT**
- 1. 30(IOT)
  - 2. 31(IOT)
  - 3. G2 (HINGED PANEL)

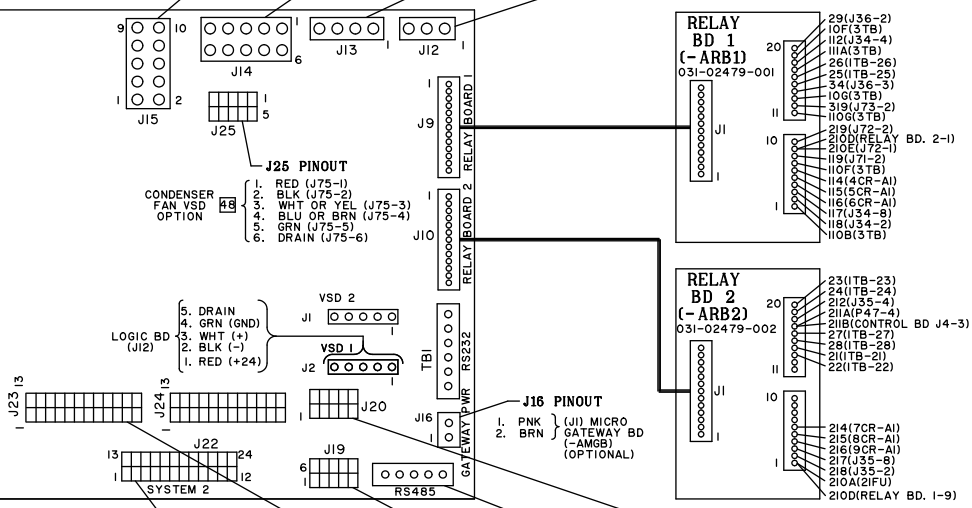

- SYSTEM 2 J22 PINOUT**
- 1. RED(J31-2)
  - 2. DRAIN(J31-3)
  - 3. BLK(J33-1)
  - 4. DRAIN(J33-15)
  - 5. RED(J32-2)
  - 6. WHT(J30-6)
  - 7. BLK/DRAIN(J30-8/9)
  - 8. RED(J33-2)
  - 9. DRAIN(J33-4)
  - 10. WHT(J33-1)
  - 11. BLK(J33-8)
  - 12. DRAIN(J33-9)
  - 13. WHT(J33-6)
  - 14. RED(J33-12)
  - 15. DRAIN(J33-14)
  - 16. WHT(J33-11)

- SYSTEM 3 J23 PINOUT**
- 1. RED(J49-2)
  - 2. DRAIN(J49-3)
  - 3. BLK(J49-1)
  - 4. DRAIN(J51-15)
  - 5. RED(J50-1)
  - 6. DRAIN(J50-3)
  - 7. BLK(J48-6)
  - 8. WHT/DRAIN(J48-8/9)
  - 9. RED(J48-7)
  - 10. DRAIN(J51-4)
  - 11. WHT(J51-1)
  - 12. BLK(J51-8)
  - 13. RED(J51-7)
  - 14. DRAIN(J51-9)
  - 15. WHT(J51-6)
  - 16. BLK(J51-3)
  - 17. RED(J51-2)
  - 18. DRAIN(J51-4)
  - 19. WHT(J51-1)
  - 20. BLK(J51-8)
  - 21. RED(J51-7)
  - 22. DRAIN(J51-9)
  - 23. WHT(J51-6)
  - 24. BLK(J51-3)
  - 25. RED(J51-2)
  - 26. DRAIN(J51-4)
  - 27. WHT(J51-1)
  - 28. BLK(J51-8)
  - 29. RED(J51-7)
  - 30. DRAIN(J51-9)
  - 31. WHT(J51-6)
  - 32. BLK(J51-3)
  - 33. RED(J51-2)
  - 34. DRAIN(J51-4)
  - 35. WHT(J51-1)
  - 36. BLK(J51-8)
  - 37. RED(J51-7)
  - 38. DRAIN(J51-9)
  - 39. WHT(J51-6)
  - 40. BLK(J51-3)
  - 41. RED(J51-2)
  - 42. DRAIN(J51-4)
  - 43. WHT(J51-1)
  - 44. BLK(J51-8)
  - 45. RED(J51-7)
  - 46. DRAIN(J51-9)
  - 47. WHT(J51-6)
  - 48. BLK(J51-3)
  - 49. RED(J51-2)
  - 50. DRAIN(J51-4)
  - 51. WHT(J51-1)
  - 52. BLK(J51-8)
  - 53. RED(J51-7)
  - 54. DRAIN(J51-9)
  - 55. WHT(J51-6)
  - 56. BLK(J51-3)
  - 57. RED(J51-2)
  - 58. DRAIN(J51-4)
  - 59. WHT(J51-1)
  - 60. BLK(J51-8)
  - 61. RED(J51-7)
  - 62. DRAIN(J51-9)
  - 63. WHT(J51-6)
  - 64. BLK(J51-3)
  - 65. RED(J51-2)
  - 66. DRAIN(J51-4)
  - 67. WHT(J51-1)
  - 68. BLK(J51-8)
  - 69. RED(J51-7)
  - 70. DRAIN(J51-9)
  - 71. WHT(J51-6)
  - 72. BLK(J51-3)
  - 73. RED(J51-2)
  - 74. DRAIN(J51-4)
  - 75. WHT(J51-1)
  - 76. BLK(J51-8)
  - 77. RED(J51-7)
  - 78. DRAIN(J51-9)
  - 79. WHT(J51-6)
  - 80. BLK(J51-3)
  - 81. RED(J51-2)
  - 82. DRAIN(J51-4)
  - 83. WHT(J51-1)
  - 84. BLK(J51-8)
  - 85. RED(J51-7)
  - 86. DRAIN(J51-9)
  - 87. WHT(J51-6)
  - 88. BLK(J51-3)
  - 89. RED(J51-2)
  - 90. DRAIN(J51-4)
  - 91. WHT(J51-1)
  - 92. BLK(J51-8)
  - 93. RED(J51-7)
  - 94. DRAIN(J51-9)
  - 95. WHT(J51-6)
  - 96. BLK(J51-3)
  - 97. RED(J51-2)
  - 98. DRAIN(J51-4)
  - 99. WHT(J51-1)
  - 100. BLK(J51-8)
  - 101. RED(J51-7)
  - 102. DRAIN(J51-9)
  - 103. WHT(J51-6)
  - 104. BLK(J51-3)
  - 105. RED(J51-2)
  - 106. DRAIN(J51-4)
  - 107. WHT(J51-1)
  - 108. BLK(J51-8)
  - 109. RED(J51-7)
  - 110. DRAIN(J51-9)
  - 111. WHT(J51-6)
  - 112. BLK(J51-3)
  - 113. RED(J51-2)
  - 114. DRAIN(J51-4)
  - 115. WHT(J51-1)
  - 116. BLK(J51-8)
  - 117. RED(J51-7)
  - 118. DRAIN(J51-9)
  - 119. WHT(J51-6)
  - 120. BLK(J51-3)
  - 121. RED(J51-2)
  - 122. DRAIN(J51-4)
  - 123. WHT(J51-1)
  - 124. BLK(J51-8)
  - 125. RED(J51-7)
  - 126. DRAIN(J51-9)
  - 127. WHT(J51-6)
  - 128. BLK(J51-3)
  - 129. RED(J51-2)
  - 130. DRAIN(J51-4)
  - 131. WHT(J51-1)
  - 132. BLK(J51-8)
  - 133. RED(J51-7)
  - 134. DRAIN(J51-9)
  - 135. WHT(J51-6)
  - 136. BLK(J51-3)
  - 137. RED(J51-2)
  - 138. DRAIN(J51-4)
  - 139. WHT(J51-1)
  - 140. BLK(J51-8)
  - 141. RED(J51-7)
  - 142. DRAIN(J51-9)
  - 143. WHT(J51-6)
  - 144. BLK(J51-3)
  - 145. RED(J51-2)
  - 146. DRAIN(J51-4)
  - 147. WHT(J51-1)
  - 148. BLK(J51-8)
  - 149. RED(J51-7)
  - 150. DRAIN(J51-9)
  - 151. WHT(J51-6)
  - 152. BLK(J51-3)
  - 153. RED(J51-2)
  - 154. DRAIN(J51-4)
  - 155. WHT(J51-1)
  - 156. BLK(J51-8)
  - 157. RED(J51-7)
  - 158. DRAIN(J51-9)
  - 159. WHT(J51-6)
  - 160. BLK(J51-3)
  - 161. RED(J51-2)
  - 162. DRAIN(J51-4)
  - 163. WHT(J51-1)
  - 164. BLK(J51-8)
  - 165. RED(J51-7)
  - 166. DRAIN(J51-9)
  - 167. WHT(J51-6)
  - 168. BLK(J51-3)
  - 169. RED(J51-2)
  - 170. DRAIN(J51-4)
  - 171. WHT(J51-1)
  - 172. BLK(J51-8)
  - 173. RED(J51-7)
  - 174. DRAIN(J51-9)
  - 175. WHT(J51-6)
  - 176. BLK(J51-3)
  - 177. RED(J51-2)
  - 178. DRAIN(J51-4)
  - 179. WHT(J51-1)
  - 180. BLK(J51-8)
  - 181. RED(J51-7)
  - 182. DRAIN(J51-9)
  - 183. WHT(J51-6)
  - 184. BLK(J51-3)
  - 185. RED(J51-2)
  - 186. DRAIN(J51-4)
  - 187. WHT(J51-1)
  - 188. BLK(J51-8)
  - 189. RED(J51-7)
  - 190. DRAIN(J51-9)
  - 191. WHT(J51-6)
  - 192. BLK(J51-3)
  - 193. RED(J51-2)
  - 194. DRAIN(J51-4)
  - 195. WHT(J51-1)
  - 196. BLK(J51-8)
  - 197. RED(J51-7)
  - 198. DRAIN(J51-9)
  - 199. WHT(J51-6)
  - 200. BLK(J51-3)

- TB2 PINOUT**
- 1. MICRO GATEWAY BD TBI (-AMGB) (OPTIONAL)
  - 2. RED(+)
  - 3. BLK(-)

- J20 PINOUT**
- 1. GRN (J48-1)
  - 2. RED (J48-2)
  - 3. BLK (J48-3)
  - 4. WHT (J48-4)
  - 5. DRAIN (J48-5)
  - 6.
  - 7.
  - 8.
  - 9.
  - 10.

- J19 PINOUT**
- 1. GRN (J26-1)
  - 2. RED (J26-2)
  - 3. BLK (J26-3)
  - 4. WHT (J26-4)
  - 5. DRAIN (J26-5)
  - 6. GRN (J30-1)
  - 7. RED (J30-2)
  - 8. BLK (J30-3)
  - 9. WHT (J30-4)
  - 10. DRAIN (J30-5)

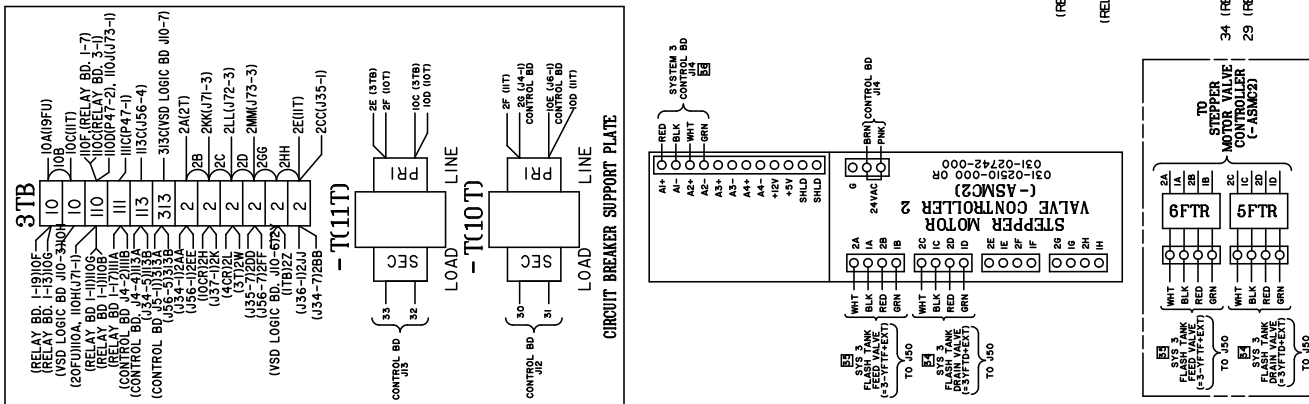
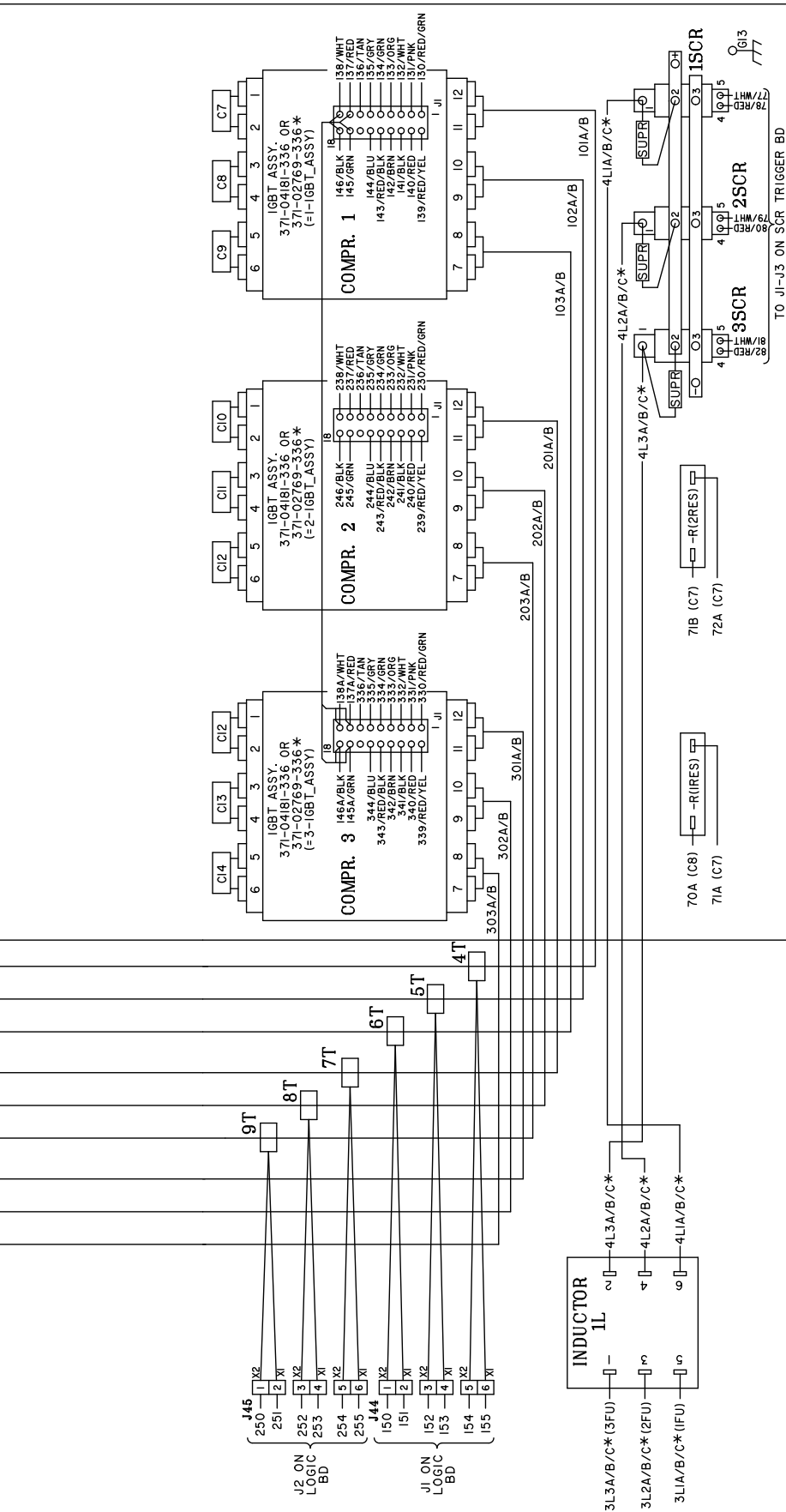

FIG. 18 - CONTROL WIRING CONNECTION DIAGRAM - YCIV1050-1500 3 COMPRESSOR MODELS (CONT'D)

**THIS PAGE INTENTIONALLY LEFT BLANK**







**THIS PAGE INTENTIONALLY LEFT BLANK**

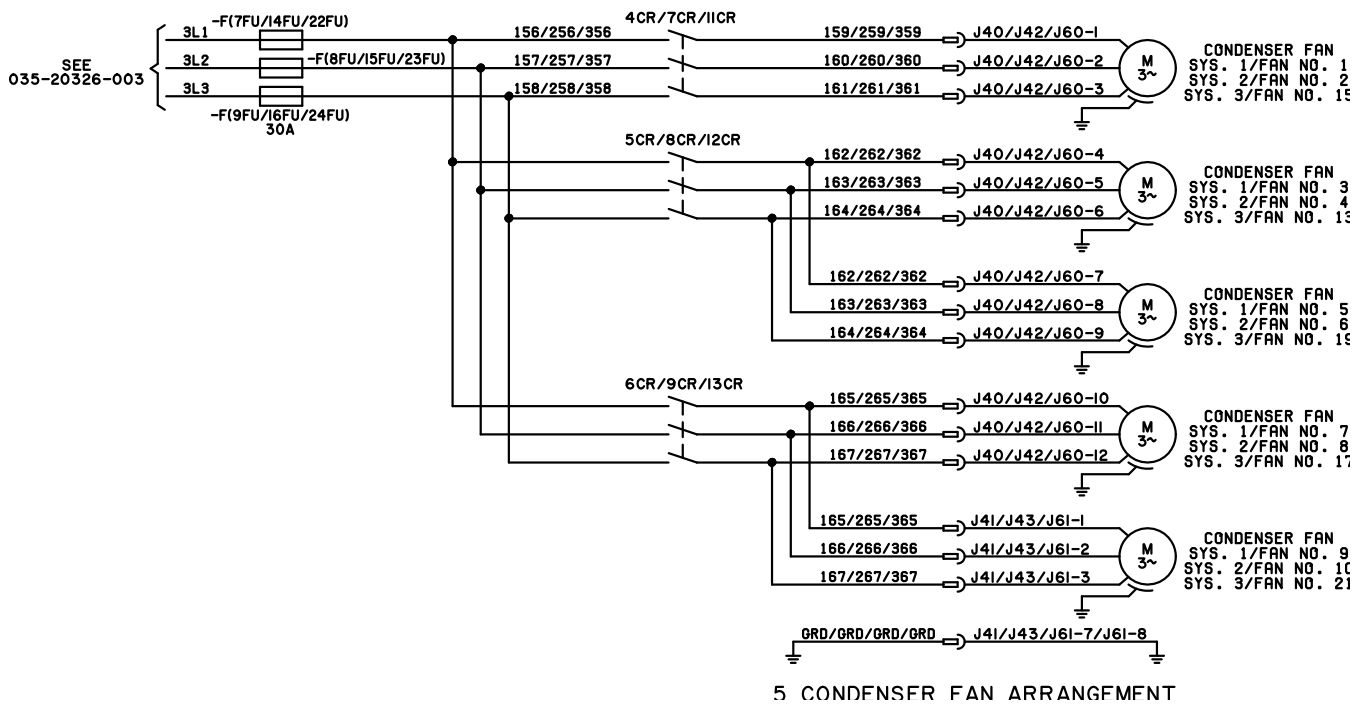
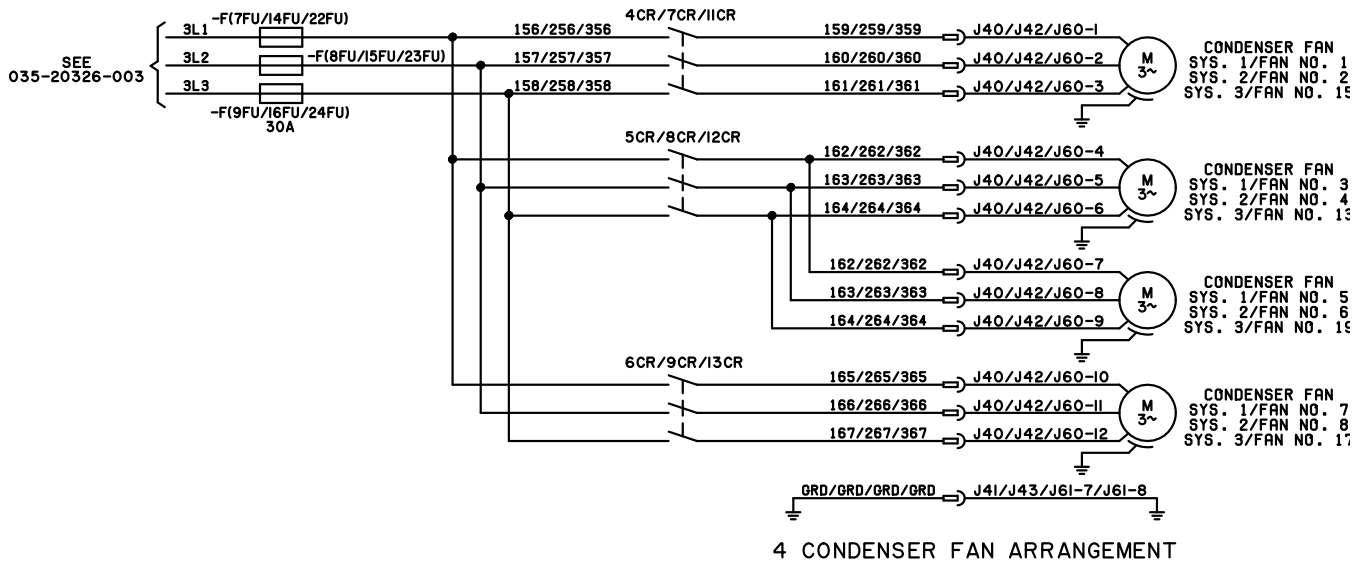

LD13097

FIG. 20 - POWER ELEMENTARY DIAGRAM - YCIV1050-1500 3 COMPRESSOR MODELS

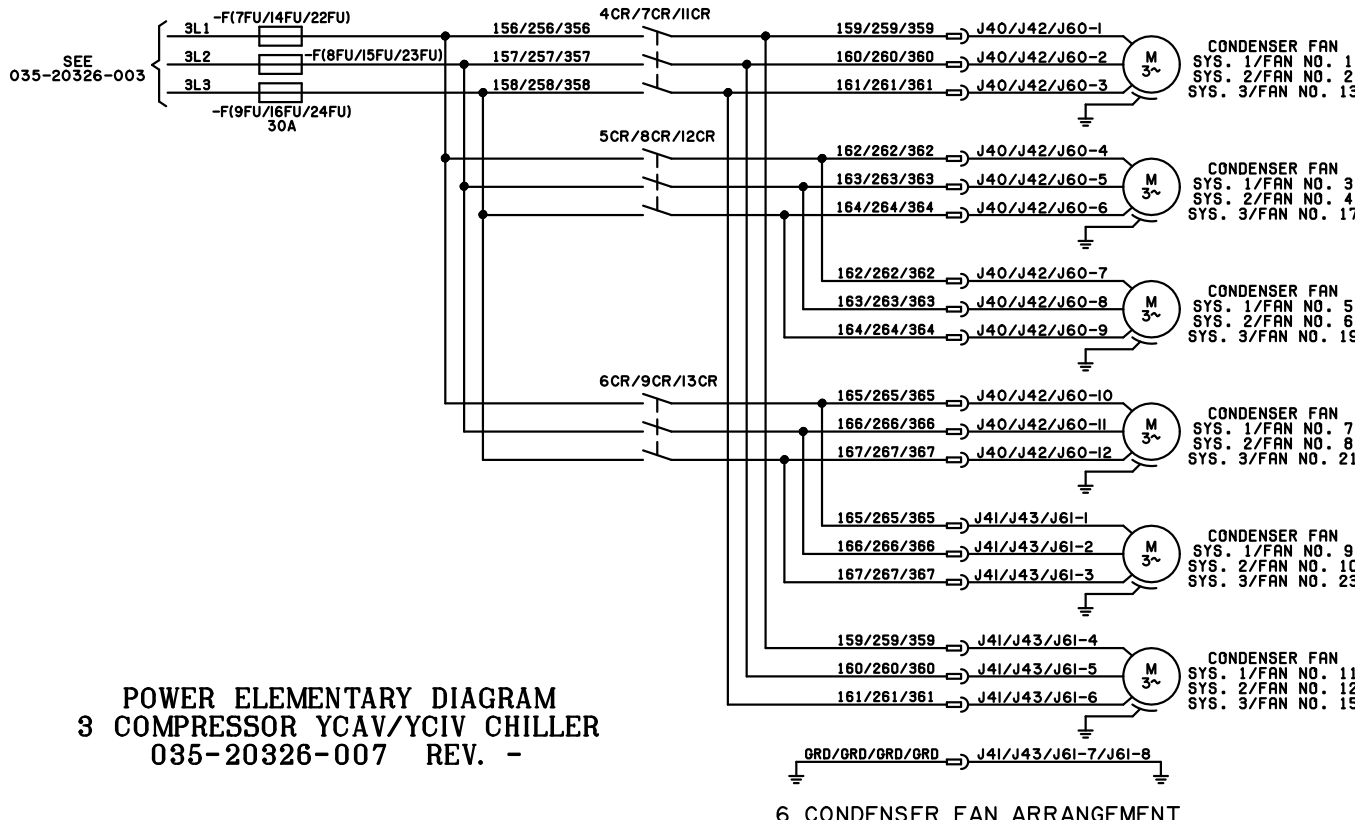

POWER ELEMENTARY DIAGRAM  
3 COMPRESSOR YCAV/YCIV CHILLER  
035-20326-007 REV. -

6

LD13098

FIG. 20 - POWER ELEMENTARY DIAGRAM - YCIV1050-1500 3 COMPRESSOR MODELS (CONT'D)

### LOCATION LABEL - YCIV1050-1500 3 COMPRESSOR MODELS

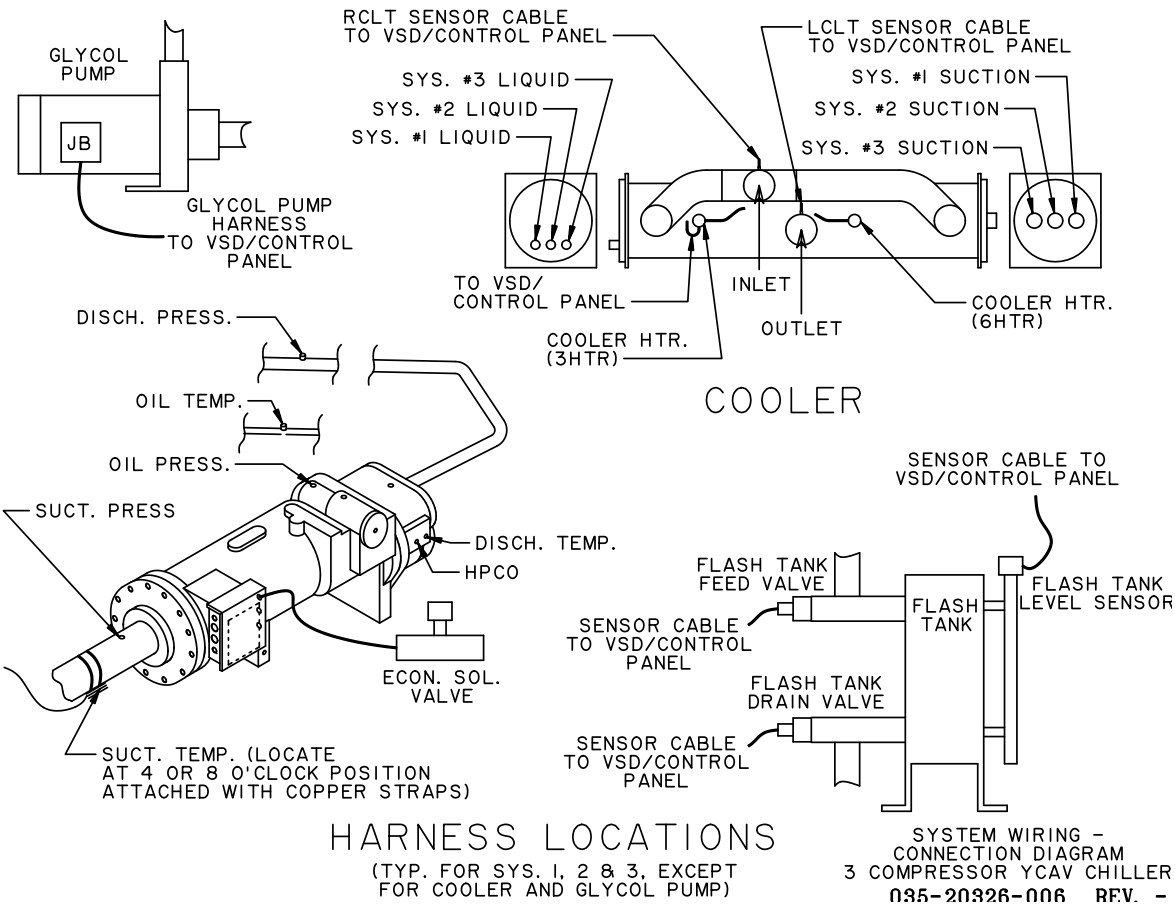
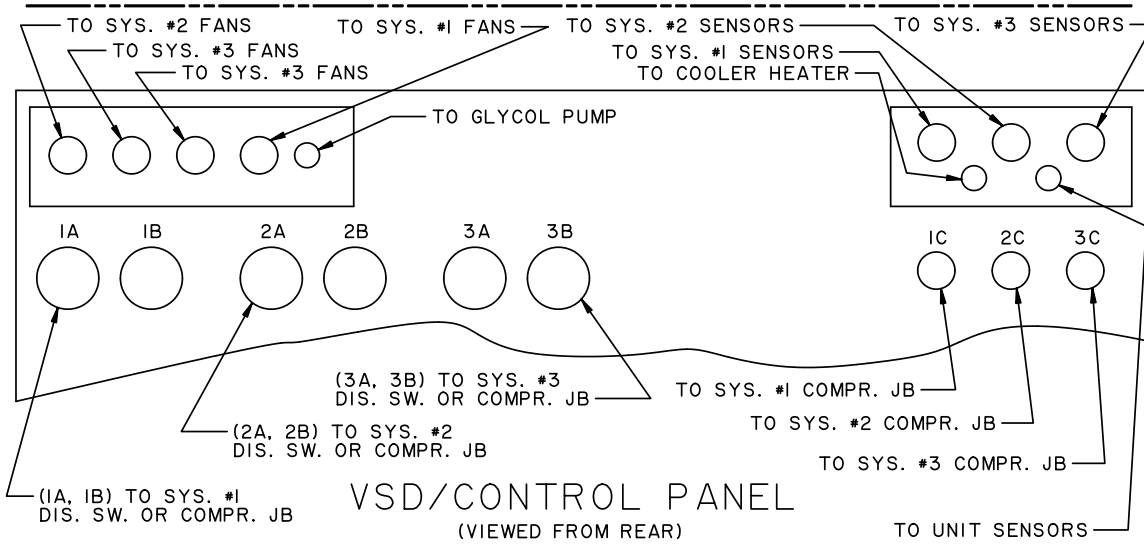
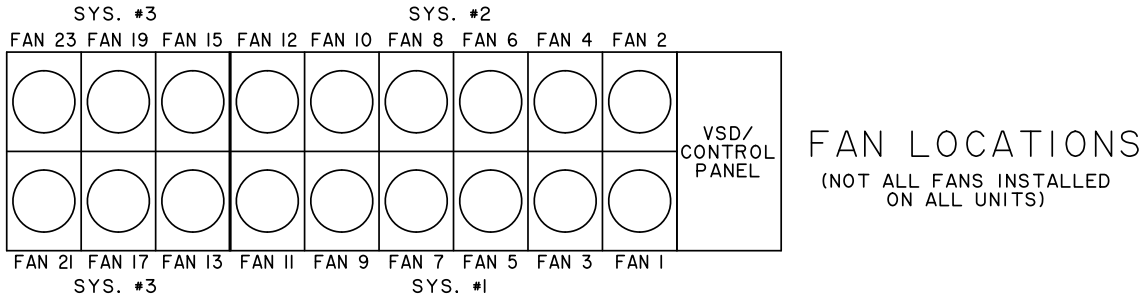

SYSTEM WIRING - CONNECTION DIAGRAM  
3 COMPRESSOR YCAV CHILLER  
035-20326-006 REV. -

# PANEL LAYOUT - YCIV1050-1500 3 COMPRESSOR MODELS

PANEL LAYOUT  
 3 COMPRESSOR YCAV/YCIV CHILLER  
 035-20326-008 REV. -

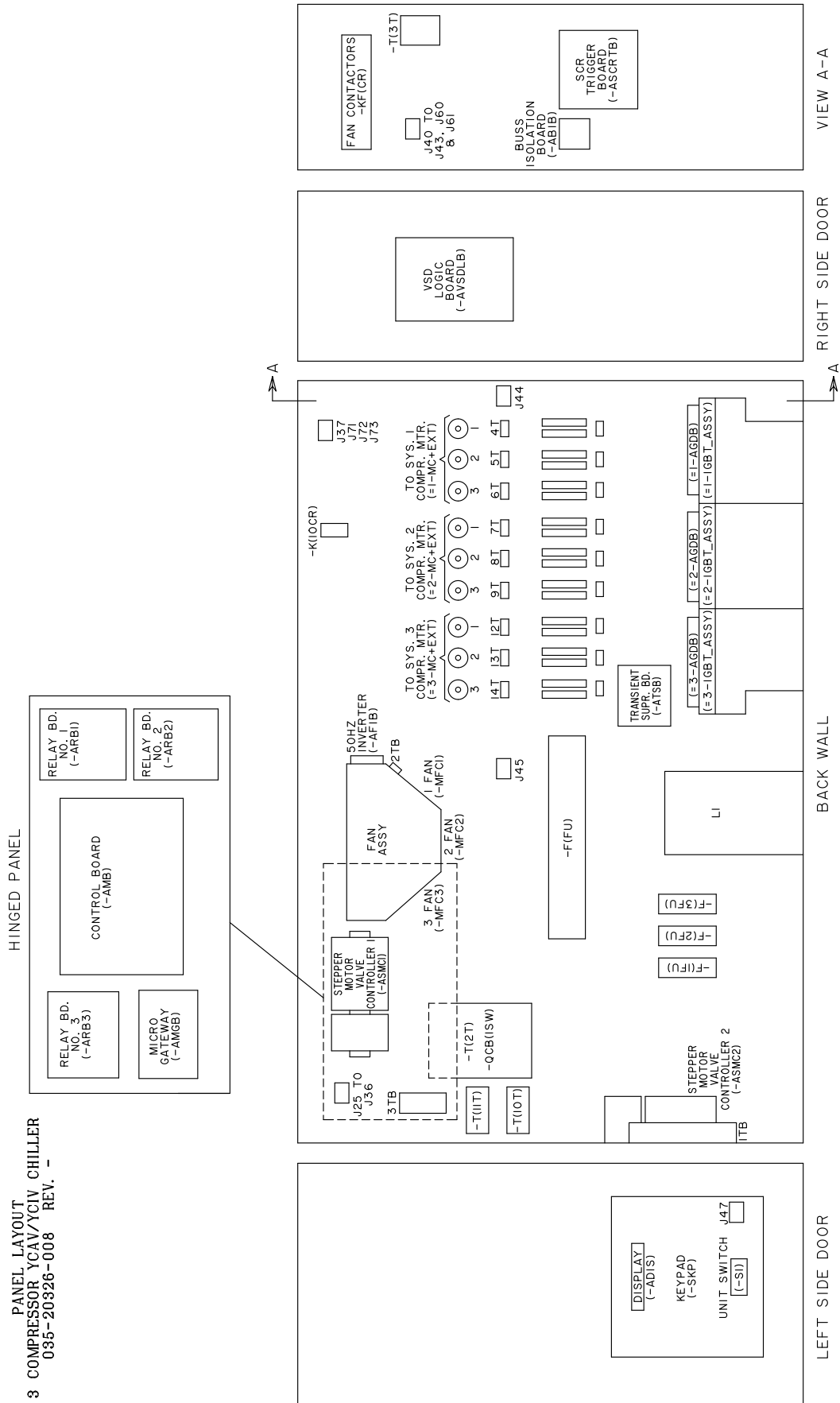

## DIMENSIONS - 2 AND 3 COMPRESSOR SI

### YCIV0590E/V and YCIV0600S/P

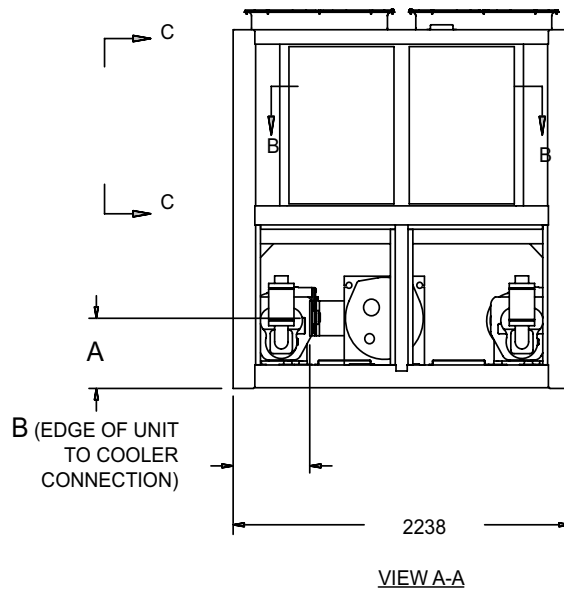
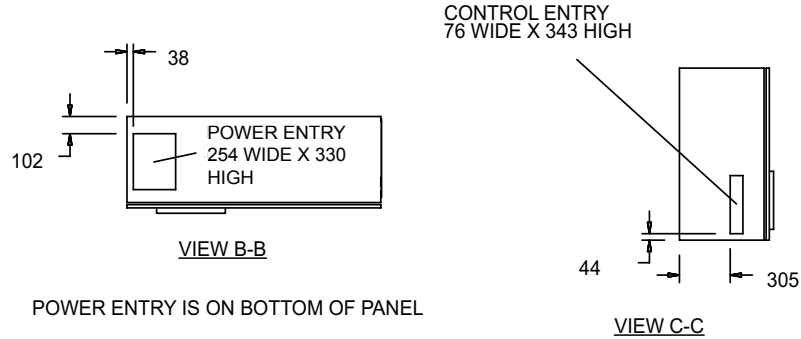

YCIV	A	B	C	D
0590E/V	485	714	2146	2865
0600S/P	442	739	2286	2797

**NOTE:**

Placement on a level surface of free of obstructions (including snow, for winter operation) or air circulation ensures rated performance, reliable operation, and ease of maintenance. Site restrictions may compromise minimum clearances indicated below, resulting in unpredictable airflow patterns and possible diminished performance. Johnson Controls unit controls will optimize operation without nuisance high-pressure safety cutouts; however, the

system designer must consider potential performance degradation. Access to the unit control center assumes the unit is no higher than on spring isolators. Recommended minimum clearances: side to wall – 2m; rear to wall – 2m; control panel to end wall – 1.2m; top – no obstructions whatsoever; distance between adjacent units – 3m. No more than one adjacent wall may be higher than the unit.

## DIMENSIONS - 2 AND 3 COMPRESSOR SI (CONT'D)

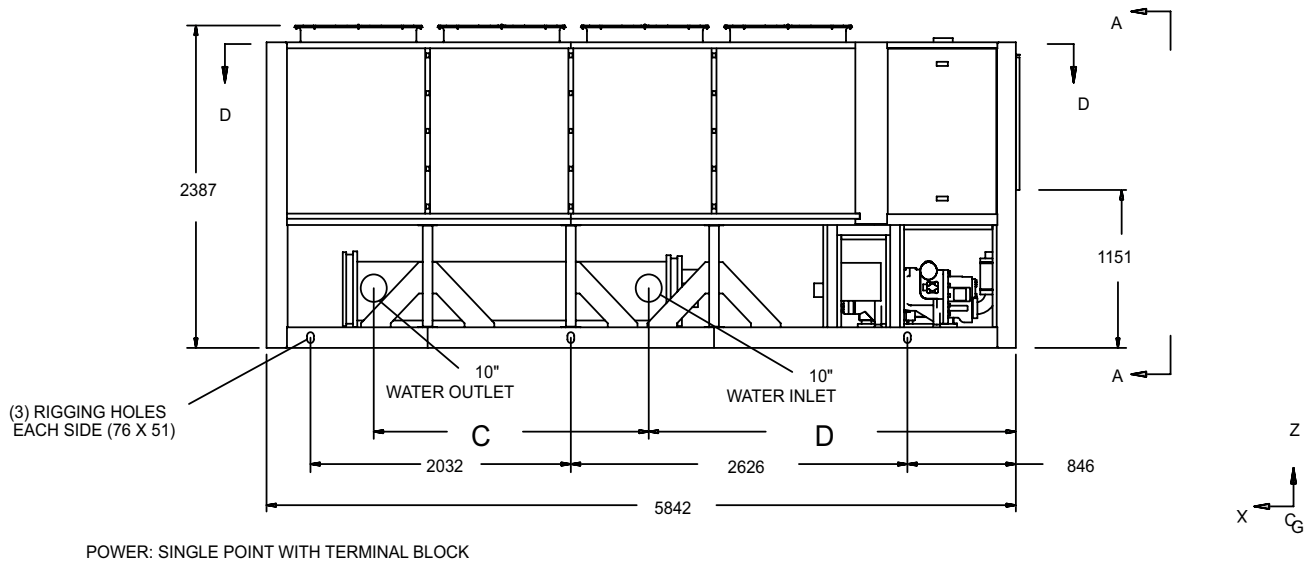
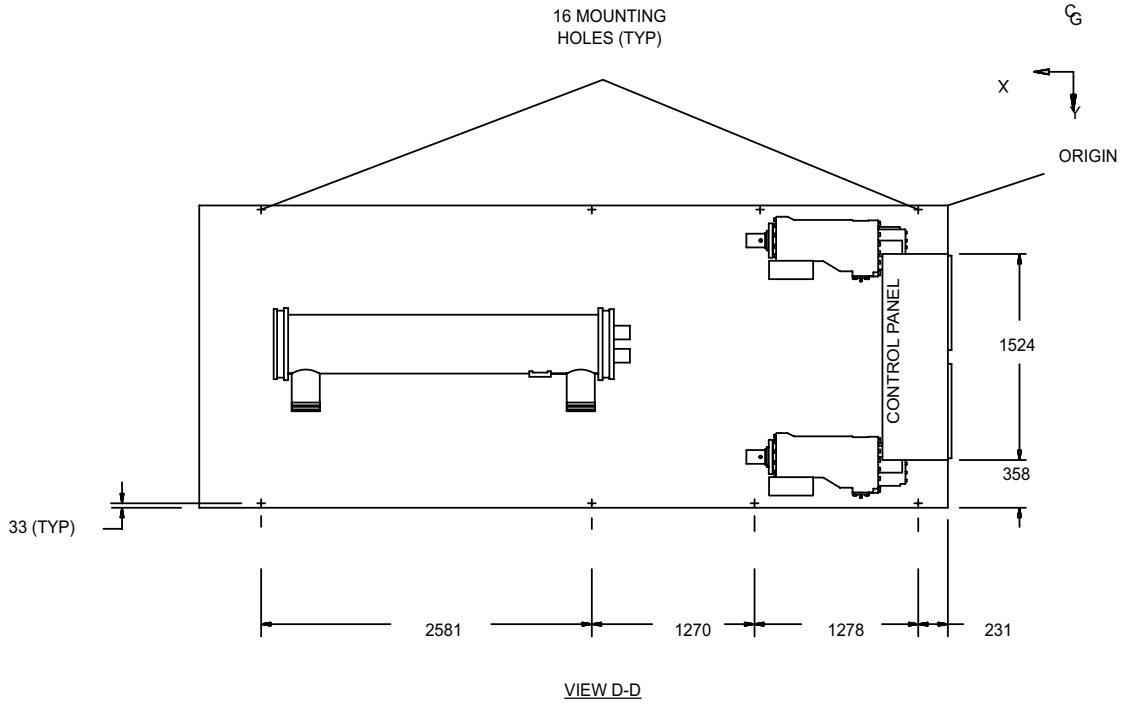

**DIMENSIONS - 2 AND 3 COMPRESSOR SI (CONT'D)**

**YCIV0630E/V, YCIV0650S/P, YCIV0700E/V and YCIV0720S/P**

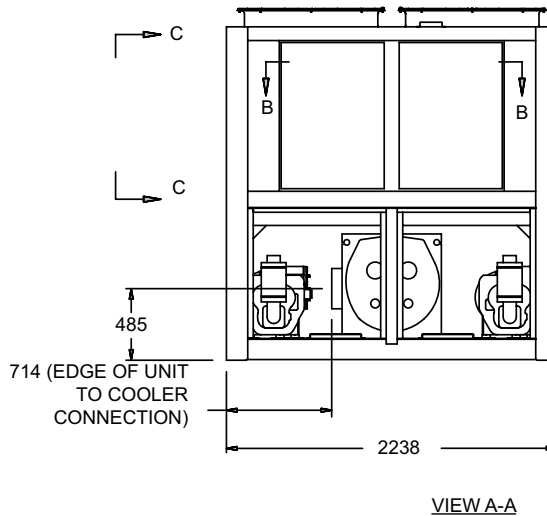
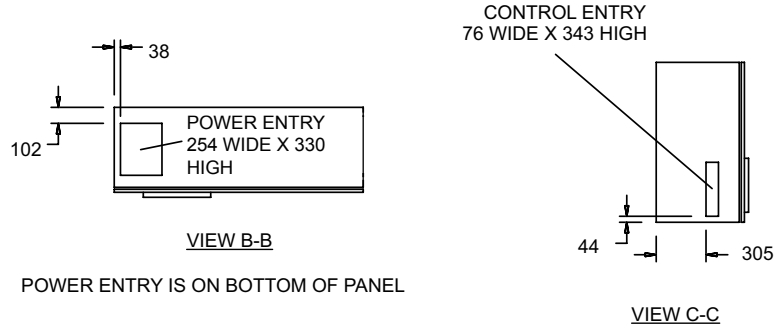

YCIV	A	B
06307E/V	2238	6960
0650S/P	2032	5842
0700E/V	2238	6960
0720S/P	2238	6960

**NOTE:**

Placement on a level surface of free of obstructions (including snow, for winter operation) or air circulation ensures rated performance, reliable operation, and ease of maintenance. Site restrictions may compromise minimum clearances indicated below, resulting in unpredictable airflow patterns and possible diminished performance. Johnson Controls unit controls will optimize operation without nuisance high-pressure safety cutouts; however, the

system designer must consider potential performance degradation. Access to the unit control center assumes the unit is no higher than on spring isolators. Recommended minimum clearances: side to wall – 2m; rear to wall – 2m; control panel to end wall – 1.2m; top – no obstructions whatsoever; distance between adjacent units – 3m. No more than one adjacent wall may be higher than the unit.

## DIMENSIONS - 2 AND 3 COMPRESSOR SI (CONT'D)

DIMENSIONS (mm) UNLESS OTHERWISE NOTED

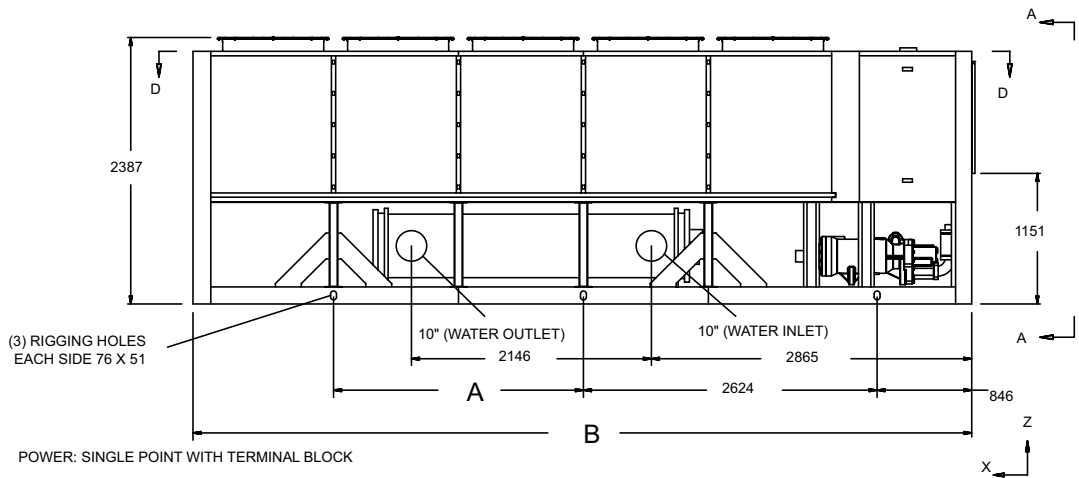
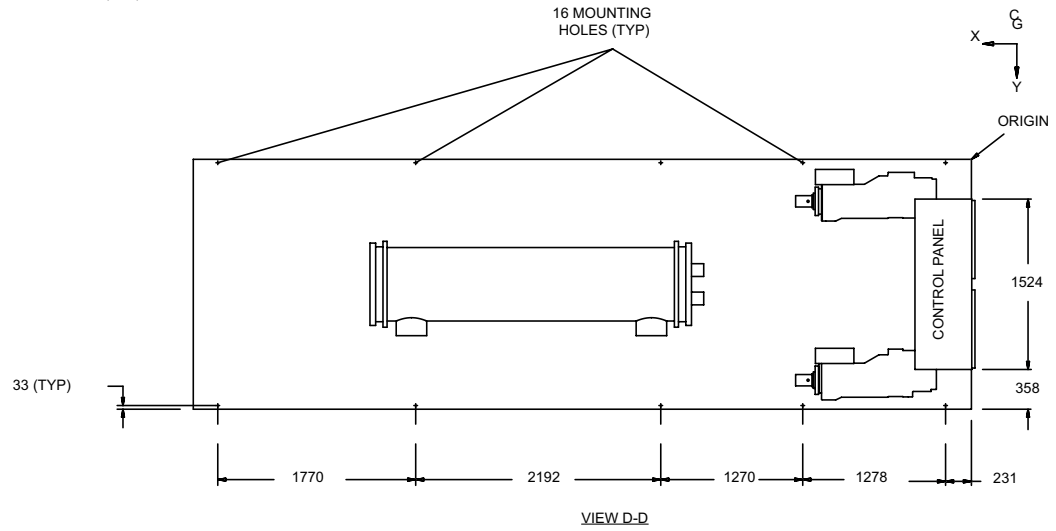

6

**DIMENSIONS - 2 AND 3 COMPRESSOR SI (CONT'D)**

**YCIV0760E/V and YCIV0770S/P**

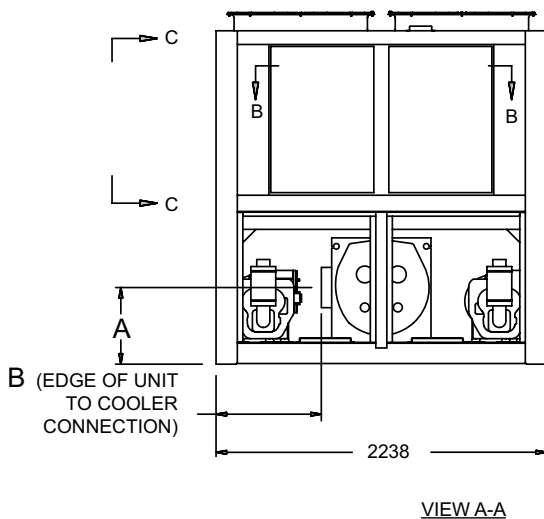
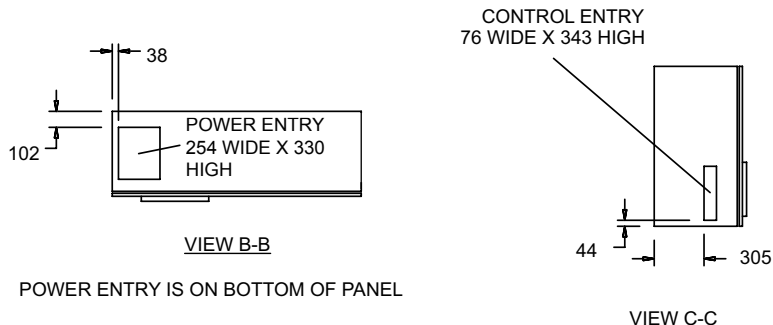

YCIV	A	B	C	D
0760E/V	518	714	2174	2852
0770S/P	564	660	2009	2878
0890S/P	564	660	2009	2878

**NOTE:**

Placement on a level surface of free of obstructions (including snow, for winter operation) or air circulation ensures rated performance, reliable operation, and ease of maintenance. Site restrictions may compromise minimum clearances indicated below, resulting in unpredictable airflow patterns and possible diminished performance. Johnson Controls unit controls will optimize operation without nuisance high-pressure safety cutouts; however, the

system designer must consider potential performance degradation. Access to the unit control center assumes the unit is no higher than on spring isolators. Recommended minimum clearances: side to wall – 2m; rear to wall – 2m; control panel to end wall – 1.2m; top – no obstructions whatsoever; distance between adjacent units – 3m. No more than one adjacent wall may be higher than the unit.

## DIMENSIONS - 2 AND 3 COMPRESSOR SI (CONT'D)

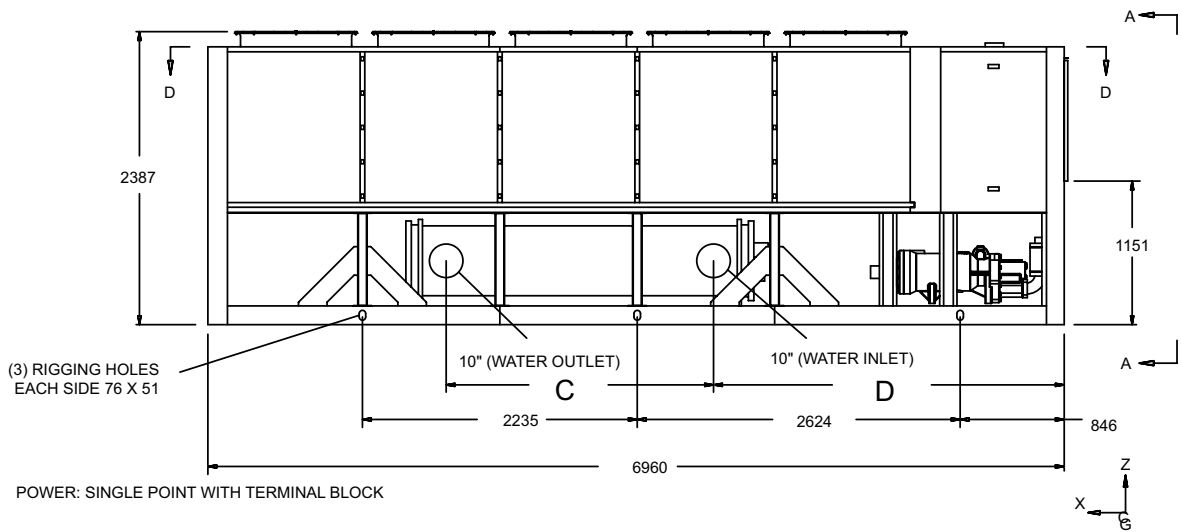
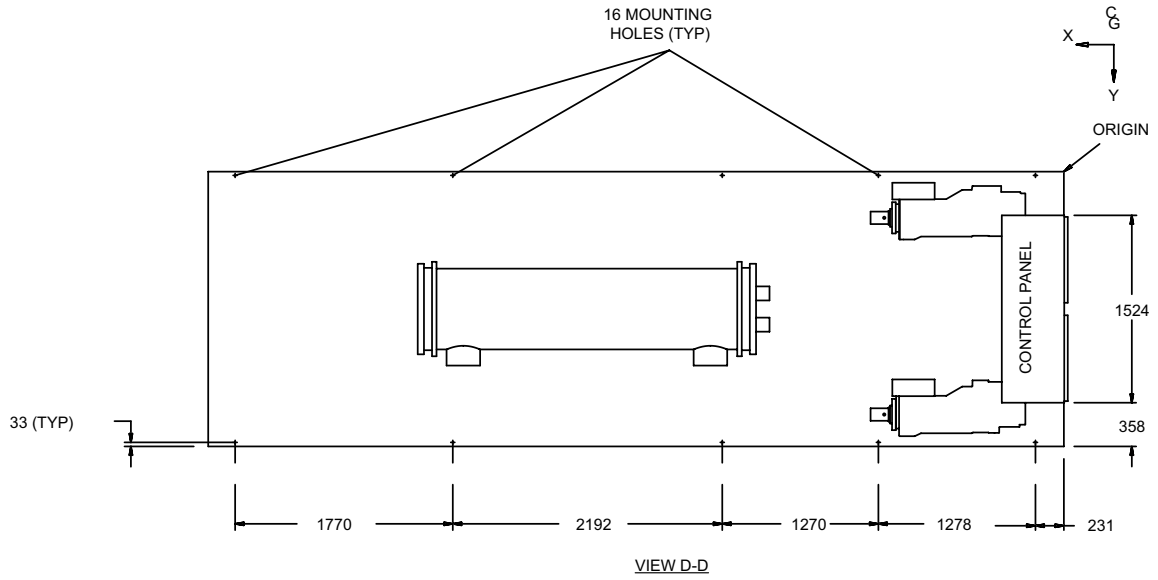

**DIMENSIONS - 2 AND 3 COMPRESSOR SI (CONT'D)**

**YCIV0800E/V and YCIV0830E/V**

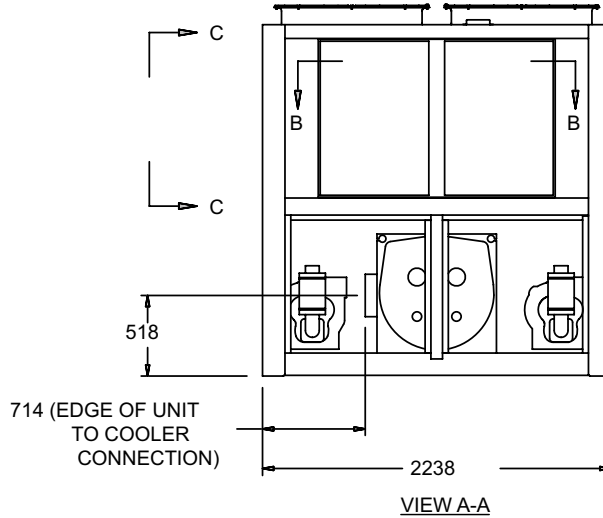
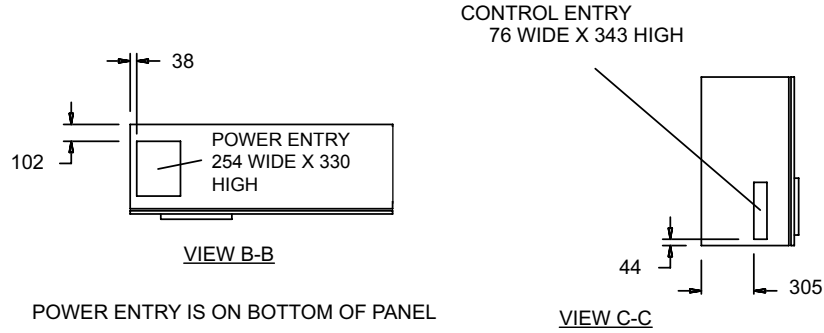

**NOTE:**

Placement on a level surface of free of obstructions (including snow, for winter operation) or air circulation ensures rated performance, reliable operation, and ease of maintenance. Site restrictions may compromise minimum clearances indicated below, resulting in unpredictable airflow patterns and possible diminished performance. Johnson Controls unit controls will optimize operation without nuisance high-pressure safety cutouts; however, the

system designer must consider potential performance degradation. Access to the unit control center assumes the unit is no higher than on spring isolators. Recommended minimum clearances: side to wall – 2m; rear to wall – 2m; control panel to end wall – 1.2m; top – no obstructions whatsoever; distance between adjacent units – 3m. No more than one adjacent wall may be higher than the unit.

# DIMENSIONS - 2 AND 3 COMPRESSOR SI (CONT'D)

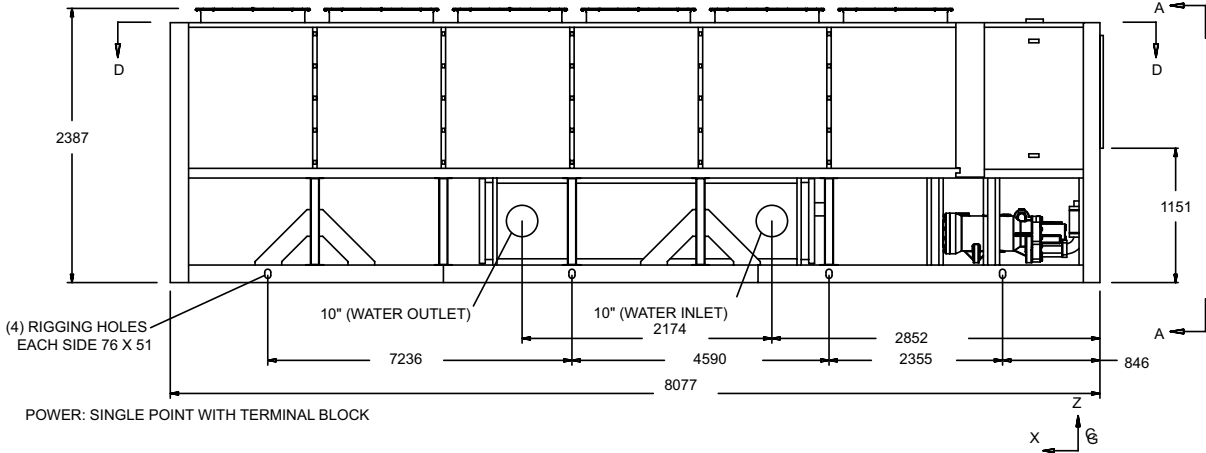
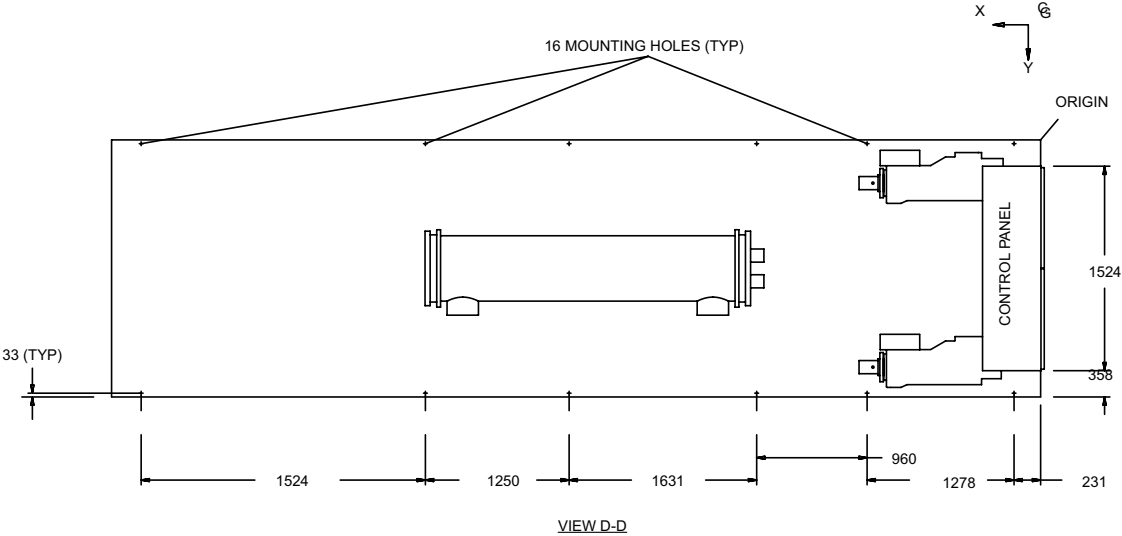

**DIMENSIONS - 2 AND 3 COMPRESSOR SI (CONT'D)**

**YCIV0920S/P, YCIV0930E/V, and YCIV1000S/P**

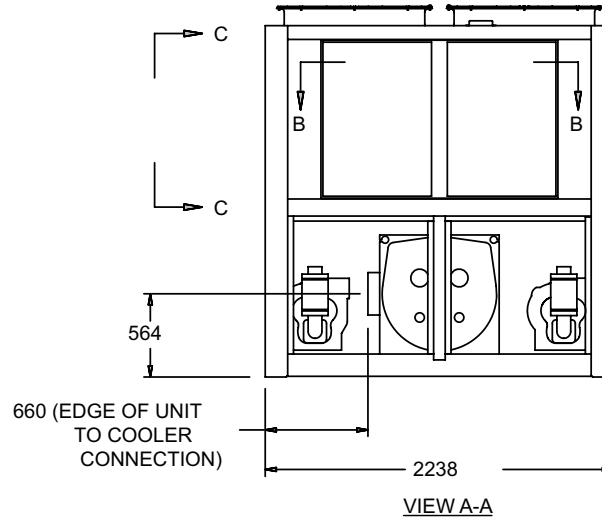
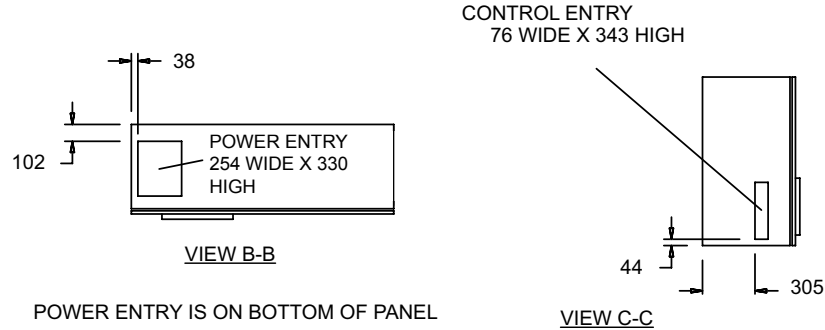

**NOTE:**

Placement on a level surface of free of obstructions (including snow, for winter operation) or air circulation ensures rated performance, reliable operation, and ease of maintenance. Site restrictions may compromise minimum clearances indicated below, resulting in unpredictable airflow patterns and possible diminished performance. Johnson Controls unit controls will optimize operation without nuisance high-pressure safety cutouts; however, the

system designer must consider potential performance degradation. Access to the unit control center assumes the unit is no higher than on spring isolators. Recommended minimum clearances: side to wall – 2m; rear to wall – 2m; control panel to end wall – 1.2m; top – no obstructions whatsoever; distance between adjacent units – 3m. No more than one adjacent wall may be higher than the unit.

## DIMENSIONS - 2 AND 3 COMPRESSOR SI (CONT'D)

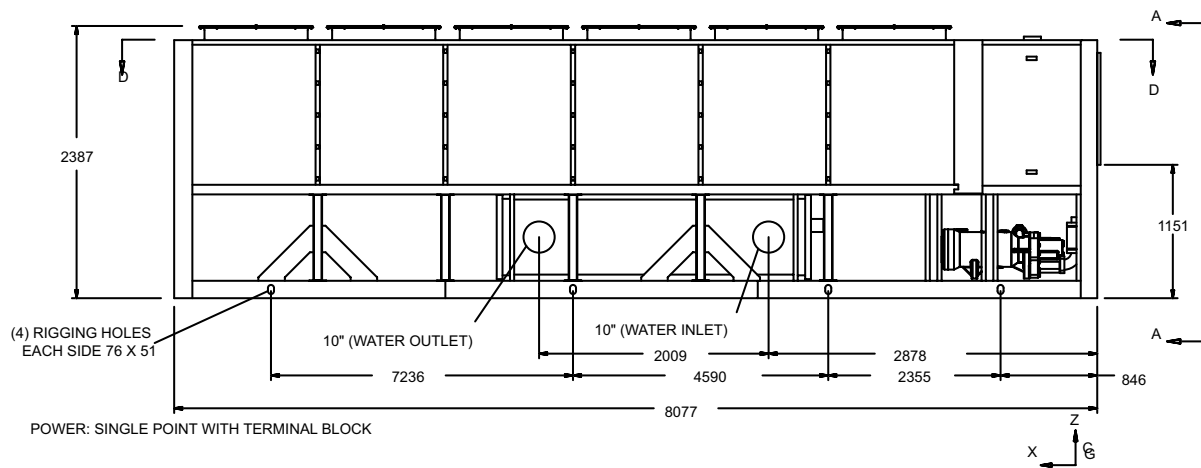
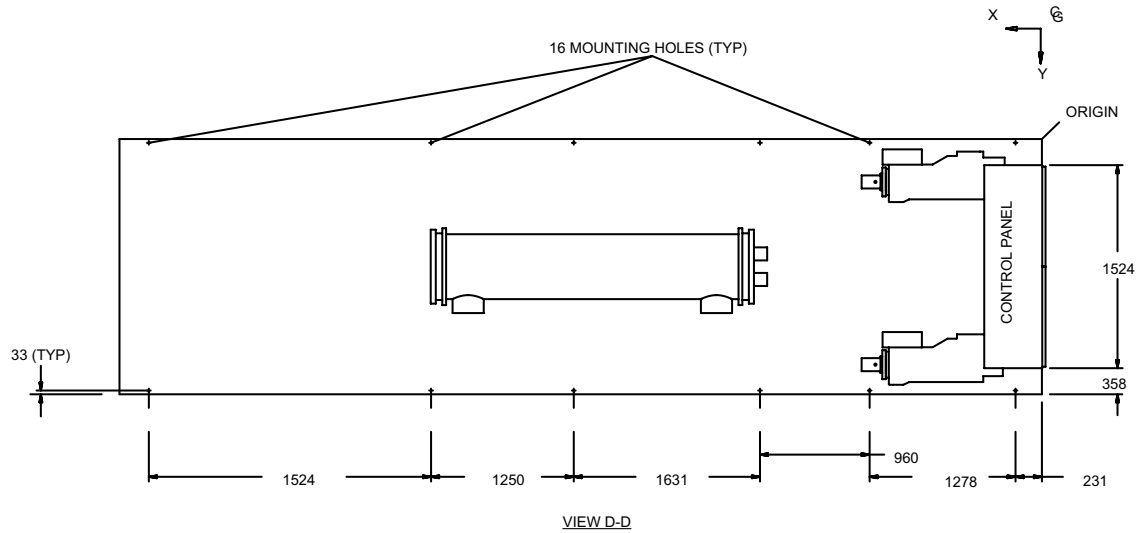

6

**DIMENSIONS - 2 AND 3 COMPRESSOR SI (CONT'D)**

**YCIV1050E/V and YCIV1070S/P**

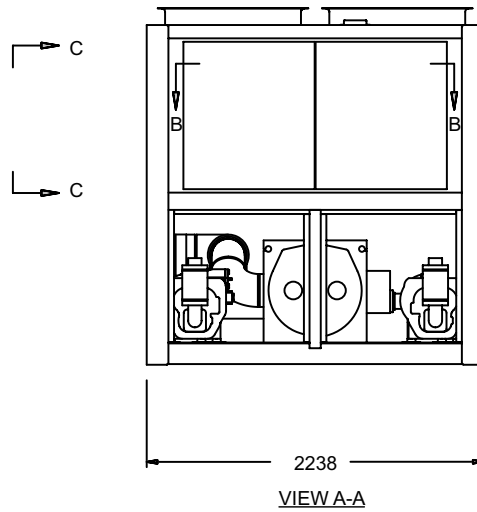
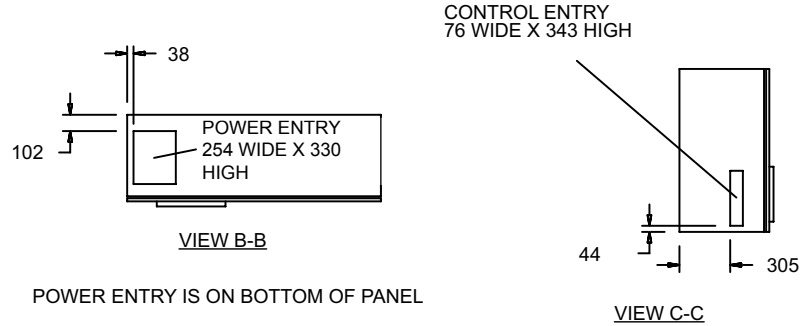

**NOTE:**

Placement on a level surface of free of obstructions (including snow, for winter operation) or air circulation ensures rated performance, reliable operation, and ease of maintenance. Site restrictions may compromise minimum clearances indicated below, resulting in unpredictable airflow patterns and possible diminished performance. Johnson Controls unit controls will optimize operation without nuisance high-pressure safety cutouts; however, the

system designer must consider potential performance degradation. Access to the unit control center assumes the unit is no higher than on spring isolators. Recommended minimum clearances: side to wall – 2m; rear to wall – 2m; control panel to end wall – 1.2m; top – no obstructions whatsoever; distance between adjacent units – 3m. No more than one adjacent wall may be higher than the unit.

# DIMENSIONS - 2 AND 3 COMPRESSOR SI (CONT'D)

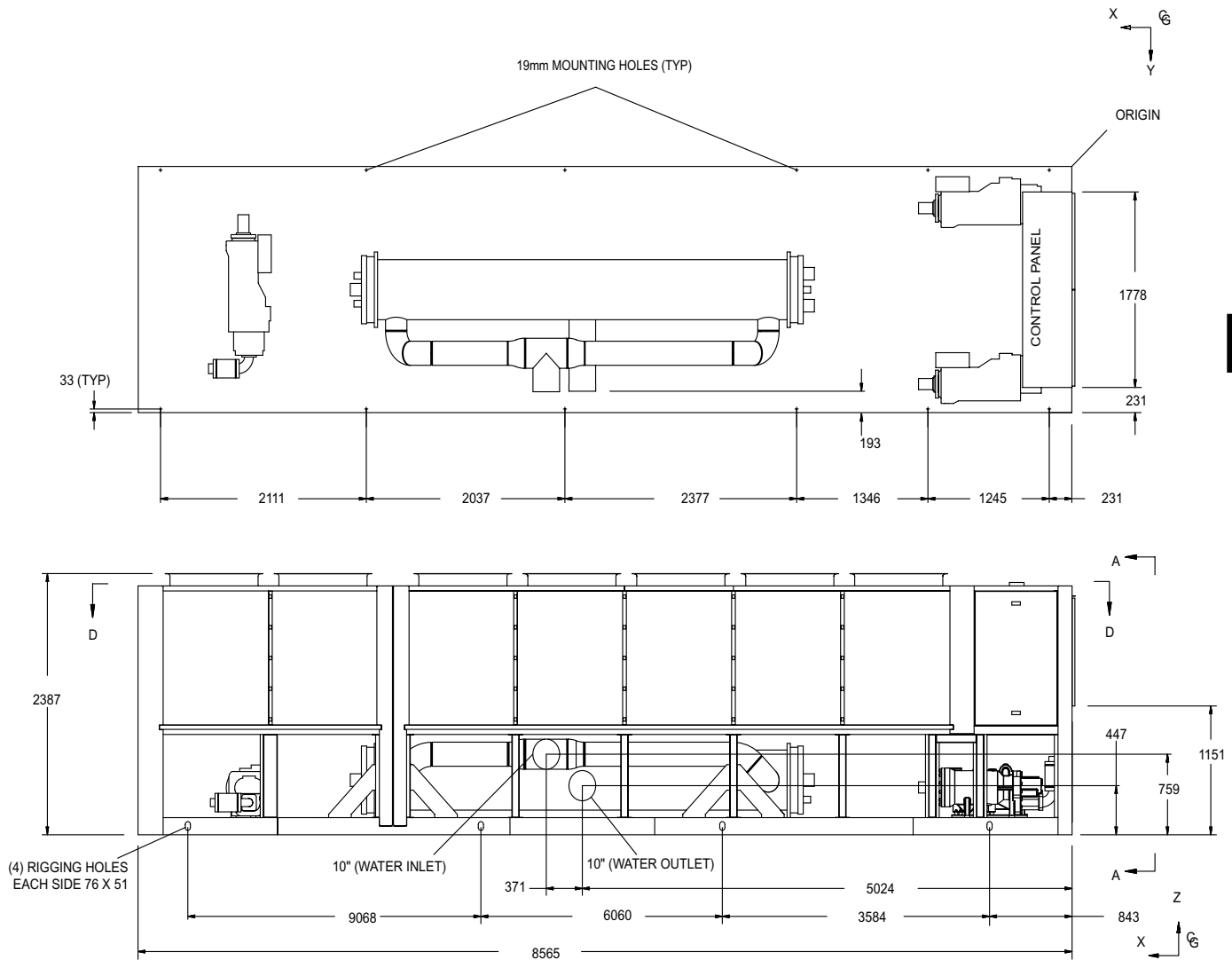

6

LD 13663

**DIMENSIONS - 2 AND 3 COMPRESSOR SI (CONT'D)**

**YCIV1120E/V**

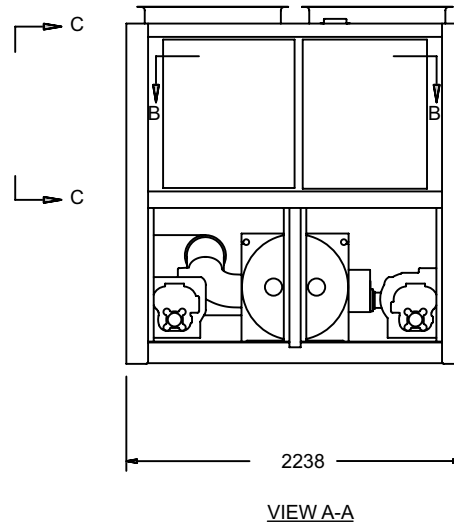
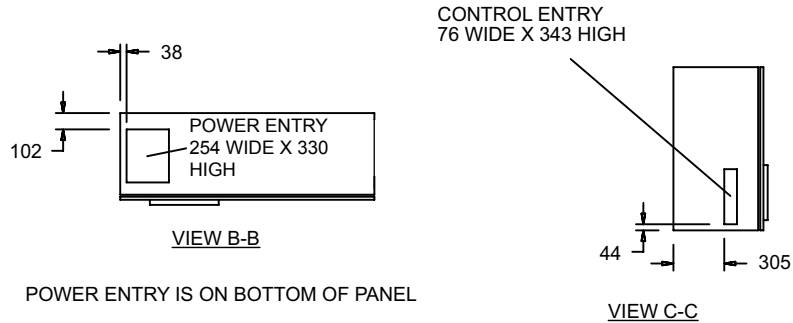

**NOTE:**

Placement on a level surface of free of obstructions (including snow, for winter operation) or air circulation ensures rated performance, reliable operation, and ease of maintenance. Site restrictions may compromise minimum clearances indicated below, resulting in unpredictable airflow patterns and possible diminished performance. Johnson Controls unit controls will optimize operation without nuisance high-pressure safety cutouts; however, the

system designer must consider potential performance degradation. Access to the unit control center assumes the unit is no higher than on spring isolators. Recommended minimum clearances: side to wall – 2m; rear to wall – 2m; control panel to end wall – 1.2m; top – no obstructions whatsoever; distance between adjacent units – 3m. No more than one adjacent wall may be higher than the unit.

# DIMENSIONS - 2 AND 3 COMPRESSOR SI (CONT'D)

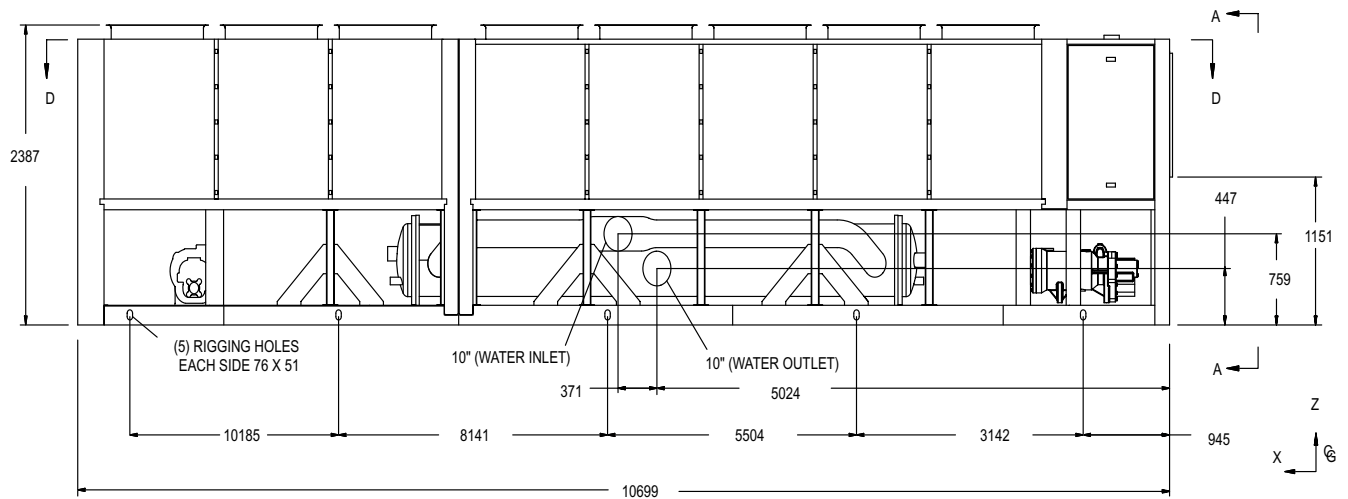
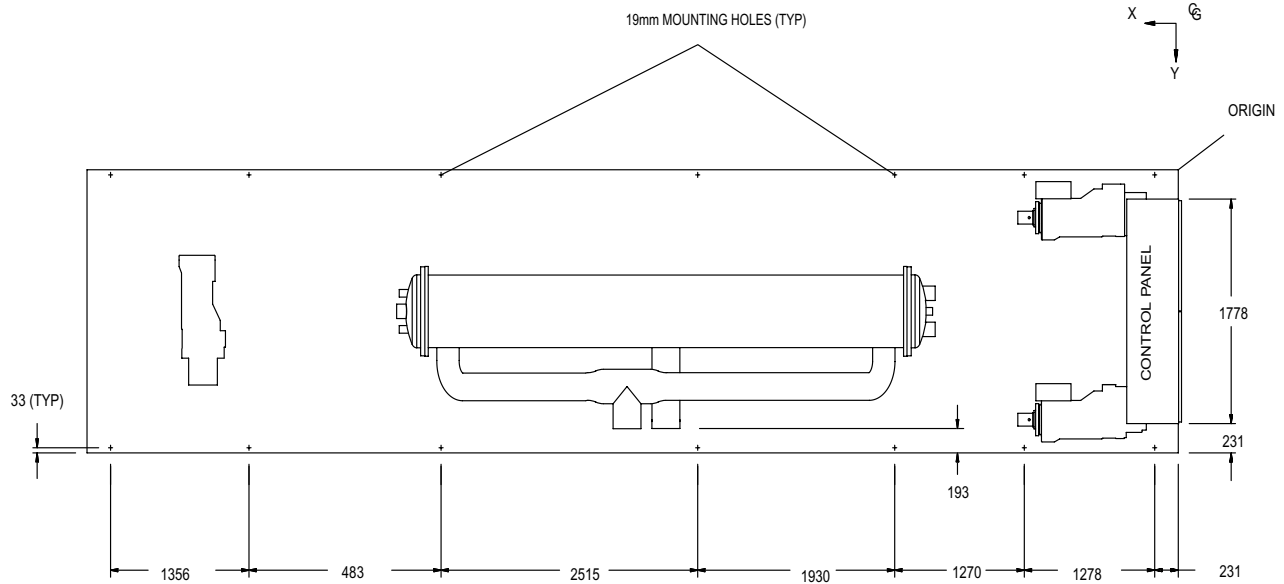

6

**DIMENSIONS - 2 AND 3 COMPRESSOR SI (CONT'D)**

**YCIV1180S/P**

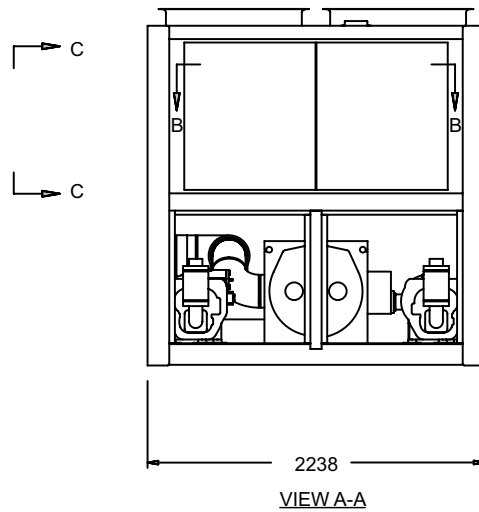
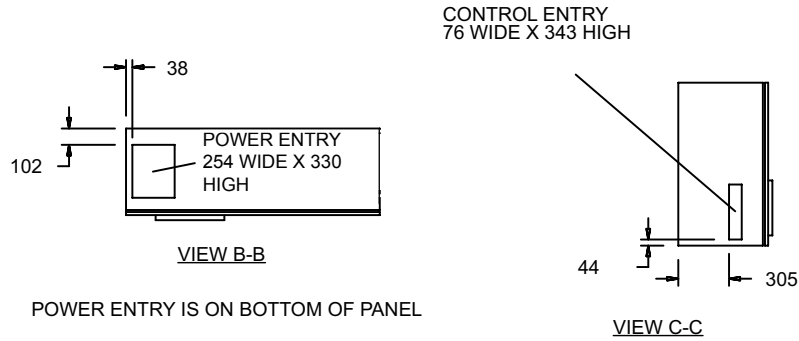

**NOTE:**

Placement on a level surface of free of obstructions (including snow, for winter operation) or air circulation ensures rated performance, reliable operation, and ease of maintenance. Site restrictions may compromise minimum clearances indicated below, resulting in unpredictable airflow patterns and possible diminished performance. Johnson Controls unit controls will optimize operation without nuisance high-pressure safety cutouts; however, the

system designer must consider potential performance degradation. Access to the unit control center assumes the unit is no higher than on spring isolators. Recommended minimum clearances: side to wall – 2m; rear to wall – 2m; control panel to end wall – 1.2m; top – no obstructions whatsoever; distance between adjacent units – 3m. No more than one adjacent wall may be higher than the unit.

## DIMENSIONS - 2 AND 3 COMPRESSOR SI (CONT'D)

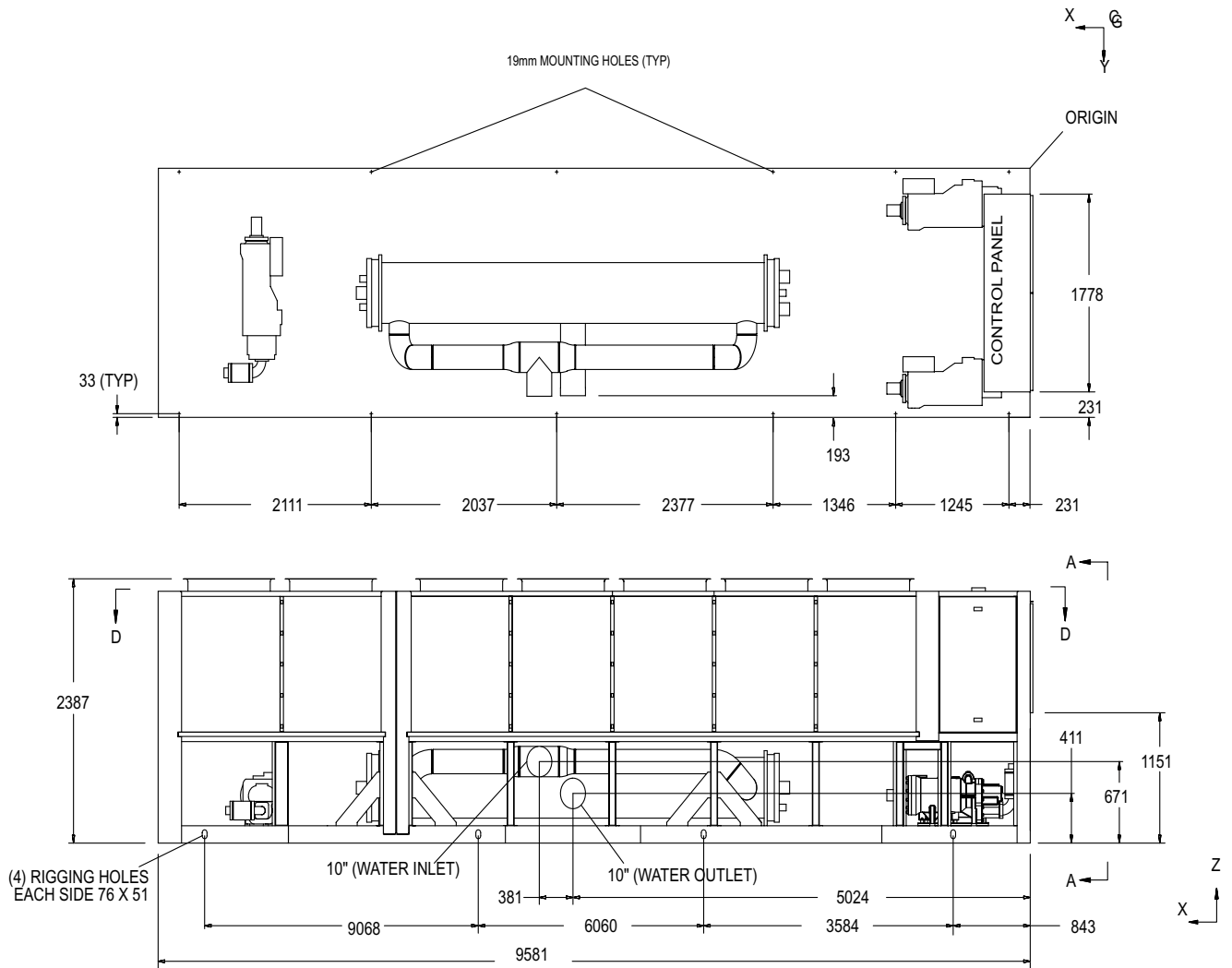

6

LD 13665

**DIMENSIONS - 2 AND 3 COMPRESSOR SI (CONT'D)**

**YCIV1220E/V and YCIV1340S/P**

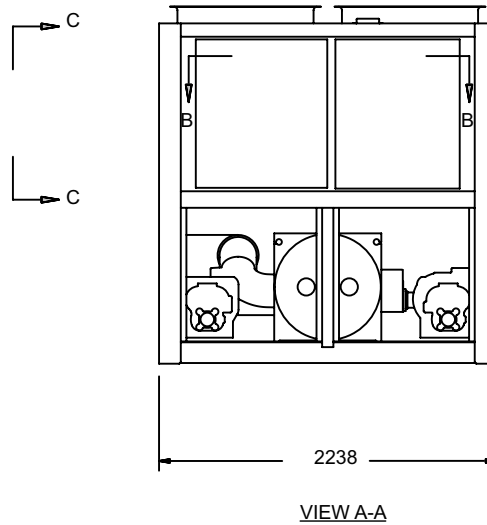
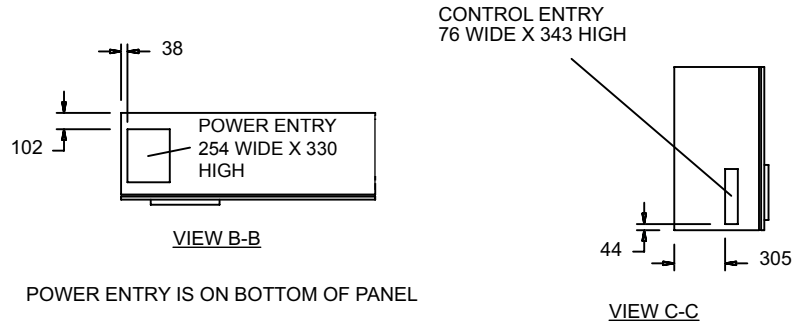

**NOTE:**

Placement on a level surface of free of obstructions (including snow, for winter operation) or air circulation ensures rated performance, reliable operation, and ease of maintenance. Site restrictions may compromise minimum clearances indicated below, resulting in unpredictable airflow patterns and possible diminished performance. Johnson Controls unit controls will optimize operation without nuisance high-pressure safety cutouts; however, the

system designer must consider potential performance degradation. Access to the unit control center assumes the unit is no higher than on spring isolators. Recommended minimum clearances: side to wall – 2m; rear to wall – 2m; control panel to end wall – 1.2m; top – no obstructions whatsoever; distance between adjacent units – 3m. No more than one adjacent wall may be higher than the unit.

## DIMENSIONS - 2 AND 3 COMPRESSOR SI (CONT'D)

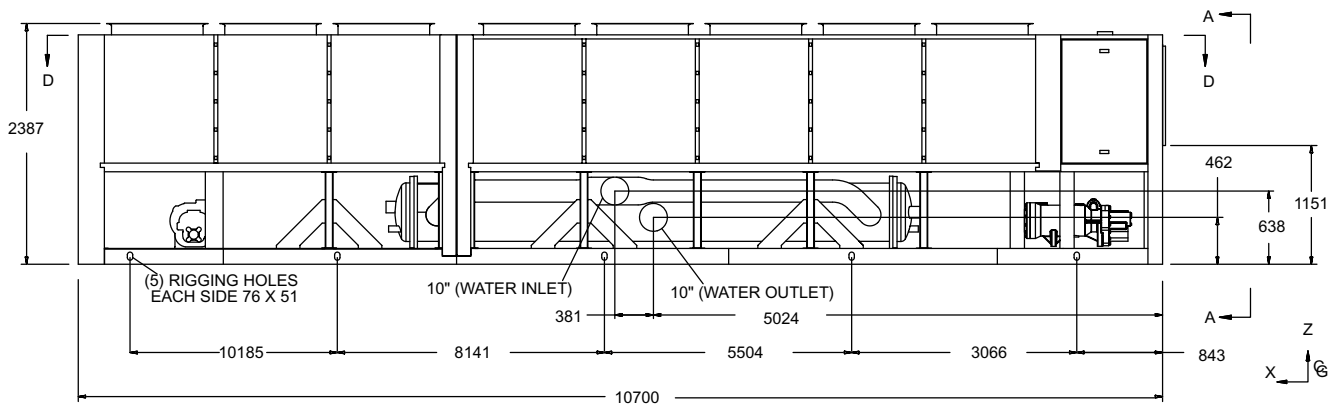
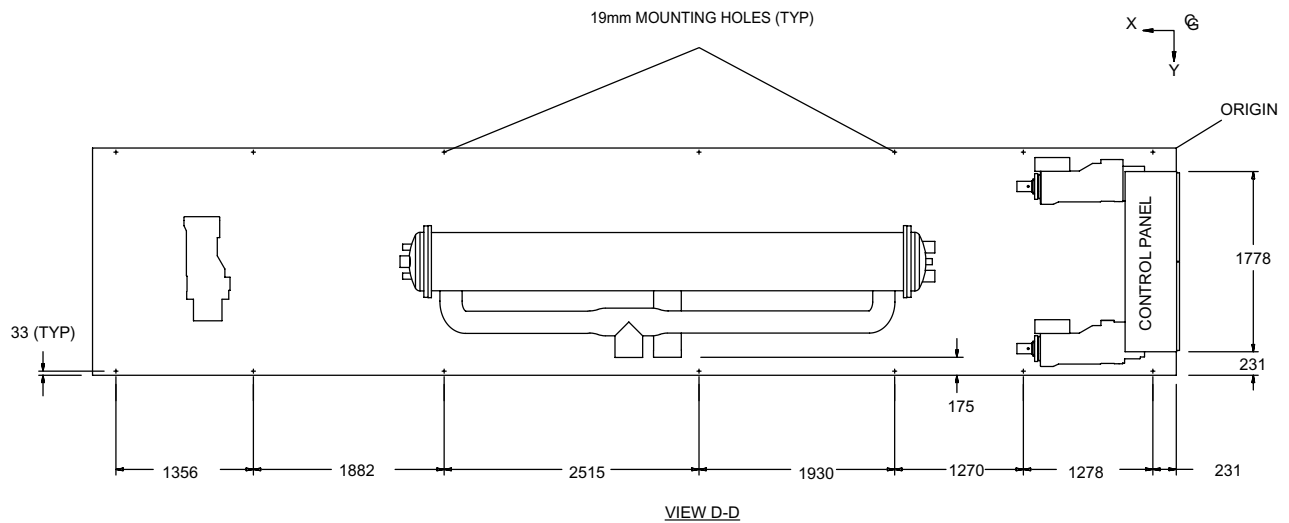

LD 13666

## DIMENSIONS - 2 AND 3 COMPRESSOR SI (CONT'D)

### YCIV1380E/V and YCIV1500S/P

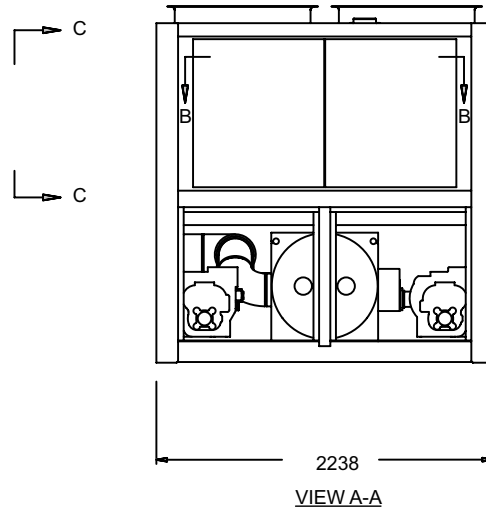
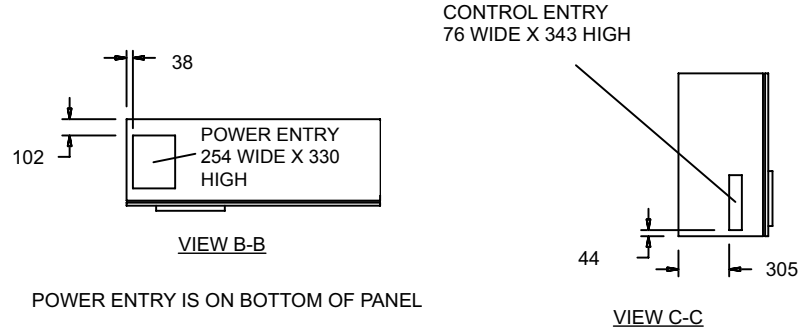

**NOTE:**

Placement on a level surface of free of obstructions (including snow, for winter operation) or air circulation ensures rated performance, reliable operation, and ease of maintenance. Site restrictions may compromise minimum clearances indicated below, resulting in unpredictable airflow patterns and possible diminished performance. Johnson Controls unit controls will optimize operation without nuisance high-pressure safety cutouts; however, the

system designer must consider potential performance degradation. Access to the unit control center assumes the unit is no higher than on spring isolators. Recommended minimum clearances: side to wall – 2m; rear to wall – 2m; control panel to end wall – 1.2m; top – no obstructions whatsoever; distance between adjacent units – 3m. No more than one adjacent wall may be higher than the unit.

## DIMENSIONS - 2 AND 3 COMPRESSOR SI (CONT'D)

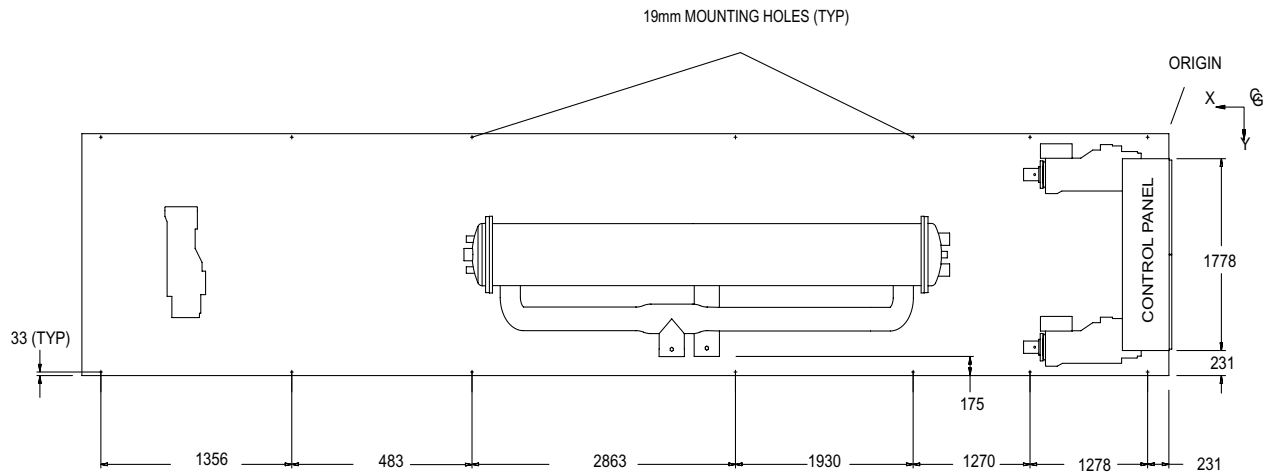

VIEW D-D

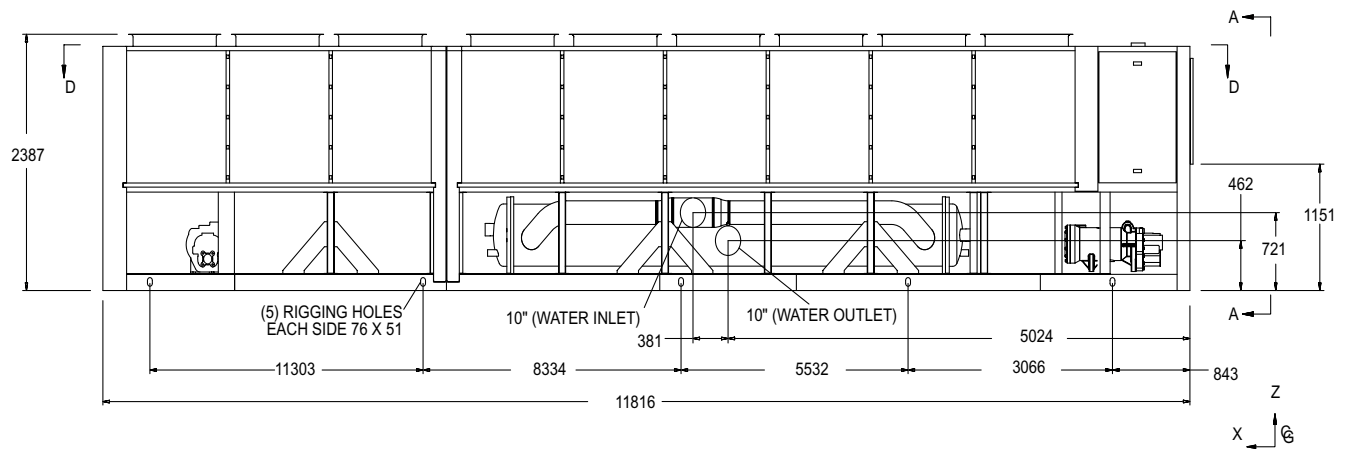

LD 13667

6

TECHNICAL DATA - CLEARANCES

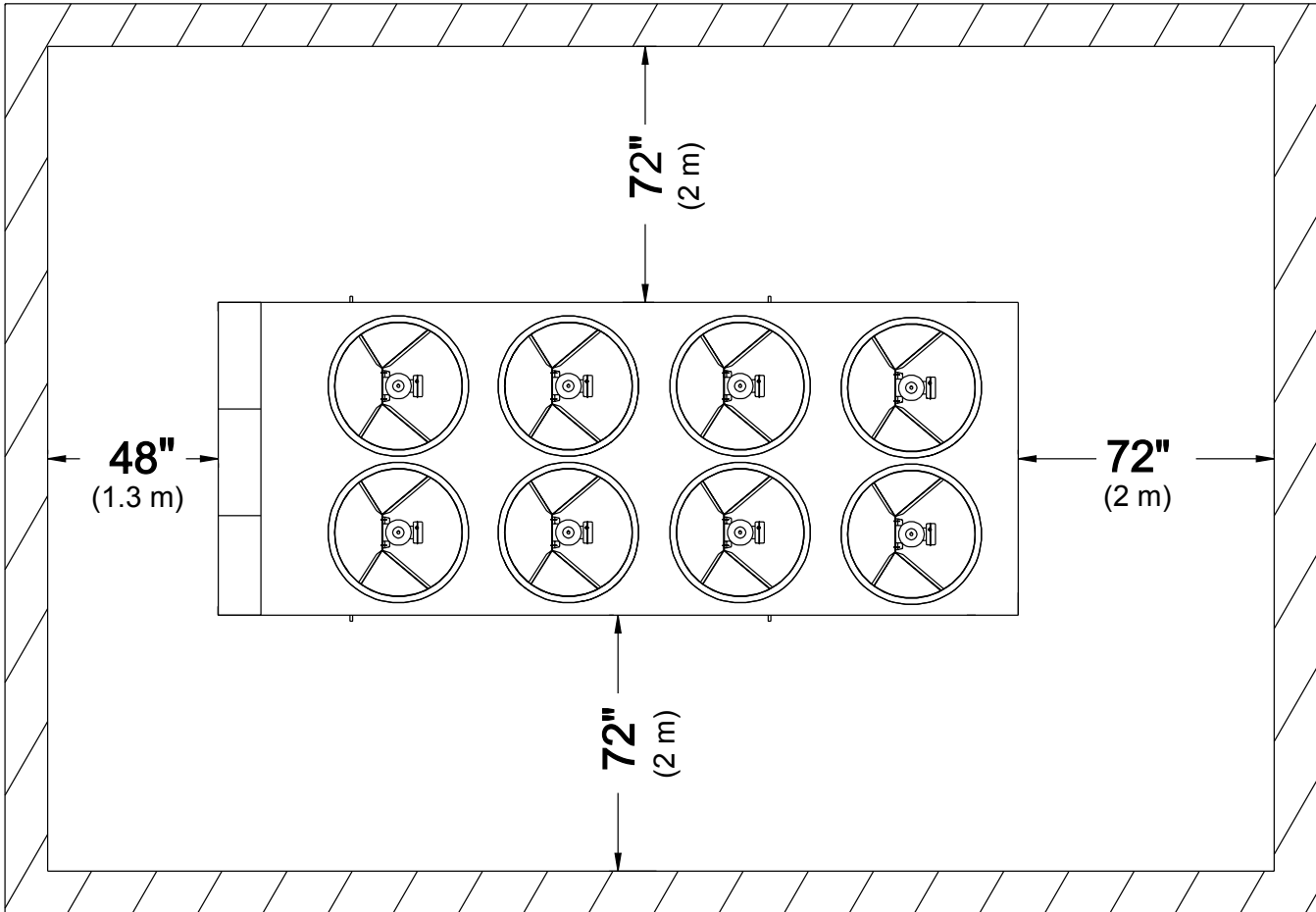

LD10506A

NOTES:

1. No obstructions allowed above the unit.
2. Only one adjacent wall may be higher than the unit
3. Adjacent units should be 10 feet (3 Meters) apart.

## ISOLATOR SELECTION AND MOUNTING STANDARD EFFICIENCY, ENGLISH

Units shipped on or after June 15, 2008

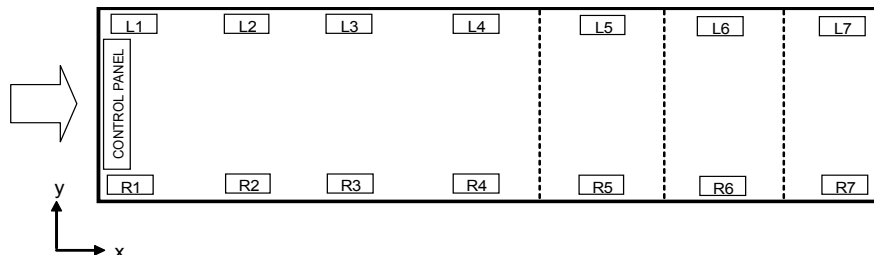

MODEL YCIV	ISOLATOR LOCATIONS (X, Y) - IN. AND POINT LOADS - LBS							
		1	2	3	4	5	6	7
0600S/P	LEFT - L	(9.1, 86.8)	(59.4, 86.8)	(109.4, 86.8)	(211, 86.8)			
	AL FIN COILS	1702	1592	1396	1340			
	CU FIN COILS	1702	1704	1739	1682			
	RS&LS1 / AL FIN COILS	1881	1770	1396	1340			
	RS&LS1 / CU FIN COILS	1881	1883	1739	1682			
	RIGHT - R	(9.1, 1.3)	(59.4, 1.3)	(109.4, 1.3)	(211, 1.3)			
	AL FIN COILS	1702	1592	1396	1340			
	CU FIN COILS	1702	1704	1739	1682			
	RS&LS1 / CU FIN COILS	1881	1883	1739	1682			
0650S/P	LEFT - L	(9.1, 86.8)	(59.4, 86.8)	(109.4, 86.8)	(211, 86.8)			
	AL FIN COILS	1720	1614	1667	1609			
	CU FIN COILS	1720	1726	2011	1951			
	RS&LS1 / AL FIN COILS	1898	1792	1667	1609			
	RS&LS1 / CU FIN COILS	1898	1905	2011	1951			
	RIGHT - R	(9.1, 1.3)	(59.4, 1.3)	(109.4, 1.3)	(211, 1.3)			
	AL FIN COILS	1702	1594	1667	1609			
	CU FIN COILS	1702	1706	2011	1951			
	RS&LS1 / CU FIN COILS	1881	1885	2011	1951			
0720S/P	LEFT - L	(9.1, 86.8)	(59.4, 86.8)	(109.4, 86.8)	(195.7, 86.8)	(265.4, 86.8)		
	AL FIN COILS	1715	1579	1559	1274	774		
	CU FIN COILS	1715	1700	1898	1653	935		
	RS&LS1 / AL FIN COILS	1894	1757	1559	1274	774		
	RS&LS1 / CU FIN COILS	1894	1878	1898	1653	935		
		(9.1, 1.3)	(59.4, 1.3)	(109.4, 1.3)	(195.7, 1.3)	(265.4, 1.3)		
	AL FIN COILS	1698	1559	1559	1241	664		
	CU FIN COILS	1698	1680	1898	1620	825		
	RS&LS1 / CU FIN COILS	1876	1858	1898	1620	825		

NOTES: 1. RS = Reduced Sound Option, LS = Low Sound Option

6

STANDARD EFFICIENCY, ENGLISH (CONT'D)

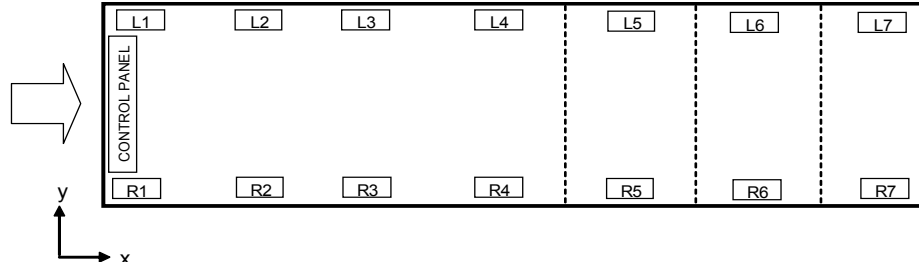

MODEL YCIV	ISOLATOR LOCATIONS (X, Y) - IN. AND POINT LOADS - LBS							
		1	2	3	4	5	6	7
0770S/P	LEFT - L	(9.1, 86.8)	(59.4, 86.8)	(109.4, 86.8)	(195.7, 86.8)	(265.4, 86.8)		
	AL FIN COILS	1728	1680	1768	1512	915		
	CU FIN COILS	1728	1801	2108	1892	1076		
	RS&LS1 / AL FIN COILS	1907	1858	1768	1512	915		
	RS&LS1 / CU FIN COILS	1907	1980	2108	1892	1076		
	RIGHT - R	(9.1, 1.3)	(59.4, 1.3)	(109.4, 1.3)	(195.7, 1.3)	(265.4, 1.3)		
	AL FIN COILS	1728	1676	1764	1475	800		
	CU FIN COILS	1728	1797	2108	1854	961		
	RS&LS1 / AL FIN COILS	1907	1854	1764	1475	800		
	RS&LS1 / CU FIN COILS	1907	1975	2103	1854	961		
0840S/P	LEFT - L	(9.1, 86.8)	(59.4, 86.8)	(109.4, 86.8)	(195.7, 86.8)	(265.4, 86.8)		
	AL FIN COILS	1728	1680	1768	1523	959		
	CU FIN COILS	1728	1801	2108	1903	1120		
	RS&LS1 / AL FIN COILS	1907	1858	1768	1523	959		
	RS&LS1 / CU FIN COILS	1907	1980	2108	1903	1120		
	RIGHT - R	(9.1, 1.3)	(59.4, 1.3)	(109.4, 1.3)	(195.7, 1.3)	(265.4, 1.3)		
	AL FIN COILS	1728	1676	1764	1519	955		
	CU FIN COILS	1728	1797	2103	1898	1116		
	RS&LS1 / AL FIN COILS	1907	1854	1764	1519	955		
	RS&LS1 / CU FIN COILS	1907	1975	2103	1898	1116		
0920S/P	LEFT - L	(9.1, 86.8)	(59.4, 86.8)	(97.2, 86.8)	(161.4, 86.8)	(210.6, 86.8)	(307.9, 86.8)	
	AL FIN COILS	1728	1638	1248	1160	1261	959	
	CU FIN COILS	1728	1728	1488	1435	1609	1199	
	RS&LS1 / AL FIN COILS	1907	1817	1248	1160	1261	959	
	RS&LS1 / CU FIN COILS	1907	1907	1488	1435	1609	1199	
	RIGHT - R	(9.1, 1.3)	(59.4, 1.3)	(97.2, 1.3)	(161.4, 1.3)	(210.6, 1.3)	(307.9, 1.3)	
	AL FIN COILS	1720	1625	1239	1153	1237	955	
	CU FIN COILS	1720	1715	1479	1429	1585	1195	
	RS&LS1 / AL FIN COILS	1898	1803	1239	1153	1237	955	
	RS&LS1 / CU FIN COILS	1898	1894	1479	1429	1590	1195	

NOTES: 1. RS = Reduced Sound Option, LS = Low Sound Option

## STANDARD EFFICIENCY, ENGLISH (CONT'D)

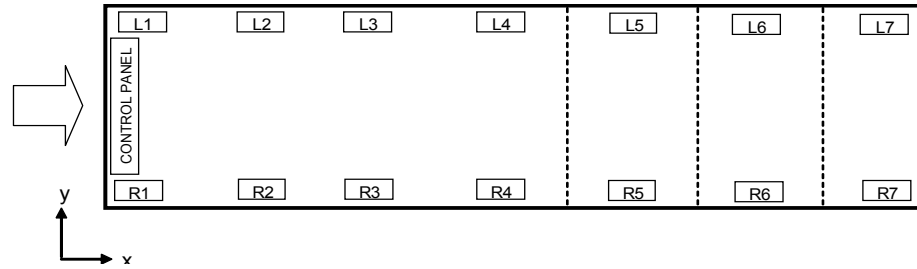

MODEL YCIV	ISOLATOR LOCATIONS (X, Y) - IN. AND POINT LOADS - LBS							
		1	2	3	4	5	6	7
1000S/P	LEFT - L	(9.1, 86.8)	(59.4, 86.8)	(97.2, 86.8)	(161.4, 86.8)	(210.6, 86.8)	(307.9, 86.8)	
	AL FIN COILS	1728	1638	1248	1160	1265	1005	
	CU FIN COILS	1728	1728	1488	1435	1614	1246	
	RS&LS1 / AL FIN COILS	1907	1817	1248	1160	1265	1005	
	RS&LS1 / CU FIN COILS	1907	1907	1488	1435	1614	1246	
	RIGHT - R	(9.1, 1.3)	(59.4, 1.3)	(97.2, 1.3)	(161.4, 1.3)	(210.6, 1.3)	(307.9, 1.3)	
	AL FIN COILS	1728	1638	1248	1160	1265	1005	
	CU FIN COILS	1728	1728	1488	1435	1614	1246	
	RS&LS1 / AL FIN COILS	1907	1817	1248	1160	1265	1005	
	RS&LS1 / CU FIN COILS	1907	1907	1488	1435	1618	1246	
1070S/P	LEFT - L	(9.1, 86.8)	(58.1, 86.8)	(111.1, 86.8)	(204.7, 86.8)	(284.9, 86.8)	(368, 86.8)	
	AL FIN COILS	1753	1585	1821	1810	2123	1175	
	CU FIN COILS	1775	1757	2165	2156	2467	1347	
	RS&LS1 / AL FIN COILS	1929	1761	1821	1810	2189	1462	
	RS&LS1 / CU FIN COILS	1885	1933	2165	2156	2533	1634	
	RIGHT - R	(9.1, 1.3)	(58.1, 1.3)	(111.1, 1.3)	(204.7, 1.3)	(284.9, 1.3)	(368, 1.3)	
	AL FIN COILS	1753	1596	2407	2414	2635	1179	
	CU FIN COILS	1775	1768	2751	2760	2978	1351	
	RS&LS1 / AL FIN COILS	1929	1773	2407	2414	2701	1466	
	RS&LS1 / CU FIN COILS	1951	1944	2751	2760	3045	1638	
1180S/P	LEFT - L	(9.1, 86.8)	(58.1, 86.8)	(111.1, 86.8)	(204.7, 86.8)	(284.9, 86.8)	(368, 86.8)	
	AL FIN COILS	1753	1585	1953	1978	2304	1184	
	CU FIN COILS	1775	1757	2297	2324	2648	1356	
	RS&LS1 / AL FIN COILS	1929	1761	1953	1978	2370	1470	
	RS&LS1 / CU FIN COILS	1951	1933	2297	2324	2714	1642	
	RIGHT - R	(9.1, 1.3)	(58.1, 1.3)	(111.1, 1.3)	(204.7, 1.3)	(284.9, 1.3)	(368, 1.3)	
	AL FIN COILS	1753	1596	2540	2632	2897	1188	
	CU FIN COILS	1775	1768	2884	2978	3241	1338	
	RS&LS1 / AL FIN COILS	1929	1773	2540	2632	2963	1475	
	RS&LS1 / CU FIN COILS	1951	1944	2884	2978	3307	1647	

NOTES: 1. RS = Reduced Sound Option, LS = Low Sound Option

6

STANDARD EFFICIENCY, ENGLISH (CONT'D)

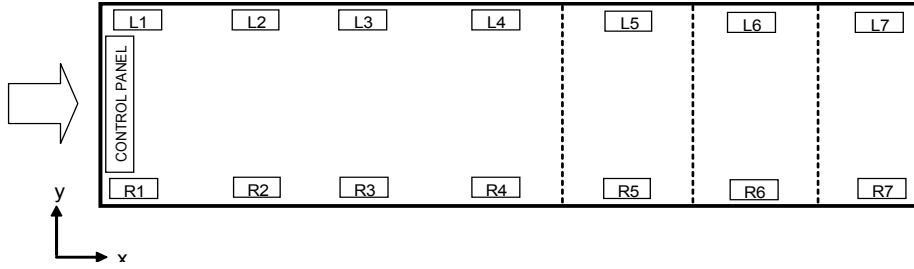

MODEL YCIV	ISOLATOR LOCATIONS (X, Y) - IN. AND POINT LOADS - LBS							
		1	2	3	4	5	6	7
1340S/P	LEFT - L	(9.1, 86.8)	(59.4, 86.8)	(109.4, 86.8)	(185.4, 86.8)	(284.4, 86.8)	(358.5, 86.8)	(411.9, 86.8)
	AL FIN COILS	1753	1585	1953	1978	1953	1140	946
	CU FIN COILS	1775	1733	2238	2363	2339	1424	1065
	RS&LS1 / AL FIN COILS	1929	1761	1953	1978	1953	1316	1122
	RS&LS1 / CU FIN COILS	1951	1909	2238	2363	2339	1601	1241
	RIGHT - R	(9.1, 1.3)	(59.4, 1.3)	(109.4, 1.3)	(185.4, 1.3)	(284.4, 1.3)	(358.5, 1.3)	(411.9, 1.3)
	AL FIN COILS	1753	1596	2540	2632	2540	1151	946
	CU FIN COILS	1775	1715	2824	3018	2926	1435	1065
	RS&LS1 / AL FIN COILS	1929	1773	2540	2632	2540	1327	1122
	RS&LS1 / CU FIN COILS	1951	1892	2824	3018	2926	1612	1241
1500S/P	LEFT - L	(9.1, 86.8)	(59.4, 86.8)	(109.4, 86.8)	(185.4, 86.8)	(298.1, 86.8)	(375.2, 86.8)	(456, 86.8)
	AL FIN COILS	1766	1607	1953	1978	2041	1404	1056
	CU FIN COILS	1788	1755	2238	2363	2427	1689	1175
	RS&LS1 / AL FIN COILS	1942	1784	1953	1978	2041	1581	1232
	RS&LS1 / CU FIN COILS	1964	1931	2238	2363	2427	1865	1351
	RIGHT - R	(9.1, 1.3)	(59.4, 1.3)	(109.4, 1.3)	(185.4, 1.3)	(298.1, 1.3)	(375.2, 1.3)	(456, 1.3)
	AL FIN COILS	1766	1618	2540	2632	2628	1415	1056
	CU FIN COILS	1788	1737	2824	3018	3014	1700	1175
	RS&LS1 / AL FIN COILS	1942	1795	2540	2632	2628	1592	1232
	RS&LS1 / CU FIN COILS	1964	1914	2824	3018	3014	1876	1351

NOTES:1. RS = Reduced Sound Option, LS = Low Sound Option

## HIGH EFFICIENCY, ENGLISH

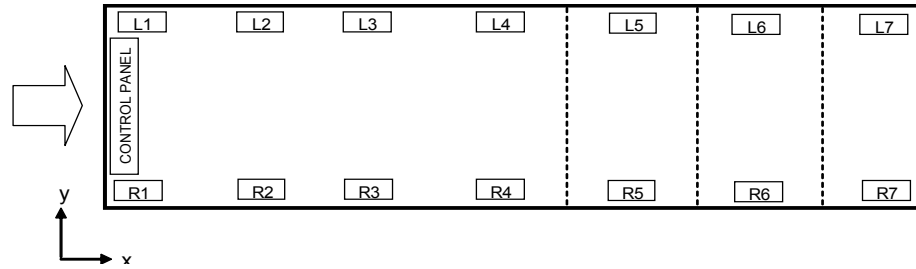

MODEL YCIV	ISOLATOR LOCATIONS (X, Y) - IN. AND POINT LOADS - LBS							
		1	2	3	4	5	6	7
0590E/V	LEFT - L	(9.1, 86.8)	(59.4, 86.8)	(109.4, 86.8)	(211, 86.8)			
	AL FIN COILS	1702	1594	1667	1609			
	CU FIN COILS	1702	1706	2011	1951			
	RS&LS1 / AL FIN COILS	1881	1773	1667	1609			
	RS&LS1 / CU FIN COILS	1881	1885	2011	1951			
	RIGHT - R	(9.1, 1.3)	(59.4, 1.3)	(109.4, 1.3)	(211, 1.3)			
	AL FIN COILS	1702	1594	1667	1609			
	CU FIN COILS	1702	1706	2011	1951			
	RS&LS1 / AL FIN COILS	1881	1773	1667	1609			
	RS&LS1 / CU FIN COILS	1881	1885	2011	1951			
0630E/V	LEFT - L	(9.1, 86.8)	(59.4, 86.8)	(109.4, 86.8)	(195.7, 86.8)	(265.4, 86.8)		
	AL FIN COILS	1698	1559	1559	1274	774		
	CU FIN COILS	1698	1680	1898	1653	935		
	RS&LS1 / AL FIN COILS	1876	1737	1559	1274	774		
	RS&LS1 / CU FIN COILS	1876	1858	1898	1653	935		
	RIGHT - R	(9.1, 1.3)	(59.4, 1.3)	(109.4, 1.3)	(195.7, 1.3)	(265.4, 1.3)		
	AL FIN COILS	1698	1559	1559	1241	664		
	CU FIN COILS	1698	1680	1898	1620	825		
	RS&LS1 / AL FIN COILS	1876	1737	1559	1241	664		
	RS&LS1 / CU FIN COILS	1876	1858	1898	1620	825		
0700E/V	LEFT - L	(9.1, 86.8)	(59.4, 86.8)	(109.4, 86.8)	(195.7, 86.8)	(265.4, 86.8)		
	AL FIN COILS	1715	1581	1676	1287	820		
	CU FIN COILS	1715	1702	2015	1667	981		
	RS&LS1 / AL FIN COILS	1894	1759	1676	1287	820		
	RS&LS1 / CU FIN COILS	1894	1881	2015	1667	981		
	RIGHT - R	(9.1, 1.3)	(59.4, 1.3)	(109.4, 1.3)	(195.7, 1.3)	(265.4, 1.3)		
	AL FIN COILS	1698	1561	1561	1287	820		
	CU FIN COILS	1698	1682	1900	1667	981		
	RS&LS1 / AL FIN COILS	1876	1739	1561	1287	820		
	RS&LS1 / CU FIN COILS	1876	1861	1900	1667	981		

NOTES: 1. RS = Reduced Sound Option, LS = Low Sound Option

6

HIGH EFFICIENCY, ENGLISH (CONT'D)

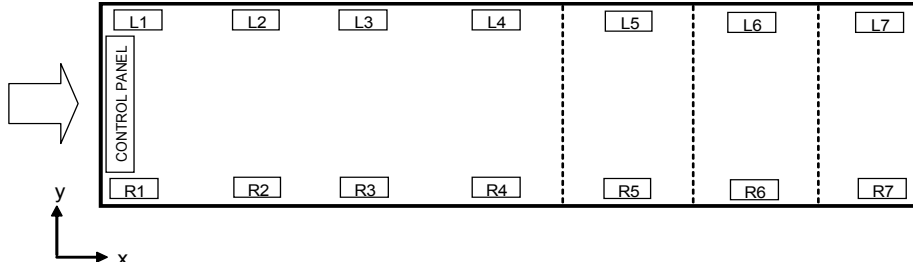

MODEL YCIV	ISOLATOR LOCATIONS (X, Y) - IN. AND POINT LOADS - LBS							
		1	2	3	4	5	6	7
0760E/V	LEFT - L	(9.1, 86.8)	(59.4, 86.8)	(109.4, 86.8)	(195.7, 86.8)	(265.4, 86.8)		
	AL FIN COILS	1720	1609	1618	1354	860		
	CU FIN COILS	1720	1731	1958	1733	1021		
	RS&LS1 / AL FIN COILS	1898	1788	1618	1354	860		
	RS&LS1 / CU FIN COILS	1898	1909	1958	1733	1021		
	RIGHT - R	(9.1, 1.3)	(59.4, 1.3)	(109.4, 1.3)	(195.7, 1.3)	(265.4, 1.3)		
	AL FIN COILS	1720	1609	1618	1354	860		
	CU FIN COILS	1720	1731	1958	1733	1021		
	RS&LS1 / AL FIN COILS	1898	1788	1618	1354	860		
RS&LS1 / CU FIN COILS	1898	1909	1958	1733	1021			
0800E/V	LEFT - L	(9.1, 86.8)	(59.4, 86.8)	(97.2, 86.8)	(161.4, 86.8)	(210.6, 86.8)	(307.9, 86.8)	
	AL FIN COILS	1720	1614	1082	994	1093	952	
	CU FIN COILS	1720	1704	1323	1270	1442	1193	
	RS&LS1 / AL FIN COILS	1898	1792	1082	994	1093	952	
	RS&LS1 / CU FIN COILS	1898	1883	1323	1270	1442	1193	
	RIGHT - R	(9.1, 1.3)	(59.4, 1.3)	(97.2, 1.3)	(161.4, 1.3)	(210.6, 1.3)	(307.9, 1.3)	
	AL FIN COILS	1720	1614	1082	994	1078	955	
	CU FIN COILS	1720	1704	1323	1270	1426	1195	
	RS&LS1 / AL FIN COILS	1898	1792	1082	994	1078	955	
RS&LS1 / CU FIN COILS	1898	1883	1323	1270	1431	1195		
0830E/V	LEFT - L	(9.1, 86.8)	(59.4, 86.8)	(97.2, 86.8)	(161.4, 86.8)	(210.6, 86.8)	(307.9, 86.8)	
	AL FIN COILS	1720	1616	1085	999	1102	1003	
	CU FIN COILS	1720	1706	1325	1274	1451	1243	
	RS&LS1 / AL FIN COILS	1898	1795	1085	999	1102	1003	
	RS&LS1 / CU FIN COILS	1898	1885	1325	1274	1451	1243	
	RIGHT - R	(9.1, 1.3)	(59.4, 1.3)	(97.2, 1.3)	(161.4, 1.3)	(210.6, 1.3)	(307.9, 1.3)	
	AL FIN COILS	1720	1616	1085	999	1102	1003	
	CU FIN COILS	1720	1706	1325	1274	1451	1243	
	RS&LS1 / AL FIN COILS	1898	1795	1085	999	1102	1003	
RS&LS1 / CU FIN COILS	1898	1885	1325	1274	1455	1243		

NOTES: 1. RS = Reduced Sound Option, LS = Low Sound Option

### HIGH EFFICIENCY, ENGLISH (CONT'D)

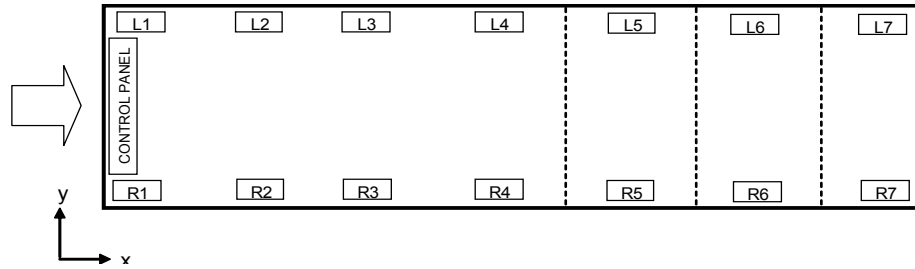

MODEL YCIV	ISOLATOR LOCATIONS (X, Y) - IN. AND POINT LOADS - LBS							
		1	2	3	4	5	6	7
0930E/V	LEFT - L	(9.1, 86.8)	(59.4, 86.8)	(97.2, 86.8)	(161.4, 86.8)	(210.6, 86.8)	(307.9, 86.8)	
	AL FIN COILS	1728	1638	1248	1160	1265	1005	
	CU FIN COILS	1728	1728	1488	1435	1614	1246	
	RS&LS1 / AL FIN COILS	1907	1817	1248	1160	1265	1005	
	RS&LS1 / CU FIN COILS	1907	1907	1488	1435	1614	1246	
	RIGHT - R	(9.1, 1.3)	(59.4, 1.3)	(97.2, 1.3)	(161.4, 1.3)	(210.6, 1.3)	(307.9, 1.3)	
	AL FIN COILS	1720	1629	1248	1160	1265	1005	
	CU FIN COILS	1720	1720	1488	1435	1614	1246	
	RS&LS1 / AL FIN COILS	1898	1808	1248	1160	1265	1005	
RS&LS1 / CU FIN COILS	1898	1898	1488	1435	1618	1246		
1050E/V	LEFT - L	(9.1, 86.8)	(58.1, 86.8)	(111.1, 86.8)	(204.7, 86.8)	(284.9, 86.8)	(368, 86.8)	
	AL FIN COILS	1753	1585	1821	1839	2163	1175	
	CU FIN COILS	1775	1757	2165	2185	2507	1347	
	RS&LS1 / AL FIN COILS	1929	1761	1821	1839	2229	1396	
	RS&LS1 / CU FIN COILS	1951	1933	2165	2185	2573	1634	
	RIGHT - R	(9.1, 1.3)	(58.1, 1.3)	(111.1, 1.3)	(204.7, 1.3)	(284.9, 1.3)	(368, 1.3)	
	AL FIN COILS	1753	1596	2407	2493	2756	1179	
	CU FIN COILS	1775	1768	2751	2840	3100	1351	
	RS&LS1 / AL FIN COILS	1929	1773	2407	2493	2822	1466	
RS&LS1 / CU FIN COILS	1951	1944	2751	2840	3166	1638		
1120E/V	LEFT - L	(9.1, 86.8)	(59.4, 86.8)	(109.4, 86.8)	(185.4, 86.8)	(284.4, 86.8)	(358.5, 86.8)	(411.9, 86.8)
	AL FIN COILS	1753	1585	1847	1870	1574	1049	928
	CU FIN COILS	1775	1733	2132	2255	1960	1334	1047
	RS&LS1 / AL FIN COILS	1929	1761	1847	1870	1574	1226	1105
	RS&LS1 / CU FIN COILS	1885	1909	2132	2255	1960	1510	1224
	RIGHT - R	(9.1, 1.3)	(59.4, 1.3)	(109.4, 1.3)	(185.4, 1.3)	(284.4, 1.3)	(358.5, 1.3)	(411.9, 1.3)
	AL FIN COILS	1753	1596	2434	2524	2344	1120	928
	CU FIN COILS	1775	1715	2718	2910	2729	1404	1047
	RS&LS1 / AL FIN COILS	1929	1773	2434	2524	2344	1296	1105
RS&LS1 / CU FIN COILS	1951	1892	2718	2910	2729	1581	1224	

NOTES: 1. RS = Reduced Sound Option, LS = Low Sound Option

6

**HIGH EFFICIENCY, ENGLISH (CONT'D)**

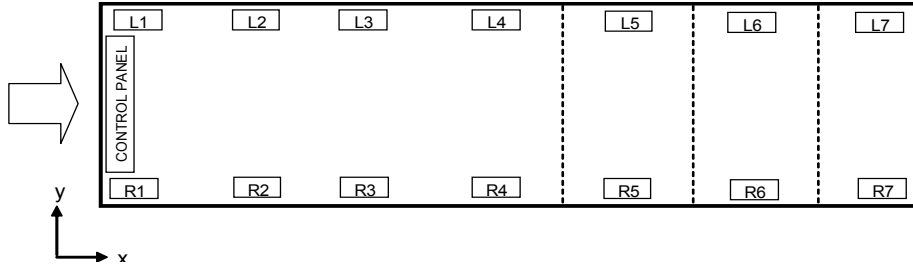

MODEL YCIV	ISOLATOR LOCATIONS (X, Y) - IN. AND POINT LOADS - LBS							
		1	2	3	4	5	6	7
1220E/V	LEFT - L	(9.1, 86.8)	(59.4, 86.8)	(109.4, 86.8)	(185.4, 86.8)	(284.4, 86.8)	(358.5, 86.8)	(411.9, 86.8)
	AL FIN COILS	1753	1585	1953	1978	1953	1140	928
	CU FIN COILS	1775	1733	2238	2363	2339	1424	1047
	RS&LS1 / AL FIN COILS	1929	1761	1953	1978	1953	1316	1105
	RS&LS1 / CU FIN COILS	1951	1931	2238	2363	2339	1601	1224
	RIGHT - R	(9.1, 1.3)	(59.4, 1.3)	(109.4, 1.3)	(185.4, 1.3)	(284.4, 1.3)	(358.5, 1.3)	(411.9, 1.3)
	AL FIN COILS	1753	1596	2540	2632	2540	1151	928
	CU FIN COILS	1775	1715	2824	3018	2926	1435	1047
	RS&LS1 / AL FIN COILS	1929	1773	2540	2632	2540	1327	1105
	RS&LS1 / CU FIN COILS	1951	1892	2824	3018	2926	1612	1224
1380E/V	LEFT - L	(9.1, 86.8)	(59.4, 86.8)	(109.4, 86.8)	(185.4, 86.8)	(298.1, 86.8)	(375.2, 86.8)	(456, 86.8)
	AL FIN COILS	1766	1607	1953	1978	2041	1404	1038
	CU FIN COILS	1788	1755	2238	2363	2427	1689	1157
	RS&LS1 / AL FIN COILS	1942	1784	1953	1978	2041	1581	1215
	RS&LS1 / CU FIN COILS	1964	1931	2238	2363	2427	1865	1334
	RIGHT - R	(9.1, 1.3)	(59.4, 1.3)	(109.4, 1.3)	(185.4, 1.3)	(298.1, 1.3)	(375.2, 1.3)	(456, 1.3)
	AL FIN COILS	1766	1618	2540	2632	2628	1415	1038
	CU FIN COILS	1788	1737	2824	3018	3014	1700	1157
	RS&LS1 / AL FIN COILS	1942	1795	2540	2632	2628	1592	1215
	RS&LS1 / CU FIN COILS	1964	1914	2824	3018	3014	1876	1334

NOTES:1. RS = Reduced Sound Option, LS = Low Sound Option

### STANDARD EFFICIENCY, SI

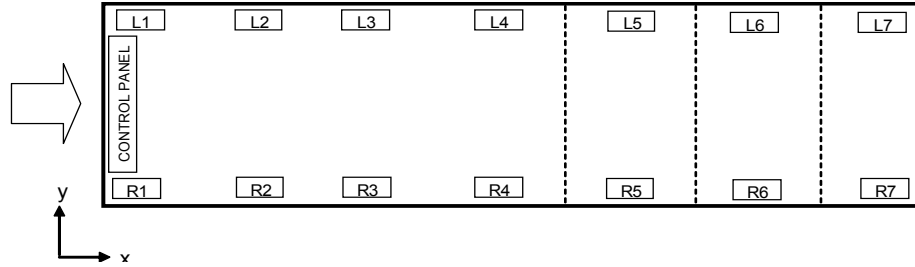

MODEL YCIV	ISOLATOR LOCATIONS (X, Y) - MM. AND POINT LOADS - KG							
		1	2	3	4	5	6	7
0600S/P	LEFT - L	(230, 2204)	(1510, 2204)	(2780, 2204)	(5360, 2204)			
	AL FIN COILS	772	722	633	608			
	CU FIN COILS	772	773	789	763			
	RS&LS1 / AL FIN COILS	853	803	633	608			
	RS&LS1 / CU FIN COILS	853	854	789	763			
	RIGHT - R	(230, 32)	(1510, 32)	(2780, 32)	(5360, 32)			
	AL FIN COILS	772	722	633	608			
	CU FIN COILS	772	773	789	763			
	RS&LS1 / AL FIN COILS	853	803	633	608			
	RS&LS1 / CU FIN COILS	853	854	789	763			
0650S/P	LEFT - L	(230, 2204)	(1510, 2204)	(2780, 2204)	(5360, 2204)			
	AL FIN COILS	780	732	756	730			
	CU FIN COILS	780	783	912	885			
	RS&LS1 / AL FIN COILS	861	813	756	730			
	RS&LS1 / CU FIN COILS	861	864	912	885			
	RIGHT - R	(230, 32)	(1510, 32)	(2780, 32)	(5360, 32)			
	AL FIN COILS	772	723	756	730			
	CU FIN COILS	772	774	912	885			
	RS&LS1 / AL FIN COILS	853	804	756	730			
	RS&LS1 / CU FIN COILS	853	855	912	885			
0720S/P	LEFT - L	(230, 2204)	(1510, 2204)	(2780, 2204)	(4970, 2204)	(6740, 2204)		
	AL FIN COILS	778	716	707	578	351		
	CU FIN COILS	778	771	861	750	424		
	RS&LS1 / AL FIN COILS	859	797	707	578	351		
	RS&LS1 / CU FIN COILS	859	852	861	750	424		
	RIGHT - R	(230, 32)	(1510, 32)	(2780, 32)	(4970, 32)	(6740, 32)		
	AL FIN COILS	770	707	707	563	301		
	CU FIN COILS	770	762	861	735	374		
	RS&LS1 / AL FIN COILS	851	788	707	563	301		
	RS&LS1 / CU FIN COILS	851	843	861	735	374		

NOTES:1. RS = Reduced Sound Option, LS = Low Sound Option

6

STANDARD EFFICIENCY, SI (CONT'D)

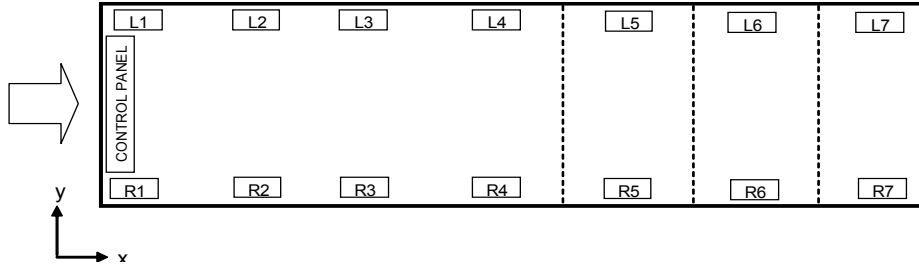

MODEL YCIV	ISOLATOR LOCATIONS (X, Y) - MM. AND POINT LOADS - KG							
		1	2	3	4	5	6	7
0770S/P	LEFT - L	(230, 2204)	(1510, 2204)	(2780, 2204)	(4970, 2204)	(6740, 2204)		
	AL FIN COILS	784	762	802	686	415		
	CU FIN COILS	784	817	956	858	488		
	RS&LS1 / AL FIN COILS	865	843	802	686	415		
	RS&LS1 / CU FIN COILS	865	898	956	858	488		
	RIGHT - R	(230, 32)	(1510, 32)	(2780, 32)	(4970, 32)	(6740, 32)		
	AL FIN COILS	784	760	800	669	363		
	CU FIN COILS	784	815	956	841	436		
	RS&LS1 / AL FIN COILS	865	841	800	669	363		
	RS&LS1 / CU FIN COILS	865	896	954	841	436		
0840S/P	LEFT - L	(230, 2204)	(1510, 2204)	(2780, 2204)	(4970, 2204)	(6740, 2204)		
	AL FIN COILS	784	762	802	691	435		
	CU FIN COILS	784	817	956	863	508		
	RS&LS1 / AL FIN COILS	865	843	802	691	435		
	RS&LS1 / CU FIN COILS	865	898	956	863	508		
	RIGHT - R	(230, 32)	(1510, 32)	(2780, 32)	(4970, 32)	(6740, 32)		
	AL FIN COILS	784	760	800	689	433		
	CU FIN COILS	784	815	954	861	506		
	RS&LS1 / AL FIN COILS	865	841	800	689	433		
	RS&LS1 / CU FIN COILS	865	896	954	861	506		
0920S/P	LEFT - L	(230, 2204)	(1510, 2204)	(24700, 2204)	(4100, 2204)	(5350, 2204)	(1820, 2204)	
	AL FIN COILS	784	743	566	526	572	435	
	CU FIN COILS	784	784	675	651	730	544	
	RS&LS1 / AL FIN COILS	865	824	566	526	572	435	
	RS&LS1 / CU FIN COILS	865	865	675	651	730	544	
	RIGHT - R	(230, 32)	(1510, 32)	(2470, 32)	(4100, 32)	(5350, 32)	(7820, 32)	
	AL FIN COILS	780	737	562	523	561	433	
	CU FIN COILS	780	778	671	648	719	542	
	RS&LS1 / AL FIN COILS	861	818	562	523	561	433	
	RS&LS1 / CU FIN COILS	861	859	671	648	721	542	

NOTES:1. RS = Reduced Sound Option, LS = Low Sound Option

### STANDARD EFFICIENCY, SI (CONT'D)

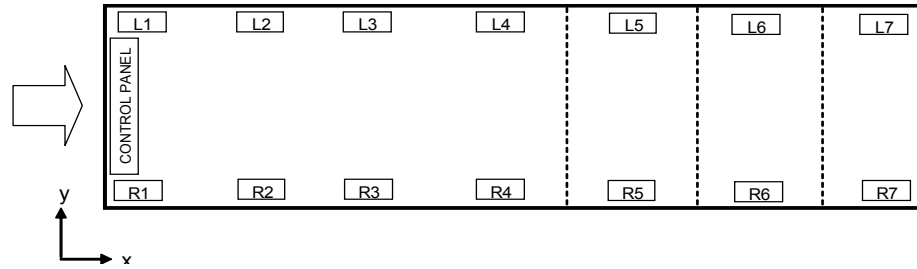

MODEL YCIV	ISOLATOR LOCATIONS (X, Y) - MM. AND POINT LOADS - KG							
		1	2	3	4	5	6	7
1000S/P	LEFT - L	(230, 2204)	(1510, 2204)	(2470, 2204)	(4100, 2204)	(5350, 2204)	(7820, 2204)	
	AL FIN COILS	784	743	566	526	574	456	
	CU FIN COILS	784	784	675	651	732	565	
	RS&LS1 / AL FIN COILS	865	824	566	526	574	456	
	RS&LS1 / CU FIN COILS	865	865	675	651	732	565	
	RIGHT - R	(230, 32)	(1510, 32)	(2470, 32)	(4100, 32)	(5350, 32)	(7820, 32)	
	AL FIN COILS	784	743	566	526	574	456	
	CU FIN COILS	784	784	675	651	732	565	
	RS&LS1 / AL FIN COILS	865	824	566	526	574	456	
	RS&LS1 / CU FIN COILS	865	865	675	651	734	565	
1070S/P	LEFT - L	(230, 2204)	(1475, 2204)	(2823, 2204)	(5199, 2204)	(7236, 2204)	(9346, 2204)	
	AL FIN COILS	795	719	826	821	963	533	
	CU FIN COILS	805	797	982	978	1119	611	
	RS&LS1 / AL FIN COILS	875	799	826	821	993	663	
	RS&LS1 / CU FIN COILS	855	877	982	978	1149	741	
	RIGHT - R	(230, 32)	(1475, 32)	(2823, 32)	(5199, 32)	(7236, 32)	(9346, 32)	
	AL FIN COILS	795	724	1092	1095	1195	535	
	CU FIN COILS	805	802	1248	1252	1351	613	
	RS&LS1 / AL FIN COILS	875	804	1092	1095	1225	665	
	RS&LS1 / CU FIN COILS	885	882	1248	1252	1381	743	
1180S/P	LEFT - L	(230, 2204)	(1475, 2204)	(2823, 2204)	(5199, 2204)	(7236, 2204)	(9346, 2204)	
	AL FIN COILS	795	719	886	897	1045	537	
	CU FIN COILS	805	797	1042	1054	1201	615	
	RS&LS1 / AL FIN COILS	875	799	886	897	1075	667	
	RS&LS1 / CU FIN COILS	885	877	1042	1054	1231	745	
	RIGHT - R	(230, 32)	(1475, 32)	(2823, 32)	(5199, 32)	(7236, 32)	(9346, 32)	
	AL FIN COILS	795	724	1152	1194	1314	539	
	CU FIN COILS	805	802	1308	1351	1470	607	
	RS&LS1 / AL FIN COILS	875	804	1152	1194	1344	669	
	RS&LS1 / CU FIN COILS	885	882	1308	1351	1500	747	

NOTES:1. RS = Reduced Sound Option, LS = Low Sound Option

6

STANDARD EFFICIENCY, SI (CONT'D)

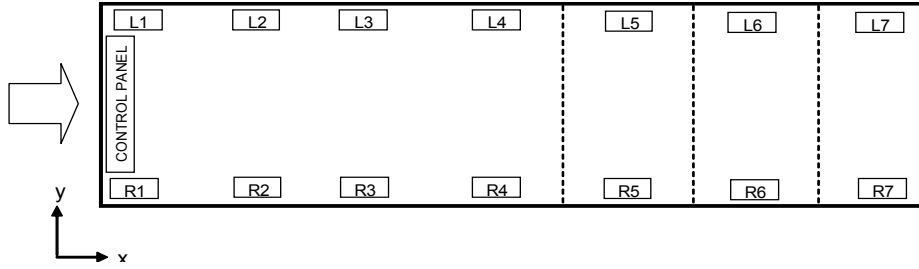

MODEL YCIV	ISOLATOR LOCATIONS (X, Y) - MM. AND POINT LOADS - KG							
		1	2	3	4	5	6	7
1340S/P	LEFT - L	(230, 2204)	(1510, 2204)	(2780, 2204)	(4710, 2204)	(7225, 2204)	(9105, 2204)	(10463, 2204)
	AL FIN COILS	795	719	886	897	886	517	429
	CU FIN COILS	805	786	1015	1072	1061	646	483
	RS&LS1 / AL FIN COILS	875	799	886	897	886	597	509
	RS&LS1 / CU FIN COILS	885	866	1015	1072	1061	726	563
	RIGHT - R	(230, 32)	(1510, 32)	(2780, 32)	(4710, 32)	(7225, 32)	(9105, 32)	(10463, 32)
	AL FIN COILS	795	724	1152	1194	1152	522	429
	CU FIN COILS	805	778	1281	1369	1327	651	483
	RS&LS1 / AL FIN COILS	875	804	1152	1194	1152	602	509
	RS&LS1 / CU FIN COILS	885	858	1281	1369	1327	731	563
1500S/P	LEFT - L	(230, 2204)	(1510, 2204)	(2780, 2204)	(4710, 2204)	(7572, 2204)	(9530, 2204)	(11582, 2204)
	AL FIN COILS	801	729	886	897	926	637	479
	CU FIN COILS	811	796	1015	1072	1101	766	533
	RS&LS1 / AL FIN COILS	881	809	886	897	926	717	559
	RS&LS1 / CU FIN COILS	891	876	1015	1072	1101	846	613
	RIGHT - R	(230, 32)	(1510, 32)	(2780, 32)	(4710, 32)	(7572, 32)	(9530, 32)	(11582, 32)
	AL FIN COILS	801	734	1152	1194	1192	642	479
	CU FIN COILS	811	788	1281	1369	1367	771	533
	RS&LS1 / AL FIN COILS	881	814	1152	1194	1192	722	559
	RS&LS1 / CU FIN COILS	891	868	1281	1369	1367	851	613

NOTES:1. RS = Reduced Sound Option, LS = Low Sound Option

## HIGH EFFICIENCY, SI

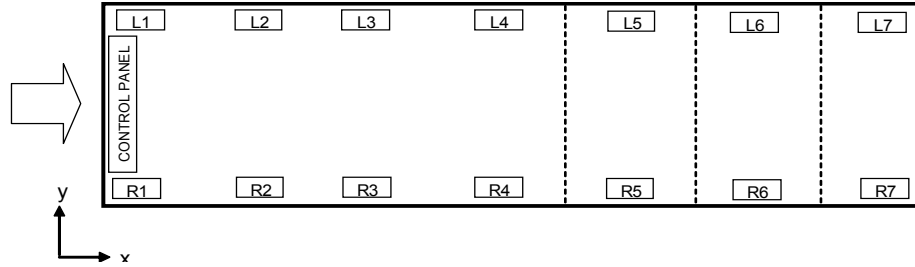

MODEL YCIV	ISOLATOR LOCATIONS (X, Y) - MM. AND POINT LOADS - KG							
		1	2	3	4	5	6	7
0590E/V	LEFT - L	(230, 2204)	(1510, 2204)	(2780, 2204)	(5360, 2204)			
	AL FIN COILS	772	723	756	730			
	CU FIN COILS	772	774	912	885			
	RS&LS1 / AL FIN COILS	853	804	756	730			
	RS&LS1/ CU FIN COILS	853	855	912	885			
	RIGHT - R	(230, 32)	(1510, 32)	(2780, 32)	(5360, 32)			
	AL FIN COILS	772	723	756	730			
	CU FIN COILS	772	774	912	885			
	RS&LS1 / AL FIN COILS	853	804	756	730			
	RS&LS1/ CU FIN COILS	853	855	912	885			
0630E/V	LEFT - L	(230, 2204)	(1510, 2204)	(2780, 2204)	(4970, 2204)	(6740, 2204)		
	AL FIN COILS	770	707	707	578	351		
	CU FIN COILS	770	762	861	750	424		
	RS&LS1 / AL FIN COILS	851	788	707	578	351		
	RS&LS1/ CU FIN COILS	851	843	861	750	424		
	RIGHT - R	(230, 32)	(1510, 32)	(2780, 32)	(4970, 32)	(6740, 32)		
	AL FIN COILS	770	707	707	563	301		
	CU FIN COILS	770	762	861	735	374		
	RS&LS1 / AL FIN COILS	851	788	707	563	301		
	RS&LS1/ CU FIN COILS	851	843	861	735	374		
0700E/V	LEFT - L	(230, 2204)	(1510, 2204)	(2780, 2204)	(4970, 2204)	(6740, 2204)		
	AL FIN COILS	778	717	760	584	372		
	CU FIN COILS	778	772	914	756	445		
	RS&LS1 / AL FIN COILS	859	798	760	584	372		
	RS&LS1/ CU FIN COILS	859	853	914	756	445		
	RIGHT - R	(230, 32)	(1510, 32)	(2780, 32)	(4970, 32)	(6740, 32)		
	AL FIN COILS	770	708	708	584	372		
	CU FIN COILS	770	763	862	756	445		
	RS&LS1 / AL FIN COILS	851	789	708	584	372		
	RS&LS1/ CU FIN COILS	851	844	862	756	445		

NOTES:1. RS = Reduced Sound Option, LS = Low Sound Option

6

HIGH EFFICIENCY, SI (CONT'D)

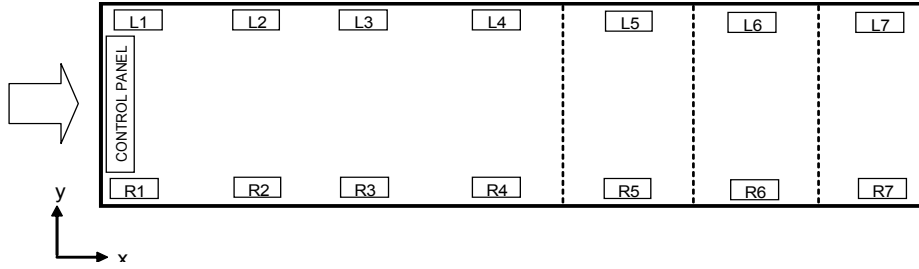

MODEL YCIV	ISOLATOR LOCATIONS (X, Y) - MM. AND POINT LOADS - KG							
		1	2	3	4	5	6	7
0760E/V	LEFT - L	(230, 2204)	(1510, 2204)	(2780, 2204)	(4970, 2204)	(6740, 2204)		
	AL FIN COILS	780	730	734	614	390		
	CU FIN COILS	780	785	888	786	463		
	RS&LS1 / AL FIN COILS	861	811	734	614	390		
	RS&LS1/ CU FIN COILS	861	866	888	786	463		
	RIGHT - R	(230, 32)	(1510, 32)	(2780, 32)	(4970, 32)	(6740, 32)		
	AL FIN COILS	780	730	734	614	390		
	CU FIN COILS	780	785	888	786	463		
	RS&LS1 / AL FIN COILS	861	811	734	614	390		
	RS&LS1/ CU FIN COILS	861	866	888	786	463		
0800E/V	LEFT - L	(230, 2204)	(1510, 2204)	(2470, 2204)	(4100, 2204)	(5350, 2204)	(7820, 2204)	
	AL FIN COILS	780	732	491	451	496	432	
	CU FIN COILS	780	773	600	576	654	541	
	RS&LS1 / AL FIN COILS	861	813	491	451	496	432	
	RS&LS1/ CU FIN COILS	861	854	600	576	654	541	
	RIGHT - R	(230, 32)	(1510, 32)	(2470, 32)	(4100, 32)	(5350, 32)	(7820, 32)	
	AL FIN COILS	780	732	491	451	489	433	
	CU FIN COILS	780	773	600	576	647	542	
	RS&LS1 / AL FIN COILS	861	813	491	451	489	433	
	RS&LS1/ CU FIN COILS	861	854	600	576	649	542	
0830E/V	LEFT - L	(230, 2204)	(1510, 2204)	(2470, 2204)	(4100, 2204)	(5350, 2204)	(7820, 2204)	
	AL FIN COILS	780	733	492	453	500	455	
	CU FIN COILS	780	774	601	578	658	564	
	RS&LS1 / AL FIN COILS	861	814	492	453	500	455	
	RS&LS1/ CU FIN COILS	861	855	601	578	658	564	
	RIGHT - R	(230, 32)	(1510, 32)	(2470, 32)	(4100, 32)	(5350, 32)	(7820, 32)	
	AL FIN COILS	780	733	492	453	500	455	
	CU FIN COILS	780	774	601	578	658	564	
	RS&LS1 / AL FIN COILS	861	814	492	453	500	455	
	RS&LS1/ CU FIN COILS	861	855	601	578	660	564	

NOTES:1. RS = Reduced Sound Option, LS = Low Sound Option

### HIGH EFFICIENCY, SI (CONT'D)

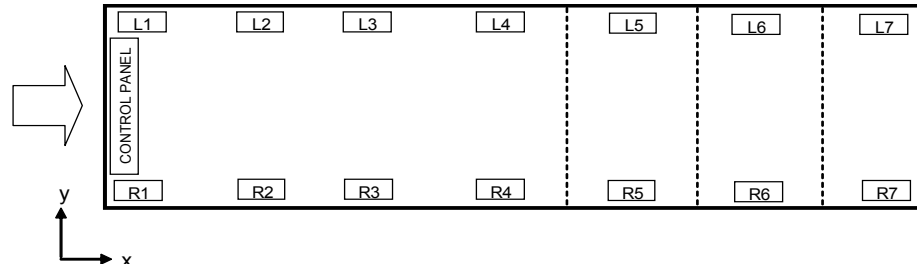

MODEL YCIV	ISOLATOR LOCATIONS (X, Y) - MM. AND POINT LOADS - KG							
		1	2	3	4	5	6	7
0930E/V	LEFT - L	(230, 2204)	(1510, 2204)	(2470, 2204)	(4100, 2204)	(5350, 2204)	(7820, 2204)	
	AL FIN COILS	784	743	566	526	574	456	
	CU FIN COILS	784	784	675	651	732	565	
	RS&LS1 / AL FIN COILS	865	824	566	526	574	456	
	RS&LS1/ CU FIN COILS	865	865	675	651	732	565	
	RIGHT - R	(230, 32)	(1510, 32)	(2470, 32)	(4100, 32)	(5350, 32)	(7820, 32)	
	AL FIN COILS	780	739	566	526	574	456	
	CU FIN COILS	780	780	675	651	732	565	
	RS&LS1 / AL FIN COILS	861	820	566	526	574	456	
RS&LS1/ CU FIN COILS	861	861	675	651	734	565		
1050E/V	LEFT - L	(230, 2204)	(1475, 2204)	(2823, 2204)	(5199, 2204)	(7236, 2204)	(9346, 2204)	
	AL FIN COILS	795	719	826	834	981	533	
	CU FIN COILS	805	797	982	991	1137	611	
	RS&LS1 / AL FIN COILS	875	799	826	834	1011	633	
	RS&LS1/ CU FIN COILS	885	877	982	991	1167	741	
	RIGHT - R	(230, 32)	(1475, 32)	(2823, 32)	(5199, 32)	(7236, 32)	(9346, 32)	
	AL FIN COILS	795	724	1092	1131	1250	535	
	CU FIN COILS	805	802	1248	1288	1406	613	
	RS&LS1 / AL FIN COILS	875	804	1092	1131	1280	665	
RS&LS1/ CU FIN COILS	885	882	1248	1288	1436	743		
1120E/V	LEFT - L	(230, 2204)	(1510, 2204)	(2780, 2204)	(4710, 2204)	(7225, 2204)	(9105, 2204)	(10463, 2204)
	AL FIN COILS	795	719	838	848	714	476	421
	CU FIN COILS	805	786	967	1023	889	605	475
	RS&LS1 / AL FIN COILS	875	799	838	848	714	556	501
	RS&LS1/ CU FIN COILS	855	866	967	1023	889	685	555
	RIGHT - R	(230, 32)	(1510, 32)	(2780, 32)	(4710, 32)	(7225, 32)	(9105, 32)	(10463, 32)
	AL FIN COILS	795	724	1104	1145	1063	508	421
	CU FIN COILS	805	778	1233	1320	1238	637	475
	RS&LS1 / AL FIN COILS	875	804	1104	1145	1063	588	501
RS&LS1/ CU FIN COILS	885	858	1233	1320	1238	717	555	

NOTES:1. RS = Reduced Sound Option, LS = Low Sound Option

6

HIGH EFFICIENCY, SI (CONT'D)

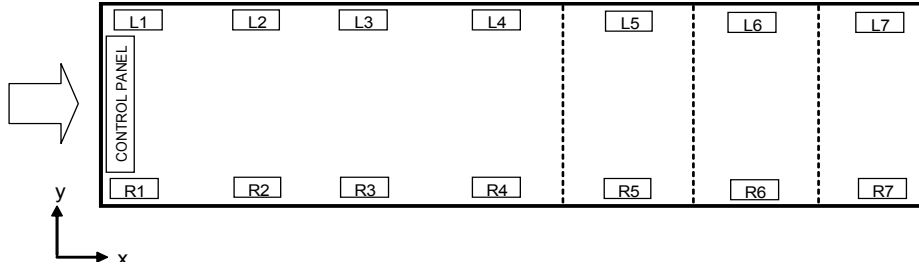

MODEL YCIV	ISOLATOR LOCATIONS (X, Y) - MM. AND POINT LOADS - KG							
		1	2	3	4	5	6	7
1220E/V	LEFT - L	(230, 2204)	(1510, 2204)	(2780, 2204)	(4710, 2204)	(7225, 2204)	(9105, 2204)	(10463, 2204)
	AL FIN COILS	795	719	886	897	886	517	421
	CU FIN COILS	805	786	1015	1072	1061	646	475
	RS&LS1 / AL FIN COILS	875	799	886	897	886	597	501
	RS&LS1/ CU FIN COILS	885	876	1015	1072	1061	726	555
	RIGHT - R	(230, 32)	(1510, 32)	(2780, 32)	(4710, 32)	(7225, 32)	(9105, 32)	(10463, 32)
	AL FIN COILS	795	724	1152	1194	1152	522	421
	CU FIN COILS	805	778	1281	1369	1327	651	475
	RS&LS1 / AL FIN COILS	875	804	1152	1194	1152	602	501
RS&LS1/ CU FIN COILS	885	858	1281	1369	1327	731	555	
1380E/V	LEFT - L	(230, 2204)	(1510, 2204)	(2780, 2204)	(4710, 2204)	(7572, 2204)	(9530, 2204)	(11582, 2204)
	AL FIN COILS	801	729	886	897	926	637	471
	CU FIN COILS	811	796	1015	1072	1101	766	525
	RS&LS1 / AL FIN COILS	881	809	886	897	926	717	551
	RS&LS1/ CU FIN COILS	891	876	1015	1072	1101	846	605
	RIGHT - R	(230, 32)	(1510, 32)	(2780, 32)	(4710, 32)	(7572, 32)	(9530, 32)	(11582, 32)
	AL FIN COILS	801	734	1152	1194	1192	642	471
	CU FIN COILS	811	788	1281	1369	1367	771	525
	RS&LS1 / AL FIN COILS	881	814	1152	1194	1192	722	551
RS&LS1/ CU FIN COILS	891	868	1281	1369	1367	851	605	

NOTES:1. RS = Reduced Sound Option, LS = Low Sound Option

## ISOLATOR CROSS REFERENCE

OLD PART NUMBER	MASON	NEW PART NUMBER	THE VMC
029-24583-002	CIP-B-450 RED	029-25334-002	CP-1D-510 BLACK
029-24583-003	CIP-B-750 WHITE	029-25334-003	CP-1D-900 DK GREEN
029-24583-004	CIP-B-1000 BLUE	029-25334-004	CP-1D-1200 GRAY
029-24583-005	CIP-B-1250 GRAY	029-25334-005	CP-1D-1360 WHITE
029-24583-006	CIP-B-1650 BLACK	029-25334-006	CP-1 D-1785N GRAY IRED
029-24583-007	CIP-C-1000 BLACK	029-25334-008	C2P-1D-1350 DARK PURPLE
029-24583-008	CIP-C-1350 YELLOW		
029-24583-009	CIP-C-1750 BLACK STRIPE WITH RED	029-25334-009	C2P-1D-1800 DARK GREEN
029-24583-010	CIP-C-2100 YELLOW WITH RED	029-25334-010	C2P-1D-2400 GRAY
029-24583-011	CIP-C-2385 YELLOW WITH GREEN		
029-24583-012	CIP-C-2650 RED WITH RED	029-25334-012	C2P-1D-2720 WHITE
029-24583-013	CIP-C-2935 RED WITH GREEN	029-25334-013	C2P-1D-3570N GRAY/IRED
029-24584-001	ND-C YELLOW	029-25335-001	RD-3 CHARCOAL-WR
029-24584-002	ND-D YELLOW	029-25335-002	RD-4 BRICK RED-WR
029-24584-004	ND-DS YELLOW	029-25335-004	RD-4 CHARCOAL-WR
029-24585-006	SLRS-2-C2-420 RED	029-25336-006	Y2RSI-2D-460 GREEN
029-24585-007	SLRS-2-C2-520 WHITE		
029-24585-008	SLRS-2-C2-660 BLACK	029-25336-008	Y2RSI-2D-710 DK BROWN
029-24585-009	SLRS-2-C2-920 BLUE	029-25336-009	Y2RSI-2D-870 RED
029-24585-010	SLRS-2-C2-1220 GREEN	029-25336-010	Y2RSI-2D-1200N RED/BLACK
029-24585-011	SLRS-2-C2-1760 GRAY	029-25336-011	Y2RSI-2D-1690 PINK
029-24585-012	SLRS-2-C2-2420 SILVER	029-25336-012	Y2RSI-2D-2640N PINK/GRAY
029-24585-013	SLRS-2-C2-3080 GRAY WITH RED	029-25336-013	Y2RSI-2D-2870N PINK/GRAY/ORANGE
029-24585-014	SLRS-2-C2-3740 SILVER WITH RED	029-25336-014	Y2RSI-2D-3600 PINK/GRAY/BROWN

# ONE INCH DEFLECTION SPRING ISOLATORS CROSS-REFERENCE

Units shipped on or after June 15, 2008

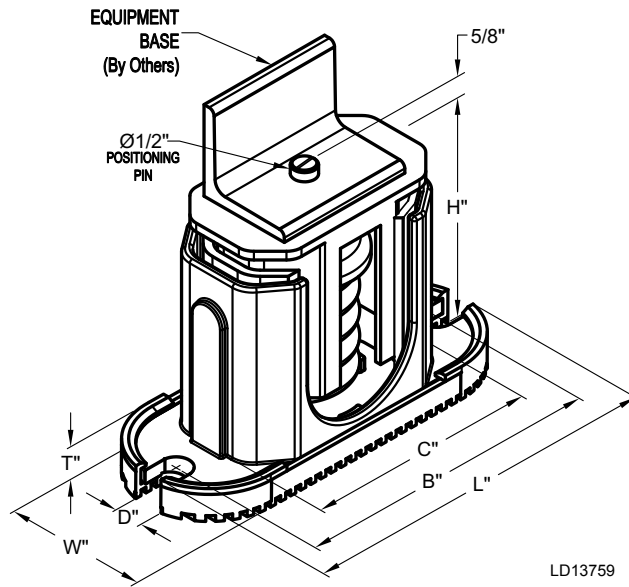

LD13759

MOUNT TYPE	DIMENSION DATA (INCHES)						
	W	D	L	B	C	T	H
CP	3	5/8	7-3/4	6-1/2	4-3/4	1/2	5-5/8
C2P	3	5/8	10-1/2	9-1/4	7-3/4	9/16	6

RATED CAPACITY (FOR UNITS WITH ALL LOAD POINTS LESS THAN 1785 LBS (810KG))		VENDOR P/N	COLOR	YORK P/N
*LBS	*KG			
Up to 434	Up to 197	CP-1D-510	BLACK	029-25334-002
435 through 765	198 through 347	CP-1D-900	DK GREEN	029-25334-003
766 through 1020	348 through 463	CP-1D-1200	GRAY	029-25334-004
1021 through 1156	464 through 524	CP-1D-1360	WHITE	029-25334-005
1157 through 1785	525 through 810	CP-1D-1785N	GRAY/RED	029-25334-006
Up through 1148	Up through 521	C2P-1D-1350	DK PURPLE	029-25334-008
1149 through 1530	522 through 694	C2P-1D-1800	DK GREEN	029-25334-009
1531 through 2040	695 through 925	C2P-1D-2400	GRAY	029-25334-010
2041 through 2312	926 through 1049	C2P-1D-2720	WHITE	029-25334-012
2313 through 3570	1050 through 1619	C2P-1D-3570N	GRAY/RED	029-25334-013

\* Value is de-rated by 15%

Note: Isolators with 1" deflection (Pin 54 = 1) must be of the same class for the entire unit. IE. Must use C2P's at all locations on a selected unit, or all CP's

Notes:

- All dimensions are in inches per ANSI Y14.
- Standard finish: Housing - Powder coated.  
Spring - Powder coated. (Color: see Table)  
Hardware - Zinc electroplate
- Installation requires bolting or anchoring mount to support structure with a min. (2) 5/8" dia. bolt or (2) 1/2" dia. concrete anchors.
- All springs are designed for 50 % over-travel.
- Refer to next page for Installation Instructions.

# ONE INCH DEFLECTION SPRING ISOLATORS INSTALLATION INSTRUCTIONS

Units shipped on or after June 15, 2008

1. Read instructions in their entirety before beginning installation.
2. Isolators are shipped fully assembled and are to be positioned in accordance with the submittal drawings or as otherwise recommended.
3. Set isolators on floor, housekeeping pad or sub-base, ensuring that all isolator centerlines match the equipment mounting holes. The VMC group recommends that the isolator base ("B") be installed on a level surface. Shim or grout as required, leveling all isolator bases to the same elevation (1/4-inch maximum difference can be tolerated).
4. Bolt or anchor all isolators to supporting structure utilizing base slotted holes ("C").
5. Place equipment on top of isolators making sure that mounting holes of the equipment line up with isolator positioning pin ("H").
6. The adjustment process can only begin after the equipment or machine is at its full operating weight.
7. Adjust each isolator in sequence by turning spring adjusting bolt ("D") one full counterclockwise turn at a time. Repeat this procedure on all isolators, one at a time.
8. Continue adjusting each isolator until a minimum of 1/4" clearance is achieved between the lower housing and upper housing. (See drawing below).
9. Fine adjust isolators to level equipment.
10. Installation is complete.

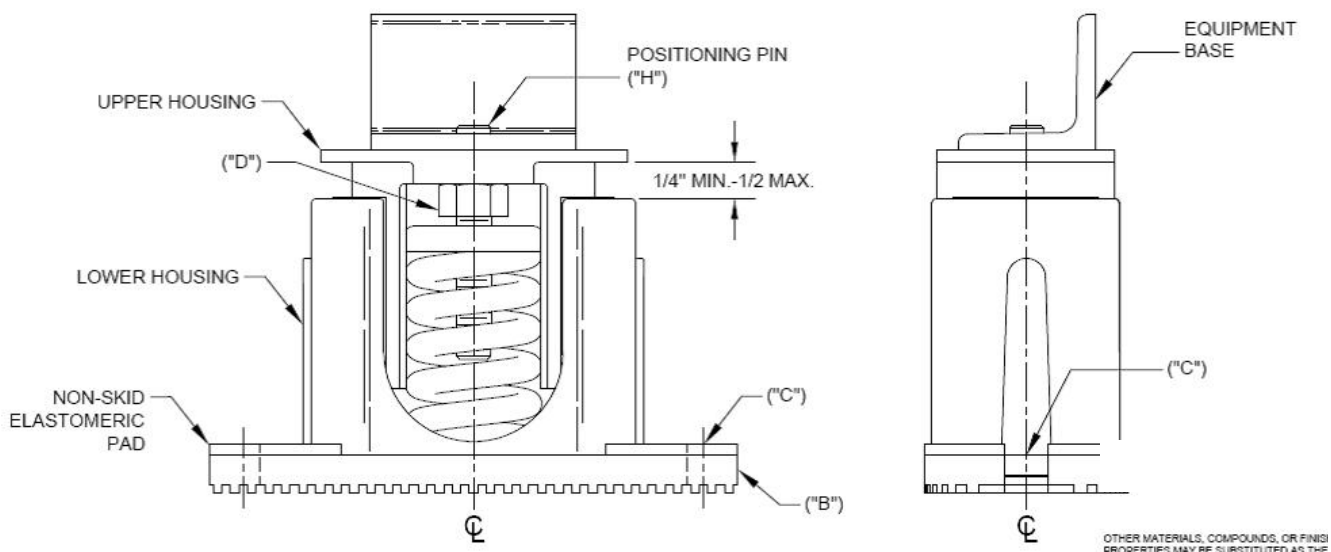

## DURULENE ISOLATOR CROSS-REFERENCE

Units shipped on or after June 15, 2008

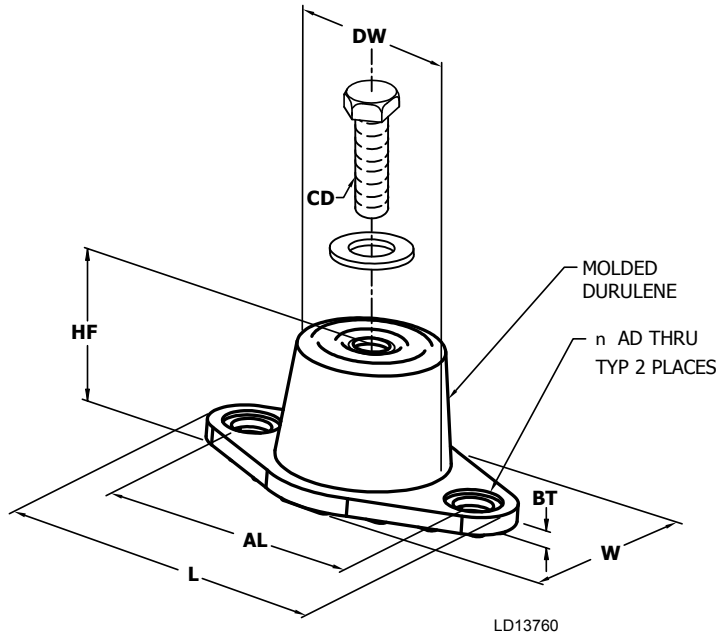

MOUNT TYPE	DIMENSION DATA (INCHES)							
	L	W	HF	AL	AD	BT	CD	DW
RD1-WR	3.13	1.75	1.25	2.38	0.34	0.19	5/16-18 UNC X 3/4	1.25
RD2-WR	3.88	2.38	1.75	3.00	0.34	0.22	3/8-16 UNC X 1	1.75
RD3-WR	5.50	3.38	2.88	4.13	0.56	0.25	1/2-13 UNC X 1	2.50
RD4-WR	6.25	4.63	2.75	5.00	0.56	0.38	1/2-13 UNC X 1	3.00

* WEIGHT RANGE (LBS)	* WEIGHT RANGE (KGS)	VENDOR P/N	COLOR	YORK P/N
Up to 825	Up to 374	RD-3 CHARCOAL-WR	CHARCOAL	029-25335-001
826 through 1688	375 through 766	RD-4 BRICK RED-WR	BRICK RED	029-25335-002
1689 through 4000	767 through 1814	RD-4 CHARCOAL-WR	CHARCOAL	029-25335-004

\* Value is de-rated by 25%

Notes:

- All dimensions are in inches per ANSI Y14.
- Refer to next page for Installation Instructions.
- Mount molded in weather resistant durulene compound as standard; also available in other materials such as natural rubber, extreme high temperature silicone, high-damped silicone, nitrile and EDPM.
- AL = Mounting hole center to center spacing.
- HF = Free height of mount, prior to loading. Operating height calculated by the free height less the static deflection under load. All dimensions for reference only.
- Hardware - Zinc electroplate.

## INSTALLATION OF DURULENE VIBRATION ISOLATORS

Units shipped on or after June 15, 2008

1. Read instructions in their entirety before beginning installation.
2. Isolators are shipped fully assembled and are to be positioned in accordance with the submittal drawings or as otherwise recommended.
3. Set isolators on floor, housekeeping pad, or sub-base, ensuring that all isolator centerlines match the equipment mounting holes. The VMC group recommends that the isolator base ("A") be installed on a level surface. Shim or grout as required, leveling all isolator bases to the same elevation (1/32-inch maximum difference can be tolerated).
4. Bolt or anchor all isolators to supporting structure utilizing base thru holes ("B").
5. Remove top bolt and top washer. Place equipment on top of isolators so that mounting holes in equipment or base line up with threaded hole ("C").
6. Reinstall top bolt and washer and tighten down.
7. Installation is complete.

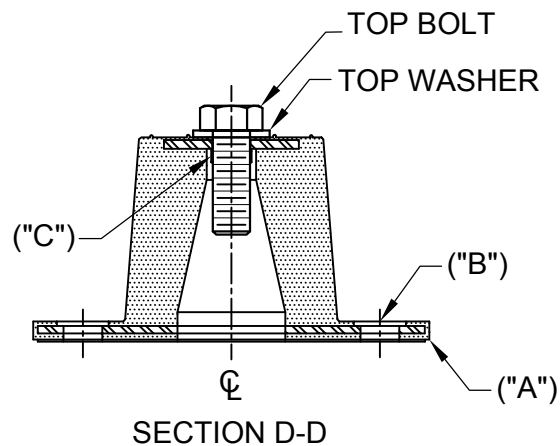
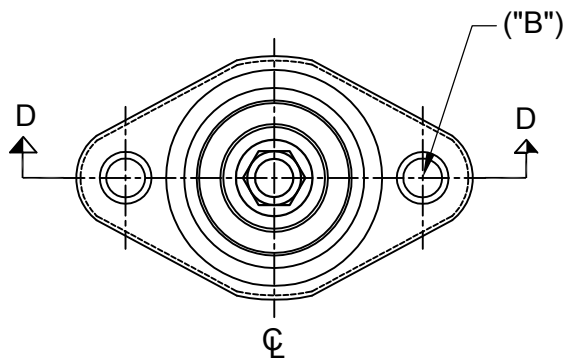

LD13762B

## SEISMIC ISOLATOR CROSS-REFERENCE

Units shipped on or after June 15, 2008

### Y2RS

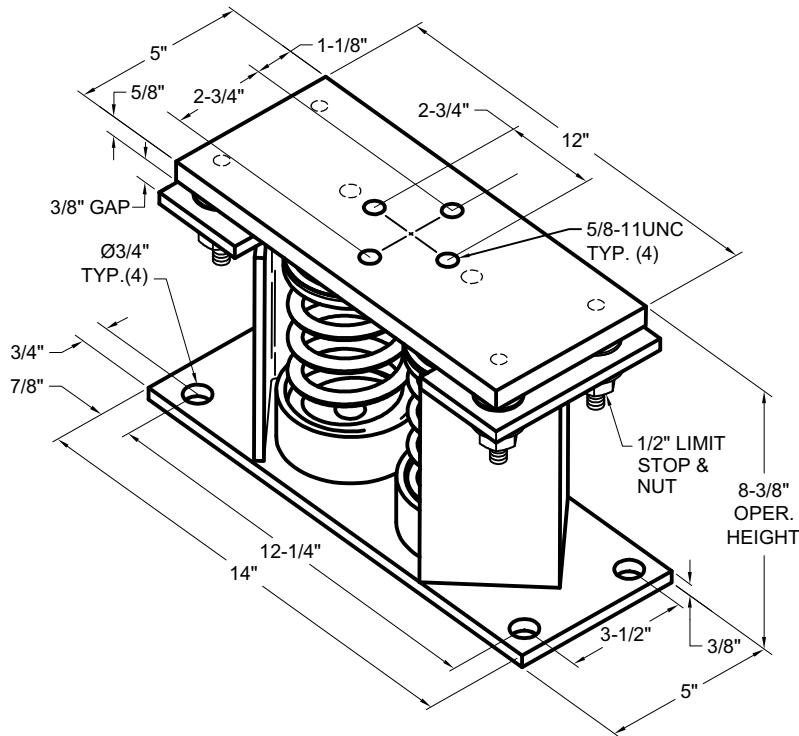

LD13761A

* WEIGHT RANGE (LBS)	* WEIGHT RANGE (KGS)	VENDOR P/N	COLOR	YORK P/N
Up to 391	Up to 177	Y2RSI-2D-460	GREEN	029-25336-006
392 through 604	178 through 274	Y2RSI-2D-710	DK BROWN	029-25336-008
605 through 740	275 through 336	Y2RSI-2D-870	RED	029-25336-009
741 through 1020	337 through 463	Y2RSI-2D-1200N	RED/BLACK	029-25336-010
1021 through 1437	464 through 652	Y2RSI-2D-1690	PINK	029-25336-011
1438 through 2244	653 through 1018	Y2RSI-2D-2640N	PINK/GRAY	029-25336-012
2245 through 2618	1019 through 1188	Y2RSI-2D-2870N	PINK/GRAY/ORANGE	029-25336-013
2619 through 3740	1189 through 1696	Y2RSI-2D-3280N	PINK/GRAY/DK BROWN	029-25336-014

\* Value is de-rated by 15%

Notes:

1. All dimensions are in inches, interpret per ANSI Y14.
2. Standard finish: housing-powder coated (color, black), spring-powder coated (color, see table above) hardware - zinc-electroplate.
3. Equipment must be bolted or welded to the top plate to meet allowable seismic ratings.
4. All springs are designed for 50% overload capacity with exception of the 2D-3280N and 2D-2870.
5. Refer to next page for installation instructions.
6. Consult factory for concrete installation.

## SEISMIC ISOLATOR INSTALLATION AND ADJUSTMENT

Units shipped on or after June 15, 2008

1. Read instructions in their entirety before beginning installation.
2. Isolators are shipped fully assembled and are to be positioned in accordance with the submittal drawings or as otherwise recommended.
3. Set isolators on floor, housekeeping pad, or sub-base, ensuring that all isolator centerlines match the equipment mounting holes. The VMC group recommends that the isolator base plates ("B") be installed on a level surface. Shim or grout as required, leveling all isolator base plates to the same elevation (1/4-inch maximum difference can be tolerated).
4. Bolt or anchor all isolators to supporting structure utilizing base plate thru holes ("C") or weld base plate to supporting structure with 3/8 fillet weld 2" long @ 4" on center around entire base plate or as engineered for specific load and or field conditions.
5. Isolators are shipped to the job site with (2) removable spacer shims ("E") between the top plate and the housing. These shims must be in place when the equipment is positioned over the isolators.
6. With all shims ("E") in place, position equipment on top of plate ("A") of isolator. Bolt equipment securely to top plate of isolator using a minimum of (2) 5/8 UNC A325 grade 5 SAE bolts or weld equipment or bracket to the top plate ("A") of isolator with a minimum of 3/8 fillet welds 2" long @ 3" on center for a minimum total weld of 10". (All sides of equipment or bracket resting on top plate ("A") must be welded).
7. The adjustment process can only begin after the equipment or machine is at its full operating weight.
8. Back off each of the (4) limit stop lock nuts ("F") on isolators 1/2".
9. Adjust each isolator in sequence by turning spring adjusting nuts ("G") one full clockwise turn at a time. Repeat this procedure on all isolators, one at a time. Check the limit stop lock nuts ("F") periodically to ensure that clearance between the washer and rubber grommet is maintained. Stop adjustment of isolator only when the top plate ("A") has risen just above the shim ("E").
10. Remove all spacer shims ("E").
11. Fine adjust isolators to level equipment.
12. Adjust all limit stop lock nuts ("F") per isolator, maintaining 1/4-to 3/8-inch gap. The limit stop lock nuts must be kept at this gap to ensure uniform bolt loading during uplift (as the case when equipment is drained).
13. Installation is complete.

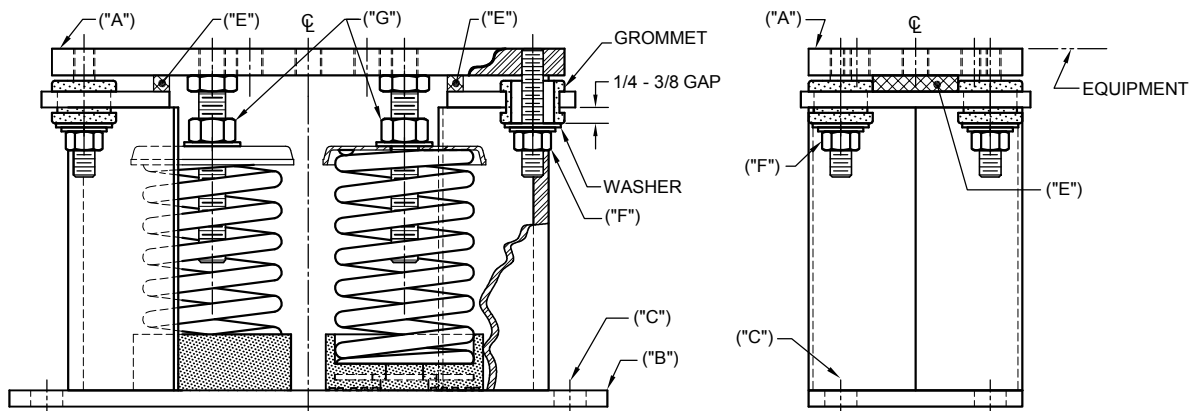

LD13763B

## SLRS SEISMIC ISOLATOR SPECIFICATIONS

Units shipped before June 15, 2008

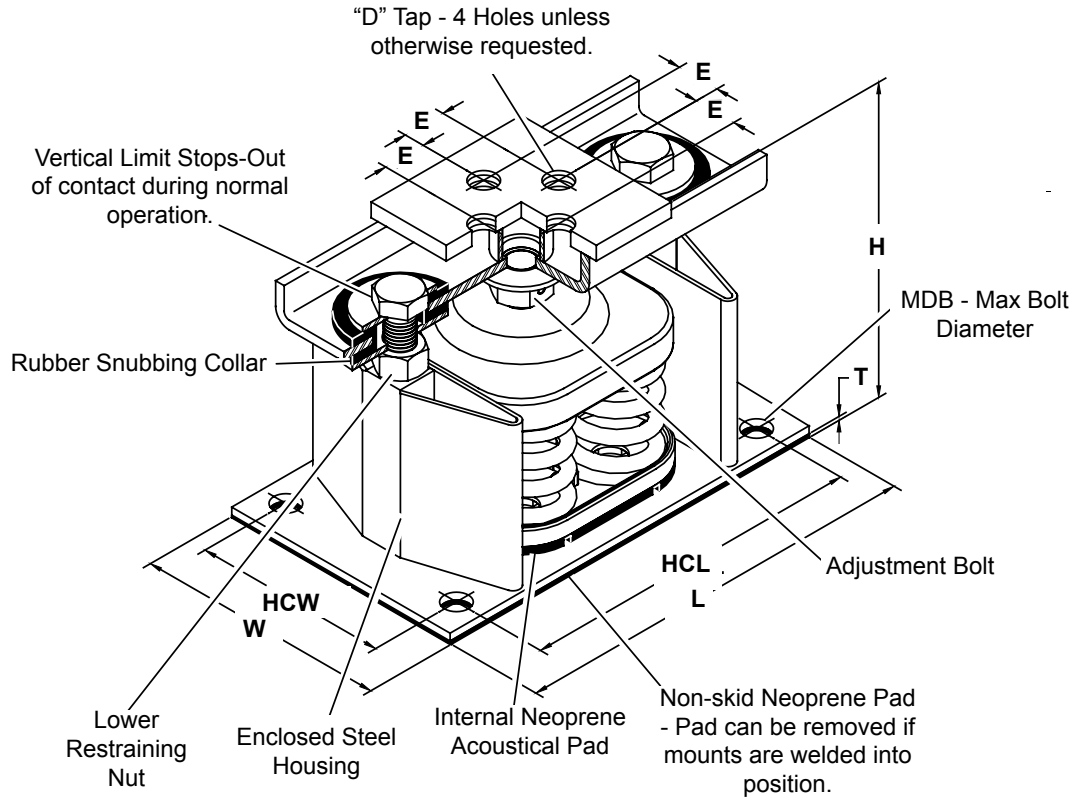

LD10509

PIN 54 = S				
*Weight Range (lbs)	*Weight Range (kg)	Vendor P/N	COLOR	YORK P/N
UP TO 358 LBS	Up to 162 kg	SLRS-2-C2-420	Red	029-24585-006
358-442 LBS	162 to 201 kg	SLRS-2-C2-520	White	029-24585-007
443-581 LBS	201 to 264 kg	SLRS-2-C2-660	Black	029-24585-008
582-782 LBS	264 to 335 kg	SLRS-2-C2-920	Blue	029-24585-009
783-1037 LBS	335 to 471 kg	SLRS-2-C2-1220	Green	029-24585-010
1038-1496 LBS	471 to 679 kg	SLRS-2-C2-1760	Gray	029-24585-011
1497-2057 LBS	679 to 933 kg	SLRS-2-C2-2420	Silver	029-24585-012
2058-2618 LBS	933 to 1188 kg	SLRS-2-C2-3080	Gray w/ Red	029-24585-013
2619-3179 LBS	1188 to 1442 kg	SLRS-2-C2-3740	Silver w/ Red	029-24585-014

\* Value is de-rated by 15%

**Notes:** Illustration above shows a SLRS-4-C2 (4 Springs). SLRS-8-2 and C2 have one spring, and SLRS-2-C2 has two springs. SLRS-6-C2 has six springs and SLRS-9-C2 has nine springs.

# SLRS SEISMIC ISOLATOR INSTALLATION AND ADJUSTMENT

Units shipped before June 15, 2008

## To Install and Adjust Mounts

1. Supports for mountings must be leveled to installation's acceptable tolerances.
2. Mountings not subjected to seismic or wind forces do not require bolting to supports.
3. Mountings subjected to seismic or wind forces must be bolted or welded in position.
4. If mountings are welded in position, remove lower friction pad before welding.
5. Set mountings with top channels held in place by the lower restraining nuts and limit stops.
6. Place equipment on mountings and secure by bolting or welding.
7. Hold lower restraining nut in place and turn vertical limit stop bolt counter-clockwise until there is a 1/8" gap between the bolt head and the steel washer.
8. Turn adjustment bolt 8 turns on each mount.
9. Take one additional complete turn on each adjustment bolt in sequence until the top plate lifts off of the lower restraining nuts. Take no additional turns on that mount. Continue with equal turns on the other mounts until the top plates lift off of the lower restraining nuts of all mounts.
10. Hold the limit stop bolt in place and turn the lower restraining nut clockwise and tighten it against the stanchion. Repeat the same procedure on all mounts.
11. Top plate should remain at a fixed elevation, plus or minus 1/8".

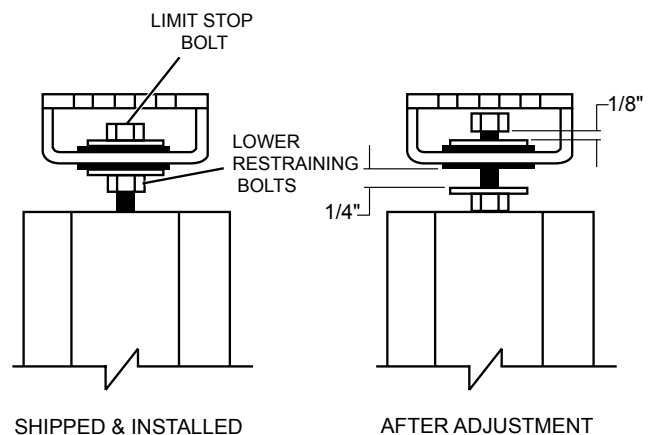
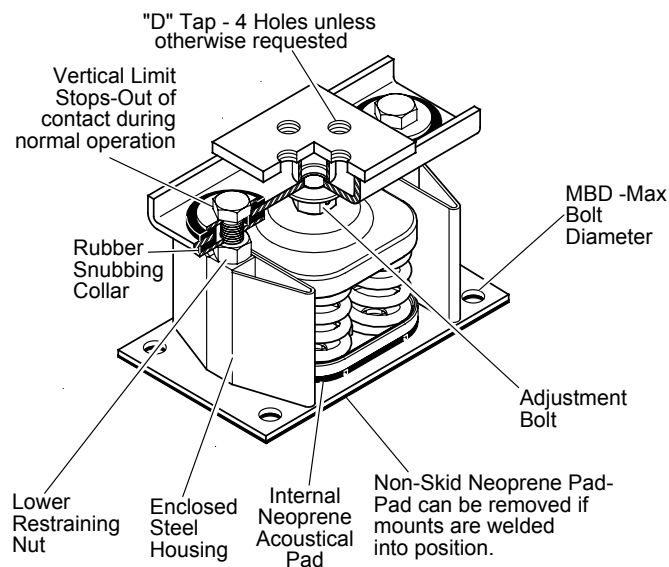

LD10568

## ND-X NEOPRENE ISOLATOR SPECIFICATIONS

Units shipped before June 15, 2008

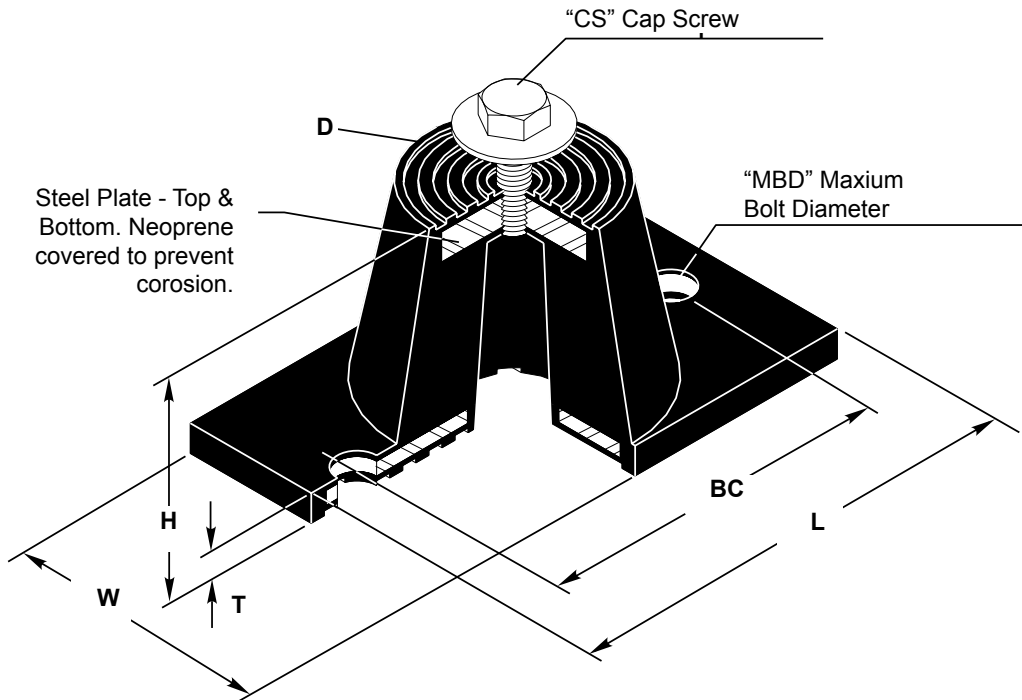

LD10569

ENGLISH								
SIZE	D	H	L	T	W	BC	CS	MBD
ND-C	2-9/16	2-3/4	5-1/2	1/4	2-5/16	4-1/8	1/2-13X1"	1/2"
ND-D	3-3/8	2-3/4	6-1/4	5/16	4	5	1/2-13X1"	1/2"
ND-DS	3-3/8	2-3/4	6-1/4	5/16	4	5	1/2-13X1"	1/2"
SI								
ND-C	65.1	69.9	139.7	6.4	58.7	101.9	1/2-13X1"	13
ND-D	85.7	69.9	158.8	7.9	101.6	127.0	1/2-13X1"	13
ND-DS	85.7	69.9	158.8	7.9	101.6	127.0	1/2-13X1"	13

PIN 54 = N				
**Weight Range (lbs)	**Weight Range (kg)	COLOR	YORK P/N	YORK P/N
UP TO 751 LBS	Up to 341 kg	ND-C	Yellow	029-24584-001
751-1651 LBS	341 to 749 kg	ND-D	Yellow	029-24584-002
1651-3226 LBS	749 to 1463 kg	ND-E	Yellow	029-24584-003

\*\* Value is de-rated by 15%

### Installation of Neoprene Mounts

It is not necessary to bolt the mountings to a concrete pad in most cases. Mountings should always be bolted to the chiller rails. When mountings and the chiller are installed on steel framing above the ground, the mountings should be bolted to the steel framework. Lower

the chiller on to the mountings evenly to avoid placing excessive weight on individual isolators.

## CIP 1" DEFLECTION RESTRAINED MOUNTING SPECIFICATIONS

Units shipped before June 15, 2008

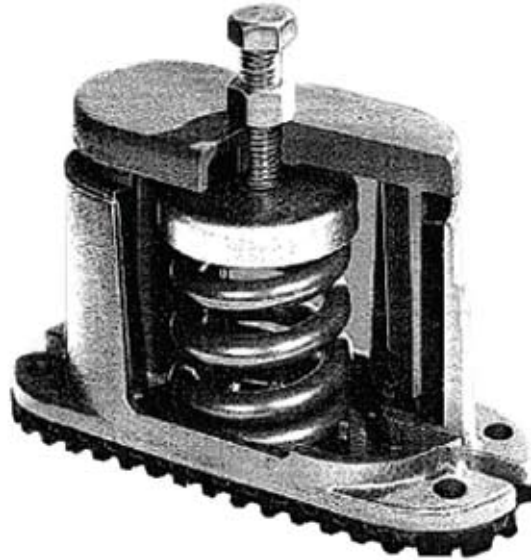

LD10576

6

<b>PIN 54 = 1 (See note below)</b>				
<b>For Units With All Load Points Less than 1404 LBS (637 KG)</b>				
<b>*Weight Range (lbs)</b>	<b>*Weight Range (kg)</b>	<b>Vendor P/N</b>	<b>Color</b>	<b>YORK P/N</b>
239-384 LBS	108 to 174 kg	CIP-B-450	Red	029-24583-002
384-639 LBS	174 to 290 kg	CIP-B-750	White	029-24583-003
639-851 LBS	290 to 386 kg	CIP-B-1000	Blue	029-24583-004
851-1064 LBS	386 to 483 kg	CIP-B-1250	Gray	029-24583-005
1064-1404 LBS	483 to 637 kg	CIP-B-1650	Black	029-24583-006
<b>For Units With Any Load Point Above 1404 LBS (637 KG)</b>				
UP TO 851 LBS	Up to 386 kg	CIP-C-1000	Black	029-24583-007
851-1149 LBS	386 to 521 kg	CIP-C-1350	Yellow	029-24583-008
1149-1489 LBS	521 to 675 kg	CIP-C-1750	Black w/ Red	029-24583-009
1489-1786 LBS	675 to 810 kg	CIP-C-2100	Yellow w/ Red	029-24583-010
1786-2028 LBS	810 to 920 kg	CIP-C-2385	Yellow w/ Green	029-24583-011
2028-2254 LBS	920 to 1022 kg	CIP-C-2650	Red w/ Red	029-24583-012
2354-2936 lbs	1022 to 1332 kg	CIP-C-2935	Red w/ Green	029-24583-013

\* Value is de-rated by 15%

# INSTALLATION OF 1" DEFLECTION MOUNTS

Units shipped before June 15, 2008

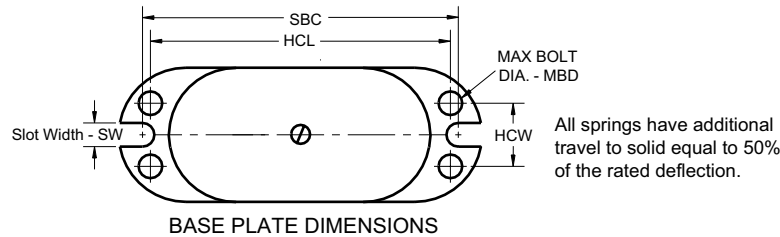
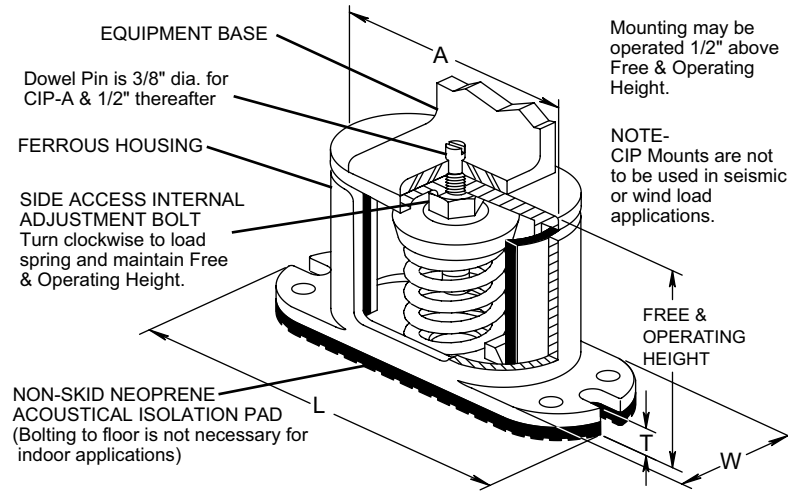

TYPE CIP DIMENSIONS (inches)†

Size	A	L	T	W	SW	HCL	HCW	MBD	SBC	Free Ht.	Min Ht.
CIP-B	5 <sup>3</sup> / <sub>4</sub>	8 <sup>1</sup> / <sub>4</sub>	1/2	2 <sup>3</sup> / <sub>4</sub>	7/16	6 <sup>1</sup> / <sub>2</sub>	1 <sup>1</sup> / <sub>2</sub>	3/8	7 <sup>1</sup> / <sub>4</sub>	6 <sup>1</sup> / <sub>8</sub>	5 <sup>1</sup> / <sub>4</sub>
CIP-C	6 <sup>5</sup> / <sub>8</sub>	8 <sup>7</sup> / <sub>8</sub>	9/16	3 <sup>1</sup> / <sub>2</sub>	7/16	7 <sup>1</sup> / <sub>4</sub>	1 <sup>3</sup> / <sub>4</sub>	3/8	7 <sup>7</sup> / <sub>8</sub>	6 <sup>3</sup> / <sub>4</sub>	6 <sup>3</sup> / <sub>4</sub>

†Casting dimensions may vary ±1/8"

LD10577

- Floor or steel frame should be level and smooth.
- For pad installations, isolators do not normally require bolting. If necessary, anchor isolators to floor through bolt holes in the base plate.
- Lubricate the threads of adjusting bolt. Loosen the hold down bolts to allow for isolator adjustment.
- Block the equipment 10mm (1/4") higher than the specified free height of the isolator. To use the isolator as blocking for the equipment, insert a 10mm (1/4") shim between the upper load plate and vertical uprights. Lower the equipment on the blocking or shimmed isolators.
- Complete piping and fill equipment with water, refrigerant, etc.
- Turn leveling bolt of first isolator four full revolutions and proceed to each mount in turn.
- Continue turning leveling bolts until the equipment is fully supported by all mountings and the equipment is raised free of the spacer blocks or shims. Remove the blocks or shims.
- Turn the leveling bolt of all mountings in either direction in order to level the installation.
- Tighten the resilient washer and underside of channel cap plate.
- Installation is now complete.

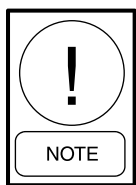

**Isolators must be bolted to the sub-structure and the equipment must be bolted to the isolators when outdoor equipment is exposed to wind forces.**

# REFRIGERANT FLOW DIAGRAM

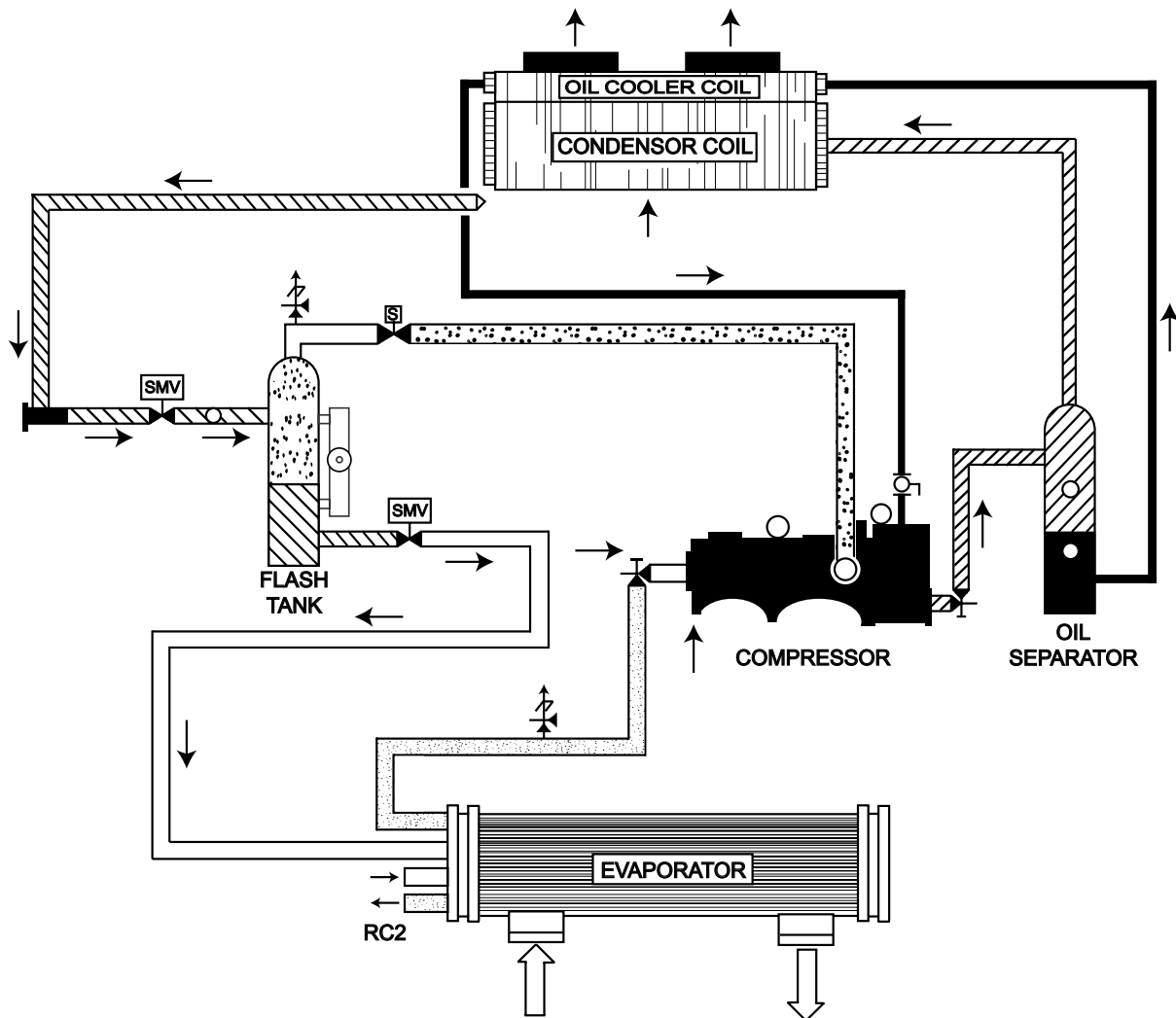

6

Low Pressure Liquid	Low Pressure Vapor	High Pressure Vapor
Medium Pressure Vapor	High Pressure Liquid	Oil
Stopper Motor Valve	Angle Stop Valve	M <sup>3</sup> S - Air Entering Compressor
Solenoid Valve	Sight Glass	R134a - Refrigerant Circuit Number
Relief Valve	Filter or Dryer	Economizer (Added to some models)
Ball Valve		

LD10505

FIG. 21 - REFRIGERANT FLOW DIAGRAM

PROCESS AND INSTRUMENTATION DIAGRAM

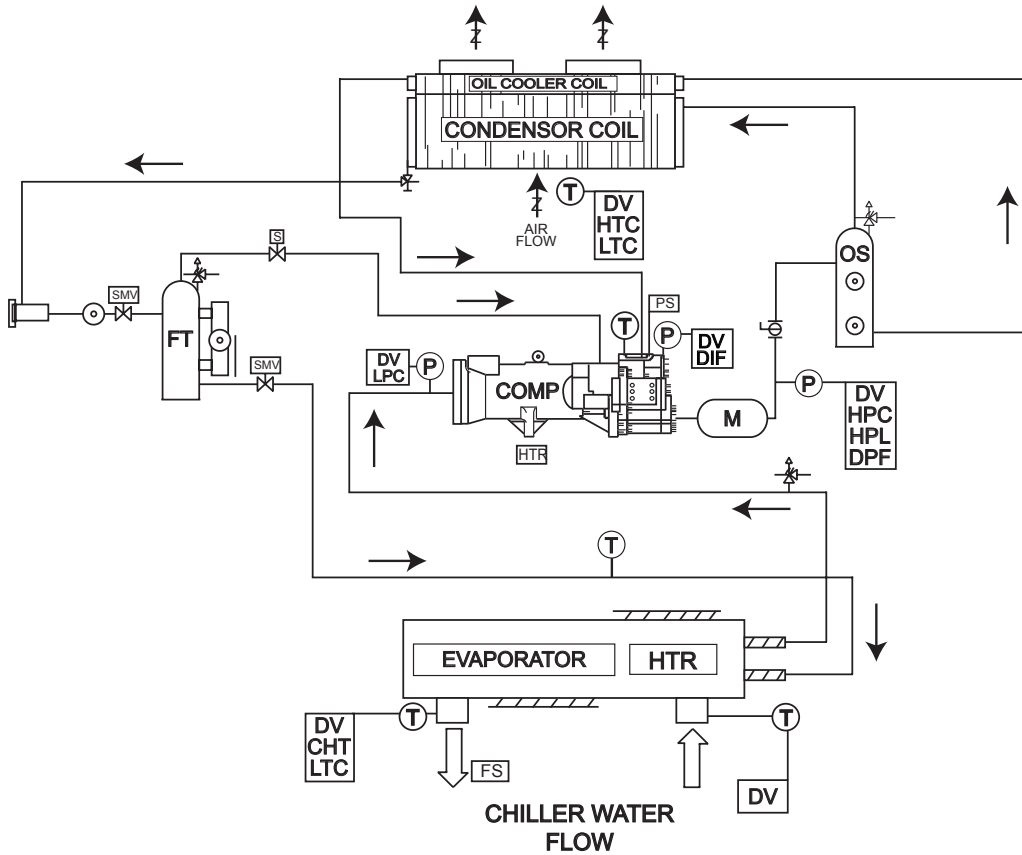

SYSTEM COMPONENTS

- STEPPER MOTOR VALVE
- SOLENOID VALVE
- BALL VALVE
- RELIEF VALVE
- STOP VALVE ANGLE, ACCESS
- PRESSURE SENSOR
- TEMPERATURE SENSOR
- REPLACEABLE CORE FILTER/DRYER
- SIGHT GLASS
- FLOW SWITCH (optional)
- PRESSURE SWITCH
- ELECTRIC HEATER
- PLUG

MAJOR COMPONENTS

- COMP COMPRESSOR
- OS OIL SEPARATOR
- FT FLASH TANK
- M MUFFLER

MICROPROCESSOR CONTROL FUNCTIONS

- CHT CHILLED LIQUID THERMOSTAT
- DP DIFFERENTIAL PRESSURE CUTOUT
- DPF DISCHARGE PRESSURE FAN CONTROL
- DV DISPLAY VALUE
- HPL HIGH PRESSURE LOAD LIMITING
- HTC HIGH TEMPERATURE CUTOUT
- LPC LOW PRESSURE CUTOUT
- LTC LOW TEMPERATURE CUTOUT
- HPC HIGH PRESSURE CUTOUT
- HTR HEATER
- DIF DIFFERENTIAL

LD10589A

FIG. 22 - PROCESS AND INSTRUMENTATION DIAGRAM

# COMPONENT LOCATIONS

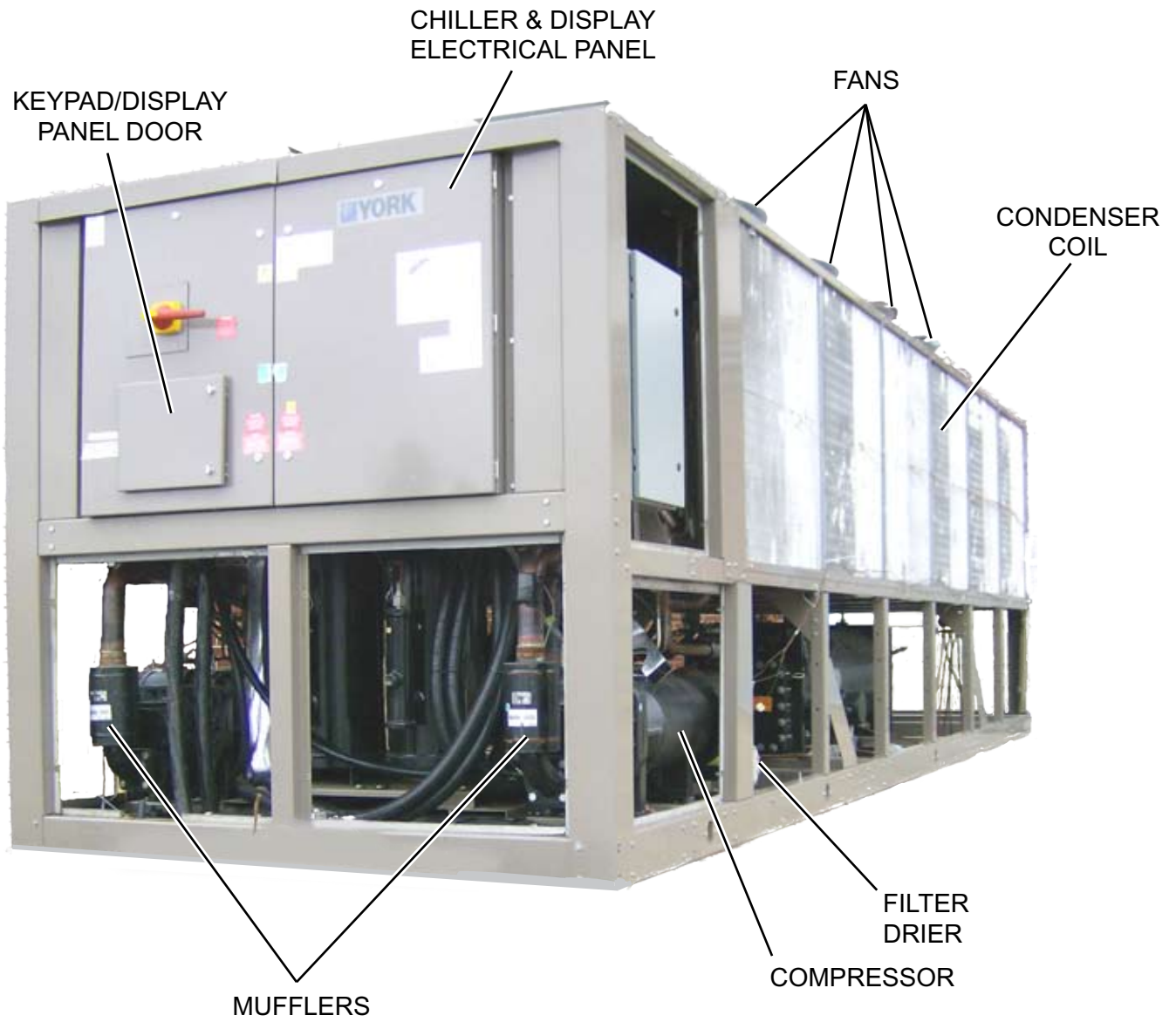

6

LD13121

FIG. 23 - COMPONENT LOCATIONS

### COMPONENT LOCATIONS (CONT'D)

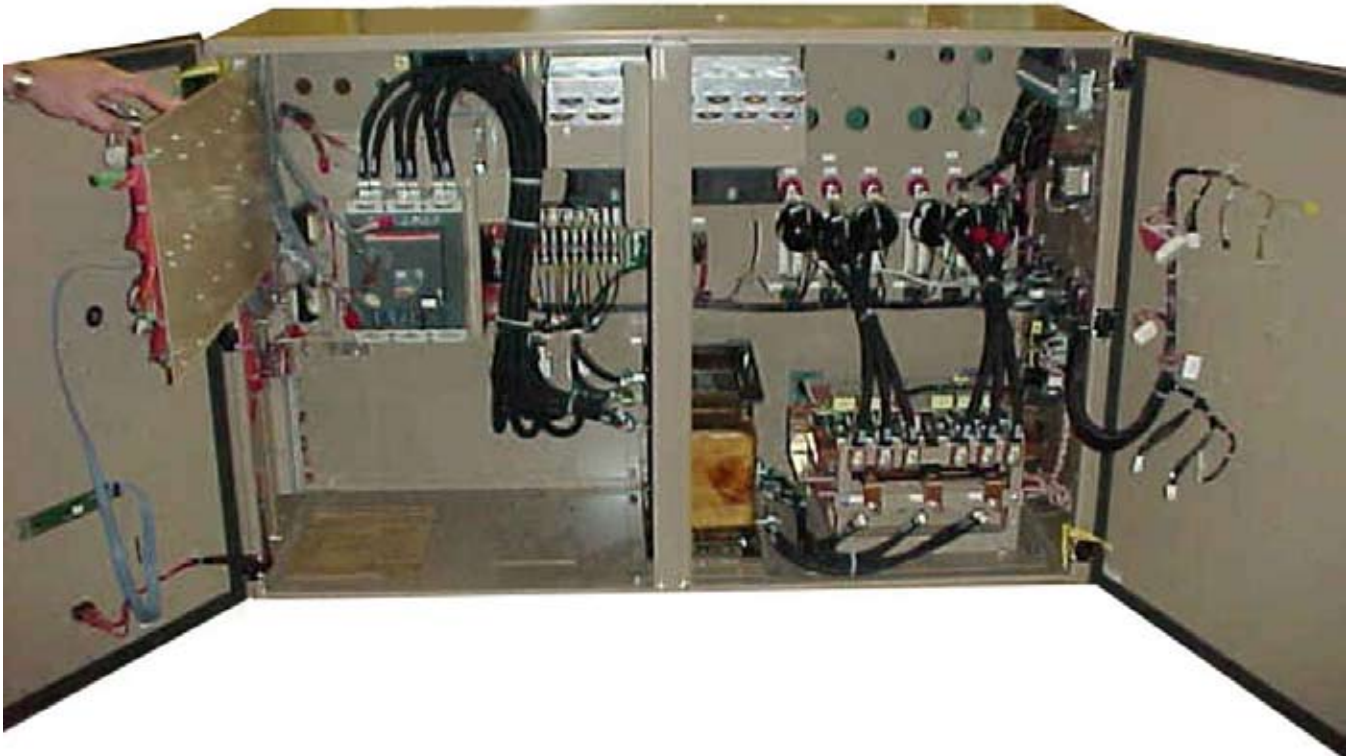

LD10578

FIG. 24 - CONTROL AND VSD CABINET COMPONENTS

## COMPONENT LOCATIONS (CONT'D)

6

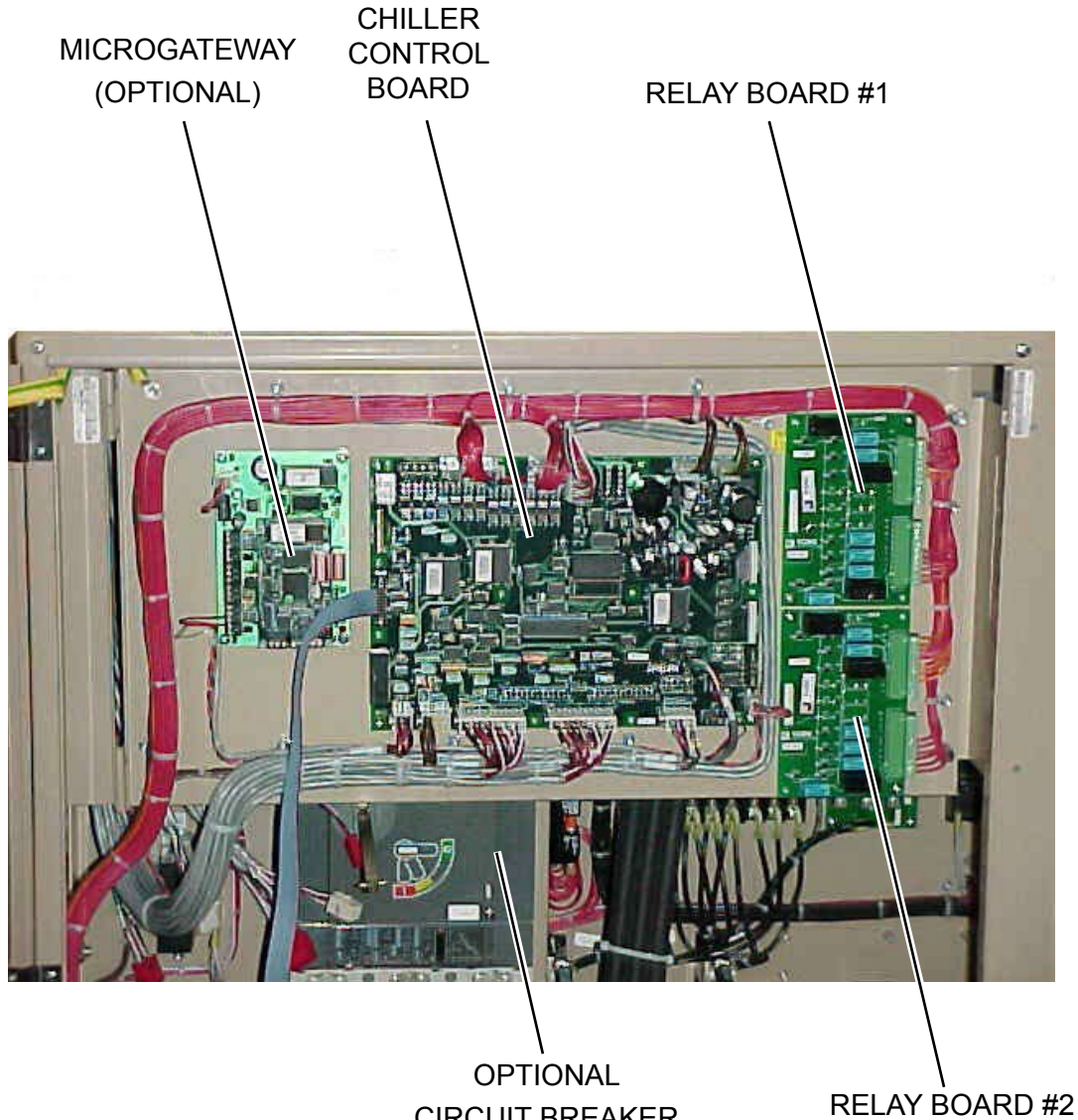

LD10579

(Standard Unit will have terminal blocks. Input power to the chiller will be connected here (see Figures.-31 and 32)).

**FIG. 25 - CHILLER CONTROL BOARD, RELAY BOARDS, MICROGATEWAY, AND OPTIONAL CIRCUIT BREAKER**

### COMPONENT LOCATIONS (CONT'D)

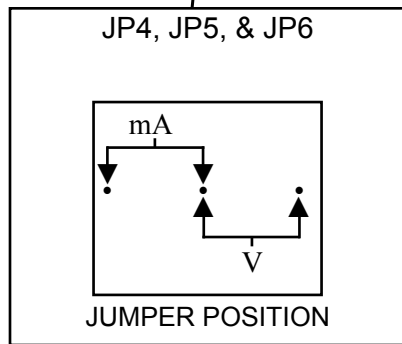
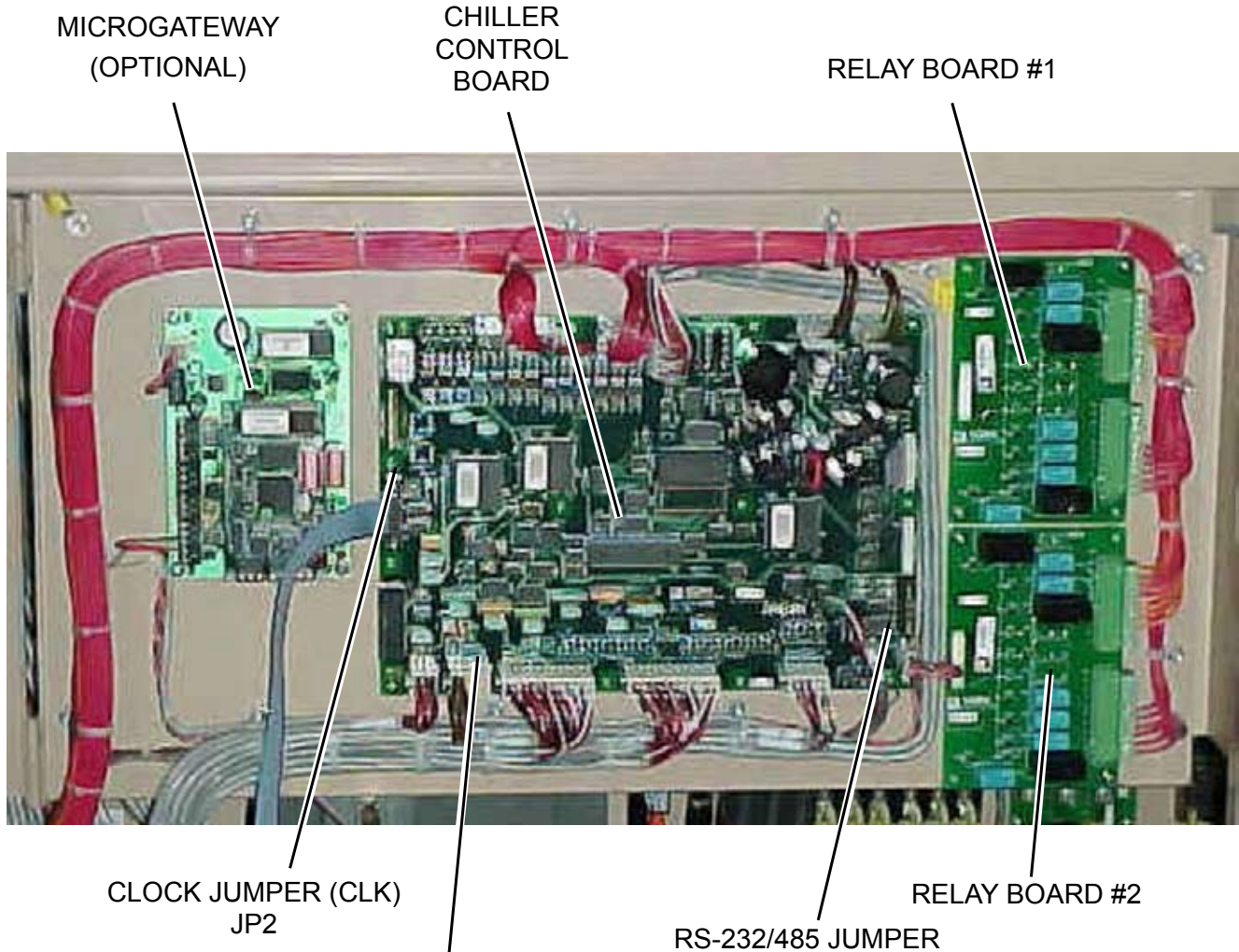

LD10580

FIG. 26 - CHILLER CONTROL BOARD, RELAY BOARDS, AND MICROGATEWAY, 2 COMPRESSOR

### COMPONENT LOCATIONS (CONT'D)

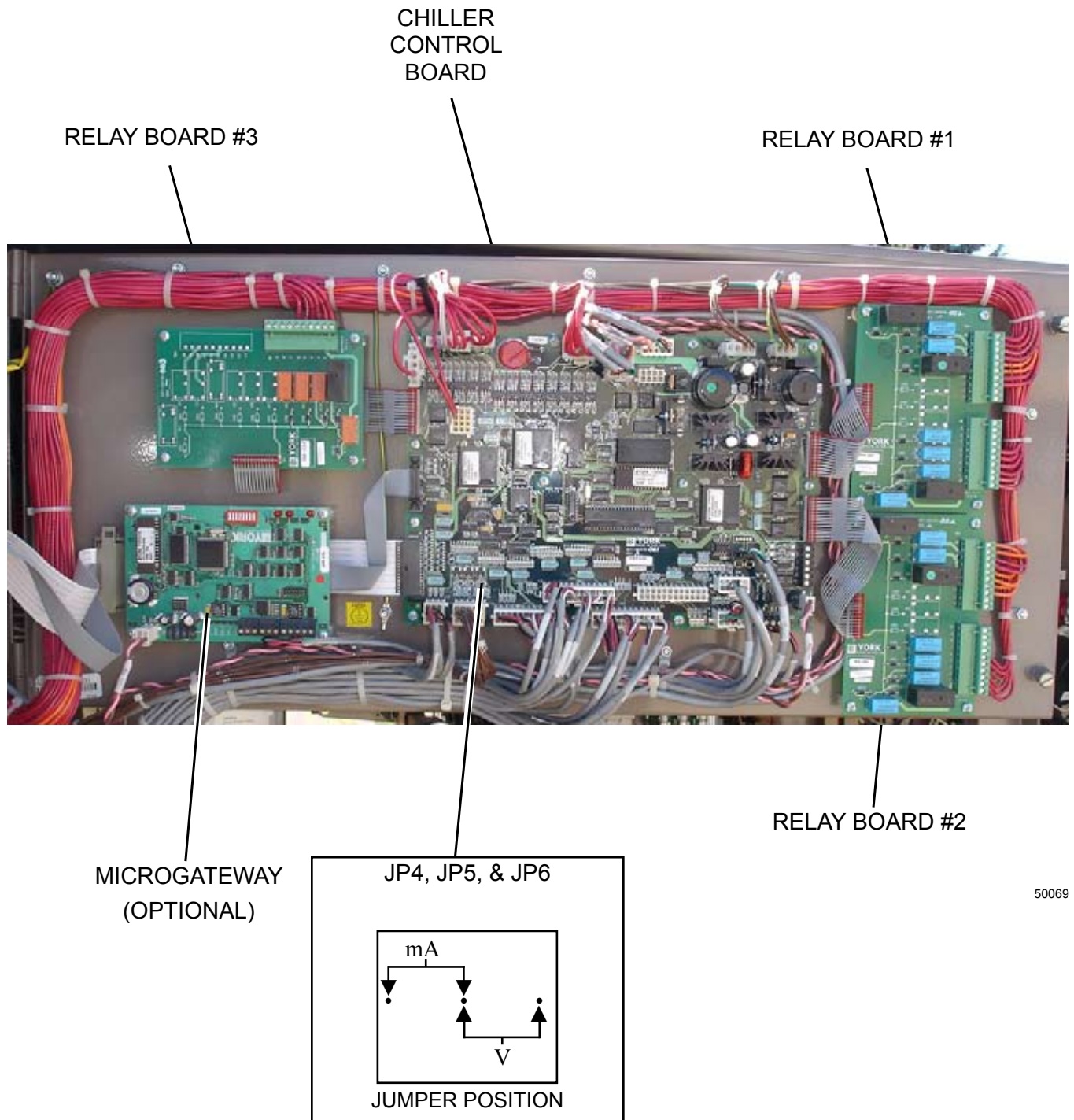

6

50069

FIG. 27 - CHILLER CONTROL BOARD, RELAY BOARDS, AND MICROGATEWAY, 3 COMPRESSOR

### COMPONENT LOCATIONS (CONT'D)

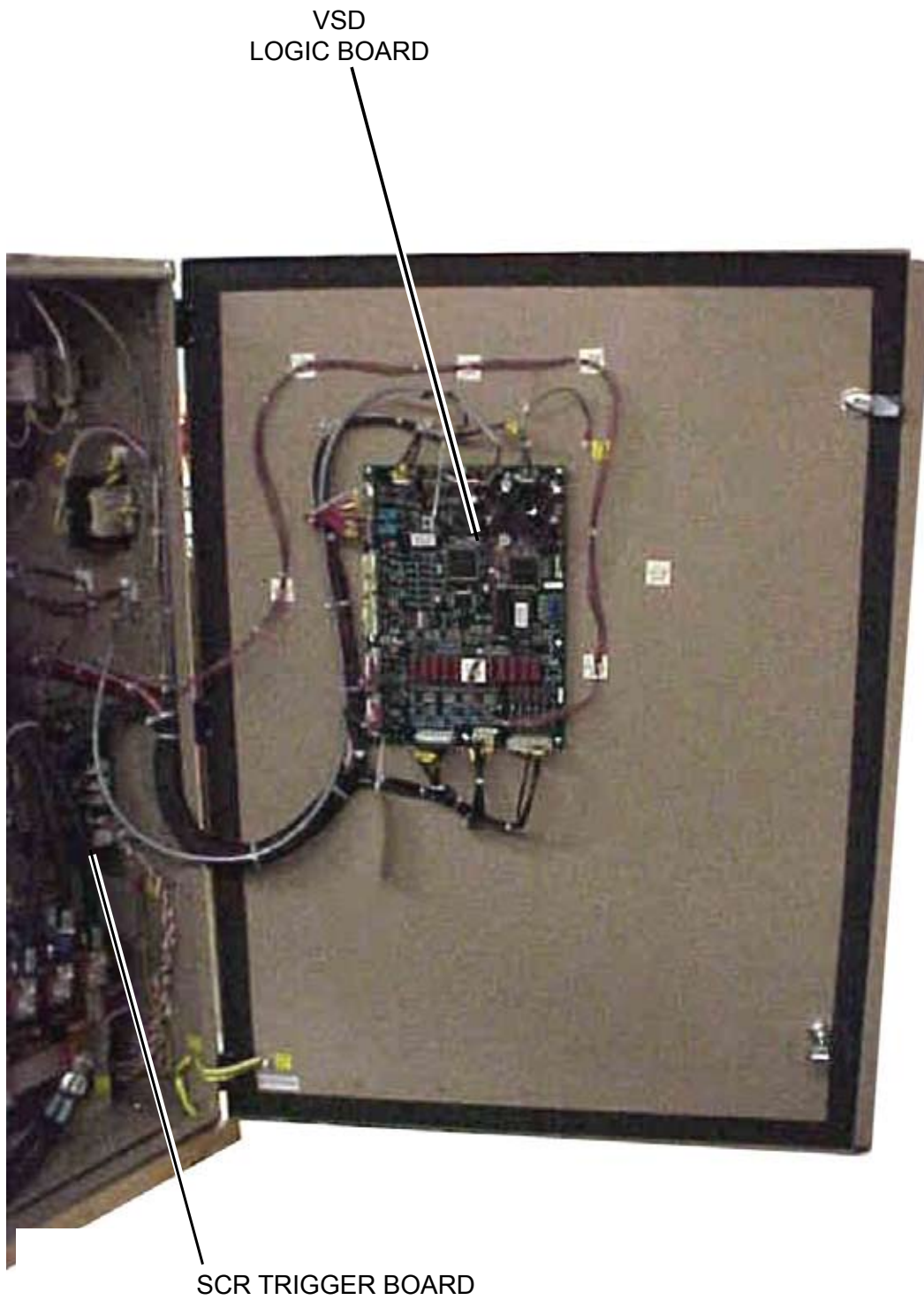

LD10582

FIG. 28 - VSD LOGIC BOARD

# COMPONENT LOCATIONS (CONT'D)

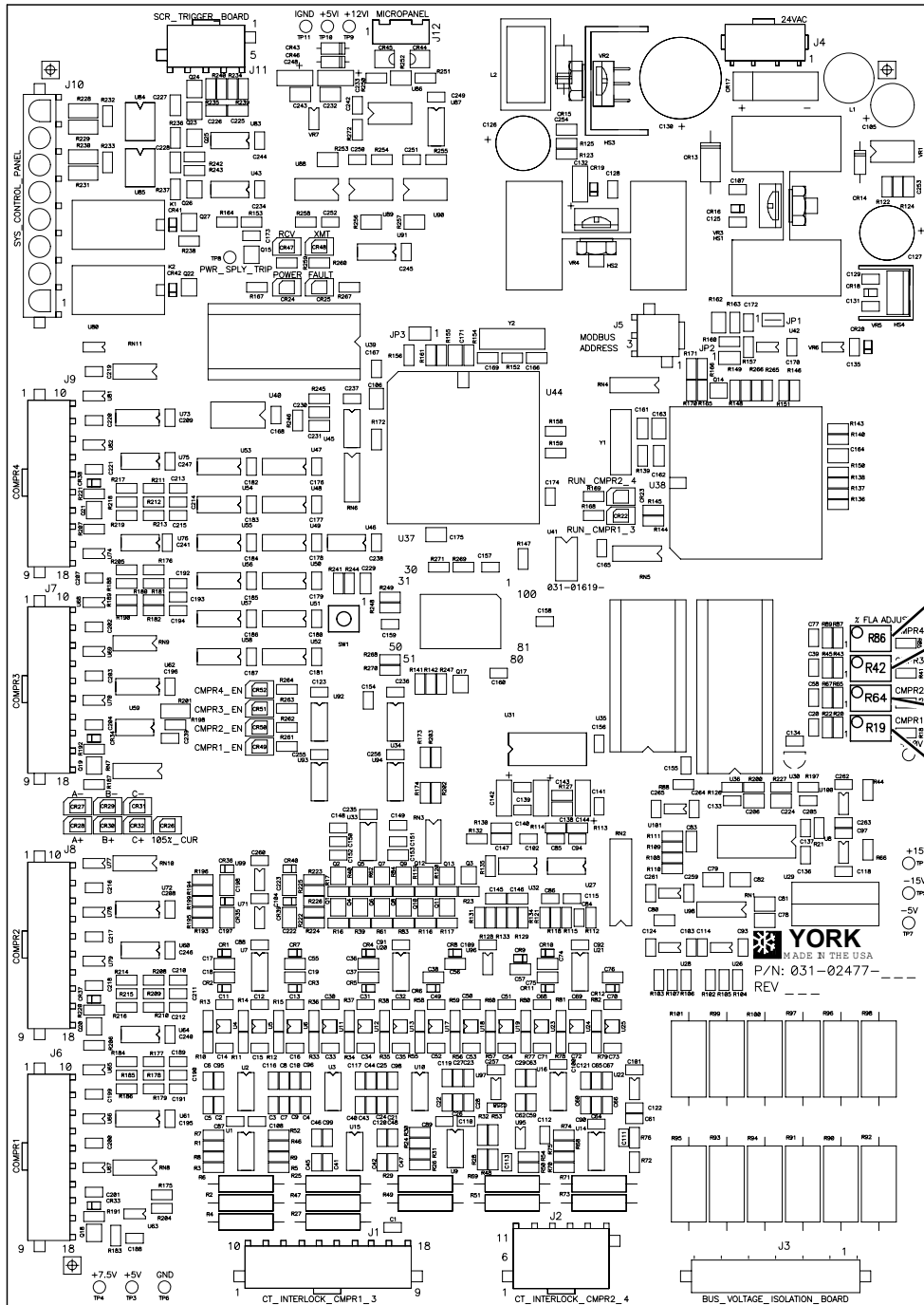

6

- R86  
(COMPR 4  
Over Load Adjust)
- R42  
(COMPR 3  
Over Load Adjust)
- R64  
(COMPR 2  
Over Load Adjust)
- R19  
(COMPR 1  
Over Load Adjust)

FIG. 29 - VSD LOGIC BOARD (ORIGINAL - OBSOLETE), P/N 031-02477-000

COMPONENT LOCATIONS (CONT'D)

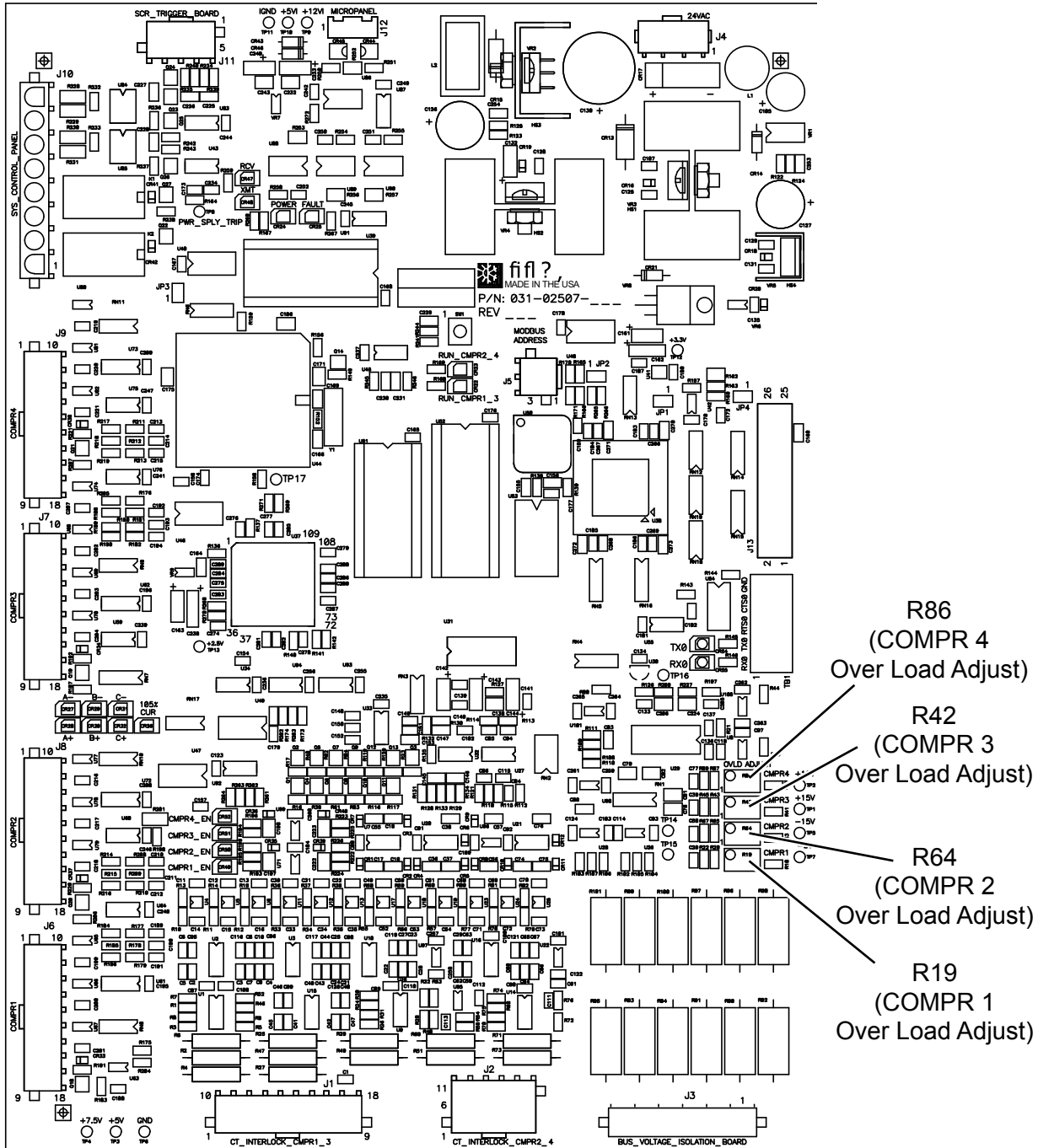

FIG. 30 - VSD LOGIC BOARD (NEW), P/N 031-02507-XXX

### COMPONENT LOCATIONS (CONT'D)

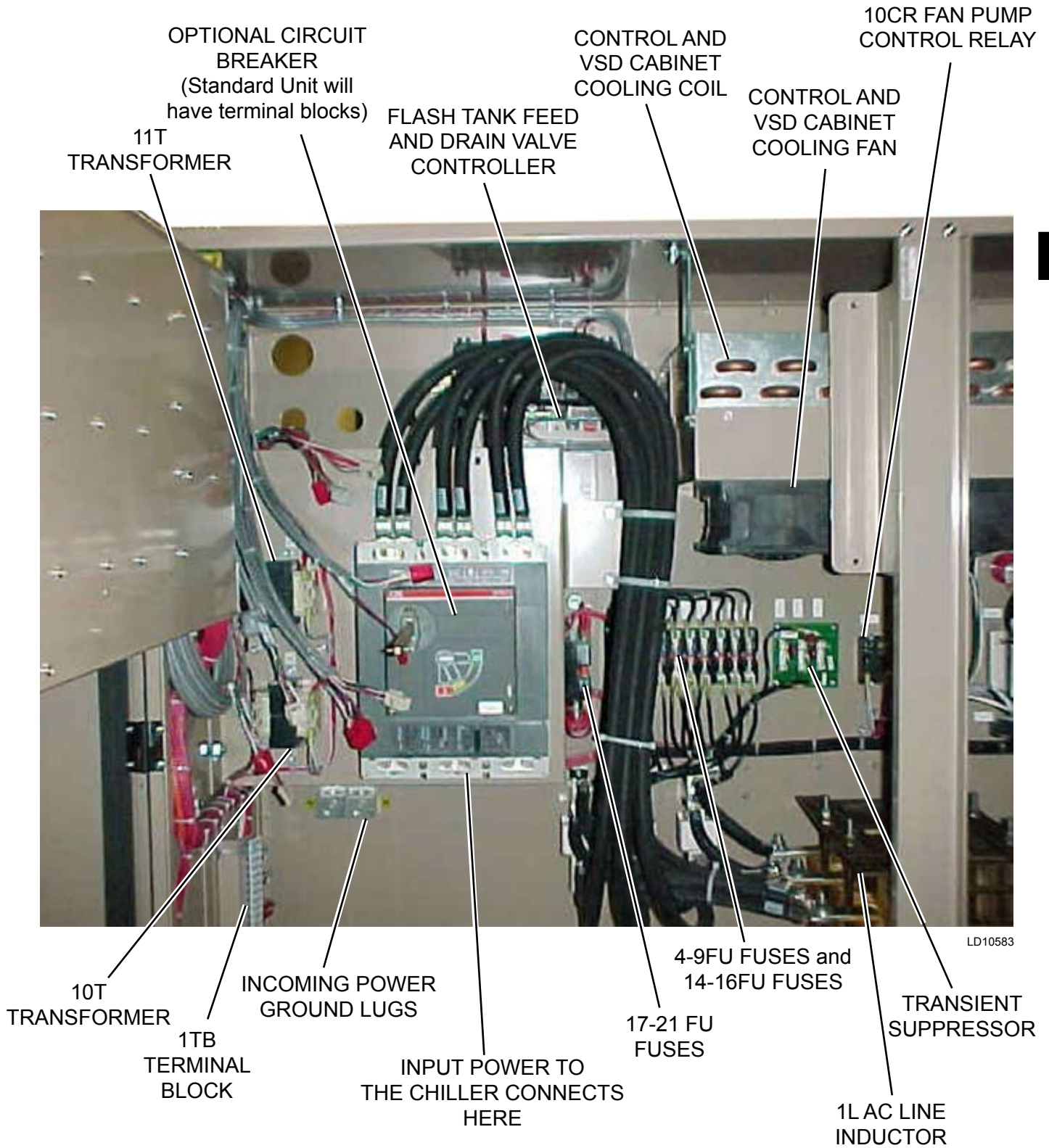

FIG. 31 - POWER COMPONENTS, 2 COMPRESSOR

### COMPONENT LOCATIONS (CONT'D)

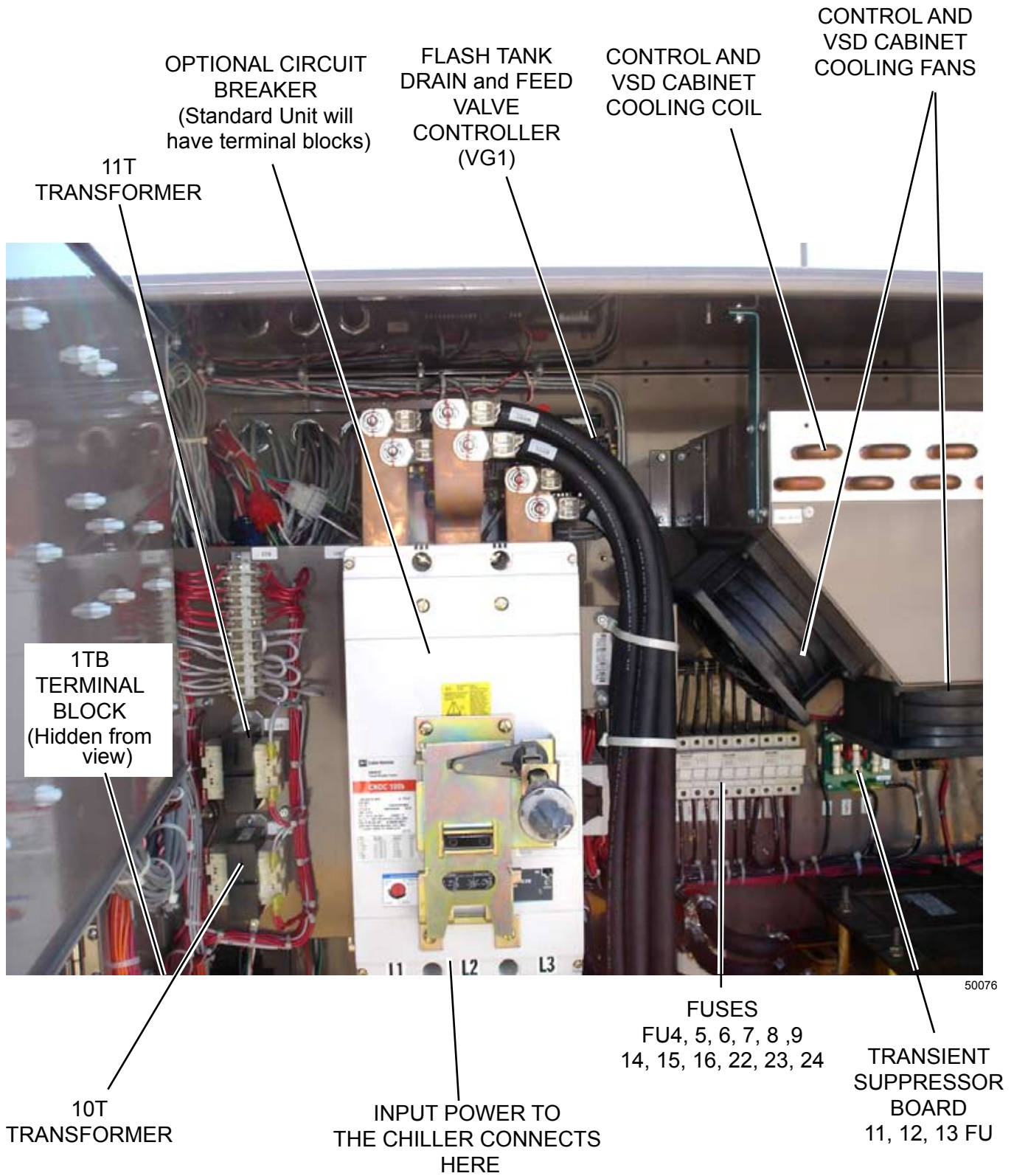
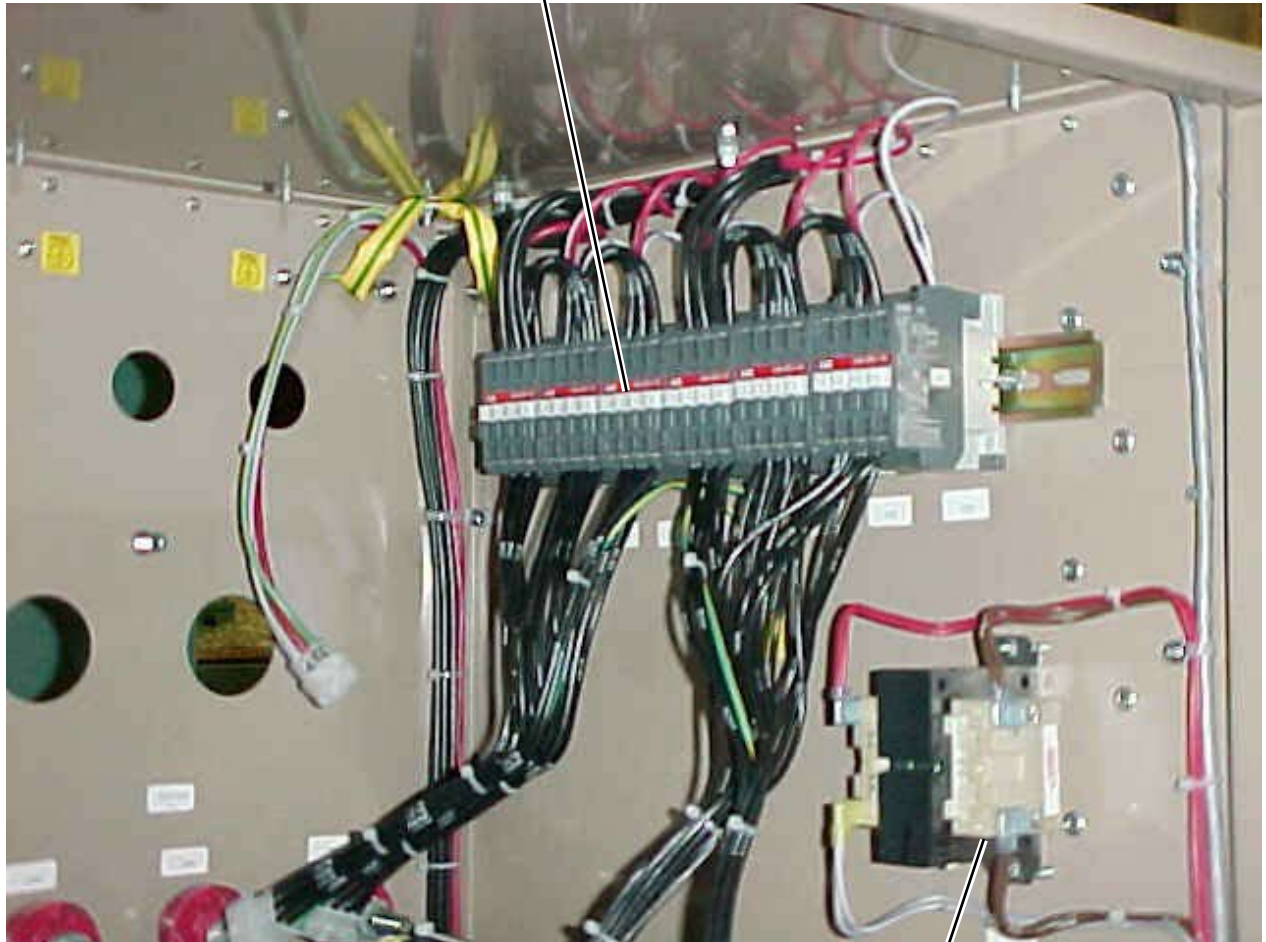

FIG. 32 - POWER COMPONENTS, 3 COMPRESSOR

## COMPONENT LOCATIONS (CONT'D)

FAN CONTACTORS  
4CR-9CR



6

LD10584

3T TRANSFORMER  
(24VAC to SCR Gate Driver Board and VSD Logic Board)

FIG. 33 - FAN CONTACTORS AND 3T TRANSFORMER, 2 COMPRESSOR

### COMPONENT LOCATIONS (CONT'D)

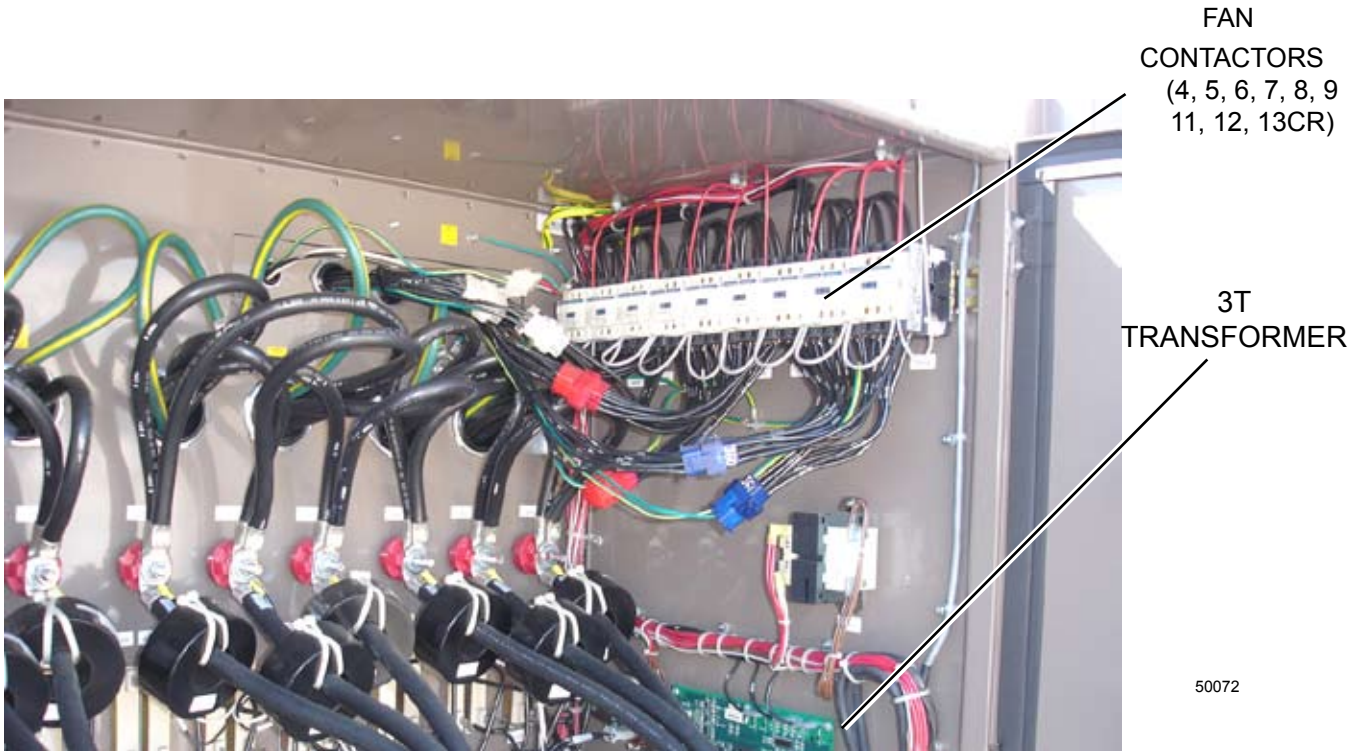

FIG. 34 - FAN CONTACTORS, 3 COMPRESSOR

## COMPONENT LOCATIONS (CONT'D)

17-21 FU FUSES  
(17 FU: 2T, 18 FU: VSD Logic /  
SCR Trigger Board /  
Pump Contactor,  
19 FU: 10T and 11T,  
20 FU: Relay Board #1,  
21 FU: Relay Board #2

TRANSIENT  
SUPPRESSOR BOARD  
(3-Phase Input)

4-9 FU FUSES and  
14-16 FU FUSES  
(4-6 FU: TB-1-3 SCR  
Trigger Board,  
7-9 FU: Sys. 1 Fans,  
14-16 FU: Sys. 2 Fans)

4-6 CT  
CURRENT  
TRANSFORMERS

3-8 RES RESISTORS  
(Motor Output RC  
"DV/DT" Network)

COOLING  
FAN

COOLING  
FAN

10 CR FAN PUMP  
CONTROL RELAY

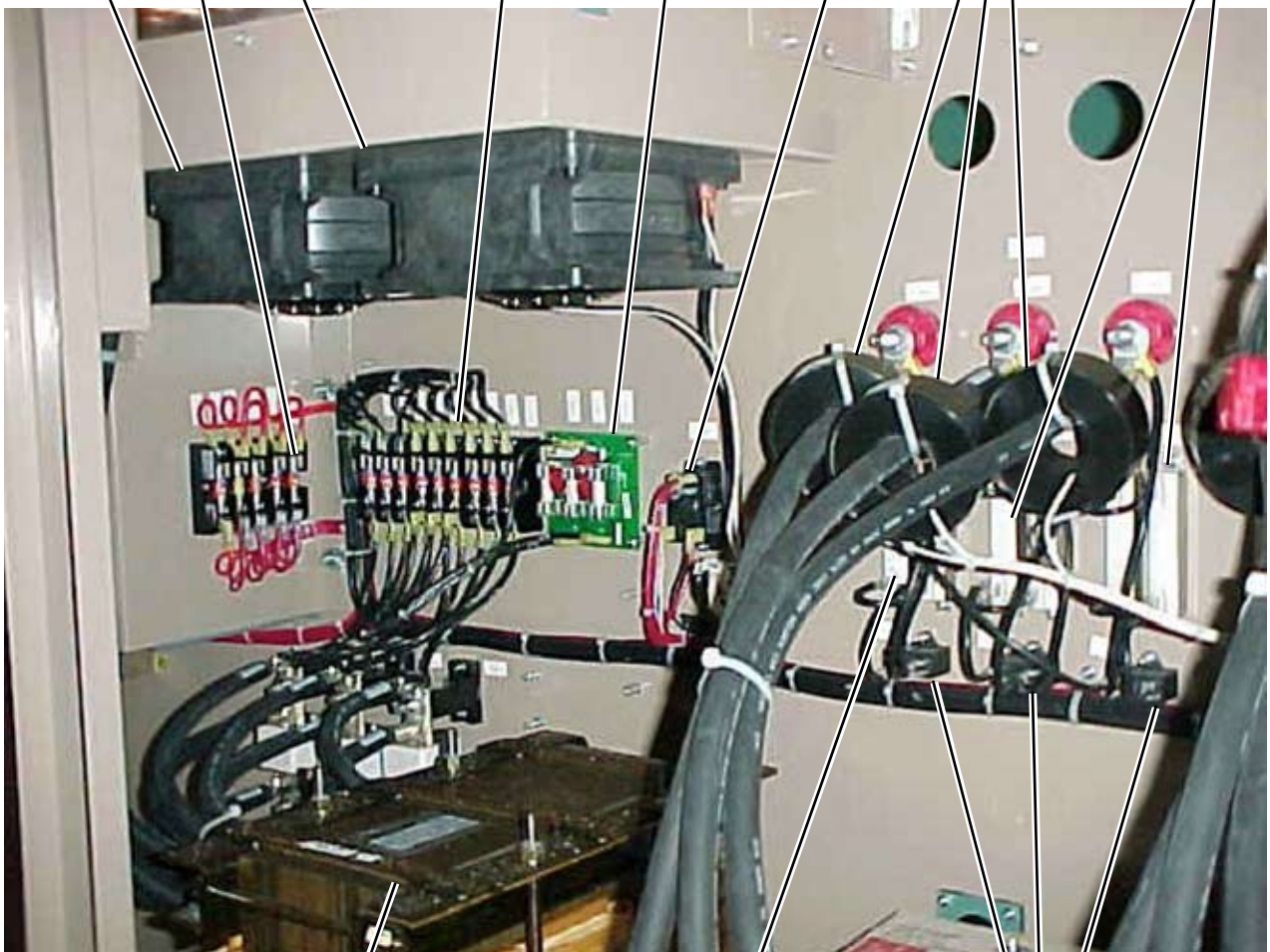

6

1L AC LINE  
INDUCTOR

3-8 RES RESISTORS  
(Motor Output RC  
"DV/DT" Network)

CAPACITORS C15-C17  
(Motor Output RC "DV/DT"  
Network)

LD10585

FIG. 35 - VSD COMPONENTS

### COMPONENT LOCATIONS (CONT'D)

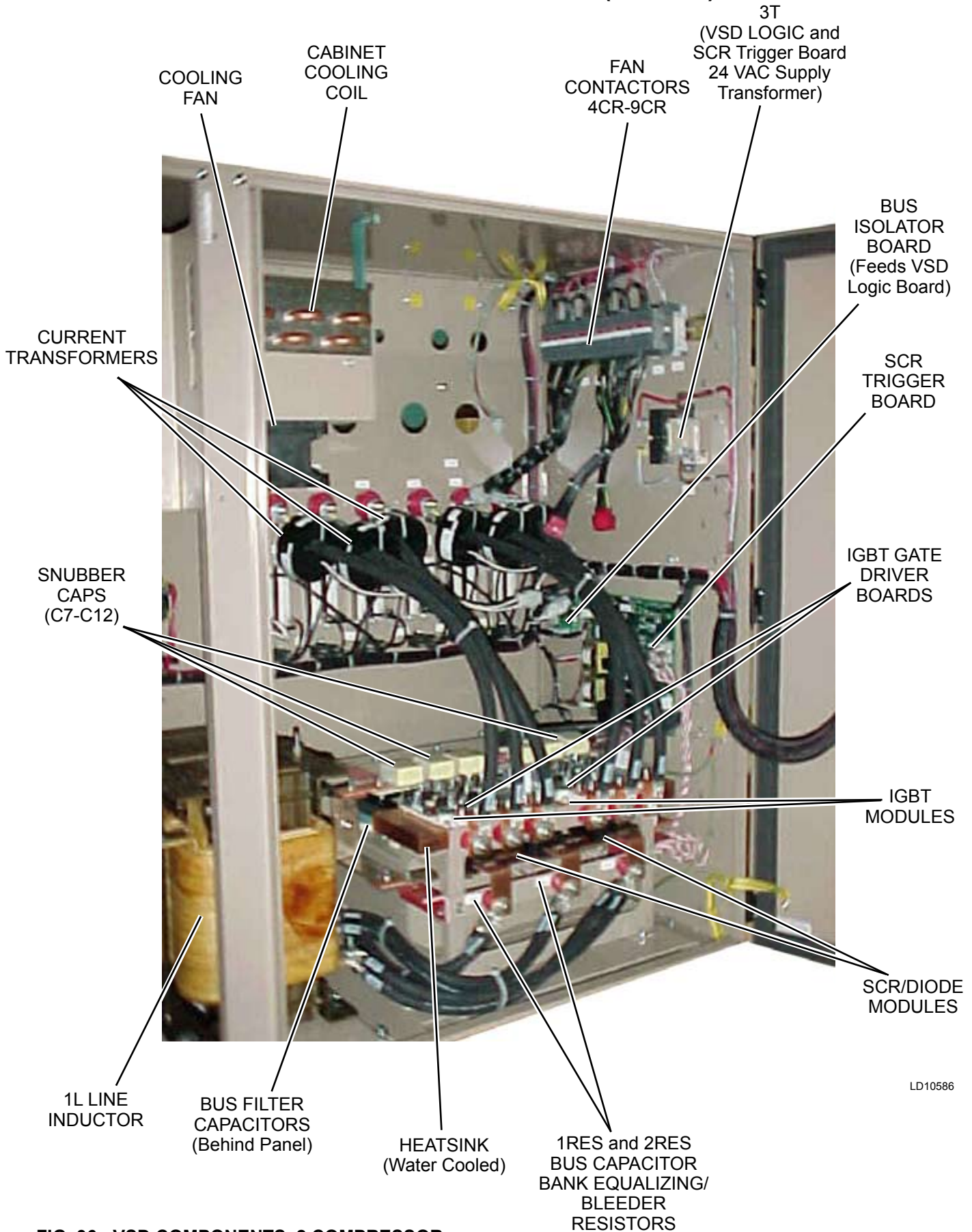

LD10586

FIG. 36 - VSD COMPONENTS, 2 COMPRESSOR

### COMPONENT LOCATIONS (CONT'D)

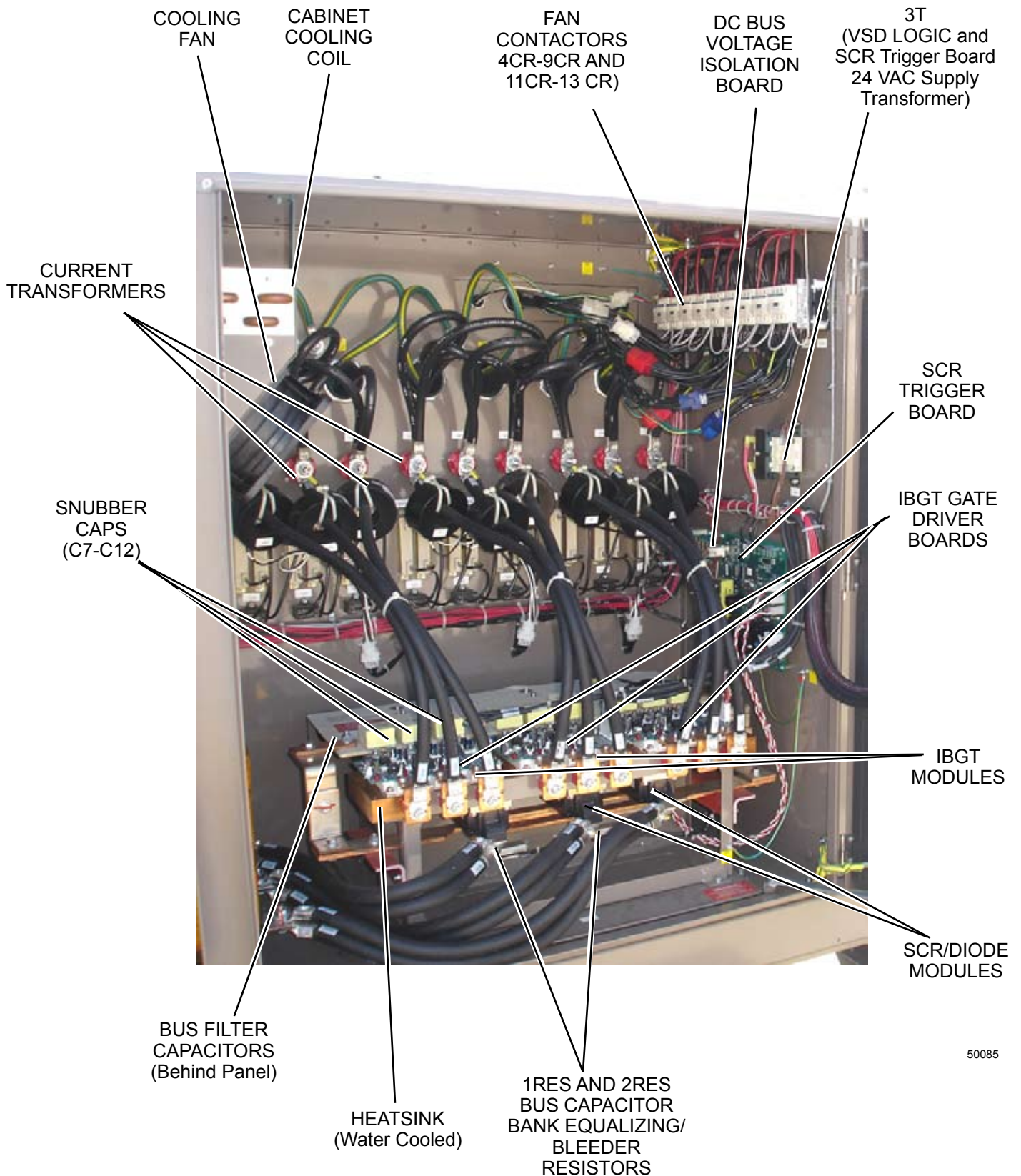
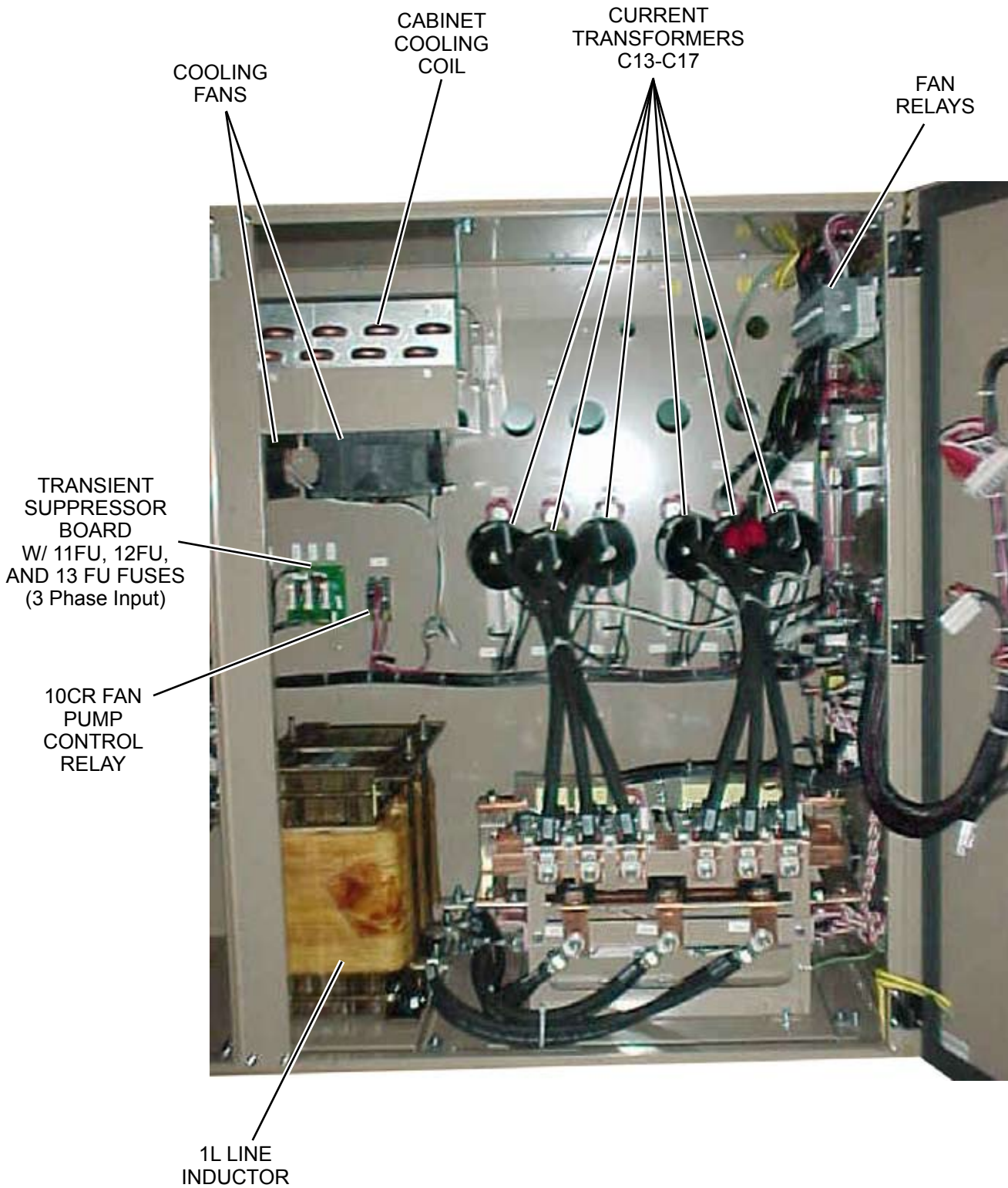

FIG. 37 - VSD COMPONENTS, 3 COMPRESSOR

### COMPONENT LOCATIONS (CONT'D)



LD10587

FIG. 38 - VSD COMPONENTS, 2 COMPRESSOR

### COMPONENT LOCATIONS (CONT'D)

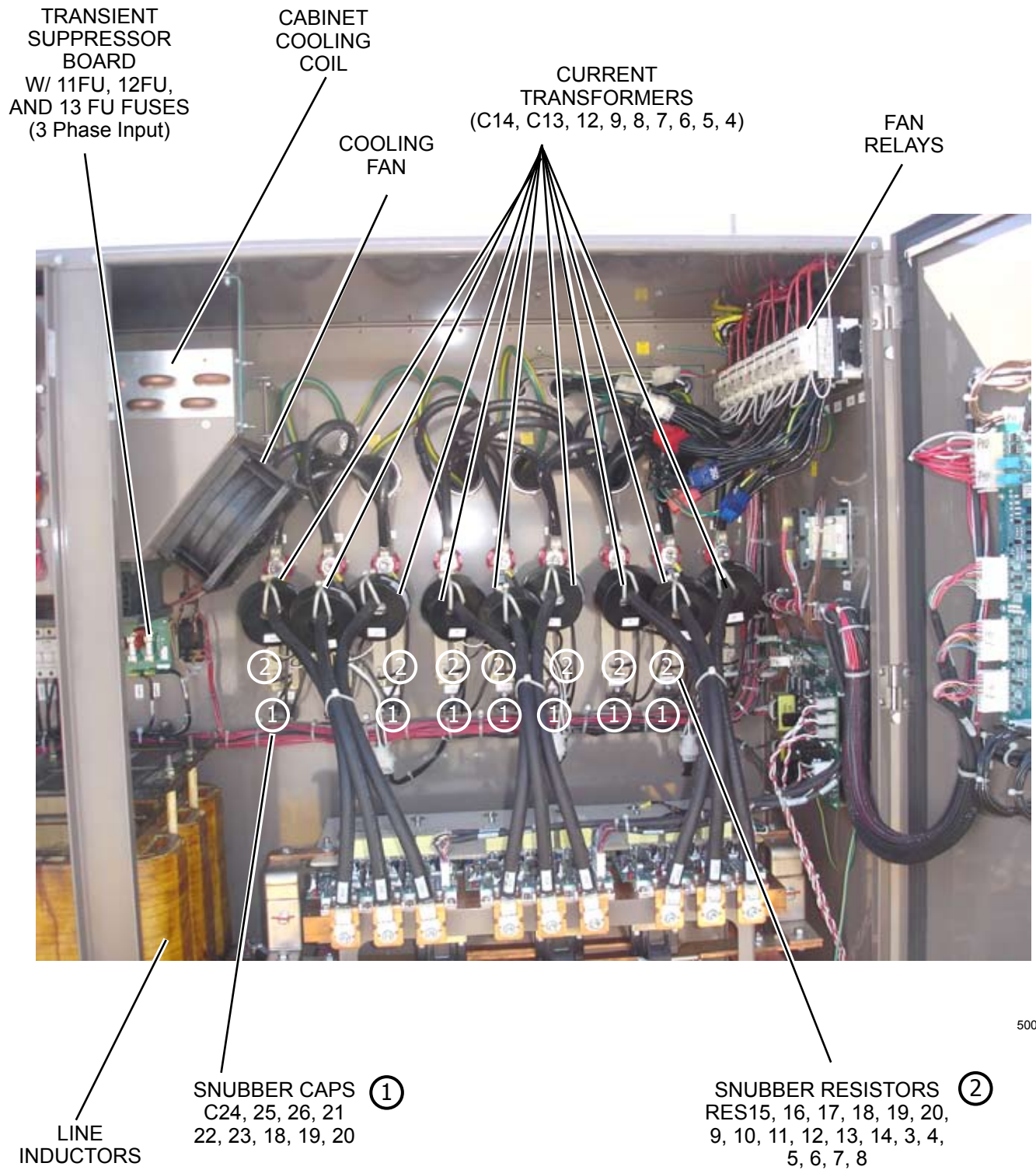

6

50073

FIG. 39 - VSD COMPONENTS, 3 COMPRESSOR

COMPONENT LOCATIONS (CONT'D)

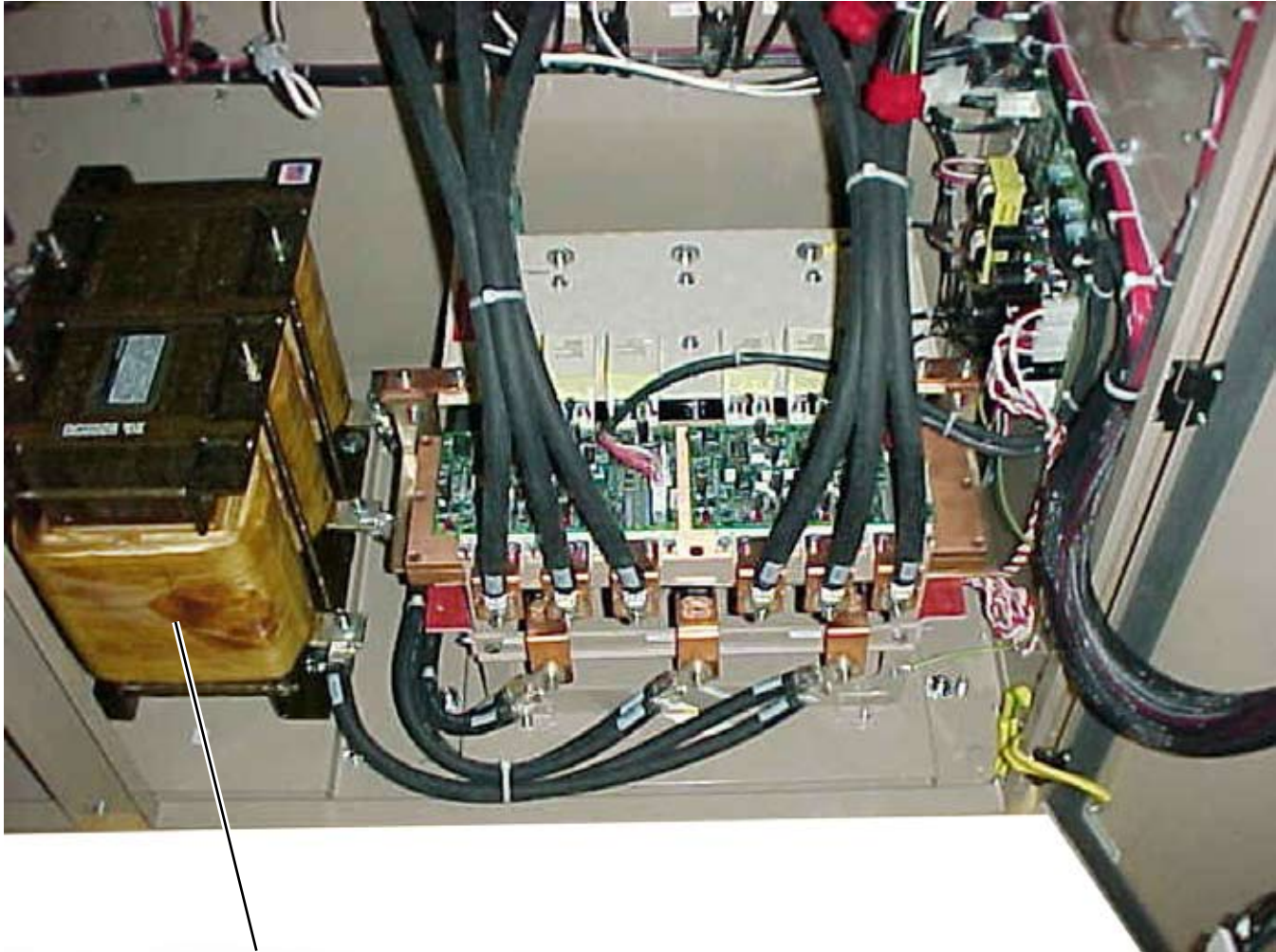

*The line inductor will reach operating temperatures of over 300° F. Do not open panel doors during operation. Assure the inductor is cool whenever working near the inductor with power OFF.*

LD10588

FIG. 40 - INVERTER POWER COMPONENTS, 2 COMPRESSOR

### COMPONENT LOCATIONS (CONT'D)

SCR  
TRIGGER  
BOARD



50077

FIG. 41 - INVERTER POWER COMPONENTS, 3 COMPRESSOR

### COMPONENT LOCATIONS (CONT'D)

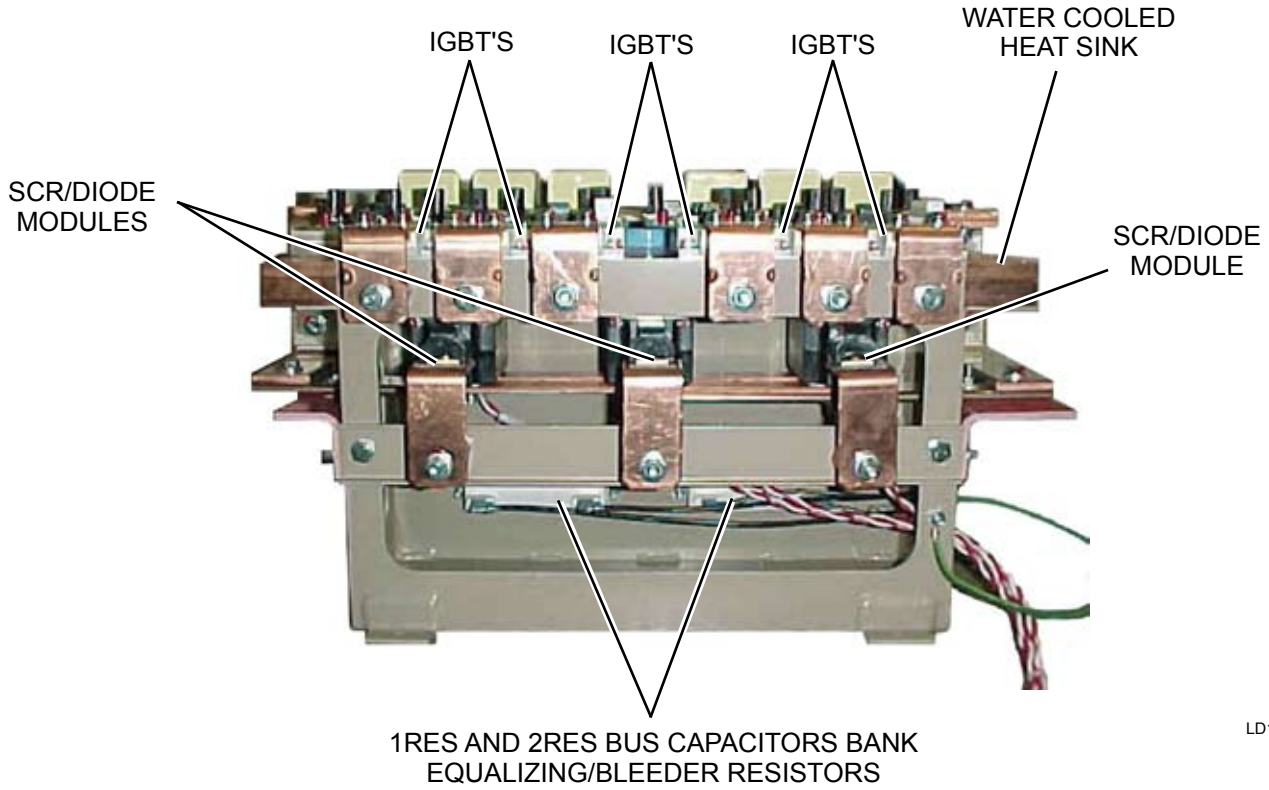

LD10591

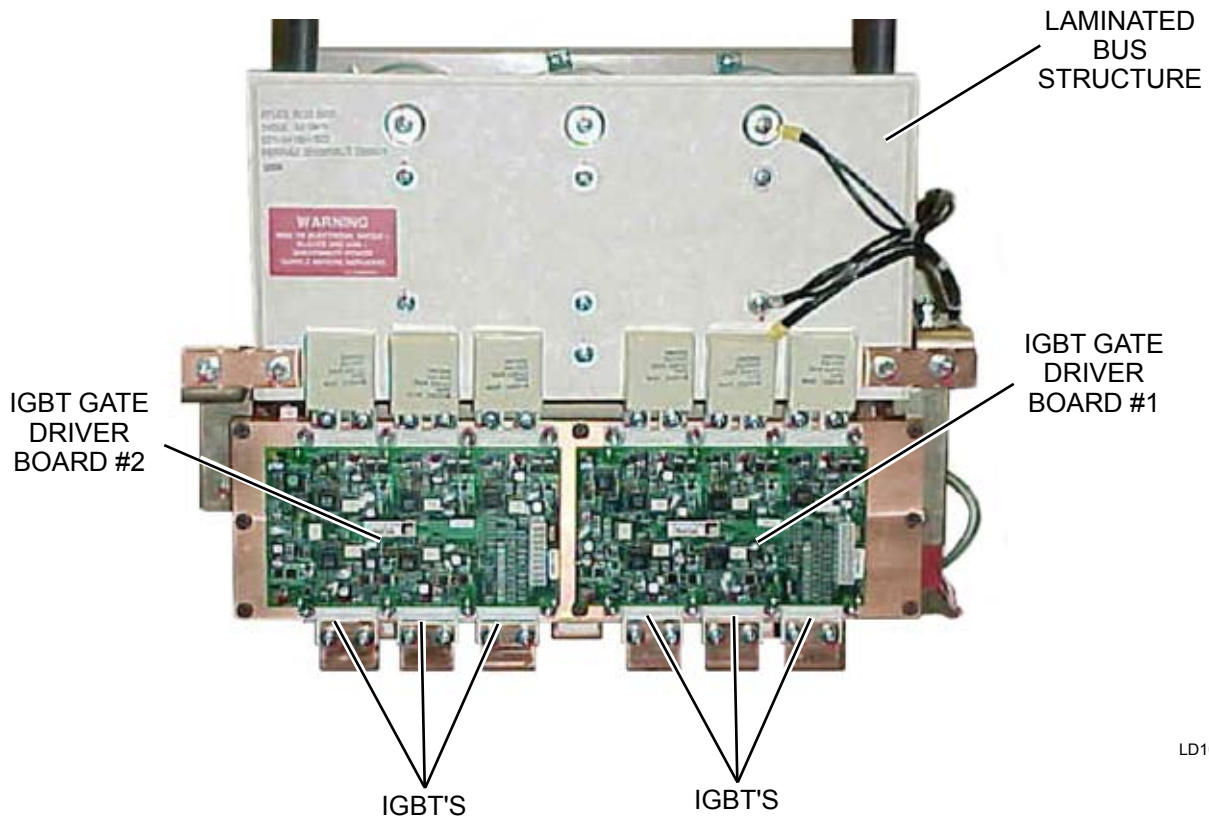

LD10592

FIG. 42 - INVERTER POWER COMPONENTS

### COMPONENT LOCATIONS (CONT'D)

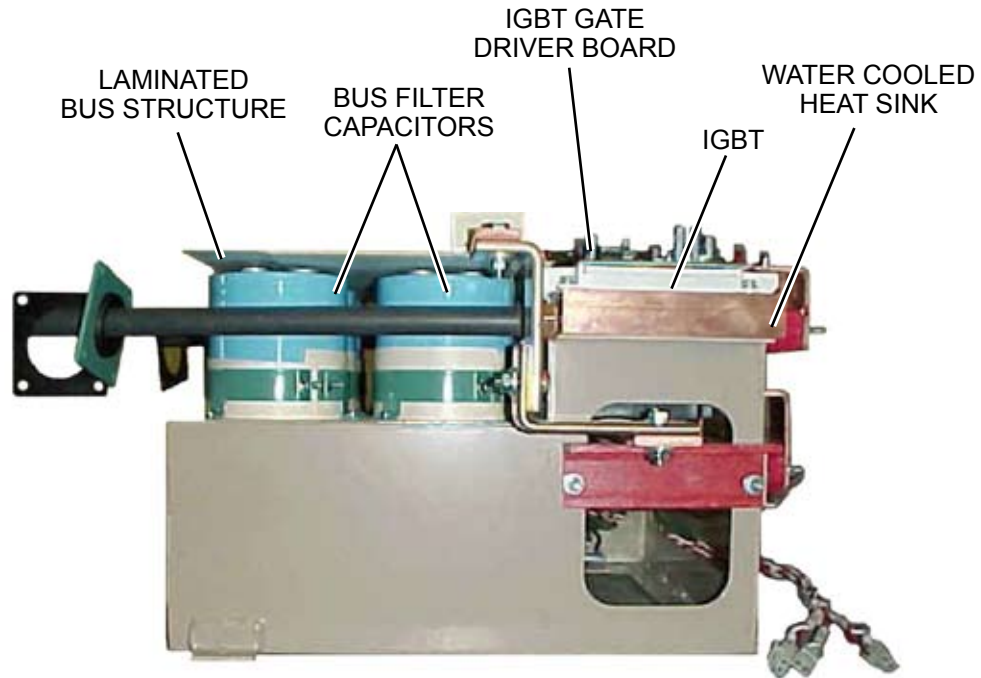

6

LD10593

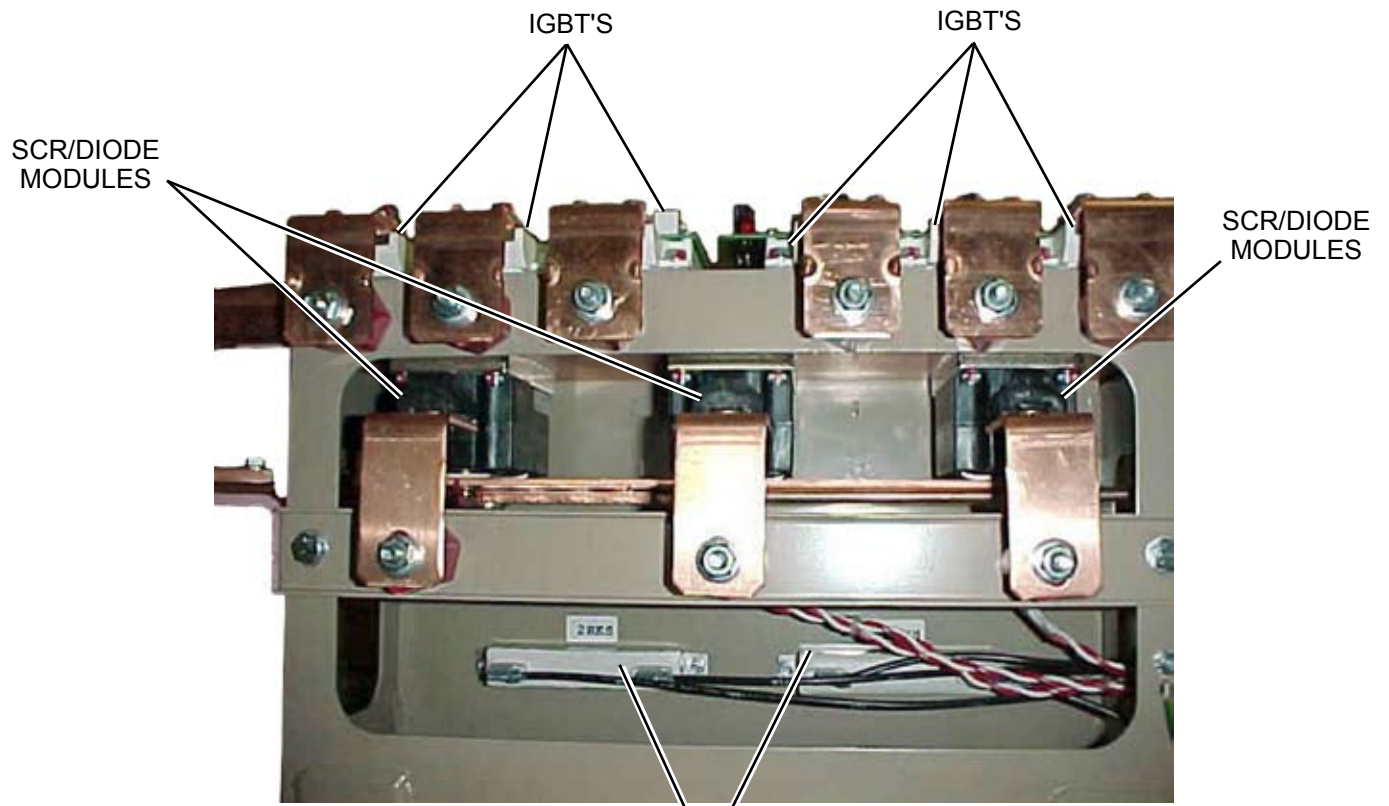

LD10594

**FIG. 42 - INVERTER POWER COMPONENTS (CONT'D)**

### GLYCOL SYSTEM COMPONENTS

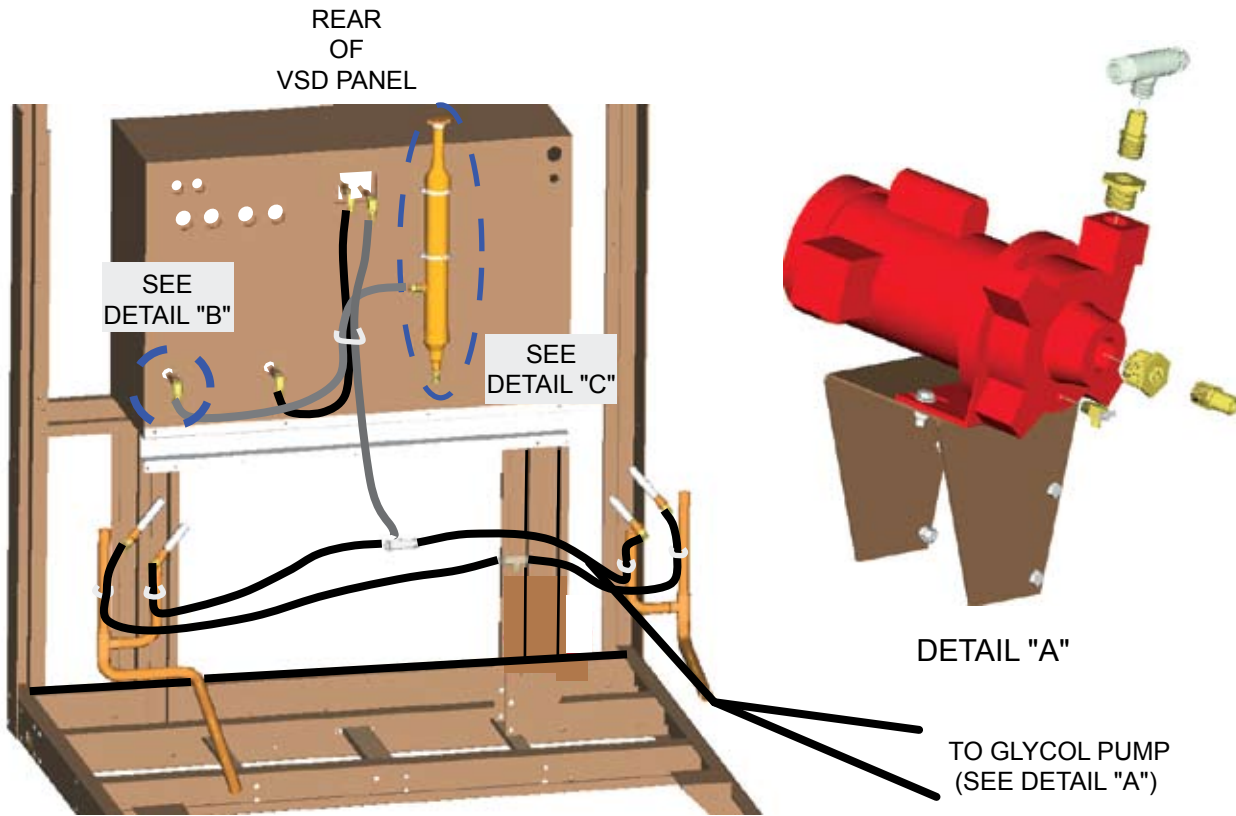

LD13122A

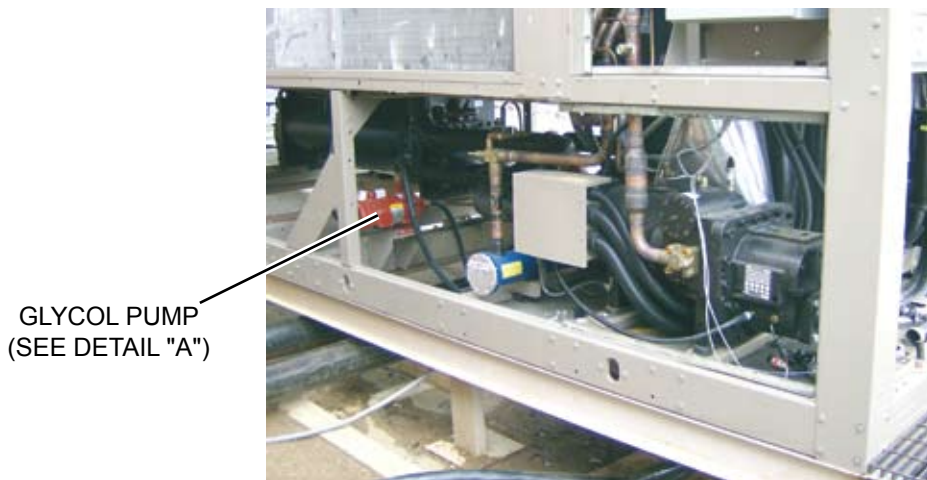
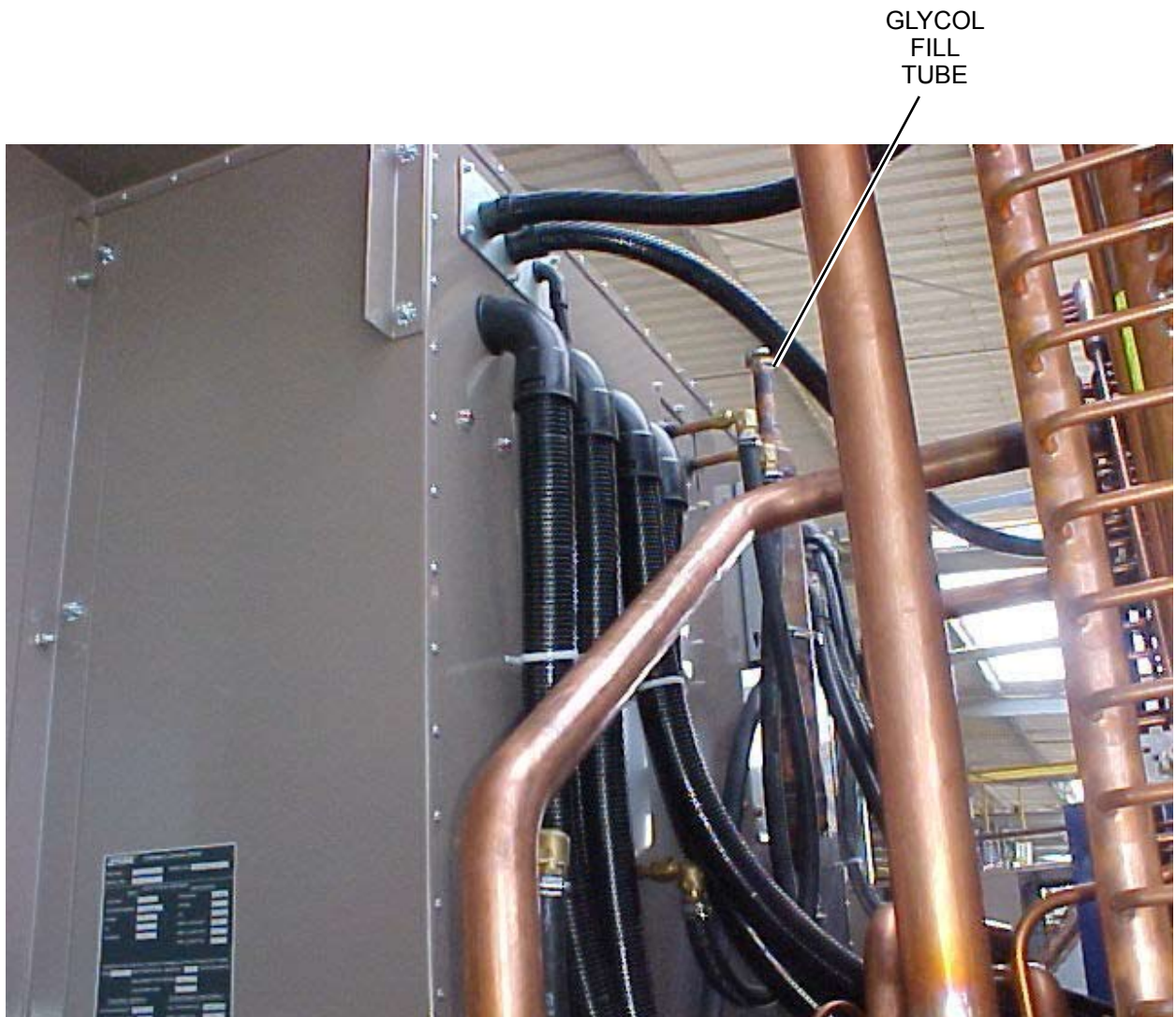

FIG. 43 - GLYCOL PUMP & FILL TUBE LOCATIONS

## GLYCOL SYSTEM COMPONENTS (CONT'D)



6

LD10597

FIG. 44 - GLYCOL PIPING AND FILL TUBE LOCATION

# COMPRESSOR COMPONENTS

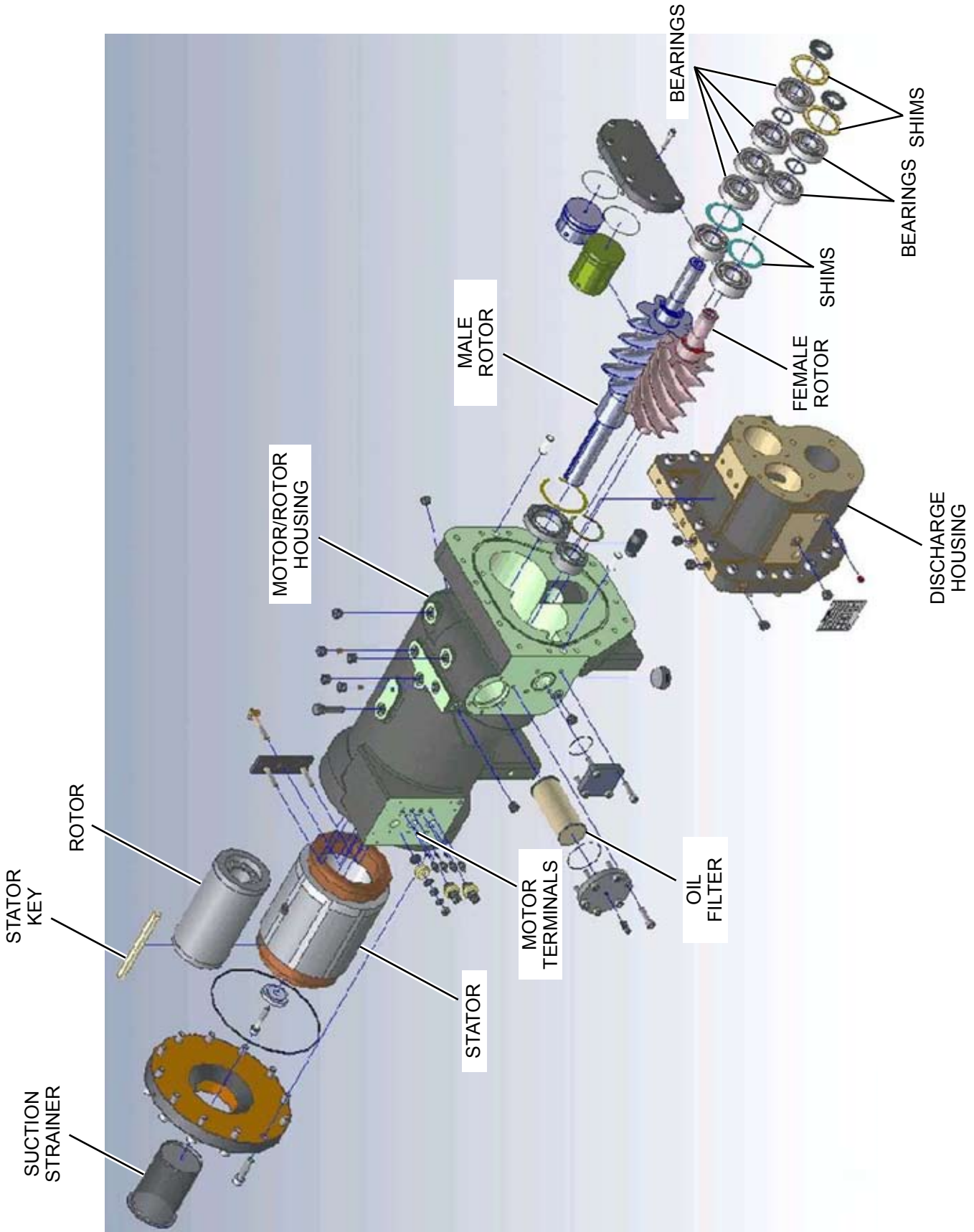

FIG. 45 - COMPRESSOR COMPONENTS

LD10596

## CHILLER ELECTRONIC COMPONENTS

### Keypad

An operator keypad allows complete control of the system from a central location. The keypad offers a multitude of command keys on the left and right side of the keypad to access displays, program setpoints, history data, and initiate system commands. Most keys have multiple displays that can be accessed by repetitively pressing the key or by pressing the ▲, ▼, ◀, and ▶ (ARROW) keys. The keypad utilizes an overlay to convert the keypad to various languages.



LD10605

The keypad also contains keys in the center section for data entry in the various program modes. These keys are listed below:

- 0-9 Keys NUMERIC KEYPAD
- • PERIOD/DECIMAL
- +/- PLUS/MINUS
- ✓ ENTER
- × CANCEL
- ▲ UP ARROW
- ▼ DOWN ARROW
- ◀ LEFT ARROW
- ▶ RIGHT ARROW

The numeric keys allow keying numeric values into memory.

The • (PERIOD/DECIMAL) key allows keying a decimal point into numeric values.

The +/- (PLUS/MINUS) key allows making numeric values negative.

The ✓ (ENTER) key stores program changes into memory.

The X (CANCEL) key is used to cancel the data entry operation and returns the programmed value to the original value, before any programming changes were made, when an error is made.

The ▲ (UP ARROW) and ▼ (DOWN ARROW) keys allow scrolling backward (▲) and forward (▼) through items to be programmed under keys such as the PROGRAM or OPTIONS key.

The ▲ (UP ARROW) and ▼ (DOWN ARROW) keys also allow scrolling forward (▼) or backwards (▲) through data display keys that have multiple displays under keys such as UNIT DATA, SYSTEM DATA, HISTORY, PROGRAM, OPTIONS, etc. The arrow keys can be used instead of repeatedly pressing the data key to see the multiple displays under a key. Once the ▲ ▼ (ARROW) keys are pressed and used for scrolling, pressing the original data key will return to the first display message displayed under the data (UNIT DATA, SYSTEM DATA, etc.) keys.

The ◀ ▶ (LEFT and RIGHT ARROW) keys allow scrolling between non-numeric program choices under the OPTION, DATE/TIME, and SCHEDULE keys.

The ◀ (LEFT ARROW) key allows programming the default value when programming numeric values. For changing numeric values, the ▶ (RIGHT ARROW) key has no function.

The ◀ ▶ (ARROW) keys also allow scrolling sideways between the same displays on different systems. For example, Pressing the ▶ (RIGHT ARROW) key while viewing the system #1 suction pressure moves the display to system #2 suction pressure.

Pressing the ◀ (LEFT ARROW) key moves the opposite direction. The arrow keys also allow fast scrolling through data under keys such as HISTORY by enabling the operator to move between subgroups of data such as Unit, System, and VSD data.

**Keypad Data Entry Mode**

For numeric programmable items, the data entry mode is entered by pressing any of the number keys, the decimal point key, or the +/- key. When the data entry mode is entered, the data from the key press will be entered and the cursor will appear under the position where the data is being entered.

For non-numeric programmable items, data entry mode is entered by pressing the ◀ or ▶ (ARROW) keys. When the data entry mode is entered, the cursor will appear under the first position of the non-numeric string. The programmable choice may be changed by pressing the ◀ or ▶ (ARROW) keys.

To exit the data entry mode and store the programmed value, the ✓ (ENTER) key must be pressed. When the ✓ (ENTER) key is pressed, the cursor will disappear.

The data entry mode may also be exited by pressing the X (CANCEL) key. The programmed data will be returned to its original value when the X (CANCEL) key is pressed.

When the data entry mode is exited, the cursor will disappear. If any other key is pressed while in the Data Entry Mode, the following display will appear for 2 seconds indicating the user must choose between accepting or canceling the change:



If the ✓ (ENTER) key was pressed from the data entry mode and the numeric value entered was out of range, the following message will appear for 2 seconds followed by the original data display.



**Display**

The 80 character (2 lines of 40 characters per line) display is a Liquid Crystal Display (LCD) used for displaying unit parameters, system parameters, and operator messages. The display has an LED backlight background for night viewing and is viewable in direct sunlight.

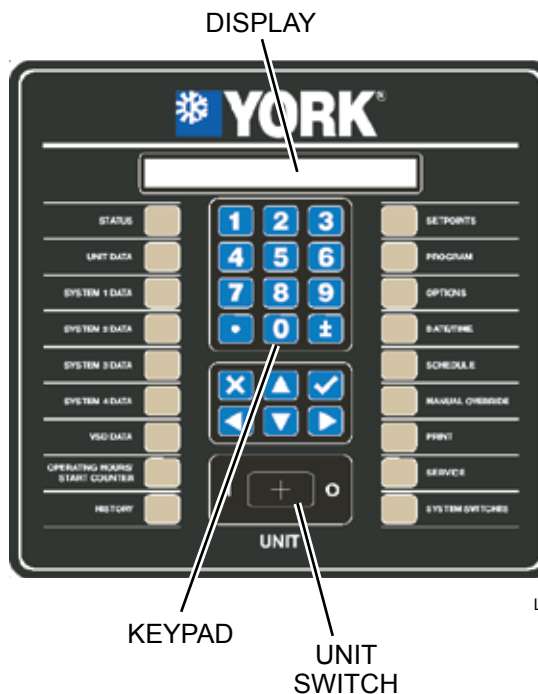

LD10605

**Chiller Control Board**

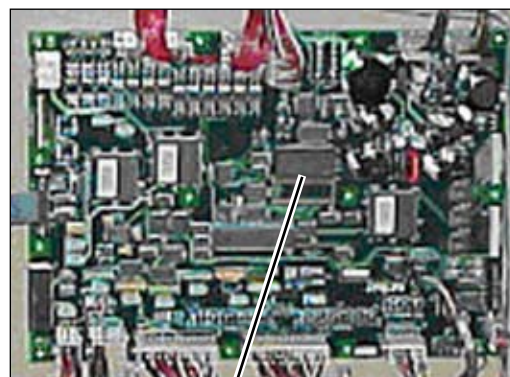

LD10606

RTC

The Chiller Control Board is the controller and master decision maker in the control panel. The on-board microprocessor control is capable of controlling up to 4 compressors. System inputs from pressure transducers and temperature sensors are connected directly to the Chiller Control Board. The Chiller Control Board circuitry multiplexes all of the analog inputs, digitizes them, and scans the inputs to keep a constant watch on chiller operating conditions. Based on this information, the Chiller Control Board issues

commands to the Relay Output Board(s), Drain/Feed Valve Controller, and VSD Logic Board to activate and de-activate contactors, solenoids, control valves, set compressor speeds, etc., for chilled liquid and safety control. keypad commands are acted upon by the Chiller Control Board microprocessor to change setpoints, cutouts, scheduling, operating requirements, and to provide displays.

The Chiller Control Board contains a Real Time Clock integrated circuit chip with an internal battery backup of 8K x 8 bit RAM. The purpose of the battery backed RAM is to assure any programmed values (setpoints, clock, cutouts, history data etc.) are not lost during a power failure, regardless of the time involved in a power outage or shutdown period.

The Chiller Control (Microprocessor) Board contains an onboard power supply, which provides 5VDC regulated to sensors, transducers, display, and other circuit boards. The supply also provides +12VDC to the Relay Output Boards and the +34VDC to the level sensors.

The Chiller Control Board is capable of directly receiving analog inputs from temperature sensors and transducers. An analog to digital converter (A/D) with an onboard 4 channel multiplexer (MUX) allows up to 48 analog inputs to be read. The A/D Converter converts the analog signals to digital signals, which can be read by the onboard microprocessor. On a 2 system chiller, approximately half of these inputs are utilized.

Three integrated circuits on the microprocessor can be configured for digital inputs or outputs (Digital I/O). As inputs, they can read digital (2 level, on/off) inputs like keypad keys, unit switch, high pressure cut-out, flow switch, etc. As outputs they are used for controls like turning on fans, controlling compressor heaters, controlling chiller valves, or other devices requiring ON/OFF control. Up to 72 Digital I/O will be utilized to control the chiller.

The Chiller Control (Microprocessor) Board contains a dual UART (Universal Asynchronous Receiver Transmitter) for RS-485 and RS-232 communications. UART1 is configured for RCC and ISN communications on the external chiller RS-485 port. Data is sent and received at 4800 baud with 1 start bit, 8 data bits, odd parity, and 1 stop bit. The port is shared with the RS-232 interface and at start-up will be initialized to

RS-485 communications. UART2 is configured for VSD communications over an internal chiller RS-485 port located within the Control/Power cabinet. UART2 has a higher priority interrupt than UART1. The data is sent and received at a rate of 9600 baud and serves only as the communications between the Chiller Control Board and the VSD Logic Board. Both of these boards are located within the control/power panel.

On power-up, the Chiller Control Board will attempt to initialize communications with the VSD Logic Board. The Chiller Control Board will request the number of compressors select and VSD software version. If for some reason the information is not provided, the request will be made over and over again until it is received. Once the data has been received, the Chiller Control Board will not ask for it again. If the communications is not established, a VSD Loss Of Comms fault message will appear on the STATUS display.

Two 8 channel, 8 bit Digital to Analog Converters (D/A Converter) on the Chiller Control Board supply the Feed and Drain Valve Controller signals to allow the controller to position the Flash Tank Feed and Drain Valves. The Feed Valve controls the refrigerant level in the flash tank while the Drain Valves controls superheat. The control voltage to the Feed and Drain Valve Controller has a range of 0 to 10.28VDC.

### Relay Output Boards



LD10607

Two or three Relay Output Boards are required to operate the chiller. These boards convert 0 to 12VDC logic levels outputs from the Chiller Control Board to 115VAC levels used by contactors, relays, solenoid valves, etc., to control system and chiller operation.

The common side of all relays on the Relay Output Board is connected to +12VDC.

The open collector outputs of the Chiller Control Board energize the DC relays on the Relay Output Board by pulling one side of the relay coil to ground. When not energized, both sides of the relay coils will be at +12VDC potential.

**VSD (Variable Speed Drive)**

The VSD is a liquid cooled, transistorized, PWM inverter packaged within the Control/Power cabinet. The inverter is composed of four major sections:

- AC to DC rectifier section with precharge circuit.
- DC link filter section.
- Three phase DC to AC inverter section.
- Output RC suppression network.

**AC to DC Rectifier**

The AC to DC Rectifier circuit utilizes a semi-converter made of three SCR/diode modules in a three phase bridge configuration. Each SCR/Diode module contains 1 SCR and 1 diode. The modules are mounted on a liquid cooled heatsink. This circuit rectifies the incoming AC voltage to unfiltered DC, which is filtered by the DC Link Filter.

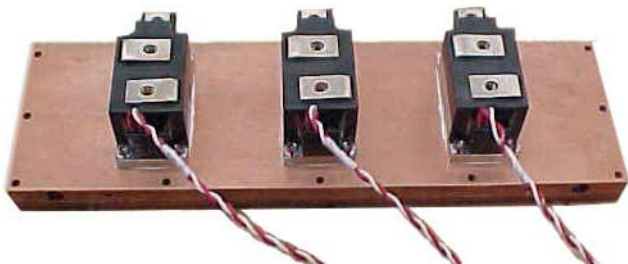

LD10608

A semi-converter (combination SCR/Diode) configuration allows utilizing a separate pre-charge circuit to limit the current in the DC link filter capacitors when the VSD is first switched on. This is accomplished by slowly turning on the SCR's to initially charge the DC Bus. Once charged, the SCR's remain fully gated on during normal operation. This configuration also provides a fast disconnect from main power when the drive is switched off.

When the drive is called to run (leaving chilled liquid temperature is more than the Setpoint plus CR), the SCR/Diode modules are turned on by the SCR trigger board, allowing the DC link filter capacitors to slowly precharge for a period of 20 seconds.

The AC incoming line voltage is rectified by the full three phase semi-converter bridge, made up of three SCR/Diode modules, which provides pulsating DC to the DC link Filter in the VSD.

**SCR Trigger Board**

The SCR Trigger Board controls the firing (gating) sequence of the Bridge SCR's.



LD10609

Command for the SCR Trigger Board to begin firing the SCR's is initiated by the VSD Logic Board.

The SCR Trigger Board also monitors the three phase input voltage to detect the loss of an incoming phase.

**DC Link Filter**

The DC Link Filter consists of a bank of electrolytic filter capacitors. The capacitors smooth (filter) ripple voltage resulting from the AC to DC rectification and provides an energy reservoir for the DC to AC inverter. The capacitor filter bank is made up of 2 banks of parallel-connected capacitors wired in series. Series banks of capacitors allow using smaller sized capacitors with lower voltage ratings.

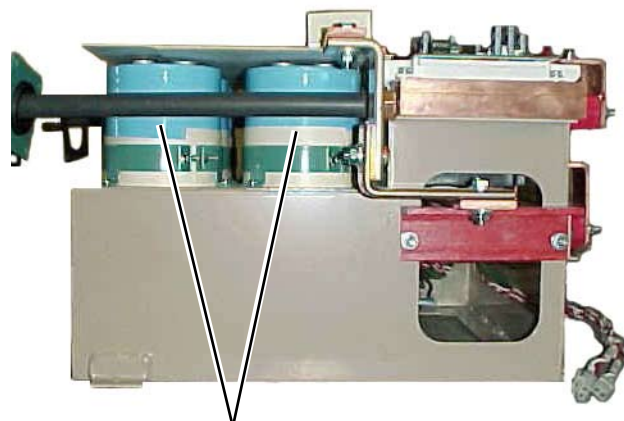

FILTER CAPACITORS

LD10610

The capacitor bank in conjunction with the 1L Line Inductor forms a low pass LC Filter and provides further smoothing (filters ripple) to the rectified DC.

Equalizing/Bleeder resistors connected across the banks equalize the voltage between the top and bottom capacitors to avoid damaging the capacitors from over voltage. The Equalizing/Bleeder resistors also provide a path for discharge of the capacitors when the drive is switched off. This safely discharges the capacitors in approximately 5 minutes. Always be careful, a bleeder resistor could be open and the bus may be charged.



LD10611

EQUALIZING/BLEEDER  
RESISTORS



***When servicing, always check the DC Bus Voltage across the top and bottom, banks of capacitors with a known functioning voltmeter correctly set to the proper scale before performing service on the inverter. DO NOT rely on the Bleeder Resistors to discharge the capacitor banks without checking for the purpose of safety.***

***NEVER short out a capacitor bank to discharge it during servicing. If a bleeder resistor is open and a capacitor bank will not discharge, immediately contact Johnson Controls Product Technical Support.***

## 1L Line Inductor

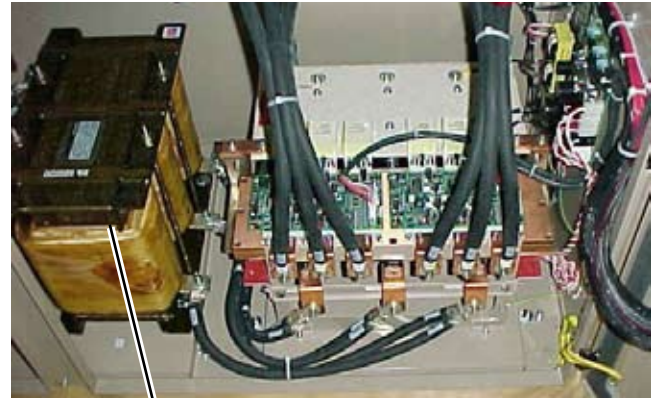

LD10612

1L LINE INDUCTOR

The 5% impedance 1L Line Inductor has multiple functions. 1L forms a low pass LC filter that filters the pulsating DC from the AC to DC converter, to smooth DC voltage. The inductance eliminates notches on the incoming AC line. The inductance also helps protect the SCR's from high voltage incoming line transients, which could damage them. 1L slows down the rate of rise of current if an internal short circuit occurs, reducing the potential damage caused by the short. 1L also reduces the input current total harmonic distortion.

## DC to AC Inverter

The DC to AC Inverter section converts the rectified and filtered DC back to AC at the equivalent magnitude and frequency to run a compressor at a specific speed. Although a common DC Bus links the compressor drive outputs, each compressor has its own inverter output module. Each inverter output module consists of 6 IGBT's (3 modules) and an IGBT Gate Driver Board, which converts DC to a 3 - phase AC output. The IGBT's are mounted to the liquid cooled heatsink designed to take the heat away from the devices and remove it in the condenser. The IGBT Gate Driver Board provides gating pulses to turn the IGBT's ON and OFF.

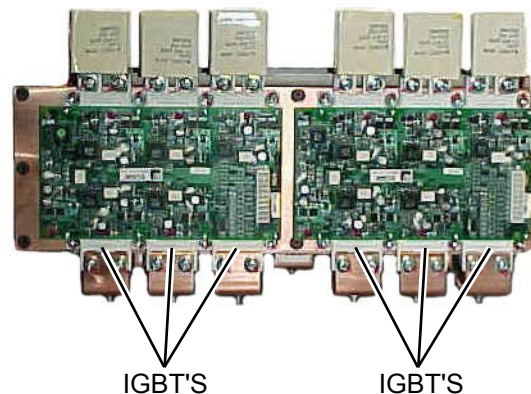

LD10613

IGBT'S

IGBT'S

**Laminated Bus Structure**

The Laminated Bus Structure is a group of copper plates sandwiched together that connects the SCR/Diode Modules, Bus Filter Capacitors, and IGBT's. The purpose of the Laminated Bus Structure is to reduce the inductance that would be present in wiring or bus bars often used to connect high voltage components in VSD's. Removing inductance in the circuit reduces the voltage spike that occurs when the IGBT's turn off. These voltage spikes can potentially damage the IGBT's.

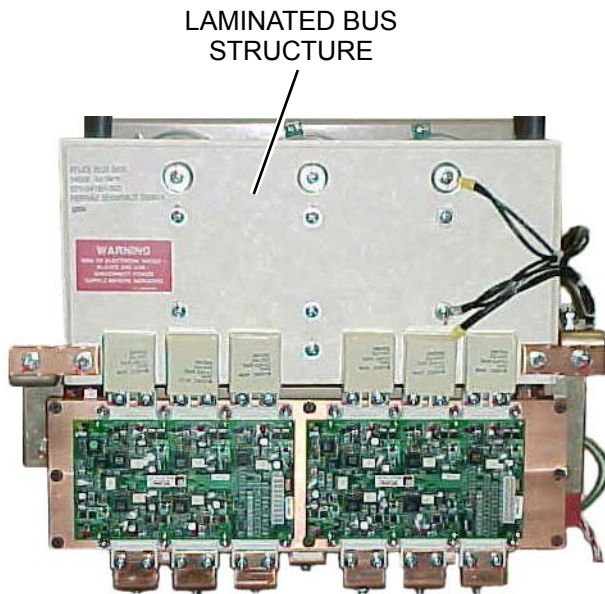

LD10614

**VSD Logic Board**

The VSD Logic Board controls VSD functions/operations and communicates through a serial communications line with the Chiller Control Board. Safety and shutdown information stored in the RTC (Battery backed RAM) is reported back to the Chiller Control Board via the communications link. The VSD Logic Board converts the speed and run commands from the Chiller Control Board into the necessary voltage and frequency commands to operate the inverter section. The VSD Logic Board also controls the converter section of the VSD (AC to DC conversion) by controlling the pre-charge function.

The VSD Logic Board contains a second microprocessor for motor control, which generates the PWM signals that control the IGBT's in the inverter section of the VSD.

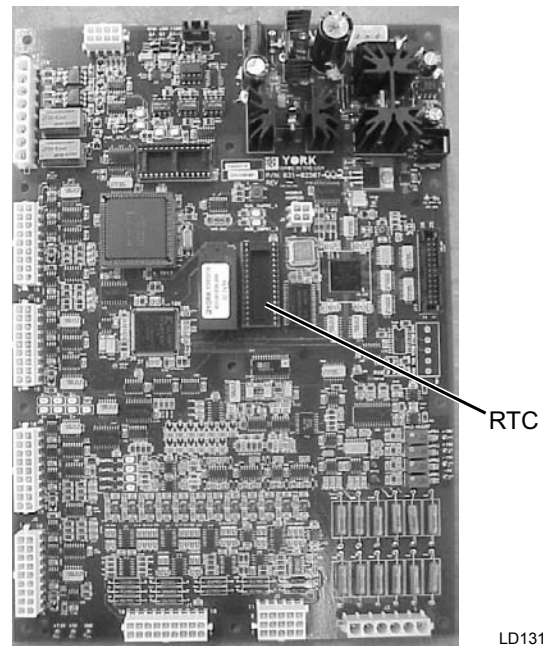

LD13120

**FIG. 46 - NEW BOARD P/N 031-02507-000**

The VSD Logic Board contains an FPGA (Field Programmable Gate Array) which handles the hardware safeties and can shut down the VSD much faster than the software safeties, since they are not dependent upon running program loops in software. The VSD handles all VSD related safeties including high motor current, overload, DC Bus voltage faults, etc.

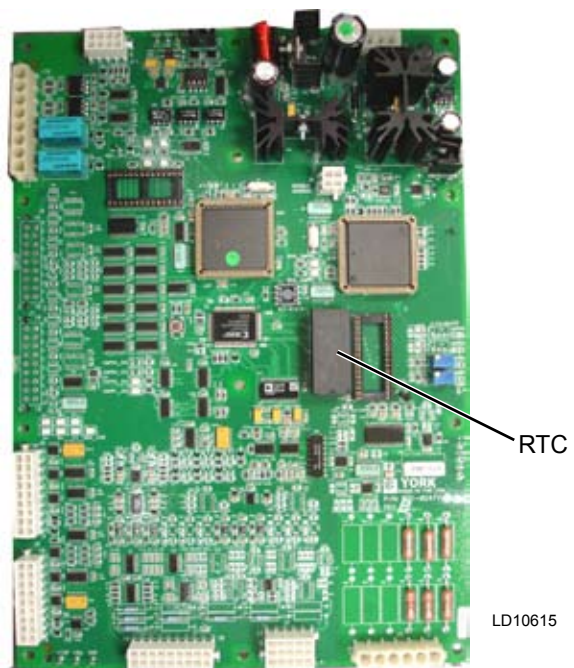

LD10615

**FIG. 47 - OBSOLETE BOARD P/N 031-02477-000**

Inputs to the VSD Logic Board are fed through an onboard multiplexer (MUX) before being sent to the A/D converter. These signals allow the VSD Logic Board to monitor DC Bus voltages, compressor motor currents, VSD internal ambient temperature, IGBT baseplate temperatures, and compressor overload settings.

The VSD Logic Board controls the glycol pump and the cabinet cooling fans. Details on the controls are provided in the “VSD Operation and Controls” section, Page 233.

### Control Panel to VSD Communications

Communication between the VSD Logic Board and the Chiller Control Board is made via a three-wire RS-485 opto-coupled data link. Communications between the two boards occurs at the rate of 9600 baud. UART2 of the dual UART located on the Chiller Control Board is dedicated to internal communications and has a higher priority interrupt than the external communications UART1. The Chiller Control Board will control VSD start/stop, selection of which compressors to run, and compressor speed. The VSD Logic Board will run the desired compressors at the speed requested by the Chiller Control Board. The VSD will report back to the Chiller Control Board, shutdown and safety information related to internal VSD operation and the compressor motors.

On power-up, the control panel will attempt to initialize communications with the VSD. The Chiller Control Board will request initialization data from the VSD Logic Board. The initialization data required is the number of compressors and the VSD software version. Once these data points have been received by the control panel, the unit has successfully initialized and will not request them again.

If the Chiller Control Board does not receive initialization data from the VSD Logic Board in 8 seconds or loses communications with the VSD for 8 seconds at any time, the chiller will fault on a communications failure. The Chiller Control Board will continue to send messages to the VSD Logic Board in an attempt to establish communications while the chiller is faulted.

The VSD Logic Board will also monitor a communications loss. If the VSD Logic Board loses communications with the Chiller Microprocessor Board for 8 seconds at any time, the VSD will shut off all compressors and wait for valid comms from the Chiller Control Board.

Once communications is established, the Chiller Control Board will send a data packet on the data link once every second at 9600 baud. This data packet will include run, stop, and speed commands as well as request operating data from the VSD. Operating data returned by the VSD will include individual motor currents, motor %FLA's, output frequency, compressor motor temperature, and fault information related to internal VSD operating parameters such as DC Bus voltage, IGBT baseplate temperatures, VSD internal ambient, pre-charge relay status, power supply status, run relay status, motor overload, and supply single phase. The Chiller Control Board will poll the VSD Logic Board for information continuously while the chiller is running.

### IGBT Gate Driver Boards

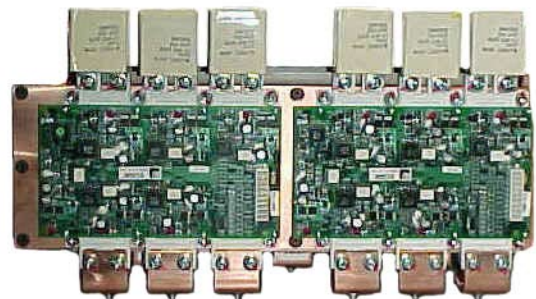

LD10613

The IGBT Gate Driver Boards provide the ON and OFF gating pulses to the IGBT's. The gating signals originate from the VSD Logic Board and are changed in level by the IGBT Gate Driver Board. The IGBT's in the inverter section of the VSD, change the DC Link voltage to a variable Voltage and Frequency output to the motor, to control the compressor motor speed. The IGBT Gate Driver Boards also provides VCE SAT detection (short circuit detection) to safely turn off the IGBT's during a short circuit condition. When a short circuit occurs, the voltage (VCE SAT) across the IGBT increases as a result of the high current. The IGBT Gate Driver Board is an integral part of the IGBT assembly for each compressor.

**Current Transformers**

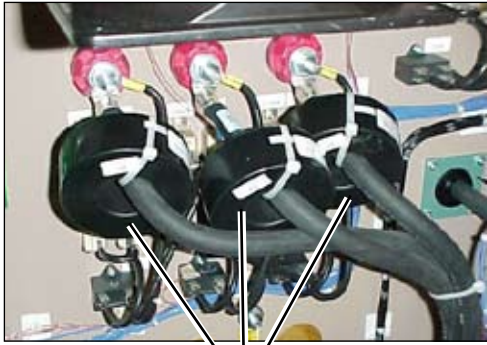

LD10617

**CURRENT TRANSFORMERS**

A current transformer on each phase sends current signals proportional to phase current to the VSD Logic Board. The output of each CT is buffered, scaled, and sent to RMS to DC converters. These signals are then sent to an A-D converter, scaled, and sent to the Chiller Control Board for current display and current limiting control.

The highest current is also compared to the setting of the Overload Adjustment Potentiometer on the VSD Logic Board for overload safety sensing.

**DV/dT Output Suppression Network**



LD10618

**DV/dT RESISTORS**

**DV/dT CAPACITORS**

The dV/dT Output Suppression Network limits the rate of rise of voltage and the peak voltage of the PWM pulses applied to the motor windings. This eliminates the possibility of causing a turn-to-turn short in the motor due to winding insulation breakdown. The suppression network is made up of a 3-phase RC network.

**Flash Tank Feed and Drain Valve Controller**

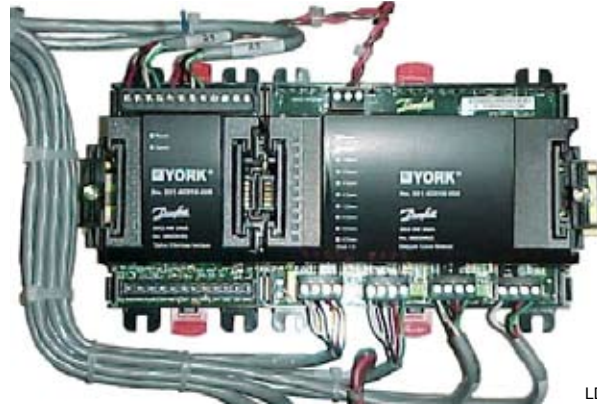

LD10619

The Flash Tank Feed and Drain Valve Controller is a microprocessor driven controller that operates the Feed and Drain Valves based on commands from the Chiller Control Board. The Feed and Drain Valves control the level of liquid in the flash tank and the superheat to the evaporator. The controller is a stand-alone valve control module in the Control/VSD panel. The flash tank liquid level is controlled by sequencing a stepper motor valve (Feed Valve) on the inlet of the flash tank. The controller opens and closes the Feed Valve to control the liquid level of the refrigerant in the flash tank based on commands from the Chiller Control Board. Superheat is controlled by sequencing a stepper motor valve (Drain Valve) on the outlet of the flash tank. The controller opens and closes the Drain Valve to control flow to the evaporator and ultimately superheat to the compressor based on commands from the Chiller Control Board.

Drain Valve superheat control is controlled by a PI control algorithm based on suction pressure and suction temperature in the Chiller Control Board software.

The control algorithms will attempt to control the level in the flash tank to approx 35% when the economizer is energized. If the level exceeds 87.5%, the system will fault. The normal 35% level may fluctuate appreciably when the economizer is off as the flash tank acts as nothing more than a reservoir as the Drain Valve controls superheat. The level will also vary when the economizer is first energized or a system transient occurs such as fan cycling, etc.

The controller is typically located in the back of the panel behind the power wiring terminal block/circuit breaker or on the wall of the panel on the left side of the cabinet.

## DC Bus Voltage Isolation Board



LD10620

The DC Bus Isolation Board allows the VSD Logic Board to read the voltage on the DC BUS without exposing the VSD Logic Board to the high voltage. Instead, the DC Bus Isolation Board contains a resistor network that forms voltage dividers with resistors on the VSD Logic Board, which steps down the voltages so that scaled down voltages proportional to the full and 1/2 bus voltages can be safely fed to the VSD Logic Board. The DC Bus Isolation Board supplies 3 connections to the VSD Logic Board; plus bus, minus bus and half bus.

## Chiller Circuit Breaker



LD10623

An Optional Circuit Breaker may be supplied on the input of the system. The incoming power will be fed to the terminals on the circuit breaker. If the Circuit Breaker Option is not selected, incoming power will be fed to terminal blocks. The breaker also provides ground fault protection. 2 and 3 compressor chillers utilize one circuit breaker, while 4 compressor chillers utilize 2 breakers.

## CHILLER CONFIGURATION JUMPERS

There are a number of chiller configuration jumpers that are factory wired into wire harnesses or plugs. These jumpers typically never need to be reviewed unless in some unlikely situation, a chiller is incorrectly configured or a loose connection occurs.

### Number of Compressors Configuration Jumper

Software packs (EPROM's) are common between 2, 3 and 4 compressor chillers. As a result, the VSD Logic Board must be configured for the actual number of compressors. The chiller is configured for the number compressors through the use of jumpers, factory plugged into the J1 plug on the VSD Logic Board. This hard wiring configures the VSD Logic Board for the number of compressors on the chiller, avoiding mis-programming. The jumpers are only checked at power-up. If no jumpers are sensed, or an invalid combination is sensed and communicated to the Chiller Control Board, start-up of the unit will be inhibited and an "INVALID NUMBER OF COMPRESSORS SELECTED" warning message will be displayed in the Status display.

TABLE 1 shows the chiller number of compressors and the associated location of the jumpers to program the appropriate compressor configuration.

**TABLE 1 - COMPRESSORS AND THE APPROPRIATE JUMPER POSITIONS**

# of COMPRESSORS	VSD LOGIC BOARD JUMPER POSITION
2	J1-10 to J1-9
3	J1-11 to J1-9
4	J1-12 to J1-9

**VSD LOGIC TO CHILLER MICROPROCESSOR BOARD RS-485 COMMUNICATION CONFIGURATION JUMPERS**

The Chiller Control Board and the VSD Logic Boards communicate over an RS-485 link. The communications link requires a matching address to be set up at both ends. The VSD Logic Board communications bus is configured through the use of jumpers, factory plugged into the J5 plug on the VSD Logic Board. The VSD Logic Board will only check the jumper positions once at power-up.

TABLE 2 shows the VSD Logic Board Address configuration and the associated location of the jumpers. The jumpers will vary according to the number of VSD Logic Boards installed. All chillers utilize a single VSD Logic Board and will use VSD Logic Board Address 1.

**TABLE 2 - VSD LOGIC BOARD ADDRESS JUMPER**

VSD LOGIC BOARD's ADDRESS	VSD LOGIC BOARD JUMPER POSITION
1	J5-1 to J5-2 and J5-3 to J5-4
2	J5-3 to J5-4
3	J5-1 to J5-2
4	NONE

**MAXIMUM VSD FREQUENCY/MODEL DESIGNATOR**

The model number of the chiller determines the maximum VSD frequency at 100% full speed. The maximum frequency is programmed by factory installed jumpers on the J7 plug of the Chiller Control Board. Three digital inputs determine a binary code, which determines the maximum frequency. The inputs are read as a 0 or low when a jumper is out or a 1 or high when the wire jumper is inserted between the two pins. The jumpers will only be checked once by the Chiller Control Board on power-up.

TABLE 3 shows the Chiller configuration and the associated location of the jumpers.

**TABLE 3 - MAXIMUM FREQUENCY / MODEL DESIGNATOR JUMPER**

CHILLER CONTROL BOARD MAX. VSD FREQUENCY	J7-1 TO J7-2	J7-3 TO J7-4	J7-5 TO J7-6	YCIV
200 HZ	1	1	0	0600 SA/PA, 0630 EA/VA, 0720 SA/PA, 0840 SA/PA, 0830 EA/VA, 0920 SA/PA, 0930 EA/VA, 1000 SA/PA, 1340 SA/PA, 1500 SA/PA
196 HZ	1	1	1	
192 HZ	0	1	0	0700 EA/VA, 0800 EA/VA, 1220 EA/VA, 1380 EA/VA
188 HZ	0	1	1	1180 SA/PA
186 HZ	1	0	0	0770 SA/PA, 0590 EA/VA, 1070 SA/PA
182 HZ	0	0	0	0650 SA/PA, 0760 EA/VA, 1050 EA/VA
178HZ	1	0	1	1120 EA/VA
178 HZ (SPARE)	0	0	1	

## SECTION 7 - OPERATION

### OPERATING CONTROLS

#### Anti-recycle Timer

A typical 5 or 10 minute anti-recycle timer is not necessary to allow compressor motor cooling, due to the VSD's ability to provide a low current inrush start. The system does utilize a fixed 120 second anti-recycle timer to prevent short cycling of systems and to allow positioning the Feed and Drain Valves to a zero (closed) position by the Flash Tank Drain and Feed Valve Controller in the event of a power failure.

On power-up of the control panel, the anti-recycle timer for each system will be set to 120 seconds and must time out before a compressor is allowed to start.

Whenever a system starts, the anti-recycle timer for all systems will be set to 120 seconds and will count down from the time the motor starts. The timer must time out before another compressor is allowed to start.

Whenever a system shuts down, the anti-recycle timer for that system will be set to 120 seconds. The timer must time out before the system is allowed to restart.

#### Evaporator Pump Control

The evaporator pump dry contacts are energized when any of the following conditions are true:

- If a Low Leaving Chilled Liquid Fault occurs.
- Whenever a compressor is running.
- The Daily Schedule is ON and the UNIT switch is ON.

Even if one of above is true, the pump will not run if the panel has been powered up for less than 30 seconds or if the pump has run in the last 30 seconds to prevent pump motor overheating.

#### Evaporator Heater Control

The evaporator heater is controlled by ambient air temperature. If no systems are running and the ambient temperature drops below 40°F, the heater is turned on. If no systems are running and the temperature rises above 45°F the heater is turned off. Whenever a system is running, the evaporator heater is turned off. Both evaporator heater outputs will always be

turned on and off together. An under voltage condition will keep the heater off until full voltage is restored to the system. The heater will protect the evaporator from freeze-up down to -20°F (-29°C).

#### Pumpdown Control

The VSD assures a smooth slow compressor start. As a result of this, neither pumpdown on start-up or pumpdown on shutdown is required. The Drain and Feed Valves will close when a compressor stops. This is a similar to a liquid line solenoid valve closing on a conventional chiller.

#### Compressor Heater Control

Each compressor has its own heater. The purpose of the heater is to assure refrigerant does not condense in the compressor. There is no oil sump, but refrigerant could possibly condense in the rotors or the motor housing. The heater will be off whenever the respective compressor is running. As soon as the compressor shuts off, the heater will turn on as long as all motor temperature sensors in the compressor read less than 158°F. The heater will turn off, if any internal compressor motor temperature sensor reads more than 160°F.

#### Alarms

Each system has its own alarm. The Alarm output is ON (dry contact closed) when no fault condition is present and OFF (dry contact open) to indicate an alarm situation. The Alarm should be activated (contact open), if any of the following are true.

- A System is faulted or inhibited from starting for more than 5 seconds.
- The Unit is faulted or inhibited from starting for more than 5 seconds.
- A System is locked out.
- The Unit is locked out.
- Power is removed from the chiller.

#### Chiller Run Contact

The Chiller Run dry contact is closed whenever any system is running. It is open when all systems are shut off.

## Unit Switch



LD10605

UNIT  
SWITCH

A double pole single throw ON/OFF rocker switch on the front of the control panel is used to turn the entire chiller on and off. When the switch is placed in the OFF position, the entire unit shuts down immediately. One pole of the UNIT switch contacts is wired to the Sys 1/3 and the other to Sys 2/4 VSD Run Signal input and the Chiller Control Board “UNIT switch X” digital input (X equals System 1 or 2). Separate System Fuses are also wired in series with each set of UNIT switch contacts. If either fuse is pulled or blown, only the system with the good fuse (Input is high) will run. When both inputs are high, the entire chiller will be enabled to run. When both inputs are low, the chiller will be disabled as a UNIT switch OFF Shutdown.

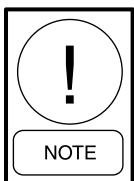

***The UNIT switch should never be used to shut down the chiller except in an emergency. When the switch is thrown, the compressors will immediately shut down. Since the compressors are not permitted to come to a controlled stop, the rotors may back-spin, which may result in some unusual compressor noise. The back-spin will not hurt the compressors, but should be avoided.***

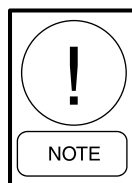

***It is suggested that the System Switches on the keypad be used whenever possible to turn a system off and allow the compressor to complete a controlled shutdown.***

## BASIC OPERATING SEQUENCE

## Start Sequence and Loading

To initiate the start sequence of the chiller, the following conditions must be satisfied before the precharge of the DC Bus will take place:

- UNIT SWITCH must be ON.
- At least one System Switch is ON
- Run permissive inputs (Remote Cycling Contacts) must be closed.
- No unit faults exist.
- No unit start inhibits exist.
- At least one system not faulted or inhibited.
- The Daily Schedule is calling for the chiller to run.
- The Flow Switch is closed.
- Leaving Chilled Liquid Setpoint is above the Setpoint plus CR (Setpoint High Limit).

Once the precharge takes place, if the anti-recycle timer is timed out the chiller control system on the Chiller Control Board will select the number of compressors to start and begin operation of the compressors. The compressor(s) speed will be ramped to the minimum start frequency and increase speed as needed in an effort to regulate the leaving chilled liquid temperature to meet the desired Setpoint.

When a compressor starts, the Feed and Drain Valves on the system will immediately begin to control superheat and the liquid level in the flash tank and the Chiller Control Board microprocessor will begin to regulate the speed on the VSD to bring the chilled liquid temperature to within the Control Range (CR). The microprocessor will regulate the speed of the compressor(s) primarily based on temperature offset as the loading timer permits.

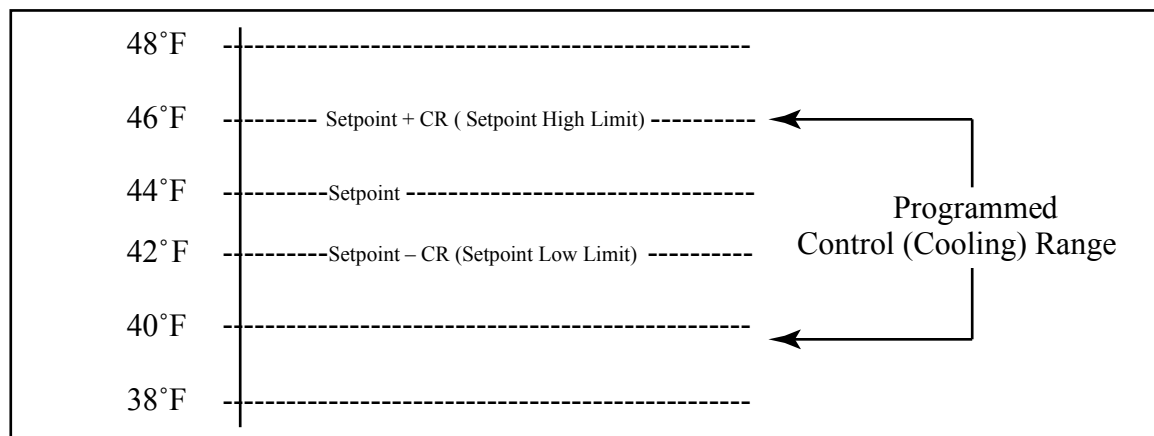

**FIG. 48 - CHILLER CONTROL (COOLING) RANGE**

LD10625

The Setpoint is the Leaving Chilled Liquid Temperature midpoint of the Control (Cooling) Range. The Setpoint High Limit is the Setpoint plus the Control Range. The Setpoint Low Limit is the Setpoint minus the Control Range. The chiller will attempt to control within the temperature range programmed by the Setpoint plus or minus CR.

Starting and stopping of compressors will be handled by the Standard or High IPLV Capacity Control Routine. Loading and unloading will be controlled by temperature offset and rate by the Fuzzy Logic Control Routine.

A graphical representation of the Setpoint and high and low limit (plus or minus CR) are shown in FIG. 48.

## NUMBER OF COMPRESSORS TO START

### General

The number of compressors to start control logic varies between the standard and optional High IPLV chillers. Standard IPLV chiller control utilizes sequential logic that requires the microprocessor to start 1 compressor at a time and only add a compressor when all running compressors reach maximum speed. Optional High IPLV chillers have control algorithms that provide “smart” anticipatory control to determine how many compressors need to be started to satisfy the current load. The “smart” logic is capable of reducing short cycling, and reducing loading time on a hot water start, and starting all compressors at the same time.

### Standard IPLV

The Standard IPLV control always starts a single compressor under all circumstances as the first step of

loading. The Chiller Control Board does not make decisions on the number of compressors to start based on chilled liquid temperatures and prior compressor operation when starting the chiller. An additional compressor is only started when the lead compressor has reached maximum speed and cooling requirements are not satisfied.

### Optional Optimized High IPLV

On optimized IPLV chillers, the Number of Compressors to Start Logic will be used to determine how many compressors should be run when the unit starts from the all compressors stopped state. This routine will try to run all the compressors unless it is determined that less will be needed due to light load.

The first step in the sequence is for the microprocessor to set the number of compressors to start equal to the number of compressors in the chiller. The microprocessor will look at two prior conditions relating to the compressor operating time the previous time it ran and how long the last compressor has been off along with two indicators of chilled liquid load requirements (rate of change of chilled liquid temperature and deviation from setpoint). Temperature deviation is the amount of error compared to the setpoint high limit (Setpoint plus CR). Based on this information, the microprocessor will then determine the number of compressors to start. The flowchart in FIG. 49 describes the compressor starting decision process.

It is desirable to run as many compressors as possible for increased efficiency. Optimized logic will keep as many compressors on line and reduce speed in an effort to optimize the use of the entire evaporator tube surface.

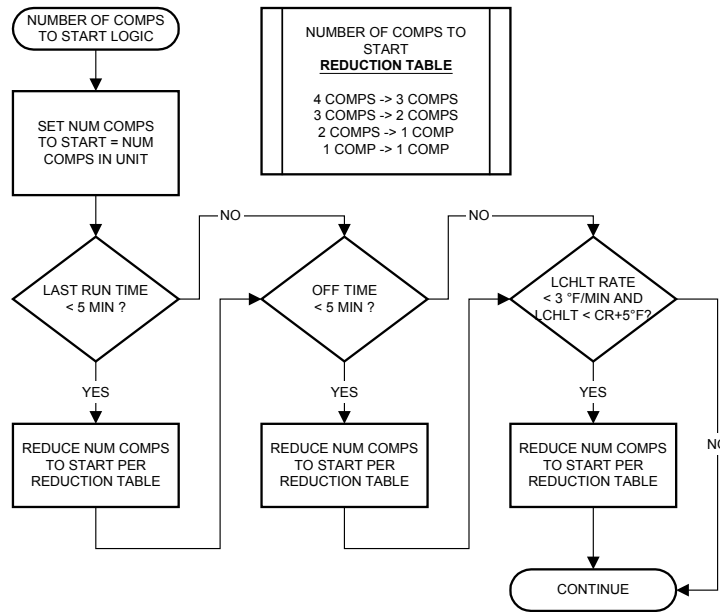

LD10626

FIG. 49 - NUMBER OF COMPRESSORS TO START

**MINIMUM VSD COMPRESSOR START/RUN FREQUENCY**

**Minimum VSD Start Frequency**

The Minimum VSD Compressor Start Frequency is based on ambient temperature and determines the frequency (speed) the compressor(s) is ramped to at start. At higher ambients, higher speeds are needed to provide adequate motor cooling. At low ambients, higher motor speeds are needed to develop oil pressure differential at start. The temperature ranges and the associated start frequency follows the guidelines below:

- If the ambient temperature is 25°F or less, the Minimum VSD Start Frequency will be 70 Hz.
- If the ambient temperature is between 26 and 40 °F (-3 and 4°C), the Minimum VSD Start Frequency is 60 HZ.
- If the ambient temperature is between 41 and 110 °F (5 and 43°C), the Minimum VSD Start Frequency will be 50 Hz.
- If the ambient is between 110 and 125 °F (43 and 52°C), the Minimum VSD Start Frequency is scaled according to the following formula:  
 $(3 \times \text{Ambient Temperature}) - 280^\circ\text{F}$ .

The formula is also represented by the graph in FIG. 50.

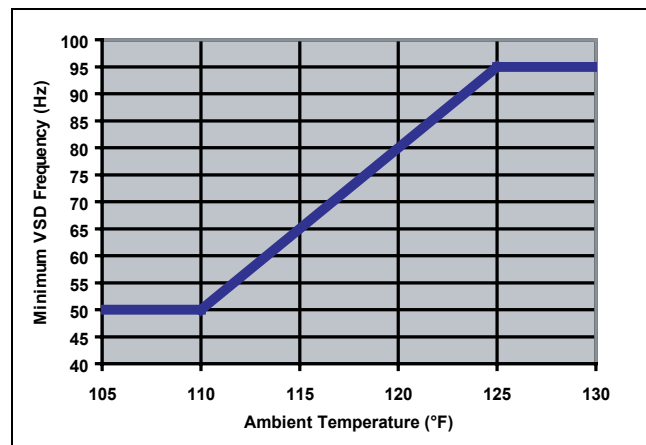

NOTE: The graph above also illustrates the scaled frequency:

LD10627

FIG. 50 - MINIMUM VSD START FREQUENCY

- Above 125°F, the minimum VSD Start Frequency is 95 Hz.

**Minimum VSD Run Frequency**

The Minimum VSD Compressor Run Frequency is based on ambient temperature and determines the minimum frequency (speed) the compressor(s) is permitted to run as the system unloads. At high ambients, higher motor speeds are needed to cool the compressor motor. The temperature ranges and the associated start frequency follows the guidelines below:

- If the ambient temperature is less than 110°F, the Minimum VSD Run Frequency will be 50 Hz.

- If the ambient is between 110 and 125°F (43 and 52°C), the Minimum VSD Run Frequency is scaled according to the following formula:  
(3 x Ambient Temperature) - 280°F.

The formula is also represented by the graph in FIG. 51.

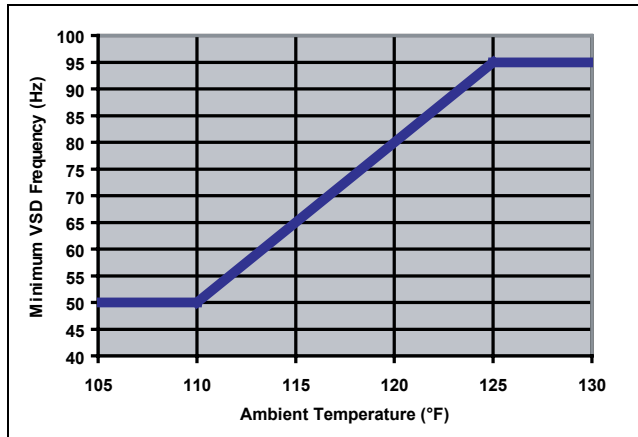

NOTE: The graph above also illustrates the scaled frequency:

LD10628

**FIG. 51 - MINIMUM VSD RUN FREQUENCY**

- If the ambient temperature is more than 125°F, the Minimum VSD Run Frequency will be 95 Hz.

## ACCELERATION/DECELERATION RATE WHEN STARTING/STOPPING COMPRESSORS

### VSD Acceleration and Deceleration Rates

The acceleration rate changes with frequency and follows the guidelines below:

- Between 0 and 50 Hz, the acceleration is 10 Hz/sec.
- Between 50 and 200 Hz, the acceleration is 30.4 Hz/sec. Even though the acceleration rate of 30.4 Hz/sec is possible up to 200 Hz, the frequency (speed) is limited by the minimum start frequency and the add a compressor frequency calculation performed by the microprocessor when bringing on an additional compressor.

When decelerating, the deceleration rate changes with frequency and follows the guidelines below:

- Between 200 and 100 Hz, the deceleration time is 30.4 Hz/sec.
- Between 100 and 0 Hz, the deceleration time is 10 Hz/sec.

When a compressor stops, back-spin of the compressor will often occur as the pressure differential between discharge and suction equalizes. This should not be a cause of concern.

## STANDARD IPLV CAPACITY CONTROL

(Loading/Unloading and starting additional compressors)

Standard IPLV Capacity Control is installed in the chiller at the factory using a dedicated EPROM (software), part # 031-02476-001, for “Standard Only” IPLV control. If the LCHLT is more than the programmed Setpoint plus CR, only a single compressor is permitted to start under Standard IPLV control. The compressor will start at the minimum start frequency based on ambient temperature (Page 214). The lead compressor Feed and Drain Valves will immediately begin to control superheat and liquid level in the flash tank.

When a compressor starts, the load and unload timers will be set to 30 seconds. During the first 30 seconds of operation after a compressor reaches the start frequency, loading/unloading is inhibited.

After 30 seconds, the control logic looks at the LCHLT temp, compares it to the Setpoint plus CR, and makes decisions to load or unload.

For precise capacity control, the Chiller Control Board microprocessor loads and unloads compressors quickly, as fast as every 2 seconds, in increments of 0.1 to 1 Hz each time a load or unload change is required. Fixed load and unload timers of 2 sec. are set, after a speed change of 0.11 to 1 Hz, to minimize undershoot and overshoot.

As additional cooling is required (LCHLT more than Setpoint plus CR), the Chiller Control Board microprocessor will increase the speed of the compressor at the rate of 0.1 to 1 Hz every 2 seconds until the load is satisfied. Loading will continue to occur as long as leaving chilled liquid temperature is above the Setpoint plus CR.

If the temperature falls very near or within the Control Range, the Chiller Control Board microprocessor will make decisions regarding speed changes under conditions where the “error” and “rate” conflict. Under these conditions, loading/unloading follows the guidelines described in the “Fuzzy Logic Control” section (Page 216).

If the compressor speed exceeds the maximum frequency the compressor is allowed to operate minus 1 hertz for a period of 3 minutes without bringing the leaving chilled liquid temperature to within Setpoint plus CR/2, the chiller control will make a decision to start another compressor. At this point, the first compressor will decelerate to a frequency of 5 Hz. Reducing the frequency of the running compressor to 5 Hz enables the differential between discharge and suction pressure to be reduced to a point where it will not affect motor current when the running compressor is ramped up. It also reduces the possibility of backspin on the running compressor. The next lag compressor will be activated and all compressors will be accelerated to the START FREQ. The START FREQ is specified by the formula:

$\text{START FREQ} = \frac{\text{Current VSD Freq} \times (\text{Number of Compressor enabled} - 1)}{\text{Number of Compressors enabled}}$ <p>For example: Current VSD Freq = max freq of the chiller = 200 Hz.                  Number of compressors enabled = 2 = Original compressor running, plus the compressor to be added.</p>
---

In this example, assume a single compressor had been running at the max frequency of 200 Hz without satisfying cooling demand. (2) compressors are now enabled when the second compressor is activated. Placing these values in the formula, the START Frequency equals  $200 \text{ Hz} \times (2-1)/2$  equals 100 Hz. The compressors will be accelerated to a start frequency of 100 Hz. Load and unload timers will be set to 30 seconds. The anti-recycle timer will be set to 120 seconds.

If additional cooling is required, after the initial 30 seconds of operation, loading will occur at the rate of 0.1 -1 Hz every 2 seconds, unless load limiting occurs.

If the cooling capacity exceeds the demand and temperature continues to drop while in the Control Range (CR) with multiple compressors operating, the Chiller Control Board microprocessor will decrease the speed of the compressor(s) at the rate of 0.1 to 1 Hz every 2 seconds until the LCHLT stabilizes within the Control Range. If frequency (speed) drops below the LESS COMP FREQ – 20 Hz or the minimum VSD frequency, whichever is higher, the compressors will be decelerated to a speed of 5 Hz, the last compressor disabled, and the remaining compressor(s) restarted minus one lag compressor. The LESS COMP FREQ is designated as:

$\text{LESS COMP FREQ} = \frac{\text{Max VSD Freq} \times (\text{Number of compressor enabled} - 1)}{\text{Number of Compressors enabled}}$ <p>For example: 200 Hz = max freq of the chiller.                  Number of compressors enabled before shutdown = 2</p>
--

In this example, one compressor will be shut down when the speed of the compressors drops to  $200 \text{ Hz} \times (2-1)/2 = 100 \text{ Hz} - 20 \text{ Hz} = 80 \text{ Hz}$ .

The restart frequency for the compressor(s) after removing a lag compressor is the OFF FREQ. The OFF FREQ is designated as:

$\text{OFF FREQ} = \frac{\text{Current VSD Freq} \times (\text{Number of compressors enabled} + 1)}{\text{Number of Compressors enabled}}$ <p>For example: 80 Hz = current freq of the chiller in the example above.                  Number of compressors enabled at shutdown = 1</p>
---

In the example above, one compressor will restart at 160 Hz as calculated in the formula below:

$$\frac{80 \text{ Hz} \times (1+1)}{1} = 160 \text{ Hz}$$

The load timer will also be set to 30 seconds and the unload timer will be set to 10 seconds.

On 3 and 4 compressor chillers, if frequency (speed) drops below the LESS COMP FREQ – 20 Hz or the minimum VSD frequency, whichever is higher, another lag compressor will be shut down using the same guidelines.

When the system is only operating a single (lead) compressor, if temperature continues to stay below the Control Range (Setpoint – CR) or continues to drop while in the Control Range, the Chiller Control Board microprocessor will unload the compressor at the rate of 0.1 to 1 Hz every 2 seconds. This will continue until the frequency drops below the Minimum VSD Frequency determined by the ambient temperature. At this point, the lead compressor will be shut down, if temperature is below the Setpoint - CR.

**Fuzzy Logic Control**

The fuzzy logic control in software makes decisions to increase or decrease speed according to the error or deviation from Setpoint, and the rate of change of chilled liquid temperature. Before making a change in speed, the Chiller Control Board microprocessor will look at the load and unload timers to assure they are timed out. It also looks to assure there is no load limiting in effect. Each time a change is made, the incremental change in speed is still between 0.1 and 1 Hz, unless temperatures fall near the leaving chilled liquid cutout.

In most situations, when the chilled liquid temperature is above the Setpoint plus CR, the Chiller Control Board microprocessor will continue to increase

the speed of the compressor(s) to load the chiller until temperature drops in the general range of the Setpoint High Limit (Setpoint plus CR). If the rate of change is dropping too fast and there is potential for overshoot, the Chiller Control Board microprocessor may elect not to continue to increase speed.

In cases where temperature is dropping too fast when temperature is within the desired Control Range, the microprocessor will be required to make decisions regarding speed changes under conditions where the “error” and “rate” conflict. For example, the microprocessor may elect to decrease the speed of the compressor(s) if the error is “0” (temperature is at Setpoint), while the rate of change of chilled liquid temperature is falling (negative). The Chiller Control Board microprocessor may also elect to hold the speed when error is “positive” (temperature is above Setpoint, but not above Setpoint plus CR) because the rate of change of chilled liquid is “negative” (falling). TABLE 4 illustrates these conditions.

**TABLE 4 - FUZZY LOGIC LOADING/UNLOADING VS. ERROR**

	<b>NEGATIVE ERROR</b>	<b>ZERO ERROR</b>	<b>POSITIVE ERROR</b>
<b>NEGATIVE RATE</b>	UNLOAD	UNLOAD	HOLD
<b>ZERO RATE</b>	UNLOAD	HOLD	HOLD
<b>POSITIVE RATE</b>	HOLD	LOAD	LOAD

To avoid overshoot or nuisance trips on the low chilled liquid cutout, when the temperature is below the Setpoint – CR/2, the Chiller Control Board microprocessor will reduce the speed of the compressor(s) to unload the chiller by 2.0 Hz every 2 seconds. If temperature drops to within 1.0°F above the Low Chilled Liquid temp Cutout, the Chiller Control Board microprocessor will unload the compressors at the rate of 4.0 Hz every 2 seconds.

As the temperature rises the microprocessor’s fuzzy logic will factor in the rate of change before continuing to unload. If the rate of change is rising too fast and there is potential for a positive overshoot, the Chiller Control Board microprocessor may elect not to continue to decrease speed.

In cases where temperature is rising too fast, when temperature is within the desired Control Range, the Chiller Control Board microprocessor will be required to make decisions regarding speed changes under conditions where the “error” and “rate” conflict. For example, the Chiller Control Board microprocessor may elect to increase the speed of the compressor(s) if the error is “0” (temperature is at Setpoint), while the rate of change of chilled liquid temperature is “positive” (rising). The Chiller Control Board microprocessor may also elect to hold capacity when error is “negative” (temperature is below Setpoint) because the rate of change of chilled liquid is “positive” (rising). TABLE 4 illustrates these conditions and the loading response from the Chiller Control Board microprocessor.

### Hot Water Starts

On a hot water start under "best" case conditions, assuming power has not been removed and the 120 second timer does not inhibit starting, the design of the control algorithm for a 2compressor Standard IPLV leaving chilled liquid capacity control allows full loading of a chiller in slightly more than 14-1/2 minutes, regardless of the number of compressors. This time period assumes load limiting does not affect the loading sequence and the ambient is above 40°F.

### Lag Compressor Operation in Load Limiting

When a single compressor is operating in current, discharge pressure, suction pressure, VSD internal ambient, or VSD baseplate temperature limiting for more than 5 minutes and chilled liquid temperature is more than Setpoint plus CR, the Chiller Control Board microprocessor will turn on the lag compressor to bring the chilled liquid temperature within the Control Range. After 1 hour the Chiller Control Board microprocessor will shut down the lag compressor and attempt to control temperature with only the lead compressor to satisfy the load.

### OPTIONAL HIGH IPLV CAPACITY CONTROL

(Loading/Unloading and starting additional compressors)

Optional High IPLV Capacity Control is installed in the chiller at the factory using a dedicated EPROM (software), part # 031-02476-002, for High IPLV control. Its purpose is to control compressors as effectively as possible, optimizing control of both the compressors and condenser fans. If the LWT is more than the programmed Setpoint plus CR, the Chiller Control Board microprocessor will follow the flow chart (Page 214) to determine the number of compressors to start based on the last run time, time off, and the rate of change

of chilled liquid temperature. The compressor(s) will start at the minimum start frequency based on ambient temperature (Page 214). The respective system Feed and Drain Valves will immediately begin to control superheat and liquid level in the flash tank.

When compressors start, the load and unload timers will be set to 30 seconds. During the first 30 seconds of operation after a compressor reaches the start frequency, loading/unloading is inhibited. After 30 seconds, the control logic looks at the LWT temp, compares it to the Setpoint plus CR, and makes a decision to load or unload.

For precise capacity control, the Chiller Control Board microprocessor loads and unloads compressors quickly, as fast as every 2 seconds, in increments of 0.1 to 1 Hz each time a load or unload change is required. Fixed load and unload timers of 2 sec. are set, after a speed change of 0.1 to 1 Hz, to minimize undershoot and overshoot.

As additional cooling is required (LCHLT more than Setpoint plus CR), the Chiller Control Board microprocessor will increase the speed of the compressor at the rate of 1Hz every 2 seconds until the load is satisfied. Loading will continue to occur as long as leaving chilled liquid temperature is above the Setpoint plus CR.

The chiller control board will be make decisions regarding speed changes under conditions where the “error” and “rate” conflict. Under these conditions, loading/unloading follows the guidelines described in the “Fuzzy Logic Control” section (Page 219).

If chilled liquid temperature is not satisfied and above Setpoint plus CR, the microprocessor looks to see if any of the lag compressors are not running. If any lag compressor(s) is off, the Chiller Control Board microprocessor looks at the VSD output frequency. If the VSD output frequency is greater than the ADD COMPRESSOR FREQUENCY plus 15 Hz or equal to the maximum chiller speed (frequency), the microprocessor starts an additional compressor. The ADD COMPRESSOR FREQUENCY is calculated as:

ADD COMPRESSOR FREQUENCY	=	Minimum Start Freq x (Number of Compressors Running +1)
		Number of Compressors Running

Example - A single compressor had been running without satisfying cooling demands. Assume the minimum VSD start frequency based on ambient is 50 Hz for this

example. The number of compressors running in the formula will equal to 1. Placing the values into the formula:  $50 \text{ Hz} \times (1+1)/1 = 100 \text{ Hz}$ . The add compressor frequency will equal 100 Hz. Since the controls are designed to add a compressor at a frequency 15 Hz above this point, a compressor will be added if the speed reaches 115 Hz.

When a compressor is to be added, the Chiller Control Board microprocessor decelerates the compressor VSD frequency to 5 Hertz. This enables the differential between discharge and suction pressure to be reduced to a point where it will not affect motor current when the compressor is restarted. It also reduces the chance for backspin on the running compressor. The next lag compressor is activated and all compressors are accelerated to the START FREQUENCY. The START FREQUENCY is calculated as:

START FREQUENCY	=	Current VSD Freq x (Number of Compressors Running -1)
		Number of Compressors Running

With 2 compressors now running and a current VSD frequency of 115 HZ, the start frequency will be computed as:

$$\frac{115 \text{ Hz} \times (2-1)}{2} = \frac{115}{2} = 58 \text{ Hz}$$

When the compressors restart, loading and unloading is inhibited for 30 seconds after the compressor(s) reaches the start frequency, as is the case on any compressor start. The anti-recycle timer will be set to 120 sec.

In a situation where a single compressor on a 2 compressor chiller is running and is in load limiting for any reason, and LCHLT more than Setpoint plus CR for less than 5 minutes, but more than 30 seconds, the microprocessor will reset the load/unload timers to 2 seconds every “potential” load cycle. When LCHLT more than Setpoint plus CR for more than 5 minutes, the microprocessor will enable the lag compressor just as it were not satisfied and determine a second compressor was required to handle the load, since the lead compressor is load limited.

If the cooling capacity exceeds the demand (LCHLT less than Setpoint – CR/2) and multiple compressors are operating, the Chiller Control Board microprocessor will decrease the speed of the compressors at the rate of 0.1 to 1 Hz every 2 seconds until the LCHLT rises to within the Control Range. If temp remains below Setpoint – CR/2, rate is falling, and speed falls to the minimum VSD frequency as determined by the ambient, the VSD will decelerate all compressors to 5

Hertz. The last lag compressor will be shut down. The remaining compressors will be restarted minus the lag compressor. The lead compressor will restart and accelerate to the STOP COMP FREQ designated as:

STOP COMP FREQ	=	Minimum VSD Freq x (Number of Compressors Running +1) Number of Compressors Running
In this example: Number of compressors running = 1		
Minimum VSD Freq.= 50 Hz		

In the example above, one compressor will restart at 100 Hz as indicated in the formula below:

$$\frac{50 \text{ Hz} \times (1+1)}{1} = 100 \text{ Hz}$$

The load timer will also be set to 30 seconds and the unload timer will be set to 10 seconds.

On 3 and 4 compressor chillers, if temperature stays below the Setpoint minus the Control Range/2, another lag compressor will be shut down using the same guidelines.

When the system is only operating a single (lead) compressor, if temperature continues to stay below the Control Range (Setpoint minus CR), the Chiller Control Board microprocessor will unload the compressor at the rate of 1Hz every 2 seconds. This will continue until the frequency drops below the Minimum VSD Frequency determined by the ambient temperature. At this point, the lead compressor will be shut down.

### Fuzzy Logic Control

The fuzzy logic control in software makes decisions to load or unload according to the error or deviation from Setpoint, and the rate of change of chilled liquid temperature. Before making a change in speed, the logic will look at the load and unload timers to assure they are timed out. It also looks to assure there is no load limiting in effect. Each time a change is made, the incremental change in speed is still 0.1 to 1 Hz, unless temperatures fall near the leaving chilled liquid cutout.

In most situations, when the chilled liquid temperature is above the Setpoint plus CR, the Chiller Control Board microprocessor will continue to increase the speed of the compressor(s) to load the chiller until temperature drops in the general range of the Setpoint High Limit. As the temperature drops and approaches the Setpoint High Limit (Setpoint plus CR), the microprocessor’s fuzzy logic will begin factoring in the rate of change before continuing to load. If the rate of change is dropping too fast and there

is potential for overshoot, the Chiller Control Board microprocessor may elect not to continue to increase speed.

In cases where temperature is dropping too fast, when temperature is within the desired Control Range, the Chiller Control Board microprocessor will be required to make decisions regarding speed changes under conditions where the “error” and “rate” conflict. For example, the Chiller Control Board microprocessor may elect to reduce the speed of the compressor(s) if the error is “0” (temperature is at Setpoint); while the rate of change of chilled liquid temperature is “negative”(falling). The Chiller Control Board microprocessor may also elect to hold capacity when error is “positive” (temperature is above Setpoint, but not above Setpoint plus CR) because the rate of change of chilled liquid is “negative” (falling). TABLE 5 illustrates these conditions.

**TABLE 5 - FUZZY LOGIC LOADING/UNLOADING VS. ERROR**

	NEGATIVE ERROR	ZERO ERROR	POSITIVE ERROR
NEGATIVE RATE	UNLOAD	UNLOAD	HOLD
ZERO RATE	UNLOAD	HOLD	HOLD
POSITIVE RATE	HOLD	LOAD	LOAD

When temperature is significantly below the Setpoint minus CR/2, the Chiller Control Board microprocessor will reduce the speed of the compressor(s) to unload the chiller by 2.0 Hz every 2 seconds. If temperature drops to within 1.0°F above the Low Chilled Liquid Temperature Cutout, the Chiller Control Board microprocessor will unload at the rate of 4.0 Hz every 2 seconds.

As the temperature rises toward Setpoint minus CR, the Chiller Control Board microprocessor’s fuzzy logic will begin factoring in the rate of change before continuing to unload. If the rate of change is rising too fast and there is potential for overshoot, the Chiller Control Board microprocessor may elect not to decrease speed.

In cases where temperature is rising too fast, when temperature is within the desired Control Range, the Chiller Control Board microprocessor will be required to make decisions regarding speed changes under conditions where the “error” and “rate” conflict. For example, the

Chiller Control Board microprocessor may elect to increase the speed of the compressor(s) if the error is “0” (temperature is at Setpoint), while the rate of change of chilled liquid temperature is “positive” (rising). The Chiller Control Board microprocessor may also elect to hold capacity when error is “negative” (temperature is below Setpoint) because the rate of change of chilled liquid is “positive” (rising). TABLE 5 illustrates these conditions and the response from the Chiller Control Board microprocessor.

**Hot Water Starts**

On a hot water start under “best” case conditions, assuming power has not been removed and the 120 sec timer does not inhibit starting, the design of the control algorithm for a 2 compressor High IPLV leaving chilled liquid capacity control allows full loading of a chiller in slightly more than 6 minutes, regardless of the number of compressors, if all the compressors start at the same time. This time period assumes load limiting does not affect the loading sequence and the ambient is above 40°F.

**LOAD LIMITING CONTROL**

**Load Limiting**

The Load Limiting Controls are intended to prevent a system from reaching a safety trip level. Load limiting controls prevent loading or unload compressors to prevent tripping on a safety. Limiting controls operate for Motor Current %FLA, Suction Pressure, Discharge Pressure, VSD Baseplate Temperature, and VSD Internal Ambient Temperature.

All running system’s load limit control values are checked every 2 seconds. Load limiting prevents a system from loading (no increase even though cooling demand requires loading) when the specific operating parameter is within a specific range of values. If the value is above the range where loading is inhibited, the logic will unload the chiller based on the amount (%) the limit has been exceeded. Load limiting affects all compressors, even though only one system may be affected.

If more than one operating parameter is exceeding the value where unloading is required, the value with the highest amount of unloading will determine the unloading. All load limiting controls are active at start-up except suction pressure limiting.

**Motor Current Load Limiting/Unloading**

Motor current load limiting helps prevent the system from tripping on the motor overload safety. The motor “Current Limit Setpoint” is based on %FLA motor current and is programmable under the PROGRAM key or may be set by a remote device. Motor current load limiting prevents the system from loading even though increased loading may be required when the current is between the “Current Limit Setpoint minus 2%” and the “Current Limit setpoint”. Between the “Current Limit Setpoint” and the “Current Limit Setpoint plus 5%”, the system will unload every 2 seconds according to the amount current is exceeding the “Current Limit Setpoint”. At the “Current limit Setpoint”, 0 Hz reduction in speed will take place and at the “Current Limit Setpoint plus 5%”, a 10 Hz speed reduction will take place. Between the “Current Limit Setpoint” and “Current Limit Setpoint plus 5%”, unloading will occur according to the TABLE 6.

**TABLE 6 - CURRENT LIMIT LOAD LIMITING/UNLOADING**

CURRENT LIMIT SETPOINT	UNLOADING
Current Limit Setpoint -2% to +0%	0 Hz
Current Limit Setpoint +1%	2 Hz
Current Limit Setpoint +2%	4 Hz
Current Limit Setpoint +3%	6 Hz
Current Limit Setpoint +4%	8 Hz
Current Limit Setpoint +5%	10 Hz

**Discharge Pressure Load Limiting/Unloading**

Discharge pressure load limiting protects the condenser from experiencing dangerously high pressures. A system is permitted to load normally as long as the discharge pressure is below the High Discharge Pressure Cutout minus 20 PSIG. Between Cutout minus 20PSIG and Cutout minus 15 PSIG loading is inhibited even though increased loading may be required. Between Cutout minus 15 PSIG and the Discharge Pressure Cutout, forced unloading is performed every 2 seconds according to TABLE 7. The discharge pressure unload point is fixed at 255 PSIG.

**TABLE 7 - DISCHARGE PRESSURE  
LOAD LIMITING/UNLOADING**

DISCHARGE PRESSURE	UN-LOADING
Discharge Pressure Cutout- 20 PSIG & Discharge Pressure Cutout- 15 PSIG	0 Hz
Discharge Pressure Cutout- 13.5 PSIG	1 Hz
Discharge Pressure Cutout- 12 PSIG	2 Hz
Discharge Pressure Cutout- 10.5 PSIG	3 Hz
Discharge Pressure Cutout- 9 PSIG	4 Hz
Discharge Pressure Cutout- 7.5 PSIG	5 Hz
Discharge Pressure Cutout- 6 PSIG	6 Hz
Discharge Pressure Cutout- 4.5 PSIG	7 Hz
Discharge Pressure Cutout- 3 PSIG	8 Hz
Discharge Pressure Cutout- 1.5 PSIG	9 Hz
Discharge Pressure Cutout- 0 PSIG	10 Hz

**Suction Pressure Load Limiting/Unloading**

Suction pressure load limiting helps to protect the evaporator from freezing. A system is permitted to load normally as long as the Suction Pressure is above the Suction Pressure Cutout plus 2 PSIG. Between Cutout plus 2 PSIG and the Cutout, loading is inhibited, even though increased loading is required. Between the Suction pressure Cutout and Suction Pressure Cutout minus 10 PSIG, forced unloading is performed every 2 seconds according to TABLE 8 below. This situation would occur if the suction pressure cutout transient override control is in effect (*See "Low Suction Pressure Cutout", Page 247*). The suction pressure cutout is programmed under the PROGRAM key. The default Suction Pressure Cutout is set at 24.0 PSIG.

**TABLE 8 - SUCTION PRESSURE  
LOAD LIMITING/UNLOADING**

SUCTION PRESSURE	UN-LOADING
Suction Pressure is between Cutout +2 PSIG & Suction Pressure Cutout	0 Hz
Suction Pressure Cutout- 1 PSIG	1 Hz
Suction Pressure Cutout- 2 PSIG	2 Hz
Suction Pressure Cutout- 3 PSIG	3 Hz
Suction Pressure Cutout- 4 PSIG	4 Hz
Suction Pressure Cutout- 5 PSIG	5 Hz
Suction Pressure Cutout- 6 PSIG	6 Hz
Suction Pressure Cutout- 7 PSIG	7 Hz
Suction Pressure Cutout- 8 PSIG	8 Hz
Suction Pressure Cutout- 9 PSIG	9 Hz
Suction Pressure Cutout- 10 PSIG	10 Hz

Suction pressure load limiting is active at start-up, to only prevent loading of the compressors. Suction pressure limit unloading will not occur until the system run time reaches 5 minutes of operation to allow the system to stabilize.

**VSD Internal Ambient Temperature Load Limiting**

VSD Internal Ambient temperature limiting helps prevent the unit from tripping on the high internal cabinet temperature safety. A system is permitted to load normally as long as the VSD Internal Ambient is below the VSD Internal Ambient Cutout minus 3°F. Between VSD Internal Ambient Cutout minus 3°F and the VSD Internal Ambient Cutout minus 2°F, loading is inhibited, even though increased loading is required. Between the VSD Internal Ambient Cutout minus 2°F and the VSD Internal Ambient Cutout, forced unloading is performed every 2 seconds according to TABLE 9 below. The VSD Internal Ambient Safety Cutout is 158°F.

**TABLE 9 - VSD INTERNAL AMBIENT  
LOAD LIMITING/UNLOADING**

VSD INTERNAL AMBIENT TEMPERATURE	UN-LOADING
Internal Ambient Temp. is between Cutout- 3°F & Internal Ambient Cutout- 2°F	0 Hz
Internal Ambient Cutout- 1.8°F	1 Hz
Internal Ambient Cutout- 1.6°F	2 Hz
Internal Ambient Cutout- 1.4°F	3 Hz
Internal Ambient Cutout- 1.2°F	4 Hz
Internal Ambient Cutout- 0°F	5 Hz
Internal Ambient Cutout- 0.8°F	6 Hz
Internal Ambient Cutout- 0.6°F	7 Hz
Internal Ambient Cutout- 0.4°F	8 Hz
Internal Ambient Cutout- 0.2°F	9 Hz
Internal Ambient Cutout	10 Hz

**VSD Baseplate Temperature Load Limiting**

VSD Baseplate load limiting helps protect the unit from tripping on the high VSD Baseplate Temp Safety. A system is permitted to load normally as long as the VSD Baseplate temperature is below the VSD Baseplate Temperature Cutout minus 8°F. Between the VSD Baseplate Temperature Cutout minus 8°F and the VSD Baseplate Temperature Cutout minus 4°F, loading is inhibited, even though increased loading is required.

Between the VSD Baseplate Temperature Cutout minus 4°F and the cutout, forced unloading is performed every 2 seconds according to TABLE 10.

**TABLE 10 - VSD BASEPLATE TEMPERATURE LOAD LIMITING/UNLOADING**

VSD BASEPLATE TEMPERATURE	UN-LOADING
Baseplate Temp. is between Cutout- 8°F & Cutout- 4°F	0 Hz
Baseplate Temp. Cutout- 3.6°F	1 Hz
Baseplate Temp. Cutout- 3.2°F	2 Hz
Baseplate Temp. Cutout- 2.8°F	3 Hz
Baseplate Temp. Cutout- 2.4°F	4 Hz
Baseplate Temp. Cutout- 2.0°F	5 Hz
Baseplate Temp. Cutout- 1.6°F	6 Hz
Baseplate Temp. Cutout- 1.2°F	7 Hz
Baseplate Temp. Cutout- 0.8°F	8 Hz
Baseplate Temp. Cutout- 0.4°F	9 Hz
Baseplate Temp. Cutout	10 Hz

**FLASH TANK DRAIN AND FEED VALVE CONTROLLER**

**Valve Controller and Control Algorithm Operation**

The Flash Tank Feed and Drain Valve PI Controller(s) plays a dual role of supplying drive signals to control the opening and closing of both the Flash Tank Feed and Drain Valves. These valves control the liquid level in the flash tank and the suction superheat of the compressor. The Flash Tank Feed and Drain Valve Controller receive analog signals from the Chiller Control Board to position the Feed and Drain Valves.

The Chiller Control Board PI (Proportional plus Integral) control algorithm in the Chiller Control Board software determines the open % for the Drain and Feed valves. A D/A converter on the Chiller Control Board converts the 0-110.0% signal to an output voltage between 0VDC and 10.28VDC and sends it to the Drain and Feed Controller. This voltage is then converted to a valve position by the Drain and Feed Valve Controller and a 2 phase (4 wire), signal drives the Feed Valve open or closed. Power for the Valve Controller comes from a 30VDC supply from the Chiller Control Board.

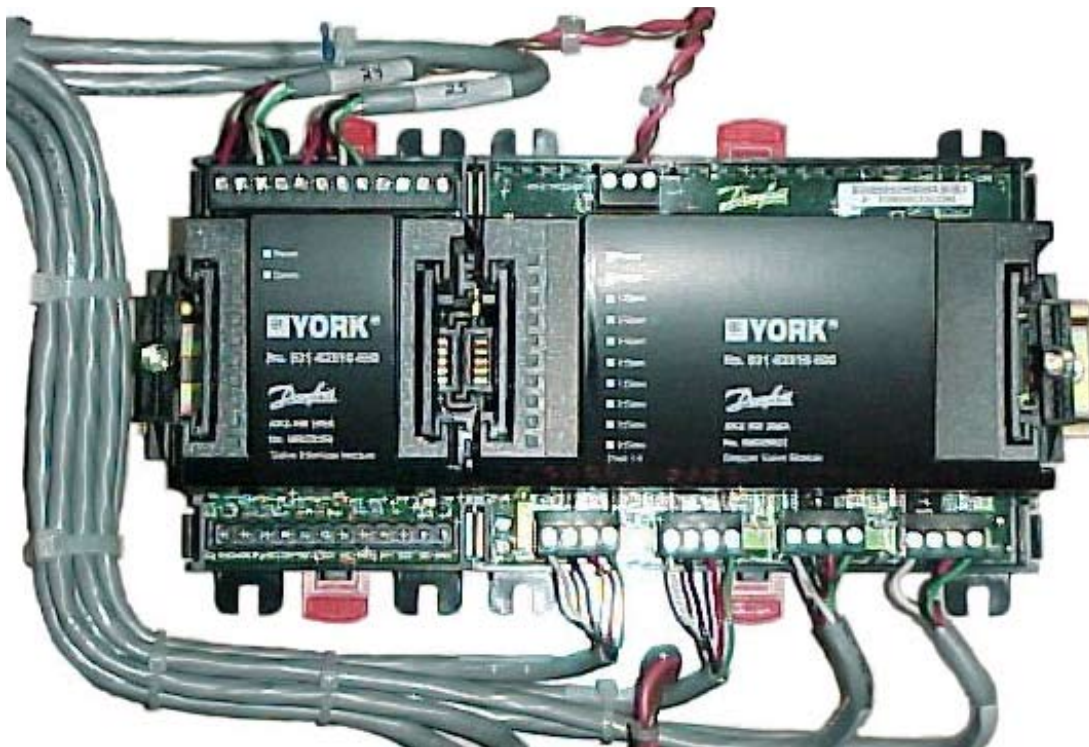

LD10619

**FIG. 52 - FLASH TANK DRAIN AND FEED VALVE CONTROLLER**

The Feed Valve is a stepper motor valve that controls the liquid flow from the condenser to assure the liquid level in the flash tank is maintained at a proper level. The Level Sensor is a rod inserted into the reservoir connected to the side of the flash tank. The sensing rod has an active range of about 12”.

The control algorithm looks at feedback from the Level Sensor and compares it to the fixed level setpoint in the control algorithm. This control strategy attempts to keep the level in the flash tank to approx 35% of the usable portion of the sensing rod. In reality, this is approximately a 50% level in the flash tank. As the level in the flash tank fluctuates, the control algorithm varies the voltage to the Controller, which in turn sends a 2 phase stepped drive signal to open or close the Feed Valve as needed.

As the flash tank level varies farther from the setpoint, the gain of the control algorithm increases for faster response. In some cases, the Feed Valve will fully open or fully close if the levels become too low or too high. When properly charged, the condenser subcooling will be approx. 5-7°F at design conditions as the Feed Valve controls refrigerant flow into the flash tank.

The Drain Valve is also a stepper motor valve. Like the Feed Valve, the controller receives a 0 to 10.28VDC signal from the Chiller Control Board. The controller then converts the signal to a valve position and a 2 phase signal drives the Drain valve open or closed.

The Drain Valve, Controller, and Chiller Control Board Algorithm combination functions as an Electronic Expansion Valve (EEV). The controller receives an analog 0 to 10.28VDC signal sent from the Chiller Control Board, which is based on system suction pressure and suction temperature. These operating parameters are used to compute and control suction superheat according to the Setpoint programmed into the panel under the PROGRAM key. After computing the superheat, the signal to the controller is adjusted and the controller subsequently positions the Drain Valve to control the superheat. The gain of the control algorithm is adjusted to aid in correcting for superheat error.

The Chiller Control Board Algorithm assures the level in the flash tank does not become too high. The level setpoint for control is 35%. Levels normally run 30 to 40% with the economizer solenoid energized (open). With the solenoid closed, levels may vary significantly from the 30 to 40% level. If the level exceeds 85% of the full level, the system will shut down on a fault.

The Feed and Drain Valves in a system open and begin to control as soon as a compressor starts. When the compressor shuts down, the valves are driven to their closed position.

### **MOP Setpoint Control for Hot Water Starts**

Maximum Operating Pressure control overrides superheat control of the Drain Valve when the MOP Setpoint is exceeded on hot water starts. The fixed setpoint is 68°F Saturated Suction Temp (SST). When this value is exceeded, the Drain Valve switches superheat control to suction pressure control equal to 68°F SST.

### **Moderate To High Ambient MOP Setpoint Control.**

In moderate to high ambients, the suction line may be warmed by the ambient, contributing to inaccurate suction superheat measurement at start-up. To avoid this situation, the MOP control utilizes suction pressure control at start-up, which overrides superheat control. For the first minute of run time, the MOP Setpoint is set to:

$$\frac{\text{RCHLT - Superheat Setpoint} - 1.0^{\circ}\text{F}}{\text{Run Time in Seconds}}$$

After the first minute of operation, the MOP Setpoint is ramped from the current calculated value to 68°F over the next minute. At this point, normal superheat control based on the programmed setpoint resumes.

### **Low Ambient MOP Setpoint Control**

In low ambient start-ups, suction pressure is erratic and pressure differentials across the compressor may be low, resulting in low oil differential faults. The Low Ambient MOP setpoint control assures adequate differential is developed between discharge and suction to push oil through the oil cooling system and the compressor.

For the first 5 minutes of system run time, the MOP Setpoint is set to the saturated suction temperature equal to 15PSIG below discharge pressure, which overrides superheat control. The control algorithm will not allow suction pressure control below the cutout. The low limit of the suction pressure is the low suction pressure cutout. After 5 minutes of system run time, the MOP Setpoint is set at 68°F and superheat control based on the programmed setpoint resumes.

### **Actual MOP Setpoint**

The actual MOP Setpoint used by the controller is the minimum of three calculations; the fixed MOP Setpoint, the moderate to high ambient setpoint, and the low ambient setpoint.

**Valve Controller LED's**

The Drain and Feed Valve stepper motor controller is equipped with a pair of LED's on the left side of the module and 10 LED's in the center of the module (FIG. 53). These LED's may be useful during troubleshooting.

A pair of LED's on the left side of the module (FIG. 54) indicate when the module is powered. The Power LED should be lit at all times.



**FIG. 53 - LED LOCATIONS**

LD10629



**FIG. 54 - POWER AND COMMS LED'S**

LD10630

A column of 10 LED's runs from top to bottom on the right side module (FIG. 55).

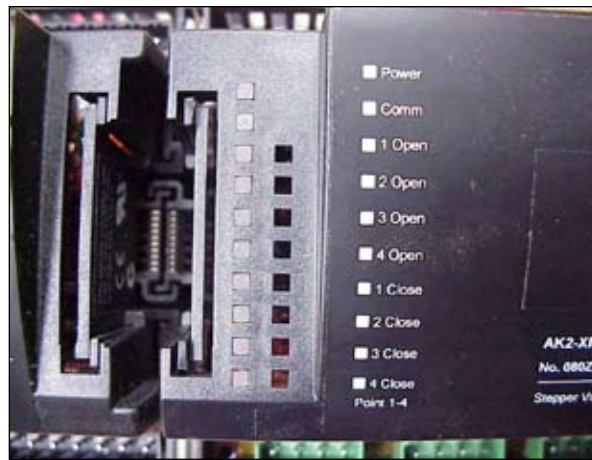

**FIG. 55 - POWER, COMMS AND SYSTEM OPEN/ CLOSE LED'S**

LD10631

A pair of LED's on the top of the module (FIG. 55) indicates when the module is powered and when the module is communicating with the Chiller Control Board. The Power LED should be lit at all times.

The Open and Close LED's on each system indicate when the Feed and Drain valves are being driven open or closed in an effort to control flash tank level and suction superheat. These valves will light "momentarily" when the valves are being pulsed. In most cases other than start-up, they may appear to not light at all. The valves that are controlled by the outputs associated with the LED's are decoded as shown below:

- 1 Open = System #1 or 3 Feed Valve Open
- 2 Open = System #1 or 3 Drain Valve Open
- 3 Open = System #2 or 4 Feed Valve Open
- 4 Open = System #2 or 4 Drain Valve Open
- 5 Close = System #1 or 3 Feed Valve Close
- 6 Close = System #1 or 3 Drain Valve Close
- 7 Close = System #2 or 4 Feed Valve Close
- 8 Close = System #2 or 4 Drain Valve Close

On 3 and 4 compressor chillers, a second module will control systems #3 and #4.

Due to the short duration of the open and close step-pulses, LED lighting will be difficult to observe. In rare cases where validation of the controller output and valve movement needs to be checked, the valves can be operated in Service Mode. When operated in Service Mode, visual indication of the LED's lighting will be more obvious. Generally, no audible noise is evident as the valves open and close unless the valve is being run against its stop. It is possible to obtain an indication of valve movement by touch, when a valve is opening or closing.

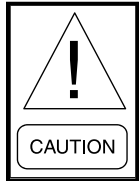

***Manually operating the Feed and Drain Valves in Service Mode can drain or overfill the flash tank. This could cause valve movements and levels in the flash tank to act out of the ordinary when a system first starts, until the Chiller Control Board brings the flash tank level and superheat under control. This may also be evident in the flash tank level and open/close % on the displays. It may also cause the liquid line or flash tank sight glasses to empty or the flash tank sight glass to fill.***

***Careless use of manual control could cause liquid damage to the compressor when it is started.***

## ECONOMIZER CONTROL

The Economizer Solenoid controls a vapor feed to the economizer port on the compressor from the top of the flash tank. When the valve is open, refrigerant gases off in the flash tank providing additional subcooling to the liquid in the tank. The subcooled liquid is then fed to the evaporator resulting in additional system capacity and efficiency.

In normal operation, the Economizer Solenoid on a compressor will be turned on whenever the VSD frequency is more than 120 Hz, the flash tank level is less than 75%, motor current less than 80%FLA, motor temperature sensors are all less than less than 150°F, and the economizer timer is timed out. Whenever the

Economizer Solenoid is turned on, the compressor load timer is set to 35 seconds and economizer timers for every system are set to 30 seconds, unless they are already above 30 seconds.

In low ambient temperatures less than 40°F, run time on the respective compressor is less than 5 minutes, and the flash tank level is less than 75%, the system Economizer Solenoid is turned on. Under these conditions, the VSD frequency and the motor temp sensor readings are not factors that could overload the compressor. Energizing the Economizer Solenoid also helps start a system in low ambients and prevents low suction pressure and low oil differential faults by increasing the load.

At ambients above 40°F, once on, the Economizer Solenoid will remain energized until the VSD frequency drops below 90 Hz. Below 90 Hz, the solenoid will be turned off, regardless of the time remaining on the economizer timers. Under these conditions, the economizer timers will be set to "0" when the solenoids are de-energized. Below 100 Hz, if the economizer timer has timed out, the Economizer Solenoids will be turned off, the unload timer will be set to 30 seconds, the economizer timer will be set to 30 seconds if less than 30 sec.

If a motor temperature sensor exceeds 240 °F, the Economizer Solenoid will de-energize to avoid overheating the hot motor. When the economizer solenoid is de-energized, the compressor unload timer is set to 30 seconds and the economizer solenoid timer is set to 60 seconds. All other economizer timers for other systems are set to 30 seconds, if they are already less than 30 seconds.

The Economizer Solenoid timer prevents the solenoid from cycling too often.

Whenever a compressor is to be turned off, all system Economizer Solenoids will be de-energized when the compressor(s) ramp down. The solenoids on the compressors that will be ramped back up, if any, will remain off for 30 seconds before the Chiller Control Board allows the solenoids to re-energize. Once on, the economizer solenoid(s) must remain on for 30 seconds as determined by the economizer timer for each system.

## FAN LOCATIONS

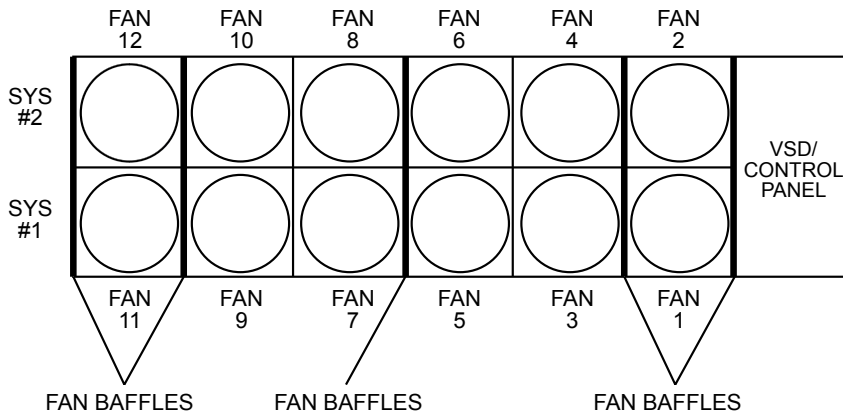

- 11 FAN UNITS - OMIT FAN 12
- 10 FAN UNITS - OMIT FANS 11 & 12
- 9 FAN UNITS - OMIT FANS 10, 11 & 12
- 8 FAN UNITS - OMIT FANS 9, 10, 11 & 12

LD10632

**FIG. 56 - CONDENSER FAN LOCATIONS**

### CONDENSER FAN CONTROL

Condenser Fan control on each system is based on discharge pressure. There are up to five possible stages of fan control utilizing 3 outputs per system. Depending upon the chiller model, there will be 4, 5, or 6 fans per system. The fan nearest the discharge liquid header will always be the first fan on a system to start. As fan stages increment or decrement, a single fan or pair of fans contained within a pair of fan baffles will be turned on or off. The diagram above shows the location of the fan baffles. These baffles will not change location regardless of the number of fans on a chiller.

The fan control algorithm in the Chiller Control Board software will not skip steps as fan stages are staged up and down. The delay between turning on or off fan stages as discharge pressure rises and falls is 5 seconds. The controller increments or decrements the fan stage by one stage based on discharge pressure and fan delay time.

TABLE 11 shows the fan staging and the outputs for each fan stage on 4, 5, and 6 fan systems. The micro-processor fan outputs and the fan contactors will be the same regardless of the number of fans. The fan wiring will change to permit operation of 4, 5, or 6 fans.

**TABLE 11 - FAN STAGES AND CORRESPONDING OUTPUTS**

4 FANS	5 FANS	6 FANS	OUTPUT	CONTACTORS
Stage 1 (1 Fan ON) Sys 1 Fan 1 Sys 2 Fan 2	Stage 1 (1 Fan ON) Sys 1 Fan 1 Sys 2 Fan 2	Stage 2 (2 Fans ON) Sys 1 Fans 1 & 11 Sys 2 Fans 2 & 12)	1	Sys 1: 4CR Sys 2: 7CR
Stage 2 (2 Fans ON) Sys 1 Fans 3 & 5 Sys 2 Fans 4 & 6	Stage 2 (2 Fans ON) Sys 1 Fans 3 & 5 Sys 2 Fans 4 & 6	-	2	Sys 1: 5CR Sys 2: 8CR
Stage 3 (3 Fans ON) Sys 1 Fans 1, 3, & 5 Sys 2 Fans 2, 4 & 6	Stage 3 (3 Fans ON) Sys 1 Fans 1, 3, & 5 Sys 2 Fans 2, 4, & 6	Stage 4 (4 Fans ON) Sys 1 Fans 1, 3, 5, & 11 Sys 2 Fans 2, 4, 6, & 12	1 and 2	Sys 1: 4CR & 5CR Sys 2: 7CR & 8CR
-	Stage 4 (4 Fans ON) Sys 1 Fans 3, 5, 7, & 9 Sys 2 Fans 4, 6, 8, & 10	-	2 and 3	Sys 1: 5CR & 6CR Sys 2: 8CR & 9CR
Stage 4 (4 Fans ON) Sys 1 Fans 1, 3, 5, & 7 Sys 2 Fans 2, 4, 6, & 8	Stage 5 (5 Fans ON) Sys 1 Fans 1, 3, 5, 7, & 9 Sys 2 Fans 2, 4, 6, 8, & 10	Stage 6 (6 Fans ON) Sys 1 Fans 1, 3, 5, 7, 9, & 11 Sys 2 Fans 2, 4, 6, 8, 10, & 12	1, 2, and 3	Sys 1: 4CR, 5CR, & 6CR Sys 2: 7CR, 8CR, & 9CR

Fan on and off control points will vary for standard and optional optimized IPLV chillers. Unless controls dictate all fans running due to high VSD ambient temperatures, fans will sequence on when a compressor runs and discharge pressure rises. During compressor ramp up or ramp down when compressors are staged, the current fan stage will be held.

The number of fans is factory programmable under the password protected Unit Setup Mode.

### Standard IPLV Fan Control

Fan staging ON and OFF points will be determined by the ambient temperature. The fan stage will be incremented, unless the 5 second timer between fan stages is still timing when the discharge pressure rises above the Fan ON Press. The fan stage is decremented, unless the 5 second timer between fan stages is still timing when the discharge pressure falls below the Fan OFF Press. When a fan stage is incremented, the fan delay timer is set to 5 seconds, and the Fan ON pressure is ramped 20 PSIG over the original ON point back to the original value over the next 20 seconds. When a fan stage is decremented, the fan delay timer is set to 5 seconds, and the Fan OFF pressure is ramped 20 PSIG below the original Fan OFF point, back to the original value over the next 20 seconds. The ON and OFF points will vary as ambient temperature changes. FIG. 57 below shows the fan ON and OFF points relative to ambient temperature.

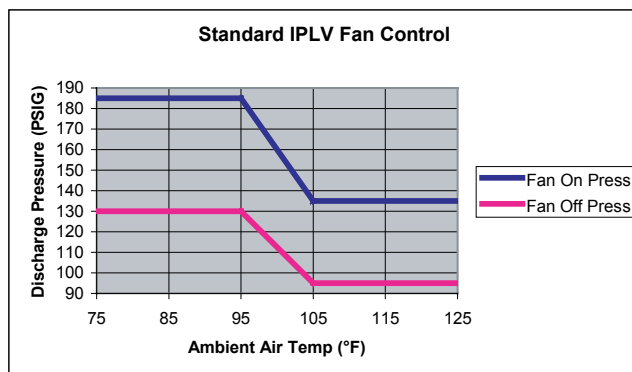

FIG. 57 - STANDARD IPLV FAN CONTROL

### Optimized IPLV Fan Control

Fan staging ON and OFF points will be determined by the ambient temperature. The fan stage will be incremented, unless the 5 second timer between fan stages is still timing when the discharge pressure rises above the Fan ON Press. The fan stage is decremented, unless the 5 second timer between fan stages is still

timing when the discharge pressure falls below the Fan OFF Press. When a fan stage is incremented, the fan delay timer is set to 5 seconds, and the Fan ON pressure is ramped 20 PSIG over the original ON, point back to the original value over the next 20 seconds. When a fan stage is decremented, the fan delay timer is set to 5 seconds, and the Fan OFF pressure is ramped 20 PSIG below the original Fan OFF point, back to the original value over the next 20 seconds. The ON and OFF points will vary as ambient temperature changes. FIG. 58 below shows the fan ON and OFF points relative to ambient temperature.

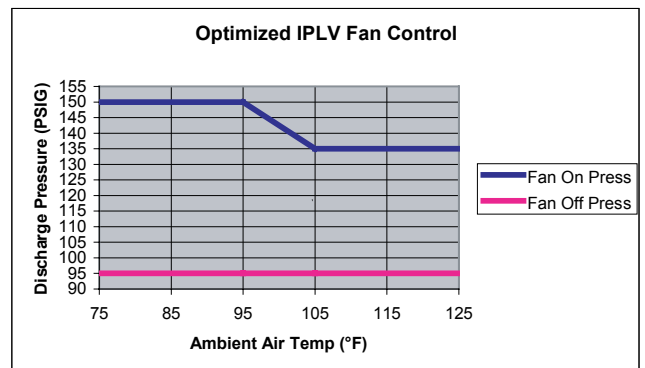

FIG. 58 - HIGH IPLV FAN CONTROL

### High VSD Cabinet Ambient Temperature Fan Operation

All condenser fans on all systems will run when the chiller is off and enabled to run, if the VSD internal ambient temperature is higher than 5°F below the VSD Cabinet Ambient Temperature Cutout of 158°F (158°F minus 5°F equals 153 °F). When the fans turn on in this situation, the fan outputs will cycle one at a time with a 100 ms delay between fan starts. When the VSD internal ambient falls below the “Restart Temperature” (158°F Cutout minus 10°F equals 148 °F), the fans will all be turned off without a delay.

### VSD TEMPERATURE CONTROL, OPERATION OF THE COOLANT PUMP, AND VSD CABINET COOLING FANS

The Coolant pump and VSD Cabinet Cooling Fans will run to cool the VSD whenever any of the following conditions are met:

- VSD Comp IGBT Baseplate Temperature on a 2 or 4 compressor unit is greater than 10°F (5.6°C) below the cutout (Cutout 218°F [103.3°C] minus 10°F [5.6°C] equals 208°F [97.8°C]). When the VSD internal ambient falls below the restart temperature (Cutout 218°F [103.3°C] minus 15°F [8.3°C] equals 203°F [95°C]), the fans and pump will turned off without a time delay.

- VSD Comp IGBT Baseplate Temperature on a 3 compressor unit is greater than 10°F (5.6°C) below the cutout (cutout 232°F [111.1°C] minus 10°F (5.6°C) equals 222°F [105.6°C]). When the VSD internal ambient falls below the restart temperature (cutout minus 15°F [8.3°C] equals 217°F [102.8°C]), the fans and pump will be turned off without a time delay.
- Pre-charge Enable 1 from the Chiller Logic Board is ON.
- Pre-charge Enable 2 from the Chiller Logic Board is ON.
- VSD Internal Ambient Temp more than 158°F (70.0°C) (Cutout) – 10°F (5.6°C) equals 148°F (64.4°C). When the Internal Ambient Temp falls to less than 158°F (70.0°C) (Cutout) minus 15°F (8.3°C) equals 143°F (61.7°C) the VSD cooling fans and glycol pump will turn off.
- Condenser Fans (as needed) and VSD coolant pump/fans will run whenever a compressor is running. Under these conditions, the condenser fans will run to control discharge pressure and the VSD coolant pump/fans will run to cool the IGBT baseplate and internal cabinet. Additional condenser fans will be brought on, if the IGBT baseplate temperatures or internal cabinet ambient rises to 5°F (2.8°C) below the cutout. Condenser fans will turn off, if the compressor turns off provided VSD cooling is not required. The glycol pump and cabinet fan may continue to run, if VSD cooling is required.
- Glycol Pump and Cabinet Cooling Fans will also run in the Service Mode if the Fan/Pump Run Bit is Set.

## REMOTE TEMPERATURE RESET CONTROL

### Temperature Reset Control

Temperature Reset Control is used to reset the actual LCHLT (Leaving Chilled Liquid Temperature) setpoint used in capacity control. There are several ways to change the LCHLT setpoint. The first is by re-programming the Local Cooling Setpoint under the SETPOINTS key. This is the value the unit will control the LCHLT to if neither of the other methods is active.

Remote Temperature Limit Reset is only possible if the option is enabled by both the OPTIONS key selection and in the factory programmable password protected Unit Setup Mode.

### Remote ISN Setpoint Control

The Remote Leaving Chilled Liquid Setpoint Cooling Setpoint can be set via the ISN comms. The control panel will only accept a remote setpoint from the ISN if the control panel is in Remote Control Mode (under the OPTIONS key). If the control panel is in Local Control Mode, the ISN setpoint will be ignored and the Remote Cooling Setpoint is set to the Local Cooling Setpoint. The minimum and maximum allowable reset values will be the same as the minimum and maximum allowable programmable values for the Local Cooling Setpoint. If these values are exceeded by the ISN, the minimum or maximum value will be used.

Contact a local YORK ISN Representative for details on ISN controls and capabilities.

### Remote Temperature Reset

The Remote Leaving Chilled Liquid Cooling Setpoint can be reset via the Remote Temperature Reset analog input. A zero signal input (0% input) equates to a 0°F offset to the Local Cooling Setpoint. A full scale signal input (100% input) equates to a "positive" offset to the Local Cooling setpoint equal to the programmable Maximum Remote Temp Reset. The offset is linear and may be adjusted anywhere between the 0% and 100% points. The maximum setpoint allowed is the maximum programmable Local Cooling Setpoint and will be capped at this value, if the calculated setpoint with temperature offset exceeds this value.

This input may be used either in Local or Remote Control Mode. This feature will only operate if enabled under the UNIT SETUP and the OPTIONS key. The input will be ignored if the Remote Temp Reset is disabled under the OPTIONS key or if there are valid ISN comms while in Remote Control Mode. Once a change to the input is registered, a timer is set to the value of the Remote Inputs Service Time as programmable under the Unit Setup Mode at the factory for the default value of 15 minutes. The low limit is 5 minutes and the high limit is 60 minutes. The Remote input will be ignored until this timer expires. The timer assures that rapid changes in a remote reset signal don't result in poor temperature control or excessive compressor cycling. In most instances, this timer will not need to be changed, since reset more often than 15 minutes will create problems with chilled liquid temperature control. Factory Service should be contacted if a timer change is required.

Control Board jumper JP4 must be positioned correctly to receive either a voltage (0 through 10VDC or 2 through 10VDC) or current (0 through 20mA or 4 through 20mA) signal. Place the jumper in the “V” position for a voltage signal or mA for a current signal (See FIG. 26 and 27). The software must be configured under the OPTIONS key for the specific type of input signal to be used.

The maximum temperature reset is achieved at either 10VDC or 20mA. Sending the minimum signal (0VDC, 2VDC, 0mA, or 4mA based on the OPTIONS key setting) causes the setpoint to revert back to its local programmed value. If the setpoint reset causes the setpoint to go over the maximum programmable value, it will be set to the maximum programmable setpoint.

#### **0 through 10VDC Reset Input**

A 0VDC signal produces a 0°F reset. A 10VDC signal produces the maximum remote temp reset (programmable under the SETPOINTS key). The setpoint reset is ramped linearly between these limits as the input varies between 0VDC and 10VDC. In order for this input to work properly, the Remote Temperature Reset must be programmed for 0 through 10VDC input (OPTIONS key) and Chiller Control Board jumper JP4 placed in the “V” position.

#### **2 through 10VDC Reset Input**

A 0 - 2VDC signal produces a 0°F reset. A 10VDC signal produces the maximum remote temp reset (programmable under the SETPOINTS key). The setpoint reset is ramped linearly between these limits as the input varies between 2VDC and 10VDC. In order for this input to work properly, the Remote Temperature Reset must be programmed for 2 through 10VDC input (OPTIONS key) and Chiller Control Board jumper JP4 placed in the “V” position.

#### **0 through 20mA Reset Input**

A 0mA signal produces a 0°F reset. A 20mA signal produces the maximum remote temp reset (programmable under the SETPOINTS key). The setpoint reset is ramped linearly between these limits as the input varies between 0mA and 20mA. In order for this input to work properly, the Remote Temperature Reset must be programmed for 0 through 20mA input (OPTIONS key) and Chiller Control Board jumper JP4 placed in the “mA” position.

#### **4 through 20mA Reset Input**

A 0 - 4mA signal produces a 0°F reset. A 20mA signal produces the maximum remote temp reset (programmable under the SETPOINTS key). The setpoint reset is ramped linearly between these limits as the input varies between 4mA and 20mA. In order for this input to work properly, the Remote Temperature Reset must be programmed for 4 through 20mA input (OPTIONS key) and Chiller Control Board jumper JP4 placed in the “mA” position.

#### **Local Current Limit Control**

Local Current Limit Control is used to set the actual Current Limit Setpoint. This is accomplished by changing the Local Current Limit Setpoint under the PROGRAM key. This is the value at which the unit will begin to current limit and override capacity control if remote reset is not actively overriding this control. If any other current limit methods are active, the lowest value will be used.

Keep in mind that limiting current may interfere with capacity control, pulling down chilled liquid temperatures on hot water starts, and maintaining chilled liquid setpoints.

#### **Pulldown Current Limit Setpoint**

The Pulldown Current Limit Setpoint can be set under the PROGRAM key. This current limit setpoint is only active on start-up for the time defined by the Pulldown Current Limit Time under the PROGRAM key. After the run time has exceeded this time, the Pulldown Current Limit Setpoint is ignored.

This control is useful in limiting current pulldown demand during peak usage periods where electric costs are highest.

Keep in mind that limiting current may interfere with capacity control, pulling down chilled liquid temperatures on hot water starts, and maintaining chilled liquid setpoints.

#### **REMOTE CURRENT LIMIT RESET CONTROL**

Remote Current Limit Reset is used to reset the actual current limit setpoint used in current limit control. There are several ways to change the current limit setpoint. The first is by reprogramming the Local Current Limit Setpoint under the PROGRAM key. This is the value the unit will control the current limit to if neither of the other methods is active.

Remote Current Limit Reset is only possible if the option is enabled by both the OPTIONS key selection and in the factory programmable password protected Unit Setup Mode.

### Remote ISN Current Limit Setpoint

The ISN Current Limit Setpoint can be set via the ISN comms. The control panel will only accept a Current Limit Setpoint from the ISN if the control panel is in Remote Control Mode (under the OPTIONS key). If the control panel is in Local Control Mode, the ISN setpoint will be ignored. The minimum and maximum allowable values will be the same as the minimum and maximum allowable reset values for the Current Limit Setpoint under the PROGRAM key. If these values are exceeded, the minimum or maximum value will be used.

Contact a local Johnson Controls ISN Representative for details on ISN controls and capabilities.

### Remote Current Limit Reset

The Current Limit Setpoint can be set or reset via the Remote Current Limit analog input. A zero signal input (0% input) equates to the maximum current limit setpoint as defined under the PROGRAM key Current Limit Setpoint. A full scale signal input (100% input) equates to the minimum current limit setpoint as defined under the PROGRAM key Current Limit Setpoint. The current limit value is linear and may be adjusted anywhere between the maximum and minimum points of 0 (no offset) and 100% (max. current limiting).

This input may be used either in Local or Remote Control Mode. This input will be ignored if the Remote Current Limit is disabled under the OPTIONS key. Once a change to the input is registered, a timer is set to the value of the Remote Inputs Service Time as programmable under the Unit Setup Mode at the factory for the default value of 15 minutes. The low limit is 5 minutes and the high limit is 60 minutes. The Remote input will be ignored until this timer expires. The timer assures that rapid changes in a remote reset signal don't result in poor temperature control or excessive compressor cycling. In most instances, this timer will not need to be changed, since reset more often than 15 minutes will create problems with chilled liquid temperature control. Factory Service should be contacted if a timer change is required.

Control board jumper JP5 must be positioned correctly to receive either a voltage (0 to 10VDC or 2 to 10VDC) or current (0 to 20mA or 4 to 20mA) signal. Place the jumper in the "V" position for a voltage signal or mA for a current signal (*See FIG. 26 and 27*). The software must be configured under the OPTIONS key for the type of input signal to be used.

The minimum current limit setpoint is achieved at either 10VDC or 20mA. Sending the minimum signal (0VDC, 2VDC, 0mA, or 4mA based on the OPTIONS key setting) causes the current limit to revert back to its maximum value.

#### **0 through Reset Input**

A 0VDC signal sets the current limit to the maximum value. A 10VDC signal sets the current limit to the minimum value. The current limit is ramped linearly between these limits as the input varies between 0VDC and 10VDC. In order for this input to work properly, the Remote Current Limit must be programmed for 0 through 10VDC input (OPTIONS key) and Chiller Control Board jumper JP5 placed in the "V" position.

#### **2 through 10VDC Reset Input**

A 0 - 2VDC signal sets the current limit to the maximum value. A 10VDC signal sets the current limit to the minimum value. The current limit is ramped linearly between these limits as the input varies between 2VDC and 10VDC. In order for this input to work properly, the Remote Current Limit must be programmed for 2 through 10VDC input (OPTIONS key) and Chiller Control Board jumper JP5 placed in the "V" position.

#### **0 through 20mA Reset Input**

A 0mA signal sets the current limit to the maximum value. A 20mA signal sets the current limit to the minimum value. The current limit is ramped linearly between these limits as the input varies between 0mA and 20mA. In order for this input to work properly, the Remote Current Limit must be programmed for 0 through 20mA input (OPTIONS key) and Chiller Control Board jumper JP5 placed in the "mA" position.

#### **4 through 20mA Reset Input**

A 4mA signal sets the current limit to the maximum value. A 20mA signal sets the current limit to the minimum value. The current limit is ramped linearly between these limits as the input varies between 4mA and 20mA. In order for this input to work properly, the Remote Current Limit must be programmed for 4 through 20mA input (OPTIONS key) and Chiller Control Board jumper JP5 placed in the "mA" position.

## SOUND LIMIT CONTROL

(Local and Remote Reset Control)

### Sound Limiting and Local Sound Limit Setpoint

Sound limit control to reduce overall chiller noise levels at specified times of the day is accomplished by setting a Sound Limit Setpoint. There are several ways to set the Sound Limit Setpoint. The first is by changing the Local Sound Limit Setpoint under the PROGRAM key. This is the value the unit will use for sound limiting, if neither of the other methods is active. If any other sound limit methods are active, the lowest value will be used. A sound limit of 0% will allow the unit to run up to the unit's maximum frequency. A sound limit of 100% will not allow the unit to run above the minimum frequency. All other sound limit values are linear between these 2 points.

A sound limit schedule must be programmed under the SCHEDULE key when sound limiting is utilized. The schedule defines the time period that sound limiting will be active.

Sound Limiting is only possible if the option is enabled by both the OPTIONS key selection and the factory programmable password protected Unit Setup Mode.

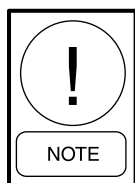

***If Sound Limiting is disabled under the Unit Setup Mode, nothing relating to Sound Limiting will show up on any display screen or printout.***

### ISN Sound Limit Setpoint

The ISN Sound Limit Setpoint can be set via the ISN II comms. The control panel will only accept a Sound Limit Setpoint from the ISN if the control panel is in Remote Control Mode. If the control panel is in Local Control Mode, the ISN setpoint will be ignored. The minimum and maximum allowable values will be the same as the minimum and maximum allowable values for the Sound Limit Setpoint under the PROGRAM key. If these values are exceeded, the minimum or maximum value will be used.

Contact a local Johnson Controls ISN Representative for details on ISN controls and capabilities.

### Remote Sound Limit

The Sound Limit Setpoint can be set via the Remote Sound Limit analog input. A zero signal input (0% input) equates to the minimum sound limit setpoint as defined under the PROGRAM key Sound Limit Setpoint. A full scale signal input (100% input) equates to the maximum sound limit setpoint as defined under the PROGRAM key Sound Limit Setpoint. The input is linear and may be adjusted between 0% (minimum sound limiting) and 100% (maximum sound limiting) points.

This input may be used either in Local or Remote Control Mode. The input will be ignored if the Remote Sound Limit is disabled under the OPTIONS key. Once a change to the input is registered, a timer is set to the value of the Remote Inputs Service Time as programmable under the Unit Setup Mode at the factory for the default value of 15 minutes. The low limit is 5 minutes and the high limit is 60 minutes. The Remote input will be ignored until this timer expires. The timer assures that rapid changes in a remote reset signal don't result in poor temperature control and excessive compressor cycling. In most instances, this timer will not need to be changed, since reset more often than 15 minutes will create problems with chilled liquid temperature control. Factory Service should be contacted if a timer change is required.

Control board jumper JP6 must be positioned correctly to receive either a voltage (0 to 10VDC or 2 to 10VDC) or current (0 to 20mA or 4 to 20mA) signal. Place the jumper in the "V" position for a voltage signal or mA for a current signal (*See FIG. 26 and FIG. 27*). The software must be configured under the OPTIONS key for the type of input signal to be used.

The maximum sound limit is achieved at either 10VDC or 20mA. Sending the minimum signal (0VDC, 2VDC, 0mA, or 4mA based on the OPTIONS key setting) causes the sound limit to be set to its minimum (no limiting) value.

### 0 through 10VDC Reset Input

A 0VDC signal produces a 0% sound limit (no change to max VSD freq). A 10VDC signal produces a 100% sound limit (max VSD freq equals min VSD freq). The sound limit is ramped linearly between these limits as the input varies between 0VDC and 10VDC. In order for this input to work properly, the Remote Sound Limit must be programmed for 0 through 10VDC input (OPTIONS key) and Chiller Control Board jumper JP6 placed in the "V" position.

**2 through 10VDC Reset Input**

A 0 through 2VDC signal produces a 0% sound limit (no change to max VSD freq). A 10VDC signal produces a 100% sound limit (max VSD freq equals min VSD freq). The sound limit reset is ramped linearly between these limits as the input varies between 2VDC and 10VDC. In order for this input to work properly, the Remote Sound Limit must be programmed for 2 through 10VDC input (OPTIONS key) and Chiller Control Board jumper JP6 placed in the “V” position.

**0 through 20mA Reset Input**

A 0mA signal produces a 0% sound limit (no change to max VSD freq). A 20mA signal produces a 100% sound limit (max VSD freq equals min VSD freq). The sound limit reset is ramped linearly between these lim-

its as the input varies between 0mA and 20mA. In order for this input to work properly, the Remote Sound Limit must be programmed for 0 through 20mA input (OPTIONS key) and Chiller Control Board jumper JP6 placed in the “mA” position.

**4 through 20mA Reset Input**

A 0 through 4mA signal produces a 0% sound limit (no change to max VSD freq). A 20mA signal produces a 100% sound limit (max VSD freq equals min VSD freq). The sound limit reset is ramped linearly between these limits as the input varies between 4mA and 20mA. In order for this input to work properly, the Remote Sound Limit must be programmed for 4 through 20mA input (OPTIONS key) and Chiller Control Board jumper JP6 placed in the “mA” position.

## SECTION 8 - MICROPANEL

### VSD OPERATION AND CONTROLS

#### VSD Logic Board

The VSD Logic Board communicates with the Chiller Control Board via comms and controls the VSD functions. It converts the frequency and run commands from the Chiller Control Board into the necessary voltage and frequency commands to operate the inverter section. It also controls the converter section of the drive (AC Line to DC Bus conversion) by controlling the pre-charge function.

The VSD Logic Board contains a 2nd microprocessor (motor controller) that generates the PWM signals that control the IGBT outputs in the inverter section of the VSD.

An FPGA handles the hardware safeties that can shut down the VSD much faster than the software safeties. The VSD Logic Board handles all of the VSD related safeties, which includes motor current, BUS voltage, and other safeties.

The VSD Logic Board reports shutdown information back to the Chiller Control Board via the RS-485 communication link.

2, 3 and 4 compressor chillers all use the same software. The microprocessor determines whether the chiller is a 2, 3 or 4 compressor chiller by electronically checking for a factory-installed jumper in the system wiring harness. The microprocessor checks for the jumper located in the J1 plug wiring harness at power-up. If no jumper or more than one jumper is sensed, the microprocessor will inhibit start-up. Details regarding the location of the jumper are provided on Page 210 in the “Chiller Configuration Jumpers” section.

#### VSD Start/run Initiation

Following a successful precharge of the DC Bus and a run command from the Chiller Control Board, the VSD Logic Board microprocessor will determine the motor output voltage (% modulation) and the output frequency required based on the operating frequency command from the Chiller Control Board. This information will then be sent to the PWM generator located on the VSD Logic Board.

On start-up, the output frequency from the VSD to the motor(s) will be increased from 0 Hz to the operating frequency commanded by the Chiller Control Board. The rate of change of the frequency will also be controlled by the VSD Logic Board.

The rate of change of the output frequency at start-up, during acceleration is 10 Hz/sec between 0 and 50 Hz and 30.4 Hz/sec above 50 hertz. The maximum rate of change of the output frequency during deceleration between 200 and 100 Hz is 30.4 Hz/sec, and 100 and 0 Hz is 10 Hz/sec.

The VSD Logic Board and its PWM generator will receive operating frequency and voltage commands from the Chiller Control Board based on the load.

When a frequency (speed) change is requested from the Chiller Control Board, the chiller microprocessor will send the change to the VSD Logic Board and the VSD Logic Board will acknowledge it accepted the change. Loading and unloading will take place at the rate of 0.1 to 1Hz every 2 seconds.

#### PWM Generator Type and Carrier Frequency

The PWM generator is responsible for providing asymmetrical uniform sampled PWM waveforms to the compressor motor at a carrier frequency of 3125 Hz by turning on an off the inverter IGBT's. The waveform generated is equivalent to a specific V/F ratio at a given speed based on the voltage and frequency commands from the Chiller Control Board. The PWM Generator receives operating frequency and voltage commands from the VSD Logic Board control processor.

#### Short Circuit Protection Minimum Output Pulse Width and Interlock Delay

The PWM generator is programmed to drop all “on” pulses in less than 10 microseconds (and all matching “off” pulses in the mirrored waveform) to permit time for the IGBT gate drivers to detect and self extinguish an inverter short circuit condition.

#### Modulating Frequency

The modulating frequency range will range from 0 to 200 Hz. The modulating frequency waveform consists of a sinusoidal waveform summed together with 16.66% of the third harmonic component of the sinusoidal waveform. Utilization of this waveform as the modulating waveform will permit the drive to generate a fundamental line to line voltage equal to the DC Bus voltage divided by 1.414.

## Maximum VSD Frequency

The maximum VSD frequency will vary for each chiller model. The microprocessor board determines the frequency according to jumpers' factory installed in the wiring on the J7 plug of the microprocessor board. The location of these jumpers' is interpreted as a binary value, which presently allows 7 speed selections plus a default. The maximum frequency may vary from 178 to 200 Hz. If the J7 plug is not installed, the speed will default to 178 Hz. Details on the location of the jumpers' and the associated maximum speed are provided on Page 210 in the "Chiller Configuration Jumpers" section.

## VSD % Modulation

The voltage and frequency commands issued by the VSD Logic Board microprocessor are determined by the frequency command from the Chiller Control Board. The VSD output is a PWM signal (FIG. 2), which has effects on the motor comparable to an AC voltage sinusoidal waveform. To change the speed of an AC motor, the frequency of the AC voltage must be changed. Whenever frequency is changed, the voltage is changed in a linear ratio. Maintaining a relatively constant V/F ratio as speed changes assures motor losses and overheating do not occur.

The output voltage of the VSD is not a sinusoidal waveform. Instead, the PWM generator provides an output that simulates a true AC waveform by repetitively turning on and off the voltage to the motor to create an average voltage that is equal to a lower AC voltage at lower frequencies and a higher voltage at higher frequencies. The PWM generator also changes the % modulation of the waveform to simulate the frequency change to maintain the V/F ratio with motor speed changes.

The PWM generator is programmed to essentially operate a linear volts/Hz ratio over the 0 to 200 Hz frequency range. The complex control algorithm modifies the voltage command to boost the voltage of the V/F ratio at lower speeds to provide additional torque.

The 100% modulation operating point occurs at a fundamental frequency of 189.6 Hz. As the output frequency increases above 189.6 Hz, the drive operates in an over-modulated mode. For example, at 200 Hz fundamental modulating frequency the PWM waveform is over-modulated by approximately 18%. This will yield a fundamental output line to line voltage applied to the

motor terminals at maximum output frequency that is equal to the input line to line voltage applied to the drive (provided the DC Bus current remains continuous).

## VSD Cooling and Cooling Loop

The VSD generates heat in the IGBT power modules and the SCR/Diode assemblies, which must be removed. The heat not only heats the modules but also the Micro/VSD cabinet.

The VSD is cooled by a glycol loop and circulating pump. The glycol cooling loop feeds a liquid cooled heatsink called a chillplate that cools the IGBT's and SCR/Diode modules. The coolant is pumped by a circulator pump through the heatsink where it absorbs heat in several passes of tubes on the lower rows of the inside condenser coils where the condenser fans remove the heat picked up from the modules. The coolant is then pumped back to the modules. The glycol loop also provides cooling for the Micro/VSD cabinet. The baseplates of the power components are mounted to the glycol cooled heatsinks in the cooling loop. The cooling loop also circulates the glycol through a cooling coil in the cabinet. A fan blows air from the cabinet across the cooling coil to cool the electronics in the cabinet.

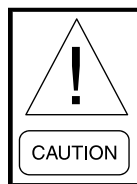

***Never run the glycol pump without coolant! Running the glycol pump without coolant may damage the pump seals***

***Always fill the system with approved coolant to avoid damage to the pump seals and other components.***

***Heat transfer characteristics of the coolant are very critical. Substituting coolant or adding water will result in cooling loop performance loss and chiller shutdown.***

The glycol coolant level in the VSD cooling system should be maintained between 9 and 15 inches (23 and 38 cm) from the top of the fill tube. This check should be performed prior to running the pump. The pump can be test run by placing the chiller in Service Mode. It is advisable to fill the tube to the required level before starting the glycol pump because it may empty

when the pump starts. The level should be topped off as needed while running. Be sure to re-install the cap before stopping the glycol pump to avoid overflowing the fill tube when the glycol pump is turned off.

Glycol coolant has a defined operating life. System coolant should be changed 5 years from date of shipment of the equipment. Mixing other coolants or water with the special glycol will reduce the life of the coolant, and cause VSD overheating and damage.

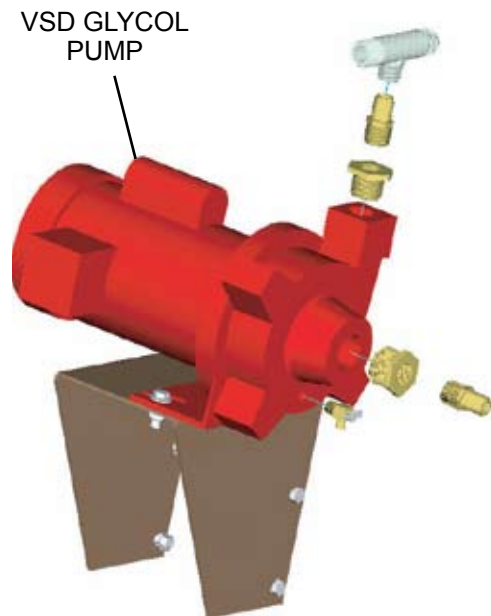

LD10635

The VSD fan and glycol pump will run if any of the following conditions listed below are true, provided the VSD has been powered up for less than 30 seconds and the pump has not run in the last 30 seconds. The 30 second limitations prevent pump motor overheating.

- 2 and 4 Compressor Baseplate temp is more than Cutout (218°F) minus 10°F.
- 3 Compressor IGBT Baseplate temp is more than Cutout (232°F) minus 10°F.
- Pre-charge Enable 1 from the Chiller Logic Board is ON.
- Pre-charge Enable 2 from the Chiller Logic Board is ON.
- VSD Internal Ambient Temp more than Cutout minus 10°F.
- Any compressor is running.
- Service Mode Fan/Pump Run is enabled.

The VSD fan/glycol pump will turn off when ALL of the following conditions are true:

- Compressor 1/3 IGBT Baseplate temp is less than Cutout minus 15°F.
- Compressor 2/4 IGBT Baseplate temp is less than Cutout minus 15°F.
- Pre-charge Enable 1 from the Chiller Logic Board is OFF.
- Pre-charge Enable 2 from the Chiller Logic Board is OFF.
- VSD Internal Ambient Temp less than Cutout minus 15°F.
- No compressors are running.
- Service Mode Fan/Pump is disabled.

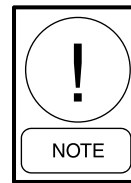

***In some cases, the condenser fans may be turned on by the microprocessor, when no compressors are running, to keep the power components and Control/VSD Cabinet from overheating.***

8

### IGBT Module Baseplate Temperature Sensing

Each IGBT module has an internal 5Kohm thermistor built in to measure the temperature of the module. Up to 4 thermistors are connected to the VSD Logic Board (one per compressor). The highest module temperature of compressors 1 and 3 are sent to the logic board along with the highest module temperature of compressors 2 and 4. If the temperature exceeds the software trip point, the unit will shut down on a safety. See “High Baseplate Temperature Fault” (Page 241) for details.

LM 34  
SENSOR

LD10615

ORIGINAL - OBSOLETE P/N 031-02477-000

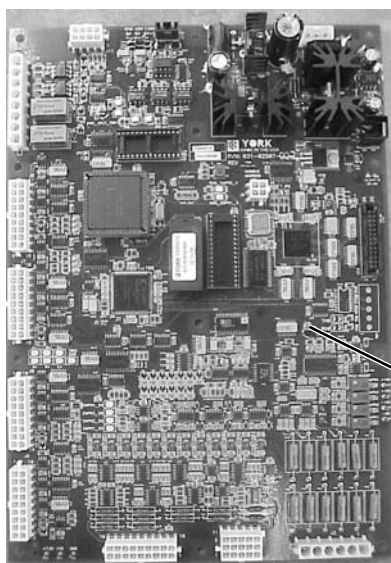
LM 34  
SENSOR

LD13123

NEW BOARD - P/N 031-02507-XXX

### VSD Internal Ambient Temperature Sensing

A National LM34 temperature sensor located on the VSD Logic Board is used to measure the internal ambient temperature of the Control Panel/VSD enclosure. It has an output voltage that is linearly proportional to the temperature in degrees Fahrenheit. If the temperature exceeds the software trip point, the unit will shut down on a safety. See “High VSD Ambient Temperature Fault” (Page 241) for details.

### Pre-charge

When cooling is required (LCWT is more than SPHL, leaving chilled liquid temp is greater than the setpoint high limit), the chiller Control Board will send a Pre-Charge Enable (2 enables on a 4 comp unit) via comms to the VSD Logic Board. The VSD’s DC Bus voltage(s) across the Bus Filter Capacitors will slowly be increased to the proper level (more than 500VDC) through firing of the SCR Trigger Board(s) and the associated pre-charge enable control signal(s). The pre-charge time interval is fixed at 20 seconds. The purpose of the precharge is to limit current when charging an uncharged capacitor bank. When uncharged, the capacitor bank looks like an electrical short. The bus is brought up slowly by only turning on the SCR’s during the trailing half of the + and – portion of the incoming AC sine wave. Following is the status message displayed while the precharge is taking place.

**SYS X VSD DC BUS PRECHARGE**

Following successful completion of the pre-charge interval, the SCR’s on the AC to DC semi-converter (SCR/Diode Modules) will be gated fully on by the SCR Trigger Board and the DC Bus will be brought up to its full potential. After pre-charge has been successfully completed, the SCR’s will stay fully on until the Chiller Control Board turns off the Pre-Charge Enable via comms.

There will be a Unit Pre-charge Enable for 2 and 3 compressor units and separate System Pre-charge Enables for 4 compressor units.

The pre-charge will only take place when all of the following conditions are true, otherwise it is disabled:

- Daily Schedule is ON.
- UNIT switch is ON.
- System Switch(es) are ON.
- Run Permissive(s) are Enabled.
- Flow Switch indicates flow.
- LCHLT more than Setpoint High Limit.
- Unit not faulted / locked out.

### Run Mode / Unit Restart

In order to initiate a system run, two conditions must be met. At least 1 of the 2 systems run signals from the control panel must be present and at least 1 of the 4 possible Compressor RUN bits must be set in the serial communications link between the VSD Logic Board and the Chiller Control Board. Following successful completion of pre-charge and receipt of the system run signals, the motor output voltage (% modulation) and output frequency commands will be determined by the VSD microprocessor located on the VSD Logic Board. These two parameters will be sent to the PWM generator located on the VSD Logic Board for waveform processing at a rate of once every 10 msec.

The voltage and frequency commands issued by the VSD microprocessor are determined by the operating frequency command received on the communications link from the Chiller Control Board and by the present operating frequency of the drive. Upon receipt of a legitimate run command communication, the VSD’s output frequency will be increased from 0 Hz to the operating frequency command from the communications link.

## DC Bus Voltage Sensing and Scaling

Full DC Bus voltage and ½ DC Bus voltages are sensed for up to 2 DC Buses. 2 and 3 compressor chillers share a common DC Bus, while 4 compressor chillers utilize 2 DC Buses (1/3 and 2/4). The DC Bus is wired to the DC Bus Isolation Board, the voltage is divided down through a resistance voltage divider, and the reduced voltage is fed to the VSD Logic Board for safety monitoring.

## Current Sensing and Scaling

Individual current transformers on each leg sense three phases of output current on each compressor. These signals are buffered, divided by 2, and filtered by an RMS to DC converter. The highest of the currents in the three phases of each compressor leaving the RMS converters is then sent to an A-D converter scaled, monitored by the VSD Logic Board overload and high current protection circuitry, and sent to the Chiller Control Board for display as the compressor current.

In order to set the motor overload level (determined by the setting of the OVERLOAD ADJUST potentiometer on the VSD Logic Board), the voltage level on the wipers of the four OVERLOAD ADJUST potentiometers is continuously sensed by the VSD Logic Board for current protection and sent to the Chiller Control Board for both display purposes and for current limiting control. This parameter is the 105% FLA value.

## VSD Transmitted Operating Parameters

VSD operating parameters will be transmitted to the Chiller Control Board over the RS-485 communications link between the 2 boards. These values will be displayed on the control panel display. The data and display format are outlined in the TABLE 12 below.

## VSD SAFETIES (FAULTS)

VSD operating conditions are monitored by both software algorithms and hardware circuitry. Both types exist as a result of the need for both extremely fast protection requirements such as a short circuit condition or a slow reacting trip such as a slow rising overload condition. To eliminate nuisance unit trips, the sensor inputs for the VSD's operating parameters are averaged four times before "Software" generated unit/system fault trips from the VSD Logic Board are initiated. These faults cause single compressor or total unit controlled "ramped" shutdown. Other parameters that are not fed to the VSD Logic Board microprocessor are protected by "Hardware" generated fault trips. Hardware trips involve electronic circuitry that measures voltages or currents and activate level sensitive comparators connected to programmable gate arrays on the VSD Logic Board FPGA (Field Programmable Gate Array). These safeties operate extremely fast and provide "immediate" shutdown, because they are not dependent upon software program loops that operate in seconds or fractions of a second. Outputs from the gate arrays provide a digital signal to indicate whether a safety threshold has been reached.

**TABLE 12 - VSD OPERATING DISPLAY PARAMETERS**

DATA	DISPLAY FORMAT
Highest Phase of Compressor Motor Current in Amperes RMS (per Compressor)	XXX Amps
VSD Output Frequency	XXX.X Hz
Motor Overload Setting (105% FLA potentiometer setting) in amperes RMS(per Compressor)	XXX Amps
DC Bus Voltage in DC Volts (maximum of 2)	XXX Volts
VSD Internal Ambient Temperature	XXX.X°F (or °C)
IGBT Power Assembly Power Module Highest Baseplate Temperature (maximum of 2)	XXX.X°F (or °C)
Pre-Charge Enable Signal (maximum of 2)	On or OFF
VSD cooling Fan/Pump	On or OFF
Compressor Run Status (maximum of 4)	On or OFF

Immediate Fault shutdowns are often accompanied by audible motor backspin due to equalizing of the differential between discharge and suction when the compressor is turned off while rotating at high speeds. This should not cause concern and will not damage the chiller.

Each fault outlined in the descriptions that follow will indicate whether it is a hardware or software generated fault.

It will be noted the “ramped” shutdown results in minimal compressor backspin and noise associated with backspin. “Immediate” shutdowns will result in compressor backspin and a higher noise level based upon the differential pressure between discharge and suction.

When a VSD fault occurs, the VSD Logic Board captures VSD data in the onboard battery backed RAM. At the same time, the VSD Board “Fault Relay” will open, signaling the Chiller Control Board microprocessor to save a snapshot of system data. The VSD Logic Board then transmits the fault data to the Chiller Control Board microprocessor on the next comms between the two boards. If the Chiller Control Board receives the comms fault indication before the Fault Relay signal, it will immediately save a snapshot of system data when the comms fault is recognized. This also enables the microprocessor to capture fault data if the Fault relay fails. Both the system and VSD fault data are then stored in the Chiller Control Board history buffers. Any additional faults that may occur during shutdown on the first fault or between the first fault and the next comms will also be stored and transmitted to the Chiller Control Board along with the original fault data. This data will be stored as “ALL FAULT” data.

When the control panel acknowledges a fault (via the fault acknowledge bit in comms) the fault relay will be reset (closed) by the VSD Logic Board and the fault indication flag (in comms) will be reset.

The fault relay will not open when a non-running fault occurs. In this case, the system will be inhibited from running until the fault condition is corrected. An inhibit message will be displayed on the panel display indicating the system is not allowed to run. Examples of this type of fault would be the High Internal Ambient fault and the VSD CT Plug Fault. When the chiller

receives the transmitted fault data via comms, it will save a snapshot of system data in the history buffer even though the chiller is not running.

Some faults will be unit faults; other faults will be system (specific compressor or compressor pairs) faults, depending upon the number of compressors in the chiller. Most faults will shut down the unit/ system and allow restart once the fault clears and the 120 sec anti-recycle timer times out. These faults will allow up to 3 faults in 90 minutes before locking out the unit/ system. Other faults lock out the unit/system after only a single fault. Details on individual faults are provided in the following explanations.

A start inhibit will take place if a VSD fault condition exists and a compressor that is not running is called to start. The start inhibit will be cleared when the fault condition goes away and the compressor will be permitted to start.

#### **Pre-charge Low DC Bus Voltage (Software) Fault**

The DC Bus voltage must reach at least 50VDC within four seconds and 500VDC within 19 seconds after the pre-charge signal has been asserted. If not, the unit/system will shut down on a fault.

This is an auto-restart safety that will lock out on the 3rd fault in 90 minutes. The fault will be a unit fault for 2 or 3 compressor chillers. The Status display fault message is shown below:

```
UNIT YYYYYYYY
PRECHARGE - LOW DC BUS VOLTAGE
```

The Low DC Bus voltage fault will be a unit fault for 2 and 3 compressor units or a system fault for System 1/3 or 2/4 for 4 compressor units. The reason for this is two inverter power sections with separate DC Bus circuitry for each inverter section is utilized on a 4 compressor unit. One section serves systems 1 and 3 while another serves systems 2 and 4. The Status display fault message is shown below:

```
SYS X YYYYYYYY PRECHARGE - LOW DC BUS VOLT
```

X indicates the system and YYYYYYYY indicates the system is in a “FAULT” condition and will restart when the fault clears or “LOCKOUT” and will not restart until the operator clears the fault using the keypad.

### Pre-charge DC Bus Voltage Imbalance (Software) Fault

The 1/2 DC Bus voltage magnitude must remain within plus or minus 100VDC of the total DC Bus voltage divided by two during the pre-charge interval. If not, the unit/system shall shut down on a fault.

This safety will lock out on the 1st fault. The fault will be a unit fault for 2 or 3 compressor units. The Status display fault message is shown below:

```
UNIT YYYYYYYY
PRECHARGE - DC BUS VOLTAGE IMBALANCE
```

The fault will be a System 1/3 or 2/4 fault for 4 compressor units. Two key presses of the STATUS key are required to show the fault on both systems. The Status display fault message is displayed below:

```
SYS X YYYYYYYY PRECHARGE-BUS VOLT IMBAL
```

X indicates the system and YYYYYYYY indicates the system is in a “LOCKOUT” condition and will not restart until the operator clears the fault using the keypad.

### High DC Bus Voltage (Hardware) Fault

The high DC Bus voltage trip level is determined by hardware on the VSD Logic Board and is designed to trip the unit at 766 plus or minus 30VDC. If the DC Bus exceeds this level, the unit/system will fault and shut down immediately.

This safety is an auto-restart safety that will lock out on the 3rd fault in 90 minutes. The fault will be a unit fault for 2 or 3 compressor units. Two key presses of the STATUS KEY are required to show the fault on both systems. Below is the control panel Status display fault message:

```
UNIT YYYYYYYY
HIGH DC BUS VOLTAGE
```

The fault will be a System 1/3 or 2/4 fault on 4 compressor units. Below is the Status display fault messages for all systems. Two key presses of the STATUS key are required to show the fault on both systems.

```
SYS X YYYYYYYY HIGH DC BUS VOLTAGE
```

X indicates the system and YYYYYYYY indicates the system is in a “FAULT” condition and will restart when the fault clears or “LOCKOUT” and will not restart until the operator clears the fault using the keypad.

### Low DC Bus Voltage (Software) Fault

The low DC Bus voltage trip level is set at 500VDC. If the DC Bus drops below this level the unit/system will fault and immediately shut down.

The low DC Bus voltage cutout is an auto-restart safety that will lock out on the 3rd fault in 90 minutes. The fault is a unit fault for 2 or 3 compressor units. Below is an example of the Status display fault message:

```
UNIT YYYYYYYY
LOW DC BUS VOLTAGE
```

The low DC Bus voltage cutout is a system fault (1/3 or 2/4) on 4 compressor units. Two key presses of the STATUS key are required to show the fault on both systems. Below is a sample Status display system fault message:

```
SYS X YYYYYYYY LOW DC BUS VOLTAGE
```

X indicates the system and YYYYYYYY indicates the system is in a “FAULT” condition and will restart when the fault clears or “LOCKOUT” and will not restart until the operator clears the fault using the keypad.

### DC Bus Voltage Imbalance (Software) Fault

The 1/2 DC Bus voltage magnitude must remain within plus or minus 100VDC of the total DC Bus voltage divided by two. If the 1/2 DC Bus magnitude exceeds the plus or minus 100VDC tolerances, the unit/system will fault and immediately shut down.

This safety will lock out on the 1st fault. The fault will be a unit fault for 2 or 3 compressor units. Below is the Status display fault message:

```
UNIT YYYYYYYY
DC BUS VOLTAGE IMBALANCE
```

The fault will be a System 1/3 or 2/4 fault on 4 compressor units. Two key presses of the STATUS key are required to show the fault on both systems. Below is a sample Status display fault message:

```
SYS X YYYYYYYY DC BUS VOLTAGE IMBALANCE
```

X indicates the system and YYYYYYYY indicates the system is in a “LOCKOUT” condition and will not restart until the operator clears the fault using the keypad.

### High Motor Current (Hardware) Fault

The three output lines to each phase of the compressor motor are monitored via three current transformers within the VSD. The unit's three phases of instantaneous output current will be compared to a predetermined limit, which is contained in hardware. The nominal peak current trip level is 575.5 Amps (554A min., 597A max.). 380VAC, 60Hz and 400VAC, 50Hz nominal peak current trip level is 649.5 Amps (626 Amps min., 674 Amps max.). The variation in trip point is the result of component tolerances on the VSD Logic Board. If the peak current limit is exceeded, the unit will fault and shutdown immediately.

This fault is an auto-restart safety that will lock out system on the 3rd fault in 90 minutes. The fault will be an individual system/compressor fault for all units. Following is a sample Status display fault message:

**SYS X YYYYYYYY HIGH MOTOR CURRENT**

X indicates the system and YYYYYYYY indicates the system is in a "FAULT" condition and will restart or "LOCKOUT" and will not restart until the operator clears the fault using the keypad.

### Motor Current Overload (Software) Fault

The Motor Current Overload will compare the highest of the 3 phases of motor current per compressor to the compressor's 105 % FLA ADJUST (overload) potentiometer setting on the VSD Logic Board. If the current exceeds the setting continuously for 20 seconds, the compressor will trip.

This safety will lock out a system on the 1st fault and shut down with a controlled ramped shutdown. The fault will be an individual system/compressor fault for all systems. A sample Status display fault is shown below:

**SYS X YYYYYYYY MOTOR CURRENT OVERLOAD**

X indicates the system and YYYYYYYY indicates the system is in a "LOCKOUT" condition and will not restart until the operator clears the fault using the keypad.

### Motor Current Overload (Hardware) Fault

The Motor Current Overload will compare the highest of the 3 phases of motor current per compressor to the compressor's overload ADJUST potentiometer setting. If the current exceeds the setting continuously for 30 seconds, all compressors will fault and shut down immediately.

The fault will be a unit fault and will lock out all systems on the first fault. A sample Status display fault is shown below:

**UNIT YYYYYYYY  
MOTOR CURRENT OVERLOAD**

YYYYYYYY indicates the unit is in a "Lockout" condition and will not restart until the operator clears the fault using the keypad.

### IGBT Gate Driver (Hardware) Fault

The unit's phase bank assembly(s) contains one IGBT gate driver control board per compressor. These boards monitor the saturation voltage drop across each of the six IGBT's while gated on. If the IGBT's saturation voltage exceeds the prescribed limit, the gate driver will make the determination that a short circuit is present. This in turn will cause the system to trip. During normal operation, the voltage drop across a saturated IGBT is low. When a short or shoot occurs, the extremely high current causes the voltage across the device to increase. When the electronic hardware on the IGBT Gate Driver Board senses the current rise, it immediately turns off all IGBT's in the module and the system will shut down immediately.

Additionally, if the IGBT's Gate Driver board's power supply voltage falls below the permissible limit, this same fault will be generated.

This is an auto-restart safety that will lock out on the 3rd fault in 90 minutes. The fault will be a system fault for all units. Following is the Status display fault messages for all systems.

**SYS X YYYYYYYY GATE DRIVER**

X indicates the system and YYYYYYYY indicates the system is in a "FAULT" condition and will restart or "LOCKOUT" and will not restart until the operator clears the fault using the keypad.

### High Baseplate Temperature (Software) Fault

Each phase bank assembly contains one liquid cooled heatsink to cool both the inverter power modules and the converter SCR/Diode modules. Each compressor's inverter power module (6 IGBT's and Gate Driver Board) contains an internal temperature sensor (5K ohm at 25 Deg. °C) to monitor the baseplate temperature.

On two compressor chillers, the outputs from System 1 and System 2 sensors are each compared in software to a limit of 218°F. If either sensor exceeds this limit, the unit will fault and shut down with a controlled ramped shutdown.

On 3 compressor chillers, the baseplate temperatures on compressors 1 and 3 are OR'd together and the highest of the two temperatures is compared in software to a limit of 232°F. Compressor #2 will have its individual power module sensor compared in software to a limit of 232°F. If the limit is exceeded by either of the 2 inputs, the unit will fault and shut down with a controlled ramped shutdown.

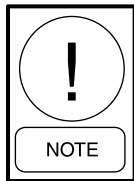

***3 compressor chillers operate at higher baseplate temperature compared to 2 or 4 compressor chillers.***

On 4 compressor chillers, the baseplate temperatures on compressors 1 and 3 are OR'd together and the highest of the two temperatures is compared in software to a limit of 218°F. The baseplate temperatures on compressors 2 and 4 are OR'd together and the highest of the two temperatures compared in software to a limit of 218°F. If the limit is exceeded by either of the 2 inputs, the unit will fault and shut down with a controlled ramped shutdown.

This is an auto-restart safety that will lock out on the 3rd fault in 90 minutes. The fault will be a system fault for all units. Below are the Status display fault messages for all systems.

**SYS X YYYYYYYY HIGH VSD BASEPLATE TEMP**

X indicates the system and YYYYYYYY indicates the system is in a "FAULT" condition and will restart when the fault clears or "LOCKOUT" and will not restart until the operator clears the fault using the keypad.

After a fault, the fan(s) and water pump will remain energized until the inverter power module base plate temperature(s) falls below 165°F. The system will be allowed to restart when the inverter power module base plate temperatures drop below this value.

It is possible for an internal sensor to fail and not sense temperature without causing a high baseplate sensor fault.

### High VSD Internal Ambient Temperature (Software) Fault

The VSD Logic board contains a temperature sensor, which monitors the unit's internal ambient temperature. If the VSD internal ambient temperature rises above the cutout of 158°F, the unit will fault and shut down with a controlled ramped shutdown.

This safety will not cause a lockout. The fault will be a unit fault for all units. Following is the Status display fault message.

**UNIT YYYYYYYY  
HIGH VSD INTERNAL AMBIENT TEMP**

The unit will be allowed to restart when the internal ambient temperature drops 10°F below the cutout.

YYYYYYYY indicates the unit is in a "Fault" condition and will restart when the condition clears.

### Single Phase Input (Hardware) Fault

The VSD's SCR Trigger Control board contains circuitry that checks the three phase mains for the presence of all three-line voltages. If any of the line voltages are not present, the system will immediately shut down on a fault.

This fault will not cause a lockout. The fault will be a unit fault for 2 or 3 compressor units. Below is the Status display fault message.

**UNIT YYYYYYYY  
SINGLE PHASE INPUT VOLTAGE**

The fault will be a system fault 1/3 or 2/4 for 4 compressor units. Two key presses of the STATUS key are required to show the fault on both systems. Below is the fault message for all systems.

**SYS X YYYYYYYY SINGLE PHASE INPUT VOLTS**

X indicates the system and YYYYYYYY indicates the system is "FAULT" and will restart when the single phase condition clears.

### Power Supply (Hardware) Fault

Various DC power supplies which power the VSD Logic Board are monitored via hardware located on the logic board. If any of these power supplies fall outside their allowable limits, the unit will immediately shut down on a fault.

This is an auto-restart safety that will restart after the fault clears and lock out on the 3rd fault in 90 minutes. The fault will be a unit fault for all units. Below is the Status display fault message.

```
UNIT YYYYYYYY
VSD LOGIC BOARD POWER SUPPLY
```

YYYYYYYY indicates the system is in a "FAULT" condition and will restart when the fault clears or "LOCKOUT" and will not restart until the operator clears the fault using the keypad.

### Run Relay (Software) Fault

Upon receipt of either of the two types of run commands (hardware and software) a 5 second timer will commence timing. The hardware run signal comes from the SYS X VSD Run Signal to the VSD Logic Board. The software run signal comes through the comms from the Chiller Control Board. If the missing run signal is not asserted within the 5-second window, the system will fault. In addition, if either run signal is disabled while the VSD is running, the remaining run signal must be disabled within 5 seconds after the VSD is shut down or the system will fault. If running, the unit will fault and shut down with a controlled ramped shutdown.

Control Panel Info - This is an auto-restart safety that will autostart after the 120 second anti-recycle timer times out and will lock out on the 3rd fault in 90 minutes. The fault will be a system fault for 2 compressor units. On 3 and 4 compressor units, the fault is combined as a 1/3 or 2/4 system fault. Below are the fault messages for all systems.

```
SYS X YYYYYYYY VSD RUN RELAY
```

X indicates the system and YYYYYYYY indicates the system is in a "FAULT" condition and will restart when the fault clears or "LOCKOUT" and will not restart until the operator clears the fault using the keypad.

### VSD Logic Board Failure (Software) Fault

Upon receipt of the voltage and frequency commands, the PWM generator will acknowledge receipt of the command. If the system microprocessor does not receive the handshake within 1.5 seconds of issuing the command, the unit will trip. This safety is only active during precharge and during running of a compressor. It is not active when all the compressors are shut down and the precharge is disabled. If the VSD Logic Board Fault occurs while the chiller is running, all systems will immediately shut down on a fault.

This is an auto-restart safety that will auto restart after the 120 second anti-recycle timer times out and lock out on the 3rd fault in 90 minutes. The fault is a unit fault for all units. Following is the fault message.

```
UNIT YYYYYYYY
VSD LOGIC BOARD FAILURE
```

### VSD CT Plug (Hardware) Fault

Jumpers are installed in each CT plug on the VSD Logic Board to feed back signals to indicate if the plugs are installed or not. If either plug is not installed, a low value is read on the digital input and the unit will immediate shutdown on a fault or will not run if off.

This is an auto-restart safety that will restart after the 120 second anti-recycle timer times out and lock out on the 3rd fault in 90 minutes. The fault is a unit fault for all units. Following is the fault message.

```
UNIT YYYYYYYY
VSD CT PLUG FAULT
```

YYYYYYYY indicates the system is in a "FAULT" condition and will restart or "LOCKOUT" and will not restart until the operator clears the fault using the keypad.

### VSD Fault Data

When a fault has occurred, the VSD Logic Board will capture fault data. This data will be stored in the on-board battery backed RAM for safekeeping and transferred to the panel via the communications link as soon as possible.

A fault code will be set for the fault that initiated the system shutdown. This fault will appear as a specific fault in the Status message.

Any faults that occur after the initial fault, which occur within the comms transmission time frame following the inception of the first fault, will be stored and transmitted to the Micro Logic Board together with the first fault data. These faults will appear in the "All Fault" display in the History.

A snapshot of the operating parameters of the VSD is continuously updated in battery-backed memory once every program loop. Upon receipt of a first fault, the snapshot of the operating parameters will be stored in memory and are transmitted to the panel as the fault data.

### Fault Relay/Fault Acknowledge Bit

Control of the Fault Relay is from the VSD Logic Board. The Fault Relay on the VSD will be closed during a non-fault condition.

When a running or pre-charge fault occurs on the VSD, the fault relay will immediately open. The relay will not open for non-running faults that occur.

When the Chiller Control Board sees the VSD fault relay open, it will immediately take a snapshot of system data and save it to the history buffer.

A fault acknowledge bit from the Chiller Control Board is sent to the VSD via comms after receiving valid fault data from the VSD. When the VSD Logic Board receives the fault acknowledge via comms from the panel it will reset (close) the Fault Relay. The fault acknowledge is reset by the Chiller Control Board after the Fault Relay is closed by the VSD Logic Board.

### VSD Fault Compressor Start Inhibit

If a VSD fault condition exists while the compressor is not running or pre-charging, the Chiller Control Board will not try to start the faulted compressor(s). The start inhibit will be automatically cleared when the fault condition goes away.

## UNIT WARNINGS

### Unit Warning Operation

Unit warnings are caused when a condition is present requiring operator intervention to restart the unit. All setpoints, program values, and options should be checked before operating the unit. Warnings are not logged to the history buffer. If a unit warning is in effect, the message will be displayed to the operator when the STATUS key is pressed.

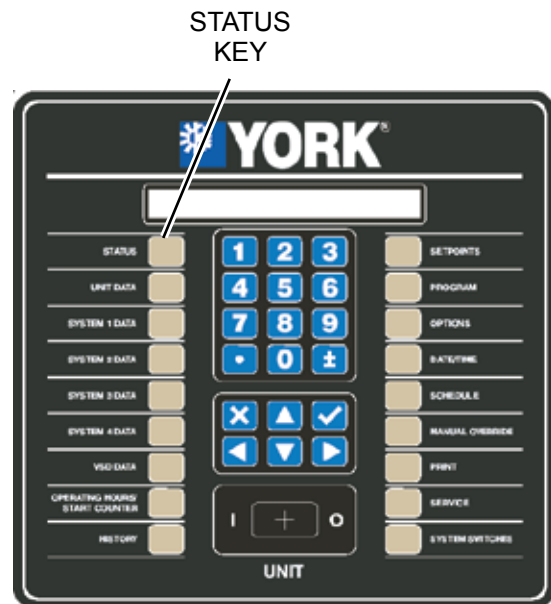

LD10605

### Low Battery Warning

The LOW BATTERY WARNING can only occur at unit power-up. On micropanel power-up, the RTC battery is checked to see if it is still operational. If it is, normal unit operation is allowed. If the battery voltage is determined to be low, the following warning message is displayed indefinitely.

**UNIT WARNING: !! LOW BATTERY !!**  
**CHECK SETPOINTS/PROGRAM/OPTIONS/TIME**

If a low battery condition exists, all programmed setpoints, program values, time, schedule, and history buffers will have been lost. These values will all be reset to their default values, which may not be the desired operating values. Once a bad battery is detected, the unit will be prevented from running until the MANUAL OVERRIDE key is pressed. Once the MANUAL OVERRIDE key is pressed, the anti recycle timers will be set to the programmed default anti recycle time to allow the operator sufficient time to check setpoints, program values, etc.

If a low battery is detected, it should be replaced as soon as possible. The programmed values will all be lost and the unit will be prevented from running on the next power interruption. The RTC/Battery is located on the Chiller Logic Board shown below:

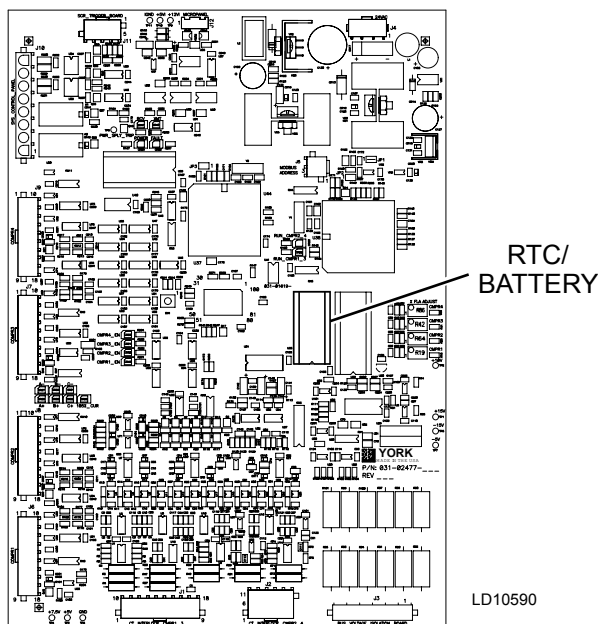

### Invalid Number of Compressors Warning

The INVALID NUMBER OF COMPRESSORS SELECTED Warning will occur after the VSD has been initialized, if no "Number of Compressors Select" jumpers are installed or if more than 1 jumper is installed. The following warning message will be displayed indefinitely.

**UNIT WARNING:  
INVALID NUMBER OF COMPRESSORS SELECTED**

To clear this warning, both the control panel and VSD control voltage must be turned off and the jumpers properly installed in the VSD wiring harness (*see Page 210 for more details on jumper installation*).

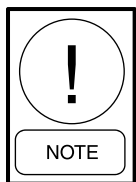

***These jumpers are factory installed in the wire harness plug and should not require changes.***

### Invalid Serial Number Warning

If the INVALID SERIAL NUMBER message appears, immediately contact Johnson Controls Product Technical Support. The appearance of this message may mean the chiller has lost important factory programmed information. The serial number can be entered using the SERVICE key.

**UNIT WARNING: INVALID SERIAL NUMBER  
ENTER UNIT SERIAL NUMBER**

Additionally, when this appears, an Optimized IPLV chiller will only run in Standard IPLV control mode. Optimized IPLV cannot be enabled unless the serial number is programmed into the unit using the special password supplied by Johnson Controls Product Technical Support. Once the password is entered, a second password will be needed to activate the optimized IPLV control (*see Page 292*).

This status message can be bypassed to view additional messages under the STATUS key by pressing the STATUS key repeatedly to scroll through as many as three STATUS messages that could possibly be displayed at any time.

### Optimized Efficiency Disabled

If the OPTIMIZED EFFICIENCY DISABLED message appears, immediately contact Johnson Controls Product Technical Support or Johnson Controls ES Commercial. The appearance of this message means an optimized chiller is programmed for standard control.

**UNIT WARNING: OPTIMIZED EFFICIENCY  
DISABLED - CONTACT YORK REPRESENTATIVE**

Optimized IPLV cannot be enabled unless a special password is entered. Once the password is entered and the option is enabled using the SERVICE key, the message will disappear (*see Page 292*).

This status message can be bypassed to view additional messages under the STATUS key by pressing the STATUS key repeatedly to scroll through as many as three STATUS messages that could possibly be displayed at any time.

## UNIT SAFETIES

### Unit Safety Operation

Unit faults are safeties that cause all running compressors to be shut down, if a safety threshold is exceeded for 3 seconds. Unit faults are recorded in the history buffer along with all data on the unit and system operating conditions. Unit faults are auto reset faults where the unit will be allowed to restart automatically after the fault condition is no longer present. The only exception is any of the VSD related unit faults. If any 3 VSD unit faults occur within 90 minutes, the unit will be locked out on the last fault. A VSD lockout condition requires a manual reset using the system switches. Both system switches must be cycled off and on to clear a VSD unit lockout fault. If a unit safety is in effect, the message will be displayed to the operator when the STATUS key is pressed.

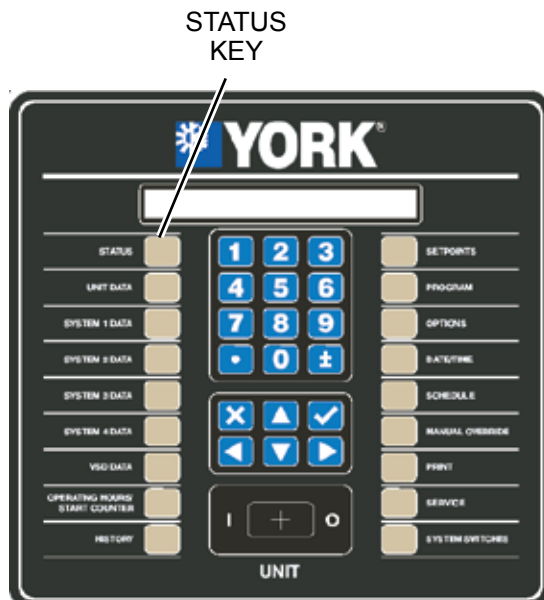

LD10605

In the descriptions of the fault displays that follow, the fault message will show a YYYYYYYY to indicate that a system is in a “FAULT” condition and will restart when the fault clears or LOCKOUT” and will not restart until the operator clears the fault using the keypad.

If a control panel safety occurs after the VSD fault, but before the fault is reset, the control panel fault is an ALL FAULT of the VSD fault, meaning it will be registered as such in the History because it occurred while the VSD was shutting down or while the systems were shut down. All faults do not store operating data at the time of the fault.

If a “VSD” fault occurs during the fault rampdown or while the systems are shut down, the VSD fault will be registered as a new fault. The reason for this is the belief any VSD fault should be registered with a full account of the systems data at the time of the fault.

### High Ambient Temp Fault

If the ambient temperature rises above 130 F, the chiller will shut down with a controlled ramped shutdown. Restart will automatically occur, if demand allows, when temperature falls 2°F below the cutout (128°F). This fault cannot cause a lockout. The fault display message will be present only during the time when the ambient temperature is causing a fault condition. A sample display is shown below:

```
UNIT YYYYYYYY
HIGH AMBIENT TEMP
```

The unit will also be inhibited from starting any time the temperature is above 128°F.

### Low Ambient Temp Fault

If the ambient temperature falls below the programmable Low Ambient Temp Cutout the chiller will shut down with a controlled ramped shutdown. This fault will only occur if the Low Ambient Cutout is “ENABLED” under the OPTIONS key. Restart can occur, if demand allows, when temperature rises 2°F above the cutout. This fault cannot cause a lockout. The fault display message will be present only during the time when the ambient temperature is causing a fault condition. A sample display is shown below:

```
UNIT YYYYYYYY
LOW AMBIENT TEMP
```

The unit is also inhibited from starting any time the temperature is below the cutout plus 2°F.

### Low Leaving Chilled Liquid Temp Fault

The Low Leaving Chilled Liquid Temp Cutout helps to protect the chiller from an evaporator freeze-up should the chilled liquid temp drop below the freeze point. This situation could occur under low flow conditions or if the Micro Panel setpoint values are improperly programmed. Any time the leaving chilled liquid temperature (water or brine) drops below the programmable cutout point, the chiller will fault and shutdown with a controlled ramped shutdown. Restart can occur, if demand allows, when chilled liquid temperature rises 4°F above the cutout. This fault cannot cause a lockout. A sample shutdown message is shown below:

UNIT YYYYYYYY

LOW LEAVING CHILLED LIQUID TEMP

The unit is inhibited from starting any time the chilled liquid temperature is below the cutout plus 4°F.

### VSD Communications Failure Fault

The VSD Communications Failure is to prevent the unit from trying to run, if the Chiller Control Board never initializes communications with the VSD Logic Board. The unit will also shut down with a controlled ramped shutdown if the Chiller Control Board loses communications with the VSD Logic Board while the chiller is operating.

On power-up, the Chiller Microprocessor Board will attempt to initialize communications with the VSD Logic Board. The control panel will request data from the VSD, which includes the number of compressors and the VSD software version. Once these data points have been received by the Chiller Control Board, and have been successfully initialized, the Chiller Control Board will not request them again. If the comms connection fails to occur, the Chiller Control Board will prevent the chiller from operating and a fault message will be displayed.

During normal operation, if the control panel Chiller Control Board receives no valid response to messages for 8 seconds, the unit will shut down all compressors on a Comms fault. The Chiller Control Board will continue to send messages to the VSD while faulted. The unit will be inhibited from starting until communications is established. The fault will automatically reset when the Chiller Control Board receives a valid response from the VSD for a data request. Shown below is an example of a Comms Failure fault message:

UNIT YYYYYYYY

VSD COMMUNICATIONS FAILURE

## SYSTEM SAFETIES (FAULTS)

### System Safety (Fault) Operation

System safeties are faults that cause individual systems to be shut down if a safety threshold is exceeded for 3 seconds. System faults are auto reset faults in that the system will be allowed to restart automatically after the 120 second anti-recycle timer times out. The only exception is after any 3 faults on the same system occur within 90 minutes, that system will be “locked out” on the last fault. The lockout condition requires a manual reset using the system switch. The respective system

switch must be cycled off and on to clear the lockout fault. See TABLE 17 for the programmable limits for many of the cutouts.

When multiple systems are operating and a system fault occurs, the running systems will ramp down and the faulted system will be shut off and the previously operating will restart if required after the fault clears and/or the 120 second anti-recycle timer times out.

In the descriptions of the fault displays that follow, the fault message will show a YYYYYYYY to indicate that a system is in a “FAULT” condition and will restart when the fault clears, or “LOCKOUT” and will not restart until the operator clears the fault using the keypad. If a system safety is in effect, the message will be displayed to the operator when the STATUS key is pressed.

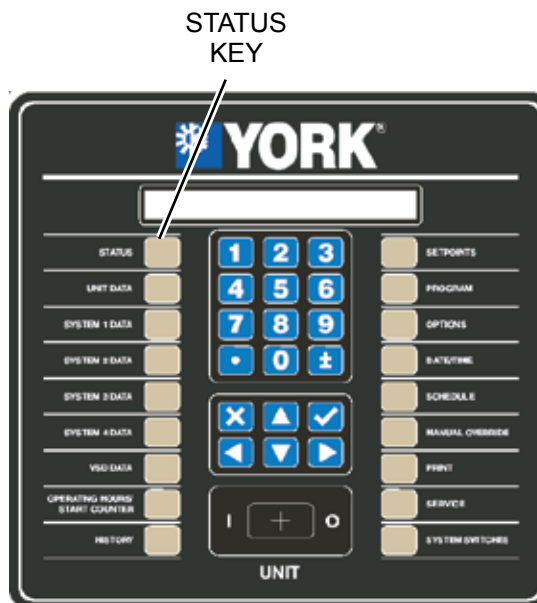

LD10605

In some cases, a control panel fault will occur after a VSD fault, possibly during system shutdown or at some later time. This is known as an “ALL FAULT” and these faults will be recorded as such under the HISTORY information stored at the instant of the primary fault. In some cases, this information may be valuable in troubleshooting the primary fault. An example of the “ALL FAULT” history message is shown on Page 263 under the HISTORY key. When an “ALL FAULT” occurs, associated history information will not be stored. If an additional fault does not occur, the “ALL FAULTS” display will indicate NONE. In cases where a VSD fault occurs during the rampdown of a control panel fault (i.e.: low suction pressure, low water temp, etc.), the VSD fault will be stored as a new

fault with the associated fault information stored at the instant the VSD fault occurred (i.e.: IGBT Gate Drive, Single Phase Input, VSD CT Plug, etc.). The control panel fault that occurred prior to the VSD fault will be stored with the associated complete data related to the fault as a numerically lower numbered history in the history buffers.

### High Discharge Pressure Cutout (Software) Fault

The High Discharge Pressure Cutout is a software fault. A system will fault and shut down with a controlled ramped shutdown on high discharge pressure when the discharge pressure rises above 274 PSIG for 0.5 seconds. The system will be allowed to restart when the discharge pressure falls to 259 PSIG. The system will also be inhibited from starting if the pressure is above 259 PSIG. The fault message for this safety is shown below:

**SYS X YYYYYYYY HIGH DISCHARGE PRESSURE**

X indicates the system and YYYYYYYY indicates the system is in a “FAULT” condition and will restart when the 120 second anti-recycle timer times out, or “LOCKOUT” and will not restart until the operator clears the fault using the keypad.

### High Discharge Pressure Cutout (HPCO) (Hardware) Fault

The mechanical High Pressure Cutout protects the system from experiencing dangerously high discharge pressure. A system will fault and shut down immediately when the mechanical high pressure cutout contacts open. The fault will occur immediately and not wait 3 seconds, which is typical of most system faults. The HPCO is wired in series with the VSD Run Signal and will only be checked by the Chiller Control Board when the system is running. The mechanical cutout opens at 315 plus or minus 8 PSIG and closes at 230 plus or minus 10 PSIG. The Status display fault message for this system is shown below:

**SYS X YYYYYYYY HPCO FAULT**

X indicates the system and YYYYYYYY indicates the system is in a “FAULT” condition and will restart when the 120 second anti-recycle timer times out or “LOCKOUT” and will not restart until the operator clears the fault using the keypad.

### Low Suction Pressure Cutout (Software) Fault

The programmable Low Suction Pressure Cutout is a secondary back-up for the flow switch and protects against operation with low refrigerant charge, which helps protect the chiller from an evaporator freeze-up, should the system attempt to run with a low refrigerant charge. The Status display fault message for this cutout is shown below:

**SYS X YYYYYYYY LOW SUCTION PRESSURE**

X indicates the system and YYYYYYYY indicates the system is in a “FAULT” condition and will restart when the 120 second anti-recycle timer times out or “LOCKOUT” and will not restart until the operator clears the fault using the keypad. Typically, the cutout will be set at 24 PSIG for chilled water applications.

The cutout is ignored for the first 30 seconds of system run time. During the next 3 minutes of run time the cutout point is linearly ramped from 10% of the cutout value up to the programmed cutout point. If at any time during the first 3 minutes of operation the suction pressure falls below the ramped cutout point, the system will shut down with a controlled ramped shutdown.

The cutout pressure during operating periods of 30 seconds to 210 seconds is ramped and can be calculated by:

$$\text{Cutout} = \frac{(\text{Programmed Cutout} \times \text{Run Time}) - 1.2 \text{ PSIG}}{200}$$

After the first 3 minutes and 30 seconds of run time, if the suction pressure falls below the cutout as a result of a transient in the system, a transient timer is set at 30 seconds and a linearly ramped cutout is set starting at 10% of the programmed cutout. If over the next 30 seconds, the suction pressure does not stay above the ramped cutout, which ramps between 10% of the cutout and the programmed cutout over the 30 second period, the system will fault on low suction pressure.

### Low Motor Current Cutout Fault

The Motor Current Cutout shuts the system down with a controlled ramped shutdown when the microprocessor detects the absence of motor current (less than 10% FLA), usually indicating that a compressor is not running. This safety is ignored for the first 10 seconds of operation.

The status display fault message for this safety is shown below:

**SYS X YYYYYYYY LOW MOTOR CURRENT**

X indicates the system and YYYYYYYY indicates the system is in a “FAULT” condition and will restart when the 120 second anti-recycle timer times out or “LOCK-OUT” and will not restart until the operator clears the fault using the keypad.

### High Differential Oil Pressure Cutout Fault

The High Differential Oil Pressure Cutout protects the compressor from low oil flow and insufficient lubrication, possibly from a dirty oil filter. A system will fault and shut down with a controlled ramped shutdown when its Discharge to Oil Differential Pressure rises above the cutout of 65 PSID. This safety is ignored for the first 90 seconds of run time. This safety measures the pressure differential between discharge and oil pressure, which is the pressure drop across the oil filter. The Status display fault message for this safety is shown below:

**SYS X YYYYYYYY HIGH DIFF OIL PRESSURE**

X indicates the system and YYYYYYYY indicates the system is in a “FAULT” condition and will restart when the 120 second anti-recycle timer times out or “LOCK-OUT” and will not restart until the operator clears the fault using the keypad.

### Low Differential Oil Pressure Cutout Fault

The Low Differential Oil Pressure Cutout protects the compressor from low oil flow and insufficient lubrication. A system will fault and shut down with a controlled ramped shutdown when it’s differential between oil and suction pressure falls below the cutout. This safety assures that the compressor is pumping sufficiently to push oil through the oil cooling circuit and through the internal compressor lubrication system. The Status display fault message for this safety is shown below:

**SYS X YYYYYYYY LOW DIFF OIL PRESSURE**

X indicates the system and YYYYYYYY indicates the system is in a “FAULT” condition and will restart when the 120 second anti-recycle timer times out or “LOCK-OUT” and will not restart until the operator clears the fault using the keypad.

The safety is ignored for the first 60 seconds of run time. After the first 60 seconds of operation, the cut-out is linearly ramped from 0 PSID to 30 PSID in 5 to 10 minutes based on ambient temperature. *See TABLE 13 for the ramp times for the given ambient temperatures.*

**TABLE 13 - LOW DIFFERENTIAL OIL PRESSURE CUTOUT**

AMBIENT TEMPERATURE	RAMP TIME
> 50°F	5 Minutes
> 45°F	6 Minutes
> 40°F	7 Minutes
> 35°F	8 Minutes
> 30°F	9 Minutes
>=30°F	10 Minutes

A 30 second safety bypass below 50 Hertz is employed during rampdown. The bypass is primarily needed under conditions where another compressor is being brought on and the running compressor is being ramped down to 5 Hertz to add the additional compressor due to load requirements. Under these conditions, the slow speed of the running compressor(s) causes the oil differential to become very low, especially if the water temperature is high and the suction pressure is high. The bypass assures the compressor(s) will not trip on a nuisance low oil differential fault.

### High Discharge Temperature Cutout Fault

The High Discharge Temperature Cutout protects the motor and compressor from overheating. A system will fault and shut down with a controlled ramped shutdown when its Discharge Temperature rises above 250°F. A system will also be inhibited from starting if the discharge temperature is above 200°F. The Status display fault message for this safety is shown below:

**SYS X YYYYYYYY HIGH DSCHARGE TEMP**

X indicates the system and YYYYYYYY indicates the system is in a “FAULT” condition and will restart when the 120 second anti-recycle timer times out or “LOCK-OUT” and will not restart until the operator clears the fault using the keypad.

### High Oil Temperature Cutout Fault

The High Oil Temperature Cutout protects the compressor from insufficient lubrication. A system will fault and shut down with a controlled ramped shut-

down when its oil temperature rises above 225°F. The system will be inhibited from starting if the oil temperature is above 175°F. The Status display fault message for this safety is shown below:

**SYS X YYYYYYYY HIGH OIL TEMP**

X indicates the system and YYYYYYYY indicates the system is in a “FAULT” condition and will restart when the fault clears or “LOCKOUT” and will not restart until the operator clears the fault using the keypad.

### Low Suction Superheat Cutout Fault

The Low Suction Superheat Cutout helps protect the compressor from liquid floodback due to low suction superheat. This safety is ignored for the first 30 seconds of compressor operation. Low suction superheat will fault a system when any one of the following conditions occur:

- After the first 30 seconds of run time, if the suction superheat falls below 2.0°F, the discharge superheat is less than 15°F, and the run time is less than 5 minutes, the superheat safety will be ignored for the next 30 seconds followed by setting the superheat cutout to 0°F and linearly ramping it up to 2.0°F over the next 60 seconds. If at any time during these 60 seconds the suction superheat falls below the ramped cutout, the system will fault and shut down with a controlled ramped shutdown.
- If the suction superheat less than 2°F, the discharge superheat less than 15°F for 10 seconds, and the run time is equal to or more than 5 minutes, the system will fault and shutdown with a controlled ramped shutdown.
- If the suction superheat less than 0.5°F and discharge superheat is more than 15°F for 60 seconds and run time equal to or more than 5 minutes, the system will fault and shutdown with a controlled ramped shutdown.
- If suction superheat less than 5°F for 10 minutes, the system will fault and shutdown with a controlled ramped shutdown.

The Status display fault message for this safety is shown below:

**SYS X YYYYYYYY LOW SUCTION SUPERHEAT**

X indicates the system and YYYYYYYY indicates the system is “FAULT” and will restart after the 120 second anti-recycle timer times out or “LOCKOUT” and will not restart until the operator clears the fault.

### Low Discharge Superheat Cutout Fault

The Low Discharge Superheat Cutout helps protect the compressor primarily from liquid floodback through the economizer line due to a high flash tank level. It also provides protection from liquid floodback through the suction line in conjunction with the low superheat safety. This safety is ignored for the first 5 minutes of compressor operation.

After the first 5 minutes of run time, if the discharge superheat falls below 10.0°F for 5 minutes, the system will fault and shut down with a controlled ramped shutdown.

The Status display fault message for this safety is shown below:

**SYS X YYYYYYYY LOW DISCHARGE SUPERHEAT**

X indicates the system and YYYYYYYY indicates the system is in a “FAULT” condition and will restart when the 120 second anti-recycle timer times out or “LOCKOUT” and will not restart until the operator clears the fault using the keypad.

### Sensor Failure Cutout Fault

The Sensor Failure Cutout prevents the system from running when a critical sensor (transducer, level sensor, or motor winding temp sensor) is not functioning properly and reading out of range. This safety is checked at start-up and will prevent the system from running if one of the sensors has failed.

The sensor failure safety will also fault and shutdown a system while in operation, if a safety threshold is exceeded or a sensor reads out of range (high or low). Following is the Status display fault message.

**SYS X YYYYYYYY SENSOR FAILURE:**

**ZZZZZZZZZZZZ**

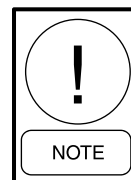

*X indicates the specific system. YYYYYYYY will either indicate the system is in a “FAULT” condition and will restart when the fault clears, or “LOCKOUT” after 3 faults and will not restart until the operator clears the fault using the keypad.*

ZZZZZZZZZZ indicates the failed sensor below:

- SUCT PRESS
- OIL PRESS
- DSCH PRESS
- LEVEL SENSOR
- MOTOR TEMP X \*

\*The Unit Setup Mode allows a specific motor temperature sensor to be ignored, if it fails.

The start inhibit thresholds for each sensor are shown in TABLE 14.

**TABLE 14 - START INHIBIT SENSOR THRESHOLDS**

SENSOR	LOW THRESHOLD	HIGH THRESHOLD
SUCTION TRANSDUCER	0.3VDC	4.7VDC
OIL TRANSDUCER	0.3VDC	4.7VDC
DISCHARGE TRANSDUCER	0.3VDC	4.7VDC
LEVEL SENSOR	3.0ma	21.0ma
MOTOR TEMP. SENSOR	0°F	240°F

**High Motor Temperature Cutout Fault**

The High Motor Temperature Cutout prevents a compressor from running when its motor temperature is too high. A system will fault and shut down when any compressor motor temperature sensor rises above 250°F. The system will be inhibited from starting if its motor temperatures sensors indicate temperatures above 240°F. If any single temperature sensor is being ignored under the Unit Set-up Mode, that sensor will not be utilized when evaluating motor temperature.

Below is a sample Status display fault message:

**SYS X YYYYYYYY HIGH MOTOR TEMP**

X indicates the system and YYYYYYYY indicates the system is in a “FAULT” condition and will restart when the fault clears or “LOCKOUT” and will not restart until the operator clears the fault using the keypad.

**High Flash Tank Level Cutout Fault**

The Flash tank level Cutout prevents the system from running when the liquid level in the flash tank is too high. The safety will be ignored for the first 15 seconds of system operation.

A fault will occur if the tank level is greater than 85% for 10 seconds.

Below is a sample Status fault display fault message:

**SYS X YYYYYYYY HIGH FLASH TANK LEVEL**

X indicates the system and YYYYYYYY indicates the system is in a “FAULT” condition and will restart when the 120 second anti-recycle timer times out or “LOCK-OUT” and will not restart until the operator clears the fault using the keypad.

**System Control Voltage Cutout Fault**

The System Control Voltage Cutout alerts the operator the 115VAC Control voltage to one of the systems is missing. This could be due to a system fuse that has been removed or is blown. The affected system will fault and shut down immediately when the 115VAC supply is lost.

The safety will “not” shut down a system if the UNIT switch is OFF, which electrically removes the 115VAC to “all” systems. The safety is only used to indicate a situation where a single system is missing the 115VAC. The safety will not cause a lockout and the system fault will reset when power is returned. A sample message is shown below:

**SYS X YYYYYYYY CONTROL VOLTAGE**

X indicates the system and YYYYYYYY indicates the system is in a “FAULT” condition and will restart when the fault clears or “LOCKOUT” and will not restart until the operator clears the fault using the keypad.

## STATUS KEY

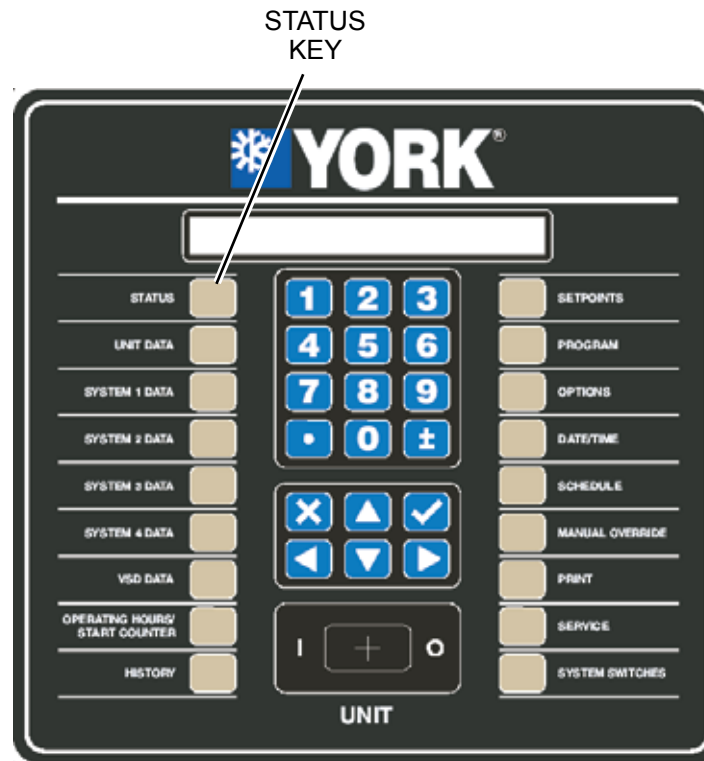

LD10605

8

### Status Key Operation

The STATUS key displays the current chiller or system operational status. The messages displayed include running status, cooling demand, system faults, unit faults, VSD faults, unit warnings, external device status, load limiting, anti-recycle timer, status of unit/system switches, and a number of other messages. Pressing the STATUS key will enable the operator to view the current status of the chiller. The display will show one message relating to the “highest priority” information as determined by the microprocessor. The STATUS key must be pressed twice to view both System 1/2 and System 3/4 data. There are three types of status data, which may appear on the display:

- General Status messages
- Unit Safeties
- System Safeties.

When power is first applied to the control panel, the following message displaying YORK International Corporation, the EPROM version, date, and time will be displayed for 2 seconds, followed by the appropriate general status message:

**(C)2004 YORK INTERNATIONAL CORPORATION**  
**C.XXX.XX.XX 18-SEPT-2005 12:45: AM**

Unit status messages occupy 2 lines of the Status message display. If no unit status message applies, individual status messages for each system will be displayed. On 3 and 4 compressor units, the STATUS key must be pressed twice to display the status of all systems.

Any time the STATUS key is pressed or after the EPROM message disappears at power-up, a status display indicating chiller or system status will appear.

Multiple STATUS messages may appear and can be viewed by pressing the STATUS key repeatedly to allow scrolling through as many as three STATUS messages, that could possibly be displayed at any time on a 2 compressor chiller or 4 messages that could be displayed on a 3 or 4 compressor chiller.

Examples of the typical Status messages are shown in the next topic

## General Status Messages

### UNIT STATUS MANUAL OVERRIDE

This message indicates the chiller is operating in MANUAL OVERRIDE mode. This message is a priority message and cannot be overridden by any other STATUS message. When in Manual Override, no other status message will ever be present.

### UNIT STATUS UNIT SWITCH OFF SHUTDOWN

This message indicates the UNIT SWITCH is in the off position and not allowing the unit to run.

### UNIT STATUS DAILY SCHEDULE SHUTDOWN

This message indicates that either the daily or holiday schedule programmed is keeping the chiller from running.

### UNIT STATUS REMOTE CONTROLLED SHUTDOWN

This message indicates that either an ISN or RCC has turned the chiller off and is not allowing it to run.

### UNIT STATUS FLOW SWITCH SHUTDOWN

This message indicates the flow switch is not allowing the chiller to run. There is a 1 second delay on this safety to assure the flow switch did not momentarily open.

### UNIT STATUS VSD COOLING SHUTDOWN

This message indicates the chiller is shutdown, but running all the condenser fans, VSD glycol pump, and VSD fan in an effort to bring the internal VSD ambient temperature down to an acceptable level before allowing the chiller to start.

### SYS X REMOTE RUN CONTACT IS OPEN

This message indicates the remote start/stop contact between 2-15 or 2-16 of the 1TB terminal block is open. There is a 1 second delay on this safety to assure the remote contacts did not momentarily open.

### SYS X SYSTEM SWITCH IS OFF

This message indicates the system switch (software via keypad) is turned off. The system will not be allowed to run until the system switch is turned ON via the keypad.

### SYS X NOT RUNNING

This message indicates the system is not running because the chilled liquid is below the setpoint or the micro has not loaded the lead system far enough into the loading sequence to bring the lag system on. This message will be displayed on the lag system until the loading sequence is ready for the lag system to start.

### SYS X COOLING DEMAND SHUTDOWN

This message is only displayed in the Normal Shutdown History display to indicate a capacity control shutdown.

### SYS X COMPRESSOR RUNNING

This message indicates the system is running as a result of cooling demand.

### SYS X SHUTTING DOWN

The compressor shutting down message indicates the respective system is ramping down in speed prior to shutting off. This message is displayed after the software run signal is disabled until the VSD notifies the Chiller Control Board the compressor is no longer running.

### SYS X ANTI-RECYCLE TIMER = XXX SEC

This message indicates the amount of time left on the respective system anti-recycle timer and the system is unable to start until the timer times out.

### SYS X DISCHARGE PRESSURE LIMITING

The Discharge Pressure Limiting message indicates the discharge pressure load limit or discharge pressure unloading is in effect.

**SYS X SUCTION PRESSURE LIMITING**

The Suction Pressure Limiting message indicates the suction pressure load limit or suction pressure unloading is in effect.

**SYS X MOTOR TEMP LIMITING**

The Motor Temp Limiting message indicates the motor temp load limit or motor temp unloading is in effect.

**SYS X MOTOR CURRENT LIMITING**

The motor current limiting message indicates the motor current load limit or motor current unloading is in effect.

**SYS X PULLDOWN MOTOR CURRENT LIMITING**

The pulldown motor current limiting message indicates the pulldown motor current load limit or pulldown motor current unloading is in effect based on the programmed setpoint.

**SYS X ISN CURRENT LIMITING**

The ISN Current Limiting message indicates the motor current load limit or motor current unloading is in effect through the use of the YORKTalk setpoint.

**SYS X REMOTE MOTOR CURRENT LIMITING**

The Remote Motor Current Limiting message indicates the motor current load limit or motor current unloading is in effect through the use of the remote setpoint offset. The setpoint may be offset using a remote voltage or a current signal. The remote current limit must be activated for this function to operate.

**SYS X VSD BASEPLATE TEMP LIMITING**

The VSD Baseplate Temp Limiting message indicates the VSD Baseplate temp is high and load limit or unloading is in effect.

**SYS X VSD INTERNAL AMBIENT TEMP LIMITING**

The VSD Internal Ambient Temp Limiting message indicates the VSD internal ambient temp is high and load limit or unloading is in effect.

**SYS X SOUND LIMITING**

The sound limiting message indicates the sound load limit is in effect based on the locally programmed sound limit from the keypad. The sound limit must be activated for this function to operate.

**SYS X ISN SOUND LIMITING**

The ISN sound limiting message indicates the sound load limit is in effect based on the ISN transmitted sound limit setpoint. The sound limit must be activated for this function to operate.

**SYS X REMOTE SOUND LIMITING**

The Remote sound limiting message indicates the sound load limit is in effect based on the Remote controlled sound limit setpoint. The setpoint may be offset using a remote voltage or current signal. The sound limit option must be activated for this function to operate.

**Unit Safety (Fault) Status Messages**

A complete listing of the unit safeties and the corresponding status messages is provided on Page 245.

**System Safety (Fault) Status Messages**

A complete listing of the system safeties and the corresponding status messages is provided on Page 246.

**VSD Safety (Fault) Status Messages**

A complete listing of VSD safeties and the corresponding status messages is provided on Page 237.

**Unit Warning Messages**

A complete listing of the unit warnings and the corresponding status messages is provided on Page 243.

## UNIT DATA KEY

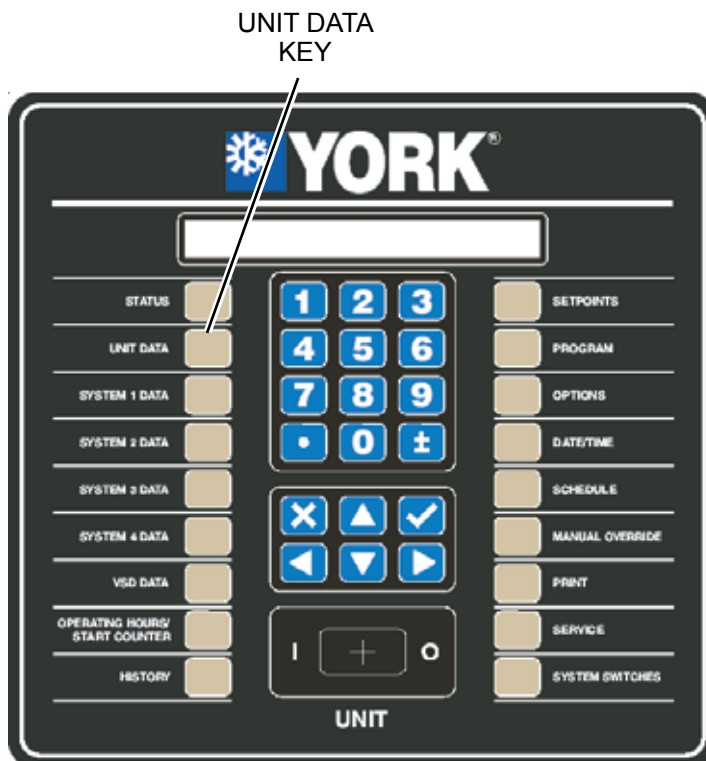

LD10605

**General**

The UNIT DATA key provides the user with displays of unit temperatures, and unit related data. Displays can be selected by repeatedly pressing the UNIT DATA key or the ▲ or ▼ Arrow Keys.

**Unit Data Key Operation**

The first key press displays Evaporator Leaving and Return Chilled Liquid Temps.

**UNIT CHILLED LIQUID LEAVING = XXX.X °F**  
**ENTERING = XXX.X °F**

The next key press of the UNIT DATA key or the ▼ (ARROW) key displays the ambient air temperature.

**UNIT**  
**OUTSIDE AMBIENT AIR TEMP = XXX.X °F**

The next key press will display the time remaining on the load and unload timers.

**UNIT**  
**LOAD TIMER = XXX SEC**  
**UNLOAD TIMER = XXX SEC**

The next key press displays the error in temperature between the actual leaving chilled liquid temperature and the setpoint temperature. The display also shows the rate of change of the chilled liquid temperature.

**UNIT**  
**TEMP ERROR = XXX.X °F**  
**RATE = XXX.X °F/M**

The next key press displays the system designated as the lead system and the Flow Switch status (ON or OFF).

**UNIT**  
**LEAD SYSTEM NUMBER = X**  
**FLOW SWITCH = XXX**

The next key press displays the status of the evaporator pump and heater, where XXX is either ON or OFF.

**UNIT**  
**EVAP PUMP RUN = XXX**  
**EVAP HEATER = XXX**

The next key press displays the status of Active Remote Control.

**UNIT ACTIVE REMOTE CONTROL = XXXXXX**  
**TYPE: RCC ISN CURR TEMP SOUND**

XXXXXX is either ACTIVE or NONE.

If no remote keys are active, the items on the second line are all blanked out. Any remote items that are active will be displayed, while the inactive items will be blanked out.

The types of remote control are listed below:

- NONE - No remote control is actively controlling the chiller; however, remote monitoring by a remote device may still be active.

- RCC - A Remote Control Center is providing remote control. The chiller is in remote mode.
- ISN - YorkTalk via ISN. The chiller in remote mode.
- CURR - Remote Current Limiting is enabled.
- TEMP - Remote Temperature Reset is enabled.
- SOUND - Remote Sound Limiting is enabled.

The next key press displays the sound limit values as set under the PROGRAM key by the Local, ISN, and the Remote Sound Limit Inputs. Any sound limits that are inactive will display XXX instead of a numeric value.

**UNIT SOUND LIMIT**                      **LOCAL = XXX %**  
**ISN = XXX**                                **REMOTE = XXX %**

## SYSTEM DATA KEYS 1 THROUGH 4

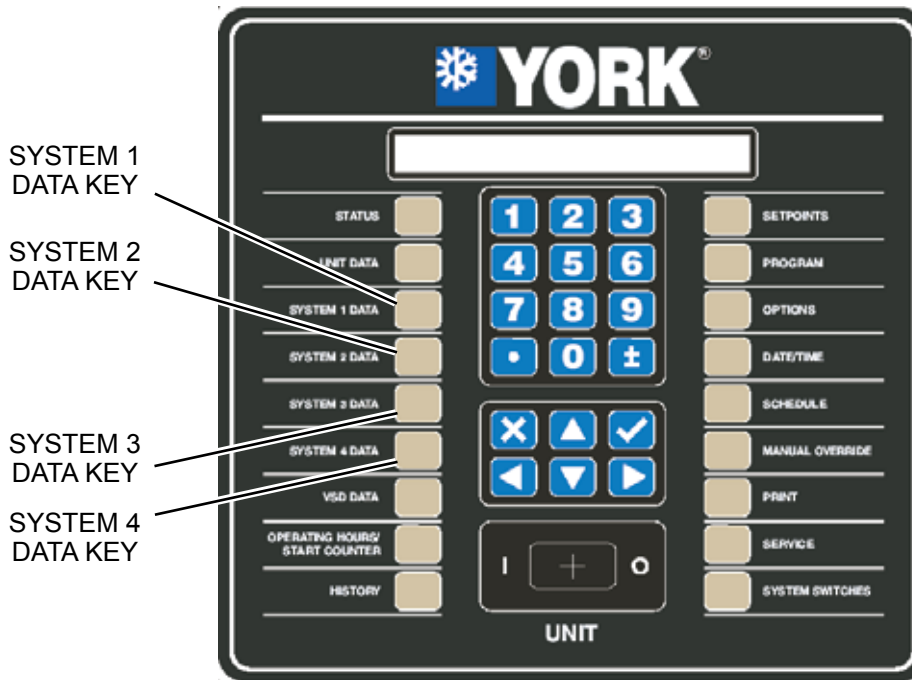

LD10605

### General

The data keys provide the user with many displays of individual system temperatures, pressures, and other operating data. These keys have multiple displays, which can be seen by repeatedly pressing the SYSTEM DATA or the ▲ or ▼ (ARROW) keys. An explanation of each key and its messages is provided below.

### System 1 Data Key Operation

The SYSTEM 1 DATA key provides the user with access to System 1 operating parameters. The following is a list of the data in the order in which it appears.

The first key press of the SYSTEM X DATA key displays all of the measured system pressures (oil, suction, and discharge).

**SYS 1 PRESSURES      OIL = XXXX PSIG**  
**SUCTION = XXXX    DISCHARGE = XXXX PSIG**

The second key press of the SYSTEM DATA key or the ▼ (DOWN ARROW) key displays all of the measured system temperatures (oil, suction, and discharge).

**SYS 1 TEMPERATURES      OIL = XXX.X °F**  
**SUCTION = XXX.X    DISCHARGE = XXX.X °F**

The next key press displays the suction temperature and all of the calculated suction temperatures (saturated suction and system superheat).

**SYS 1 SUCTION      TEMP = XXX.X °F**  
**SUPERHEAT = XXX.X    SAT TEMP = XXX.X °F**

The next key press displays the discharge temperature and all of the calculated discharge temperatures (saturated discharge and discharge superheat).

**SYS 1 DISCHARGE      TEMP = XXX.X °F**  
**SUPERHEAT = XXX.X    SAT TEMP = XXX.X °F**

The next key press displays the System 1 motor thermistor temperatures.

**SYS 1 MOTOR TEMPS      T1 = XXX.X °F**  
**T2 = XXX.X °F      T3 = XXX.X °F**

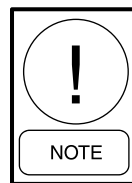

*If any motor temp sensor is being ignored, (selectable under Unit Set-up Mode), that sensor's value will be displayed as XXXXX.*

The next key press indicates the % of compressor loading and status of the economizer solenoid as determined by the operating frequency.

**SYS 1 COMPRESSOR SPEED = XXX.X %  
ECONOMIZER SOLENOID = XXX**

XXX indicates whether the economizer solenoid is either ON or OFF.

The next key press displays the liquid level in the flash tank and an indicator of the % the Flash Tank Feed Valve is open.

**SYS 1 FLASH TANK LEVEL = XXX.X %  
FEED VALVE PERCENT OPEN = XXX.X %**

The next key press displays the system suction superheat and an indicator of the % the Flash Tank Drain Valve is open.

**SYS 1 SUCTION SUPERHEAT = XXX.X °F  
DRAIN VALVE PERCENT OPEN = XXX.X %**

The next key press displays the system fan stage and the status of the compressor heater.

**SYS 1 CONDENSER FANS ON = X  
COMPRESSOR HEATER = XXX**

X equals the number of fans ON. XXX indicates either the heater is ON or OFF.

The next key press displays the system run time in days, hours, minutes, and seconds.

**SYS 1 RUN TIME  
XX DAYS XX HOURS XX MINUTES XX SECONDS**

The next key press displays the status of several system signals.

**SYS 1 RUN SIGNALS RELAY = XXX  
RUN PERM = XXX SOFTWARE = XXX**

XXX indicates either ON or OFF.

### System 2 through 4 Data Key Operation

These keys function the same as the SYSTEM 1 DATA key except that it displays data for System 2 through 4.

On a 2 compressor system, the SYSTEM 3 and SYSTEM 4 data keys will display the following messages:

**SYS 3 DATA NOT AVAILABLE**

**SYS 4 DATA NOT AVAILABLE**

## Sensor Displays

TABLE 15 lists all the sensors attached to the control board associated with system data keys. The minimum and maximum values displayed on the micro display are provided.

If values exceed the limits in the table, a < (less than) or > (more than) sign will be display along with the minimum or maximum value.

**TABLE 15 - SENSOR MIN/MAX OUTPUTS**

SENSOR	TYPE	MIN.	MAX.
Suction Pressure	Transducer	0.0 PSIG	125.0 PSIG
Oil Pressure	Transducer	0.0 PSIG	275.0 PSIG
Discharge Pressure	Transducer	0.0 PSIG	275.0 PSIG
Flash Tank Level	Capacitance	0.0%	100 %
Leaving Chilled Liquid Temp.	3Kohm Thermistor	-19.1°F	110.2°F
Return Chilled Liquid Temp.	3Kohm Thermistor	-19.1°F	110.2°F
Ambient Air Temp.	10Kohm Thermistor	-4.6°F	137.9°F
Suction Temp.	3Kohm Thermistor	-4.1°F	132.8°F
Oil Temp.	50Kohm Thermistor	40.3°F	302.6°F
Discharge Temp.	50Kohm Thermistor	40.3°F	302.6°F
Compressor Motor Temp.	10Kohm Thermistor	-30.0°F	302.0°F
Remote Temp. Reset	4-20mA/2-10VDC	0 %	100 %
	0-20mA/0-10VDC		
Remote Current Limit	4-20mA/2-10VDC	0 %	100 %
	0-20mA/0-10VDC		
Remote Sound Limit	4-20mA/2-10VDC	0 %	100 %
	0-20mA/0-10VDC		



The next key press displays the current limit values set locally on the panel under the PROGRAM key, remotely by an ISN, and remotely by the Current Limit input. Any current limits that are inactive will display “XXX” instead of a numeric value.

**VSD CURRENT LIMIT LOCAL = XXX %FLA**  
**ISN = XXX REMOTE = XXX %FLA**

The next key press displays DC Bus voltage for 2 and 3 compressor units. On 4 compressor units, the 2nd message will apply, since two DC Bus voltages are present (Systems 1/3 and 2/4).

**VSD DC BUS VOLTAGE = XXX VDC**

**VSD DC BUS VOLTAGES BUS 1 = XXX VDC**  
**BUS 2 = XXX VDC**

The next key press displays the Control Panel/VSD Internal Ambient Temperature and VSD Cooling Pump/Fan Status. YYY will indicate ON or OFF.

**VSD INTERNAL AMBIENT TEMP = XXX.X °F**  
**COOLING SYSTEM STATUS = YYY**

The next key press displays the IGBT highest baseplate temperature for 2 and 3 compressor units. 4 compressor units display temperatures for Systems 1/3 (T1) and Systems 2/4 (T2).

**VSD IGBT BASEPLATE TEMPS T1 = XXX °F**  
**T2 = XXX °F**

The next key press displays the state of the Precharge signal, where XXX is either ON or OFF. The first display is for 2 and 3 compressor units, the second display shown is for 4 compressor units where Precharge 1 is for compressors 1 and 3 DC Bus and Precharge 2 is for compressors 2 and 4 DC Bus.

**VSD PRECHARGE SIGNAL = XXX**

**VSD PRECHARGE 1 SIGNAL = XXX**  
**VSD PRECHARGE 2 SIGNAL = XXX**

The next key press displays the setting of the VSD’s 105% FLA overload potentiometer for Compressor #1 and 2. The settings are determined by the adjustment of the overload potentiometers on the VSD Logic Board. These pots are factory set and should not require changing unless the circuit board is replaced. See *TABLE 35 for factory settings*.

**VSD COMP 1 MOTOR OVERLOAD = XXX AMPS**  
**COMP 2 MOTOR OVERLOAD = XXX AMPS**

The next key press displays the setting of the VSD’s 105% FLA potentiometer for Compressor #3 and #4 (3 and 4 compressor units only). The second line will be blanked out on 3 compressor units.

**VSD COMP 3 MOTOR OVERLOAD = XXX AMPS**  
**COMP 4 MOTOR OVERLOAD = XXX AMPS**

## OPERATING HOURS / START COUNTER KEY

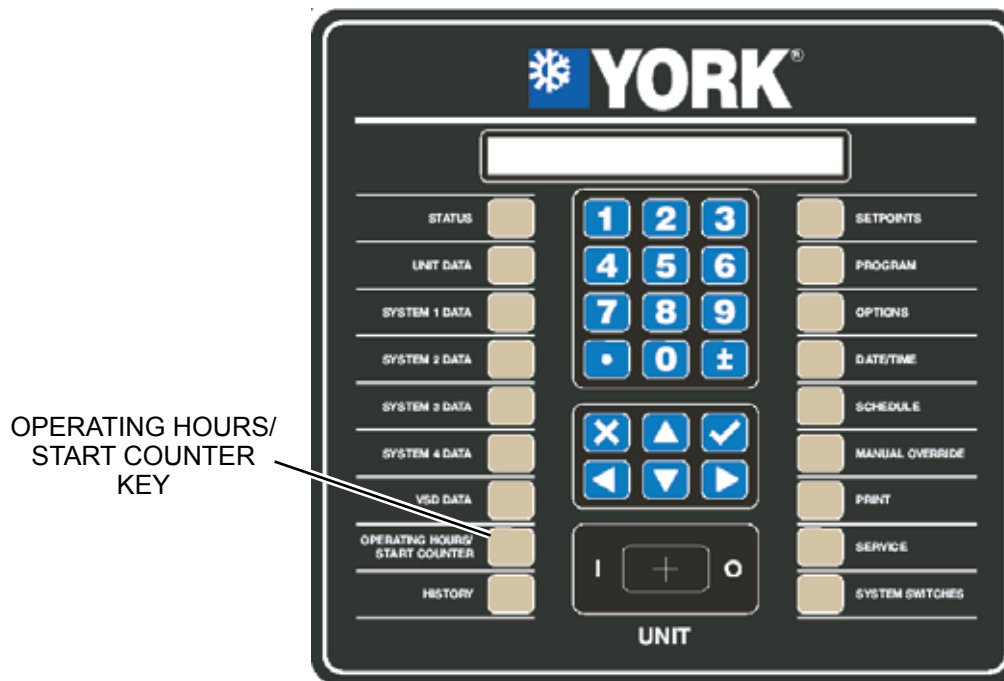

OPERATING HOURS/  
START COUNTER  
KEY

8

LD10605

Compressor operating hours and compressor starts are displayed with a single key press. The maximum value for both hours and starts is 99,999, at which point they will roll over to 0. A single display is available under this key and is displayed below. On 2 and 3 compressor units, the data and compressor designators for compressors not present are blanked out.

**HOURS 1=XXXXX, 2=XXXXX, 3=XXXXX, 4=XXXXX**  
**START 1=XXXXX, 2=XXXXX, 3=XXXXX, 4=XXXXX**

## HISTORY KEY

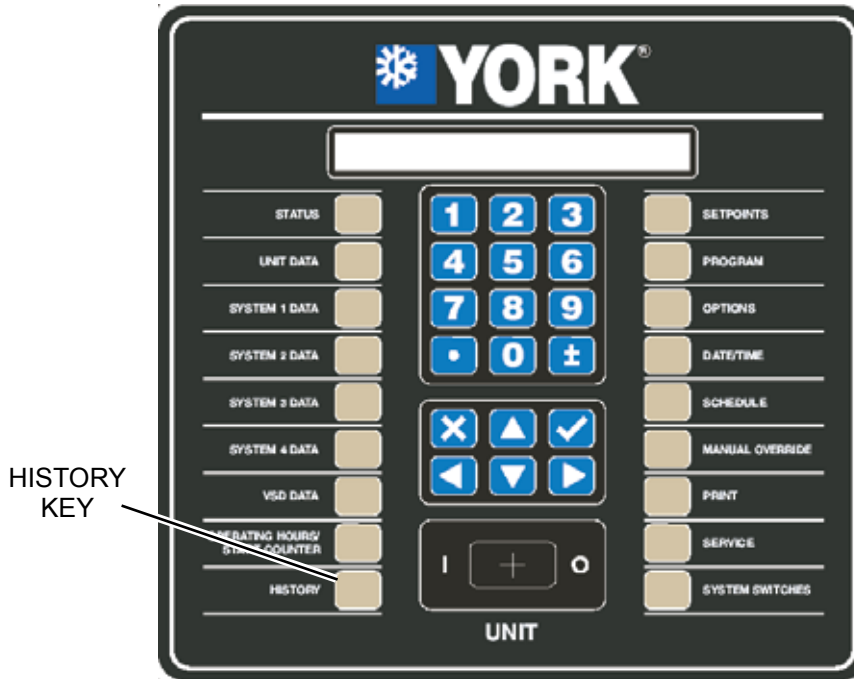

LD10605

### History Key Operation

The HISTORY key provides the user access to many unit and system operating parameters captured at the instant a unit or system safety (fault) shutdown occurs. The history buffer will also capture system data at the time of normal shutdowns such as cycling shutdowns. When the HISTORY key is pressed the following screen is displayed:



The ◀ and ▶ (ARROW) keys allow choosing between NORMAL SHUTDOWNS and FAULT SHUTDOWNS. “Fault” shutdowns provide information on safety shutdowns, while “Normal” shutdowns provide chiller cycling information on temperature (demand), cycling, remote, system switch, etc., shutdowns that are non-safety related shutdowns. Once the selection is made, the ✓ (ENTER) key must be pressed to enter the selection.

### Normal Shutdowns History

If the NORMAL SHUTDOWNS History is selected, the following screen will be displayed:



XX is the normal shutdown number. The display will provide date and time of the shutdown and the reason for the cycling shutdown (YYY....).

The operator can view any of the stored 20 single display normal shutdown history buffers. History buffer number 1 provides the most recent shutdown information and buffer number 20 is the oldest safety shutdown information saved. The ◀ and ▶ (ARROW) keys allow scrolling between each of the history buffers. The ▶ (ARROW) key scrolls to the next normal history shutdown and the ◀ (ARROW) key scrolls to the previous normal history shutdown.

The following display will typically be displayed on a normal shutdown due to shutdown on lack of cooling demand.



### Fault Shutdowns History

If the FAULT SHUTDOWNS History is selected, the following screen will be displayed:

```

FAULT HIST XX 18-JUN-2004 10:34:58 AM
XXXXXXXXXXXXXXXXXXXXXXXXXXXXXXXXXXXXXXXXXXXX
    
```

XX is the FAULT HISTORY shutdown number. The display will provide the date, time, and a description of the specific type of fault that occurred (YYY....).

The operator can view any of the stored 10 fault history buffers. History buffer number 1 provides the most recent safety shutdown information and buffer number 10 is the oldest safety shutdown information saved. The ◀ and ▶ arrow keys allow scrolling between each of the FAULT HIST buffers 1 through 10. The ▲ (UP) and ▼ (DOWN) arrow keys can be used to scroll forwards and backwards through the data in a specific history buffer, once it is displayed.

There is a large amount of data provided under each history. Rather than scroll sequentially through the data in a history, which is possible using the ▼ arrow key, the use of a combination of the ◀, ▶, ▲, and ▼ arrow keys allows fast scrolling to specific data the user desires to view. To use this feature, the user needs to be aware the ◀ and ▶ arrow keys allow scrolling to the top of the data subgroups. Once a specific history is selected, the history data is divided under the subgroups of Unit Data, VSD Data, System Data, Hours/Starts, Setpoints, Options, and Program data. The ◀ and ▶ arrow keys allow moving to the first display under the next or previous subgroup at any time. Once the first display of a subgroup is displayed, the ▲, and ▼ arrow keys allow scrolling through the data in the subgroup. The ▼ arrow key allows scrolling through the data from first to last. When the last piece of data is displayed, the next press of the ▼ arrow key scrolls to the first piece of data in the next subgroup. The ▲ arrow key allows going to the previous display.

Listed below is a description of the fault data displays and their meaning. Data will be displayed in a specific order starting with the Status Display (System Faults only), Fault Display, All Fault Display, Unit Data, VSD Data, System Data, Operating Hours/Starts, Setpoints, Options, and Program Values at the time of the fault.

### Status Fault Type

```

SYS X COMPRESSOR RUNNING
SYS X YYYYYYYY HIGH DIFF OIL PRESSURE
    
```

This message indicates the type of system fault. This screen is skipped if a UNIT Fault caused the shutdown.

### Unit Fault Type

```

UNIT FAULT
LOW AMBIENT TEMP
    
```

This message indicates the type of unit fault. This screen is skipped if a SYSTEM Fault caused the shutdown.

### All Fault Data

```

FAULT HIST XX ALL FAULTS ZZ OF WW
XXXXXXXXXXXXXXXXXXXXXXXXXXXXXXXXXXXXXXXXXXXX
    
```

The ALL FAULT display indicates whether a fault occurred while the unit is shutting down on another fault.

If a control panel fault occurred while the unit is shutting down on a VSD fault before it is reset, the control panel fault is an ALL FAULT of the VSD fault.

If another VSD fault occurs while the unit is shutting down on a VSD fault, the next VSD fault will be registered as an ALL FAULT of the VSD fault.

If a VSD fault occurs during the ramp down shutdown of a control panel fault, the VSD fault is registered as a new fault, not an ALL FAULT

XX is the history number, YYY is the ALL FAULT description, ZZ is the ALL FAULT number and WW is the total number of All Faults for the current history. Sometimes, multiple faults may occur during the shutdown and multiple displays will be observed when scrolling through the data using the ▼ arrow. In most cases, the ALL FAULT display will indicate NONE. The ALL FAULT display will only indicate the cause of the fault. No additional chiller information will be displayed under the ALL FAULT, since a snapshot of all chiller data was taken at the time of the first fault.

**Unit Data****Evaporator Leaving and Return Chilled Liquid Temps**

This message indicates the leaving and entering chilled liquid temperatures at the time of the fault.

**Ambient Air Temperature**

```
UNIT
OUTSIDE AMBIENT AIR TEMP = XXX.X °F
```

This message indicates the ambient air temperature at the time of the fault.

**Load / Unload Timers**

```
UNIT      LOAD TIMER = XXX SEC
          UNLOAD TIMER = XXX SEC
```

This message indicates remaining time on the load and unload timers at the time of the fault.

**Chilled Liquid Temperature Error and Rate of Change**

```
UNIT      TEMP ERROR = XXX.X °F
          RATE = XXX.X °F/M
```

This message indicates the temperature error between the actual and the programmed setpoint at the time of the fault and the rate of temperature change.

**Programmed Lead System Selection and Flow Switch Status**

```
UNIT      LEAD SYSTEM NUMBER = X
          FLOW SWITCH = XXX
```

This message indicates the designated lead system at the time of the fault and whether the flow switch was ON (Closed) or OFF (Open) at the time of the fault.

**Evaporator Pump and Evaporator Heater Status**

```
UNIT      EVAP PUMP RUN = XXX
          EVAP HEATER = XXX
```

This message indicates the status of the evaporator pump and the evaporator heater at the time of the fault. XXX indicates ON or OFF.

**Active Remote Control Status**

```
UNIT ACTIVE REMOTE CONTROL = XXXXXX
```

This message indicates whether the system was operating under Active Remote Control (RCC, ISN, LOAD, TEMP, or SOUND) or standard control (NONE) at the time of the fault.

```
UNIT SOUND LIMIT      LOCAL = XXX %
          ISN = XXX      REMOTE = XXX %
```

This message indicates that sound limiting was in effect, the amount, and whether it was local or remotely limited.

**VSD Data****VSD Actual and Command Frequency**

```
VSD FREQUENCY      ACTUAL = XXX.X HZ
                    COMMAND = XXX.X HZ
```

This message indicates the VSD actual operating frequency and the command frequency at the time of the fault. Actual and command may not match due to load/unload timers, limitation of 1 Hz per load/unload increment, and to allowable acceleration/deceleration of the motor.

```
VSD COMP 1 = XXX AMPS      = XXX %FLA
VSD COMP 2 = XXX AMPS      = XXX %FLA
```

**Compressor AMPS and %FLA**

The message indicates the compressor %FLA and currents for systems 1 and 2 at the time of the fault.

```
COMP 1 = XXX AMPS      = XXX %FLA
COMP 3 = XXX AMPS      = XXX %FLA
```

```
COMP 2 = XXX AMPS      = XXX %FLA
COMP 4 = XXX AMPS      = XXX %FLA
```

These messages indicate the compressor %FLA and currents for systems 3 and 4 at the time of the fault. For 3 compressor units, the #4 compressor information is blanked out.

**VSD Current Limit**

```
VSD CURRENT LIMIT LOCAL = XXX %FLA
ISN = XXX          REMOTE = XXX %FLA
```

This message displays the current limit values as set locally, by an ISN, or a remote current limiting input at the time of the fault.

**DC BUS Voltage**

```
VSD          DC BUS VOLTAGE = XXX VDC
```

```
DC BUS VOLTAGES BUS 1 = XXX VDC
                BUS 2 = XXX VDC
```

This message displays the DC Bus voltage at the time of the fault. On 4 compressor units, the 2nd message will apply since two DC Bus voltages are present (1/3 and 2/4) at the time of the fault.

**VSD Internal Ambient Temp**

```
VSD          INTERNAL AMBIENT TEMP = XXX.X °F
              COOLING SYSTEM STATUS = YYY
```

This message displays the VSD/Microprocessor internal ambient cabinet temperature and the cooling system status (ON or OFF) at the time of the fault.

**IGBT Baseplate Temperature**

```
VSD IGBT BASEPLATE TEMPS T1 = XXX °F
                          T2 = XXX °F
```

This message displays the IGBT highest baseplate temperature for 2 and 3 compressor units at the time of the fault. 4 compressor units display temperatures for 1/3 (T1) and 2/4 (T2).

**Precharge Signal Status and VSD Cooling Status**

```
VSD          PRECHARGE SIGNAL = XXX
```

```
VSD          PRECHARGE 1 SIGNAL = XXX
              PRECHARGE 2 SIGNAL = XXX
```

This display provides the state of the precharge signal, where Precharge 1 and Precharge 2 is either ON or OFF at the time of the fault. Precharge 2 is only used on 4 compressor units.

**Compressor #1 and #2, 105% FLA Motor Overload Current Setting**

```
VSD          COMP 1 MOTOR OVERLOAD = XXX AMPS
              COMP 2 MOTOR OVERLOAD = XXX AMPS
```

This message displays the setting of the VSD's 100% FLA potentiometer for Compressor #1 and #2 at the time of the fault.

**Compressor #3 and #4, 105% FLA Current Setting**

```
COMP 3 MOTOR OVERLOAD = XXX AMPS
COMP 4 MOTOR OVERLOAD = XXX AMPS
```

This message displays the setting of the VSD's 100% FLA potentiometer for Compressor #3 and #4 at the time of the fault.

**System Data****System #1 Pressures**

```
SYS 1 PRESSURES          OIL = XXXX PSIG
SUCTION = XXXX           DISCHARGE = XXXX PSIG
```

This message displays all of the measured system pressures (oil, suction, and discharge) at the time of the fault.

**System # 1 Measured Temperatures**

```
SYS 1 TEMPERATURES      OIL = XXX.X °F
SUCTION = XXX.X          DISCHARGE = XXX.X °F
```

This message displays all of the measured system temperatures (oil, suction, and discharge) at the time of the fault.

**System #1 Measured Suction Temperature and Calculated SAT Suction Temperature and Superheat**

```
SYS 1 SUCTION           TEMP = XXX.X °F
SUPERHEAT = XXX.X       SAT REMP = XXX.X °F
```

This message displays all of the calculated suction temperatures (saturated suction and system superheat) at the time of the fault as well as measured suction temperature.

### System #1 Calculated Discharge Temperatures

**SYS 1 DISCHARGE                      TEMP = XXX.X °F**  
**SUPERHEAT = XXX.X      SAT REMP = XXX.X °F**

This message displays all of the calculated discharge temperatures (saturated discharge and discharge superheat) at the time of the fault as well as measured discharge temperature.

### System #1 Motor Temperatures

**SYS 1 MOTOR TEMPS                      T1 = XXX.X °F**  
**T2 = XXX.X                                  T3 = XXX.X °F**

This message displays the System 1 motor thermistor temperatures at the time of the fault.

### System #1 Compressor Speed and Economizer Solenoid Status

**SYS 1 COMPRESSOR                      SPEED = XXX.X %**  
**ECONOMIZER SOLENOID = XXX**

This message indicates the compressor speed and status of economizer solenoid at the time of the fault. The economizer status will be indicated as either ON or OFF.

### System #1 Flash Tank Level and Feed Valve % Open

**SYS 1 FLASH TANK                      LEVEL = XXX.X %**  
**FEED VALVE PERCENT OPEN = XXX.X %**

This message displays the liquid level in the flash tank and indicates the % the Flash Tank Feed Valve is open at the time of the fault.

### System #1 Suction Superheat and Flash Tank Drain Valve % Open

**SYS 1    SUCTION SUPERHEAT = XXX.X °F**  
**DRAIN VALVE PERCENT OPEN = XXX.X %**

This message displays the system suction superheat and indicates the % the Flash Tank Drain Valve is open at the time of the fault.

### System #1 Fan Stage and Compressor Heater Status

**SYS 1 CONDENSER FANS ON = XXX**  
**COMPRESSOR HEATER = XXX**

This message displays the actual # of system fans on, and the status of the compressor heater at the time of the fault. The fan display will show the number of fans operating while the compressor heater status will indicate either ON or OFF.

### Compressor #1 Run Time

**SYS 1 RUN TIME**  
**XX DAYS XX HOURS XX MINUTES XX SECONDS**

This message displays the system run time since the last start in days, hours, minutes, and seconds at the time of the fault.

### System #1 Run Signals

**SYS 1 RUN SIGNALS                      RELAY = XXX**  
**RUN PERM = XXX                          SOFTWARE = XXX**

This message displays the System Run Signal Relay (Relay Output Board) status, Run Permissive Input status, and the Internal Software (microprocessor command) ON/OFF Start status. The status of each will indicate either ON or OFF.

### System 2 through 4 Data

Data for the remaining systems 2 through 4 at the time of the fault is displayed in the same sequence as the system #1 data.

### Compressor Operating Hours and Starts

**HOURS 1=XXXXX, 2=XXXXX, 3=XXXXX, 4=XXXXX**  
**START 1=XXXXX, 2=XXXXX, 3=XXXXX, 4=XXXXX**

This message displays compressor operating hours and compressor starts at the time of the fault. On 3 and 4 compressor units, the data and compressor designators for compressors not present will be blanked out.

### Chilled Liquid Setpoint Cooling Setpoints

```
SETPOINTS
LOCAL COOLING SETPOINT = XXX.X °F
```

This message displays the programmed cooling setpoint at the time of the fault.

```
SETPOINTS
LOCAL CONTROL RANGE = +/- X.X °F
```

This message displays the programmed Control Range at the time of the fault.

#### Remote Setpoint and Range

```
SETPOINTS REMOTE SETPOINT = XXX.X °F
REMOTE CONTROL RANGE = +/- X.X °F
```

This message displays the remote setpoint and Control Range at the time of the fault.

#### Maximum Remote Temperature Setpoint

```
SETPOINTS
MAXIMUM REMOTE TEMP RESET = XXX.X °F
```

This message displays the maximum remote reset programmed at the time of the fault.

#### Options

##### Display Language

```
OPTIONS DISPLAY LANGUAGE
< > XXXXXXXXXXXXXXXXXXXXXXXX
```

This message displays the language selected at the time of the fault.

##### Chilled Liquid Cooling Mode

```
OPTIONS CHILLED LIQUID COOLING MODE
< > WATER COOLING
```

This message displays the chilled liquid temperature mode (water or glycol) selected at the time of the fault.

##### Local / Remote Control Mode

```
OPTIONS CHILLED LIQUID COOLING MODE
< > GLYCOL COOLING
```

This message indicates whether Local or Remote Control Mode was selected at the time of the fault.

```
OPTIONS LOCAL / REMOTE CONTROL MODE
< > XXXXXXXXXXXXXXXXXXXXXXXX
```

When Remote Control Mode is selected, control of the Chilled Liquid Setpoint is from a remote device such as an ISN/BAS controller.

```
OPTIONS DISPLAY UNITS
< > XXXXXXXXXXXXXXXXXXXXXXXX
```

##### Display Units Mode

This message indicates whether SI (°C, Barg) or Imperial units (°F, PSIG) was selected at the time of the fault.

```
OPTIONS LEAD / LAG CONTROL MODE
< > XXXXXXXXXXXXXXXXXXXXXXXX
```

##### System Lead/Lag Control Mode

This message indicates the type of lead lag control selected at the time of the fault. Five choices are available:

- Automatic
- Sys 1 Lead
- Sys 2 Lead
- Sys 3 Lead
- Sys 4 Lead.

The default mode will be AUTOMATIC.

##### Remote Temperature Reset

One of the 5 messages below indicates whether remote temperature reset was active or disabled at the chiller keypad at the time of the fault. If active, the type of reset signal selected is indicated. If the option is not factory enabled, the option will not appear.

```
OPTIONS REMOTE TEMP RESET INPUT
< > DISABLED
```

```
OPTIONS REMOTE TEMP RESET INPUT
< > 0.0 TO 10.0 VOLTS DC
```

```
OPTIONS REMOTE TEMP RESET INPUT
< > 2.0 TO 10.0 VOLTS DC
```

```
OPTIONS REMOTE TEMP RESET INPUT
< > 0.0 TO 20.0 MILLIAMPS
```

```
OPTIONS REMOTE TEMP RESET INPUT
< > 4.0 TO 20.0 MILLIAMPS
```

**Low Ambient Temp Cutout**

```

OPTIONS      LOW AMBIENT TEMP CUTOUT
◀ ▶         XXXXXXXXXXXXXXXXXXXXXXXX

```

This message indicates whether the low ambient cutout was enabled or disabled at the time of the fault.

**Remote Current Reset**

```

OPTIONS      REMOTE CURRENT LIMIT INPUT
◀ ▶         DISABLED

```

```

OPTIONS      REMOTE CURRENT LIMIT INPUT
◀ ▶         0.0 TO 10.0 VOLTS DC

```

```

OPTIONS      REMOTE CURRENT LIMIT INPUT
◀ ▶         2.0 TO 10.0 VOLTS DC

```

```

OPTIONS      REMOTE CURRENT LIMIT INPUT
◀ ▶         0.0 TO 20.0 MILLIAMPS

```

```

OPTIONS      REMOTE CURRENT LIMIT INPUT
◀ ▶         4.0 TO 20.0 MILLIAMPS

```

This message indicates whether remote current reset was active or disabled at the chiller keypad at the time of the fault and if active, the type of reset signal selected. One of the following messages will be indicated: DISABLED (no signal)

- 0 to 10VDC
- 2 to 10VDC
- 0 to 20ma
- 4 to 20ma.

If the option is not factory enabled, the option will not appear.

**Program Values****Suction Pressure Cutout**

```

PROGRAM
SUCTION PRESSURE CUTOUT = XXX.X PSIG

```

This message indicates the suction pressure cutout programmed at the time of the fault.

**Low Ambient Cutout**

```

PROGRAM
LOW AMBIENT TEMP CUTOUT = XXX.X °F

```

This message displays the low ambient temp cutout programmed at the time of the fault.

**Low Leaving Chilled Liquid Temp Cutout**

```

PROGRAM
LEAVING LIQUID TEMP CUTOUT = XXX.X °F

```

This message displays the low leaving Chilled liquid temperature cutout programmed at the time of the fault.

**Motor Current Limit**

```

PROGRAM
MOTOR CURRENT LIMIT      = XXX %FLA

```

This message indicates the motor current limit programmed at the time of the fault.

**Pulldown Current Limit**

```

PROGRAM
PULLDOWN CURRENT LIMIT  = XXX %FLA

```

This message indicates the pulldown current limit programmed at the time of the fault.

**Pulldown Current Limit Time**

```

PROGRAM
PULLDOWN CURRENT LIMIT TIME = XXX MIN

```

This message indicates the pulldown current limit time programmed at the time of the fault.

**Suction Superheat Setpoint**

```

PROGRAM
SUCTION SUPERHEAT SETPOINT = XXX.X °F

```

This message indicates the suction superheat setpoint programmed at the time of the fault.

**Unit ID Number**

```

PROGRAM
REMOTE UNIT ID NUMBER    = X

```

This indicates the unit ID # programmed at the time of the fault.

**Sound Limit Setpoint**

```

PROGRAM
SOUND LIMIT SETPOINT     = XXX %

```

This indicates the sound limit setpoint programmed at the time of the fault, if the sound limit option is activated at the factory. If the option is not factory activated, the display will not appear.

## SETPOINTS KEY

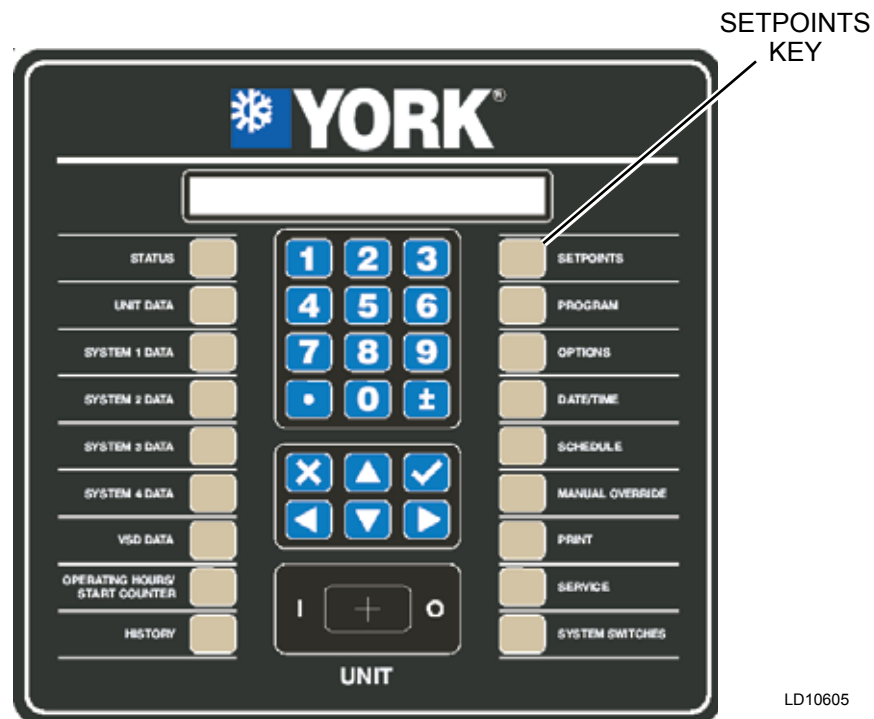

LD10605

### Setpoints Key Operation

Cooling setpoints and ranges may be programmed by pressing the SETPOINTS key. The first setpoint entry screen will be displayed as shown below. The first line of the display will show the chiller default (DEF), minimum acceptable value (LO) and maximum acceptable value (HI). The second line shows the actual programmed value. TABLE 16 also shows the allowable ranges for the cooling setpoints and Control Ranges. Note that the Imperial units are exact values while the Metric units are only approximate.

```
SETPOINTS ◀DEF XXXXX LO XXXXX HI XXXXX
LOCAL COOLING SETPOINT = XXX.X °F
```

Pressing the SETPOINTS key a second time or the ▼ (ARROW) key will display the leaving chilled liquid Control Range, default, and low/high limits.

```
SETPOINTS ◀DEF XXXXX LO XXXXX HI XXXXX
LOCAL CONTROL RANGE = +/- X.X °F
```

Pressing the SETPOINTS key or the ▼ (ARROW) key a third time will display the remote setpoint and cooling range. This display automatically updates about every 2 seconds. This remote setpoint message is shown below:

```
SETPOINTS REMOTE SETPOINT = XXX.X °F
REMOTE CONTROL RANGE = +/- X.X °F
```

If there is no remote setpoint being utilized, the remote setpoint value will be displayed as XXXXXX and the remote Control Range will display XXX.

Pressing the SETPOINTS key or the Arrow key a fourth time will bring up a screen that allows the Maximum Remote Temperature Reset to be programmed. This message is shown below:

```
SETPOINTS ◀DEF XXXXX LO XXXXX HI XXXXX
MAXIMUM REMOTE TEMP RESET = XXX.X °F
```

The values displayed under each of the key presses may be changed by keying in new values and pressing the ✓ (ENTER) key to store the new value into memory. Where more than one value may be keyed in on a display, a portion of the data that does not need updating may be skipped by pressing the ✓ (ENTER) key. The ✓ (ENTER) key must also be pressed after the last value in the display to store the data into memory.

The ▲ (ARROW) key allows scrolling back through the setpoints displays.

The minimum, maximum, and default values allowed under the SETPOINTS key are provided in TABLE 16.

**TABLE 16 - SETPOINT LIMITS**

PROGRAM VALUE	MODE	LOW LIMIT	HIGH LIMIT	DEFAULT
Leaving Chilled Liquid Setpoint	Water Cooling	40.0°F	60.0°F	44.0°F
		4.4°C	15.6°C	6.7°C
	Glycol Cooling	15.0°F	70.0°F	44.0°F
		-9.4°C	15.6°C	6.7°C
Leaving Chilled Liquid Control Range	-	1.5°F	2.5°F	2.0°F
		0.8°C	1.4°C	1.1°C
Max. Remote Temperature Reset	-	2°F	40°F	20°F
		1°C	22°C	11°C

## PROGRAM KEY

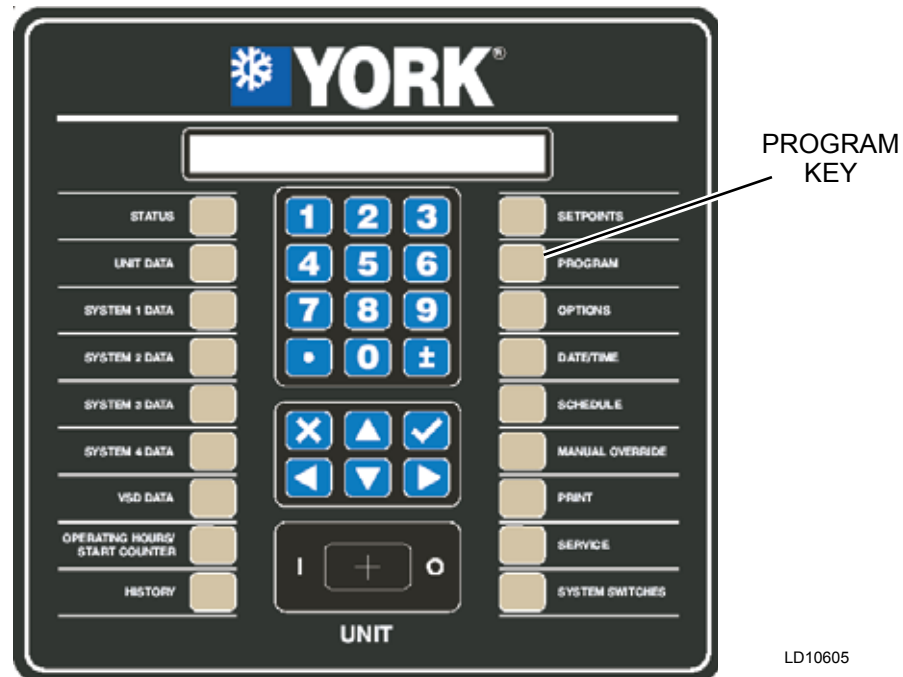

LD10605

### Program Key Operation

Various operating parameters are programmable by the user. These are modified by pressing the PROGRAM key and then the ✓ (ENTER) key to enter Program Mode. A listing of the limits of the programmable values is found below. Note that the Imperial units are exact values, while Metric units are only approximate.

The ▲ and ▼ (ARROW) keys are used to scroll through the user programmable values. A value may be changed by keying in the new value and pressing the ✓ (ENTER) key to store the new value in memory. The cursor will be displayed on the screen when a number key is pressed. The first line of each message will indicate the chiller default (DEF) value), lowest acceptable programmable value (LO), and highest acceptable programmable value (HI). The user programmable value is programmed on in the second line of the message.

When the PROGRAM key is first pressed, the following display will appear indicating the user is in the program mode:

```
PROGRAM MODE XXXX
PRESS ENTER KEY TO CONTINUE
```

Pressing the ✓ (ENTER) key again will display the first programmable selection.

### Suction Pressure Cutout

```
PROGRAM ◀DEF XXXXX LO XXXXX HI XXXXX
SUCTION PRESSURE CUTOUT = XXX.X PSIG
```

The suction pressure cutout is protects the chiller from a low refrigerant condition. It also helps protect from a freeze-up due to low or no chilled liquid flow. However, it is only a back-up for a flow switch and cannot protect against an evaporator freeze under many conditions. This cutout is programmable and should generally be programmed for 24PSIG (1.65 Barg) for chilled water cooling.

The cutout is programmable between 24.0 and 36.0 PSIG (1.65 and 2.48 Barg) in the Water Cooling mode and 5.0 and 36.0 (0.34 and 2.28 Barg) in the Glycol Cooling mode. The default value for both modes will be 24.0 PSIG (1.65 Barg) PSIG.

## Low Ambient Cutout

```
PROGRAM ◀DEF XXXXX LO XXXXX HI XXXXX
LOW AMBIENT TEMP CUTOUT = XXX.X °F
```

The low ambient temp cutout allows programming the outdoor temperature at which it is desired to shut down the chiller to utilize other methods of cooling.

The cutout is programmable between  $-2.0^{\circ}\text{F}$  ( $-18.9^{\circ}\text{C}$ ) and  $50^{\circ}\text{F}$  ( $10.0^{\circ}\text{C}$ ) with a  $25^{\circ}\text{F}$  ( $-3.9^{\circ}\text{C}$ ) default.

## Low Leaving Liquid Temp Cutout

```
PROGRAM ◀DEF XXXXX LO XXXXX HI XXXXX
LEAVING LIQUID TEMP CUTOUT = XXX.X °F
```

The leaving chilled liquid temp cutout is programmed to avoid freezing the evaporator due to excessively low chilled liquid temperatures. The cutout is automatically set at  $36^{\circ}\text{F}$  ( $2.2^{\circ}\text{C}$ ) in the Water Cooling mode and is programmable in the Glycol Cooling mode. In the Glycol Cooling Mode, the cutout is programmable from  $11.0^{\circ}\text{F}$  to  $36.0^{\circ}\text{F}$  ( $-11.7$  to  $2.2^{\circ}\text{C}$ ) with a default of  $36.0^{\circ}\text{F}$  ( $2.2^{\circ}\text{C}$ ).

## Motor Current Limit

```
PROGRAM ◀DEF XXXXX LO XXXXX HI XXXXX
MOTOR CURRENT LIMIT = XXX % FLA
```

The motor current limit %FLA is programmable. This allows the microprocessor to limit a system before it faults on high current. Typically, the limit point is set at 100%. The unload point is programmable from 30 to 100% with a default of 100%.

## Pulldown Current Limit

```
PROGRAM ◀DEF XXXXX LO XXXXX HI XXXXX
PULLDOWN CURRENT LIMIT = XXX % FLA
```

The pulldown current limit %FLA is programmable. This allows the microprocessor to limit a system on pulldown limiting for the purpose of peak time energy savings. Typically, the limit point is set at 100%. The pulldown limit point is programmable from 30 to 100% with a default of 100%. Be aware when using pulldown motor current limit, the chiller may not be able to load to satisfy temperature demand

## Pulldown Current Limit Time

```
PROGRAM ◀DEF XXXXX LO XXXXX HI XXXXX
PULLDOWN CURRENT LIMIT TIME = XXX MIN
```

The pulldown current limit time is programmable. This allows the microprocessor to limit a system on pulldown limiting for a defined period of time for the purpose of peak time energy savings. The pulldown limit point is programmable from 0 to 255 with a default of 0 Min.

## Suction Superheat Setpoint

```
PROGRAM ◀DEF XXXXX LO XXXXX HI XXXXX
SUCTION SUPERHEAT SETPOINT = XXX.X °F
```

The suction superheat setpoint is programmable from  $8.0$  to  $12.0^{\circ}\text{F}$  ( $4.4$  to  $8.3^{\circ}\text{C}$ ) with a  $10.0^{\circ}\text{F}$  ( $5.6^{\circ}\text{C}$ ) default. Typically the superheat control will be programmed for  $10.0^{\circ}\text{F}$ . Higher superheats between 10 and  $12^{\circ}\text{F}$  will reduce the risk of liquid carry over and are preferred by some users.

## Unit ID Number

```
PROGRAM ◀DEF XXXXX LO XXXXX HI XXXXX
REMOTE UNIT ID NUMBER = X
```

For purposes of remote communications, multiple chillers may be connected to an RS-485 communications bus. To allow communications to each chiller, a chiller ID number may be programmed into memory. On a single chiller application, the value will be "0".

## Sound Limit Setpoint

```
PROGRAM <DEF XXXXX LO XXXXX HI XXXXX
SOUND LIMIT SETPOINT = XXX %
```

The sound limit setpoint is programmable from 0 to 100 % with a 0% default. 0% allows operating up to the full speed capability of the unit with no sound limiting. Typically the sound limit control setting will be programmed for 0 % unless sound limiting is utilized on the chiller. Sound limiting will only permit the unit to run to a frequency less than the maximum speed capability of the unit. Programming a value of 1% would be the minimum sound limiting that can be programmed and 100% will be the maximum. 100% will only allow the unit speed to operate at the minimum frequency. Usually, the sound limit % will be programmed somewhere between 0 and 100% according to the limiting needed to satisfy the sound requirements of the site. Typically, sound limiting will be utilized in areas sensitive to noise during night-time hours. The sound limit display will only be present if the sound limit option is programmed at the factory.

## Default Values

A listing of the low limits, high limits, and default values for each of the programmable values is noted in each display and can be found in TABLE 17. Note that the Imperial units are exact values while the Metric units are only approximate.

**TABLE 17 - PROGRAMMABLE OPERATING PARAMETERS**

PROGRAM VALUE	MODE	LOW LIMIT	HIGH LIMIT	DEFAULT
Suction Pressure Cutout	Water Cooling	24.0 PSIG	36.0 PSIG	24.0 PSIG
		1.65 Bars	2.48 Bars	1.65 Bars
	Glycol Cooling	5.0 PSIG	36.0 PSIG	24.0 PSIG
		0.34 Bars	2.48 Bars	1.65 Bars
Low Ambient Temp. Cutout	-	-2°F	50.0°F	25.0°F
		-18.9°C	10.0°C	2.2°C
Leaving Chilled Liquid Temp. Cutout	Water Cooling	-	-	36.0°F
		-	-	2.2°C
	Glycol Cooling	11.0°F	36.0°F	36.0°F
		-11.7°C	2.2°C	2.2°C
Motor Current Limit	-	30%	103%	103%
Pulldown Motor Current Limit	-	30%	100%	100%
Pulldown Motor Current Limit Time	-	0 Min	255 Min	0 Min
Suction Superheat Setpoint	-	8.0°F	12.0°F	10.0°F
		4.4°C	6.6°C	5.6°C
Unit ID Number	-	0	7	0
Sound Limit Setpoint	Sound Limit Option Enabled	0%	100%	0%

## OPTIONS KEY

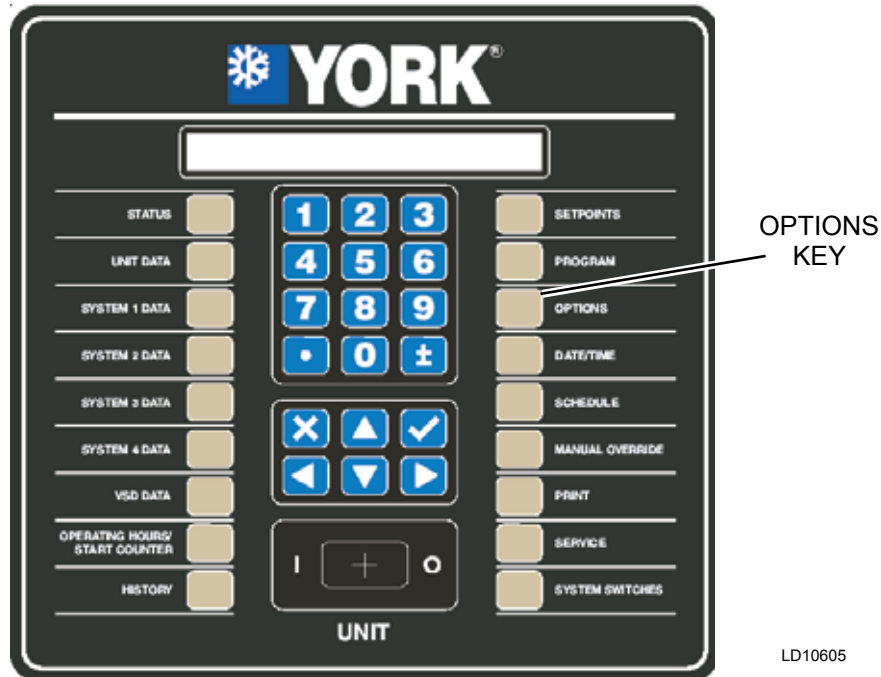

LD10605

### Options Key Operation

The OPTIONS key provides the user with a display of unit configuration and the capability to modify the configuration. These options can only be viewed under the OPTIONS key. To view the current options settings, press the OPTIONS key. Each press of the OPTIONS key or press of the ▲ or ▼ (ARROW) keys will scroll to the next option setting. The ◀ and ▶ (ARROW) keys allow changing the option choices. The ✓ (ENTER) key must be pressed after a selection is made to save the change in memory.

An explanation of each option message is provided below.

### Display Language Selection

The display language can be selected for English, Dutch, German, Italian, and Chinese



The default language will be English.

### Chilled Liquid Cooling Mode Selection

The Chilled liquid cooling mode can be selected for Water Cooling or low temperature Glycol Cooling.



When Water Cooling is chosen, the chilled liquid temperature setpoint can only be programmed from 40°F to 70°F



When Glycol Cooling is chosen, the chilled liquid temperature setpoint can be programmed from 10°F to 70°F.



The default Chilled Liquid Mode will be WATER.

### Local / Remote Control Mode Selection

Local or Remote Control Mode allows the user to select the chilled liquid temperature control mode.

```

OPTIONS   LOCAL / REMOTE CONTROL MODE
◀ ▶      XXXXXXXXXXXXXXXXXXXXX
    
```

When LOCAL CONTROL mode is selected, chilled liquid control is from the keypad of the chiller. In local mode, a remote device can read system data, but not reset operating parameters.

```

OPTIONS   LOCAL / REMOTE CONTROL MODE
◀ ▶      LOCAL CONTROL
    
```

When REMOTE CONTROL mode is selected, control of the chilled liquid setpoint is from a remote device such as an ISN/BAS controller.

```

OPTIONS   LOCAL / REMOTE CONTROL MODE
◀ ▶      REMOTE CONTROL
    
```

The default mode will be LOCAL.

### Display Units Selection

Imperial or SI display units may be selected for data display.

```

OPTIONS   DISPLAY UNITS
◀ ▶      XXXXXXXXXXXXXXXXXXXXX
    
```

The user may select system operating temperatures and pressures to be displayed in either SI (°C, Barg) or Imperial units (°F, PSIG).

```

OPTIONS   DISPLAY UNITS
◀ ▶      IMPERIAL
    
```

```

OPTIONS   DISPLAY UNITS
◀ ▶      SI
    
```

The default mode is IMPERIAL.

### System Lead/Lag Control Mode Selection

The operator may select the type of lead/lag control desired.

```

OPTIONS   LEAD / LAG CONTROL MODE
◀ ▶      XXXXXXXXXXXXXXXXXXXXX
    
```

In most cases, automatic lead/lag will be selected. When automatic lead/lag is selected, the microprocessor will attempt to balance run time by switching the lead compressor whenever all compressors are shut off. If a compressor is not able to run when the microprocessor attempts a start, the microprocessor will select another compressor in an effort to control chilled liquid temperature. Manual lead/lag allows selecting a specific compressor to be the lead. If #2 is selected as the lead in a 3 compressor chiller, the sequence will be 2, 3, and 1.

```

OPTIONS   LEAD / LAG CONTROL MODE
◀ ▶      AUTOMATIC
    
```

The default mode will be AUTOMATIC.

Lag selections of individual systems will appear as:

```

OPTIONS   LEAD / LAG CONTROL MODE
◀ ▶      MANUAL SYS 1 LEAD
    
```

```

OPTIONS   LEAD / LAG CONTROL MODE
◀ ▶      MANUAL SYS 2 LEAD
    
```

```

OPTIONS   LEAD / LAG CONTROL MODE
◀ ▶      MANUAL SYS 3 LEAD
    
```

SYSTEM 3 LEAD may be selected only on 3 and 4 compressor units.

```

OPTIONS   LEAD / LAG CONTROL MODE
◀ ▶      MANUAL SYS 4 LEAD
    
```

SYSTEM 4 LEAD may be selected only on 4 compressor units.

**Remote Temperature Reset Selection**

Remote temperature reset from an external source may be tied directly into the chiller microprocessor board.

OPTIONS REMOTE TEMP RESET INPUT  
◀ ▶ XXXXXXXXXXXXXXXXXXXXXXXX

Selections may be made for DISABLED (no signal), 0 to 10VDC, 2 to 10VDC, 0 to 20ma, and 4 to 20ma.

OPTIONS REMOTE TEMP RESET INPUT  
◀ ▶ DISABLED

OPTIONS REMOTE TEMP RESET INPUT  
◀ ▶ 0.0 TO 10.0 VOLTS DC

OPTIONS REMOTE TEMP RESET INPUT  
◀ ▶ 2.0 TO 10.0 VOLTS DC

OPTIONS REMOTE TEMP RESET INPUT  
◀ ▶ 0.0 TO 20.0 MILLIAMPS

OPTIONS REMOTE TEMP RESET INPUT  
◀ ▶ 4.0 TO 20.0 MILLIAMPS

The default setting for Remote Temp Reset is DISABLED. This display will only appear if the remote temp limit option is enabled at the factory.

**Remote Current Limit Input Selection**

Remote current limit from an external source may be tied directly into the chiller microprocessor board.

OPTIONS REMOTE CURRENT LIMIT INPUT  
◀ ▶ XXXXXXXXXXXXXXXXXXXXXXXX

Selections may be made for DISABLED (no signal), 0 to 10VDC, 2 to 10VDC, 0 to 20ma, and 4 to 20ma.

OPTIONS REMOTE CURRENT LIMIT INPUT  
◀ ▶ DISABLED

OPTIONS REMOTE CURRENT LIMIT INPUT  
◀ ▶ 0.0 TO 10.0 VOLTS DC

OPTIONS REMOTE CURRENT LIMIT INPUT  
◀ ▶ 2.0 TO 10 VOLTS DC

OPTIONS REMOTE CURRENT LIMIT INPUT  
◀ ▶ 0.0 TO 20.0 MILLIAMPS

OPTIONS REMOTE CURRENT LIMIT INPUT  
◀ ▶ 4.0 TO 20.0 MILLIAMPS

The default setting for Remote Current Reset is DISABLED. This display will only appear if the remote current limit option is enabled at the factory.

**Remote Sound Limit Selection**

Remote sound limit from an external source may be tied directly into the chiller microprocessor board.

OPTIONS REMOTE SOUND LIMIT INPUT  
◀ ▶ XXXXXXXXXXXXXXXXXXXXXXXX

Selections may be made for DISABLED (no signal), 0 to 10VDC, 2 to 10VDC, 0 to 20ma, and 4 to 20ma.

OPTIONS REMOTE SOUND LIMIT INPUT  
◀ ▶ DISABLED

OPTIONS REMOTE SOUND LIMIT INPUT  
◀ ▶ 0.0 TO 10.0 VOLTS DC

OPTIONS REMOTE SOUND LIMIT INPUT  
◀ ▶ 2.0 TO 10.0 VOLTS DC

OPTIONS REMOTE SOUND LIMIT INPUT  
◀ ▶ 0.0 TO 20.0 MILLIAMPS

OPTIONS REMOTE SOUND LIMIT INPUT  
◀ ▶ 4.0 TO 20.0 MILLIAMPS

The default setting for Remote Sound Limit is DISABLED. This display will only appear if the remote sound limit option is enabled at the factory.

**Low Ambient Cutout Enable/Disable**

The low ambient cutout may be enabled or disabled. When enabled, the chiller will cut off when the low ambient cutout is reached. When disabled, the chiller will run at any temperature.

OPTIONS LOW AMBIENT TEMPERATURE CUTOUT  
◀ ▶ ENABLED

OPTIONS LOW AMBIENT TEMPERATURE CUTOUT  
◀ ▶ DISABLED

The default setting for the low ambient cutout will be ENABLED.

## DATE/TIME AND SCHEDULE KEYS

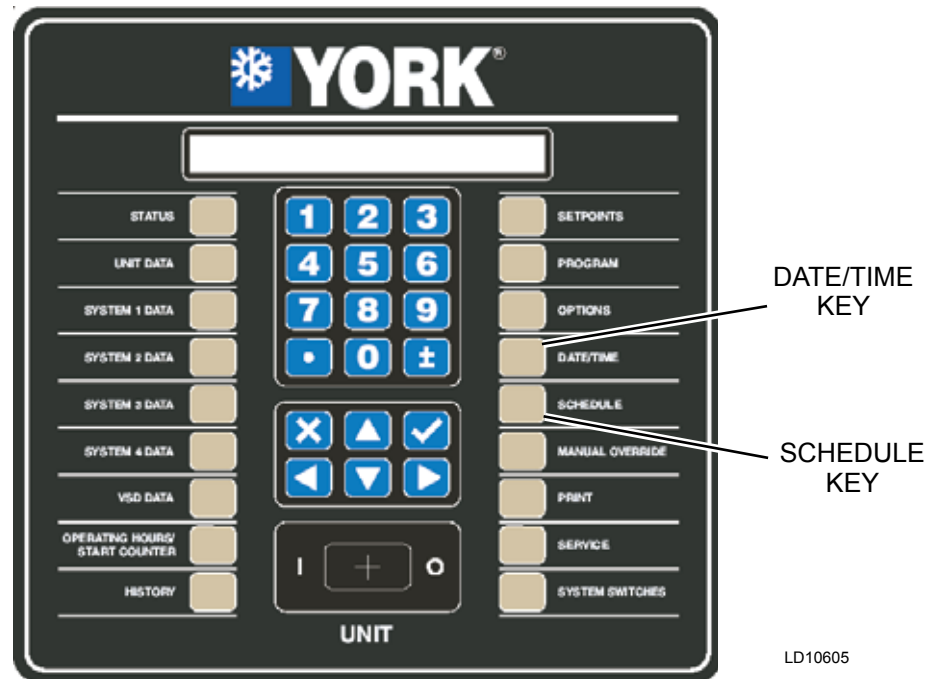

### Date/Time Key Operation

When the DATE/TIME key is pressed, the chiller microprocessor will display the date and the time. This feature is useful and required for using the Daily Schedule. It is also a valuable tool for troubleshooting to allow a technician to determine the time of the fault, which is stored in the history memory buffers. When the DATE/TIME key is pressed, the first display screen shown below will be displayed:

**CLOCK FRI 18-JUN-2005 10:15:33 AM**  
**DAY OF WEEK ◀ ▶ = XXX**

Whenever any changes are made, the ✓ (ENTER) key must be pressed to store the data.

Pressing the ▲ or ▼ (ARROW) keys allows scrolling to the next programmed item. Pressing the ▼ (DOWN ARROW) key scrolls to the next item that can be programmed and the ▲ (UP ARROW) key scrolls to the previous item.

The day of the week is the first display and can be changed by pressing either the ◀ or ▶ (LEFT OR RIGHT ARROW) key to select the day. After the day is selected, the ✓ (ENTER) key must be pressed to store the data.

**CLOCK FRI 18-JUN-2005 10:15:33 AM**  
**DAY OF MONTH = XX**

Pressing the ▼ (DOWN ARROW) key again scrolls to the day of the month:

**CLOCK FRI 18-JUN-2005 10:15:33 AM**  
**DAY OF MONTH = XX**

The day of the month can be selected by keying in the numerical value to select the day. After the day of the month is selected, the ✓ (ENTER) key must be pressed to store the data.

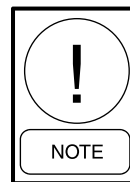

*A "0" must be typed in to select dates for days of the 1st through the 9th.*

Pressing the ▼ (DOWN ARROW) key again scrolls to month:

**CLOCK FRI 18-JUN-2005 10:15:33 AM**  
**MONTH ◀ ▶ = XX**

The month can be selected by keying in the numerical value to select the day. After the month is selected, the ✓ (ENTER) key must be pressed to store the data.

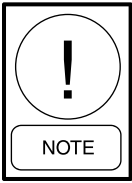

*A "0" must be keyed in for months 01 through 09. The panel will automatically provide the abbreviation of the month.*

Pressing the ▼ (DOWN ARROW) key again scrolls to the year:

**CLOCK FRI 18-JUN-2005 10:15:33 AM**  
**YEAR = XXXX**

The year can be selected by keying in the numerical value to select the year. After the year is selected, the ✓ (ENTER) key must be pressed to store the data.

Pressing the ▼ (DOWN ARROW) key again scrolls to the hour:

**CLOCK FRI 18-JUN-2005 10:15:33 AM**  
**HOUR = XX**

The hour can be selected by keying in the numerical value for the hour. After the hour is selected, the ✓ (ENTER) key must be pressed to store the data.

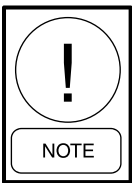

*One or two "0's" must be keyed in for hours 00-09.*

Pressing the ▼ (DOWN ARROW) key again scrolls to the minute:

**CLOCK FRI 18-JUN-2004 10:15:33 AM**  
**MINUTE = XX**

The minute can be selected by keying in the numerical value for the hour. After the minute is selected, the ✓ (ENTER) key must be pressed to store the data.

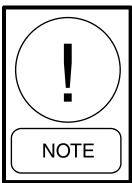

*One or two "0's" must be keyed in for minutes 00 through 09.*

Pressing the ▼ (DOWN ARROW) key again scrolls to AM/PM:

**CLOCK FRI 18-JUN-2004 10:15:33 AM**  
**AM/PM ◀ ▶ = XX**

AM/PM can be selected by pressing the ◀ or ▶ (ARROW) keys. After the meridian is selected, the ✓ (ENTER) key must be pressed to store the data.

Pressing the ▼ (DOWN ARROW) key again scrolls to the time format selection:

**CLOCK FRI 18-JUN-2004 10:15:33 AM**  
**TIME FORMAT ◀ ▶ = XXXXXXXX**

The time format may be displayed in either a 12 hour or 24 hour format. Selection can be changed by pressing the ◀ or ▶ (ARROW) keys. The ✓ (ENTER) key must be pressed to store the data.

**Schedule Key Operation**

The Daily Schedule must be programmed for the unit start and stop times. To set the schedule, press the SCHEDULE key. The display will provide a message allowing access to 2 types of schedule information:

**SCHEDULE CHOOSE SCHEDULE TYPE**  
**◀ ▶ XXXXXXXXXXXXXXXXXXXXXXXXXXXX**

The schedule types are:

- UNIT OPERATING SCHEDULE
- (Default selection)
- SOUND LIMIT SCHEDULE  
 (Only if Sound Limiting is enabled by the factory when the option is installed.)

The schedule type (UNIT OPERATING SCHEDULE or SOUND LIMIT SCHEDULE) may be changed by pressing the ◀ (LEFT ARROW) or ▶ (RIGHT ARROW) keys followed by the ✓ (ENTER) key. The selection must be entered by pressing the ✓ (ENTER) key before a schedule display will appear.

### Unit Operating Schedule

The Unit Operating Schedule is used to enable/disable the chiller unit on time of day. The chiller can be enabled and disabled once each day or it can be programmed to run continuously. Any time the daily or holiday schedule shuts the chiller down, the running system(s) will go through a controlled ramped shut-down. If the UNIT OPERATING SCHEDULE is selected under the CHOOSE SCHEDULE display, the following message will appear:

```
SCHEDULE    UNIT OPERATING
MON START = 06:00 AM  STOP = 10:00 PM
```

The line under the 0 is the cursor. If the start time is wrong, it can be changed by keying in the new time from the numeric keypad. Once the correct values for the START hour and minute are entered, press the ✓ (ENTER) key. The cursor will then move to the AM/PM selection. The meridian (AM/PM) value may be changed by the ◀ (LEFT ARROW) or ▶ (RIGHT ARROW) keys and entered by pressing ✓ (ENTER) key. Repeat this process for the STOP time. Once a schedule is entered, the schedule for the next day will appear. The start and stop time of each day may be programmed differently. To view the schedule without making a change, simply press the SCHEDULE key until the day you wish to view appears. The ▲ (UP ARROW) key will scroll backwards to the previous screen.

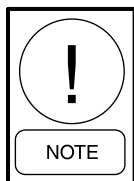

***If at any time the schedule is changed for Monday, all the other days will change to the new Monday schedule. This means if the Monday times are not applicable for the whole week, then the exceptional days would need to be reprogrammed to the desired schedule.***

To program the chiller for 24 hour operation, program the start and stop times of each day of the week for 00:00.

After the SUN (Sunday) schedule appears on the display, a subsequent press of the SCHEDULE or ▲ (UP ARROW) key will display the Holiday schedule. This is a two-part display. The first reads:

```
SCHEDULE    UNIT OPERATING
HOL START = 00:00 AM  STOP = 00:00 PM
```

The holiday times may be set using the same procedure as described above for the days of the week. Be sure to press the ✓ (ENTER) key after setting the START and STOP times to save the change in memory. Pressing the SCHEDULE key a second time, the display will show the individual days:

```
SCHEDULE    UNIT OPERATING
S M T W T F S  HOLIDAY NOTED BY *
```

The line below the empty space is the cursor and will move to the next or previous empty space when the ◀ (LEFT ARROW) or ▶ (RIGHT ARROW) keys and pressed. To set a day for the Holiday Schedule, the cursor must be moved to the space following the day of the week. The \* key is then pressed and an “\*” will appear in the space signifying that day as a holiday. The Holiday schedule must be programmed weekly. If there is no holiday, the “\*” key is also used to delete the “\*”. The ✓ (ENTER) key is used to accept the holiday schedule for the entire week.

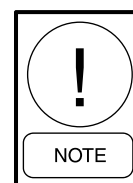

***The HOLIDAYSCHEDULE is a temporary schedule. Once the schedule is executed, the selected holidays will be cleared from memory for the following week.***

## Sound Limit Schedule

The SOUND LIMIT SCHEDULE allows setting the day and time when the user desires using the “SILENT NIGHT” factory programmed option to limit chiller loading and fan operation for reduced audible noise in the surrounding area. If the SOUND LIMIT SCHEDULE is selected under the CHOOSE SCHEDULE display, the following message will appear:

```
SCHEDULE   SOUND LIMIT = XXX %
MON START = 06:00 AM  STOP = 10:00 PM
```

The Sound Limit option can be enabled and disabled once each day or the chiller can be set to run continuously in this mode for sound limiting whenever the chiller is operating. When sound limiting is enabled, the unit will be limited by the Sound Limit setpoint % as set under the PROGRAM key. XXX in the display above will show the Sound Limit Setpoint % programmed under the PROGRAM key. 0% will cause no speed reduction, while 100% only allows running at minimum speed.

The START Time for a specific day (hour and minute) is entered using the same guidelines used for the start/stop schedules, and press the ✓ (ENTER) key to store it into memory. The cursor will then move to the AM/PM selection.

The AM/PM selection may be chosen using the ◀ (LEFT ARROW) or ▶ (RIGHT ARROW) keys and pressing ✓ (ENTER) key to store the value.

This process is repeated for the STOP time.

Once the schedule for a specific day is programmed and entered, the schedule for the next day will appear. The schedule for each day may be programmed the same or differently.

To view the schedule without changing it, simply press the SCHEDULE key or the ▼ (DOWN ARROW) key until the desired day is displayed. The ▲ (UPARROW) key will scroll backwards to the previous screen.

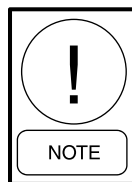

***If the schedule is changed for Monday, all other days will change to the Monday schedule. Be aware of this when programming.***

## MANUAL OVERRIDE KEY

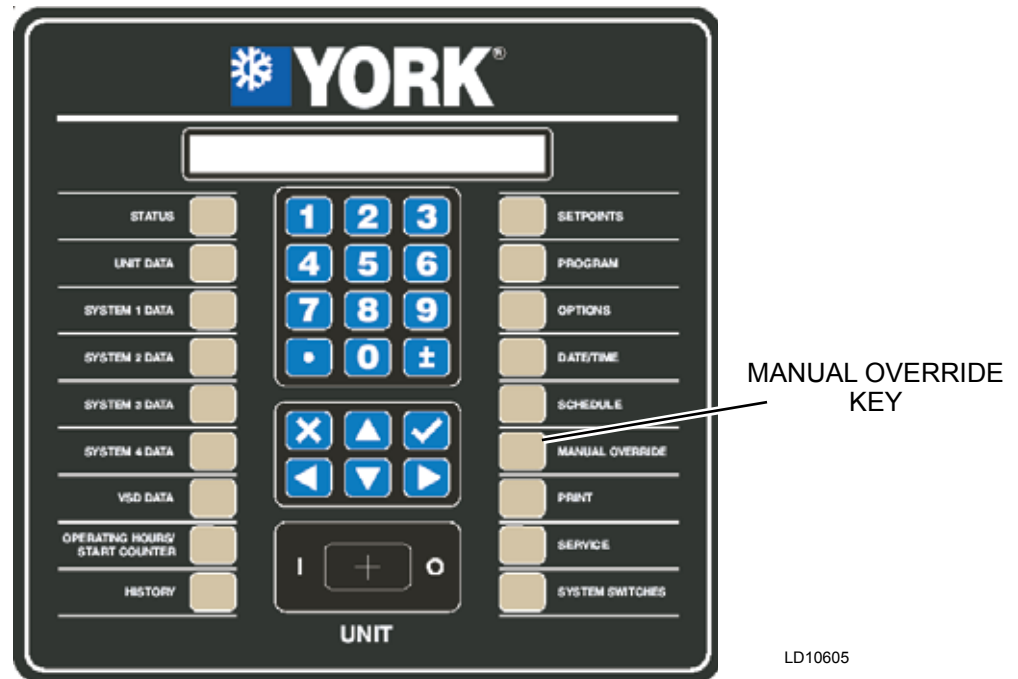

LD10605

### Manual Override Key Operation

If the MANUAL OVERRIDE key is pressed during a schedule shutdown, the STATUS display will display the message below. This indicates that the Daily Schedule is being ignored and the chiller will start when chilled liquid temperature allows, Remote Contacts, UNIT switch and SYSTEM switches permitting. This is a priority message and cannot be overridden by anti-recycle messages, fault messages, etc. when in the STATUS display mode. Therefore, do not expect to see any other STATUS messages when in the MANUAL OVERRIDE mode. MANUAL OVERRIDE is to only be used in emergencies or for servicing. Manual override mode automatically disables itself after 30 minutes.

**MANUAL OVERRIDE**

### PRINT KEY

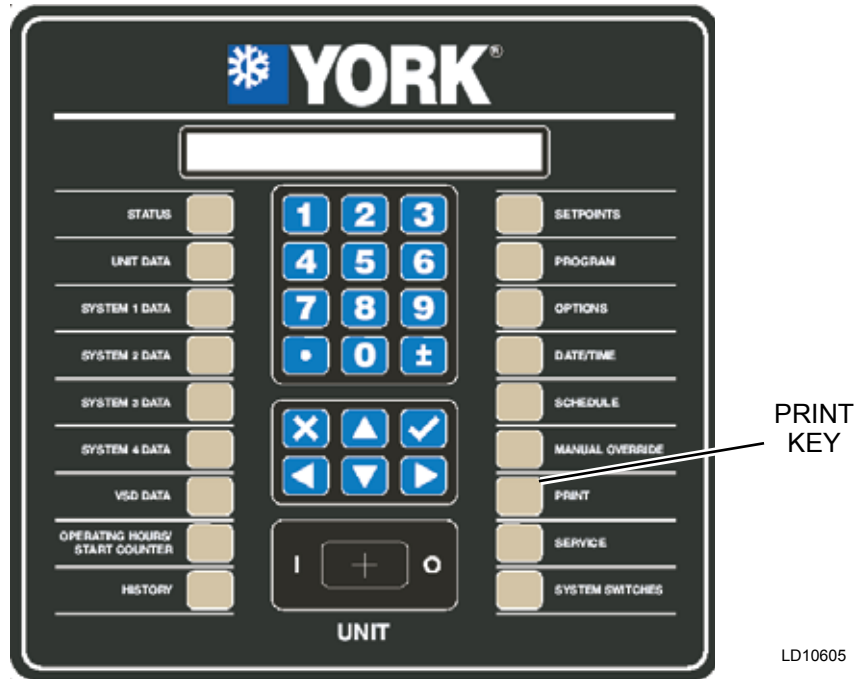

#### Print Key Operation

The PRINT key is used to initiate a printout of current operating data (real time data), a complete history printout of all history (fault) buffers, a printout of all normal shutdowns (compressor cycling, chiller shutdown, etc.) or history (fault) data printout of a specific fault. History Buffer 1 will always be the most recent fault history printout. Printing may also be canceled by selecting the CANCEL PRINTING option. The following message is displayed when the PRINT key is pressed.



After pressing the PRINT key, the printout type is selected by pressing the ◀ (LEFT ARROW) or ▶ (RIGHT ARROW) keys until the desired printout is displayed.

TABLE 18 shows the available printout types.

TABLE 18 - PRINTOUT TYPES

PRINTOUT TYPES
Operating Data (Default Selection)
All History Buffers
Normal Shutdowns
History Buffer 1
History Buffer 2
History Buffer 3
History Buffer 4
History Buffer 5
History Buffer 6
History Buffer 7
History Buffer 8
History Buffer 9
History Buffer 10
Cancel Printing

The specific printout is initiated by pressing the ✓ (ENTER) key.

A sample of the operating data printout is shown below. The operating data printout is a snapshot of current system operating conditions when the printout was selected. The sample shows combined printouts of 2, 3, and 4 circuit units. The actual printout will only show data for the appropriate chiller type.

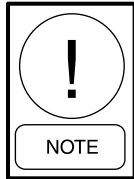

***Bold italic text below a line of print is not on the actual printout. Bold italic text indicates information that may not be available on all printouts or is additional information to help explain the difference in a 2/3 or 4-circuit printout.***

**Operating Data Printout**

```

YORK INTERNATIONAL CORPORATION
LATITUDE SCREW CHILLER

OPERATING DATA
2:04:14 PM 18 FEB 10

SYS 1
NOT RUNNING
SYS 2
COMPRESSOR RUNNING

OPTIONS
CHILLED LIQUID WATER
LOCAL/REMOTE MODE REMOTE
LEAD/LAG CONTROL AUTOMATIC
REMOTE TEMP RESET DISABLED
REMOTE CURRENT LIMIT 0 TO 10 V
REMOTE SOUND LIMIT 4 TO 20 MA
(if Sound Limiting enabled)
LOW AMBIENT CUTOUT ENABLED

PROGRAM VALUES
SUCTION PRESS CUTOUT 44 PSIG
LOW AMBIENT CUTOUT 25.0 DEGF
LEAVING LIQUID CUTOUT 36.0 DEGF
MOTOR CURRENT LIMIT 100 %FLA
PULLDOWN CURRENT LIMIT 100 %FLA
PULLDOWN LIMIT TIME 0 MIN
SUCTION SUPERHEAT SETP 12.0 DEGF
UNIT ID NUMBER 0
SOUND LIMIT SETPOINT 100%
(if Sound Limiting enabled)

UNIT DATA
LEAVING LIQUID TEMP 49.0 DEGF
RETURN LIQUID TEMP 58.2 DEGF
TEMP RATE XXX.X DEGF/MIN
COOLING RANGE 42.0+/-2.0 DEGF
REMOTE SETPOINT 44.0 DEGF
AMBIENT AIR TEMP 74.8 DEGF
LEAD SYSTEM SYS 2
FLOW SWITCH ON
EVAPORATOR PUMP RUN ON
EVAPORATOR HEATER OFF
ACTIVE REMOTE CONTROL NONE
OPERATING HOURS 1=XXXXX, 2=XXXXX
3=XXXXX
(3 circuit)
    
```

```

3=XXXXXX, 4=XXXXXX
START COUNTER 1=XXXXXX, 2=XXXXXX
3=XXXXX
(3 circuit)
3=XXXXXX, 4=XXXXXX
(4 circuit)
SOFTWARE VERSION C.ACS.XX.00

VSD DATA
ACTUAL FREQUENCY XXX.X HZ
COMMAND FREQUENCY XXX.X HZ
DC BUS VOLTAGE XXX VDC
(2 circuit & 3 circuit)
DC BUS VOLTAGES XXX XXX VDC
(4 circuit)
INTERNAL AMBIENT TEMP XXX.X DEGF
COOLING SYSTEM STATUS XXX
BASEPLATE TEMPS XXX XXX DEGF
PRECHARGE SIGNAL XXX
(2 circuit & 3 circuit)
PRECHARGE SIGNALS XXX XXX
(4 circuit)
MOTOR OVERLOADS 1/2 XXX XXX AMPS
MOTOR OVERLOADS 3/4 XXX XXX AMPS
(3 circuit & 4 circuit)
SOFTWARE VERSION C.VSD.XX.00

SYSTEM 1 DATA
COMPRESSOR STATUS OFF
RUN TIME 0- 0- 0- 0 D-H-M-S
MOTOR CURRENT 0AMPS 0 %FLA
SUCTION PRESSURE 125 PSIG
DISCHARGE PRESSURE 131 PSIG
OIL PRESSURE 130 PSIG
SUCTION TEMPERATURE 68.4 DEGF
DISCHARGE TEMPERATURE 68.8 DEGF
OIL TEMPERATURE 68.8 DEGF
SAT SUCTION TEMP 71.8 DEGF
SUCTION SUPERHEAT 3.4 DEGF
SAT DISCHARGE TEMP 74.5 DEGF
DISCHARGE SUPERHEAT 6.3 DEGF
MOTOR TMP XXX.X XXX.X XXX.X DEGF
COMPRESSOR SPEED XXX.X %
ECONOMIZER SOLENOID OFF
FLASH TANK LEVEL XXX.X %
FEED VALVE % OPEN XXX.X %
DRAIN VALVE % OPEN XXX.X %
CONDENSER FANS ON 0
COMPRESSOR HEATER ON
RUN PERMISSIVE ON
VSD RUN RELAY OFF
VSD SOFTWARE RUN SIGNAL OFF

SYSTEM 2 DATA
COMPRESSOR STATUS ON
RUN TIME 0-0-15-26 D-H-M-S
MOTOR CURRENT 104 AMPS 87 %FLA
SUCTION PRESSURE 57 PSIG
DISCHARGE PRESSURE 233 PSIG
OIL PRESSURE 218 PSIG
SUCTION TEMPERATURE 42.9 DEGF
DISCHARGE TEMPERATURE 145.5 DEGF
OIL TEMPERATURE 102.8 DEGF
SAT SUCTION TEMP 31.7 DEGF
SUCTION SUPERHEAT 11.2 DEGF
SAT DISCHARGE TEMP 112.1 DEGF
DISCHARGE SUPERHEAT 33.4 DEGF
MOTOR TMP XXX.X XXX.X XXX.X DEGF
COMPRESSOR SPEED XXX.X%
LIQUID LINE SOLENOID ON
    
```

```
FLASH TANK LEVEL          XXX.X %
FEED VALVE % OPEN        XXX.X %
DRAIN VALVE % OPEN       XXX.X %
CONDENSER FANS ON        3
COMPRESSOR HEATER        OFF
RUN PERMISSIVE            ON
VSD RUN RELAY             OFF
VSD SOFTWARE RUN SIGNAL   OFF
```

UNIT OPERATING SCHEDULE

```
S M T W T F S          *=HOLIDAY
MON START=00:00AM      STOP=00:00AM
TUE START=00:00AM      STOP=00:00AM
WED START=00:00AM      STOP=00:00AM
THU START=00:00AM      STOP=00:00AM
FRI START=00:00AM      STOP=00:00AM
SAT START=00:00AM      STOP=00:00AM
HOL START=00:00AM      STOP=00:00AM
```

SOUND LIMIT SCHEDULE

(This section is printed only if the sound limit schedule is enabled)

```
MON START=00:00AM      STOP=00:00AM
TUE START=00:00AM      STOP=00:00AM
WED START=00:00AM      STOP=00:00AM
THU START=00:00AM      STOP=00:00AM
FRI START=00:00AM      STOP=00:00AM
SAT START=00:00AM      STOP=00:00AM
HOL START=00:00AM      STOP=00:00AM
```

**History Data Printout**

History printouts, when selected, provide stored data relating to all specific system and chiller operating conditions at the time of the fault, regardless of whether a lockout occurred. History information is stored in battery-backed memory on the Chiller Control Board and is not affected by power failures or resetting of faults. Whenever a fault of any type occurs, all system operating data is stored in battery-backed memory at the instant of the fault. The history printout is similar to the operating data printout except for the change in the header information shown below:

YORK INTERNATIONAL CORPORATION  
LATITUDE SCREW CHILLER

```
HISTORY NUMBER 1
2:04:14 PM 18 FEB 10
SYS 1 YYYYYYYY
HIGH DSCH PRESS SHUTDOWN

STATUS AT TIME OF SHUTDOWN
SYS 1 XXXXXXXXXXXXXXXXXXXXXXXXXXXXXXXX
SYS 2 XXXXXXXXXXXXXXXXXXXXXXXXXXXXXXXX

ALL FAULTS
XXXXXXXXXXXXXXXXXXXXXXXXXXXXXXXXXXXXX
XXXXXXXXXXXXXXXXXXXXXXXXXXXXXXXXXXXXX
```

The most recent fault will always be stored as HISTORY BUFFER #1.

## SERVICE KEY

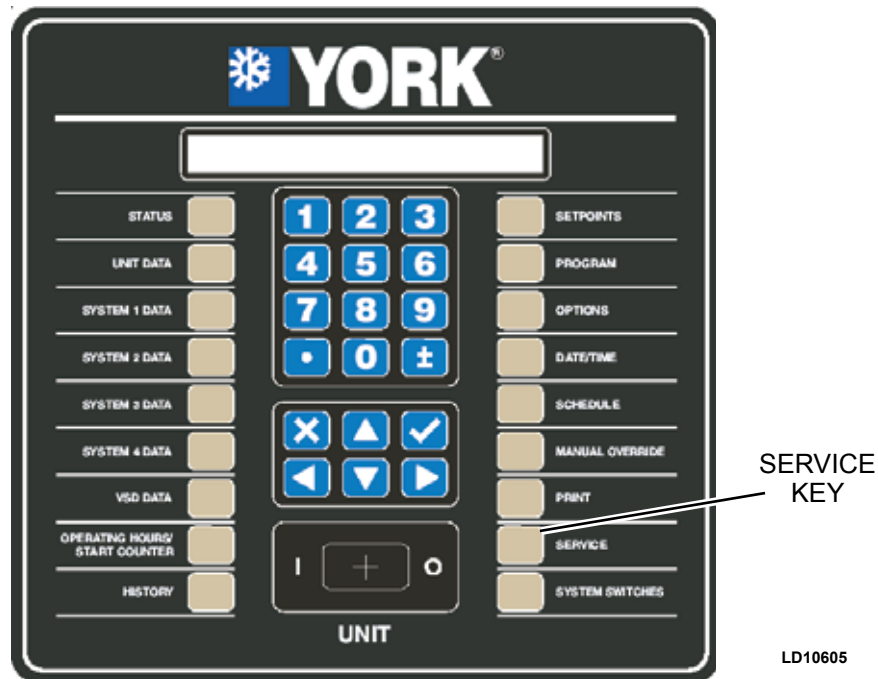

### Service Key Operation

The SERVICE key allows viewing data related to the internal function of the chiller system electronics. Data such as circuit board output status as controlled by the Chiller Control software while operating can be viewed and compared to actual chiller operation in the event servicing is required. The SERVICE key allows controlling of analog and digital outputs for troubleshooting purposes when the unit is not running. The Unit Serial Number and Optimized IPLV Control mode are also entered using the SERVICE key.

The ▲▼ (ARROW) keys allow scrolling through the displays. The ▼ (ARROW) key scrolls through the displays in the forward direction.

When the SERVICE key is pressed, the following message will appear:

**SERVICE MODE XXXX**  
**PRESS ENTER KEY TO CONTINUE**

XXXX will display a password, if a numerical password is entered.

Pressing the ✓ (ENTER) key allows “view only” Service Mode operation. All control board I/O will be

viewable in this mode. No outputs can be changed. For troubleshooting or start-up commissioning purposes, the Chiller Micro Board and some VSD outputs can be toggled or changed by turning off the UNIT SWITCH, pressing the SERVICE key, entering password 9675, and pressing the ✓ (ENTER) key. Once the password is entered, the Digital Outputs (DO) can be toggled by pressing the ✓ (ENTER) key. The Analog Outputs can be programmed to output a specific value using the keypad and programming in the desired value, which will usually be noted as a % or VDC. If the UNIT SWITCH is turned back on, the chiller will revert to normal viewable only control.

Displays can be viewed by pressing the ▲ and ▼ (ARROW) keys. The ▼ (ARROW) key scrolls through the displays in the forward direction.

The ◀ and ▶ (ARROW) keys allow jumping from data section to data section to avoid scrolling sequentially through all the data. Once in a data section, the ▲ and ▼ (ARROW) keys allow scrolling through the data under the section. Pressing the ◀ and ▶ (ARROW) keys at any time moves to the top of the next data section.

The data sections are listed below:

- Software Versions
- Analog Inputs
- Digital Inputs
- Digital Outputs
- Analog Outputs
- VSD Logic Digital Output

**SERVICE SOFTWARE VERSIONS**  
**CONTROL = C.AXX.ZZ.YY VSD = C.VXX.ZZ.YY**

The software version of the chiller Micro Control Board and the VSD microprocessor are viewable in the first data section.

XX, YY, and ZZ will be filled in with alphanumeric characters.

The second data section displays the Analog Inputs (AI). Displays for 3 and 4 compressor chillers are skipped if the unit does not have those systems. These messages will only be displayed in English. The voltage displayed is referenced to common (return, ground) in the system. J12-3 can also be used as common, as well as chassis ground, or the common terminal point on the Chiller Control Board. *See the wiring diagrams.*

**SERVICE AI J17-11 REMOTE TEMP RESET**  
**X.X VDC = XXX.X %**

**SERVICE AI J17-12 REMOTE CURRENT LIMIT**  
**X.X VDC = XXX.X %**

**SERVICE AI J17-13 REMOTE SOUND LIMIT**  
**X.X VDC = XXX.X %**

The Remote Temp Reset, Remote Current Limit Reset, and Remote Sound Limit inputs have onboard voltage dividers, if the jumper is set for a voltage input. This will cause the voltage read on the display to be less than the voltage on the board header inputs between TB1-17 and 18, TB1-19 and 20, or TB1-40 and 41). To correct for this when measuring voltage at the remote device supplying voltage to the board header while troubleshooting, use the following calculation:

$$\text{Voltage} = 10 \times \text{VDC volts} / 4.5$$

If the input is programmed for a current input, the voltage read by the MUX is displayed. If the input is disabled under the OPTIONS key, the voltage display will display “DISABLED”.

The analog inputs display will continue to sequence as follows. The inputs indicate voltages read between the input terminal to the Chiller Logic Board and the plug GND or Drain.

**SERVICE AI J17-14 SPARE ANALOG 1**  
**X.X VDC**

**SERVICE AI J17-15 SPARE ANALOG 2**  
**X.X VDC**

**SERVICE AI J18-7 LEAVING LIQUID TEMP**  
**X.X VDC = XXX.X °F**

**SERVICE AI J18-8 RETURN LIQUID TEMP**  
**X.X VDC = XXX.X °F**

**SERVICE AI J18-9 AMBIENT AIR TEMP**  
**X.X VDC = XXX.X °F**

**SERVICE AI J19-1 SYS1 MOTOR TEMP T1**  
**X.X VDC = XXX.X °F**

**SERVICE AI J19-2 SYS1 MOTOR TEMP T2**  
**X.X VDC = XXX.X °F**

**SERVICE AI J19-3 SYS1 MOTOR TEMP T3**  
**X.X VDC = XXX.X °F**

**SERVICE AI J19-6 SYS2 MOTOR TEMP T1**  
**X.X VDC = XXX.X °F**

**SERVICE AI J19-7 SYS2 MOTOR TEMP T2**  
**X.X VDC = XXX.X °F**

**SERVICE AI J19-8 SYS2 MOTOR TEMP T3**  
**X.X VDC = XXX.X °F**

**SERVICE AI J20-1 SYS3 MOTOR TEMP T1**  
**X.X VDC = XXX.X °F**

**SERVICE AI J20-2 SYS3 MOTOR TEMP T2**  
**X.X VDC = XXX.X °F**

SERVICE AI J20-3 SYS3 MOTOR TEMP T3  
X.X VDC = XXX.X °F

SERVICE AI J20-6 SYS4 MOTOR TEMP T1  
X.X VDC = XXX.X °F

SERVICE AI J20-7 SYS4 MOTOR TEMP T2  
X.X VDC = XXX.X °F

SERVICE AI J20-8 SYS4 MOTOR TEMP T3  
X.X VDC = XXX.X °F

SERVICE AI J21-3 SYS1 OIL TEMP  
X.X VDC = XXX.X °F

SERVICE AI J21-6 SYS1 FL TANK LEVEL  
X.X VDC = XXX.X %

SERVICE AI J21-13 SYS1 SUCTION TEMP  
X.X VDC = XXX.X °F

SERVICE AI J21-16 SYS1 DISCHARGE TEMP  
X.X VDC = XXX.X °F

SERVICE AI J21-20 SYS1 SUCTION PRESS  
X.X VDC = XXX.X PSIG

SERVICE AI J21-22 SYS1 OIL PRESS  
X.X VDC = XXX.X PSIG

SERVICE AI J21-24 SYS1 DISCHARGE PRESS  
X.X VDC = XXX.X PSIG

SERVICE AI J22-3 SYS2 OIL TEMP  
X.X VDC = XXX.X °F

SERVICE AI J22-6 SYS2 FL TANK LEVEL  
X.X VDC = XXX.X %

SERVICE AI J22-13 SYS2 SUCTION TEMP  
X.X VDC = XXX.X °F

SERVICE AI J22-16 SYS2 DISCHARGE TEMP  
X.X VDC = XXX.X °F

SERVICE AI J22-20 SYS2 SUCTION PRESS  
X.X VDC = XXX.X PSIG

SERVICE AI J22-22 SYS2 OIL PRESS  
X.X VDC = XXX.X PSIG

SERVICE AI J22-24 SYS2 DISCHARGE PRESS  
X.X VDC = XXX.X PSIG

SERVICE AI J23-3 SYS3 OIL TEMP  
X.X VDC = XXX.X °F

SERVICE AI J23-6 SYS3 FL TANK LEVEL  
X.X VDC = XXX.X %

SERVICE AI J23-13 SYS3 SUCTION TEMP  
X.X VDC = XXX.X °F

SERVICE AI J23-16 SYS3 DISCHARGE TEMP  
X.X VDC = XXX.X °F

SERVICE AI J23-20 SYS3 SUCTION PRESS  
X.X VDC = XXX.X PSIG

SERVICE AI J23-22 SYS3 OIL PRESS  
X.X VDC = XXX.X PSIG

SERVICE AI J23-24 SYS3 DISCHARGE PRESS  
X.X VDC = XXX.X PSIG

SERVICE AI J24-3 SYS4 OIL TEMP  
X.X VDC = XXX.X °F

SERVICE AI J24-6 SYS4 FL TANK LEVEL  
X.X VDC = XXX.X %

SERVICE AI J24-13 SYS4 SUCTION TEMP  
X.X VDC = XXX.X °F

SERVICE AI J24-16 SYS4 DISCHARGE TEMP  
X.X VDC = XXX.X °F

SERVICE AI J24-20 SYS4 SUCTION PRESS  
X.X VDC = XXX.X PSIG

SERVICE AI J24-22 SYS4 OIL PRESS  
X.X VDC = XXX.X PSIG

SERVICE AI J24-24 SYS4 DISCHARGE PRESS  
X.X VDC = XXX.X PSIG

The third data section displays the Digital Inputs (DI) to the Chiller Control Board that can be viewed from the Service Mode. Displays for systems 3 and 4 are skipped if the systems are not present on the chiller. XXX is replaced with ON or OFF in the actual display. These messages will only be displayed in English.

**SERVICE DI J4-2                    UNIT SWITCH 1  
STATUS = XXX**

**SERVICE DI J4-3                    UNIT SWITCH 2  
STATUS = XXX**

**SERVICE DI J4-4                    SYS 1 HPCO  
STATUS = XXX**

**SERVICE DI J4-5                    SYS 2 HPCO  
STATUS = XXX**

**SERVICE DI J4-6                    VSD FAULT RELAY  
STATUS = XXX**

**SERVICE DI J5-1                    SYS 3 HPCO  
STATUS = XXX**

**SERVICE DI J5-2                    SYS 4 HPCO  
STATUS = XXX**

**SERVICE DI J5-3                    SPARE DIGITAL INPUT 2  
STATUS = XXX**

J5 is not present on a 2 compressor Chiller Control Board. The displays above are skipped for a 2 compressor chiller:

**SERVICE DI J6-2                    FLOW SWITCH  
STATUS = XXX**

**SERVICE DI J6-3                    PRINT  
STATUS = XXX**

**SERVICE DI J6-4                    SYS 1/3 RUN PERM  
STATUS = XXX**

**SERVICE DI J6-5                    SYS 2/4 RUN PERM  
STATUS = XXX**

**SERVICE DI J6-6                    SPARE DIGITAL INPUT 1  
STATUS = XXX**

**SERVICE DI J7-2                    CONFIG INPUT 0  
STATUS = XXX**

**SERVICE DI J7-4                    CONFIG INPUT 1  
STATUS = XXX**

**SERVICE DI J7-6                    CONFIG INPUT 2  
STATUS = XXX**

**SERVICE DI J7-8                    CONFIG INPUT 3  
STATUS = XXX**

**SERVICE DI J7-10                  CONFIG SPARE INPUT 0  
STATUS = XXX**

**SERVICE DI J7-12                  CONFIG SPARE INPUT 1  
STATUS = XXX**

**SERVICE DO J9-1                    EVAP HEATER  
RB1 TB1-20                    STATUS = XXX**

**SERVICE DO J9-2                    SYS 1/3 VSD RUN  
RB1 TB1-18                    STATUS = XXX**

**SERVICE DO J9-3                    SYS 1/3 ALARM  
RB1 TB1-16                    STATUS = XXX**

**SERVICE DO J9-4                    EVAP HEATER 2  
RB1 TB1-14                    STATUS = XXX**

**SERVICE DO J9-5                    SYS 1 SPARE  
RB1 TB1-12                    STATUS = XXX**

**SERVICE DO J9-6                    SPARE 1  
RB1 TB1-10                    STATUS = XXX**

**SERVICE DO J9-7                    SPARE 2  
RB1 TB1-8                    STATUS = XXX**

**SERVICE DO J9-8                    SYS 1 COND FAN OUT 1  
RB1 TB1-6                    STATUS = XXX**

**SERVICE DO J9-9                    SYS 1 COND FAN OUT 2  
RB1 TB1-5                    STATUS = XXX**

**SERVICE DO J9-10                  SYS 1 COND FAN OUT 3  
RB1 TB1-4                    STATUS = XXX**

**SERVICE DO J9-11                  SYS 1 COMP HEATER  
RB1 TB1-3                    STATUS = XXX**

**SERVICE DO J9-10                  SYS 1 ECON SOL VALVE  
RB1 TB1-2                    STATUS = XXX**

SERVICE DO J10-1 RB1 TB1-20	EVAP PUMP RUN STATUS = XXX
SERVICE DO J10-2 RB1 TB1-18	SYS 2/4 VSD RUN STATUS = XXX
SERVICE DO J10-3 RB1 TB1-16	SYS 2/4 ALARM STATUS = XXX
SERVICE DO J10-4 RB1 TB1-14	CHILLER RUN STATUS = XXX
SERVICE DO J10-5 RB1 TB1-12	SYS 2 SPARE STATUS = XXX
SERVICE DO J10-6 RB1 TB1-10	SPARE 3 STATUS = XXX
SERVICE DO J10-7 RB1 TB1-8	SPARE 4 STATUS = XXX
SERVICE DO J10-8 RB1 TB1-6	SYS COND 2 FAN OUT 1 STATUS = XXX
SERVICE DO J10-9 RB1 TB1-5	SYS COND 2 FAN OUT 2 STATUS = XXX
SERVICE DO J10-10 RB1 TB1-4	SYS COND 2 FAN OUT 3 STATUS = XXX
SERVICE DO J10-11 RB1 TB1-3	SYS 2 COMP HEATER STATUS = XXX
SERVICE DO J10-12 RB1 TB1-2	SYS 2 ECON SOL VALVE STATUS = XXX
SERVICE DO J11-1 RB1 TB1-20	SYS 4 COND FAN OUT 1 STATUS = XXX
SERVICE DO J11-2 RB1 TB1-18	SYS 4 COND FAN OUT 2 STATUS = XXX
SERVICE DO J11-3 RB1 TB1-16	SYS 4 COND FAN OUT 3 STATUS = XXX
SERVICE DO J11-4 RB1 TB1-14	SYS 4 COMP HEATER STATUS = XXX
SERVICE DO J11-5 RB1 TB1-12	SYS 4 ECON SOL VALVE STATUS = XXX

SERVICE DO J11-6 RB1 TB1-10	SYS 4 SPARE STATUS = XXX
SERVICE DO J11-7 RB1 TB1-8	SYS 3 SPARE STATUS = XXX
SERVICE DO J11-8 RB1 TB1-6	SYS 3 COND FAN OUT 1 STATUS = XXX
SERVICE DO J11-9 RB1 TB1-5	SYS 3 COND FAN OUT 2 STATUS = XXX
SERVICE DO J11-10 RB1 TB1-4	SYS 3 COND FAN OUT 3 STATUS = XXX
SERVICE DO J11-11 RB1 TB1-3	SYS 3 COMP HEATER STATUS = XXX
SERVICE DO J11-12 RB1 TB1-2	SYS 3 ECON SOL VALVE STATUS = XXX

8

The fifth data section displays the Analog Outputs (AO) that can be viewed from the Service Mode. The Analog Output signals are typically referenced to the common (return, ground) in the system. J12-3 can also be used as common, as well as chassis ground, or the common terminal point on the Chiller Control Board. *See the wiring diagrams.* GND on the plug. Displays for systems 3 and 4 are skipped if the systems are not present on the chiller. XXX is replaced with ON or OFF in the actual display. The state of these outputs is only viewable unless the password 9675 ✓(ENTER) key was entered from the initial Service Mode display with the UNIT switch in the OFF position. The chiller will not be permitted to run when the outputs are made active. The outputs can be programmed for a specific % output by keying in the value and pressing the ✓(ENTER) key. These messages will only be displayed in English.

SERVICE AO J15-1 XXX.X %	SYS 1 FEED VALVE OUT = XX.X VDC
SERVICE AO J15-3 XXX.X %	SYS 1 DRAIN VALVE OUT = XX.X VDC
SERVICE AO J15-5 XXX.X %	SYS 2 FEED VALVE OUT = XX.X VDC
SERVICE AO J15-7 XXX.X %	SYS 2 DRAIN VALVE OUT = XX.X VDC

<b>SERVICE AO J14-1</b>	<b>SYS 3 FEED VALVE OUT</b>
<b>XXX.X %</b>	<b>= XX.X VDC</b>

<b>SERVICE AO J14-2</b>	<b>SYS 3 DRAIN VALVE OUT</b>
<b>XXX.X %</b>	<b>= XX.X VDC</b>

<b>SERVICE AO J14-3</b>	<b>SYS 4 FEED VALVE OUT</b>
<b>XXX.X %</b>	<b>= XX.X VDC</b>

<b>SERVICE AO J14-4</b>	<b>SYS 4 DRAIN VALVE OUT</b>
<b>XXX.X %</b>	<b>= XX.X VDC</b>

<b>SERVICE AO J25-1</b>	<b>SYS 1 SPARE</b>
<b>XXX.X %</b>	<b>= XX.X VDC</b>

<b>SERVICE AO J25-2</b>	<b>SYS 2 SPARE</b>
<b>XXX.X %</b>	<b>= XX.X VDC</b>

<b>SERVICE AO J25-3</b>	<b>SYS 3 SPARE</b>
<b>XXX.X %</b>	<b>= XX.X VDC</b>

<b>SERVICE AO J25-4</b>	<b>SYS 4 SPARE</b>
<b>XXX.X %</b>	<b>= XX.X VDC</b>

The sixth data section displays the “VSD” digital outputs (DO) that can be viewed from the Service Mode. The Digital Output signals indicate the status of the output. The 0 to 120VAC digital outputs are referenced to neutral (Wire 2).

<b>SERVICE DO J10-2</b>	<b>VSD COOLING FAN/PUMP</b>
<b>VSD LOGIC</b>	<b>STATUS = XXX</b>

## SYSTEM SWITCHES KEY

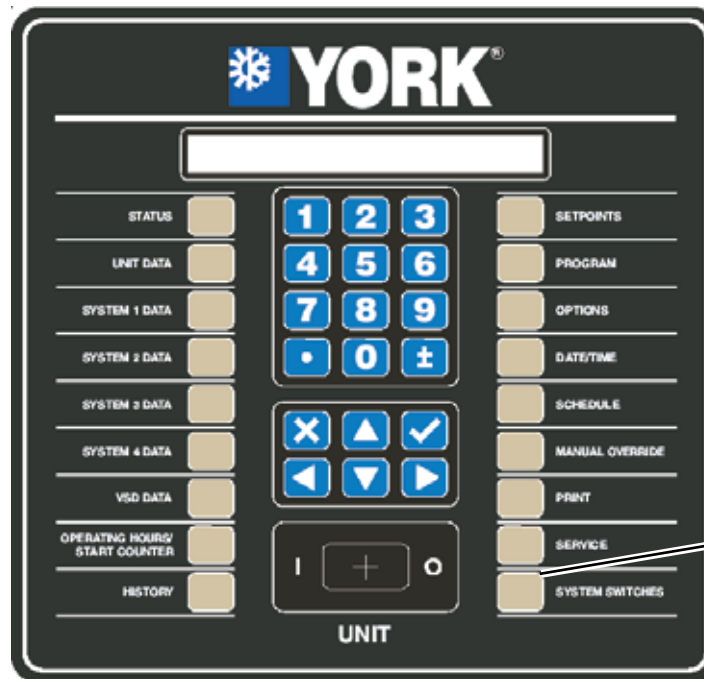

SYSTEM SWITCHES KEY

LD10605

### System Switches Key Operation

The SYSTEM SWITCHES key allows the operator to turn individual systems ON and OFF. Safety lock-outs are also reset by selecting the respective system switch RESET. When the SYSTEM SWITCHES key is pressed, the following message will appear:

```
SYSTEM SWITCHES  SYS 1 ON / OFF / RESET
◀▶              =XXXXXXXXXXXXXXXXXX
```

The display indicates the respective system and it's on/off /reset switch status. The ▲ ▼ (ARROW) keys allow scrolling to the next and previous system switch (System 1, 2, 3, or 4).

```
SYSTEM SWITCHES  SYS 2 ON / OFF / RESET
◀▶              =XXXXXXXXXXXXXXXXXX
```

```
SYSTEM SWITCHES  SYS 3 ON / OFF / RESET
◀▶              =XXXXXXXXXXXXXXXXXX
```

```
SYSTEM SWITCHES  SYS 4 ON / OFF / RESET
◀▶              =XXXXXXXXXXXXXXXXXX
```

The ◀ (LEFT ARROW) or ▶ (RIGHT ARROW) keys allow scrolling through the choices of:

- SYSTEM OFF (default)
- SYSTEM ON
- RESET (LOCKOUT)

The switch selection is accepted into memory by pressing the ✓ (ENTER) key.

When the "RESET" selection is made and accepted, it will not change the position of the switch (either ON or OFF).

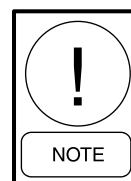

*Whenever possible, except in emergencies, always use the associated system switch to turn off a compressor, which allows the compressors to go through a controlled shutdown. Avoid using the "UNIT" switch to turn off the compressors.*

## SERIAL NUMBER PROGRAMMING

When changing a Chiller Control Board, a Chiller Control Board EPROM, or if a situation occurs where a chiller is not programmed from the factory, the chiller serial number will need to be programmed into the chiller. The serial number is the actual serial number displayed on the unit Data Plate. The serial number will be in a format similar to RABM000000, where the first 4 characters are letters and the next 6 are numbers. The lack of a serial number programmed into the panel will not prevent a chiller from operating, but a High IPLV chiller will only operate in the Standard IPLV mode. The STATUS display will inform the operator a serial number problem exists by displaying the following message:

```
UNIT WARNING:      INVALID SERIAL NUMBER
ENTER UNIT SERIAL NUMBER
```

If the following message appears, immediately contact Johnson Controls Product Technical Support. The appearance of this message may also mean the chiller has lost important factory programmed information and may need to be reprogrammed. Additional STATUS messages can be viewed by pressing the STATUS key repetitively to enable the technician to view any other messages that may be preventing the chiller from operating.

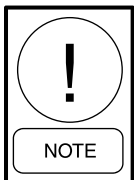

***Changing the programming of this feature requires the date and time to be set on the chiller prior to programming. The password is also time sensitive and must be used the same day it is received.***

Johnson Controls Product Technical Support will provide a factory password to allow programming the serial number into the chiller. You will need to supply Factory Technical Support with the version of the Chiller Control Board EPROM. The version will be written on the EPROM label and typically will be in the format Version C.ACS.XX.XX.

After obtaining the password, the following steps will need to be followed to input the serial number. As the serial number is input, the characters keyed in will appear in the display indicating the panel has recognized the entry.

First press the SERVICE key. The following message will appear:

```
SERVICE MODE      XXXXX
PRESS ENTER KEY TO CONTINUE
```

Key in the 5 digit alphanumeric password provided by Product Technical Support and press the ✓ (ENTER) key. The following display will appear:

```
S/N ENTRY      UNIT SERIAL NUMBER POS 1
◀ ▶           X
```

Key in the first letter (A through Z) of the serial number using the ◀ and ▶ (ARROW) keys and press the ✓ (ENTER) key. Press the ▼ (DOWN ARROW) key to scroll to position 2 and the following message will appear:

```
S/N ENTRY      UNIT SERIAL NUMBER POS 2
◀ ▶           XX
```

Key in the second letter (A through N) of the serial number using the ◀ and ▶ (ARROW) keys and press the ✓ (ENTER) key. Press the ▼ (DOWN ARROW) key to scroll to position 3 and the following message will appear:

```
S/N ENTRY      UNIT SERIAL NUMBER POS 3
◀ ▶           XXX
```

Key in the third letter (A through Z) of the serial number using the ◀ and ▶ (ARROW) keys and press the ✓ (ENTER) key. Press the ▼ (DOWN ARROW) key to scroll to position 4 and the following message will appear:

```
S/N ENTRY      UNIT SERIAL NUMBER POS 4
◀ ▶           XXXX
```

Key in the fourth letter (A through Z) of the serial number using the ◀ and ▶ (ARROW) keys and press the ✓ (ENTER) key. Press the ▼ (DOWN ARROW) key to scroll to positions 5-7 and the following message will appear:

```
S/N ENTRY UNIT S/N = YYYY XXX ZZZ
UNIT SERIAL NUMBER POS 5-7 = XXX
```

At this point, the letters entered for the YYYY inputs should now appear in the top line of the display and should match the first 4 characters of the serial number on the unit Data Plate. The next three digits of the serial number should now be keyed in. Press the ✓ (ENTER) key to store the input. Press the ▼ (DOWN ARROW) key to scroll to positions 8 through 10 and the following message will appear:

**S/N ENTRY UNIT S/N = YYYY XXX ZZZ  
UNIT SERIAL NUMBER POS 8-10 = XXX**

At this point, the letters entered for the YYYY and XXX inputs should now appear in the top line of the display and should match the first 7 characters of the serial number on the unit Data Plate. The next three digits of the serial number should now be keyed in. Press the ✓ (ENTER) key to store the input. The full serial number should now be displayed across the top of the display and the cursor should disappear.

Press the STATUS key to go to the next STATUS display to determine if additional Status messages are preventing the chiller from operating.

### ENABLING OPTIMIZED HIGH IPLV MODE

When changing a Chiller Control Board, a Chiller Control Board EPROM, or if a situation occurs where a chiller is not programmed from the factory, the chiller will not be capable of operating High IPLV mode. The serial number of the unit will first need to be programmed into the panel, if the Invalid Serial Number display appears (see Page 292). The Invalid Serial Number message will override the Optimized Efficiency Disabled message. If the chiller was purchased with the High IPLV Option and does not have the High IPLV mode enabled, it will not prevent the chiller from operating, but the chiller will only operate in the Standard IPLV mode. Additional STATUS messages can be viewed by pressing the STATUS key repetitively to enable the technician to view any other messages that may be preventing the chiller from operating.

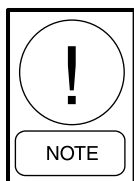

*Changing the programming of this feature requires the date and time to be set on the chiller prior to programming the password. The password is also time sensitive and must be used “immediately” when it is received.*

The STATUS display will inform the operator when a High IPLV chiller is operating with the High IPLV mode disabled by displaying the following STATUS message:

**UNIT WARNING: OPTIMIZED EFFICIENCY  
DISABLED - CONTACT YORK REPRESENTATIVE**

If the message above appears, immediately contact Johnson Controls Product Technical Support or Johnson Controls ES Commercial for a password to enable the High IPLV mode. You will need to provide Johnson Controls Product Technical Support or Johnson Controls ES Commercial with the Unit Serial Number located on the chiller nameplate. The date and time will also need to be current on the chiller, and will need to be provided to Johnson Controls Product Technical Support or Johnson Controls ES Commercial. It is essential Johnson Controls Product Technical Support or, Johnson Controls ES Commercial is aware of the “local” time to allow adjustments for time differences from Eastern Standard Time.

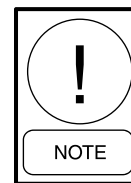

*After obtaining the password, the following steps will need to be carried out “immediately” to input the serial number. If the password is not immediately input, the panel will not accept it.*

To enable HIGH IPLV Mode, first press the SERVICE key. The following message will appear:

**SERVICE MODE XXXXX  
PRESS ENTER KEY TO CONTINUE**

Key in the 6 digit alphanumeric password provided by Johnson Controls Technical Support or Johnson Controls ES Commercial and press the ✓ (ENTER) key. The following display will appear:

**IPLV OPTIMIZED EFFICIENCY CONTROL  
◀▶XXXXXXXXXXXXXXXXXXXXXXXXXXXX**

When the Optimized (High IPLV) is enabled, the display will indicate, “ENABLED”. When not enabled, the display will indicate, “DISABLED”. Use the ◀ and ▶ (ARROW) keys to enable/disable and press the ✓ (ENTER) key to store the selection.

**UNIT SETUP MODE**

Unit Setup Mode will allow the programming all of the programmable values that the user should never change. These will either be programmed at the factory or by service personnel on the job.

This mode may be entered by pressing the PROGRAM key, entering the password 4245, and pressing the ✓(ENTER) key. TABLE 19 lists the values that can be programmed in this mode. Details relating to the actual message follow the table.

**TABLE 19 - UNIT SETUP PROGRAMMABLE VALUES**

SETUP MODE VALUE	PROGRAMMABLE RANGE	DEFAULT
Sys 1 Number of Cond Fans	4 to 6	6
Sys 2 Number of Cond Fans	4 to 6	6
Sys 3 Number of Cond Fans	4 to 6	6
Sys 4 Number of Cond Fans	4 to 6	6
Compressor 1 Operating hours	0 to 99,999	0
Compressor 2 Operating hours	0 to 99,999	0
Compressor 3 Operating hours	0 to 99,999	0
Compressor 4 Operating hours	0 to 99,999	0
Compressor 1 Starts	0 to 99,999	0
Compressor 2 Starts	0 to 99,999	0
Compressor 3 Starts	0 to 99,999	0
Compressor 4 Starts	0 to 99,999	0
Clear History Buffers	Yes/ No	-
Remote Temp Reset Option	Disabled/Enabled	Disabled
Remote Current Limit Option	Disabled/Enabled	Disabled
Sound Limit Option	Disabled/Enabled	Disabled
Remote Inputs Service Time	5 Min - 60 Min	15 Min
Sys 1 Motor Sensor to Ignore	See Below	None
Sys 2 Motor Sensor to Ignore	See Below	None
Sys 3 Motor Sensor to Ignore	See Below	None
Sys 4 Motor Sensor to Ignore	See Below	None

The following messages will be displayed for the Unit Setup Mode in the order they appear. The first group of displays relates to setup parameters that relate to unit configuration and factory setpoints.

**SETUP MODE ◀ DEF XXXXX LO XXXXX HI XXXXX  
SYS 1 NUMBER OF COND FANS = X**

**SETUP MODE ◀ DEF XXXXX LO XXXXX HI XXXXX  
COMP 1 OPERATING HOURS = XXXXX**

**SETUP MODE ◀ DEF XXXXX LO XXXXX HI XXXXX  
SYS 2 NUMBER OF COND FANS = X**

**SETUP MODE ◀ DEF XXXXX LO XXXXX HI XXXXX  
COMP 2 OPERATING HOURS = XXXXX**

**SETUP MODE ◀ DEF XXXXX LO XXXXX HI XXXXX  
SYS 3 NUMBER OF COND FANS = X**

**SETUP MODE ◀ DEF XXXXX LO XXXXX HI XXXXX  
COMP 3 OPERATING HOURS = XXXXX**

**SETUP MODE ◀ DEF XXXXX LO XXXXX HI XXXXX  
SYS 4 NUMBER OF COND FANS = X**

**SETUP MODE ◀ DEF XXXXX LO XXXXX HI XXXXX  
COMP 4 OPERATING HOURS = XXXXX**

SETUP MODE ◀ DEF XXXXX LO XXXXX HI XXXXX  
COMP 1 STARTS = XXXXX

SETUP MODE ◀ DEF XXXXX LO XXXXX HI XXXXX  
COMP 2 STARTS = XXXXX

SETUP MODE ◀ DEF XXXXX LO XXXXX HI XXXXX  
COMP 3 STARTS = XXXXX

SETUP MODE ◀ DEF XXXXX LO XXXXX HI XXXXX  
COMP 4 STARTS = XXXXX

The following setup display is selectable as YES or NO using the ◀ and ▶ (ARROW) keys.

SETUP MODE CLEAR HISTORY BUFFERS?  
◀ ▶ XXXXXXXXXXXXXXXXXXXXXXXXXXXXXXX

The following (3) setup OPTION displays are selectable as ENABLED or DISABLED using the ◀ and ▶ (ARROW) keys according to the options installed on the chiller:

SETUP MODE REMOTE TEMP RESET OPTION  
◀ ▶ XXXXXXXXXXXXXXXXXXXXXXXXXXXXXXX

SETUP MODE REMOTE CURRENT LIMIT OPTION  
◀ ▶ XXXXXXXXXXXXXXXXXXXXXXXXXXXXXXX

SETUP MODE SOUND LIMIT OPTION  
◀ ▶ XXXXXXXXXXXXXXXXXXXXXXXXXXXXXXX

The following setup OPTION display is selectable as ENABLED or DISABLED using the ◀ and ▶ (ARROW) keys:

SETUP MODE ◀ DEF XXXXX LO XXXXX HI XXXXX  
REMOTE INPUTS SERVICE TIME = XX MIN

The following OPTION displays are selectable as ENABLED or DISABLED using the ◀ and ▶ (ARROW) keys. The choices are:

- NONE (default)
- TEMP SENSOR 1
- TEMP SENSOR 2
- TEMP SENSOR 3

SETUP MODE SYS 1 MOTOR SENSOR TO IGNORE  
◀ ▶ XXXXXXXXXXXXXXXXXXXXXXXXXXXXXXX

SETUP MODE SYS 2 MOTOR SENSOR TO IGNORE  
◀ ▶ XXXXXXXXXXXXXXXXXXXXXXXXXXXXXXX

SETUP MODE SYS 3 MOTOR SENSOR TO IGNORE  
◀ ▶ XXXXXXXXXXXXXXXXXXXXXXXXXXXXXXX

SETUP MODE SYS 4 MOTOR SENSOR TO IGNORE  
◀ ▶ XXXXXXXXXXXXXXXXXXXXXXXXXXXXXXX

If a motor temperature sensor fails, a single sensor may be ignored by making a program change in the Unit Setup Mode. The default setting is “NONE”, indicating all sensors are being monitored.

### DEFAULT PROGRAMMABLE VALUES

To quickly program or reset most of the user programmable values to their default values, press PROGRAM, 6140, ENTER. The following message will then be displayed, allowing a choice to reset the operating parameters to their default values.

DEFAULTS SET PROG VALUES TO DEFAULT?  
◀ ▶ XXX

YES or NO may be selected for XXX using the ◀ and ▶ (ARROW) keys to change the selection.

Following is a list of the operating parameters that will be reset to their default values:

- Suction Pressure Cutout = 24.0 PSIG
- Low Ambient Air Temp Cutout = 25°F
- Leaving Chilled Liquid Temp Cutout = 36°F
- High Motor Current Limit = 100%
- Pulldown Current Limit = 100%
- Pulldown Current Limit Time = 0 Min.
- Suction Superheat Setpoint = 10°F
- Sound limit Setpoint = 0%

### SERIAL PORT CONNECTIONS

TABLE 20 lists the serial ports and the circuit board they are located on. The serial communications lines provide communications to external devices outside the chiller and between microprocessors located in the chiller control panel.

TB2 allows connecting to a remote OptiView RCC or Microgateway. The OptiView RCC option is not yet available. The OptiView RCC and Microgateway option cannot both be used. Only one or the other is permitted to be connected to the chiller.

TABLE 20 - SERIAL PORT CONNECTIONS

BOARD	HEADER	PORT TYPE	PORT USE
Chiller Control Board	TB1 / TB2	RS-232 / RS-485	Printer/RCC and ISN
Chiller Control Board	J2 / J1	RS-485	Control Panel <-> VSD #1 / #2
VSD Logic Board	J12	Opto- Coupled RS-485	VSD <-> Control Panel

## ANALOG INPUT CONNECTIONS

TABLE 21 lists the Analog inputs and the circuit board they are located on. Not all of the sensors are installed in every unit, as some of them are optional. The software must read the optional sensors if installed. The Analog input signals are typically referenced to the common (return, ground) in the system.

J12-3 can also be used as common, as well as chassis ground, or the common terminal point on the Chiller Control Board. *See the wiring diagrams.* The +DC Bus, -DC Bus and ½ DC Bus voltages are measured in reference to one of the other DC Bus points. For example: +DC Bus measured to ½ DC Bus.

TABLE 21 - ANALOG INPUT CONNECTIONS

BOARD	HEADER	ANALOG INPUT
Chiller Control Board	J17-11	Remote Temperature Reset
Chiller Control Board	J17-12	Remote Current Limit
Chiller Control Board	J17-13	Spare 1
Chiller Control Board	J17-14	Spare 2
Chiller Control Board	J17-15	Spare 3
Chiller Control Board	J8-7	Leaving Chilled Liquid Temp Sensor
Chiller Control Board	J8-8	Return Chilled Liquid Temp Sensor
Chiller Control Board	J8-9	Ambient Air Temp Sensor
Chiller Control Board	J19-1	Comp 1 Motor Temperature 1
Chiller Control Board	J19-2	Comp 1 Motor Temperature 2
Chiller Control Board	J19-3	Comp 1 Motor Temperature 3
Chiller Control Board	J19-6	Comp 2 Motor Temperature 1
Chiller Control Board	J19-7	Comp 2 Motor Temperature 2
Chiller Control Board	J19-8	Comp 2 Motor Temperature 3
Chiller Control Board	J21-13	Sys 1 Suction Temperature
Chiller Control Board	J21-3	Sys 1 Oil Temperature
Chiller Control Board	J21-16	Sys 1 Discharge Temperature
Chiller Control Board	J21-6	Sys 1 Flash Tank Level Sensor
Chiller Control Board	J21-20	Sys 1 Suction Pressure
Chiller Control Board	J21-22	Sys 1 Oil Pressure
Chiller Control Board	J21-24	Sys 1 Discharge Pressure
Chiller Control Board	J22-13	Sys 2 Suction Temperature
Chiller Control Board	J22-2	Sys 2 Oil Temperature
Chiller Control Board	J22-16	Sys 2 Discharge Temperature
Chiller Control Board	J22-6	Sys 2 Flash Tank Level Sensor
Chiller Control Board	J22-20	Sys 2 Suction Pressure
Chiller Control Board	J22-22	Sys 2 Oil Pressure
Chiller Control Board	J22-24	Sys 2 Discharge Pressure
Chiller Control Board	J20-1	Comp 3 Motor Temperature 1
Chiller Control Board	J20-2	Comp 3 Motor Temperature 2
Chiller Control Board	J20-3	Comp 3 Motor Temperature 3
Chiller Control Board	J20-6	Comp 4 Motor Temperature 1
Chiller Control Board	J20-7	Comp 4 Motor Temperature 2
Chiller Control Board	J20-8	Comp 4 Motor Temperature

**TABLE 21 - ANALOG INPUT CONNECTIONS (CONT'D)**

BOARD	HEADER	ANALOG INPUT
Chiller Control Board	J23-13	Sys 3 Suction Temperature
Chiller Control Board	J23-3	Sys 3 Oil Temperature
Chiller Control Board	J23-16	Sys 3 Discharge Temperature
Chiller Control Board	J23-6	Sys 3 Flash Tank Level Sensor
Chiller Control Board	J23-20	Sys 3 Suction Pressure
Chiller Control Board	J23-22	Sys 3 Oil Temperature
Chiller Control Board	J23-24	Sys 3 Discharge Pressure
Chiller Control Board	J24-13	Sys 4 Suction Temperature
Chiller Control Board	J24-3	Sys 4 Oil Temperature
Chiller Control Board	J24-16	Sys 4 Discharge Temperature
Chiller Control Board	J24-6	Sys 4 Flash Tank Level Sensor
Chiller Control Board	J24-20	Sys 4 Suction Pressure
Chiller Control Board	J24-22	Sys 4 Oil Pressure
Chiller Control Board	J24-24	Sys 4 Discharge Pressure
VSD Logic Board	J1-1 to J1-2	Comp 1 Phase A Motor Current
VSD Logic Board	J1-3 to J3-4	Comp 1 Phase B Motor Current
VSD Logic Board	J1-5 to J1-6	Comp 1 Phase C Motor Current
VSD Logic Board	J1-13 to J1-14	Comp 3 Phase A Motor Current
VSD Logic Board	J1-15 to J1-16	Comp 3 Phase B Motor Current
VSD Logic Board	J1-17 to J1-18	Comp 3 Phase C Motor Current
VSD Logic Board	J2-1 to J2-2	Comp 2 Phase A Motor Current
VSD Logic Board	J2-3 to J2-4	Comp 2 Phase B Motor Current
VSD Logic Board	J2-5 to J2-6	Comp 2 Phase C Motor Current
VSD Logic Board	J2-9 to J2-10	Comp 4 Phase A Motor Current
VSD Logic Board	J2-11 to J2-12	Comp 4 Phase B Motor Current
VSD Logic Board	J2-13 to J2-14	Comp 4 Phase C Motor Current
VSD Logic Board	J3-1	+DC Bus Voltage 1
VSD Logic Board	J3-2	1/2 DC Bus Voltage 1
VSD Logic Board	J3-3	-DC Bus Voltage 1
VSD Logic Board	J3-4	-DC Bus Voltage 2
VSD Logic Board	J3-5	1/2 DC Bus Voltage 2
VSD Logic Board	J3-6	+DC Bus Voltage 2
VSD Logic Board	J6-8	Comp 1 IGBT Baseplate Temperature
VSD Logic Board	J7-8	Comp 3 IGBT Baseplate Temperature
VSD Logic Board	J8-8	Comp 2 IGBT Baseplate temperature
VSD Logic Board	J9-8	Comp 4 IGBT Baseplate Temperature
VSD Logic Board	R19	Comp 1 Overload Adjust
VSD Logic Board	R42	Comp 3 Overload Adjust
VSD Logic Board	R64	Comp 2 Overload Adjust
VSD Logic Board	R86	Comp 4 Overload Adjust

## DIGITAL INPUT CONNECTIONS

TABLE 22 lists the digital inputs and the circuit board they are located on. The Digital input signals are typically referenced to the common (return, ground) in the system.

J12-3 can also be used as common, as well as chassis ground, or the common terminal point on the Chiller Control Board. *See the wiring diagrams.*

**TABLE 22 - DIGITAL INPUT CONNECTIONS**

BOARD	HEADER	ANALOG OUTPUT
Chiller Control Board	J4-2	Unit Switch 1
Chiller Control Board	J4-3	Unit Switch 2
Chiller Control Board	J4-4	Sys 1 HPCO
Chiller Control Board	J4-5	Sys 2 HPCO
Chiller Control Board	J4-6	VSD Fault Relay 1
Chiller Control Board	J5-1	Sys 3 HPCO
Chiller Control Board	J5-2	Sys 4 HPCO
Chiller Control Board	J5-3	VSD Fault Relay (Unused)
Chiller Control Board	J6-2	Flow Switch
Chiller Control Board	J6-3	Print
Chiller Control Board	J6-4	Sys 1/3 Run Permissive
Chiller Control Board	J6-5	Sys 2/4 Run Permissive
Chiller Control Board	J6-6	Spare
Chiller Control Board	J7-1 to J7-2	Config0
Chiller Control Board	J7-3 to J7-4	Config1
Chiller Control Board	J7-5 to J7-6	Config2
Chiller Control Board	J7-7 to J7-8	Config3
Chiller Control Board	J7-9 to J7-10	Spare 0
Chiller Control Board	J7-11 to J7-12	Spare 1
VSD Logic Board	J1-10	2 Compressor Select
VSD Logic Board	J1-11	3 Compressor Select
VSD Logic Board	J1-12	4 Compressor Select
VSD Logic Board	J5-1 to J5-2	
VSD Logic Board	J5-3 to J5-4	
VSD Logic Board	J6-2	Comp 1 Phase A Gate Driver Fault
VSD Logic Board	J6-5	Comp 1 Phase C Gate Driver Fault
VSD Logic Board	J6-12	Comp 1 Phase B Gate Driver Fault
VSD Logic Board	J7-2	Comp 3 Phase A Gate Driver Fault
VSD Logic Board	J7-5	Comp 3 Phase C Gate Driver Fault
VSD Logic Board	J7-12	Comp 3 Phase B Gate Driver Fault
VSD Logic Board	J7-2	Comp 2 Phase A Gate Driver Fault
VSD Logic Board	J7-5	Comp 2 Phase C Gate Driver Fault
VSD Logic Board	J7-12	Comp 2 Phase B Gate Driver Fault
VSD Logic Board	J8-2	Comp 4 Phase A Gate Driver Fault
VSD Logic Board	J8-5	Comp 4 Phase C Gate Driver Fault
VSD Logic Board	J8-12	Comp 4 Phase B Gate Driver Fault

**TABLE 22 - DIGITAL INPUT CONNECTIONS (CONT'D)**

BOARD	HEADER	ANALOG OUTPUT
VSD Logic Board	J11-2	Phase Loss Fault 1
VSD Logic Board	J11-6	Phase Loss Fault 2
VSD Logic Board	SW1	Test Pushbutton
VSD Logic Board	J10-5 to J10-6	Comp 1/3 Run (from control panel)
VSD Logic Board	J10-7 to J10-8	Comp 2/4 (from control panel)

**ANALOG OUTPUT CONNECTIONS**

TABLE 23 lists the analog outputs and the circuit board they are located on. The analog output signals are feed to the associated control device from the 2 wires in the associated plug.

**TABLE 23 - ANALOG OUTPUT CONNECTIONS**

BOARD	HEADER	ANALOG OUTPUT
Chiller Control Board	J15-1 to J15-2	Sys 1 Flash Tank Feed Valve
Chiller Control Board	J15-3 to J15-4	Sys 1 Flash tank Drain Valve
Chiller Control Board	J15-5 to J15-6	Sys 2 flash Tank Feed Valve
Chiller Control Board	J15-7 to J15-8	Sys 2 Flash Tank Drain Valve
Chiller Control Board	J14-1 to J14-6	Sys 3 Flash Tank Feed Valve
Chiller Control Board	J14-2 to J14-7	Sys 3 Flash Tank Drain Valve
Chiller Control Board	J14-3 to J14-8	Sys 4 Flash Tank Feed Valve
Chiller Control Board	J14-4 to J14-9	Sys 4 Flash Tank Feed Valve
Chiller Control Board	J25-1 to J25-5	Sys 1 Condenser Fan Speed (Future)
Chiller Control Board	J25-2 to J25-6	Sys 2 Condenser Fan Speed (Future)
Chiller Control Board	J25-3 to J25-7	Sys 3 Condenser Fan Speed (Future)
Chiller Control Board	J25-4 to J25-8	Sys 4 Condenser Fan Speed (Future)

## DIGITAL OUTPUT CONNECTIONS

TABLE 24 lists the digital outputs and the plug/terminals of the circuit board they originate from. Not all of the outputs will be used on every unit. Signal levels may be 12VDC, 120VAC, or a dry contact (no voltage) closure). 120VAC signals typically may show only one connection point; the other will be neutral (Wire 2). Outputs which reference multiple boards, such as “Chiller Control Board / Relay Board 1” indicate the signal originates on the Chiller Control Board as a 0 to 12VDC digital signal (example: J9-1) that is then fed to the Relay board and output as a dry contact closure

between TB1-20 and 19. In this case, outputs from both boards are called out in the table.

The 0 to 120VAC single digital outputs from the Relay Output Boards are referenced to neutral (Wire 2). For example, the fan output on TB1-6 is a single 120VAC output. The 0 to 12VDC outputs from the Chiller Control Board are referenced to common (return, ground) in the system. J12-3 can also be used as common, as well as chassis ground, or the common terminal point on the Chiller Control Board. *See the wiring diagrams. Refer to the wiring diagrams whenever there is a requirement for tracing out these signals.*

**TABLE 24 - DIGITAL OUTPUT CONNECTIONS**

BOARD	HEADER	ANALOG OUTPUT
Chiller Control / Relay Board 1	J9-1 / TB1-20 and 19	Evaporator Heater
Chiller Control / Relay Board 1	J9-2 / TB1-18 and 17	Sys 1/3 VSD Run
Chiller Control / Relay Board 1	J9-3 / TB1-16 and 15	Sys 1/3 Alarm
Chiller Control / Relay Board 1	J9-4 / TB1-14 and 13	Evaporator Heater 2
Chiller Control / Relay Board 1	J9-5 / TB1-12 and 11	Sys 1 SPARE
Chiller Control / Relay Board 1	J9-6 / TB1-10 and 9	SPARE
Chiller Control / Relay Board 1	J9-7 / TB1-8 and 7	SPARE
Chiller Control / Relay Board 1	J9-8 / TB1-6	Sys 1 Condenser Fans Output 1
Chiller Control / Relay Board 1	J9-9 / TB1-5	Sys 1 Condenser Fans Output 2
Chiller Control / Relay Board 1	J9-10 / TB1-4	Sys 1 Condenser Fans Output 3
Chiller Control / Relay Board 1	J9-11 / TB1-3	Sys 1 Compressor Heater
Chiller Control / Relay Board 1	J9-12 / TB1-2	Sys 1 Economizer Solenoid Valve
Chiller Control / Relay Board 2	J10-1 / TB1- 20 and 19	Evaporator Pump Start
Chiller Control / Relay Board 2	J10-2 / TB1-18 and 17	Sys 2/4 VSD Run
Chiller Control / Relay Board 2	J10-3 / TB1-18 and 15	Sys 2/4 Alarm
Chiller Control / Relay Board 2	J10-4 / TB1-16 and 14	Chiller Run
Chiller Control / Relay Board 2	J10-5 / TB1-12 and 11	Sys 2 SPARE
Chiller Control / Relay Board 2	J10-6 / TB1-10 and 9	SPARE
Chiller Control / Relay Board 2	J10-7 / TB1-8 and 7	SPARE
Chiller Control / Relay Board 2	J10-8 / TB1-6	Sys 2 Condenser Fans Output 1
Chiller Control / Relay Board 2	J10-9 / TB1-5	Sys 2 Condenser Fans Output 2
Chiller Control / Relay Board 2	J10-10 / TB1-4	Sys 2 Condenser Fans Output 3
Chiller Control / Relay Board 2	J10-11 / TB1-3	Sys 2 Compressor Heater
Chiller Control / Relay Board 3	J10-12 / TB1-2	Sys 2 Economizer Solenoid Valve
Chiller Control / Relay Board 3	J11-1 / TB1-20 and 19	Sys 4 Condenser Fan Output 1
Chiller Control / Relay Board 3	J11-2 / TB1-18 and 17	Sys 4 Condenser Fan Output 2
Chiller Control / Relay Board 3	J11-3 / TB1-16 and 15	Sys 4 Condenser Fan Output 3
Chiller Control / Relay Board 3	J11-4 / TB1-14 and 13	Sys 4 Compressor Heater
Chiller Control / Relay Board 3	J11-5 / TB1-12 and 11	Sys 4 Economizer Solenoid Valve
Chiller Control / Relay Board 3	J11-6 / TB1-10 and 9	Sys 4 SPARE

**TABLE 24 - DIGITAL OUTPUT CONNECTIONS (CONT'D)**

BOARD	HEADER	ANALOG OUTPUT
Chiller Control / Relay Board 3	J11-7 / TB1-8 and 7	Sys 3 SPARE
Chiller Control / Relay Board 3	J11-8 / TB1-6	Sys 3 Condenser Fans Output 1
Chiller Control / Relay Board 3	J11-9 / TB1-5	Sys 3 Condenser Fans Output 2
Chiller Control / Relay Board 3	J11-10 / TB1-4	Sys 3 Condenser Fans Output 3
Chiller Control / Relay Board 3	J11-11 / TB1-3	Sys 3 Compressor Heater
Chiller Control / Relay Board 3	J11-12 / TB1-2	Sys 3 Economizer Solenoid Valve
VSD Logic Board	J6-1	Comp 1 Phase A+ IGBT Gating Signal
VSD Logic Board	J6-3	Comp 1 Phase B- IGBT Gating Signal
VSD Logic Board	J6-4	Comp 1 Phase C+ IGBT Gating Signal
VSD Logic Board	J6-10	Comp 1 Phase A- IGBT Gating Signal
VSD Logic Board	J6-11	Comp 1 Phase B+ IGBT Gating Signal
VSD Logic Board	J6-13	Comp 1 Phase C- IGBT Gating Signal
VSD Logic Board	J6-14	Comp1 Enable
VSD Logic Board	J7-1	Comp 3 Phase A+ IGBT Gating Signal
VSD Logic Board	J7-3	Comp 3 Phase B- IGBT Gating Signal
VSD Logic Board	J7-4	Comp 3 Phase C+ IGBT Gating Signal
VSD Logic Board	J7-10	Comp 3 Phase A- IGBT Gating Signal
VSD Logic Board	J7-11	Comp 3 Phase B+ IGBT Gating Signal
VSD Logic Board	J7-13	Comp 3 Phase C- IGBT Gating Signal
VSD Logic Board	J7-14	Comp 3 Enable
VSD Logic Board	J8-1	Comp 2 Phase A+ IGBT Gating Signal
VSD Logic Board	J8-3	Comp 2 Phase B- IGBT Gating Signal
VSD Logic Board	J8-4	Comp 2 Phase C+ IGBT Gating Signal
VSD Logic Board	J8-10	Comp 2 Phase A- IGBT Gating Signal
VSD Logic Board	J8-11	Comp 2 Phase B+ IGBT Gating Signal
VSD Logic Board	J8-13	Comp 2 Phase C- IGBT Gating Signal
VSD Logic Board	J8-14	Comp 2 Enable
VSD Logic Board	J9-1	Comp 4 Phase A+ IGBT Gating Signal
VSD Logic Board	J9-3	Comp 4 Phase B- IGBT Gating Signal
VSD Logic Board	J9-4	Comp 4 Phase C+ IGBT Gating Signal
VSD Logic Board	J9-10	Comp 4 Phase A- IGBT Gating Signal
VSD Logic Board	J9-11	Comp 4 Phase B+ IGBT Gating Signal
VSD Logic Board	J9-13	Comp 4 Phase C- IGBT Gating Signal
VSD Logic Board	J9-12	Comp 4 Enable
VSD Logic Board	J11-3	Pre-charge Enable 1
VSD Logic Board	J11-7	Pre-charge Enable 2
VSD Logic Board	J10-1 to J10-2	VSD Fan / Pump Run
VSD Logic Board	J10-3 to J10-4	VSD Fault Relay (to control panel)

**BACNET, MODBUS AND YORKTALK 2 COMMUNICATIONS**

Data can be read and in some cases modified using a serial communication BACnet, Modbus or YorkTalk 2 network connection. This information allows communications of chiller operating parameters and external control changes to setpoint, load limiting, and start/stop commands.

BACnet and YorkTalk 2 RS485 networks are wired to the + and - terminals of TB1 for port 1 communications. Modbus network connection has the option of RS232 or RS485 connection for port 2 communications. Modbus network is wired to either TB2 or TB3 as follows:

- RS-485: connect to TB2 - Network (-1) to TB2 (-1); Network (+1) to TB2 (+1)

- RS-232: connect to TB3 - Network (RX) to TB3 (TXD); Network (TX) to TB3 (RXD); Network (GND) to TB3 (GND)

*Refer to FIG. 59 “Control Board Connections” for TB1, and TB2 locations.*

In most cases, communication parameters will need to be modified. TABLE 26 “Values Required for BAS Communication” lists setup parameters for the available protocols. Modification is accomplished by pressing the PROGRAM, DOWN ARROW, DOWN ARROW, DOWN ARROW, DOWN ARROW, and ENTER keys in sequence. The list below shows the displays for the values that may be modified:

DE MODIFIER ADDRESS  
XXXXX

DE MODIFIER OFFSET  
XX

P1 PROTOCOL  
XXXXXX

P1 MANUAL MAC ADDRESS  
XXX

P1 BAUD RATE  
XXXXX

P1 PARITY  
XXXXX

P1 STOP BITS  
X

P2 PROTOCOL  
XXXXXXXXXX

P2 MANUAL MAC ADDRESS  
XXX

P2 BAUD RATE  
XXXXX

P2 PARITY  
XXXXX

P2 STOP BITS  
X

P2 HW SELECT BIT  
XXXXX

REAL TIME ERROR ##  
RESET 1 = YES, 0 = NO 0

Note: See TABLE 27 for error descriptions

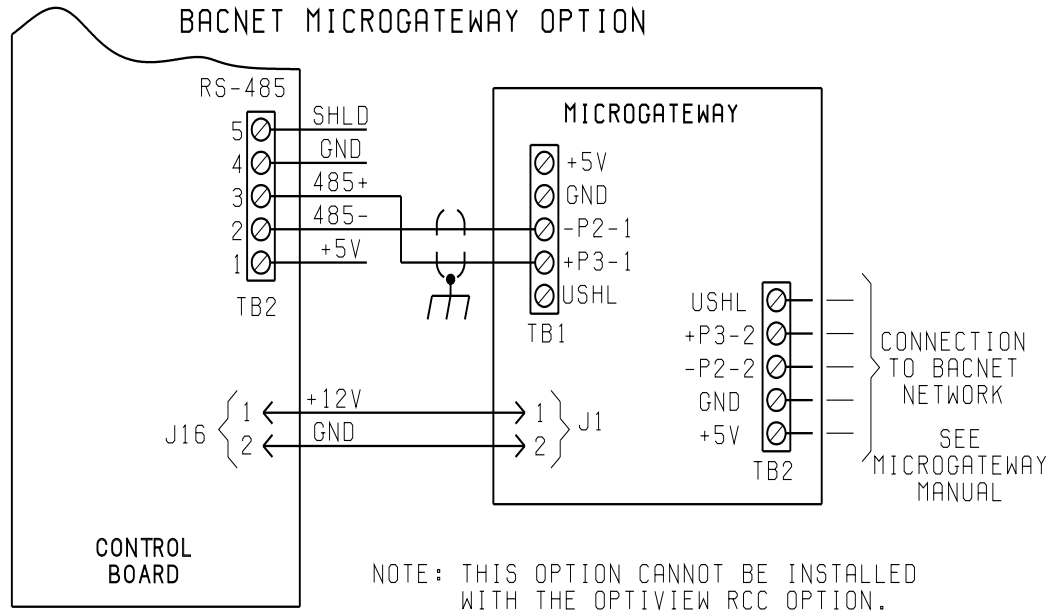

**FIG. 59 - CONTROL BOARD CONNECTIONS**

LD10637

The Chiller Control Board contains a dual UART for RS-485 and RS-232 communications. UART1 is dedicated to RCC and ISN communications over an RS-485 link. UART2 is dedicated to internal communications within the chiller. The RS-485 port is configured

for 4800 baud, 1 start bit, 8 data bits, odd parity, and 1 stop bit. Connections for ISN communications are on the Chiller Control Board on TB1/TB2. TB2 on the Microgateway is utilized for ISN comms connection. P3 is RS485+, P2 is RS485-, and USHL is the shield.

The table below shows the minimum, maximum, and default values.

**TABLE 25 – MINIMUM, MAXIMUM AND DEFAULT VALUES**

DESCRIPTION	MINIMUM	MAXIMUM	DEFAULT
DE MODIFIER ADDRESS	-1	41943	-1
DE MODIFIER OFFSET	-1	99	-1
P1 BAUD RATE	1200	76800	4800
	1200, 4800, 9600, 19200, 38400, 76800, AUTO SELECTABLE		
P2 BAUD RATE	1200	57600	1200
	1200, 4800, 9600, 19200, 38400, 57600 SELECTABLE		
P1, P2 MANUAL MAC ADDRESS	-1	127	-1
P1, P2 PARITY	NONE	IGNORE	NONE
	NONE, EVEN, ODD, IGNORE SELECTABLE		
P1 PROTOCOL	BACNET	API	BACNET
	BACNET, API SELECTABLE		
P2 PROTOCOL	TERMINAL	MODBUS CLIENT	API
	TERMINAL, MODBUS IO, MODBUS SERVER, API, MODBUS CLIENT SELECTABLE		
P1, P2 STOP BITS	1	2	1
RESET REAL TIME ERROR	NO	YES	NO

The table below shows set-up requirements for each communication protocol.

**TABLE 26 – VALUES REQUIRED FOR BAS COMMUNICATION**

SETTING DESCRIPTION	PROTOCOL		
	BACNET MS/TP	MODBUS RTU <sup>5</sup>	YORKTALK 2
DE MODIFIER ADDRESS	0 TO 41943 <sup>(3)</sup>	1	-1
DE MODIFIER OFFSET	0 TO 99 <sup>(4)</sup>	0	N/A
P1 PROTOCOL	BACNET	N/A	N/A
P1 MANUAL MAC ADDRESS	0-127 <sup>(1)</sup>	N/A	N/A
P1 BAUD RATE	9600 To 76800 or Auto Selectable <sup>(1)</sup>	N/A	N/A
P1 PARITY	NONE	N/A	N/A
P1 STOP BITS	1	N/A	N/A
P2 PROTOCOL	N/A	MODBUS SVR	N/A
P2 MANUAL MAC ADDRESS	N/A	0-127 <sup>(1)</sup>	N/A
P2 BAUD RATE	N/A	19,200 <sup>(2)</sup>	N/A
P2 PARITY	N/A	NONE <sup>(2)</sup>	N/A
P2 STOP BITS	N/A	1	N/A
P2 HW SELECT BIT	N/A	RS-485 OR RS-232 <sup>(1)</sup>	N/A
RESET REAL TIME ERROR	N/A	N/A	N/A
P1 HW SELECT BIT	N/A	N/A	N/A
CHILLER ID	N/A	N/A	0

<sup>1</sup>as Required By Network

<sup>2</sup>or Other As Required By Network

<sup>3</sup>number Is Multiplied By 100, Set As Required By Network

<sup>4</sup>number Is Added To De Modifier Address, Set As Required By Network

<sup>5</sup>unit Operating Software Version C.Mmc.13.03 Or Later Required For Modbus Protocol

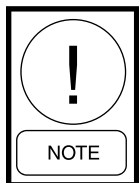

***Reboot required (cycle power) after settings are changed.***

The table below shows the real time error numbers that may be encountered during communication setup and a description of each.

**TABLE 27 – REAL TIME ERROR NUMBERS**

ERROR NUMBER (##)	DESCRIPTION
0	ALL OK
1	DATUM TYPE OK TEST FAILED
2	ENGLISH TEXT TOO LONG
3	FLOATING POINT EXCEPTION
4	GET PACKET FAILED
5	GET TYPE FAILED
6	INVALID UNIT CONVERSION
7	INVALID HARDWARE SELECTION
8	REAL TIME FAULT
9	SPANISH TEXT TOO LONG
10	THREAD EXITED
11	THREAD FAILED
12	THREAD STALLED
13	IO BOARD RESET
14	BRAM INVALID
15	BACNET SETUP FAILED

## BACnet and Modbus Communications

Chiller data that can be read and modified using specific BACnet or Modbus Register Addresses; and the data associated with the addresses, is outlined in the following description:

### ANALOG WRITE POINTS

This data can be read and modified using a BACnet or Modbus network connection. The Modbus Register Address for these points is 1025 plus AV #.

### BINARY WRITE POINTS

This data can be read and modified using a BACnet or Modbus network connection. The Modbus Register Address for these points is 1537 plus BV #.

### ANALOG READ ONLY POINTS

This data can be read using a BACnet or Modbus network connection and can NOT be modified using this connection. The Modbus Register Address for these points is 513 plus AI #.

### BINARY MONITOR ONLY POINTS

This data can be read using a BACnet or Modbus network connection and can NOT be modified using this connection. The Modbus Register Address for these points is 1281 plus BI #.

*Refer to TABLE 28 for complete list of BACnet and Modbus registers.*

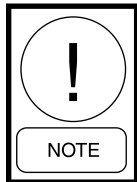

***The latest data map information is listed on the Johnson Controls Equipment Integration website.***

## Communications Data Map Notes

(See TABLE 28)

1. IPU II based units are configured for Native BACnet MS/TP and Modbus RTU communications. Microgateway or E-Link not required for these two communication protocols.
2. BACnet Object Types: 0= Analog In, 1 = Analog Out, 2= Analog Value, 3= Binary In, 4 = Binary Output, 5= Binary Value, 8= Device, 15 = Alarm Notification (0 through 127 are reserved ASHRAE Objects).
3. WC= Inches of water column; CFM = Cubic Feet per Minute; FPM = Feet per Minute; PSI = Lbs per square inch; Pa = Pascals; kPa = Kilopascals; PPM = Part per Million; kJ/kg = Kilojoules per Kilogram.
4. Water Cooled Scroll units use the same firmware as Air-Cooled Scroll units, ignoring Fan Control.

TABLE 28 - BACNET AND MODBUS COMMUNICATIONS DATA MAP

2/25/2009

Board: 031-02630-xxx w/ 031-02550

Native Modbus and BACnet MS/TP Data Maps

YCAL/YCUL/YCWL/YLAA IPU II

ITEM	Version	Date	York PN	Check Sum	Comments
1	C.MMC.13.00	29-Nov-06	031-02755-001		Standard with Board: 031-02630-xxx w/ 031-02550
2	C.MMC.15.00	29-Nov-06	031-02755-002		Basildon with Board: 031-02630-xxx w/ 031-02550
3	C.MMC.14.00	29-Nov-06	031-02755-003		MMHP with Board: 031-02630-xxx w/ 031-02550
4	C.MMC.16.00	29-Nov-06	031-02755-004		Basildon MMHP with Board: 031-02630-xxx w/ 031-02550
5	C.MMC.13.02	17-Oct-08	031-02755-001		Standard Micro Board 031-02550-xxx. Fix native Modbus communications. Fix Café Metric functionality (SCR-766)
6	C.MMC.14.02	17-Oct-08	031-02755-003		MMHP with Board: 031-02630-xxx w/ 031-02550 Fix native Modbus communications. Fix Café Metric functionality (SCR-766)
7	C.MMC.16.02	17-Oct-08	031-02755-004		Basildon MMHP with Board: 031-02630-xxx w/ 031-02550 Fix native Modbus communications. Fix Café Metric functionality (SCR-766)
8					
9					
10					

ITEM REF NUM	BACnet NAME	BACnet Object/Inst ance	MODBUS ADDRESS	MODBUS Data Type Supported	ENG UNITS	READ WRITE	POINT DESCRIPTION	Point List Code
1					SEE NOTE 5		SEE NOTE 1	S=Standard, O = Optional, N = Not Available
3	<b>ANALOG WRITE POINTS</b>							
4	REM_SETP	AV_1	1026	03.06,16	F°	R/W	Setpoint Cooling Setpoint(HP Only), 99 = Auto; (40°F - 70°F)	
5	SP_REM_SP_S1	AV_2	1027	03.06,16	PSIG	R/W	Sys 1 Setpoint (Suction Pressure Control units only)	
6	LOAD_LIMIT	AV_3	1028	03.06,16	index	R/W	Load Limit Stage (0, 1, 2)	
7	REM_CR	AV_4	1029	03.06,16	F°	R/W	Cooling Range (DAT Mode Only)	
8	SP_REM_SP_S2	AV_5	1030	03.06,16	PSIG	R/W	Sys 2 Setpoint (Suction Pressure Control)	
9	REM_SP_HEAT	AV_6	1031	03.06,16	F°	R/W	Heating Setpoint (HP Only), 999 = Auto (95°F - 122°F)	
10	HP_MODE	AV_7	1032	03.06,16	index	R/W	Mode (HP Only) (0=Panel, 1=Cooling, 2=Heating)	
11								
12	<b>BINARY WRITE POINTS</b>							
13	START_STOP	BV_1	1538	01,03,05,15,06,	0, 1	R/W	Stop Start Command	
14	SS_SYS1	BV_2	1539	01,03,05,15,06,	0, 1	R/W	Sys 1 Start/Stop ( Suction Pressure (SP) Control Only)	
15	SS_SYS2	BV_3	1540	01,03,05,15,06,	0, 1	R/W	Sys 2 Start/Stop ( Suction Pressure (SP) Control Only)	
16	<b>ANALOG READ ONLY POINTS</b>							
17	LOHLT	AI_1	514	03.04	F°	R	Leaving Chilled Liquid Temp	
18	RCHLT	AI_2	515	03.04	F°	R	Return Chilled Liquid Temp	
19	DAT	AI_3	516	03.04	F°	R	Condensing Unit Models Only	
20	S1_SUCT_TEMP	AI_4	517	03.04	F°	R	Electronic Expansion Valve Models Only	
21	OAT	AI_5	518	03.04	F°	R	Ambient Air Temperature	
22	S1_SUCT_SHEAT	AI_6	519	03.04	F°	R	Sys 1 Suction Superheat ( EEV Models Only)	
23	S1_RUN_TIME	AI_7	520	03.04	seconds	R	Sys 1 Run Time (seconds)	
24	S1_SUCT_PR	AI_8	521	03.04	PSIG	R	Sys 1 Suction Pressure	
25	S1_DSCH_PR	AI_9	522	03.04	PSIG	R	Sys 1 Discharge Pressure	
27	S1_CIR_TEMP	AI_10	523	03.04	F°	R	Sys 1 Cooler Inlet Refrigerant Temp (R-407c Models Only)	
28	S1_DEF_TEMP	AI_11	524	03.04	F°	R	Sys 1 Defrost Temperature (HP Only)	
29	S1_EEV_OUT	AI_12	525	03.04	F°	R	System 1 EEV Output % ( EEV Models Only)	
30	S1_AR_TIMER	AI_13	526	03.04	seconds	R	Sys 1 Anti-Recycle Timer	
31	AC_TIMER	AI_14	527	03.04	seconds	R	Anti-Coincident Timer	
32	S2_SUCT_TEMP	AI_15	528	03.04	F°	R	System 2 Suction Temp ( EEV Models Only)	
33	S2_RUN_TIME	AI_16	529	03.04	seconds	R	Sys 2 Run Time (seconds)	
34	S2_SUCT_PR	AI_17	530	03.04	PSIG	R	Sys 2 Suction Pressure	
35	S2_DSCH_PR	AI_18	531	03.04	PSIG	R	Sys 2 Discharge Pressure	
36	S2_CIR_TEMP	AI_19	532	03.04	F°	R	Sys 2 Cooler Inlet Refrigerant Temperature(R-407c Only)	
37	S2_DEF_TEMP	AI_20	533	03.04	F°	R	Sys 2 Defrost Temperature (HP Only)	
38	S2_SUCT_SH	AI_21	534	03.04	F°	R	Sys 2 Suction SuperHeat (EEV Models Only)	
39	S2_AR_TIMER	AI_22	535	03.04	F°	R	Sys 2 Anti-Recycle Timer	
40	S2_EEV_OUT	AI_23	536	03.04	seconds	R	Sys 2 Suction Superheat ( EEV Models Only)	

Property of JCI/York International. Subject to change without notice  
Middle Market IPU II NATIVE BACnet\_Modbus Data Maps\_ Rev\_A\_06.xls

TABLE 28 - BACNET AND MODBUS COMMUNICATIONS DATA MAP (CONT'D)

2/25/2009

ITEM REF NUM	BACnet NAME	BACnet Object/Inst. ance	MODBUS Address	MODBUS Data Type Supported	ENG UNITS	READ WRITE	POINT DESCRIPTION	Point List Code											
								1	2	3	4	5	6	7	8	9	10		
41	NUM_COMPS	AI_24	537	03.04	count	R	Number of Compressors												
42	S1_OP_CODE	AI_25	538	03.04	index	R	Sys 1 Operational Cycle (Table A & B)												
43	S1_FLT_CODE	AI_26	539	03.04	index	R	Sys 1 Fault Cycle (Table A & B)												
44	S2_OP_CODE	AI_27	540	03.04	index	R	Sys 2 Operational Cycle (Table A & B)												
45	S2_FLT_CODE	AI_28	541	03.04	index	R	Sys 2 Fault Cycle (Table A & B)												
46	S1_DBG_CODE	AI_29	542	03.04	index	R	Sys 1 Debug Code												
47	S1_FAN_STAGE	AI_30	543	03.04	count	R	Sys 1 Condenser Fan Stage												
48	S2_DBG_CODE	AI_31	544	03.04	index	R	Sys 2 Debug Code												
49	S2_FAN_STAGE	AI_32	545	03.04	count	R	Sys 2 Condenser Fan Stage												
50	CONTROL_MODE	AI_33	546	03.04	count	R	Unit Control Mode (0=Leaving Water, 1=Return Water, 2=Discharge Air, 3=Suction Press, 4=Cooling, 5=Heating)												
51	AR_TIME	AI_34	547	03.04	seconds	R	Anti-Recycle Time (Programmed)												
52	LCHLT_CUT	AI_35	548	03.04	F°	R	Leaving Chilled Liquid Temp Cutout												
53	LOW_AMB_CUT	AI_36	549	03.04	F°	R	Low Ambient Temperature Cutout												
54	SUCT_P_CO_HT	AI_37	550	03.04	PSIG	R	Low Suction Pressure Cutout Heating (HP Only)												
55	L_SUCT_P_CO	AI_38	551	03.04	PSIG	R	Low Suction Pressure Cutout (Cooling on HP units)												
56	H_DSCH_P_CO	AI_39	552	03.04	PSIG	R	High Discharge Pressure Cutout												
57	COOL_SETP	AI_40	553	03.04	F°	R	Setpoint												
58	SP_SETP_S1	AI_41	554	03.04	F°	R	Setpoint 1 (SP Control)												
59	CONTROL_RG	AI_42	555	03.04	F°	R	Cooling Range												
60	SP_CTL_RG_S1	AI_43	556	03.04	F°	R	Cooling Range 1 (SP Control)												
61	SP_SETP_S2	AI_44	557	03.04	F°	R	Setpoint 2 (SP Control)												
62	HEAT_SETP	AI_45	558	03.04	F°	R	Heating Setpoint (HP Only)												
63	SP_CTL_RG_S2	AI_46	559	03.04	F°	R	Cooling Range 2 (SP Control)												
64	HEAT_RANGE	AI_47	560	03.04	F°	R	Heating Range (HP Only)												
65	S1_DSCH_TEMP	AI_48	561	03.04	F°	R	Sys 1 Discharge Temperature (EEV Only)												
66	S1_DSCH_SHEAT	AI_49	562	03.04	F°	R	Sys 1 Discharge Superheat (EEV Only)												
67	S2_DSCH_TEMP	AI_50	563	03.04	F°	R	Sys 2 Discharge Temperature (EEV Only)												
68	S2_DSCH_SH	AI_51	564	03.04	F°	R	Sys 2 Discharge Superheat (EEV Only)												
69	LEAVING_HOT	AI_52	565	03.04	F°	R	Leaving Liquid Hot Temp (R-410a)												
70	RETURN_HOT	AI_53	566	03.04	F°	R	Return Liquid Hot Temp (R-410a)												
71																			
72																			
74	<b>BINARY MONITOR ONLY POINTS</b>																		
75	S1_ALARM	BI_1	1282	01.02.03	0.1	R	Sys 1 Alarm												
76	S2_ALARM	BI_2	1283	01.02.03	0.1	R	Sys 2 Alarm												
77	EVAP_HTR	BI_3	1284	01.02.03	0.1	R	Evaporator Heater Status												
78	EVAP_PUMP	BI_4	1285	01.02.03	0.1	R	Evaporator Pump Status												
79	S1_C1_RUN	BI_5	1286	01.02.03	0.1	R	Sys 1 Comp 1 Run												
80	S2_C1_RUN	BI_6	1287	01.02.03	0.1	R	Sys 2 Comp 1 Run												
81	S1_LLSV	BI_7	1288	01.02.03	0.1	R	Sys 1 Liquid Line Solenoid Valve												
82	S1_MODE_SV	BI_8	1289	01.02.03	0.1	R	Sys 1 Mode Solenoid Valve (HP Only)												
83	S1_HGBV	BI_9	1290	01.02.03	0.1	R	Sys 1 Hot Gas Bypass Valve												
84	S1_BHS	BI_10	1291	01.02.03	0.1	R	Bivalent Heat Source (HP Only)												
85	S1_C2_RUN	BI_11	1292	01.02.03	0.1	R	Sys 1 Comp 2 Run												
86	S2_C2_RUN	BI_12	1293	01.02.03	0.1	R	Sys 2 Comp 2 Run												
87	S2_LLSV	BI_13	1294	01.02.03	0.1	R	Sys 2 Liquid Line Solenoid Valve												
88	S2_MODE_SV	BI_14	1295	01.02.03	0.1	R	Sys 2 Mode Solenoid Valve (HP Only)												
89	LEAD_SYS	BI_15	1296	01.02.03	0.1	R	Lead System (0 = Sys 1, 1 = Sys 2)												
90	S1_C3_RUN	BI_16	1297	01.02.03	0.1	R	Sys 1 Comp 3 Run												
91	S2_C3_RUN	BI_17	1298	01.02.03	0.1	R	Sys 2 Comp 3 Run												
92	CH_LIQ_TYPE	BI_18	1299	01.02.03	0.1	R	Chilled Liquid Type (0=Water, 1=Glycol)												
93	AMB_MODE	BI_19	1300	01.02.03	0.1	R	Ambient Control Mode (0=Std Amb, 1=Low Amb)												

TABLE 28 - BACNET AND MODBUS COMMUNICATIONS DATA MAP (CONT'D)

2/25/2009

ITEM REF NUM	BACnet NAME	BACnet Object/Instance	MODBUS ADDRESS	MODBUS Data Type Supported	ENG UNITS	READ WRITE	POINT DESCRIPTION	Point List Code												
								1	2	3	4	5	6	7	8	9	10			
94	CNTL_MODE	BI_20	1301	01.02.03	0, 1	R	Local/Remote Control Mode (0=Local, 1=Remote)													
95	DATA_UNIT	BI_21	1302	01.02.03	0, 1	R	Units (0=Imperial, 1=S)													
96	AUTO_LL	BI_22	1303	01.02.03	0, 1	R	Lead/Lag Control Mode (0=Manual, 1=Auto)													

TABLE A

Code	Operational Codes
0	No Abnormal Condition
1	Unit Switch Off
2	System Switch Off
3	Lock-Out
4	Unit Fault
5	System Fault
6	Remote Shutdown
7	Daily Schedule Shutdown
8	No Run Permissive
9	No Cool Load
10	Anti-Coincidence Timer Active
11	Anti-Recycle Timer Active
12	Manual Override
13	Suction Limiting
14	Discharge Limiting
15	Load Limiting
16	Compressor(s) Running
17	
18	
19	
20	
21	
22	
23	
24	
25	
26	
27	
28	
29	
30	

TABLE B

Code	Fault Codes
0	No Fault
1	VAC Under Voltage
2	Low Ambient Temperature
3	High Ambient Temperature
4	Low Leaving Chilled Liquid Temp
5	High Discharge Pressure
6	High Differential Oil Pressure
7	Low Suction Pressure
8	High Motor Current
9	LLSV Not On
10	Low Battery Warning
11	High Oil Temperature
12	High Discharge Temperature
13	Improper Phase Rotation
14	Low Motor Current / MP / HPCO
15	Motor Current Unbalanced
16	Low Differential Oil Pressure
17	Ground Fault
18	MP/HPCO Fault
19	Low Evaporator Temperature
20	Incorrect Refrigerant Programmed
21	Power Failure, Manual Reset Required
22	Unit Motor Current
23	Low Superheat
24	Sensor Fault
25	
26	MP/HPCO Inhibit
27	
28	
29	
30	

NOTES

1	The IPU II based YCAL /YCUL Units are configured for Native BACnet/MS/TP and Modbus RTU communications. The Microgateway product is not required for these 2 interfaces
2	
3	BACnet Object Types: 0= Analog Out, 2= Analog In, 1 = Analog In, 3= Binary In, 4 = Binary Output, 5= Binary Value, 8= Device, 15 = Alarm Notification (0-127 are reserved ASHRAE Objects)
4	WC= Inches of water column; CFM = Cubic Feet per Minute; FPM = Feet per Minute; PSI = Lbs per square inch; Pa = Pascals; kPa = Kilopascals; PPM = Part Per Million; KJ/kg = Kilojoules per Kilogram
5	See the applicable Middle Market Chiller Operations Manual for more details
6	The YCWL uses the same firmware as a YCAL, it just ignores Fan Control
7	
8	
9	
10	

Property of JCI/York International. Subject to change without notice  
Middle Market IPU II NATIVE BACnet\_Modbus Data Maps\_Rev A\_06.xls

## Yorktalk 2 Communications

### **Received Data (Control Data)**

The unit receives eight data values from the MicroGateway or E-Link. The first four are analog values and the last four are digital values. These eight data values are used as control parameters when in REMOTE mode. When the unit is in LOCAL mode, these eight values are ignored. If the unit receives no valid YorkTalk 2 transmission for 5 minutes it will revert back to all local control values. *TABLE 29 “Yorktalk 2 Communications Data Map” lists the control parameters.* These values are found under feature 54 in the MicroGateway or E-Link.

### **Transmitted Data**

After receiving a valid transmission from the MicroGateway or E-Link, the unit will transmit either operational data or history buffer data depending on the “History Buffer Request” on ENG PAGE 10. Data must be transmitted for every page under feature 54. If there is no value to be sent to a particular page, a zero will be sent. *TABLE 29 “Yorktalk 2 Communications Data Map” shows the data values and page listings for this unit.*

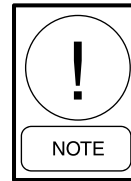

***The latest point map information is listed on the Johnson Controls Equipment Integration website.***

TABLE 29 - YORKTALK 2 COMMUNICATIONS DATA MAP

YCAL/YCWL/YLAA Middle Market w/ 2050, 2550

York Talk 2 MicroGateway / ELINK

Micro Board: 031-02050/02550

Item	Ref.	Version	Date	YORK P N	Checksum	Baud	COMMENTS											
1		C.MMC.03.02		031-02049-001	944D	4800	YCAL Micro Board 031-02050-xxx											
2		C.MMC.03.01		031-02049-001	964B	4800	YCAL Micro Board 031-02050-xxx											
3		C.MMC.03.00		031-02049-001	2226	4800	YCAL Micro Board 031-02050-xxx											
4		C.MMC.13.xx		flash	xxxx	4800	YCAL Micro Board 031-02550-xxx, IPU 2 board.											
5		C.MMC.13.xx		flash	xxxx	4800	YCWL ( water cooled version) Micro Board 031-02550-xxx, IPU 2 board.											
6		C.MMC.13.02		flash	xxxx	4800	Micro Board 031-02550-xxx. Fix native Modbus communications (SCR . Fix Café Metric functionality (SCR-766)											
7																		
8																		
9																		
10																		
<p>Use ASCII page column for interfaces utilizing an ASCII XL Transistor or MicroGateway to communicate to a chiller LINC</p>																		
ENG PAGE REF	ASCII PAGE REF	GPIC Object Type	York Talk Point Type	ISN LINC Descriptive Text	York Talk Character Position	N2 Address	POINT LIST DESCRIPTION	1	2	3	4	5	6	7	8	9	10	ENG PAGE REF
P03	P01		A. Control			ADF 1	Setpoint	S	S	S	S	S	S					P03
P04	P02		A. Control			ADF 2	Load Limit Stage (0, 1, 2)	S	S	S	S	S	S					P04
P05	P03		A. Control			ADF 3	Heating Setpoint (HP and YCWL HP)	S	S	S	S	S	S					P05
P06	P04		A. Control			ADF 4	Mode (HP and YCWL HP only) (0=Panel, 1= Cooling, 2 = Heating)	S	S	S	S	S	S					P06
P07	P05		D. Control			BD 1	Start/Stop Command	S	S	S	S	S	S					P07
P08	P06		D. Control			BD 2												P08
P09	P07		D. Control			BD 3												P09
P10	P08		D. Control			BD 4	History Buffer Request	S	S	S	S	S	S					P10
P11	P09		A. Monitor		8 - 11	ADF 5	Leaving Chilled Liquid Temp	S	S	S	S	S	S					P11
P12	P10		A. Monitor		12 - 15	ADF 6	Return Chilled Liquid Temp	S	S	S	S	S	S					P12
P13	P11		A. Monitor		16 - 19	ADF 7	Leaving Hot Liquid Temp (R-410a) Heat Mode Only	S	S	S	S	S	S					P13
P14	P12		A. Monitor		20 - 23	ADF 8	Discharge Air Temp ( Cond Unit) Return Hot Liquid Temp (410a- Heat Mod	S	S	S	S	S	S					P14
P15	P13		A. Monitor		24 - 27	ADF 9	Leaving Liquid Temp Hot (R-410a)	S	S	S	S	S	S					P15
P16	P14		A. Monitor		28 - 31	ADF 10	Ambient Air Temperature	S	S	S	S	S	S					P16
P17	P15		A. Monitor		32 - 35	ADF 11	Sys 1 Suction Superheat ( EEV only)	S	S	S	S	S	S					P17
P18	P16		A. Monitor		36 - 39	ADF 12	Sys 1 Run Time (seconds)	S	S	S	S	S	S					P18
P19	P17		A. Monitor		40 - 43	ADF 13	Sys 1 Suction Pressure	S	S	S	S	S	S					P19
P20	P18		A. Monitor		44 - 47	ADF 14	Sys 1 Discharge Pressure	S	S	S	S	S	S					P20
P21	P19		A. Monitor		48 - 51	ADF 15	Sys 1 Cooler Inlet Refrigerant Temperature(R-407c Only)	S	S	S	S	S	S					P21
P22	P20		A. Monitor		52 - 55	ADF 16												P22
P23	P21		A. Monitor		56 - 59	ADF 17	Sys 1 EEV Output % (EEV only)	S	S	S	S	S	S					P23
P24	P22		A. Monitor		60 - 63	ADF 18	Sys 1 Anti-Recycle Timer	S	S	S	S	S	S					P24
P25	P23		A. Monitor		64 - 67	ADF 19	Anti-Coincident Timer	S	S	S	S	S	S					P25
P26	P24		A. Monitor		68 - 71	ADF 20	Sys Suction Temp ( EEV only)	S	S	S	S	S	S					P26
P27	P25		A. Monitor		72 - 75	ADF 21	Sys 2 Run Time (seconds)	S	S	S	S	S	S					P27
P28	P26		A. Monitor		76 - 79	ADF 22	Sys 2 Suction Pressure	S	S	S	S	S	S					P28
P29	P27		A. Monitor		80 - 83	ADF 23	Sys 2 Discharge Pressure	S	S	S	S	S	S					P29
P30	P28		A. Monitor		84 - 87	ADF 24	Sys 2 Cooler Inlet Refrigerant Temperature (R-407c systems Only)	S	S	S	S	S	S					P30
P31	P29		A. Monitor		88 - 91	ADF 25	Sys 2 Defrost Temperature (HP only)	S	S	S	S	S	S					P31
P32	P30		A. Monitor		92 - 95	ADF 26	Sys 2 Suction Superheat (EEV only)	S	S	S	S	S	S					P32
P33	P31		A. Monitor		96 - 99	ADF 27	Sys 2 Anti-Recycle Timer	S	S	S	S	S	S					P33
P34	P32		A. Monitor		100 - 103	ADF 28	Sys 2 EEV Output % (EEV only)	S	S	S	S	S	S					P34
P35	P33		A. Monitor		104 - 107	ADF 29	Number of Compressors	S	S	S	S	S	S					P35
P36	P34		D. Monitor		108	BD 5	Sys 1 Alarm	S	S	S	S	S	S					P36
P37	P35		D. Monitor		109	BD 6	Sys 2 Alarm	S	S	S	S	S	S					P37
P38	P36		D. Monitor		110	BD 7	Evaporator Heater Status	S	S	S	S	S	S					P38
P39	P37		D. Monitor		111	BD 8	Evaporator Pump Status	S	S	S	S	S	S					P39
P40	P38		D. Monitor		112	BD 9	Sys 1 Compressor 1 Run	S	S	S	S	S	S					P40
P41	P39		D. Monitor		113	BD 10	Sys 2 Compressor 1 Run	S	S	S	S	S	S					P41
P42	P40		D. Monitor		114	BD 11	Sys 1 Liquid Line Solenoid Valve	S	S	S	S	S	S					P42





## SECTION 9 - MAINTENANCE

### GENERAL REQUIREMENTS

The units have been designed to operate continuously, provided they are regularly maintained and operated within the limitations given in this manual. Each unit should be included in a routine schedule of daily maintenance checks by the operator/customer, backed up by regular service inspection and maintenance visits by a suitably qualified Service Engineer.

It is entirely the responsibility of the owner to provide for these regular maintenance requirements and/or enter into a maintenance agreement with a Johnson Controls service organization to protect the operation of the unit. If damage or a system failure occurs due to improper maintenance during the warranty period, Johnson Controls shall not be liable for costs incurred to return the unit to satisfactory condition.

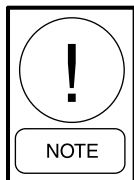

*This “Maintenance” section applies to the basic unit only and may, on individual contracts, be supplemented by additional requirements to cover any modifications or ancillary equipment as applicable.*



*The “Safety” section of this manual should be read carefully before attempting any maintenance operations on the unit.*

### Daily Maintenance

The following maintenance checks should be carried out on a daily basis by the operator/customer. Please note that the units are not generally user serviceable and no attempt should be made to rectify faults or problems found during daily checks unless competent and equipped to do so. If in any doubt, contact your local Johnson Controls Service Agent.

### Unit Status

Press the ‘STATUS’ key on the keypad and ensure no fault messages are displayed.

### Refrigerant Leaks

Visually check the heat exchangers, compressors and pipework for damage and gas leaks.

### Operating Conditions

Read the operating pressures and temperatures at the control panel using the display keys and check that these are within the operating limitations given in the manual.

### Compressor Oil Level

Check the compressor oil level after the compressor has been operating on ‘FULL LOAD’ for approximately half an hour. The oil level should be between the upper and lower sight glasses on the oil separators.

### Refrigerant Charge

When a system starts up, or sometimes after a change of capacity, a flow of bubbles will be seen in the liquid line sight glass. After a few minutes of stable operation, the bubbles should clear leaving just liquid refrigerant showing in the sight glass.

### Scheduled Maintenance

The maintenance operations detailed in the following table should be carried out on a regular basis by a suitably qualified Service Engineer. It should be noted that the interval necessary between each ‘minor’ and ‘major’ service can vary depending on, for instance, application, site conditions and expected operating schedule. Normally a ‘minor’ service should be carried out every three to six months and a ‘major’ service once a year. It is recommended that your local Johnson Controls Service Center is contacted for recommendations for individual sites.

### Chiller / Compressor Operating Log

A Chiller/Compressor Operating Log is supplied on Page 329 for logging compressor and chiller operating data.

**R-134A CONVERSION TABLES**

The following table can be used for converting R-134A pressures to their equivalent saturated temperatures.

**TABLE 30 - R-134A PRESSURE TO SATURATED TEMPERATURE CONVERSION**

<b>PRESSURE PSIG (BAR)</b>	<b>DEW POINT TEMP. °F (°C)</b>	<b>PRESSURE PSIG (BAR)</b>	<b>DEW POINT TEMP. °F (°C)</b>	<b>PRESSURE PSIG (BAR)</b>	<b>DEW POINT TEMP. °F (°C)</b>
0.0 (0)	-14.9 (-26.1)	135.0 (9.31)	105.0 (40.6)	270.0 (18.62)	152.0 (66.7)
5.0 (.34)	-3.0 (-19.4)	140.0 (9.65)	107.2 (41.8)	275.0 (18.96)	153.4 (67.4)
10.0 (.69)	6.7 (-14.1)	145.0 (10.0)	109.4 (43)	280.0 (19.31)	154.7 (68.2)
15.0 (1.03)	14.9 (-9.5)	150.0 (10.34)	111.5 (44.2)	285.0 (19.65)	156.1 (68.9)
20.0 (1.38)	22.2 (-5.4)	155.0 (10.69)	113.6 (45.3)	290.0 (19.99)	157.4 (69.7)
25.0 (1.72)	28.7 (-1.8)	160.0 (11.03)	115.6 (46.4)	295.0 (20.34)	158.7 (70.4)
30.0 (2.07)	34.6 (1.4)	165.0 (11.38)	117.6 (47.6)	300.0 (20.68)	160.0 (71.1)
35.0 (2.41)	40.0 (4.4)	170.0 (11.72)	119.6 (48.7)	305.0 (21.03)	161.3 (71.8)
40.0 (2.76)	45.0 (7.2)	175.0 (12.07)	121.5 (49.7)	310.0 (21.37)	162.5 (72.5)
45.0 (3.10)	49.6 (9.8)	180.0 (12.41)	123.3 (50.7)	315.0 (21.72)	163.8 (73.2)
50.0 (3.45)	54.0 (12.2)	185.0 (12.76)	125.2 (51.8)	320.0 (22.06)	165.0 (73.9)
55.0 (3.79)	58.1 (14.5)	190.0 (13.10)	126.9 (52.7)	325.0 (22.41)	166.2 (74.6)
60.0 (4.14)	62.0 (16.7)	195.0 (13.44)	128.7 (53.7)	330.0 (22.75)	167.4 (75.2)
65.0 (4.48)	65.7 (18.7)	200.0 (13.79)	130.4 (54.7)	335.0 (23.10)	168.6 (75.9)
70.0 (4.83)	69.2 (20.7)	205.0 (14.13)	132.1 (55.6)	340.0 (23.44)	169.8 (76.6)
75.0 (5.17)	72.6 (22.6)	210.0 (14.48)	133.8 (56.6)	345.0 (23.79)	171.0 (77.2)
80.0 (5.52)	75.9 (24.4)	215.0 (14.82)	135.5 (57.5)	350.0 (24.13)	172.1 (77.8)
85.0 (5.86)	79.0 (26.1)	220.0 (15.17)	137.1 (58.4)	355.0 (24.48)	173.3 (78.5)
90.0 (6.21)	82.0 (27.8)	225.0 (15.51)	138.7 (59.3)	360.0 (24.82)	174.4 (79.1)
95.0 (6.55)	84.9 (29.4)	230.0 (15.86)	140.2 (60.1)	365.0 (25.17)	175.5 (79.7)
100.0 (6.89)	87.7 (30.9)	235.0 (16.20)	141.8 (61)	370.0 (25.51)	176.6 (80.3)
105.0 (7.24)	90.4 (32.4)	240.0 (16.55)	143.3 (61.8)	375.0 (25.86)	177.7 (80.9)
110.0 (7.58)	93.0 (33.9)	245.0 (16.89)	144.8 (62.3)	380.0 (26.20)	178.8 (81.6)
115.0 (7.93)	95.5 (35.3)	250.0 (17.24)	146.3 (63.5)	385.0 (26.54)	179.9 (82.2)
120.0 (8.27)	98.0 (36.7)	255.0 (17.58)	147.7 (64.3)	390.0 (26.89)	180.9 (82.7)
125.0 (8.62)	100.4 (38)	260.0 (17.93)	149.2 (65.1)	395.0 (27.23)	182.0 (83.3)
130.0 (8.96)	102.7 (39.3)	265.0 (18.27)	150.6 (65.9)	400.0 (27.58)	183.0 (83.9)



## MAINTENANCE REQUIREMENTS FOR YCIV CHILLERS

BY JOHNSON CONTROLS

PROCEDURE	WEEKLY	QUARTERLY	SEMI-ANNUALLY	ANNUALLY	EVERY 5 YEARS	EVERY * HOURS
Check Oil Level in Oil Separator Sight Glass.	X					
Check Liquid Line Sight Glass/ Moisture Indicator.	X					
Record System Operating Temperatures & Pressures.	X					
Check Condenser Coils for dirt / debris and clean as necessary.	X					
Check Programmable Operating Setpoints and Safety Cutouts. Assure they are correct for the application.		X				
Check Compressor and Evaporator Heater operation.		X				
Check for dirt in the Panel. Check Door Gasket sealing integrity.		X				
**Check Superheat on the Evaporator and the Economizer feed to the Compressor.			X			
**Check Condenser Subcooling.			X			
**Leak check the Chiller.			X			
**Sample Compressor Oil, check for Acid, and replace if necessary.				X		
**Disconnect Power Source and Lock Out. Check tightness of Power Wiring connections.				X		
Check Glycol concentration on Low Temp. or other applications where freezing may be a problem.				X		
VSD Glycol Change.					X	

\* Reserved for customer use for any special site requirements.

\*\*This procedure must be performed at the specific time by an industry certified technician who has been trained and qualified to work on this type of equipment. A record of this procedure be successfully carried out should be maintained on file by the equipment owner should proof of adequate maintenance be required at a later date for warranty purposes.

## TROUBLESHOOTING GUIDE

(Always remove power to the chiller and assure the DC Bus voltage has bled off)

PROBLEM	POSSIBLE CAUSE	ACTION
<b>No Display on Control Panel. Unit will NOT Run.</b>	Supply to the Panel is missing.	High Voltage to the Chiller is missing.
		Check 1FU, 2FU, 4FU, 5FU 17FU, or 19FU.
		Check 2T or 10T Transformer.
	Line Fuse is blown.	Check Fuses.
	Chiller Control Board is defective.	Replace Chiller Control Board
	Display Board defective.	Replace Display Board
<b>Line Fuse Blows.</b>	SCR Diode Module is defective.	Check SCR/Diode Module.
	IBGT Module is defective.	Check IBGT Module.
	VSD Logic Board is defective.	Replace VSD Logic Board.
	SCR Trigger Board is defective	Replace SCR Trigger Board.
<b>Chiller Fault: LOW AMBIENT TEMPERATURE</b>	Ambient temperature is lower than the programmed operating limit.	Check the programmed cutout and determine if it is programmed correctly
	Ambient Sensor is defective.	Check the panel against the thermometer reading of ambient temperature
<b>Chiller Fault: HIGH AMBIENT TEMPERATURE</b>	Ambient Temperature is above the maximum operating limit.	Check outside air temperature.
	Ambient Sensor is defective.	Check the Panel Display against Thermometer reading of Ambient Temperature at the sensor.
<b>Chiller Fault: LOW LEAVING CHILLED LIQUID</b>	Leaving chilled liquid temperature drops faster than the unit can unload.	Check for restricted flow.
		Check for rapid flow changes.
		Water loop is too small.
		Flow is below minimum for chiller.
	Chilled Water Sensor is defective.	Check Sensor against Temp. Gauge in water line.
		Check Sensor for intermittent operation.
		Check Wiring for shorts or opens.
<b>System Fault: CONTROL VOLTAGE</b>	System Fuse is blown.	Check respective system Fuse 20FU or 21FU.
<b>System Fault: HIGH OIL TEMPERATURE</b>	Oil Temperature Sensor is defective.	Check Sensor with infrared to determine if reading is reasonable.
	Condenser Fans NOT operating or running backwards.	Check Fans.
	Coils dirty.	Check and clean Coils.

## TROUBLESHOOTING GUIDE (CONT'D)

(Always remove power to the chiller and assure the DC Bus voltage has bled off)

PROBLEM	POSSIBLE CAUSE	ACTION
<b>System Fault: HIGH DISCHARGE PRESSURE</b>	Coils dirty.	Check and clean coils.
	Coils are damaged.	Comb out fins.
	Fans NOT operating.	Check fan fuses.
		Check fan rotation.
		Check fan motor/blade.
System is overcharged.	Remove charge and check subcooling.	
<b>System Fault: HIGH DISCHARGE TEMPERATURE</b>	Discharge Temperature Sensor is defective.	Check Sensor.
	Condenser Fans NOT operating or are running backwards.	Check Fans.
	Coils dirty.	Check and clean Coils.
	High Superheat.	Measure Superheat with gauges and thermocouple. Determine cause.
<b>System Fault: HIGH MOTOR TEMPERATURE</b>	High Motor temperature input from one of the sensors	Refrigerant charge low. Check subcooling.
		Excess charge in system, High discharge pressure. Check subcooling.
		High Superheat. Drain/Feed Valves NOT controlling. Isolate cause.
		Motor Sensor reading incorrectly. Program panel to ignore a single sensor.
		Economizer Solenoid energized at low speeds. Valve is leaking through.
<b>System Fault: LOW SUCTION PRESSURE</b>	Low charge.	Check subcooling.
	Transducer reads incorrectly.	Check transducer against a gauge.
	Suction Temp. Sensor reads incorrectly.	Check sensor against a thermocouple.
	Low flow.	Check flow.
	Feed or Drain Valve NOT operating	Check Feed and Drain Valve operation. Check superheat.
	Feed or Drain Valve defective.	Check Feed and Drain Valve operation. Check superheat.
<b>System Fault: DISCHARGE PRESSURE LIMITING</b>	Discharge Transducer is defective.	Check transducer against a gauge.
	Ambient Temp. very high.	Normal operation.
	Fans NOT operating.	Check fan operation.
	Remote or local discharge pressure load limiting is programmed.	Normal operation.

**TROUBLESHOOTING GUIDE (CONT'D)**

(Always remove power to the chiller and assure the DC Bus voltage has bled off)

<b>PROBLEM</b>	<b>POSSIBLE CAUSE</b>	<b>ACTION</b>
<b>System Fault: MOTOR CURRENT LIMITING</b>	High motor current has activated current limiting	Ambient temperature is high, normal response from controller
		Remote or panel limiting is in effect, Normal response.
		Excess charge in system, adjust charge.
		Condenser coils dirty, Clean condenser.
		Fans NOT operating, Check fans.
<b>VSD Fault: High Baseplate Temperature</b>	Coolant level low.	Add coolant.
	Glycol Pump is defective.	Replace Glycol Pump.
	VSD Board is defective	Replace VSD Logic Board.
	IGBT Module is defective.	Check defective IGBT Module.
<b>VSD Fault: Low DC Bus Voltage</b>	SCR / Diode Module is defective.	Check SCR / Diode Module.
	SCR Trigger Board is defective.	Check SCR Trigger Board.

**EVACUATING A SYSTEM**

If a system or a portion of a system needs to be evacuated, it should be evacuated to a minimum of 500 microns. The system should then be able to hold the vacuum for 10 minutes with a maximum rise of 50 microns. If the system is not able to hold a vacuum, re-check the system for leaks.

## LIMITED WARRANTY

### Warranty on New Equipment

Johnson Controls warrants all equipment and associated factory supplied materials, or start-up services performed by Johnson Controls in connection therewith, against defects in workmanship and material for a period of eighteen (18) months from date of shipment. Subject to the exclusions listed below, Johnson Controls, at its option, will repair or replace, FOB point of shipment, such YORK products or components as it finds defective.

Exclusions - Unless specifically agreed to in the contract documents, this warranty does not include the following costs and expenses:

1. Labor to remove or reinstall any equipment, materials, or components.
2. Shipping, handling, or transportation charges.
3. Cost of refrigerants.

No warranty repairs or replacements will be made until payment for all equipment, materials, or components has been received by Johnson Controls.

### Warranty on Reconditioned or Replacement Materials

Except for reciprocating compressors, which Johnson Controls warrants for a period of one year from date of shipment, Johnson Controls warrants reconditioned or replacement materials, or start-up services performed by Johnson Controls in connection therewith, against defects in workmanship or material for a period of ninety (90) days from date of shipment. Subject to the exclusions listed below, Johnson Controls, at its option, will repair or replace, FOB point of shipment, such materials or parts as Johnson Controls finds defective. However, where reconditioned or replacement materials or parts are placed on equipment still under the original new equipment warranty, then such reconditioned or replacement parts are warranted only until the expiration of such original new equipment warranty.

Exclusions - Unless specifically agreed to in the contract documents, this warranty does not include the following costs and expenses:

1. Labor to remove or reinstall any equipment, materials, or components.
2. Shipping, handling, or transportation charges.
3. Cost of refrigerant.

No warranty repairs or replacements will be made until payment for all equipment, materials, or components has been received by Johnson Controls.

### All Warranties and Guarantees Are Void If:

1. Equipment is used with refrigerants, oil, or anti-freeze agents other than those authorized by Johnson Controls.
2. Equipment is used with any material or any equipment such as evaporators, tubing, other low side equipment, or refrigerant controls not approved by Johnson Controls.
3. Equipment has been damaged by freezing because it is not properly protected during cold weather, or damaged by fire or any other conditions not ordinarily encountered.
4. Equipment is not installed, operated, maintained and serviced in accordance with instructions issued by Johnson Controls.
5. Equipment is damaged due to dirt, air, moisture, or other foreign matter entering the refrigerant system.
6. Equipment is not properly stored, protected or inspected by the customer during the period from date of shipment to date of initial start.
7. Equipment is damaged due to acts of GOD, abuse, neglect, sabotage, or acts of terrorism.

THIS WARRANTY IS IN LIEU OF ALL OTHER WARRANTIES AND LIABILITIES, EXPRESS OR IMPLIED IN LAW OR IN FACT, INCLUDING THE WARRANTIES OF MERCHANTABILITY AND FITNESS FOR A PARTICULAR PURPOSE. THE WARRANTIES CONTAINED HEREIN SET FORTH BUYER'S SOLE AND EXCLUSIVE REMEDY IN THE EVENT OF A DEFECT IN WORKMANSHIP OR MATERIALS. IN NO EVENT SHALL JOHNSON CONTROLS LIABILITY FOR DIRECT OR COMPENSATORY DAMAGES EXCEED THE PAYMENTS RECEIVED BY JOHNSON CONTROLS FROM BUYER FOR THE MATERIALS OR EQUIPMENT INVOLVED. NOR SHALL JOHNSON CONTROLS BE LIABLE FOR ANY SPECIAL, INCIDENTAL, OR CONSEQUENTIAL DAMAGES. THESE LIMITATIONS ON LIABILITY AND DAMAGES SHALL APPLY UNDER ALL THEORIES OF LIABILITY OR CAUSES OF ACTION, INCLUDING, BUT NOT LIMITED TO, CONTRACT, WARRANTY, TORT (INCLUDING NEGLIGENCE) OR STRICT LIABILITY. THE ABOVE LIMITATIONS SHALL INURE TO THE BENEFIT OF JOHNSON CONTROLS SUPPLIERS AND SUBCONTRACTORS.

**CHILLED LIQUID AND SUCTION TEMPERATURE  
SENSOR INPUT VOLTAGE**

**TABLE 31 - TEMPERATURE INPUT VOLTAGE SENSOR (MEASURED SIGNAL TO SHIELD AT THE SENSOR)**

TEMP. (°F)	VOLTAGE	TEMP. (°F)	VOLTAGE	TEMP. (°F)	VOLTAGE
16.1	1.52	35.9	2.19	55.6	2.85
16.7	1.54	36.5	2.21	56.3	2.87
17.3	1.56	37.0	2.23	56.9	2.89
17.9	1.58	37.6	2.25	57.5	2.91
18.5	1.60	38.2	2.27	58.1	2.93
19.1	1.62	38.7	2.29	58.7	2.95
19.7	1.64	39.3	2.30	59.4	2.97
20.3	1.66	39.9	2.32	60.0	2.99
20.9	1.68	40.4	2.34	60.6	3.01
21.5	1.70	41.0	2.36	61.3	3.03
22.1	1.72	41.6	2.38	61.9	3.05
22.7	1.74	42.1	2.40	62.5	3.07
23.3	1.76	42.7	2.42	63.2	3.09
23.9	1.78	43.3	2.44	63.8	3.11
24.5	1.80	43.9	2.46	64.5	3.13
25.0	1.82	44.4	2.48	65.1	3.14
25.6	1.84	45.0	2.50	65.8	3.16
26.2	1.86	45.6	2.52	66.5	3.18
26.8	1.88	46.2	2.54	67.1	3.20
27.3	1.90	46.7	2.56	67.8	3.22
27.9	1.91	47.3	2.58	68.5	3.24
28.5	1.93	47.9	2.60	69.2	3.26
29.0	1.95	48.5	2.62	69.9	3.28
29.6	1.97	49.1	2.64	70.6	3.30
30.2	1.99	49.7	2.66	71.3	3.32
30.8	2.01	50.3	2.68	72.0	3.34
31.3	2.03	50.8	2.70	72.7	3.36
31.9	2.05	51.4	2.71	73.4	3.38
32.5	2.07	52.0	2.73	74.2	3.40
33.0	2.09	52.6	2.75	74.9	3.42
33.6	2.11	53.2	2.77		
34.2	2.13	53.8	2.79		
34.8	2.15	54.5	2.81		
35.3	2.17	55.0	2.83		

**TABLE 32 - OUTSIDE AIR TEMPERATURE SENSOR INPUT VOLTAGE  
(MEASURED SIGNAL TO SHIELD AT THE SENSOR)**

TEMP. (°F)	VOLTAGE	TEMP. (°F)	VOLTAGE	TEMP. (°F)	VOLTAGE
0.24	0.68	49.8	2.00	93.3	3.31
1.79	0.71	50.7	2.03	94.4	3.34
3.30	0.74	51.6	2.06	65.6	3.37
4.76	0.77	52.5	2.09	96.8	3.40
6.19	0.80	53.4	2.11	98.0	3.43
7.58	0.83	54.3	2.14	99.2	3.46
8.94	0.85	55.3	2.17	100.4	3.49
10.3	0.88	56.2	2.20	101.6	3.52
11.6	0.91	57.1	2.23	102.9	3.55
12.8	0.94	58.0	2.26	104.2	3.57
14.1	0.97	58.9	2.29	105.5	3.60
15.3	1.00	59.8	2.32	106.8	3.63
16.5	1.03	60.7	2.35	108.1	3.66
17.7	1.06	61.6	2.38	109.5	3.69
18.9	1.09	62.6	2.41	110.9	3.72
20.0	1.12	63.5	2.44	112.3	3.75
21.2	1.15	64.4	2.47	113.8	3.78
22.3	1.18	65.3	2.50	115.2	3.81
23.4	1.21	66.3	2.52	116.7	3.84
24.4	1.24	67.2	2.55	118.3	3.87
25.5	1.26	68.1	2.58	119.9	3.90
26.6	1.26	69.1	2.61	121.5	3.93
27.6	1.32	70.0	2.64	123.2	3.96
28.7	1.35	70.9	2.67	124.9	3.98
29.7	1.38	71.9	2.70	126.6	4.01
30.7	1.41	72.8	2.73	128.4	4.04
31.7	1.44	73.8	2.76	130.3	4.07
32.7	1.47	74.8	2.76		
33.7	1.50	75.8	2.82		
34.7	1.53	76.7	2.85		
35.7	1.56	77.7	2.88		
36.7	1.59	78.7	2.91		
37.6	1.62	79.7	2.93		
38.6	1.65	80.7	2.96		
39.6	1.67	81.7	2.99		
40.5	1.70	82.7	3.02		
41.4	1.73	83.6	3.05		
42.4	1.76	84.6	3.08		
43.3	1.79	85.7	3.11		
44.3	1.82	86.7	3.13		
45.2	1.85	87.8	3.16		
46.1	1.88	88.9	3.19		
47.0	1.91	90.1	3.22		
48.0	1.94	91.1	3.25		
48.9	1.97	92.2	3.28		

**TABLE 33 - PRESSURE TRANSDUCER OUTPUT VOLTAGE (MEASURED SIGNAL TO RETURN AT THE TRANSDUCER)**

Suction Pressure Transducer (125 PSIG)		Discharge Pressure Transducer (275 PSIG)		Discharge Pressure Transducer (275 PSIG)	
Pressure	Voltage	Pressure	Voltage	Pressure	Voltage
0	0.50	0	0.50	140	2.54
5	0.66	5	0.57	145	2.61
10	0.82	10	0.65	150	2.68
15	0.98	15	0.72	155	2.75
20	1.14	20	0.79	160	2.83
25	1.30	25	0.86	165	2.90
30	1.46	30	0.94	170	2.97
35	1.62	35	1.01	175	3.05
40	1.78	40	1.08	180	3.12
45	1.94	45	1.15	185	3.19
50	2.10	50	1.23	190	3.26
55	2.26	55	1.30	195	3.34
60	2.42	60	1.37	200	3.41
65	2.58	65	1.45	205	3.48
70	2.74	70	1.52	210	3.55
75	2.90	75	1.59	215	3.63
80	3.06	80	1.66	220	3.70
85	3.22	85	1.74	225	3.77
90	3.38	90	1.81	230	3.85
95	3.54	95	1.88	235	3.92
100	3.70	100	1.95	240	3.99
105	3.86	105	2.03	245	4.06
110	4.02	110	2.10	250	4.14
115	4.18	115	2.17	255	4.21
120	4.34	120	2.25	260	4.28
125	4.50	125	2.32	265	4.35
		130	2.39	270	4.43
		135	2.46	275	4.50

**TABLE 34 - MOTOR TEMPERATURE SENSOR RESISTANCE (CHECK AT THE MOTOR)**

Temp. (°C)	Rnominal (Ohms)	Rtol (± %)	Rmin (Ohms)	Rmax (Ohms)
-20	97,062	5.00	92,209	101,915
-15	77,941	4.60	69,586	76,296
-10	55,391	4.20	52,996	57,643
-5	42,324	3.85	40,695	43,954
0	32,654	3.50	31,511	33,797
5	25,396	3.15	24,596	26,196
10	19,903	2.80	19,346	20,461
15	15,713	2.50	15,321	16,106
20	12,493	2.20	12,218	12,768
25	10,000	2.00	9,800	10,200
30	8,056	2.40	7,863	8,250
35	6,531	2.70	6,354	6,707
40	5,326	3.00	5,166	5,485
45	4,368	3.25	4,226	4,510
50	3,602	3.50	3,476	3,728
55	2,986	3.75	2,874	3,098
60	2,488	4.00	2,389	2,588
65	2,083	4.25	1,995	2,172
70	1,753	4.50	1,674	1,832
75	1,481	4.75	1,411	1,551
80	1,257	5.00	1,194	1,321
85	1,071	5.20	1,016	1,127
90	916.9	5.40	867.4	966.4
95	787.7	5.60	743.6	831.9
100	679.3	5.80	639.9	718.7
105	587.9	6.00	552.6	623.2
110	510.6	6.20	479.9	542.3
115	445.0	6.40	416.5	473.5
120	389.0	6.60	363.4	414.7
125	341.2	6.70	318.4	364.1
130	300.2	6.90	279.5	320.9
135	264.9	7.10	246.1	283.7
140	234.4	7.30	217.3	251.5
145	208.0	7.40	192.6	223.3
150	185.0	7.50	171.1	198.9

**TABLE 35 - COMPRESSOR MOTOR OVERLOAD SETTINGS AND MAX. VSD FREQUENCY**

**2 COMP CHILLER MODELS WITH STANDARD (PIN 52 = X) AND ULTRA QUIET FANS (PIN 52 = L)**

CHILLER MODEL (2 COMP) W/ STD & UQ FANS	CHILLER NAME- PLATE VOLTAGE (VAC)	COMPRESSOR 1 OVERLOAD SETTING (AMPS)	COMPRESSOR 2 OVERLOAD SETTING (AMPS)	MAXIMUM VSD FREQUENCY (HZ)
YCIV0590EA/VA	400	255	255	186
YCIV0600SA/PA	400	260	260	200
YCIV0630EA/VA	400	249	261	200
YCIV0650SA/PA	400	289	254	182
YCIV0700EA/VA	400	289	246	192
YCIV0720SA/PA	400	289	261	200
YCIV0760EA/VA	400	289	289	182
YCIV0800EA/VA	400	289	289	192
YCIV0770SA/PA	400	289	289	186
YCIV0830EA/VA	400	289	289	200
YCIV0840SA/PA	400	289	289	200
YCIV0930EA/VA	400	345	299	200
YCIV0920SA/PA	400	345	314	200
YCIV1000SA/PA	400	345	345	200

**2 COMP CHILLER MODELS WITH 2-SPEED FANS**

CHILLER MODEL (2 COMP) W/ 2-SPD FANS	CHILLER NAME- PLATE VOLTAGE (VAC)	COMPRESSOR 1 OVERLOAD SETTING (AMPS)	COMPRESSOR 2 OVERLOAD SETTING (AMPS)	MAXIMUM VSD FREQUENCY (HZ)
YCIV0590EA/VA	400	262	262	186
YCIV0600SA/PA	400	268	268	200
YCIV0630EA/VA	400	255	270	200
YCIV0650SA/PA	400	289	261	182
YCIV0700EA/VA	400	289	252	192
YCIV0720SA/PA	400	289	270	200
YCIV0760EA/VA	400	289	289	182
YCIV0800EA/VA	400	289	289	192
YCIV0770SA/PA	400	289	289	186
YCIV0830EA/VA	400	289	289	200
YCIV0840SA/PA	400	289	289	200
YCIV0930EA/VA	400	345	309	200
YCIV0920SA/PA	400	345	328	200
YCIV1000SA/PA	400	345	345	200

NOTE: Overload settings are based on Chiller Model and Condenser Fan Option

**TABLE 35 - COMPRESSOR MOTOR OVERLOAD SETTINGS AND MAX. VSD FREQUENCY (CONT'D)****2 COMP CHILLER MODELS WITH HIGH HEAD/HIGH STATIC FANS (PIN 52 = H)**

CHILLER MODEL (2 COMP) W/ HH/HS FANS	CHILLER NAME- PLATE VOLTAGE (VAC)	COMPRESSOR 1 OVERLOAD SETTING (AMPS)	COMPRESSOR 2 OVERLOAD SETTING (AMPS)	MAXIMUM VSD FREQUENCY (HZ)
YCIV0590EA/VA	400	255	255	186
YCIV0600SA/PA	400	260	260	200
YCIV0630EA/VA	400	249	261	200
YCIV0650SA/PA	400	289	254	182
YCIV0700EA/VA	400	289	246	192
YCIV0720SA/PA	400	289	261	200
YCIV0760EA/VA	400	289	289	182
YCIV0800EA/VA	400	289	289	192
YCIV0770SA/PA	400	289	289	186
YCIV0830EA/VA	400	289	289	200
YCIV0840SA/PA	400	289	289	200
YCIV0930EA/VA	400	345	299	200
YCIV0920SA/PA	400	345	314	200
YCIV1000SA/PA	400	345	345	200

9

**3 COMP CHILLER MODELS WITH STANDARD (PIN 52 = X) AND ULTRA QUIET FANS (PIN 52 = L)**

CHILLER MODEL (3 COMP) W/ STD & UQ FANS	CHILLER NAME- PLATE VOLTAGE (VAC)	COMPRESSOR 1 OVERLOAD SETTING (AMPS)	COMPRESSOR 2 OVERLOAD SETTING (AMPS)	COMPRESSOR 3 OVERLOAD SETTING (AMPS)	MAXIMUM VSD FREQUENCY (HZ)
YCIV1050EA/VA	400	289	289	253	182
YCIV1070SA/PA	400	289	289	255	186
YCIV1120EA/VA	400	289	289	289	178
YCIV1180SA/PA	400	289	289	289	188
YCIV1220EA/VA	400	289	289	289	192
YCIV1340SA/PA	400	314	314	338	200
YCIV1380EA/VA	400	338	338	293	192
YCIV1500SA/PA	400	338	338	338	200

NOTE: Overload settings are based on Chiller Model and Condenser Fan Option

**TABLE 35 - COMPRESSOR MOTOR OVERLOAD SETTINGS AND MAX. VSD FREQUENCY (CONT'D)**

**3 COMP CHILLER MODELS WITH 2-SPEED FANS**

CHILLER MODEL (3 COMP) W/ 2-SPD FANS	CHILLER NAME- PLATE VOLTAGE (VAC)	COMPRESSOR 1 OVERLOAD SETTING (AMPS)	COMPRESSOR 2 OVERLOAD SETTING (AMPS)	COMPRESSOR 3 OVERLOAD SETTING (AMPS)	MAXIMUM VSD FREQUENCY (HZ)
YCIV1050EA/VA	400	289	289	260	182
YCIV1070SA/PA	400	289	289	262	186
YCIV1120EA/VA	400	289	289	289	178
YCIV1180SA/PA	400	289	289	289	188
YCIV1220EA/VA	400	289	289	289	192
YCIV1340SA/PA	400	328	328	338	200
YCIV1380EA/VA	400	338	338	304	192
YCIV1500SA/PA	400	338	338	338	200

**3 COMP CHILLER MODELS WITH HIGH HEAD/HIGH STATIC FANS (PIN 52 = H)**

CHILLER MODEL (3 COMP) W/ HH/HS FANS	CHILLER NAME- PLATE VOLTAGE (VAC)	COMPRESSOR 1 OVERLOAD SETTING (AMPS)	COMPRESSOR 2 OVERLOAD SETTING (AMPS)	COMPRESSOR 3 OVERLOAD SETTING (AMPS)	MAXIMUM VSD FREQUENCY (HZ)
YCIV1050EA/VA	400	289	289	253	182
YCIV1070SA/PA	400	289	289	255	186
YCIV1120EA/VA	400	289	289	289	178
YCIV1180SA/PA	400	289	289	289	188
YCIV1220EA/VA	400	289	289	289	192
YCIV1340SA/PA	400	314	314	338	200
YCIV1380EA/VA	400	338	338	293	192
YCIV1500SA/PA	400	338	338	338	200

NOTE: Overload settings are based on Chiller Model and Condenser Fan Option

## PRINTER WIRING

A “serial” printer may be connected to the TB1 connector on the Chiller Logic Board for the purposes of logging data and troubleshooting. Weightronix Imp-2600, Seiko DPU-414, and Okidata Microline 184 printers or equivalents may be used.

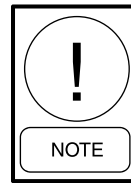

***Printer designs change rapidly. The user should use the printer manual for the respective printer for set-up and wiring.***

Data from the chiller is transmitted at 1200 baud. Wiring diagrams for cables are shown below:

### OKIDATA MICROLINE 184

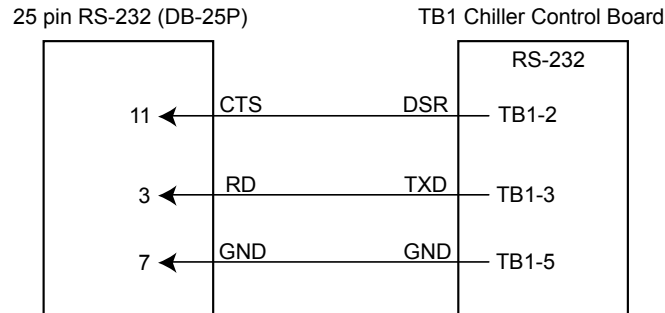

### SEIKO DPU-414

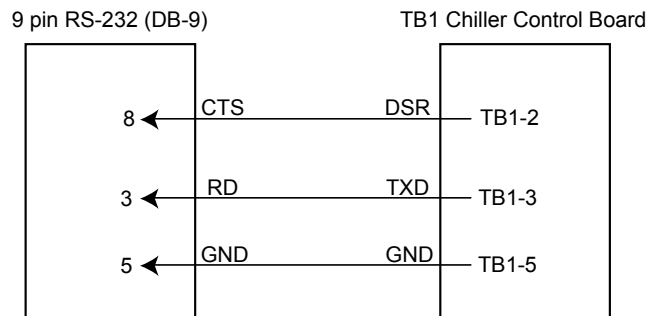

### WEIGHTRONIX IMP-24, MODEL 2600

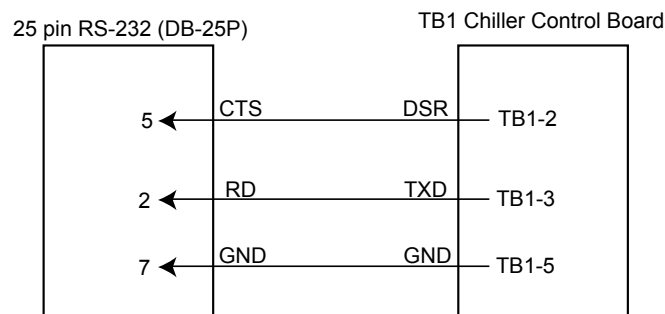

Id10638

**FIG. 60 - PRINT CABLE - CHILLER TO SERIAL PRINTER**

**Printer Cables**

Printer cables should be shielded coaxial, #18AWG, stranded wire cables, not to exceed 50' in length. On long cable runs or whenever permanent installation is required, the shield of the coax should be tied to the chassis ground at the chiller only, not at the printer.

**Printer Setup**

The following information may be useful for quick set up of a printer. Specific printer manuals should be utilized, if problems occur, since functions often change as new versions of printers are introduced with enhancements requiring control code, signal programming, and wiring changes.

**Okidata 184**

**Control Board Switch Settings**

- SW1 – ON: Unslashed 0
- 2 – OFF: Unslashed 0
- 3 – OFF: Unslashed 0
- 4 – OFF: Form Length 11 in.
- 5 – ON: Form Length 11 in.
- 6 – OFF: Auto Line feed OFF
- 7 – ON: 8 bit data
- 8 – OFF: Enable front panel

**With Super Speed Serial Board**

- SW1-1 – ON: Odd or even parity
- 1-2 – ON: No parity
- 1-3 – ON: 8 bit data
- 1-4 – ON: Protocol ready/busy
- 1-5 – ON: Test select
- 1-6 – ON: Print mode
- 1-7 – OFF: SDD(-) pin 11
- 1-8 – ON: SDD(-) pin 11
- 2-1 – ON: 1200 baud
- 2-2 – ON: 1200 baud
- 2-3 – OFF: 1200 baud
- 2-4 – OFF: DSR active
- 2-5 – ON: Buffer threshold 32 bytes
- 2-6 – ON: Busy signal 200ms
- 2-7 – ON: DTR space after power on
- 2-8 – not used

**With High Speed Serial Board**

- SW1 – OFF: (-) Low when busy
- 2 – OFF: 1200 baud
- 3 – OFF: 1200 baud
- 4 – ON: 1200 baud
- 5 – not used
- 6 – OFF: no parity
- 7 – OFF: Pin 20 and pin 11 act as busy line

**Weigh-tronix IMP 24 Model 2600**

- SW1 – OFF: 1200 baud
- 2 – ON: 1200 baud

**Seiko**

- DipSW1-1 – OFF: Input -Serial
- 1-2 – ON: Printing speed high
- 1-3 – ON: Auto loading - ON
- 1-4 – OFF: Auto LF - OFFF
- 1-5 – ON: Setting Command - Enable
- 1-6 – OFF: Printing density - 100%
- 1-7 – ON: Printing density - 100%
- 1-8 – ON: Printing density - 100%
- DipSW2-1 – ON: Printing Columns - 40
- 2-2 – ON: User Font Back-up - ON
- 2-3 – ON: Character Select - normal
- 2-4 – OFF: Zero - slash
- 2-5 – ON: International character set - American
- 2-6 – ON: International character set - American
- 2-7 – ON: International character set - American
- 2-8 – OFF: International character set - American
- DipSW3-1 – ON: Data length - bits
- 3-2 – ON: Parity Setting - no
- 3-3 – ON: Parity condition - odd
- 3-4 – ON: Busy control - H/W busy
- 3-5 – ON: Baud rate select - 1200
- 3-6 – OFF: Baud rate select - 1200
- 3-7 – ON: Baud rate select - 1200
- 3-8 – OFF: Baud rate select - 1200

## OPERATING LOG SHEET

### SITE AND CHILLER INFORMATION

JOB NAME:

\_\_\_\_\_

START DATE:

\_\_\_\_\_

LOCATION:

\_\_\_\_\_

COMPRESSOR # 1 - MODEL #:

\_\_\_\_\_

SALES ORDER #:

\_\_\_\_\_

COMPRESSOR # 2 - MODEL #:

\_\_\_\_\_

TECHNICIAN NAME:

\_\_\_\_\_

COMPRESSOR # 3 - MODEL #:

\_\_\_\_\_

CHILLER MODEL #:

\_\_\_\_\_

COMPRESSOR # 4 - MODEL #:

\_\_\_\_\_

SERIAL #:

\_\_\_\_\_

SERIAL #:

\_\_\_\_\_

### PROGRAMMED VALUES

#### CHILLED LIQUID SETPOINT

Setpoint = \_\_\_\_\_ °F(°C)

Range = +/- \_\_\_\_\_ °F(°C)

Display Language = \_\_\_\_\_

Chilled Liquid Mode = \_\_\_\_\_

Local/Remote Mode = \_\_\_\_\_

Display Units = \_\_\_\_\_

Lead/Lag Control = \_\_\_\_\_

Remote Temperature Reset = \_\_\_\_\_

Remote Current Reset = \_\_\_\_\_

#### PROGRAMMED CUTOUPS

Suction Pressure Cutout = \_\_\_\_\_ PSIG (kPa)

Low Ambient Cutout = \_\_\_\_\_ °F(°C)

Leaving Chilled Liquid Temp. Cutout =

\_\_\_\_\_ °F(°C)

High Motor Current Unload = \_\_\_\_\_ %FLA

**UNIT OPERATING TEMPERATURES AND PRESSURES**

**CHILLED LIQUID TEMPERATURES**

Entering Temp. = \_\_\_\_\_ °F(°C)

Leaving Temp. = \_\_\_\_\_ °F(°C)

**OUTDOOR AMBIENT TEMPERATURES**

OAT = \_\_\_\_\_ °F(°C)

**VSD FREQUENCY**

Actual = \_\_\_\_\_

Command = \_\_\_\_\_

**VSD BUS VOLTAGE**

Bus 1 = \_\_\_\_\_

Bus 2 = \_\_\_\_\_

**VSD INTERNAL AMBIENT TEMPERATURE**

Ambient Temp. = \_\_\_\_\_ °F(°C)

**VSD COOLING SYSTEM STATUS**

ON \_\_\_ OFF \_\_\_

**VSD IGBT BASEPLATE TEMPS**

T1 = \_\_\_\_\_ °F(°C)

T2 = \_\_\_\_\_ °F(°C)

**SYSTEM OPERATING TEMPERATURES, PRESSURES AND CURRENTS**

**SYSTEM PRESSURES**

**SYS 1   SYS 2   SYS 3   SYS 4**  
Oil   \_\_\_\_\_   \_\_\_\_\_   \_\_\_\_\_   \_\_\_\_\_ PSIG (kPa)

Suction \_\_\_\_\_ PSIG (kPa)

Discharge \_\_\_\_\_ PSIG (kPa)

**MOTOR TEMPERATURES**

**SYS 1   SYS 2   SYS 3   SYS 4**  
T1   \_\_\_\_\_   \_\_\_\_\_   \_\_\_\_\_   \_\_\_\_\_ °F(°C)

T2   \_\_\_\_\_   \_\_\_\_\_   \_\_\_\_\_   \_\_\_\_\_ °F(°C)

T3   \_\_\_\_\_   \_\_\_\_\_   \_\_\_\_\_   \_\_\_\_\_ °F(°C)

**SYSTEM TEMPERATURES**

**SYS 1   SYS 2   SYS 3   SYS 4**  
Oil   \_\_\_\_\_   \_\_\_\_\_   \_\_\_\_\_   \_\_\_\_\_ °F(°C)

Suction   \_\_\_\_\_   \_\_\_\_\_   \_\_\_\_\_   \_\_\_\_\_ °F(°C)

Discharge   \_\_\_\_\_   \_\_\_\_\_   \_\_\_\_\_   \_\_\_\_\_ °F(°C)

SAT Suction   \_\_\_\_\_   \_\_\_\_\_   \_\_\_\_\_   \_\_\_\_\_ °F(°C)

SAT Superht   \_\_\_\_\_   \_\_\_\_\_   \_\_\_\_\_   \_\_\_\_\_ °F(°C)

SAT Discharge   \_\_\_\_\_   \_\_\_\_\_   \_\_\_\_\_   \_\_\_\_\_ °F(°C)

Dsch Superht   \_\_\_\_\_   \_\_\_\_\_   \_\_\_\_\_   \_\_\_\_\_ °F(°C)

**COMPRESSOR SPEED**

**SYS 1   SYS 2   SYS 3   SYS 4**  
Speed   \_\_\_\_\_   \_\_\_\_\_   \_\_\_\_\_   \_\_\_\_\_ %

**SYSTEM CURRENT**

**SYS 1   SYS 2   SYS 3   SYS 4**  
Current   \_\_\_\_\_   \_\_\_\_\_   \_\_\_\_\_   \_\_\_\_\_ AMPS

**SYS 1   SYS 2   SYS 3   SYS 4**  
Current   \_\_\_\_\_   \_\_\_\_\_   \_\_\_\_\_   \_\_\_\_\_ %FLA

## SYSTEM OPERATING CONDITIONS

### ECONOMIZER SOLENOID STATUS

	SYS 1	SYS 2	SYS 3	SYS 4
Economizer (ON/OFF)	_____	_____	_____	_____

### FEED/DRAIN VALVE % OPEN

	SYS 1	SYS 2	SYS 3	SYS 4
Feed Valve	_____	_____	_____	_____
Drain Valve	_____	_____	_____	_____

### FLASH TANK LEVEL

	SYS 1	SYS 2	SYS 3	SYS 4
Flash Tank Level	_____	_____	_____	_____ %

### CONDENSER FAN STAGE (0-6)

	SYS 1	SYS 2	SYS 3	SYS 4
Fan Stage	_____	_____	_____	_____

### COMPRESSOR HEATER (ON/OFF)

	SYS 1	SYS 2	SYS 3	SYS 4
Comp Heater	_____	_____	_____	_____

### SYSTEM RUN TIME

	Days	Hours	Mins	Sec
System 1	_____	_____	_____	_____
System 2	_____	_____	_____	_____
System 3	_____	_____	_____	_____
System 4	_____	_____	_____	_____

### SYSTEM STARTS

	STARTS
SYSTEM 1	_____
SYSTEM 2	_____
SYSTEM 3	_____
SYSTEM 4	_____

### OIL SEPARATOR LEVEL

Check Oil Separator Oil Levels

	SYS 1		SYS 2	
Separator	#1	#2	#3	#4
Oil Level Top Glass	<input type="radio"/>	<input type="radio"/>	<input type="radio"/>	<input type="radio"/>
Oil Level Bot Glass	<input type="radio"/>	<input type="radio"/>	<input type="radio"/>	<input type="radio"/>

	SYS 3		SYS 4	
Separator	#1	#2	#3	#4
Oil Level Top Glass	<input type="radio"/>	<input type="radio"/>	<input type="radio"/>	<input type="radio"/>
Oil Level Bot Glass	<input type="radio"/>	<input type="radio"/>	<input type="radio"/>	<input type="radio"/>



*Oil Separator level should be maintained so that an oil level is between the upper and lower sight glasses.*

**WATER SYSTEM CONDITIONS**

**EVAPORATOR FLOW**

Flow Rate \_\_\_\_\_ GPM

Evap Pressure Drop \_\_\_\_\_ FT / LBS  
(Circle One)

Glycol Freeze Point \_\_\_\_\_ °F (°C)

**CONDENSER CONDITIONS**

**AIR TEMPERATURE**

Air ON Temperature \_\_\_\_\_ °F (°C)

Air OFF Temperature \_\_\_\_\_ °F (°C)

**NOTES**

---

---

---

---

---

---

---

---

---

---

**RECOMMENDED SPARE PARTS**

<b>DESCRIPTION</b>	<b>MODEL NUMBER YCIV</b>	<b>PART NUMBER</b>
Fan Motor (Standard Low Noise)	-40	024-27322-004
	-46	024-27322-007
Fan Motor (Optional Ultra Low Noise)	-40	024-34980-005
	-46	024-34980-001
Fan Blade (Standard Low Noise)	ALL	026-41594-000
Fan Blade (Optional Ultra Low Noise)	ALL	026-41942-000
Core, Dehydrator	ALL	026-37450-000
Oil, Compressor (Type "L")	R-134a	011-00592-000
Sensor, Outside Air Temperature	ALL	026-28663-001
Transducer, Pressure (0-275 psig)	ALL	025-29139-003
High Pressure Cutout (297 psig)	ALL	025-39456-000
Transducer, Suction Pressure (0-125 psig)	ALL	025-29583-001
Sensor, EWT, LWT	ALL	025-40334-000
Relay Output Board	ALL	031-02479-002
VSD Logic Board Kit	ALL	031-02507-601
Controller, Valve	ALL	031-02742-000
SCR Trigger Board	50 HZ YCIV	031-02060-002
Chiller Control Board	ALL	031-02478-002
Level Sensor	ALL	025-40274-000
Feed Drain Valve	ALL	025-41565-000

