

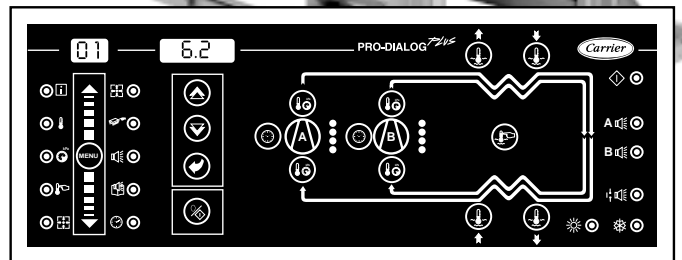

30G and 30H series PRO-DIALOG *Plus* Control

Reciprocating air- and water-cooled liquid chillers

50 Hz

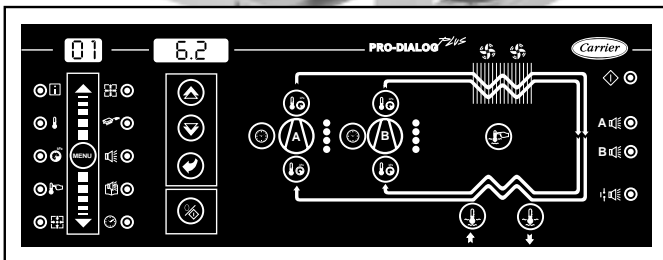

Installation, operation and maintenance
instructions



Quality Management System Approval

The cover photograph is solely for illustration, and forms no part of any offer for sale or any sale contract. The manufacturer reserves the right to change the design at any time without notice.

Table of contents

1 - SAFETY CONSIDERATIONS	4
1.1 - General	4
1.2 - Avoiding electrocution	4
2 - GENERAL DESCRIPTION	4
2.1 - General	4
2.2 - Abbreviations used	4
3 - HARDWARE DESCRIPTION	5
3.1 - General	5
3.2 - Electronic boards	5
3.3 - The controls	7
3.4 - Connections at customer's terminal block	8
4 - SETTING UP PRO-DIALOG CONTROL	11
4.1 - General	11
4.2 - Main interface	11
4.3 - Summary interface	27
5 - USING THE PRO-DIALOG CONTROL SYSTEM	28
5.1 - Start/stop control	28
5.2 - Heating/cooling selection	28
5.3 - Evaporator water pump control	28
5.4 - Control interlock contact	28
5.5 - Control point	28
5.6 - Demand limit	28
5.7 - Capacity control	29
5.8 - Determining the lead circuit	29
5.9 - Circuit loading sequence	29
5.10 - Lag compressor start-up sequence	29
5.11 - Controlling the EXV	29
5.12 - Head pressure control on air-cooled units	30
5.13 - Head pressure control on water-cooled units	30
5.14 - Condensing setpoint selection	30
5.15 - Heat reclaim module option	30
5.16 - High pressure load shedding option	31
5.17 - Pump down	31
5.18 - Master/slave assembly	31
5.19 - Controlling a Pro-Dialog unit with a System Manager	31
6 - DIAGNOSTICS - TROUBLESHOOTING	32
6.1 - General	32
6.2 - Displaying alarms	32
6.3 - Resetting alarms	32
6.4 - Alarm codes	32

1 - SAFETY CONSIDERATIONS

1.1 - General

Installation, start-up and servicing of equipment can be hazardous if factors particular to the installation are not considered: operating pressures, electrical components, voltages and the installation site itself (elevated plinths, rooftops and built-up structures).

Only highly trained and qualified installation engineers and technicians, who are fully trained on the product, are authorised to install and start up this equipment.

During all servicing operations, it is important to read, understand and follow all the recommendations and instructions given in the installation and service instructions for the product, including the tags and labels affixed to the equipment, components and any parts supplied separately, and to comply with all other relevant safety regulations.

- Apply all safety codes and practices.
- Wear safety glasses and gloves.
- Use the proper tools to move heavy objects. Move units carefully and set them down gently.

1.2 - Avoiding electrocution

Only personnel qualified in accordance with the recommendations of the IEC (International Electrotechnical Commission) may be permitted access to electrical components. It is particularly recommended that all sources of electricity to the unit be shut off before any work is begun. Shut off the main power supply at the main circuit breaker or isolator.

IMPORTANT: A label is provided on which to write the type and location of the main power isolator or circuit breaker. The label is on the front of the electrical box and must be completed in non-erasable ink on site.

IMPORTANT:

Risk of electrocution: Even when the main power isolator or circuit breaker is off, it is still possible for certain components such as crankcase heaters and trace heaters to be energised, since they are connected to a separate power source.

Risk of burns: Electrical currents cause components to get hot either temporarily or permanently. Handle power cables, electrical cables and conduits, terminal box covers and motor frames with very great care.

IMPORTANT: This equipment uses and emits electromagnetic signals. If it is not installed and used in accordance with the instructions given here, it may cause radio interference. It has been tested and shown to comply with all applicable codes regarding electromagnetic compatibility.

2 - GENERAL DESCRIPTION

2.1 - General

PRO-DIALOG Plus is a system for controlling units which use reciprocating piston compressors:

- Single or dual circuit
- Air or water-cooled condensers
- Split systems
- Non-reversible heat pumps

PRO-DIALOG Plus controls compressor start-up and demand limits needed to maintain the desired leaving temperature setpoint for water. It automatically sets the position of the electronic expansion valve (if used) to maintain constant superheat of the liquid refrigerant entering the compressor cylinders. It controls operation of the fans (on air-cooled units) or water valves (on water-cooled units) to maintain the correct head pressure in each circuit.

Safety circuits are constantly monitored by PRO-DIALOG Plus to ensure safe operation of the unit. PRO-DIALOG Plus also gives access to a Quick Test program covering all inputs and outputs.

All PRO-DIALOG Plus controls can work in accordance with three independent modes:

- Local mode: the machine is controlled by commands from the user interface.
- Remote mode: the machine is controlled by remote contacts (volt-free contacts, analogue signals).
- CCN mode: the machine is controlled by commands from the Carrier Comfort Network (CCN). In this case a data communication cable is used to connect the unit to the CCN communication bus.

The operating mode must be chosen with the Operating Type selection button described in section 4.2.2.

When the PRO-DIALOG Plus system operates autonomously (Local or Remote mode) it retains all of its own control capabilities but does not offer any of the features of the CCN network.

2.2 - Abbreviations used

In this manual the circuits are called circuit A and circuit B. The compressors in circuit A are labelled A1, A2, A3 and A4. Those in circuit B are labelled B1, B2, B3 and B4. A1 and B1 are the lead compressors.

The following abbreviations are frequently used:

- AI - Analogue Input
- AO - Analogue Output
- CCn - Operating type: CCN
- CCN - Carrier Comfort Network
- DI - Discrete Input
- DO - Discrete Output
- EXV - Electronic eXpansion Valve
- L-C1 - Operating type: Local cooling - setpoint 1
- L-C2 - Operating type: Local cooling - setpoint 2
- L-H - Operating type: Local heating
- LC1r - Operating type: Local cooling - setpoint 1 - heat reclaim
- LC2r - Operating type: Local cooling - setpoint 2 - heat reclaim

- LED - Light Emitting Diode
- LOFF- Operating type: Local off
- rEM - Operating type: by remote control contacts
- SCT - Saturated disCharge Temperature
- SIO - Standard Input/Output - internal communication bus linking the basic board to the slave boards
- SST - Saturated Suction Temperature
- TXV - Thermal eXpansion Valve

3 - HARDWARE DESCRIPTION

3.1 - General

The control system consists of at least a basic board and a user interface with, depending on the application, one or more slave boards such as compressor boards, 4xDO boards or 4xAI-2xAO boards. If used, slave boards are connected to the basic board via an internal communication bus (SIO).

3.2 - Electronic boards

3.2.1 - The basic board

This board can be used alone or in conjunction with slave boards. It holds the program that controls the machine. It continuously manages the information coming in from the various pressure and temperature sensors, and communicates with the slave boards via the SIO bus. It can also communicate with elements of the Carrier Comfort Network via the CCN bus.

When “conF” shows on the user interface, this means that the basic board must be configured. This can only be done by Carrier Service.

Power interrupt detection: The ACF contacts on J6 detect any interruption or dropout in the power supply. If the contact opens, the unit is immediately shut down and the basic board is re-initialised. This contact must therefore be normally closed when the power to the controller is switched on. After a power dropout, the unit restarts automatically without the need for an external command.

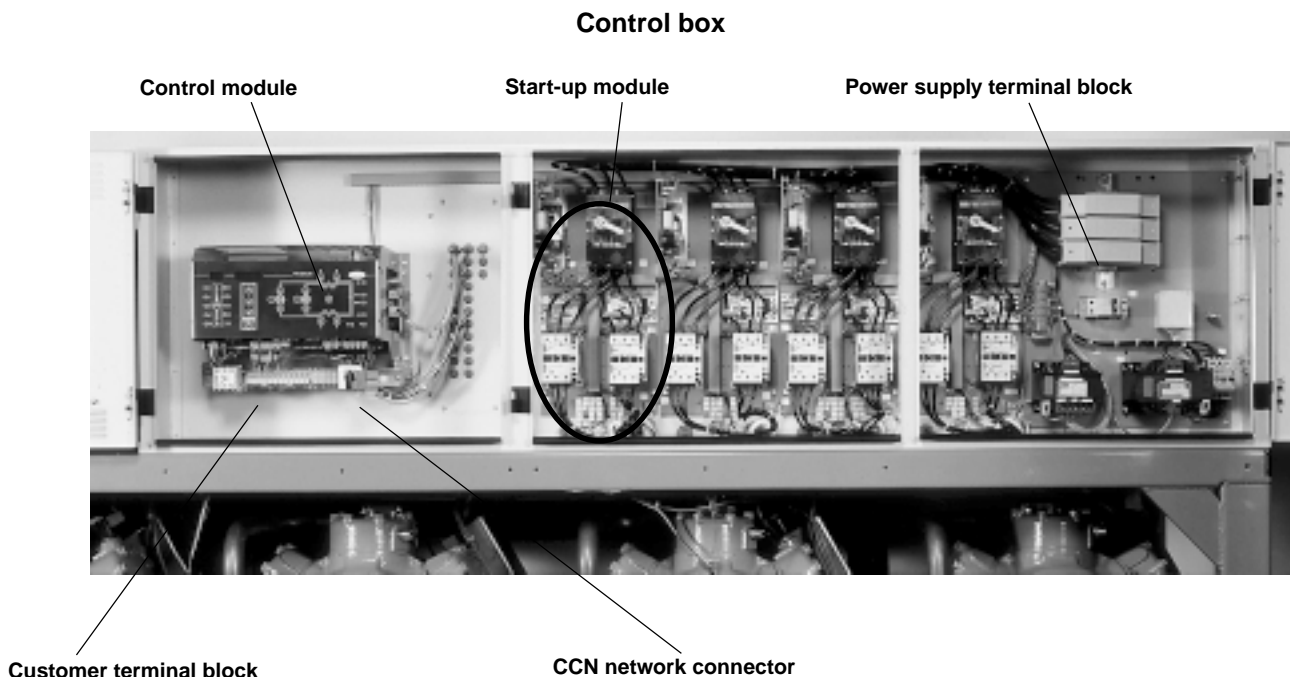

The various control components are arranged in modules within the control cabinet:

- **Control module:** This comprises the basic board, the user interface, the EXV control boards (if available) and option boards, as well as the customer’s terminal block.
- **Start-up module:** This consists of the compressor start-up boards (unit with more than two compressors) and compressor protection boards, together with the compressor circuit breakers and contactors.
- **Fan module (air-cooled unit):** Consists of one or two 4xDO boards together with the fan circuit breakers and contactors.

3.2.2 - Slave boards

- **Compressor board:** This board is used to control a compressor that is not directly controlled by the basic board (unit with more than 2 compressors). Up to eight compressor boards can be connected to the basic board.
- **4xDO board:** This board can be used to control one EXV (with the aid of an additional interface card), or various fan stages, or the valves used by the heat reclaim option.
- **4xAI-2xAO board:** This board can be used to read additional sensors (oil pressure, condensing temperature or reclaim temperature), or to control variable speed fans (air-cooled units) or condenser valves (water-cooled units).

3.2.3 - The user interface

The user interface is in two parts:

- **The main interface:** This gives access to all of the control parameters for the unit. It consists of a 2-digit primary display block and a secondary 4-digit display block with 10 LEDs and 5 buttons.
- **The summary interface:** This gives quick access to just the main control parameters for the unit. It comprises 12 buttons and 16 LEDs, and includes a schematic diagram of the unit.

3.2.4 - Connections between boards

The basic board and slave boards communicate with each other over an internal three-wire RS485 communication bus (SIO bus). These three wires link all the boards in parallel.

Terminals 1, 2 and 3 on connector J4 of the basic board are linked to terminals 1, 2 and 3 of connector J3 on the slave boards, respectively. Incorrect connection will render the system inoperative.

Internal bus wiring (between boards)

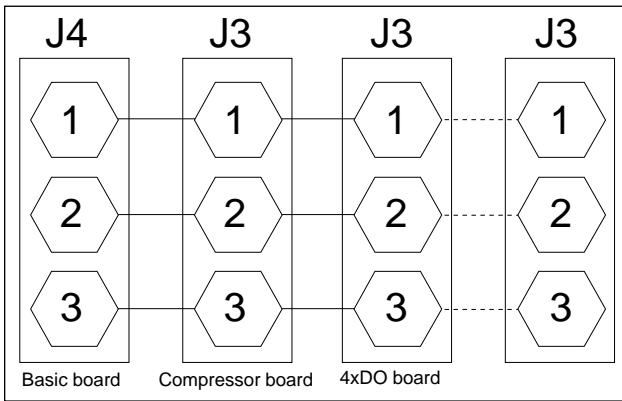

3.2.5 - Slave board addresses

Every slave board (compressor board, 4xDO or 4xAI-2xAO board) has an address which must be set up using the red SIO address switch (marked SIO ADDRESS) at the top righthand corner of each board. This switch consists of 8 DIP switches. The switch is disabled when it is in the OPEN position.

NOTE: Any incorrect address will prevent the unit from starting. Turn off the power before amending the address of any auxiliary board.

Address switch - marked "SIO ADDRESS"

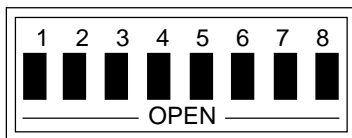

Slave board addresses

BOARD	DIP SWITCH (0 = open)							
	1	2	3	4	5	6	7	8
Compressor board #1	1	0	1	0	0	1	0	1
Compressor board #2	0	0	0	1	0	1	0	1
Compressor board #3	1	1	0	1	0	1	0	1
Compressor board #4	0	1	1	1	0	1	0	1
Compressor board #5	1	0	0	0	1	1	0	1
Compressor board #6	0	0	1	0	1	1	0	1
Compressor board #7	1	1	1	0	1	1	0	1
Compressor board #8	0	1	0	1	1	1	0	1
Board 4xDO #1 EXV circuit A	1	0	1	1	1	1	0	0
Board 4xDO #2 EXV circuit B	1	0	0	0	0	0	1	0
Board 4xDO #3 (fan module)	1	1	1	0	1	0	1	0
Board 4xDO #4 (fan module)	1	1	0	1	1	0	1	0
Board 4xDO #5 (reclaim module)	1	1	1	1	1	0	1	0
Board 4xAI-2xAO #1	1	0	1	0	0	0	1	0
Board 4xAI-2xAO #2	1	1	0	1	0	0	1	0
Board 4xAI-2xAO #3	1	0	0	0	1	0	1	0

3.2.6 - Electrical supply to boards

All boards except analogue boards are supplied from a common 24 V a.c. **floating** supply. Compressor boards also have a 230 V a.c. supply for controlling contactors. Analogue boards have a separate 24 V a.c. supply referred to **earth**.

	Electrical supply to boards			
	Basis board Connector/terminal	Compressorboard Connector/terminal	Board 4xDO Connector/terminal	Board 4xAI-2xAO Connector/terminal
24 V a.c. floating: wires 011-012	J5 / 011-012	J6 / 011-012	J1 / 011-012	-
24 V a.c. referred to earth, wires 11-12	-	-	-	J4 / 011-012*
230 V a.c.	-	J6 / 1-2	-	-
Ground	J5 / 000	-	J1 / 000	J4 / 000

Key

- : no connection
- * : pins 011-012 of connector J4 on the analogue card must be linked to wires 11-12 of the 24 V earthed power supply preserving polarity.

NOTE: When connecting the power supply for the 4xAI-2xAO board, maintain polarity: pins 11 and 12 of the earthed 24 V a.c. supply must be linked to terminals 011 and 012 on the 4xAI-2xAO board, respectively, otherwise the boards may be damaged.

In the event of a power supply interrupt, the unit restarts automatically without the need for an external command. However, any faults active when the supply is interrupted are saved and may in certain cases prevent a circuit or unit from restarting.

3.2.7 - Light emitting diodes on boards

All boards continuously check and indicate the proper operation of their electronic circuits. A light emitting diode (LED) lights on each board when it is operating properly.

MAIN red LED - basic and slave boards

- The MAIN red LED flashes at about 2 second intervals to show that the module is working properly.
- If this LED is permanently unlit, the power supply must be checked.
- On slave boards, if this LED is permanently lit there is a problem requiring the board to be changed.
- On the basic board, if this red LED is permanently lit or flashes in turns strongly then weakly, there is either a faulty basic board or a poorly positioned EPROM.

SIO green LED - basic and slave boards

- This LED flashes continuously to show that the board is communicating correctly over its internal bus.
- If this LED is not flashing, check the wiring of the SIO bus and the address of the board (slave board only). If the basic board is not linked to any slave boards, this LED should not flash.
- If all slave boards indicate a communication fault, check the SIO bus connection on the basic board. If this connection is correct and the fault persists, replace the basic board.

CCN green LED - basic board

- This LED flashes to show that the basic board is communicating over its CCN bus.

3.3 - The controls

3.3.1 - Electronic expansion valve (EXV)

The EXV is used on certain units to adjust the refrigerant flow to changes in the operating conditions of the machine. For this purpose, a series of calibrated orifices are machined into the wall of the refrigerant inlet port. As the refrigerant passes through these orifices, it expands and becomes a bi-phase mixture (liquid and gas).

To adjust the refrigerant flow to changes in operating conditions, a piston moves constantly up or down to vary the cross-section of the refrigerant path. This piston is driven by an electronically controlled linear stepper motor. The high degree of accuracy with which the piston is positioned ensures that the flow of refrigerant is precisely controlled.

NOTE: The external connector of the EXV must be cleaned and coated with silicone grease (Part No. 397 EE) to keep out condensation and prevent corrosion.

3.3.2 - Solenoid valves

Units which do not have EXVs are equipped as necessary with solenoid valves which enable the unit to be pumped down and the high and low pressure sides of the system to be isolated from each other when the system is shut down.

3.3.3 - The head pressure controls

For each circuit, where appropriate, the controller can deal with the following:

- in the case of air-cooled units, fan stages together with, if necessary, a variable speed fan (controlled by an optional 4xAI-2xAO board)
- in the case of water-cooled units, a water valve. This valve is controlled by an optional 4xAI-2xAO board which can deliver a 0-10 V d.c. or 4-20 mA signal, depending on the configuration.

3.3.4 - The evaporator pump

In appropriate cases the controller can also regulate an evaporator pump. This facility does not require an additional board.

3.3.5 - Four-way valves and bypass valves for the heat reclaim option

When the heat reclaim module option is selected, the controller can handle a 4-way valve in respect of each circuit. This valve diverts the refrigerant to the active heat exchanger. It can similarly handle a hot gas bypass valve for emptying the unused exchanger. This option requires an additional 4xDO board.

3.3.6 - Pressure sensors

These are used to measure the following pressures in each circuit:

- Discharge gas pressure
- Suction pressure
- Oil pressure (optional)

These electronic sensors deliver 0 to 5 V d.c. to either the basic board or a 4xAI-2xAO slave board. Two types of sensors are used. One is calibrated for the high pressure side and the other for the low pressure side and oil pressure.

Discharge pressure sensors

These are on the high pressure side of the lead compressor in each circuit. They replace the usual discharge gas pressure gauges and are used as appropriate to control head pressure or by the high pressure load shedding option.

Suction pressure sensors

These are on the low pressure side of the unit, on the lead compressor in each circuit. The outputs from the suction pressure sensors are used to drive the EXVs. They take the place of the low pressure switches, low pressure gauges and oil pressure safety switch (where usually fitted).

Oil pressure sensors - optional

These measure the oil delivery pressure to the compressors at the oil pump outlet ports. The return oil pressure is subtracted from the discharge pressure to arrive at the differential oil pressure.

3.3.7 - Thermistors

These all have similar characteristics.

Evaporator leaving water temperature sensor

This is installed in the evaporator leaving water outlet pipework. The sensor bulb is immersed directly in the leaving water.

Evaporator entering water temperature sensor

This is installed in the evaporator wall in the free space beside the tube bundle.

Compressor suction temperature sensor

These are installed in the lead compressor of each circuit in the suction gas path between the compressor motor and the cylinders above the oil pump. They are only installed on units with EXVs.

Condenser entering and leaving water temperature sensors

These are used to control the heating capacity on heat pumps. They may optionally be fitted to units for cooling only, but in this case have no control function. They are installed in the common condenser entering and leaving line.

Heat reclaim condenser entering/leaving water temperatures

These sensors measure the entering and leaving water temperatures of heat reclaim condensers and are used on air-cooled units fitted with the heat reclaim option. In other cases they may be fitted as options, and in this event are used for information purposes only.

Temperature setpoint reset sensor

This is an optional 0-10 V sensor which can be installed remotely from the unit. It is used to reset the cooling and heating setpoint on the unit as a function of either the outdoor air temperature or ambient room temperature. The sensor is not supplied by Carrier. Its characteristics must be configured by Carrier Service. See section 3.4.10 for connection instructions.

3.4 - Connections at customer's terminal block

The connections below are available at the customer's terminal block. Some of them can only be used in special operating modes. For further details see the sections that describe the functions (section 5) and the configurations (section 4.2.10).

NOTE: The bridge between terminals 32, 63 and 65 on the customer's terminal block must not be removed.

3.4.1 - Fault reporting on circuits A and B

These are volt-free contacts. They must be supplied with 24 V a.c. and maximum current 0.5 A.

Fault report alarm connections

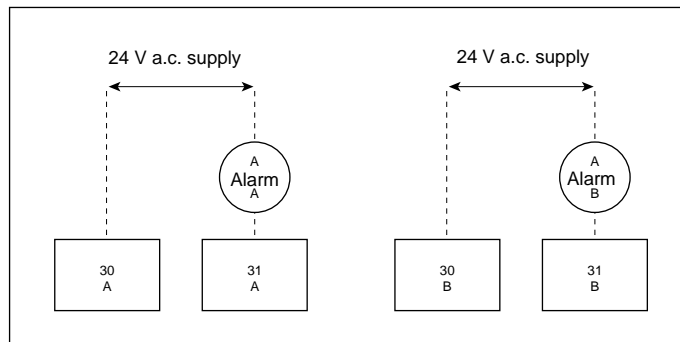

NOTE: To obtain volt-free alarm contact, these outputs must be interfaced with a relay supplied with 24 V a.c. (Carrier Part No. —OK—12AC-034—EE).

NOTE: Connections 30B and 31B are not used on units of the following types:

- Single circuit.
- Water-cooled - 2 compressors - TXV: 30A and 31A fault report alarm common to both circuits.
- Air-cooled - 2 compressors - TXV - 2 fan stages: 30A and 31A fault report alarm common to both circuits.

3.4.2 - Evaporator pump contactor control

The evaporator pump contactor can be supplied with 24 V a.c. and a maximum current of 0.5 A between terminals 12 and 90.

Evaporator pump connections

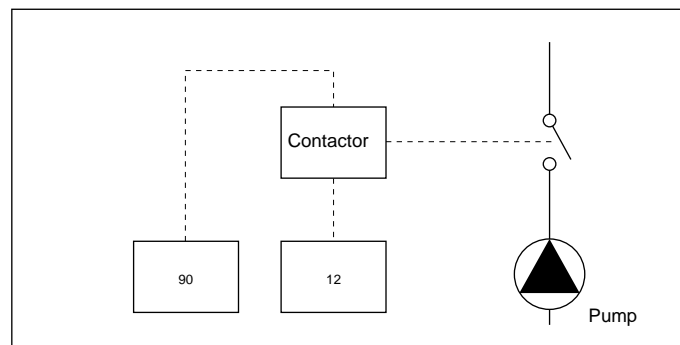

3.4.3 - Remote stop/start volt-free contact

The remote stop/start contact is only taken into account if the unit is in remote control operating type (rEM). See section 4.2.2.

Remote stop/start connections

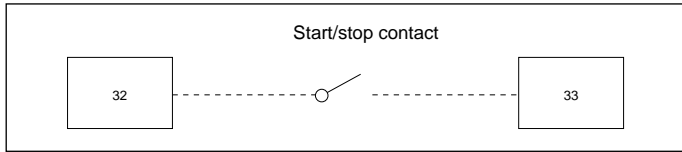

Key:
 Contact open: unit stopped
 Contact closed: start command

NOTE: In exceptional circumstances this contact can be configured as active (configuration by Carrier Service) if the unit operates in CCN mode as part of a master-slave link (see section 5.18).

3.4.4 - Remote volt-free contact for cooling temperature setpoint selection

The remote contact for cooling setpoint selection is only taken into account if the unit is in remote control operating type (rEM). See section 4.2.2.

Connection for remote setpoint selection

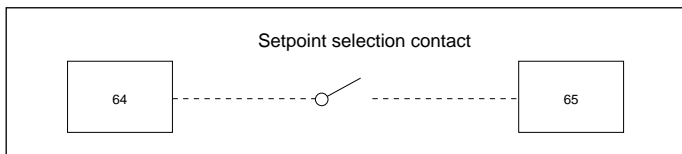

Key:
 Contact open: cooling setpoint 1
 Contact closed: cooling setpoint 2

NOTE: In exceptional circumstances this contact can be configured as active (configuration by Carrier Service) if the unit operates in CCN mode as part of a master-slave link (see section 5.18).

3.4.5 - Remote heat/cool volt-free contact

The remote heat/cool selection contact is only taken into account if the unit is in remote control operating type (rEM). See section 4.2.2.

Connection for remote heat/cool selection

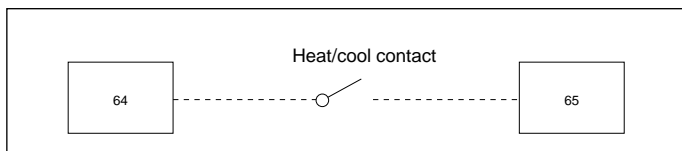

Key
 Contact open: cool
 Contact closed: heat

3.4.6 - Remote heat reclaim volt-free contact

This control is used to select the second condensing setpoint. In addition, it can be used to select heat reclaim mode if the heat reclaim module option is installed. It is only taken into account if the unit is in remote control operating type (rEM). See section 4.2.2.

Connection for heat reclaim mode selection

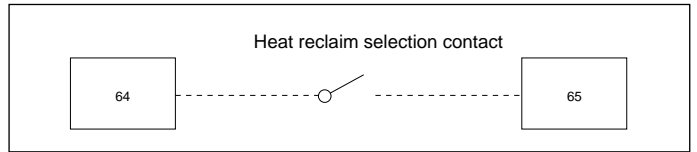

Key:
 Contact open: condensing setpoint 1 / reclaim mode not selected
 Contact closed: condensing setpoint 2 / reclaim mode selected

3.4.7 - Demand limit volt-free contact

This contact is used to activate the demand limit function on the unit (see sections 4.2.10, 4.27 and 5.6). This contact is active whatever the operating type of the unit.

Connection for demand limit contact

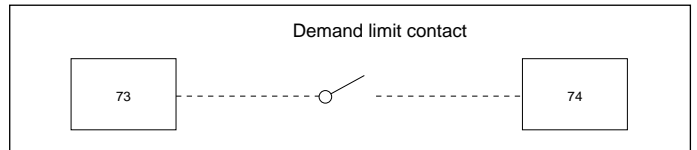

Key:
 Contact open: demand limit disabled
 Contact closed: demand limit active

3.4.8 - Safety lock volt-free contact

If this contact opens, the unit is shut down or prevented from restarting and an alarm is raised. It is generally used to control evaporator water flow.

Safety lock contact connection

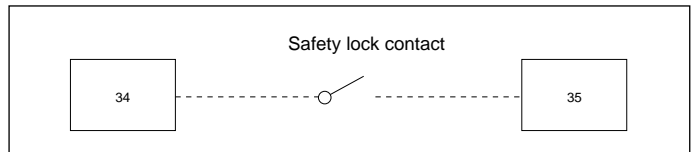

NOTE: When this contact is not used, terminals 34 and 35 must be bridged.

3.4.9 - 0-10 V d.c. input for setpoint reset or demand limit

This 0-10 V d.c. input is used either to reset the setpoint or limit demand on a unit (see configuration, section 4.2.10). This input is active whatever the operating type of the unit. This 0-10 V signal can be delivered by a customer-specific controller or by a 0-10 V temperature sensor.

0-10 Volt signal connection

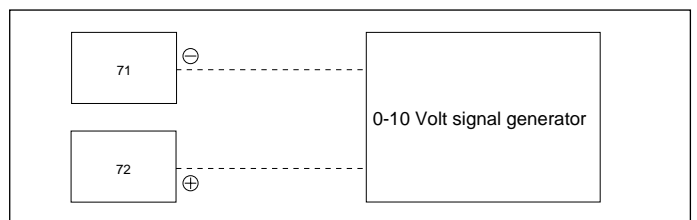

NOTE: Setpoint reset and demand limit based on an external 0-10 V d.c. signal cannot be used at the same time. Reset takes precedence over demand limit.

NOTE: If the source of the 0-10 V d.c. signal is a temperature sensor with a 24 V a.c. supply, it is essential to connect the power supply for this sensor to the earthed 24 V a.c. supply (wires 11-12) and not to the floating 24 V a.c. supply for the basic board.

3.4.11 - Condenser water valve control contacts

These outputs can be used on water-cooled units that have the condenser water valve control option installed. They deliver a 4-20 mA or 0-10 V d.c. signal, depending on the configuration (which must be carried out by Carrier Service).

Water valve connections

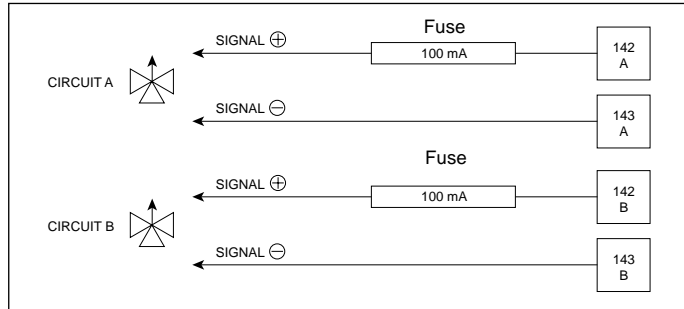

3.4.12 - 24 V a.c. contact

Terminals 11 and 12, located at the end of the customer terminal block, deliver an earthed 24 V a.c. with a maximum 1 A current.

Earthed 24 V a.c. output

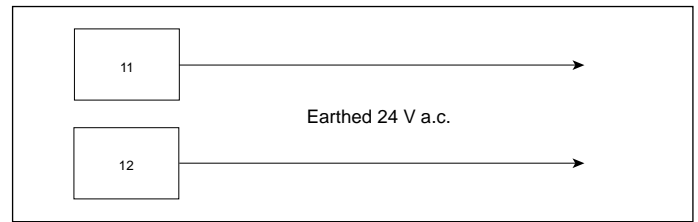

3.4.13 - Connection to the CCN

An RS485 bus is used for connection to the CCN. The CCN connector is located inside the control box on the right hand side of the customer terminal block. It is a three-pin connector:

Pin 1: signal +

Pin 2: ground

Pin 3: signal -

4 - SETTING UP PRO-DIALOG PLUS CONTROL

4.1 - General

The local interface enables a number of operating parameters to be displayed and modified.

The interface consists of two distinct parts:

The main interface (left hand section) gives access to all PRO-DIALOG Plus data and operating functions.

The summary interface (right hand section) gives quick access to just the main PRO-DIALOG Plus operating information.

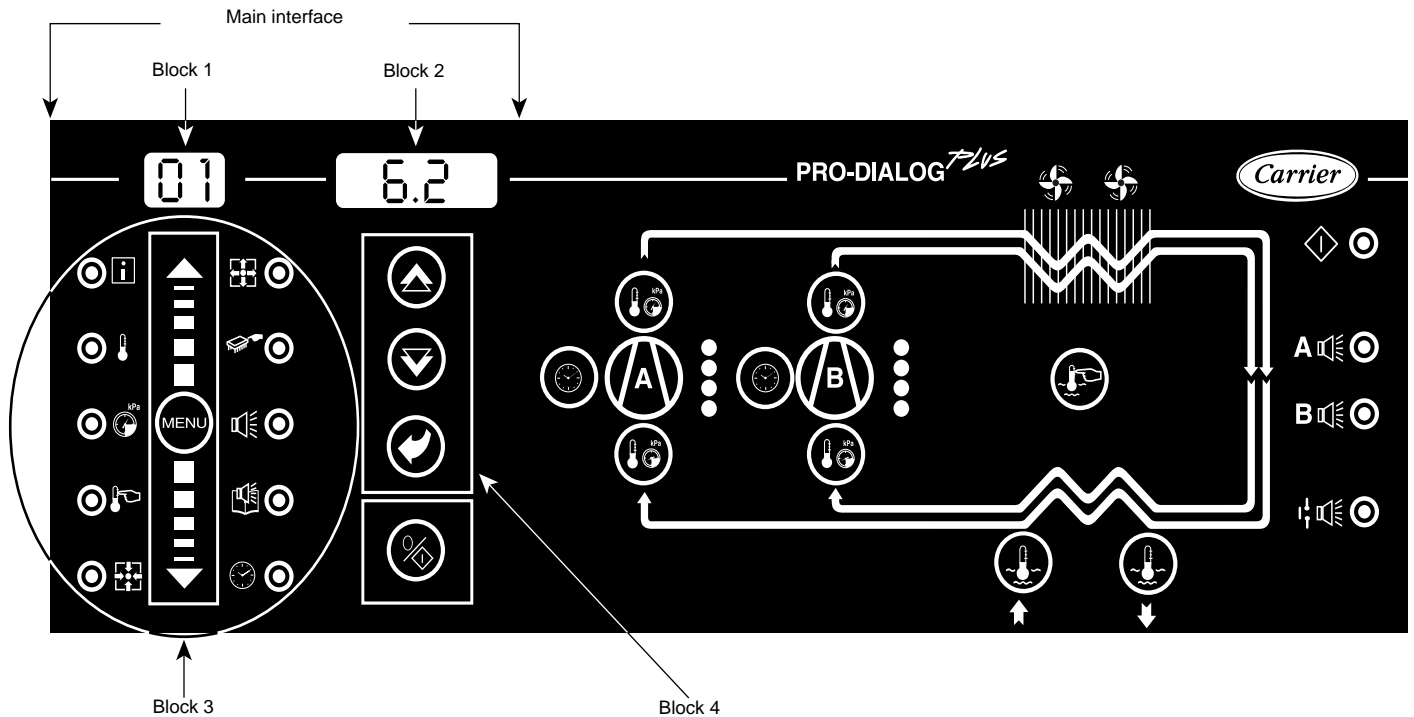

Block 1: A two-digit display showing the number of the item selected.

Block 2: A four-digit display showing the contents of the item selected.

Block 3: Consists of a MENU button, 10 LEDs and 10 icons indicating the menu selected.

Block 4: Consists of three selector buttons \uparrow , \downarrow , \rightarrow . Buttons \uparrow and \downarrow are used to scroll through the numbers of the menu items in block 2, or to increase or decrease the value of any modifiable parameter. The \rightarrow button gives access to the modification mode, or validates a modification.

The \rightarrow button is used to start/stop the chiller and modify its operating type.

4.2 - Main interface

4.2.1 - Description

The main interface gives access to the full array of operating parameters on the unit via 10 menus (represented by 10 icons). Each menu contains up to 20 items (numbered from 0 to 19).

The main interface consists of 4 functional blocks which are described below (the interface shown is for a dual-circuit air-cooled unit):

4.2.2 - Operating types

4.2.2.1 - Description

The start/stop button on the chiller can be controlled by one of the following methods (control type):

- Locally on the actual unit (local control type)
- By remote control with the aid of user contacts (remote control type)
- By remote control with the aid of the CCN (CCN control type).

The main interface includes a \rightarrow button (called the operating type selector button) which can be used to select one of the above control types. In addition, when local control type is selected, this button can be used to select an operating type for the unit (e.g. second setpoint, third setpoint, cool, heat, etc.).

This combination of control types and modes that can be selected using the \rightarrow button is known as the Operating Types.

The Operating Type selector button can also be used locally to halt the unit or to activate one of the following operating types:

OPERATING TYPE	
Block 2 Display	Description
LOFF	Local Off: the unit is halted in local mode.
L-C1	Local operation - Local On - Cooling Setpoint 1: the unit is in local control mode and is authorised to start up in cooling mode with setpoint 1.
L-C2*	Local operation - Local On - Cooling Setpoint 2: the unit is in local control mode and is authorised to start up in cooling mode with setpoint 2. This is displayed if cooling setpoint 1 (item 0 in the setpoint menu) has a different value from cooling setpoint 2 (item 1 in the setpoint menu).
L-H*	Local operation - Local On - Heating Setpoint: the unit is in local control mode and is authorised to start up in heating mode (heat pump only).
LC1r*	Local operation - Local On - Cooling Setpoint 1 - Heat Reclaim: the unit is in local control mode and is authorised to start up in cooling mode with setpoint 1 and the reclaim mode is selected. This is not displayed if one of the following conditions is met: <ul style="list-style-type: none"> the unit is water-cooled and controls condenser water valves, and the condensing setpoint (item 3 in the setpoint menu) is equal to the reclaim setpoint (item 4 in the setpoint menu). the unit is air-cooled and the reclaim option is not selected, and the condensing setpoint (item 3 in the setpoint menu) is equal to the reclaim setpoint (item 4 in the setpoint menu).
LC2r*	Local operation - Local On - Cooling Setpoint 2 - Heat Reclaim: the unit is in local control mode and is authorised to start up in cooling mode with setpoint 2 and the reclaim mode is selected. This is displayed if LC1r is displayed and cooling setpoint 1 (item 0 in the setpoint menu) has a different value from cooling setpoint 2 (item 1 in the setpoint menu).
CCn	The unit is controlled by CCN commands.
rEM	The unit is controlled by external remote control contacts.

Key:
* : Displayed if the configuration requires it.

Section 5.1 gives a more detailed description of the commands to start/stop the unit, analysed by operating type.

4.2.2.2 - Stopping the unit in local mode

The unit can be stopped in local mode at any time by pressing the operating type selector button.

TO STOP THE UNIT			
Button	Action	Block 1 display	Block 2 display
	Press the operating type selector button for less than 4 seconds (one short press is enough)	C	LOFF
	When the button is released, the unit stops without the need for further action.	t	LOFF

4.2.2.3 - Modifying the operating type

The unit operating type can be modified at any time by the following method:

In the example that follows, the operating type to be selected is Local Operation - Cooling Setpoint 1 (L-C1).

CHANGING THE OPERATING TYPE			
Button	Action	Block 1 display	Block 2 display
	Press the operating type selector button for more than 4 seconds	C	LOFF
	Hold down the operating type selector button. The available operating types are displayed one by one until the button is released.		L-C1 L-C2 ↓ ↑ CCn
	Release the operating type selector button when the operating type you want is displayed (in this example L-C1). "C" flashes in block 1 to show that the controller is awaiting confirmation.		L-C1
	Press the button to confirm the operating type selected (in this example L-C1). "t" is displayed in block 1 to indicate the operating type selected. If the button is not pressed soon enough, the controller will cancel the change and continue to use the previous operating type.	t	L-C1

4.2.3 - Displaying/modifying a menu item

To access a menu item, first choose a menu. Each menu gives access to up to 20 items.

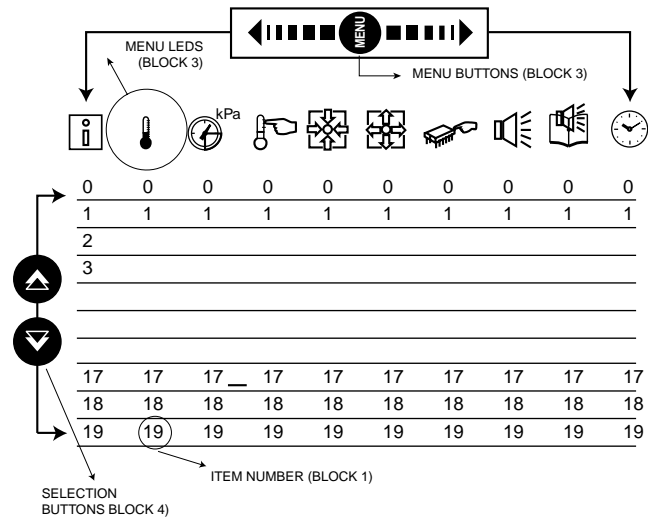

4.2.3.1 - Selecting a menu

The MENU button allows you to select a menu from the 10 that are available. Each time you press this button one of the 10 LEDs lights up in turn alongside each of the icons representing a menu. The active menu is the one against which the LED is lit.

	INFORMATION menu	Displays the general operating parameters for the unit.
	TEMPERATURE menu	Displays the unit operating temperatures.
	PRESSURE menu	Displays the unit operating pressures.
	SETPOINT menu	Displays the unit setpoints and enables them to be modified.
	INPUT menu	Displays the status of the unit digital and analogue inputs
	OUTPUT/TEST menu	Displays the status of the unit outputs and enables them to be tested.
	CONFIGURATION menu	Displays the unit configuration and enables it to be modified.
	ALARM menu	Displays active alarms.
	ALARM HISTORY menu	Displays the history of alarms.
	OPERATING LOG menu	Displays the operating times and number of starts for the unit and its compressors.

NOTE: To scroll quickly through the menus, hold the menu button down.

4.2.3.2 - Selecting a menu item

The and buttons let you scroll through the menu items. Menu item numbers are displayed in block 1. The item number increases or decreases every time you press the or button. The value or status associated with the active item is displayed in block 2.

To scroll quickly through the items, hold the or button down.

NOTE: Menu items that are not in use or incompatible with the configuration are not displayed.

The following example shows how to access item 3 in the Pressure menu.

OPERATION	PRESS BUTTON	BLOCK 3 DISPLAY	BLOCK 1 DISPLAY
Press the MENU button until the LED marked PRESSURE lights.			0
			0
Press one of the arrow buttons until block 1 displays item number 3 (circuit B discharge pressure)			1
			2
			3

4.2.3.3 - Modifying the value of a parameter

Press the button to change to modification mode. This lets you correct the value of an item with the aid of the and buttons (if you are allowed to overwrite the item concerned). When modification mode is activated, the LED for the menu to which the item belongs flashes in block 3. Once the required value is obtained, press the button again to validate the change. The LED for the menu to which the item belongs then stops flashing in block 3, indicating that modification mode no longer applies.

In modification mode, the value to be modified increases or decreases in steps of 0.1 every time you press the or button. Holding one of these buttons down increases the rate of increase or decrease: after 4 seconds each step becomes 0.5, after 10 seconds the step becomes 1.0 and after 15 seconds the step becomes 2.0.

The following example shows how to modify the value of item 2 in the Setpoint menu.

OPERATION	PRESS BUTTON	BLOCK 3 LED	BLOCK 1 DISPLAY	BLOCK 2 DISPLAY
Hold down the MENU button until the LED for SETPOINT lights.			0	
			0	
Press one of the arrow buttons until block 1 displays item number 2 (cooling setpoint 2). The value for setpoint 2 is displayed in block 2 (6.0°C in this example)			1	
			2	6.0
Press the button to enable the value associated with item 2 to be modified. The Setpoint menu LED flashes indicating that modification mode is active.			2	6.0
Keep pressing the button until the value 5.6 is displayed in block 2. The Setpoint menu LED in block 3 keeps flashing.			2	5.9
			2	5.8
			2	5.7
			2	5.6
Press the button again to validate the change. The new setpoint 2 is 5.6°C. The Setpoint menu LED in block 3 stops flashing, indicating that modification mode no longer applies.			2	5.6



ITEM	INFORMATION	TEMPERATURES	PRESSURES	SETPOINTS	INPUTS	OUTPUTS	CONFIGURATIONS	ALARMS	ALARMS HIST.	OPERATING LOG
0	Operating type	Evaporator water entering temperature	Circuit A discharge pressure	Cooling setpoint 1	Remote start/stop contact status	Circuit A compressor status*	Password	Number of active alarms/ resets	Historic alarm code 1**	Unit operating hours/10
1	Mode	Evaporator water leaving temperature	Circuit A suction pressure	Cooling setpoint 2	Remote setpoint contact status	Circuit B compressor status*	Head pressure control method*	Active alarm code 1**	Historic alarm code 2**	Circuit A operating hours/10
2	Mode*	Copndenser water entering temperature*	Oil pressure differential compressor A1*	Heating setpoint*	Remote heat/cool contact status*	A & B unloader status*	Lead/lag select*	Active alarm code 2**	Historic alarm code 3**	Compressor A2 operating hours/10*
3	Mode*	Condenser water leaving temperature*	Circuit B discharge pressure*	Condensing setpoint*	Remote reclaim operat. contact status*	Status - fans A1 & A2, A3 & A4*	Circuit loading sequence*	Active alarm code 3**	Historic alarm code 4**	Compressor A3 operating hours/10*
4	Mode*	Reclaim water entering temperature*	Circuit B suction pressure*	Reclaim setpoint*	Stage reduction contact status*	Status - Fans B1 & B2, B3 & B4*	Delay at start-up	Active alarm code 4**	Historic alarm code 5**	Compressor A4 operating hours/10*
5	Mode*	Reclaim water leaving temperature*	Oil differential pressure compressor B1*	Capacity reduction setpoint as %	Safety lock ckecking contacts status	Alarm status circuit A & circuit B	Ramp loading selection	Active alarm code 5**	Historic alarm code 6**	Circuit B operating hours/10*
6	Cooling/heating*	Saturated discharge temp. circuit A	Oil differential pressure compressor A2*	Cooling loading rate ramp	External 0-10 V d.c. signal	Valve status Solenoids A & B*	Setpoint reset selection	-	Historic alarm code 7**	Compressor B2 operating hours/10*
7	Number of capacity stages	Saturated suction temp. circuit A	Oil differential pressure compressor A3*	Heating loading rate ramp*	-	Position of of EXV A in %*	Demand limit selection	-	Historic alarm code 8**	Compressor B3 operating hours/10*
8	Present demand limit in %	Suction temperature. compressor A1	Oil differential pressure compressor A4*	Cooling - 0-10 V d.c. signal for zero reset*	-	Position of of EXV B in %*	Software version number	-	Historic alarm code 9**	Compressor B4 operating hours/10*
9	Unit capacity in %	Superheat circuit A*	Oil differential pressure compressor B2*	Cooling - 0-10 V d.c. signal for full reset*	-	Fan speed/ valve position circuit A in %*	ENO	-	Historic alarm code 10**	Number of unit start-ups/10
10	Capacity circuit A in %	Saturated discharge temp. circuit B*	Oil differential pressure compressor B3*	Cooling - delta temperature for zero reset*	-	Fan speed/ valve position circuit B in %*	BUS	-	-	Number of circuit A start-ups/10
11	Capacity circuit B in %*	Saturated suction temp. circuit B*	Oil differential pressure compressor B4*	Cooling - delta temperature for full reset*	-	4-way reclaim valve status circuits A & B*	-	-	-	Number of compressor A2 start-ups/10*
12	Active setpoint	Suction temperature compressor B 1*	-	Cooling - full reset degrees value*	-	Reclaim hot gas bypass status circuits A & B*	-	-	-	Number of compressor A3 start-ups/10*
13	Control point	Superheat circuit B*	-	Heating - 0-10 V d.c. signal for zero reset*	-	Evaporator water pump status	-	-	-	Number of compressor A4 start-ups/10*
14	Active condensing setpoint*	Outdoor temperature*	-	Heating - 0-10 V d.c. signal for full reset*	-	Local test interface	-	-	-	Number of compressor B start-ups/10*
15	Overrides	-	-	Heating - delta temperature for zero reset*	-	-	-	-	-	Number of compressor B2 start-ups/10*
16	SMZ	-	-	Heating - delta temperature for full reset*	-	-	-	-	-	Number of compressor B3 start-ups/10*
17	ZM	-	-	Heating - full reset degrees value*	-	-	-	-	-	Number of compressor B4 start-ups/10*

Key:

* Displayed if the configuration requires it.

** Displayed if the alarm exists.

- Not in use.

4.2.4 - Description of the INFORMATION menu

This menu is used to display the unit's main operating parameters.



ITEM	FORMAT	DESCRIPTION
0		Displays active operating type
	LOFF	Local Off
	L-C1	Local On - Cooling setpoint 1
	L-C2	Local On - Cooling setpoint 2
	L-H	Local On - heating setpoint
	LC1r	Local On - Cooling setpoint 1 - Reclaim
	LC2r	Local On - Cooling setpoint 2 - Reclaim
	CCn	CCN Control
	rEn	Remote Control
1	n ₁ n ₂ n ₃ n ₄	Displays active modes: n ₁ n ₂ = 1st active mode n ₃ n ₄ = 2nd active mode
2***	n ₁ n ₂ n ₃ n ₄	Displays active modes: n ₁ n ₂ = 3rd active mode n ₃ n ₄ = 4th active mode
3***	n ₁ n ₂ n ₃ n ₄	Displays active modes: n ₁ n ₂ = 5th active mode n ₃ n ₄ = 6th active mode
4***	n ₁ n ₂ n ₃ n ₄	Displays active modes: n ₁ n ₂ = 7th active mode n ₃ n ₄ = 8th active mode
5***	n ₁ n ₂ n ₃ n ₄	Displays active modes: n ₁ n ₂ = 9th active mode n ₃ n ₄ = 10th active mode
6**	Cool Heat	Heating/cooling operation Cool/heat
7	nn	Number of active capacity stages
8**	nnn Inh	Present demand limit in % Demand limit disabled in Local operating type
9	nnn	Total active capacity of unit in %
10	nnn	Total active capacity of circuit A in %
11*	nnn	Total active capacity of circuit B in %
12	±nn.n	Active setpoint in °C
13**	±nnn	Control point in °C
14**	nn.n	Condensing or reclaim setpoint in °C
15	n ₁ n ₂ n ₃ n ₄	Reserved for use by Carrier Service only
16	±nnn	Reserved for use by Carrier Service only
17	n.n	Reserved for use by Carrier Service only

Key:

n : numerical display

* : This item is displayed in certain unit configurations only.

** : Under certain operating conditions this item flashes (in block 1 of main interface).

*** : This item is not displayed when zero.

Item 0 Displays active operating type

This item displays the current operating type in text format.

Items 1-2-3-4-5 Displays active modes

Each of these items can display two active modes at the same time. The first two figures display one mode and the last two figures display another. These items enable up to 10 active modes to be displayed.

For example: 510 means that modes 5 and 10 are active. 11 means that mode 11 is active.

Description of modes:

MODE#	MODE NAME	DESCRIPTION
1	Local Off	The unit has stopped in local mode because operating type Local Off (LOFF) has been selected with the operating type selector button.
2	CCN Off	The unit has stopped in CCN mode because operating type CCN (CCn) has been selected with the operating type selector button and either: <ul style="list-style-type: none"> the unit has received a CCN halt command, or the controller has received a start command over the network but the start/stop remote control is authorised in CCN mode and the controller has received a halt command from a volt-free contact connected to the customer terminal block (see note, section 5.1).
3	Remote off	The unit has stopped in remote mode because operating type Remote Control (rEM) has been selected with the operating type selector button and the unit has received a shutdown command from volt-free contacts. See section 3.4.3, description of start/stop contact.
4	Local Operation	The unit is authorised to start up in local mode because operating mode Local Operation (L-C1 or L-C2 or L-H or LC1r or LC2r) has been selected with the operating type selector button.
5	CCN Operation	The unit is authorised to start up in CCN mode because operating type CCN (CCn) has been selected with the operating type selector button and the unit has received a CCN start command, and either: <ul style="list-style-type: none"> the start/stop remote control is not authorised in CCN mode, or the start/stop remote control is authorised in CCN mode and the controller has received a start command from a volt-free contact connected to the customer terminal block (see note, section 5.1).
6	Remote Operation	The unit is authorised to start up in remote mode because operating type Remote Control (rEM) has been selected with the operating type selector button and the unit has received a start command from volt-free contacts. See section 3.4.3, description of start/stop contact.
7	Delay at start-up active	The delay at start-up is active after the unit has been switched on or after the unit has been stopped. If the pause has not expired the mode is active. The delay can be configured in the configuration menu.
8	2nd cooling setpoint active	The second cooling setpoint is active because one of the following conditions has been met: <ul style="list-style-type: none"> Operating type Local Operation - Cooling Setpoint 2 (L-C2) has been selected; The unit is in operating type CCN (CCn) and has received a network command to use cooling setpoint 2; The unit is in operating type Remote (rEM) and cooling setpoint 2 has been selected with remote contacts. See section 3.4.4, description of setpoint selection contact.
9	Setpoint reset active	Setpoint reset is active. In this mode, the unit uses the reset function to adjust the leaving water temperature setpoint. Depending on the configuration, the setpoint can be reset by reference to: <ul style="list-style-type: none"> An external 0-10 V d.c. signal (supplied by customer or 0-10 V d.c. temperature sensor); The difference in temperature between water leaving and returning to the evaporator (cooling) or condenser (heating); For the reset function to be activated it must be configured (see section 4.2.10). Mode 9 is only active if the reset value calculated by the system is non-zero.
10	Demand limit active	Demand limit is active. In this mode, the demand at which the unit is authorised to operate is limited by reference to either: <ul style="list-style-type: none"> An external 0-10 V d.c. signal (supplied by customer) or A volt-free contact. For the demand limit function to be activated it must be configured (see section 4.2.10). Mode 10 is only active if the machine demands capacity greater than the limit value.
11	Ramp loading active	Ramp loading is active. In this mode, the rate of temperature drop (cooling mode) or rise (heating mode) in °C/minute in the active heat exchanger leaving water is limited to a preset value in order to prevent compressor overload. The ramp values can be modified (see section 4.2.7).
12	Reclaim selected	The unit is authorised to go to reclaim mode and use the second condensing setpoint (reclaim setpoint) because: <ul style="list-style-type: none"> Operating type Local Operation - Cooling Setpoint 1 or 2 - Reclaim Mode has been selected (LC1r or LC2r), or The unit is in operating type CCN (CCn) and has received a network command authorising reclaim operation, or The unit is in operating type Remote (rEM) and the volt-free contact authorising reclaim mode is closed. See the description of the reclaim remote contact in section 3.4.6.
13	Reclaim mode active	Reclaim mode is active because mode 12 is active and the temperature of the leaving reclaim water is lower than the reclaim setpoint. This mode only applies to air-cooled units fitted with the optional reclaim module.
14	Low suction temperature protection	Protection for evaporator suction low temperature circuit is active. In this mode, circuit capacity is not authorised to rise if the unit is in cooling mode, and saturated suction temperature in the circuit is 13°C or more lower than the leaving chilled water temperature, and is lower than the frost protection threshold minus 1.1°C.
15	Low temperature protection heating mode	The unit is in heating mode and the temperature of the evaporator leaving water is lower than the lesser of the two cooling setpoints. A capacity stage is removed. This mode only applies to heat pumps.
16	Low superheat protection	When low superheat conditions have been satisfied the circuit stops with pumping down and is authorised to restart. During the stop/restart sequence, mode 16 is activated. See description of alarms 48 and 49. This mode only applies to units fitted with EXVs.

MODE#	MODE NAME	DESCRIPTION
17	High pressure protection circuit A	Circuit A is under high pressure protection because the HP protection threshold has been exceeded. Circuit capacity is not authorised to rise, and any slave compressors may be stopped in order to prevent a high pressure break. This mode only applies if the high pressure load shedding option has been validated.
18	High pressure protection circuit B	Circuit B is under high pressure protection because the HP protection threshold has been exceeded. Circuit capacity is not authorised to rise, and any slave compressors may be stopped in order to prevent a high pressure break. This mode only applies if the high pressure load shedding option has been validated.
19	Unit under SM control	Unit is under control of a System Manager (FSM or CSM III)
20	Master/slave link active	Unit is connected to a secondary unit by a master/slave link and either: <ul style="list-style-type: none"> The unit is configured as a master and this master is operating, or The unit is configured as a slave and the master is operating.

OPERATION	PRESS BUTTON	BLOCK 3 LED	BLOCK 1 DISPLAY	BLOCK 2 DISPLAY
Hold down the MENU button until the LED for INFORMATION lights.			0	
Press one of the arrow buttons until block 1 displays item number 6 (demand limit). The active demand limit value is displayed in block 2 (75% in this example).			1	
Press the button. The INFORMATION menu LED flashes indicating that modification mode is active.			6	75
Press the or button. "InH" is displayed in block 2. The INFORMATION menu LED in block 3 keeps flashing.			6	InH
Press the button again. Demand limit is now disabled. The INFORMATION menu LED stops flashing.			6	InH

Item 6 Heating/cooling operation

This information is only available on units configured as heat pumps. This item shows the current operating mode.

The cooling mode is active in the following cases:

- The unit is in operating type Local Cooling (L-C1 or LC2).
- The unit is in operating type CCN (CCn) and has received a cooling operation network command.
- The unit is in operating type Remote (rEM) and has received a cooling operation command from a remote contact (see section 3.4.5, description of remote heat/cool contact).

The heating mode is active in the following cases:

- The unit is in operating type Local Heating (L-H).
- The unit is in operating type CCN (CCn) and has received a heating operation network command.
- The unit is in operating type Remote (rEM) and has received a heating operation command from a remote contact (see section 3.4.5, description of remote heat/cool contact).

Item 7 Number of active capacity stages
This is the number of capacity stages operating.

Item 8 Demand limit active
This is the authorised operating capacity of the unit. The value depends on the limitation method used (see section 4.2.10):

- based on an external 0-10 V d.c. signal;
- based on the limit setpoint and the status of a remote contact.

Disabling of demand limit in local mode: when the unit is in **local** operating mode it is possible to disable demand limit from any source, via the keyboard. For this purpose, follow the procedure described below.

The procedure for cancelling demand limit disablement in local mode is exactly as described above. When the setpoint LED flashes, press the procedure for cancelling demand limit disablement in local mode is exactly as described above. When the setpoint LED flashes, press the or button. This cancels the "InH" display and restores reduction. Then press the button.

Item 9 Total active capacity of unit as %
This is the percentage of compressor capacity used by the unit.

Item 10-11 Total active capacity of circuits A/B as %
This is the percentage of compressor capacity used on circuits A/B.

Item 12 **Active setpoint**
This is the current heating or cooling setpoint.

It refers to cooling setpoint 1 in the following cases:

- The unit is in operating type Local Operation - Cooling Setpoint 1 (L-C1 or LC1r).
- The unit is in operating type CCN (CCn) and cooling mode, and has received a network command to use setpoint 1.
- The unit is in operating type Remote (rEM) and has received a command to operate in cooling type and to use setpoint 1, from a remote contact (see section 3.4.4, description of remote cooling setpoint selection contact).

It refers to cooling setpoint 2 in the following cases:

- The unit is in operating type Local Operation - Cooling Setpoint 2 (L-C2 or LC2r).
- The unit is in operating type CCN (CCn) and cooling mode, and has received a network command to use setpoint 2.
- The unit is in operating type Remote (rEM) and has received a command to operate in cooling mode and to use setpoint 2, from a remote contact (see section 3.4.4, description of remote cooling setpoint selection contact).

Cooling setpoint 2 is normally used for ice storage.

It refers to heating setpoint in the following cases:

- The unit is in operating type Local Operation - Heating Setpoint (L-H).
- The unit is in operating type CCN (CCn) and heating mode.
- The unit is in operating type Remote (rEM) and has received a command to operate in heating mode.

NOTE: The setpoint selection contact may in exceptional cases be configured as active (configuration by Carrier Service) if the unit operates in CCN mode as part of a master-slave link (see section 5.18).

- The unit is in operating type Remote (rEM) and has received a command to operate in cooling mode and normal condensing type (no reclaim), from a remote contact (see section 3.4.6, description of remote contact).

It refers to the reclaim setpoint in the following cases:

- The unit is in operating type Local - Cooling Setpoint 1 (LC1r or LC2r).
- The unit is in operating type CCN (CCn) and cooling mode, and is under network command for reclaim mode.
- The unit is in operating type Remote (rEM) and has received a command to operate in cooling mode and reclaim condensing mode, from a remote contact (see section 3.4.6, description of remote contact).

The number for item 14 flashes (in block 1 of the user interface) when the unit is in CCN operating mode and the condensation value is forced by the CCN.

Item 13

Control point

This is the setpoint used by the controller to adjust the temperature of leaving water. Control point = active setpoint + reset. The reset is generally positive in cooling mode and negative in heating mode. See section 4.2.7, calculating the reset.

Item number 11 flashes (in block 1 of the user interface) when the unit is in CCN operating type and the control point is forced by the CCN.

Item 14

Condensing setpoint

This is the setpoint used by the controller to adjust the condensing or reclaim temperature.

It refers to the normal condensing setpoint in the following cases:

- The unit is in operating type Local Operation - Cooling Setpoint 1 (L-C1 or LC2).
- The unit is in operating type CCN (CCn) and cooling mode, and is under network command for normal mode (no reclaim).

Items 15-16-17 Reserved for use by Carrier Service only

4.2.5 - Description of the TEMPERATURES menu

This menu displays the unit operating temperatures. All temperatures are displayed in degrees Celsius. Access to this menu is read-only.



ITEM	FORMAT	DESCRIPTION
0	±nn.n	Evaporator entering water temperature
1	±nn.n	Evaporator leaving water temperature
2*	±nn.n	Condenser entering water temperature (if used)
3*	±nn.n	Condenser leaving water temperature (if used)
4*	±nn.n	Reclaim condenser entering water temperature (if used)
5*	±nn.n	Reclaim condenser leaving water temperature (if used)
6	±nn.n	Saturated condensing temperature circuit A
7	±nn.n	Saturated suction temperature circuit A
8*	±nn.n	Suction temperature compressor A1
9*	±nn.n	Superheat temperature circuit A
10*	±nn.n	Saturated condensing temperature circuit B
11*	±nn.n	Saturated suction temperature circuit B
12*	±nn.n	Suction temperature compressor B1
13*	±nn.n	Superheat temperature circuit B
14*	±nn.n	Outdoor temperature

Key:

n : numerical display

* : This item is displayed in certain unit configurations only.

Item 14

Outdoor temperature

This item displays the outdoor temperature if an outdoor temperature sensor is connected to the 0-10 V d.c. analogue input on the customer terminal block and if that sensor has been calibrated (by Carrier Service). If it has not been calibrated, the value displayed is the value of the incoming 0-10 V d.c. signal.

4.2.6 - Description of the PRESSURE menu

This menu displays the unit operating pressures. All pressures are relative, and are expressed in kPa. Access to this menu is read-only.



ITEM	FORMAT	DESCRIPTION
0	nnnn	Discharge pressure circuit A
1	nnnn	Suction pressure circuit A
2*	±nnn	Differential oil pressure compressor A1
3*	nnnn	Discharge pressure circuit B
4*	nnnn	Suction pressure circuit B
5*	±nnn	Differential oil pressure compressor B1
6*	±nnn	Differential oil pressure compressor A2
7*	±nnn	Differential oil pressure compressor A3
8*	±nnn	Differential oil pressure compressor A4
9*	±nnn	Differential oil pressure compressor B2
10*	±nnn	Differential oil pressure compressor B3
11*	±nnn	Differential oil pressure compressor B4

Key:

n : numerical display

* : This item is displayed in certain unit configurations only.

4.2.7 - SETPOINT menu

This menu displays the unit setpoints. These points can be modified when the unit is in Local operating mode.



ITEM	FORMAT	DESCRIPTION
0	±nn.n	Cooling setpoint 1 in °C
1	±nn.n	Cooling setpoint 2 in °C
2*	nn.n	Heating setpoint in °C. Heat pump only.
3*	nn.n	Condensing setpoint 1 in °C.
4*	nn.n	Condensing or reclaim setpoint 2 in °C.
5	nnn	Demand limit as %
6*	n.n	Cooling mode ramp in °C/minute
7*	n.n	Heating mode ramp in °C/minute. Heat pump only.
8*	nn.n	Voltage reset 0-10 V d.c. cooling mode - Voltage for zero reset
9*	nn.n	Voltage reset 0-10 V d.c. cooling mode - Voltage for max. reset
10*	±nn.n	Delta T reset cooling - Delta T for zero reset
11*	±nn.n	Delta T reset cooling - Delta T for maximum reset
12*	±nn.n	Cooling reset - Maximum reset value in °C
13*	nn.n	Voltage reset 0-10 V d.c. heating mode - Voltage for zero reset
14*	nn.n	Voltage reset 0-10 V d.c. heating mode - Voltage for max. reset
15*	±nn.n	Delta T reset heating - Delta T for zero reset
16*	±nn.n	Delta T reset heating - Delta T for maximum reset
17*	±nn.n	Heating reset - Maximum reset value in °C

Key:

n : numerical display

* : This item is displayed in certain unit configurations only.

Items 0-1

Cooling setpoint 1 & 2

This item lets you display and modify the cooling setpoints. Cooling setpoint 2 is generally used for ice storage.

See section 4.2.4, description of item 10 (active setpoint) and the conditions of use for setpoints 1 and 2.

Item 2

Heating setpoint

This item is used for heat pumps only. It can be used to display and modify the heating setpoint.

See section 4.2.4, description of item 10 (active setpoint) and the conditions of use for the heating setpoint.

Limiting values for the cooling and heating setpoints

SET POINT	R-22		R-134 a		R-407c	
	°F	°C	°F	°C	°F	°C
Minimum cooling value						
• Water & multitube evaporator	38	3,3	38	3,3	41	8
• Water and plate evaporator	42	5,5	42	5,5	42	5,5
• Medium Brine	14	-10	14	-10	14	-10
• Low Brine	-20	-28,8	-13	-25	5	-15
Maximum cooling value	86	38,3	86	38,3	86	38,3
Maximum heating value	133	56,1	138	58,8	120	48,8
Minimum heating value	80	26,6	80	26,6	80	26,6

Item 3

Condensing setpoint

This item is used to display and modify the condensing setpoint. It is used by the system to control the fan stages or a variable speed fan (air-cooled unit) or to control condenser water valves (water-cooled unit) when the unit is not in reclaim mode (see section 4.2.4, item 14, the conditions of use for the normal condensing setpoint).

Item 4

Reclaim setpoint

This item is used to display and modify the reclaim setpoint. As in item 3, it is used to control condensation and, in addition, controls toggling between reclaim and non-reclaim modes when the optional reclaim module is used (see section 4.2.4, item 14, the conditions of use for the reclaim setpoint).

Limiting values for the condensing setpoints

CONDENSING SETPOINT	R-22		R-134 a		R-407c	
	°F (psig)	°C (kPa)	°F (psig)	°C (kPa)	°F (psig)	°C (kPa)
Minimum temperature (corresponding pressure)	80 (144)	26,6 (992)	80 (86)	26,6 (593)	80 (142)	26,6 (980)
Maximum temperature (corresponding pressure)	135 (320)	57,2 (2206)	140 (226)	60 (1558)	122 (270)	50 (1860)

Item 5

Demand limit setpoint

This item is used to define the maximum capacity that the unit is authorised to put into operation when the demand limit contact is closed and if reduction by contact has been selected (see section 3.4.7, description of contact, and section 4.2.10, configuring the demand limit method).

Range: 0 to 100 %

Items 6-7 Cooling/heating mode ramp
 These items refer to the rates of temperature drop (cooling mode) or temperature rise (heating mode) in °C/minute in the active heat exchanger leaving water. These parameters are only accessible if the ramp function is validated in the configuration menu (see section 4.2.10). When the capacity loading of the unit is effectively limited by the ramp, mode 11 is displayed in the information menu (see section 4.2.4).

Range: 0.1 to 1.1°C/min

Items 8 to 17 Setpoint reset
 In normal operating conditions, the unit maintains a leaving water temperature at the heat exchanger (i.e. evaporator in cooling mode or condenser in heating mode) which is more or less equal to the active cooling or heating setpoint. This setpoint is generally chosen by reference to full load operating conditions. Under partial load, it may be necessary to reset the setpoint upwards (in cooling mode) or downwards (in heating mode) in order to optimise the unit performance.

The system uses the control point to adjust the water leaving temperature:

- Control point = active setpoint + reset (cooling mode)
- Control point = active setpoint - reset (heating mode)

When the reset function is active (i.e. when the calculated reset value is non-zero) mode 9 is displayed (see section 4.2.4).

Items 8-9-12 Voltage reset - Cooling mode values
 Items 13-14-17 Voltage reset - Heating mode values

This function is only active when reset based on an external 0-10 V d.c. signal has been selected (see section 4.2.10).

Voltage reset is based on an external 0-10 V d.c. signal applied to specific inputs on the customer terminal block (see section 3.4.10). The source of this signal is usually a 0-10 V d.c. external ambient or air temperature probe which gives a measure of the load trends for the building. If this is the case, the reset parameters are generally configured to deliver the following:

- In cooling mode, an reset with a negative slope. The controller automatically resets the chilled water setpoint upwards in response to a drop in the outside or ambient temperature.
- In heating mode, an reset with a positive slope. The controller automatically resets the chilled water setpoint downwards in response to a rise in the outside or ambient temperature.

However, the reset parameters remain accessible to any type of configuration and make it possible to obtain any combination of slope and reset origin in response to the 0-10 V d.c. input signal.

Voltage reset is a linear function which requires three parameters to be configured:

- A 0-10 V d.c. reference value at which the reset is zero: this is the “*voltage for zero reset*” (item 8 for cooling mode - item 13 for heating mode).
- A 0-10 V d.c. reference value at which the reset is at maximum: this is the “*voltage for maximum reset*” (item 9 for cooling mode - item 14 for heating mode).
- The maximum reset value: this is the “*maximum reset value*” (item 12 for cooling mode - item 17 for heating mode).

Range: Voltage for zero reset:
0 to 10 volts

Voltage for maximum reset:
0 to 10 volts

Maximum reset value:
-16.6 to 16.6°C

The reset is calculated as follows if the value of the “*Voltage for zero reset*” exceeds the value of the “*Voltage for maximum reset*”:

- The reset is zero if the external 0-10 V d.c. reset signal exceeds the reference value “*Voltage for zero reset*”.
- The reset equals the maximum reset value if the external 0-10 V d.c. reset signal is lower than the reference value “*Voltage for maximum reset*”.
- If the 0-10 V d.c. reset signal is between the reference values “*Voltage for zero reset*” and “*Voltage for maximum reset*”, the reset value is calculated by linear interpolation between the “*Maximum reset*” value and 0.

The reset is calculated as follows if the value of the “*Voltage for zero reset*” is lower than the value of the “*Voltage for maximum reset*”:

- The reset is zero if the external 0-10 V d.c. reset signal is lower than the reference value “*Voltage for zero reset*”.
- The reset equals the “*Maximum reset value*” if the external 0-10 V d.c. reset signal exceeds the reference value “*Voltage for maximum reset*”.
- If the 0-10 V d.c. reset signal is between the reference values “*Voltage for zero reset*” and “*Voltage for maximum reset*”, the reset value is calculated by linear interpolation between 0 and the “*Maximum reset*” value.

Sample voltage reset configuration:

In this example, the cooling setpoint starts to be reset with effect from 6.6 V d.c. (full load) up to a maximum reset of 3°C at 5.0 V d.c. This example assumes that the:

- Voltage reset has already been configured in the configuration menu (see section 4.2.10, configuration).

The configuration shall be as follows:

- Zero reset if the external signal (“Voltage for zero reset” - Item 8) is greater than 6.6 volts;
- Maximum reset 3°C (Maximum reset value - Item 12) if the external signal (“Voltage for maximum reset” - Item 9) is lower than 5.0 volts.

OPERATION	PRESS KEY	BLOCK 3 LED	BLOCK 1 DISPLAY	BLOCK 2 DISPLAY
Press the button again to validate the change. The new value for item 9 is 5.6 volts. The SETPOINT menu LED stops flashing, indicating that modification mode no longer applies.			9	5.0
Press until block 1 displays item number 12; this item shows the maximum reset value in cooling mode. The default value (0°C) is displayed in block 2.			9	5.0
			12	0.0
Press the button to authorise modification of the value associated with item 12. The SETPOINT menu LED flashes indicating that modification mode is active and the value can be modified.			12	0.0
Press until the value 3.0 is displayed in block 2. The SETPOINT menu LED in block 3 keeps flashing.			12	0.1
			12	3.0
Press the button again to validate the change. The new value for item 12 is 3.0°C. The SETPOINT menu LED stops flashing, indicating that modification mode no longer applies.			12	3.0

Let us assume that the 0-10 V d.c signal comes from a calibrated outside temperature probe (configuration accessible to Carrier Service only) with the following parameters:

- The probe delivers 0 volts at -20°C.
 - The probe delivers 10 volts at 40°C.
- Based on this information:
- The probe delivers 5.0 volts at 10°C.
 - The probe delivers 6.6 volts at 20°C.

The active cooling setpoint reset curve is then as follows:

Cooling setpoint voltage reset

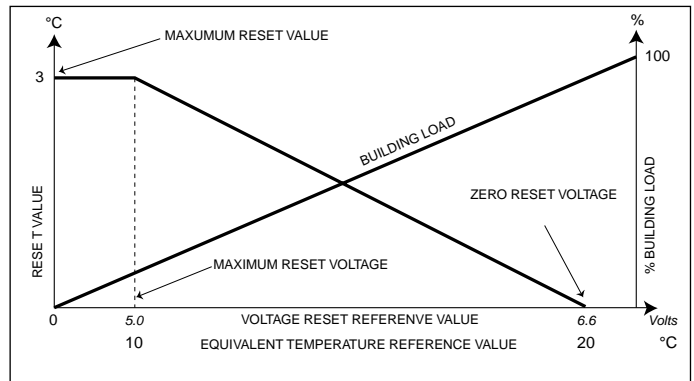

- Items 10-11-12 ΔT reset - Cooling mode reset values
- Items 15-16-17 ΔT reset - Heating mode reset values

This function is only active if a reset based on water returning to the evaporator (cooling mode) or condenser (heating mode) has been selected (see section 4.2.10). In the following description, ‘ ΔT ’ represents the temperature difference between water entering and leaving the evaporator in cooling mode or the condenser in heating mode.

OPERATION	PRESS KEY	BLOCK 3 LED	BLOCK 1 DISPLAY	BLOCK 2 DISPLAY
Hold down the MENU button until the LED for SETPOINT lights.			0	
			0	
Press or until block 1 displays item number 8; this item shows the zero reset voltage in cooling mode. The default value (0 volts) is displayed in block 2.			0	1
			8	0.0
Press the button to authorise modification of the value associated with item 8. The SETPOINT menu LED flashes indicating that modification mode is active and the value can be modified.			8	0.0
Press the until the value 6.6 is displayed in block 2. The SETPOINT menu LED in block 3 keeps flashing.			8	0.1
			8	6.6
Press the button again to validate the change. The new value for item 8 is 6.6 volts. The SETPOINT menu LED stops flashing, indicating that modification mode no longer applies.			8	6.6
Press until block 1 displays item number 9; this item shows the maximum reset voltage in cooling mode. The default value (0 volts) is displayed in block 2.			9	0.0
Press the button to authorise modification of the value associated with item 9. The SETPOINT menu LED flashes indicating that modification mode is active and the value can be modified.			9	0.0
Press until the value 5.0 is displayed in block 2. The SETPOINT menu LED in block 3 keeps flashing.			9	0.1
			9	5.0

Since the difference between the leaving water temperature and the return water temperature is a measure of the building load, a setpoint reset based on the return water temperature is actually an reset method based on the average building load. As the building load falls from 100% to 0%, so the entering evaporator water temperature falls in proportion to the load. Thus a drop in temperature in the evaporator which is in general 5.5°C at full load would theoretic-ally become 0°C at zero load. In this event, the reset parameters are generally configured to deliver an reset with a negative slope:

- In cooling mode, the controller automatically resets the chilled water setpoint upwards in response to a drop in ΔT .
- In heating mode, the controller automatically resets the chilled water setpoint downwards in response to a rise in ΔT .

However, the reset parameters remain accessible to any type of configuration and make it possible to obtain any combination of slope and reset origin in response to fluctuations in the value of ΔT on the active heat exchanger.

Reset based on ΔT is a linear function which requires three parameters to be configured:

- A reference ΔT at which the reset is zero: this is the ΔT for zero reset referred to in item 10 for cooling mode or item 15 for heating mode.
- A reference ΔT at which the reset is at maximum: this is the ΔT for maximum reset referred to in item 11 for cooling mode or item 16 for heating mode.
- The maximum reset value: this is the maximum reset value referred to in item 12 for cooling mode - item 17 for heating mode.

Range: ΔT for zero reset:
0 to 13.8K
 ΔT for maximum reset:
0 to 13.8K
Maximum reset value:
-16.6 to 16.6K

The reset is calculated as follows if the value of the ΔT for zero reset exceeds the value of the ΔT for maximum reset (negative slope):

- The reset is zero if the current ΔT exceeds the reference value ΔT for zero reset.
- The reset equals the maximum reset value if the current ΔT is lower than the reference value ΔT for maximum reset.

- If the current ΔT is between the reference values ΔT for zero reset and ΔT for maximum reset, the reset value is calculated by linear interpolation between the maximum reset value and 0.

The reset is calculated as follows if the value of the ΔT for zero reset is lower than the value of the ΔT for maximum reset (positive slope):

- The reset is zero if the current ΔT is lower than the reference value ΔT for zero reset.
- The reset equals the maximum reset value if the current ΔT exceeds the reference value ΔT for maximum reset.
- If the current ΔT is between the reference values ΔT for zero reset and ΔT for maximum reset, the reset value is calculated by linear interpolation between 0 and the maximum reset value.

Sample ΔT reset configuration:

In this example, the cooling setpoint starts to be reset with effect from a ΔT at the evaporator of 5.0K (full load) up to a maximum reset of 3°C at a ΔT of 3.0K.

This example assumes that the:

- Reset based on ΔT has already been configured in the configuration menu (see section 4.2.10, configuration).

The configuration shall be as follows:

- Zero reset if the evaporator ΔT (i.e. ΔT for zero reset - Item 10) is greater than 5.0K;
- Maximum reset 3°C (Maximum reset value - Item 12) if the evaporator ΔT (i.e. ΔT for maximum reset - Item 11) is lower than 3.0K.

The setpoint curve is then as follows:

Cooling setpoint ΔT reset

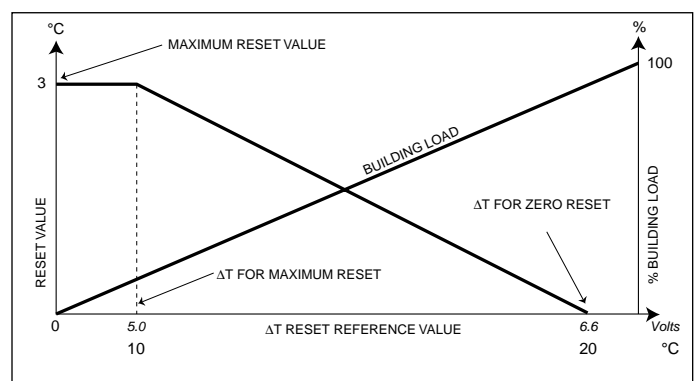

4.2.8 - Description of the INPUT menu

This menu displays the status of the controller inputs. Access to this menu is read-only.



ITEM	FORMAT	DESCRIPTION
0	b	Remote start/stop contact status
1	b	Remote cooling setpoint selection contact status
2*	b	Remote heat/cool selection contact status
3*	b	Remote reclaim mode selection contact status
4	b	Demand limit contact status
5	b	Interlock check contact status
6	nn.n	0-10 V d.c signal

Key:

* : This item is displayed in certain unit configurations only.
b : 0 = Open/Closed; 1 = Start/Stop

- Item 0 Remote start/stop contact status
This contact is used to select the following modes of operation when the unit is in remote operating type (rEM):
- Contact open: unit stop command
 - Contact closed: unit authorised to start up.
- See section 3.4.3 for a description of the connections for the remote start/stop contact.
- Item 1 Remote cooling setpoint selection contact status
This contact is used to select a cooling setpoint only when the unit is in cooling mode and remote operating type (rEM):
- Contact open: unit using cooling setpoint 1
 - Contact closed: unit using cooling setpoint 2
- This command is inactive if the unit is operating in heating mode.
- See section 3.4.4 for a description of the connections for the remote cooling setpoint selection contact.
- Item 2 Remote heat/cool selection contact status
This contact is used to select heating or cooling mode only when the unit is in remote operating type (rEM):
- Contact open: unit in cooling mode
 - Contact closed: unit in heating mode
- This command applies to heat pumps only.
- See section 3.4.5 for a description of the connections for the remote heat/cool selection contact.

- Item 3 Remote reclaim mode selection contact status
This contact is used to select the second condensing setpoint or reclaim mode (provided the unit is of the reclaim type) only when the unit is in cooling mode and remote operating type (rEM):
- Contact open: unit using normal condensing setpoint and in normal mode (no reclaim).
 - Contact closed: unit using reclaim setpoint and in reclaim mode.

See section 3.4.6 for a description of the connections for the remote condensation mode selection contact.

- Item 4 Demand limit contact status
When closed this contact limits the demand of the unit by reference to the value of the demand limit setpoint, if the contact method of demand limit has been selected (see section 4.2.10).
- Contact open: unit demand not limited
 - Contact closed: unit demand limited to the limit setting.

See section 4.2.7 for a description of demand limit setting and section 3.4.7 for a description of reduction contact connections.

NOTE

This contact is active in all operating types.

- Item 5 Interlock check contact status
When this contact opens the unit stops or is prevented from starting and an alarm is created. In general the contact is used to control the evaporator water flow.

See section 3.4.8 for a description of the connection for the lockout contact.

NOTE

This contact is active in all operating types.

- Item 6 External 0-10 V d.c. signal
This signal, which is from an external source, can be used (depending on the configuration) for:
- The reset function
 - Demand limit of the unit
- See section 4.2.10 for the configuration of the signal. See section 3.4.10 for a description of the connection for the 0-10 V d.c. signal.

NOTE

This contact is active in all operating types.

4.2.9 - Description of the OUTPUT/TEST menu

4.2.9.1 - General

This menu displays the status of the controller outputs. When the machine is **fully stopped** (LOFF) the outputs can be actioned for tests.



ITEM	FORMAT	DESCRIPTION
0	b ₁ b ₂ b ₃ b ₄	Status of circuit A compressors b ₁ : Compressor A1 b ₂ : Compressor A2 b ₃ : Compressor A3 b ₄ : Compressor A4
1*	b ₁ b ₂ b ₃ b ₄	Status of circuit B compressors b ₁ : Compressor B1 b ₂ : Compressor B2 b ₃ : Compressor B3 b ₄ : Compressor B4
2*	b ₁ b ₂	Unloader status circuits A & B b ₁ : UnloaderA1 b ₂ : Unloader A2
3*	b ₁ b ₂ b ₃ b ₄	Fan stages status circuit A b ₁ : Fan stage 1 b ₂ : Fan stage 2 b ₃ : Fan stage 3 b ₄ : Fan stage 4
4*	b ₁ b ₂ b ₃ b ₄	Fan stages status circuit B b ₁ : Fan stage 1 b ₂ : Fan stage 2 b ₃ : Fan stage 3 b ₄ : Fan stage 4
5	b ₁ b ₂	Alarm outputs status b ₁ : Circuit A b ₂ : Circuit B
6*	b ₁ b ₂	Solenoid valves status circuits A & B b ₁ : Circuit A b ₂ : Circuit B (units fitted with TXV only)
7*	nnn	EXV position circuit A (units fitted with EXV only)
8*	nnn	EXV position circuit B (units fitted with EXV only)
9*	nnn	Variable fan speed or condenser water valve position as % - Circuit A
10*	nnn	Variable fan speed or condenser water valve position as % - Circuit B
11*	b ₁ b ₂	Reversible reclaim valve status - Circuits A & B b ₁ : Circuit A b ₂ : Circuit B (units fitted with the reclaim module only).
12*	b ₁ b ₂	Reclaim mode bypass valve status - Circuits A & B b ₁ : Circuit A b ₂ : Circuit B (units fitted with the reclaim module only).
13	b	Evaporator pump status
14	b	Local interface test

Key:

* : This item is displayed in certain unit configurations only.
b : 0 = Open/Closed; 1 = Start/Stop
n : numerical display

Access to the tests is password controlled. The password must first have been entered in the Configuration menu (see section 4.2.10).

To carry out a test use the or buttons to access the output to be tested and press the button to activate modification mode. The Output/Test LED on the user interface starts to flash. Enter the required test value and press to start the test. The Output/Test LED stops flashing. Press , or to stop the test.

4.2.9.2 - Compressors

During the test phase, power to the compressor under test is only switched on for 8 to 10 seconds. Also this compressor cannot be restarted for a further 30 seconds.

Item 0 Status/Test of compressors - circuit A
Item 1 Status/Test of compressors - circuit B
These items display the status of the compressors on circuit A or B. They can also test them independently. Item 1 is not displayed on single-circuit units.

For example:

Test of compressors A2 and A3. The password must already have been entered in the Configuration menu. If not, the message “no” will be displayed in block 2 (see section 4.2.10).

OPERATION	PRESS KEY	BLOCK 3 LED	BLOCK 1 DISPLAY	BLOCK 2 DISPLAY
Hold down the MENU button until the LED for OUTPUTS/TESTS lights.			0	
			0	
Press the button to authorise modification of the value associated with item 0. The OUTPUTS/TESTS menu LED flashes to show that modification mode is active and the value can be modified.			0	0
Press until the value 100 is displayed in block 2. The LED for OUTPUTS/TESTS in block 3 keeps flashing to show that modification mode is active.			0	100
Press the button again. Compressor A3 starts and the LED for OUTPUTS/TESTS in block 3 stops flashing.			0	100
Press the button again. Compressor A3 stops and the LED for OUTPUTS/TESTS in block 3 starts flashing again.			0	100
Press until the value 10 is displayed in block 2. The LED for OUTPUTS/TESTS in block 3 keeps flashing.			0	10
Press the button to start compressor A2. The LED for OUTPUTS/TESTS in block 3 stops flashing.			0	10
Press to go to the next item and deactivate the compressor.			1	0

4.2.9.3 - Outputs other than compressors

The test procedure is as described above.

Item 2 Unloader status/test
This item displays the status of the unloaders installed on the lead compressors. It also tests them.

Item 3 Fan stages status/test circuit A
Item 4 Fan stages status/test circuit B
In test mode, the or buttons in block 4 display 1, 10, 100 and 1000 in succession, so as to force the various fan stages in turn on each circuit. These items only apply to air-cooled units. Item 4 is not displayed on single-circuit units.

Item 5 Alarm outputs status/test - Circuits A & B
In test mode, the \uparrow or \downarrow buttons in block 4 display 1, and 10 in succession, so as to force each alarm output status in turn on each circuit.

NOTE

The alarm B output is not used on units of the following types:

- Single circuit
- Water-cooled - 2 compressors - TXV: output A is used to report alarms for faults common to both circuits.
- Air-cooled - 2 compressors - TXV - 2 fan stages: output A is used to report alarms for faults common to both circuits.

Item 6 Solenoid valves status/test - Circuits A & B
In test mode, the \uparrow or \downarrow buttons in block 4 display “1” so as to force the valve to its maximum open position. Item 8 is not displayed on single-circuit units.

Item 7 EXV status/test - Circuit A
Item 8 EXV status/test - Circuit B
In test mode, the \uparrow or \downarrow buttons display “1” so as to force the valve to its maximum open position. Item 8 is not displayed on single-circuit units.

Item 9 Variable speed fan or condenser water valve status/test - Circuit A

Item 10 Variable speed fan or condenser water valve status/test - Circuit A
In test mode, each element can be tested at a value in the range 0 to 100%. Item 10 is not displayed on single-circuit units.

Item 11 Reclaim module four-way valves status/test - Circuits A & B
In test mode, the \uparrow or \downarrow buttons in block 4 display 1 and 10 in succession, so as to force each 4-way valve output status in turn on each circuit.

Item 12 Reclaim module bypass valve status/test - Circuits A & B
In test mode, the \uparrow or \downarrow buttons in block 4 display 1 and 10 in succession, so as to force each bypass valve status in turn on each circuit.

Item 13 Evaporator water pump status
In test mode, this item starts the pump. The number for item 13 flashes (in block 1 of the user interface) when the unit is in CCN operating mode and the pump is controlled (i.e. forced) by the CCN.

Item 14 Local interface test
This item is only used in test mode. It causes all the LEDs on the user interface to light up or flash, so as to check that they are working properly.

4.2.10 - Description of the CONFIGURATION menu

This menu can be used to display and modify user configurations.

A configuration can only be modified when the machine is fully stopped (LOFF). However, the password must have been entered in the Configuration menu in order to access this feature.















ITEM	FORMAT	DESCRIPTION
0	nn	Password «no» Password invalid «Good» Password valid
1*	b	Head pressure control method
2*	b	Lead/lag select
3*	b	Loading sequence select
4	nn	Delay at start-up in minutes
5	b	Select ramp loading
6	b	Select reset type
7	b	Select demand limit type
8	nn.n	Software version
9	nnn	Network element address
10	nnn	Network bus number

Key:

- * : This item is displayed in certain unit configurations only.
- b : 1=Yes; 0=No
- n : numerical display
- : characters

Item 0 Password
A password must be entered in order to access the test function or modify a user configuration. The password has a default value of 11. This value can be modified by Carrier Service with the aid of special tools. If the message “no” is displayed in block 2, it means that a password must be entered or was entered incorrectly. The message “Good” means that the password has been validly entered or that the password already entered is still valid. The controller automatically deactivates the password after 5 minutes without activity (i.e. no buttons pressed) or after powering up.

For example: “enter password”.

OPERATION	PRESS KEY	BLOCK 3 LED	BLOCK 1 DISPLAY	BLOCK 2 DISPLAY
Hold down the MENU button until the LED for Configuration lights. Block 2 displays "no", showing that the password must be entered			0	
			0	No
Press the  button to authorise modification of the value associated with item 0. The Configuration menu LED flashes to show that the value can be modified.			0	0
Press  until the value 11 is displayed in block 2. The Configuration menu LED keeps flashing.			0	11
Press the  button again to validate. The Configuration menu LED stops flashing. "Good" is displayed if the password is correct.			0	Good

- Item 1 Head pressure control method
 Default: 0 on air-cooled chillers otherwise 1.
 Range: 0 or 1
 Config.: 0 = depending on position of EXV
 1 = by setpoint

NOTE

Units fitted with TXV will use configuration 1. When the second condensing setpoint is selected (reclaim setting), the controller uses configuration 1 (control by setpoint) regardless of how this item is configured. The original configuration is used again when the first condensing setpoint is re-selected.

- Item 2 Select lead circuit
 Default: 0
 Range: 0, 1 or 2
 Config.: 0 = automatic depending on the number start-ups of each circuit
 1 = Circuit A leader
 2 = Circuit B leader

NOTE

Available only on dual-circuit units. The circuit with the largest number of unloaders will always be the lead circuit regardless of how this item is configured.

- Item 3 Circuit loading sequence
 Default: 0
 Range: 0 or 1
 Config.: 0 = Equal circuit loading
 1 = Priority loading on one circuit

NOTE

This configuration is not available on single-circuit units. If a unit is air-cooled and the saturated condensation temperature of any one of the circuits is less than 0°C when the circuit starts up, the priority loading sequence shall be used regardless of how this item is configured.

- Item 4 Delay at start-up delay
 Default: 2 minutes
 Range: 0 to 15 minutes

NOTE

This value is reinitialised after power up or when both circuits are halted by a local, remote or CCN command. No compressor will be started up until this pause has expired. However, the evaporator water pump command will be activated immediately. The safety lockout loop will not be checked until the pause has expired.

- Item 5 Select ramp loading
 Default: 0
 Range: 0 or 1
 Config.: 0 = Ramp disabled
 1 = Ramp enabled

NOTE

This configuration enables the ramp to be activated for heating and cooling modes: the maximum rate (in °C/minute) of temperature drop (in cooling mode) or temperature rise (in heating mode) for the water leaving the active heat exchanger. However, each mode has its own ramp setting which can be configured in the Configuration menu.

- Item 6 Leaving water temperature reset select
 Default: 0
 Range: 0, 1 or 2
 Config.: 0 = Reset not selected
 1 = Reset based on returning water temperature
 2 = Reset based on an external 0-10 V d.c. signal

NOTE

Reset based on a 0-10 V d.c. signal has precedence over 0-10 V d.c. demand limit: if 0-10 V d.c. reset has already been selected, then the selection of limitation by a 0-10 V d.c. signal will be automatically disabled.

- Item 7 Select demand limit type
 Default: 0
 Range: 0, 1 or 2
 Config.: 0 = Limitation not selected
 1 = Limitation based on an external contact
 2 = Limitation based on an external 0-10 V d.c. signal

NOTE

Limitation based on an external 0-10 V d.c. signal. With this configuration, a value of 0 volt will enable the unit to operate at full capacity (100%), and a value of 10 volts will limit demand completely (0%). Between these two values, limitation shall exhibit a linear slope. However, these reference voltage values (0 and 10 volts) are configurable

(by Carrier Service only), so that their upper and lower values or the direction of the limitation slope can be modified.

CAUTION

Reset based on a 0-10 V d.c. signal has precedence over 0-10 V d.c. demand limit: if 0-10 V d.c. reset has already been selected, then the selection of limitation by a 0-10 V d.c. signal will be automatically disabled.

Item 8 Software version number

NOTE

This item shows the number of the software version used by this controller. Access is read-only.

Item 9 CCN element address
Default: 1
Range: 1 to 239

NOTE

No two network elements can have the same element number and bus number at the same time.

Item 10 CCN bus number
Default: 1
Range: 0 to 239

NOTE

No two network elements can have the same element number and bus number at the same time.

4.2.11 - Description of the ALARMS menu

This menu can be used to display and reset up to 5 active alarms.



ITEM	FORMAT	DESCRIPTION
0	n «AL» «nOnE»	n alarms active/alarm resets No active alarms
1*	nnn	Active alarm code 1
2*	nnn	Active alarm code 2
3*	nnn	Active alarm code 3
4*	nnn	Active alarm code 4
5*	nnn	Active alarm code 5









Key:

n : numerical display
* : This item is displayed if the alarm is active

Item 0 Number of alarms active/Reset all alarms
This item displays the number of alarms active (e.g. “3 AL” means that 3 alarms are active) and also allows them to be reset even if the unit is operating. If there are no alarms active, “nOnE” is displayed in block 2.

To reset active alarms, press the  button twice in succession when this item is displayed.

For example: Reset active alarms

OPERATION	PRESS KEY	BLOCK 3 LED	BLOCK 1 DISPLAY	BLOCK 2 DISPLAY
Hold down the MENU button until the LED for Alarms lights. Block 2 displays the number of alarms active (2 alarms in this example).			0	
Press the  button to authorise the alarms to be reset. The Alarm menu LED flashes and 0 is displayed in block 2.			0	0
Press the  button again to validate the reset. The Alarm menu LED stops flashing. “Good” is displayed for two seconds, then ‘2AL’ and finally ‘no’.			0	Good then 2 AL then no

Items 1 to 5 Active alarm code number
See section 6.4 for a list and complete description of the alarm codes.

4.2.12 - Description of the ALARMS HISTORY menu

This menu lets you display the last 10 alarms to have been reset.



ITEM	FORMAT	DESCRIPTION
0*	nnn	Alarms history 1
1*	nnn	Alarms history 2
2*	nnn	Alarms history 3
3*	nnn	Alarms history 4
4*	nnn	Alarms history 5
5*	nnn	Alarms history 6
6*	nnn	Alarms history 7
7*	nnn	Alarms history 8
8*	nnn	Alarms history 9
9*	nnn	Alarms history 10

Key:

n : Numerical display
* : This item is displayed if the alarm exists

4.2.13 - Description of the OPERATING LOG menu

This menu lets you display the operating times and number of start-ups for the machine, circuits and compressors. The values displayed are divided by 10, so that numbers of hours or start-ups of less than 10 are displayed as 0.



ITEM	FORMAT	DESCRIPTION
0	nnnn	Number of unit operating hours /10
1	nnnn	Number of operating hours circuit A and compressor A1/10
2*	nnnn	Number of operating hours compressor A2 /10
3*	nnnn	Number of operating hours compressor A3 /10
4*	nnnn	Number of operating hours compressor A4 /10
5*	nnnn	Number of operating hours circuit A and compressor B1/10
6*	nnnn	Number of operating hours compressor B2 /10
7*	nnnn	Number of operating hours compressor B3 /10
8*	nnnn	Number of operating hours compressor B4 /10
9	nnnn	Number of unit start-ups /10
10	nnnn	Number of start-ups circuit A and compressor A1/10
11*	nnnn	Number of start-ups compressor A2 /10
12*	nnnn	Number of start-ups compressor A3 /10
13*	nnnn	Number of start-ups compressor A4 /10
14*	nnnn	Number of start-ups circuit B and compressor B1/10
15*	nnnn	Number of start-ups compressor B2 /10
16*	nnnn	Number of start-ups compressor B3 /10
17*	nnnn	Number of start-ups compressor B4 /10

Key:

n : Numerical display
* : This item is displayed in certain unit configurations only.

4.2.14 - Default user interface display

The default display is activated when the keypad has remained inactive for 5 minutes.

The user interface displays in turn:

- The heat exchanger leaving water temperature (evaporator in cooling mode and condenser in heating mode).

In addition:

- Active operating type: “LOFF”, “L-C1”, “L-C2”, “L-H”, “LC1r”, “LC2r”, “CCn”, “rEM”.
- “SM” of the unit is under the control of a System Manager (FSM or CSM III).
- “MASt” if the Master/Slave function has been activated and the unit is the master.
- “SLA” if the Master/Slave function has been activated and the unit is a slave.

4.3 - Summary interface

4.3.1 - General

The summary interface includes a mimic diagram of the unit, together with pushbuttons and LEDs. It gives quick access to the main operating parameters of the unit. The summary interface shown below is for a dual-circuit water-cooled unit.

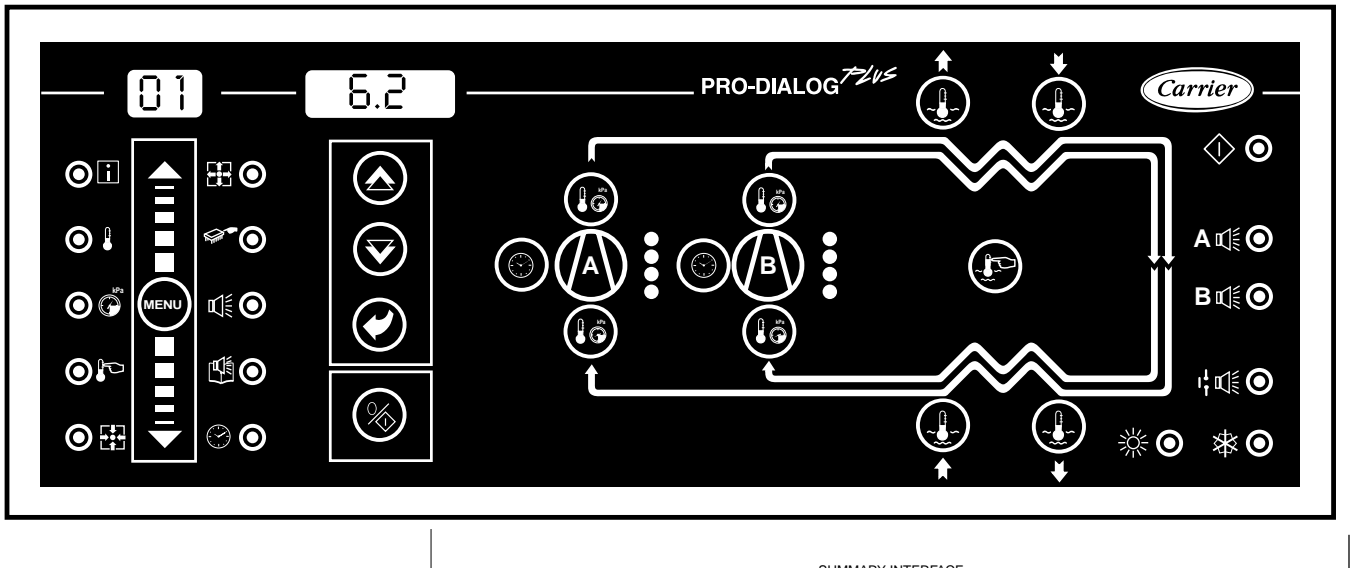

4.3.2 - Description of the LEDs

LED	INDICATION WHEN LIT
	Green LED: the unit is authorised to start or is already running
A	Red LED: <ul style="list-style-type: none"> • Lit = circuit A or unit shut down by alarm • Flashing = circuit A or unit running with alarm present
B	Red LED: <ul style="list-style-type: none"> • Lit = circuit B or unit shut down by alarm • Flashing = circuit B or unit running with alarm present
	Red LED: Lock contact open
	Green LED: the unit is in cooling mode
	Green LED: the unit is in heating mode
	Yellow LEDs: from top to bottom - start/stop status of compressors A1, A2, A3 & A4. A flashing LED indicates that the HP load shedding option is active on circuit A.
	Yellow LEDs: from top to bottom - start/stop status of compressors B1, B2, B3 & B4. A flashing LED indicates that the HP load shedding option is active on circuit B.

Key:
 * : LED available depending on unit configuration.

4.3.3 - The push buttons

The buttons allow immediate access to certain information (items) supplied by the main interface. Pressing one of these buttons causes the value of the item to be displayed immediately in block 2 and the number of the corresponding item to be displayed in block 1. It also lights the LED for the menu containing this information. Pressing the same button several times displays several pieces of information in succession.

LED	DISPLAY
	Evaporator/condenser leaving water temperature in °C
	Evaporator/condenser entering water temperature in °C
	Control point (setpoint + reset) in °C
	Press 1: Circuit A discharge pressure in kPa Press 2: Circuit A saturated condensing temperature in °C
	Press 1: Circuit A suction pressure in kPa* Press 2: Circuit A saturated suction temperature in °C*
	Press 1: Compressor A1/B1 operating hours in h/10* Press 2: Compressor A2/B2 operating hours in h/10* Press 3: Compressor A3/B3 operating hours in h/10* Press 4: Compressor A4/B4 operating hours in h/10*

Key:
 * : Button available depending on unit configuration.
 h : Hours

5 - PRO-DIALOG PLUS CONTROL OPERATION

5.1 - Start/stop control

The unit is in stop mode and is not authorised to start up if at least one of the following conditions is met:

- The unit is in Local Off operating type (LOFF): mode 1 is active.
- The unit is in operating type Remote (rEM) and the controller has received a stop command over a volt-free contact connected to the customer terminal block: mode 3 is active.
- The unit is in operating type CCN (CCn) and either:
 - the controller has received a stop command over the network: mode 2 is active; or
 - the controller has received a start command over the network but start/stop control by volt-free contact is authorised in CCN mode and the controller has received a stop command over a volt-free contact connected to the customer terminal block: mode 2 is active.
- The delay at start-up has not expired: mode 7 is active.
- The unit is in the process of switching from heating to cooling mode: it has completely stopped before restarting.
- CCN has commanded an emergency shutdown (EMSTOP activated).
- The unit is totally shut down due to an alarm.

The unit is authorised to start if it is not in stop mode (see above) and if one of the following conditions is met:

- The unit is in Local operating type (L-C1, L-C2, L-H, LC1r, LC2r): mode 4 is active.
- The unit is in Remote operating type (rEM) and the controller has received a start command over a volt-free contact connected to the customer terminal block: mode 6 is active.
- The unit is in CCN operating type (CCn) and the controller has received a start command over the network, and either:
 - start/stop control by volt-free contact is not authorised in mode CCN: mode 5 is active; or
 - start/stop control by volt-free contact is authorised in mode CCN and the controller has received a start command over a volt-free contact connected to the customer terminal block: mode 5 is active.

NOTE

In CCN operating mode, it is possible to authorise unit start/stop over a volt-free contact connected to the customer's terminal block. This configuration (which must be carried out by Carrier Service) is exceptional and generally only used for controlling a master unit in a master/slave grouping (see section 5.18).

5.2 - Heating/cooling selection

On heat pumps, heating/cooling selection can be controlled differently depending on the active operating type:

- Locally on the unit, using operating types L-C1, L-C2, LC1r and LC2r (for cooling) and L-H (for heating).
- Remotely using the heat/cool selection volt-free contact when the unit is in Remote operating type (rEM).
- Via a CCN command when the unit is in CCN operating type (CCn).

The current heat/cool operating mode on the unit is indicated by item 4 in the Information menu and by the heat/cool LEDs on the summary interface.

5.3 - Evaporator water pump control

The evaporator water pump is started when the unit is in the running mode described above or in delay at start-up mode (i.e. mode 7). Since the minimum value for the delay at start-up is 2 minutes (configurable between 2 and 15 minutes), the pump will run for at least two minutes before the first compressor starts. The pump is kept running for one minute after the unit goes to stop mode. The pump keeps working when the unit is switching from heating to cooling mode or vice-versa. It is turned off if the unit is shut down due to an alarm unless the fault is to do with frost protection. See section 5.18.3 for the particular cooler pump control for follower unit (master/slave assembly).

5.4 - Control interlock contact

This contact checks the status of a loop. It has the effect of preventing the unit from starting if it is open when the delay at start-up has expired. Also this contact must stay closed unless the unit is halted under Local, Remote or CCN control. If this contact is open for longer than 8 seconds whilst the unit is running, the defective unit is shut down at once.

5.5 - Control point

Control point represents the leaving water temperature that the unit must produce.

- In cooling mode: control point = active setpoint + reset
- In heating mode: control point = active setpoint - reset

5.5.1 - Active setpoint

Two setpoints can be selected as active in cooling mode. Usually, the second setpoint is used for unoccupied periods or for ice storage (medium or low brine unit). A single setpoint is available in heating mode.

Depending on the current operating mode, the active setpoint can be selected with the operating type selector button, or with the user's volt-free contacts, or with network commands (see section 4.2.7).

5.5.2 - Reset

Reset means that the active setpoint is modified in such a way that the capacity required by the unit is less (in cooling, the setpoint is increased, and in heating it is lowered). This modification is in general a reaction to a drop in the load. For the PRO-DIALOG control system, the source of the reset can be configured: it can be delivered either by an external 0-10 V d.c. signal (e.g. outside temperature probe) or by the return water temperature. In both cases the reset parameters, i.e. slope, source and maximum value, are configurable in the Setpoints menu (see section 4.2.7) and are also independent for the heating and cooling modes.

5.6 - Demand limit

Generally, demand limit is used by an energy management system in order to restrict the unit electricity consumption.

The PRO-DIALOG Plus control system for 30 G&H provides two methods of demand limit:

- By reference to a limiting signal from a user-controlled volt-free contact: the capacity of the unit cannot exceed the demand limit setpoint (which can be modified in the Setpoints menu) when the limit contact is closed.

- By reference to an external 0-10 V d.c. signal: the capacity of the unit cannot exceed the demand limit imposed by this external signal. It is a linear function and its parameters are configurable by Carrier Service (voltages at 0% limitation and 100% of limitation). This function is not available if Reset by reference to an external 0-10 V d.c. signal has already been selected.

Whatever the method used, demand limit is active in all operating types: Local, Remote or CCN. However, in Local operating type, demand limit can be disabled with keypad commands (see section 4.2.4) and in CCN operating type, demand limit can be controlled directly with the aid of CCN commands.

NOTE

A limitation value of 100% means that the unit may call upon the full array of its capacity stages.

Here is an example of demand limit by an external 0-10 V d.c. signal. This example assumes that the limitation parameters are such that at 0 volt the authorised capacity shall be maximum capacity, and at 10 volts the authorised capacity shall be zero (this is the default configuration).

Demand limit by 0-10 V d.c. signal

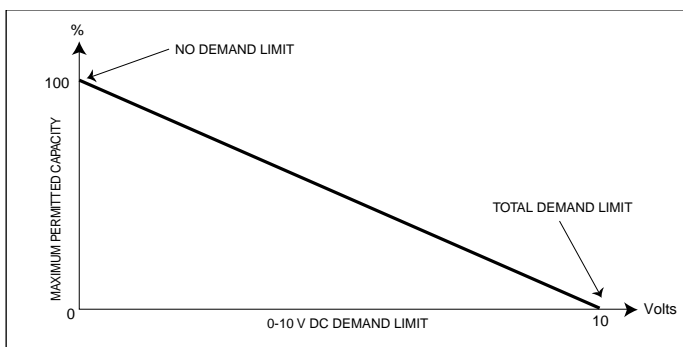

5.7 - Capacity control

This function adjust the number of active compressors and reduces capacity to keep the leaving water temperature at its setpoint. The **precision** with which this is achieved depends on **the capacity of the water loop, the flow rate, the load, and the number of stages available on the unit.**

The control system continuously takes account of the temperature error with respect to the setpoint, as well as the rate of change in this error and the difference between entering and leaving water temperatures, in order to determine the optimum moment at which to add or withdraw a capacity stage.

NOTE

If the same compressor undergoes too many starts (per hour) this automatically brings about reduction of compressor starts, which makes leaving water temperature control less precise.

5.8 - Determining the lead circuit

This function commands the start/stop sequence of the two refrigerant circuits called A and B. The circuit authorised to start first is the lead circuit. Three methods can be

configured by the user in the Configuration menu:

- **Auto mode:** the control system determines the lead circuit so as to equalise the number of starts on each circuit (value weighted by the operating times of each circuit). Thus, the circuit with the least number of starts is always given precedence to start. The lead circuit is stopped last. This function is only available on dual circuit units.
- **Circuit A as leader:** Circuit A is always the lead circuit. It is the first to start and the last to stop.
- **Circuit B as leader:** Circuit B is always the lead circuit. It is the first to start and the last to stop. This choice is only available on dual circuit units.

NOTE

If one circuit has more demand limits than the other, this circuit will always be the leader, regardless of the configuration and operating hours of the two circuits.

5.9 - Circuit loading sequence

Two circuit loading sequences are available. The choice of sequence can be configured by the user in the Configuration menu (see section 4.2.10). This function is only available on dual-circuit units.

- **Balanced circuit loading:** If this sequence is selected, the control system tries to keep the capacity of circuits A and B equal as the total load on the unit increases or decreases.
- **Loading with priority given to one circuit:** If this sequence is selected, the control system loads the lead circuit completely before the second circuit starts up. When there is a demand limit, the second circuit is unloaded first.

NOTE

If a unit is air-cooled and the saturated condensing temperature of either circuit is less than 0°C when a circuit starts up, the priority loading sequence shall be used regardless of how this item is configured.

5.10 - Lag compressor start-up sequence

Lag compressors are started and stopped in a sequence designed to equalise their number of start-ups (value weighted by their operating time).

5.11 - Controlling the EXV

EXVs, if used, control the flow of refrigerant in the evaporator. They are controlled in order to maintain a constant level of superheat at the thermistor for the lead compressor inlet gas (located between the compressor motor and the cylinders).

A thermistor and a pressure sensor, in the lead compressor of each circuit, are used to measure this superheat. The thermistor measures the temperature of the superheated gas entering the cylinders. The pressure sensor measures the suction gas pressure. The controller converts this value into a saturated temperature. The difference between the superheated gas temperature and the saturated temperature is the superheat. The control system sets the position of the EXV to hold this superheat at the setpoint configured for the unit.

Since the EXVs are driven by the controller their positions are always known. During start-up of a circuit its EXV is fully closed to ensure pump down. After pump down, the system continuously controls and monitors the valve position. Similarly, on shutdown of a circuit the EXV is closed again to ensure pumping down.

EXVs are also used to restrict suction temperature, making it possible to start the unit at higher water and suction temperatures without overloading the compressors. This procedure controls what is known as Maximum Operating Pressure (MOP).

5.12 - Head pressure control on air-cooled units

There are two configurable methods for controlling the condenser fans:

- **Controlling condensation by reference to a setpoint:** The saturated head pressure is controlled by reference to a fixed setpoint (user-definable in the Setpoints menu). This temperature is maintained by cycling fans on and off, as well as by varying the speed of a fan in appropriate cases.
- **Controlling condensation by reference to the position of the EXV:** The saturated head pressure is controlled by reference to the position of the EXV and the superheat, by cycling fans on and off as well as by varying the speed of a fan in appropriate cases. The control system seeks to keep the EXVs as wide open as possible whilst maintaining the correct level of superheat with the fans. Available only on units fitted with EXVs.

When the second condensing setpoint is selected (reclaim setting), the control system will automatically revert to controlling by reference to a setpoint even if control by reference to the EXV has been selected. The original configuration is reinitialised when the first condensing setpoint is re-selected.

NOTE

Certain units can have up to 4 fan stages and a variable speed fan per circuit, depending on their configuration and wiring.

5.13 - Head pressure control on water-cooled units

There are two configurable methods for controlling the condenser water valves (optional):

- **Controlling head pressure by reference to a setpoint:** Saturated head pressure is controlled by reference to a user-definable fixed setpoint. This temperature is maintained by using the valves to control the flow of water in each condenser circuit.
- **Controlling head pressure by reference to the position of the EXV:** Saturated head pressure is controlled by reference to the position of the EXV and the superheat, by adjusting the flow of water in each condenser circuit. The valve control system seeks to keep the EXVs as wide open as possible whilst maintaining the correct level of superheat with fans. Available only on units fitted with EXVs.

When the second head pressure setpoint is selected (reclaim setting), the control system will automatically revert to controlling by reference to a setpoint even if

control by reference to the EXV has been selected. The original configuration is reinitialised when the first head pressure setpoint is re-selected.

5.14 - Head pressure setpoint selection

There are two head pressure setpoints available: the first is called “head pressure setpoint” and the second “reclaim setpoint”. These setpoints only have an effect when the control system is controlling head pressure: air or water-cooled units operating in cooling mode (only when they are fitted with condenser water valves).

The active setpoint can be selected in one of the following ways:

- With the operating type selector button: selections L-C1 and L-C2 activate the head pressure setpoint. Selections LC1r and LC2r activate the reclaim setpoint (see section 4.2.2, description of the operating modes).
- With a volt-free selection contact connected to the customer terminal block when the unit is in Remote operating type (rEM). See section 3.4.4, description of the control contacts.
- With a network command when the unit is in CCN operating type (CCn).

When the reclaim setpoint is selected:

- Mode 12 is active.
- Head pressure is controlled by reference to a setpoint even if control by reference to the EXV has been selected.
- If the heat reclaim module option is installed, then all functions associated with this module are activated (see description in section 5.15).

5.15 - Heat reclaim module option

This option applies only to air-cooled units fitted with independent fan stages and a maximum of 4 compressors. The option can be configured to apply to just one or all cooling circuits.

It will be necessary to install an optional 4xDO board to control per circuit:

- A 4-way valve. This valve directs the refrigerant to the active heat exchanger: either the air-cooled heat exchanger in non-reclaim mode or the water-cooled exchanger in reclaim mode.
- A hot gas bypass valve. When the unit is switching from reclaim to non-reclaim mode or vice-versa, this valve makes it possible to purge the refrigerant load from the unused heat exchanger (this operation is called the injection phase). This ensures that the refrigerant load is correctly located regardless of the operating mode.

When the reclaim function is selected (mode 12 active - see section 5.14):

- **The reclaim function is active** when: the reclaim unit leaving water temperature is below the reclaim setpoint less half the reclaim dead band. Mode 13 is active.
- **The reclaim function is not active** when the reclaim unit leaving water temperature is above the reclaim setpoint plus half the reclaim dead band. Mode 13 is not active.
- **In the dead band**, the function stays in its current status.

The dead band default value is 2.2°C. This value can be modified by Carrier Service.

Switching from active to non-active reclaim mode or vice-versa affects both circuits at the same time (if the option applies to both circuits) and initiates transitional operating phases (injection phases) during which the 4-way valves and bypass valves are activated in sequence. These phases last predetermined lengths of time which can be parameterised to match the control function to the installation. Such modifications must be carried out by Carrier Service. Injection sequences only take place when the circuit is running (i.e. at least one compressor operating). Any changeover sequence must be completed without interruption once started, otherwise it will be restarted automatically from the beginning. More than three interruptions will cause an alarm.

5.16 - High pressure load shedding option

This option does not require an additional board. When validated and parameterised (by Carrier Service) it prevents high pressure breaks on a circuit by the following means:

- Preventing any capacity increase on the circuit once the high pressure value has reached an initial threshold.
- Shedding one or more slave compressors once a further protection threshold has been reached.

In the event of a compressor load being shed, no capacity increase will be authorised on the circuit concerned for a period of 10 minutes.

NOTE

A lead compressor cannot be shed by this protection function.

5.17 - Pumping down

This function applies only to units that have been configured to pump down the cooling circuits (factory configuration). Where this applies, when the lead compressor in each circuit is started or stopped, that circuit goes through a pumping down cycle to purge the evaporator and suction line of refrigerant. The maximum duration of this cycle is 3 minutes.

5.18 - Master/slave assembly

5.18.1 - General

Two PRO-DIALOG Plus units can be linked to produce a master/slave assembly. This feature is only authorised in cooling mode. The two machines are interconnected over the CCN bus. To operate as master/slave, both units must have their chilled water temperature probes located on the common evaporator entering and leaving line. In addition interlock control of the cooler water flow and a freeze protection switch is imperative on each unit.

About Master / Slave units in parallel mounted for which water pumps are not with Pro-dialog Plus controlled, please check that water flow is stopped when the unit is shut down. The master/slave link only operates when both units are in CCN operating mode. The master/slave assembly will be inactive in the following cases:

- If either of the chillers is in Local or Remote mode, or in heating mode.
- A demand limit command is sent to the slave unit.
- One of the following CCN variables is forced on the slave unit: start unit, demand limit or control point.

All control commands to the master/slave assembly (start/stop, setpoint, load shedding, etc.) are handled by the unit which is configured as the master, and must therefore only be applied to the master unit. They will be transmitted automatically to the slave unit. Therefore to start up the assembly, simply validate operating mode CCN (i.e. CCN) on the master unit (with the CCN start/stop variable previously forced to Enable). The slave unit stays in CCN operating type continuously. To stop the master/slave assembly, select Local Off (LOFF) on the master unit. In some cases with a specific configuration, remote volt-free contacts can be used to control unit start/stop or to select setpoint 1 or 2, even though both units are still in CCN operating mode.

NOTE

All parameters required for the master/slave function must be configured by Carrier Service.

5.18.2 - Balancing running times between master and slave

The master unit (depending on its configuration) may have as part of its functions to designate whether the master or slave is to be the head machine or the follower. The roles of head machine and follower will be reversed when the difference in running hours between the two units exceeds a configurable value, ensuring that the running times of the two chillers are automatically equalised. The changeover between head machine and follower may take place when the assembly is started up, or even whilst running.

The running time balancing function is not active when:

- It has not been configured: in this case the head machine is always the master unit.
- A demand limit is applied to the master unit: in this case the head machine will always be the master unit until the demand limit is lifted.

5.18.3 - Starting the follower unit

The head machine will always be started first. When the head machine is at its full available capacity, the start-up pause (configurable) is started on the follower. When this pause has expired, and if the error on the control point is greater than 1.1°C, the follower unit is authorised to start. At this time the follower unit cooler pump is turned on. The follower will automatically use the master unit's active setpoint. The head machine will be held at its full available capacity for so long as the active capacity on the follower is not zero. When the follower unit is commanded to stop, its cooler water pump is turned off with one minute delay.

5.18.4 - Abnormal operating conditions

In the event of a communication fault between the two units, each shall return to an autonomous operating mode until the fault is cleared. If the master unit is halted due to an alarm, the slave unit shall be authorised to start without prior conditions.

5.19 - Controlling a Pro-Dialog Plus unit with a System Manager

Up to 8 PRO-DIALOG Plus units (or System Manager compatibles) can be controlled by one control module of the FSM or CSM III type which can handle multi-tasking of control functions such as starting units in sequence.

6 - DIAGNOSTICS - TROUBLESHOOTING

6.1 - GENERAL

The PRO-DIALOG Plus control system has many fault tracing aid functions. The local interface and its various menus give access to all the units operating conditions. The test function makes it possible to run a quick test of all the devices on the unit.

If an operating fault is detected, an alarm is activated and an alarm code is stored in the Alarm menu.

6.2 - Displaying alarms

The alarm LEDs on the summary interface (see section 4.3.2) give a quick display of the status of each circuit and the unit as a whole.









- A flashing LED shows that the circuit is operating but there is an alarm.
- A steady LED shows that the circuit has been shut down due to a fault.

The Alarm menu on the main interface displays up to 5 fault codes that are active on the unit.

6.3 - Resetting alarms

When the cause of the alarm has been corrected the alarm can be reset, depending on the type, either automatically on return to normal, or manually when action has been taken on the unit.

A manual reset must be run from the main interface using the following procedure:

OPERATION	PRESS KEY	BLOCK 3 LED	BLOCK 1 DISPLAY	BLOCK 2 DISPLAY
Hold down the MENU button until the LED for Alarms lights. Block 2 displays the number of alarms active (2 alarms in this example).	 		0	
Press the  button to authorise the alarms to be reset. The Alarm menu LED flashes and 0 is displayed in block 2.			0	0
Press the  button again to validate the reset. The Alarm menu LED stops flashing. "Good" is displayed for two seconds, then '2AL' again, and finally 'no'.			0	Good then 2 AL then no

Alarms can be reset even if the unit is running. This means that an alarm can be reset without stopping the machine.

In the event of a power supply interrupt, the unit restarts automatically without the need for an external command. However, any faults active when the supply is interrupted are saved and may in certain cases prevent a circuit or unit from restarting.

6.4 - Alarm codes

The following list gives a complete description of each alarm code and its possible cause.

ALARM CODE DESCRIPTIONS

Code	Description	Action	Pump down	Reset	Probable cause
1	Evaporator leaving water thermistor fault	Unit shutdown	Yes	Auto	Thermistor fault, wiring error or bad connection
2	Evaporator entering water thermistor fault	Unit shutdown	Yes	Auto	Ditto
3	Condenser leaving water thermistor fault	Heating mode: unit stop Cooling mode: no action	Yes -	Auto	Ditto
4	Condenser entering water thermistor fault	Heating mode: deactivate ΔT reset Otherwise, no action	-	Auto	Ditto
5	Suction thermistor fault, compressor A1	Circuit A shutdown	Yes	Auto	Ditto
6	Suction thermistor fault, compressor B1	Circuit B shutdown	Yes	Auto	Ditto
7	Heat reclaim unit leaving water thermistor fault	Unit with heat reclaim option: unit shutdown Otherwise, no action		Yes - Auto	Ditto
8	Heat reclaim unit leaving water thermistor fault	No action	-	Auto	Ditto
9	External 0-10 V d.c. signal fault	Reset: use normal setpoint Demand limit: disable	No	Auto	Incorrect signal, wiring error
10	Discharge pressure sensor fault, circuit A	Shutdown circuit A	Yes	Auto	Sensor fault or wiring error
11	Discharge pressure sensor fault, circuit B	Shutdown circuit B	Yes	Auto	Ditto
12	Suction pressure sensor fault, circuit A	Shutdown circuit A	No	Auto	Ditto
13	Suction pressure sensor fault, circuit B	Shutdown circuit B	No	Auto	Ditto
14	Oil pressure sensor fault, compressor A1	Shutdown circuit A	No	Auto	Ditto
15	Oil pressure sensor fault, compressor B1	Shutdown circuit B	No	Auto	Ditto
16	Oil pressure sensor fault, compressor A2	Shutdown compressor A2	-	Auto	Ditto
17	Oil pressure sensor fault, compressor B2	Shutdown compressor B2	-	Auto	Ditto
18	Oil pressure sensor fault, compressor A3	Shutdown compressor A3	-	Auto	Ditto
19	Oil pressure sensor fault, compressor B3	Shutdown compressor B3	-	Auto	Ditto
20	Oil pressure sensor fault, compressor A4	Shutdown compressor A4	-	Auto	Ditto
21	Oil pressure sensor fault, compressor B4	Shutdown compressor B4	-	Auto	Ditto
22	Pressure sensor 5 volt power supply fault	Unit shutdown	No	Auto	Faulty board
23	Loss of communication with compressor board 1	Shutdown circuit A	No	Auto	Wiring error, faulty module or incorrect module address
24	Loss of communication with compressor board 2	Shutdown compressor A2	-	Auto	Ditto
25	Loss of communication with compressor board 3	Shutdown compressor A3	-	Auto	Ditto
26	Loss of communication with compressor board 4	Shutdown compressor A4	-	Auto	Ditto
27	Loss of communication with compressor board 5	Shutdown circuit B	No	Auto	Ditto
28	Loss of communication with compressor board 6	Shutdown compressor B2	-	Auto	Ditto
29	Loss of communication with compressor board 7	Shutdown compressor B3	-	Auto	Ditto
30	Loss of communication with compressor board 8	Shutdown compressor B4	-	Auto	Ditto
31	Loss of communication with 4xDO board No. 1	Shutdown circuit A	No	Auto	Ditto
32	Loss of communication with 4xDO board No. 2	Shutdown circuit B	No	Auto	Ditto
33	Loss of communication with 4xDO board No. 3	Shutdown circuit A or unit depending on configuration	No	Auto	Ditto
34	Loss of communication with 4xDO board No. 4	Shutdown circuit B	No	Auto	Ditto
35	Loss of communication with 4xAI-2xAO board No.1	Shutdown circuit A or unit depending on configuration	Unit shutdown or no action	No	Auto Ditto
36	Loss of communication with 4xAI-2xAO board No. 2	Shutdown circuit A or unit depending on configuration	Shutdown compressor or no action	No	Auto Ditto
37	Loss of communication with 4xAI-2xAO board No. 3	Shutdown circuit A or unit depending on configuration	Shutdown compressor	No	Auto Ditto
38	Low pressure fault, circuit A	Shutdown circuit A	No	Auto 1st time then manual*	Low refrigerant charge, faulty EXV or blocked filter
39	Low pressure fault, circuit B	Shutdown circuit B	No	Auto 1st time then manual*	Ditto
40	Pump down fault, circuit A	Shutdown circuit A	No	Manual	EXV or sensor faulty
41	Pump down fault, circuit B	Shutdown circuit B	No	Manual	Ditto
42	Evaporator anti-freeze protection	Unit shutdown	No	Auto 1st time then manual*	Low water flow rate or faulty thermistor
43	Low evaporator water flow rate	Unit shutdown	No	Manual	Water pump faulty
44	Low suction temperature, circuit A	Shutdown circuit A	No	Manual	Low charge, blocked filter or faulty thermistor
45	Low suction temperature, circuit B	Shutdown circuit B	No	Manual	Ditto
46	High suction superheat, circuit A	Shutdown circuit A	Yes	Manual	Ditto
47	High suction superheat, circuit B	Shutdown circuit B	Yes	Manual	Ditto
48	Low suction superheat, circuit A	Shutdown circuit A	Yes	Manual	EXV or thermistor or transducer faulty
49	Low suction superheat, circuit B	Shutdown circuit B	Yes	Manual	Ditto
50	Low oil pressure, compressor A1 EXV,	Shutdown circuit A	No	Manual	Faulty compressor, crankcase heater, pressure sensor or too much refrigerant, low oil level
51	Low oil pressure, compressor B1	Shutdown circuit B	No	Manual	Ditto
52	Low oil pressure, compressor A2	Shutdown compressor A2	-	Manual	Ditto
53	Low oil pressure, compressor B2	Shutdown compressor B2	-	Manual	Ditto
54	Low oil pressure, compressor A3	Shutdown compressor A3	-	Manual	Ditto
55	Low oil pressure, compressor B3	Shutdown compressor B3	-	Manual	Ditto
56	Low oil pressure, compressor A4	Shutdown compressor A4	-	Manual	Ditto
57	Low oil pressure, compressor B4	Shutdown compressor B4	-	Manual	Ditto
58	Safety lockout control loop open	Unit shutdown	No	Manual	Evaporator water flow fault
59	Reclaim mode injection phase fault - circuit A	Shutdown circuit A	No	Manual	Power supply interrupted, circuit shutdown
60	Reclaim mode injection phase fault - circuit B	Shutdown circuit B	No	Manual	Ditto
61	Emergency stop	Unit shutdown	No	CCN	CCN command
62	Loss of communication with 4xDO board No. 5	Unit shutdown	No	Auto	See faults 23 to 37
63	Loss of communication with the System Manager	Unit runs in autonomous mode	Unit runs in autonomous mode	- Auto	CCN fault
64	Loss of communication with the slave	Unit runs in autonomous mode	-	Auto	CCN fault

Key:

Manual, if this fault has occurred previously the same day, otherwise automatic

ALARM CODE DESCRIPTIONS

Code	Description	Action	Pump down	Reset	Probable cause
101	Fault, compressor A1 - GCP board crankcase gas thermostat	Shutdown, circuit A	No	Manual	- GCP module fault: Open contact on residual current detector - Starter Guard fault: Open contact on detector board for heater and motor current fault - High pressure switch fault: Open contact on high pressure switch - Discharge gas thermostat: Open contact on discharge
102	Fault, compressor A1 - Starter Guard	Shutdown, circuit A	No	Manual	Ditto
103	Fault, compressor A1 - HP	Shutdown, circuit A	No	Manual	Ditto
104	Fault, compressor A1 - DGT	Shutdown, circuit A	No	Manual	Ditto
202	Fault, compressor A2 - Starter Guard	Shutdown, compressor A2	-	Manual	Ditto
204	Fault, compressor A2 - DGT	Shutdown, compressor A2	-	Manual	Ditto
302	Fault, compressor A3 - Starter Guard	Shutdown, compressor A3	-	Manual	Ditto
304	Fault, compressor A3 - DGT	Shutdown, compressor A3	-	Manual	Ditto
402	Fault, compressor A4 - Starter Guard	Shutdown, compressor A4	-	Manual	Ditto
404	Fault, compressor A4 - DGT	Shutdown, compressor A4	-	Manual	Ditto
501	Fault, compressor B1 - GCP	Shutdown, circuit B	No	Manual	Ditto
502	Fault, compressor B1 - Starter Guard	Shutdown, circuit B	No	Manual	Ditto
503	Fault, compressor B1 - HP	Shutdown, circuit B	No	Manual	Ditto
504	Fault, compressor B1 - DGT	Shutdown, circuit B	No	Manual	Ditto
602	Fault, compressor B2 - Starter Guard	Shutdown, compressor B2	-	Manual	Ditto
604	Fault, compressor B2 - DGT	Shutdown, compressor B2	-	Manual	Ditto
702	Fault, compressor B3 - Starter Guard	Shutdown, compressor B3	-	Manual	Ditto
704	Fault, compressor B3 - DGT	Shutdown, compressor B3	-	Manual	Ditto
802	Fault, compressor B4 - Starter Guard	Shutdown, compressor B4	-	Manual	Ditto
804	Fault, compressor B4 - DGT	Shutdown, compressor B4	-	Manual	Ditto

6.4.1 - Sensor faults

Alarm 1 Evaporator leaving water thermistor fault Alarm 2 Evaporator entering water thermistor fault

Description: The temperature measured by these sensors is outside the range -40 to 116°C.
Action: Unit has stopped pumping down.
Reset: Automatic if temperature measured by sensor returns to admissible value range.
Probable cause: Faulty thermistor, wiring error or disconnection.

Alarm 3 Condenser leaving water thermistor fault

Description: The temperature measured by the sensor is outside the range -40 to 116°C.
Action:

- Situation 1: If the unit is a heat pump in heating mode the unit is stopped with pumping down.
- Situation 2: If the sensor is optional, no action.

Reset: Automatic if temperature measured by sensor returns to admissible value range.
Probable cause: Faulty thermistor, wiring error or disconnection.

Alarm 4 Condenser entering water thermistor fault

Description: The temperature measured by the sensor is outside the range -40 to 116°C.
Action:

- Situation 1: If the unit is a heat pump in heating mode the unit keeps running. The capacity control system uses a default capacity control coefficient.
- Situation 2: If the unit is a heat pump in heating mode and the reset function based on ΔT is in use, the reset function is disabled and the active heating setpoint is used.
- Situation 3: If the sensor is optional, no action.

Reset: Automatic if temperature measured by sensor returns to admissible value range.
Probable cause: Faulty thermistor, wiring error or disconnection.

Alarm 5 Compressor A1 thermistor fault Alarm 6 Compressor B1 thermistor fault

Description: The unit is using EXVs and the temperature measured by the sensor in the lead compressor is outside the range -40 to 116°C.
Action: Circuit is stopped with pumping down.
Reset: Automatic if temperature measured by sensor returns to admissible value range.
Probable cause: Faulty thermistor, wiring error or disconnection.

Alarm 7 Heat reclaim unit leaving water thermistor fault

Description: The temperature measured by the sensors is outside the range -40 to 116°C.
Action:

- Situation 1: If the unit is fitted and configured with the heat reclaim module option, the unit is stopped with pumping down.
- Situation 2: If the sensor is optional, no action.

Reset: Automatic if temperature measured by sensor returns to admissible value range.
Probable cause: Faulty thermistor, wiring error or disconnection.

Alarm 8 Heat reclaim unit entering water thermistor fault

Description: The temperature measured by the sensors is outside the range -40 to 116°C.
Action: No action
Reset: Automatic if temperature measured by sensor returns to admissible value range.
Probable cause: Faulty thermistor, wiring error or disconnection.

Alarm 9 External 0-10 V d.c. signal fault
 Description: The setpoint reset or demand limit function based on a 0-10 V d.c. signal is in use and the signal is outside the range -2.0 to 12.0 volts.
 Action:

- Situation 1: If the reset function based on a 0-10 V d.c. signal is in use, the reset function is disabled and the active setpoint is used.
- Situation 2: If the demand limit function based on a 0-10 V d.c. signal is in use, this function is disabled and the unit is authorised to operate at 100% of its capacity.

 Reset: Automatic if 0-10 V d.c. signal returns to admissible value range.
 Probable cause: Incorrect external signal, faulty temperature probe, wiring error.

Alarm 10 Circuit A discharge pressure sensor fault
Alarm 11 Circuit B discharge pressure sensor fault
 Description: The voltage delivered by the sensor is 0 volt.
 Action: The circuit is stopped after pumping down.
 Reset: Automatic if the voltage delivered by the probe returns to normal.
 Probable cause: Faulty sensor, wiring error or disconnection.

Alarm 12 Circuit A suction pressure sensor fault
Alarm 13 Circuit B suction pressure sensor fault
 Description: The value read by the sensor is below -5 kPa for 2 minutes.
 Action: The circuit is stopped without pumping down.
 Reset: Automatic if value measured by sensor returns to admissible value range. Pump down takes place on restarting.
 Probable cause: Faulty sensor, wiring error or disconnection.

Alarm 14 Compressor A1 oil pressure sensor fault
Alarm 15 Compressor B1 oil pressure sensor fault
 Description: The compressor is fitted with an oil pressure sensor and the voltage delivered by the sensor is 0 volt.
 Action: The circuit is stopped without pumping down.
 Reset: Automatic if voltage delivered by sensor returns to normal. Pump down takes place on restarting.
 Probable cause: Faulty sensor, wiring error or disconnection.

Alarm 16 Compressor A2 oil pressure sensor fault
Alarm 17 Compressor B2 oil pressure sensor fault
Alarm 18 Compressor A3 oil pressure sensor fault
Alarm 19 Compressor B3 oil pressure sensor fault
Alarm 20 Compressor A4 oil pressure sensor fault
Alarm 21 Compressor B4 oil pressure sensor fault
 Description: The compressor is fitted with an oil pressure sensor and the voltage delivered by the sensor is 0 volt.
 Action: The compressor is stopped.
 Reset: Automatic if voltage delivered by sensor returns to normal.
 Probable cause: Faulty sensor, wiring error or disconnection.

Alarm 22 Sensor power supply voltage fault
 Description: The power supply voltage to the pressure sensors is outside the range 4.5 to 5.5 volts.
 Action: The unit is stopped without pumping down.
 Reset: Automatic if voltage returns to normal. Pump down takes place on restarting.
 Probable cause: Faulty basic board.

6.4.2 - Communication faults

Alarm 23 Loss of communication with compressor board 1 (A1)
 Description: Communication has been lost with compressor board 1.
 Action: Circuit A is stopped without pumping down.
 Reset: Automatic if communication is re-established. Pump down takes place on restarting.
 Probable cause: Bad connection, wiring error, incorrect board address or faulty board.

Alarm 24 Loss of communication with compressor board 2 (A2)

Alarm 25 Loss of communication with compressor board 3 (A3)

Alarm 26 Loss of communication with compressor board 4 (A4)

Description: Communication has been lost with compressor board 1, 2 or 3.
 Action: The compressor connected to the board is stopped.
 Reset: Automatic if communication is re-established.
 Probable cause: Bad connection, wiring error, incorrect board address or faulty board.

Alarm 27 Loss of communication with compressor board 5 (B1)

Description: Communication has been lost with compressor board 5.
 Action: Circuit B is stopped without pumping down.
 Reset: Automatic if communication is re-established. Pump down takes place on restarting.
 Probable cause: Bad connection, wiring error, incorrect board address or faulty board.

Alarm 28 Loss of communication with compressor board 6 (B2)

Alarm 29 Loss of communication with compressor board 7 (B3)

Alarm 30 Loss of communication with compressor board 8 (B4)

Description: Communication has been lost with compressor board 6, 7 or 8.
 Action: The compressor connected to the board is stopped.
 Reset: Automatic if communication is re-established.
 Probable cause: Bad connection, wiring error, incorrect board address or faulty board.

<p>Alarm 31 Loss of communication with 4xDO board No. 1 (EXV control board circuit A)</p> <p>Alarm 32 Loss of communication with 4xDO board No. 2 (EXV control board circuit B)</p> <p>Description: The unit is using EXVs and communication has been lost with 4xDO board No.1 or 2.</p> <p>Action: Circuit A (alarm 31) or B (alarm 32) is stopped without pumping down.</p> <p>Reset: Automatic if communication is re-established. Pump down takes place on restarting.</p> <p>Probable cause: Bad connection, wiring error, incorrect board address or faulty board.</p>	<p>Alarm 35 Loss of communication with 4xAI-2xAO board No. 1</p> <p>Description: 4xAI-2xAO board No.1 is used and communication has been lost with that board.</p> <p>Action: • Situation 1: If the unit is a heat pump in heating mode and the condenser probes are connected to this board, the unit is stopped without pumping down. • Situation 2: If the unit uses oil pressure sensors that are connected to this board and also control lead compressors, the unit is stopped without pumping down. • Situation 3: If the unit uses oil pressure sensors that are connected to this board and control slave compressors, these slave compressors are stopped. • Situation 4: If the unit uses heat reclaim sensors connected to this board, and if the unit is fitted and configured with the heat reclaim module option, the machine is stopped with pumping down. • Situation 5: If the unit controls variable speed fans or water valves, the unit is stopped without pumping down. • Situation 6: If none of the above conditions is verified, the alarm is reported but no action is taken.</p> <p>Reset: Automatic if communication is re-established. Pump down takes place on restarting for situations 1, 2 and 4.</p> <p>Probable cause: Bad connection, wiring error, incorrect board address or faulty board.</p>
<p>Alarm 33 Loss of communication with 4xDO board No.3 (fan board)</p> <p>Description: 4xDO board No.3 is used and communication has been lost with that board.</p> <p>Action: • Situation 1: If the unit is configured and fitted with two independent fan stages per circuit, the unit is stopped without pumping down. • Situation 2: If the unit is configured and fitted with three or four independent fan stages per circuit, then circuit A is stopped without pumping down. • Situation 3: If the unit is configured and fitted with fan stages common to both circuits, the unit is stopped without pumping down.</p> <p>Reset: Automatic if communication is re-established. Pump down takes place on restarting.</p> <p>Probable cause: Bad connection, wiring error, incorrect board address or faulty board.</p>	<p>Alarm 36 Loss of communication with 4xAI-2xAO board No. 2</p> <p>Description: 4xAI-2xAO board No. 2 is used and communication has been lost with that board.</p> <p>Action: • Situation 1: If the unit uses oil pressure sensors connected to this board, the compressors attached to these sensors are stopped. • Situation 2: If none of the above conditions is verified, the alarm is reported but no action is taken.</p> <p>Reset: Automatic if communication is re-established.</p> <p>Probable cause: Bad connection, wiring error, incorrect board address or faulty board.</p>
<p>Alarm 34 Loss of communication with 4xDO board No. 4 (fan board circuit B)</p> <p>Description: 4xDO board No. 4 is used and communication has been lost with that board.</p> <p>Action: Circuit B is stopped without pumping down.</p> <p>Reset: Automatic if communication is re-established. Pump down takes place on restarting.</p> <p>Probable cause: Bad connection, wiring error, incorrect board address or faulty board.</p>	<p>Alarm 37 Loss of communication with 4xAI-2xAO board No. 3</p> <p>Description: 4xAI-2xAO board No. 3 is used and communication has been lost with that board.</p> <p>Action: If the unit uses oil pressure sensors that are connected to this board and control slave compressors, these slave compressors are stopped.</p> <p>Reset: Automatic if communication is re-established.</p> <p>Probable cause: Bad connection, wiring error, incorrect board address or faulty board.</p>
<p>Alarm 62 Loss of communication with 4xDO board No. 5 (reclaim module board)</p> <p>Description: 4xDO board No. 5 is used and communication has been lost with that board.</p> <p>Action: Unit is stopped without pumping down.</p> <p>Reset: Automatic if communication is re-established. Pump down takes place on restarting.</p> <p>Probable cause: Bad connection, wiring error, incorrect board address or faulty board.</p>	<p>Alarm 35 Loss of communication with 4xAI-2xAO board No. 1</p> <p>Description: 4xAI-2xAO board No.1 is used and communication has been lost with that board.</p> <p>Action: • Situation 1: If the unit is a heat pump in heating mode and the condenser probes are connected to this board, the unit is stopped without pumping down. • Situation 2: If the unit uses oil pressure sensors that are connected to this board and also control lead compressors, the unit is stopped without pumping down. • Situation 3: If the unit uses oil pressure sensors that are connected to this board and control slave compressors, these slave compressors are stopped. • Situation 4: If the unit uses heat reclaim sensors connected to this board, and if the unit is fitted and configured with the heat reclaim module option, the machine is stopped with pumping down. • Situation 5: If the unit controls variable speed fans or water valves, the unit is stopped without pumping down. • Situation 6: If none of the above conditions is verified, the alarm is reported but no action is taken.</p> <p>Reset: Automatic if communication is re-established. Pump down takes place on restarting for situations 1, 2 and 4.</p> <p>Probable cause: Bad connection, wiring error, incorrect board address or faulty board.</p>

6.4.3 - Control faults

Alarm 38 Low pressure fault, circuit A
 Alarm 39 Low pressure fault, circuit B
 Description: The circuit is running and suction pressure is less than the low pressure threshold (factory configuration) for more than 3 minutes.
 Action: The circuit is stopped without pumping down.
 Reset: Automatic when suction pressure is 10 psig (67 kPa) above the low pressure threshold and if the same fault has not occurred during the same day. Pumping down takes place on restarting. Manual reset if the fault has already occurred during the same day. Pumping down takes place on restarting.
 Probable cause: Shortage of refrigerant, blocked filter, faulty EXV or pressure sensor.

Alarm 40 Pump down fault, circuit A
 Alarm 41 Pump down fault, circuit B
 Description: Pumping down end condition not satisfied.
 Action: The circuit is stopped.
 Reset: Manual. Pumping down takes place on restarting.
 Probable cause: Faulty EXV or pressure sensor.

Alarm 42 Evaporator anti-freeze protection
 Water anti-freeze threshold - Tube evaporator: 1.1°C
 Water anti-freeze threshold - Plate evaporator: 3.3°C
 Brine anti-freeze threshold: Lower of the two cooling setpoints less 4.4°C
 Description: The evaporator leaving or entering water temperature is below the frost protection threshold.
 Action: The unit is stopped without pumping down.
 Reset: Automatic when leaving water temperature is 3.3°C above the control point and if the same fault has not occurred during the same day. Pumping down takes place on restarting. Manual reset if the fault has already occurred during the same day. Pumping down takes place on restarting.
 Probable cause: Low water flow rate or faulty thermistor.

Alarm 43 Low evaporator water flow
 Description: At least one compressor is running and the evaporator entering water temperature is 1.6°C or more lower than the evaporator leaving water temperature for at least 1 minute.
 Action: The circuit is stopped without pumping down.
 Reset: Manual. Pumping down takes place on restarting.
 Probable cause: Faulty control of pump or chilled water pump, or faulty thermistor.

NOTE

The evaporator entering water thermistor which is located in the evaporator shell reacts faster to the compressor operating conditions than the leaving water thermistor located in the water leaving pipe and can thus control the evaporator low water flow rate.

Alarm 44 Low suction temperature, circuit A
 Alarm 45 Low suction temperature, circuit B
 Description: The circuit is operating, and the saturated suction temperature is 16.6°C or more below the evaporator leaving water temperature at the anti-freeze threshold of 1.1°C for 10 minutes.
 Action: The circuit is stopped without pumping down.
 Reset: Manual. Pumping down takes place on restarting.
 Probable cause: Low refrigerant charge, blocked filter, faulty EXV or faulty thermistor.

NOTE

Alarms 44 or 45 are preceded by the following preventive phase: when the circuit is running and its saturated suction temperature is 13.3°C or more lower than the evaporator leaving water temperature and is below the defrost setpoint - 1.1°C for 5 minutes, then no slave compressor is authorised to start up on this circuit. Mode 14 is displayed. The circuit keeps running unless the suction low temperature alarm conditions described above are satisfied. See alarm 42 for a description of the defrost threshold values.

Alarm 46 High suction superheat, circuit A
 Alarm 47 High suction superheat, circuit B
 Description: On units fitted with EXV only. The EXV is fully open, suction superheat in the circuit is above 41.6°C and the saturated suction temperature is less than the MOP (Maximum Operating Pressure) for more than 5 minutes.
 If the circuit is fitted with a variable speed fan or condenser water valve, its speed/position must be zero or closed in addition to the criteria defined above.
 Action: The circuit is stopped with pumping down.
 Reset: Manual.
 Probable cause: Shortage of refrigerant, blocked filter, faulty EXV or thermistor.

Alarm 48 Low suction superheat, circuit A
 Alarm 49 Low suction superheat, circuit B
 Description: On units fitted with EXV only. The EXV is at its minimum position and either suction superheat in the circuit is below the superheat setpoint -5.5°C or the saturated suction temperature is greater than the MOP (Maximum Operating Pressure) for more than 5 minutes.
 If the circuit is fitted with a variable speed fan or condenser water valve, its speed or position must be maximum or fully open in addition to the criteria defined above.

Action: If the conditions described here are verified for the first time in a day, the circuit is stopped after pumping down and restarted. During the stop/restart period, mode 16 is displayed and alarms 48 and 49 are not activated.
If the conditions described above are verified a second time in the same day, alarms 48 and 49 are reported and the circuit is stopped with pumping down.

Reset: Manual.

Probable cause: Faulty EXV or thermistor or suction pressure sensor.

Alarm 50 Low oil pressure, compressor A1

Alarm 51 Low oil pressure, compressor B1

This alarm is not active during the minute following compressor start-up.

Description: The unit is fitted with oil pressure sensors on the lead compressors and the differential oil pressure is below the minimum oil pressure threshold for one minute.

Action: The circuit is stopped without pumping down.

Reset: Manual. Pumping down of the circuit takes place on restarting.

Probable cause: Faulty compressor, EXV, crankcase heater or pressure sensor; too much refrigerant or too little oil.

NOTE

The value of the minimum oil pressure threshold is configured in the factory.

Alarm 52 Low oil pressure, compressor A2

Alarm 53 Low oil pressure, compressor B2

Alarm 54 Low oil pressure, compressor A3

Alarm 55 Low oil pressure, compressor B3

Alarm 56 Low oil pressure, compressor A4

Alarm 57 Low oil pressure, compressor B4

This alarm is not active during the minute following compressor start-up.

Description: The compressor is fitted with an oil pressure sensor and the differential oil pressure is below the minimum oil pressure threshold for one minute.

Action: The compressor is stopped.

Reset: Manual.

Probable cause: Faulty compressor, EXV, crankcase heater or pressure sensor; too much refrigerant or too little oil.

NOTE

The value of the minimum oil pressure threshold is configured in the factory.

Alarm 58 Safety lockout control loop open

Description: The loop did not close before the end of the delay at start-up pause or opened in the course of operation.

Action: The compressors are not started or the unit is stopped without pumping down.

Reset: Manual. Pumping down takes place on restarting.

Alarm 59

Reclaim mode injection phase (changeover) fault, circuit A

Alarm 60

Reclaim mode injection phase (changeover) fault, circuit B

Description: The unit is fitted with the heat reclaim module option. An injection phase (changeover sequence) from normal to reclaim mode or vice-versa has been interrupted more than three times prior to completion.

Action: The circuit is stopped without pumping down.

Reset: Manual. Pumping down takes place on restarting, followed by the changeover sequence.

Probable cause: Three successive interruptions due to alarms, or due to a circuit halt caused by a drop in load or power supply interrupt.

Alarm 61

CCN emergency stop

Description: An emergency stop network command has been sent by the CCN.

Action: The unit is stopped without pumping down.

Reset: Automatic when CCN variable EMSTOP returns to a normal value. Pumping down takes place on restarting.

Alarm 62

See description in section 6.4.2

Alarm 63

Loss of communication with System Manager

Description: The unit is under the control of a System Manager (Flotronic System Manager or Chiller System Manager II) and communication is lost with this module for more than 2 minutes.

Action: The unit reverts to an autonomous operating mode.

Reset: Automatic when communication with the SM is re-established.

Alarm 64

Loss of communication with a slave unit

Description: The master/slave link is broken by loss of communication between these two units for more than 2 minutes.

Action: Each unit reverts to an autonomous operating mode.

Reset: Automatic when communication between the two units is re-established.

6.4.4 - Compressor faults

6.4.4.1 - General

Each compressor is protected against multiple faults by 4 digital inputs located on the control board. If one of these inputs opens, it causes an immediate shutdown on the compressor without any action from the basic board.

6.4.4.2 - Compressor protection devices

On PRO-DIALOG Plus units, compressors are individually protected by the following devices connected to the digital inputs on the compressor control board:

DGT (only for units equipped with low temperature option):

The discharge gas thermostat detects and protects the compressor against abnormally high discharge temperatures.

Starter Guard:

This board patented by Carrier (also called AM board) monitors both the compressor regime and the status of its crankcase heaters which ensure correct lubrication when the compressor starts.

GCP:

Ground current protection board (or leakage current protection). The detection of earth leakage currents protects the cooling circuit against possible contamination should the compressor motor develop a fault. This device is only used on circuits with several compressors and is connected only to the lead compressor control board.

HP:

High pressure switch. This is fitted only to lead compressors, but if this contact opens the whole circuit is shut down.

6.4.4.3 - Description of fault codes

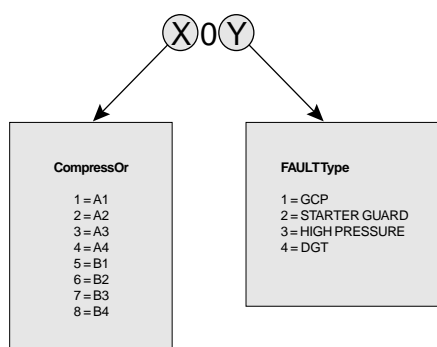

Compressor faults are identified by a 3-digit code.

Alarm x01

Description:

GCP fault

This fault affects lead compressors only: x = 1 or 5. Also it is only used on circuits with at least one slave compressor. The earth leakage protection contact is open (A.xD on wiring diagrams).

Action:

The circuit is stopped without pumping down.

Reset:

Manual. Pumping down takes place on restarting the circuit.

NOTE

The GCP board must be reinitialised manually (turn off the power supply).

Alarm x02

Description:

Starter Guard fault

The contact from the Starter Guard board (A.xM on wiring diagrams, where x = 1, 2, 3, 4, 5, 6, 7, 8) is open.

Action:

The circuit is stopped without pumping down if the faulty compressor is a leader (x = 1 or 5) otherwise only the slave compressor is stopped.

Reset:

Manual. Pumping down takes place on restarting if the circuit has been stopped.

NOTE

The AM board must be reinitialised manually (turn off the power supply).

Alarm x03

Description:

High pressure fault

This fault affects lead compressors only: x = 1 or 5. The contact from the high pressure switch is open.

Action:

The circuit is stopped without pumping down.

Reset:

Manual. Pumping down takes place on restarting the circuit.

NOTE

The HP contact must be reset manually with the pushbutton located on or in the pressure switch.

Alarm x04

Description:

DGT (discharge gas thermostat) fault (only for units equipped with low temperature option)

The contact from the discharge gas thermostat is open.

Action:

The circuit is stopped without pumping down if the faulty compressor is a leader (x = 1 or 5) otherwise only the slave compressor is stopped.

Reset:

Manual. Pumping down takes place on restarting if the circuit has been stopped.

NOTE

The discharge gas thermostat is reset automatically.



Order No. 13163-76, 05 1998 - Supersedes order No.: 09 1996
Manufacturer reserves the right to change any product specifications without notice.



Environmental Management System Approval

Printed in the Netherlands on totally chlorine-free paper.
Manufactured by: Carrier S.A., Montluel, France.