

AJYA72LALH
AJYA90LALH
AJY108LALH
AJY126LALH
AJY144LALH

AJHA72LALH
AJHA90LALH
AJH108LALH
AJH126LALH
AJH144LALH

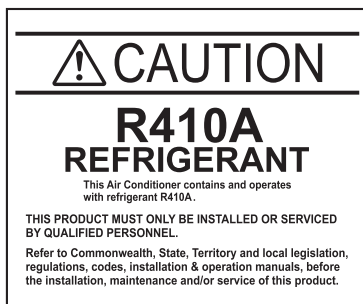

FUJITSU GENERAL LIMITED

INSTALLATION MANUAL

OUTDOOR UNIT

For authorized service personnel only.

English

INSTALLATIONSANLEITUNG

AUßENGERÄT

Nur für autorisiertes Fachpersonal.

Deutsch

MANUEL D'INSTALLATION

UNITÉ EXTÉRIEURE

Pour le personnel agréé uniquement.

Français

MANUAL DE INSTALACIÓN

UNIDAD EXTERIOR

Únicamente para personal de servicio autorizado.

Español

MANUALE DI INSTALLAZIONE

UNITÀ ESTERNA

A uso esclusivo del personale tecnico autorizzato.

Italiano

ΕΓΧΕΙΡΙΔΙΟ ΕΓΚΑΤΑΣΤΑΣΗΣ

ΕΞΩΤΕΡΙΚΉ ΜΟΝΑΔΑ

Μόνο για εξουσιοδοτημένο τεχνικό προσωπικό.

Ελληνικά

MANUAL DE INSTALAÇÃO

UNIDADE EXTERIOR

Apenas para técnicos autorizados.

Português

РУКОВОДСТВО ПО УСТАНОВКЕ

ВНЕШНИЙ МОДУЛЬ

Только для авторизованного обслуживающего персонала.

Русский

MONTAJ KILAVUZU

DIŞ ÜNİTE

Yalnızca yetkili servis personeli için.

Türkçe

安装说明书

室外机

仅针对授权的专业维修人员。

中文

PART NO. 9378945104

INSTALLATION MANUAL

PART NO. 9378945104
VRF system outdoor unit

CONTENTS

| | |
|--|----|
| 1. SAFETY PRECAUTIONS | 1 |
| 2. ABOUT THE UNIT | 2 |
| 2. 1. Precautions for using the R410A refrigerant | 2 |
| 2. 2. Special tools for R410A | 2 |
| 2. 3. Accessories | 2 |
| 2. 4. Combinations | 2 |
| 2. 5. Optional parts | 3 |
| 3. INSTALLATION WORK | 3 |
| 3. 1. Selecting an installation location | 3 |
| 3. 2. Drain processing | 3 |
| 3. 3. Installation dimensions | 3 |
| 3. 4. Transportation the outdoor unit | 5 |
| 3. 5. Installation the unit | 6 |
| 4. SYSTEM CONFIGURATION | 6 |
| 4. 1. System configuration | 6 |
| 4. 2. Pipe selection | 7 |
| 4. 3. Protection of pipes | 8 |
| 5. PIPE INSTALLATION | 8 |
| 5. 1. Brazing | 8 |
| 5. 2. Indoor unit pipe connections | 8 |
| 5. 3. Piping method | 8 |
| 5. 4. Multiple connections | 9 |
| 6. ELECTRICAL WIRING | 11 |
| 6. 1. The precautions of electrical wiring | 11 |
| 6. 2. Wiring method | 11 |
| 6. 3. Knockout hole | 11 |
| 6. 4. Selecting power supply cable and breaker | 12 |
| 6. 5. Transmission line | 12 |
| 6. 6. Wiring procedure | 13 |
| 6. 7. External input and external output | 14 |
| 7. FIELD SETTING | 15 |
| 7. 1. Field setting switches | 15 |
| 7. 2. DIP switch setting | 15 |
| 7. 3. Rotary switch setting | 16 |
| 7. 4. Push button setting | 17 |
| 7. 5. Signal amplifier address setting | 19 |
| 7. 6. Indoor unit address setting | 19 |
| 7. 7. Resistance measurement of transmission cable (Measure with breaker OFF) | 20 |
| 8. PIPE INSTALLATION II | 20 |
| 8. 1. Sealing test | 20 |
| 8. 2. Vacuum process | 20 |
| 8. 3. Additional charging | 21 |
| 8. 4. Installing insulation | 22 |
| 9. TEST RUN | 22 |
| 9. 1. Pre-test run check items | 22 |
| 9. 2. Test operation method | 22 |
| 9. 3. Checklist | 23 |
| 10. LED Status | 23 |
| 10. 1. Normal operation mode | 23 |
| 10. 2. Error codes | 23 |
| 11. INFORMATION | 24 |

| |
|---|
| To install a unit that uses the R410A refrigerant, use dedicated tools and piping materials that have been manufactured specifically for R410A use. Because the pressure of the R410A refrigerant is approximately 1.6 times higher than the R22, failure to use dedicated piping material or improper installation can cause rupture or injury. It will also cause serious accidents such as refrigerant leakage, water leakage, electric shock, and fire. |
| Do not use this equipment with air or any other unspecified refrigerant in the refrigerant lines. Excess pressure can cause a rupture. |
| Be sure to install the unit as prescribed, so that it can withstand earthquakes and typhoons or other strong winds. Improper installation can cause the unit to topple or fall, or other accidents. |
| Ensure that the outdoor unit is securely installed at a place that can withstand the weight of the unit. Improper installation will cause injuries caused by falling unit. |
| If there is a refrigerant leakage, make sure that it does not exceed the concentration limit. If a refrigerant leakage exceeds the concentration limit, it can lead to accidents such as oxygen starvation. |
| If a refrigerant leakage occurs during operation, immediately vacate the premises and thoroughly ventilate the area. If the refrigerant is exposed to fire, it will create a hazardous gas. |
| Electrical work must be performed in accordance with this Installation manual by a person certified under the national or regional regulations. Be sure to use a dedicated circuit for the unit. An insufficient power supply circuit or improperly performed electrical work can cause serious accidents such as electric shock or fire. |
| For wiring, use the prescribed type of cables, connect them securely, making sure that there are no external forces of the cables applied to the terminal connections. Improperly connected or secured cables can cause serious accidents such as overheating the terminals, electric shock, or fire. |
| Do not turn ON the power until all work has been completed. Turning ON the power before the work is completed can cause serious accidents such as electric shock or fire. |
| After the installation, make sure there is no refrigerant leakage. If the refrigerant leaks into the room and becomes exposed to a source of fire such as a fan heater, stove, or burner, it will create a hazardous gas. |
| Use a wall hole pipe. Otherwise, it may cause a short circuit. |
| Do not place the outdoor unit near the handrail of the balcony. Children may climb onto the outdoor unit, lean over the handrail and fall over. |
| Use only a specified power cable. Poor connection, poor insulation, and exceeding the allowable current will lead to electric shock and fire. |
| Attach the connecting cables securely to the terminal. Or secure it firmly with a "wiring suppressor". Loose connection will lead to malfunction, electric shock, and fire. |
| Install a breaker to cut off all AC main current at the same time. If you do not install a breaker, it may cause electric shock and fire. |
| During installation, make sure that the refrigerant pipe is attached firmly before you run the compressor. Do not operate the compressor under the condition of refrigerant piping not attached properly with 2-way or 3-way valve open. This may cause abnormal pressure in the refrigeration cycle that leads to rupture and even injury. |
| During the pump-down operation, make sure that the compressor is turned off before you remove the refrigerant piping. Do not remove the connection pipe while the compressor is in operation with 2-way or 3-way valve open. This may cause abnormal pressure in the refrigeration cycle that leads to breakage and even injury. |
| If there is a possibility of touching the fan during maintenance, make sure to turn OFF the power before implementing the maintenance. Even if operations are suspended, the fan of outdoor unit sometimes rotates, so if the fan rotates suddenly while in contact with you may cause serious injury. |

| | |
|---|---|
| CAUTION | This mark indicates procedures which, if improperly performed, might possibly result in personal harm to the user, or damage to property. |
| This unit must be installed by qualified personnel with a capacity certificate for handling refrigerant fluids. Refer to regulation and laws in use on installation place. | |
| The installation must be carried out in compliance with regulations in force in the place of installation and the installation instructions of the manufacturer. | |
| This unit is part of a set constituting an air conditioner. It must not be installed alone or with non-authorized by the manufacturer. | |
| This unit contains no user-serviceable parts. Always consult authorized service personnel to repairs. | |
| When moving, consult authorized service personnel for disconnection and installation of the unit. | |
| <ul style="list-style-type: none"> Obtain the distribution network operator's agreement about the power capacity of the power supply system, specification of the cable and the harmonic current, and etc. when you connect the outdoor unit with the power supply. This unit must be connected to a power supply with impedance of 0.33 ohm and below. If the power supply does not satisfy this requirement, please consult the power supplier. This product is intended for professional use. Be sure to use a dedicated power circuit. Never use a power supply shared by another appliance. | |

1. SAFETY PRECAUTIONS

- Be sure to read this Installation manual thoroughly before installation.
- The warnings and precautions indicated in this Installation manual contain important information pertaining to your safety. Be sure to observe them.
- After installing the unit, perform a test run to make sure the unit operates normally. Then, explain to the customer how to operate and maintain the unit.
- Please pass this Installation manual together with the Operating manual to the customer. Please ask the customer to keep the Operating manual and Installation manual at hand for future reference during the moving or repair of the main unit.

| | |
|--|---|
| WARNING | This mark indicates procedures which, if improperly performed, might lead to the death or serious injury of the user. |
| For installation purposes, be sure to use the parts supplied by the manufacturer or other prescribed parts. Using non-specified parts will cause serious accidents such as falling unit, refrigerant leakage, water leakage, electric shock, and fire. | |

Do not install the unit in the following areas:

- Area with high salt content, such as at the seaside. It will deteriorate metal parts, causing the parts to fall or the unit to leak water.
- Area filled with mineral oil or containing a large amount of splashed oil or steam, such as a kitchen. It will deteriorate plastic parts, causing the parts to fall or the unit to leak water.
- Area that generates substances that adversely affect the equipment, such as sulfuric gas, chlorine gas, acid, or alkali. It will cause the copper pipes and brazed joints to corrode, which can cause refrigerant leakage.
- Area containing equipment that generates electromagnetic interference. It will cause the control system to malfunction, preventing the unit from operating normally.
- Area that can cause combustible gas to leak, contains suspended carbon fibers or flammable dust, or volatile inflammables such as paint thinner or gasoline. If gas leaks and settles around the unit, it can cause a fire.
- Avoid installing the unit at places where it will come into contact with animals' urine or ammonia.

The units are not explosion proof and therefore should not be installed in explosive atmosphere.

Do not use the unit for special purposes, such as storing food, raising animals, growing plants, or preserving precision devices or art objects. It can degrade the quality of the preserved or stored objects.

Ground the unit. Do not connect the ground wire to a gas pipe, water pipe, lightning rod, or a telephone ground wire. Improper grounding may cause electric shock.

Perform draining for the unit according to the Installation manual. Check that the water is properly drained. If the drain processing is improperly installed, water may drip down from the unit, wetting the furniture.

Do not touch the fins with bare hands.

Be sure not to start or stop the operation of air conditioning with power breaker. Otherwise, it may cause malfunction or water leakage.

When setting it up near the equipment that generates electromagnetic waves and the equipment that generates the higher harmonics wave, be sure to take measures against noise. Otherwise, it may cause malfunction or failure.

When energizing to the crankcase heater, please turn on the power 12 hours or earlier before operation begins. When the energizing time is short, it may cause failure. Besides, please do not turn off power during the busy season.

Children should be monitored to ensure they do not play with the device.

This product is not intended to be used by people (including children) with physical, sensory or mental disability, or persons lacking experience or knowledge unless they have been given by the through a person responsible for their safety, supervision or instruction concerning the use of the device.

2. ABOUT THE UNIT

2.1. Precautions for using the R410A refrigerant

Pay careful attention to the following points :

Since the working pressure is 1.6 times higher than that of R22 models, some of the piping and installation and service tools are special. (See the table in the SPECIAL TOOLS FOR R410A section.)

Especially, when replacing a conventional refrigerant (other than R410A) model with a new refrigerant R410A model, always replace the conventional piping and flare nuts with the R410A piping and flare nuts.

Models that use refrigerant R410A have a different charging port thread diameter to prevent erroneous charging with R22, R407C and for safety. Therefore, check beforehand. [The charging port thread diameter for R410A is 1/2 UNF 20 threads per inch.]

Be more careful than the installation of the refrigerant (other than R410A) models, not to enter foreign matters (oil, water, etc.) and other refrigerant into the piping. Also, when storing the piping, securely seal the openings by pinching, taping, etc.

When charging the refrigerant, take into account the slight change in the composition of the gas and liquid phases, and always charge from the liquid phase side whose composition is stable.





2.2. Special tools for R410A

| Tool name | Contents of change for R22 tool |
|----------------|--|
| Gauge manifold | Pressure is huge and cannot be measured with a conventional (R22) gauge. To prevent erroneous mixing of other refrigerants, the diameter of each port has been changed. It is recommended to use a gauge manifold with a high pressure display range -0.1 to 5.3 MPa and a low pressure display range -0.1 to 3.8 MPa. |
| Charging hose | To increase pressure resistance, the hose material and base size were changed. |

| Tool name | Contents of change for R22 tool |
|----------------------|---|
| Vacuum pump | A conventional (R22) vacuum pump can be used by installing a vacuum pump adapter. <ul style="list-style-type: none"> • A conventional vacuum pump can be used by installing a vacuum pump adapter. • Be sure that the pump oil does not back flow into the system. Use one capable for vacuum suction of -100.7kPa (5 Ton, -755mmHg). |
| Gas leakage detector | Special gas leakage detector for HFC refrigerant R410A. |

2.3. Accessories

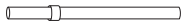
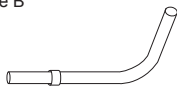
Use connecting parts as required. Do not throw away the connecting parts until the installation has been complete.

| Name and shape | Q'ty | Application |
|---|------|--|
| Specifications manual  | 1 | — |
| Installation manual  | 1 | (This book) |
| Joint pipe A  | 1 | For connecting gas pipe (Straight type) |
| Joint pipe B  | 1 | For connecting gas pipe (L type) |
| Cable tie  | 4 | For binding power cable and transmission cable |

2.4. Combinations

A maximum of 3 outdoor units can be connected to 1 refrigerant system. The combination of outdoor units per refrigerant system and the number of indoor units that can be connected are as follows:

| Outdoor Unit | |
|--------------|------------------------------|
| Model Name | Nominal System Capacity (HP) |
| AJ□A72LALH | 8 |
| AJ□A90LALH | 10 |
| AJ□108LALH | 12 |
| AJ□126LALH | 14 |
| AJ□144LALH | 16 |

| Installation space combination | | | | | | | | | | | | |
|---------------------------------|----|----|----|----|----|----|----|----|----|----|----|--|
| Combination (HP) | 8 | 10 | 12 | 14 | 16 | 18 | 20 | 22 | 24 | 26 | 28 | |
| Outdoor Unit 1 (HP) | 8 | 10 | 12 | 14 | 16 | 10 | 12 | 12 | 12 | 14 | 16 | |
| Outdoor Unit 2 (HP) | — | — | — | — | — | 8 | 8 | 10 | 12 | 12 | 12 | |
| Outdoor Unit 3 (HP) | — | — | — | — | — | — | — | — | — | — | — | |
| Maximum Connectable Indoor Unit | 15 | 16 | 17 | 21 | 24 | 32 | 32 | 32 | 35 | 39 | 42 | |
| Combination (HP) | 30 | 32 | 34 | 36 | 38 | 40 | 42 | 44 | 46 | 48 | | |
| Outdoor Unit 1 (HP) | 16 | 16 | 12 | 12 | 14 | 16 | 16 | 16 | 16 | 16 | | |
| Outdoor Unit 2 (HP) | 14 | 16 | 12 | 12 | 12 | 12 | 14 | 16 | 16 | 16 | | |
| Outdoor Unit 3 (HP) | — | — | 10 | 12 | 12 | 12 | 12 | 12 | 14 | 16 | | |
| Maximum Connectable Indoor Unit | 45 | 48 | 48 | 48 | 48 | 48 | 48 | 48 | 48 | 48 | | |

When connecting outdoor units, install the outdoor unit with the largest nominal system capacity nearest to the refrigerant pipe and indoor unit, followed by those with lesser nominal system capacities. (Outdoor unit 1 ≥ Outdoor unit 2 ≥ Outdoor unit 3)

Energy-saving combination

| Combination (HP) | 8 | 10 | 12 | 14 | 16 | 18 | 20 | 22 | 24 | 26 | 28 |
|---------------------------------|---|----|----|----|----|----|----|----|----|----|----|
| Outdoor Unit 1 (HP) | - | - | - | - | 8 | - | - | 14 | 8 | 10 | 12 |
| Outdoor Unit 2 (HP) | - | - | - | - | 8 | - | - | 8 | 8 | 8 | 8 |
| Outdoor Unit 3 (HP) | - | - | - | - | - | - | - | - | 8 | 8 | 8 |
| Maximum Connectable Indoor Unit | * | * | * | * | 30 | * | * | 33 | 36 | 39 | 42 |

| Combination (HP) | 30 | 32 | 34 | 36 | 38 | 40 | 42 | 44 | 46 | 48 |
|---------------------------------|----|----|----|----|----|----|----|----|----|----|
| Outdoor Unit 1 (HP) | 14 | 12 | 14 | 14 | - | 14 | 14 | 16 | - | - |
| Outdoor Unit 2 (HP) | 8 | 12 | 12 | 14 | - | 14 | 14 | 14 | - | - |
| Outdoor Unit 3 (HP) | 8 | 8 | 8 | 8 | - | 12 | 14 | 14 | - | - |
| Maximum Connectable Indoor Unit | 45 | 48 | 48 | 48 | * | 48 | 48 | 48 | * | * |

* Means that the energy-saving combination is unavailable.
When connecting outdoor units, install the outdoor unit with the largest nominal system capacity nearest to the refrigerant pipe and indoor unit, followed by those with lesser nominal system capacities. (Outdoor unit 1 ≥ Outdoor unit 2 ≥ Outdoor unit 3)

2.5. Optional parts

⚠ CAUTION

The following parts are optional parts specific to R410A refrigerant.
Do not use parts other than those listed below.

2.5.1. Outdoor unit branch kit

| Model | Total cooling capacity of indoor unit (kW) |
|------------------------|--|
| UTP-CX567A, UTR-CP567X | ALL |

2.5.2. Separation tube

| Model | Total cooling capacity of indoor unit (kW) |
|------------------------|--|
| UTP-AX090A, UTR-BP090X | 28.0 or less |
| UTP-AX180A, UTR-BP180X | 28.1 to 56.0 |
| UTP-AX567A, UTR-BP567X | 56.1 or more |

2.5.3. Header

| 3-6 branches | 3-8 branches | Total cooling capacity of indoor unit (kW) |
|--------------|--------------|--|
| UTR-H0906L | UTR-H0908L | 28.0 or less |
| UTR-H1806L | UTR-H1808L | 28.1 to 56.0 |

3. INSTALLATION WORK

Please obtain the approval of the customer when selecting the location of installation and installing the main unit.

3.1. Selecting an installation location

⚠ WARNING

Install the unit in a location that can withstand its weight, and where it will not topple or fall.

Calculate the proper refrigerant concentration if you will be installing it in an enclosed location.

$$\frac{\text{Total amount of replenished refrigerant in refrigerant facility (kg)}}{\text{Capacity of smallest room where unit is installed (m}^3\text{)}} \leq \text{Refrigerant concentration (kg/m}^3\text{)} \leq (0.3\text{kg/m}^3)$$

If the results of the calculation exceed the concentration limit, increase the room surface area or install a ventilation duct.

⚠ CAUTION

Select an installation location by observing the following precautions:

Install the unit level. (Within 3 degrees)

Install this unit in a location with good ventilation.

If the unit must be installed in an area within easy reach of the general public, install as necessary a protective fence or the like to prevent their access.

Install the unit in an area that would not inconvenience your neighbors, as they could be affected by the airflow coming out from the outlet, noise, or vibration.
If it must be installed in proximity to your neighbors, be sure to obtain their approval.

If the unit is installed in a cold region that is affected by snow accumulation, snow fall, or freezing, take appropriate measures to protect it from those elements.
To ensure a stable operation, install inlet and outlet ducts.

Install the unit in an area that would not cause problems even if the drain water is discharged from the unit. Otherwise, provide drainage that would not affect people or objects.

⚠ CAUTION

Install the unit in an area that has no heat sources, vapors, or the risk of the leakage of flammable gas in the vicinity.

Install the unit in an area that is away from the exhaust or vent ports that discharge vapor, soot, dust, or debris.

Install the indoor unit, outdoor unit, power supply cable, transmission cable and remote control cable at least 1 meter away from a television or radio.
The purpose of this is to prevent TV reception interference or radio noise. (Even if they are installed more than 1 meter apart, you could still receive noise under some signal conditions.)

Keep the length of the piping of the indoor and outdoor units within the allowable range.

For maintenance purposes, do not bury the piping.

3.2. Drain processing

- The drain water is discharged from the bottom of the equipment. Construct a drain ditch around the base and discharge the drain water properly.
- When installing on a roof, perform floor waterproofing properly.

Drain processing:

- The drain water from the base of the outdoor unit may generate during operations. Perform drain processing, as necessary.
- When you want to prevent the drain water from leaking at the perimeter, construct a ditch for the drain water as shown in the figure.
- Provide a central drain pan, as necessary.

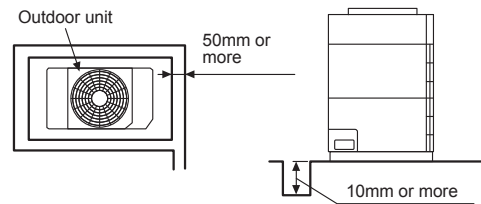

3.3. Installation dimensions

⚠ CAUTION

When installing the outdoor unit, pay attention to the following items.

Provide sufficient installation space, such as transportation route, maintenance space, ventilation space, refrigerant piping space, and passageways.

Pay attention to the specifications of the installation space as shown in the figure. If the unit is not installed according to specifications, it may cause short circuit or poor performance. The unit may be prone to lapse into non-operation due to high pressure protection.

Do not place obstructions in the air flow outlet direction. If there is an obstruction in the outlet direction, install an outlet duct.

When there is a wall in front of the unit, provide a space of 500mm or more as maintenance space.

When there is a wall at the left side of the unit, provide a space of 30mm or more as maintenance space.

An outdoor temperature of 35 degrees in air-conditioned operation is assumed for the installation space in this item. If the outdoor temperature exceeds 35 degrees and the outdoor unit is operating at a load exceeding its rated ability, provide a larger inlet space.

If you are installing more outdoor units than indicated here, please ensure sufficient space or consult your distributing agent as it may affect the performance due to short circuit and other problems.

3.3.1. When install near by limited height wall

(1) Single and multiple installations

- There are no restrictions on the height of the side wall.
- Provide installation spaces L1 and L2 in accordance with the table below according to the wall height (front side, rear side) conditions.
- Provide installation spaces other than L1 and L2 in accordance with the conditions shown in the figure below.
- Ventilation resistance can be ignorable when the distance from a wall or product, etc. is larger than 2m.

| Wall height condition | Necessary installation space |
|------------------------------|------------------------------|
| When H1 is 1500 (mm) or less | L1 ≥ 500 (mm) |
| When H1 is 1500 (mm) or more | L1 ≥ 500+h1+2 (mm) |
| When H2 is 500 (mm) or less | L2 ≥ 100 (mm) |
| When H2 is 500 (mm) or more | L2 ≥ 100+h2+2 (mm) |

Fig. 1

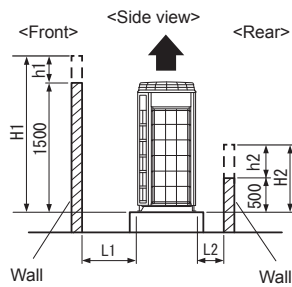

Fig. 2 Single installation

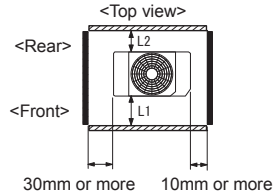
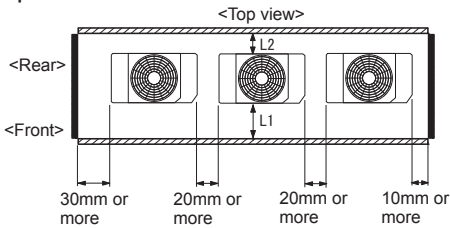

Fig. 3 Multiple installations



(2) Concentrated installation

- Provide installation spaces L3, L4, and L5 in accordance with the table below according to the wall height (front side, rear side) conditions.
- Provide installation spaces other than L3, L4, and L5 in accordance with the conditions shown in the figure below.
- Ventilation resistance can be ignorable when the distance from a wall or product, etc. is larger than 2m.

| Wall height condition | Necessary installation space |
|------------------------------|------------------------------|
| When H3 is 1500 (mm) or less | $L3 \geq 500$ (mm) |
| When H3 is 1500 (mm) or more | $L3 \geq 500+h3+2$ (mm) |
| When H4 is 500 (mm) or less | $L4 \geq 200$ (mm) |
| When H4 is 500 (mm) or more | $L4 \geq 200+h4+2$ (mm) |
| When H5 is 500 (mm) or less | $L5 \geq 200$ (mm) |
| When H5 is 500 (mm) or more | $L5 \geq 200+h5+2$ (mm) |

Fig. 4

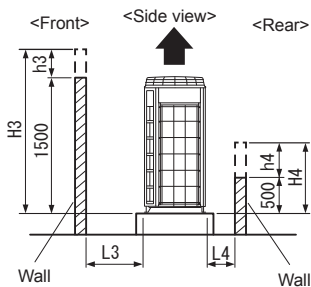

Fig. 5

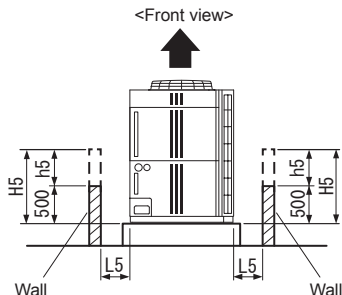

Fig. 6

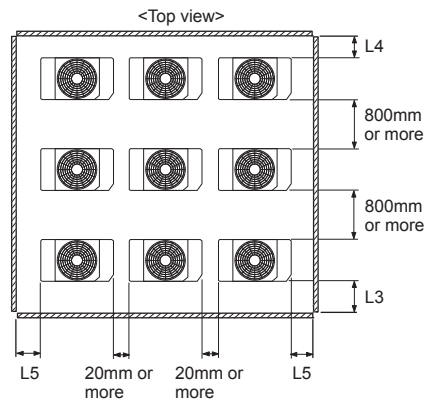
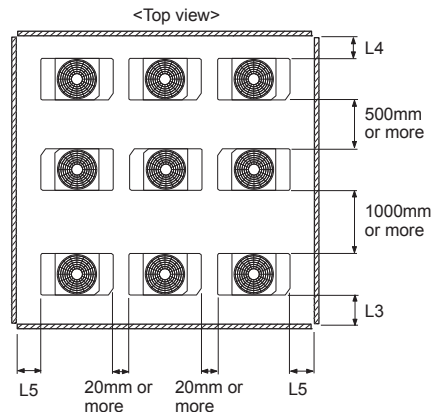

Fig. 7



3. 3. 2. When install near unlimited height wall

(1) Single and multiple installations

- There are no restrictions on the height of the wall.
- The wall (without height restrictions) must not exist on the both sides (left / right) of outdoor unit. Also, must not exist on the both sides (front / rear) of outdoor unit.
- Provide installation spaces other than L6 in accordance with the conditions shown in the figure below.
- Ventilation resistance can be ignorable when the distance from a wall or product, etc. is larger than 2 m.

When installing with the REAR of the outdoor unit facing the wall side

| Condition | Necessary installation space |
|-----------------------------|---------------------------------------|
| When $B \geq 400$ (mm) | $L6 \geq 200$ (mm) |
| When $20 \leq B < 400$ (mm) | $L6 \geq 200 + (400-B) \times 3$ (mm) |

Fig. 8 Single installation

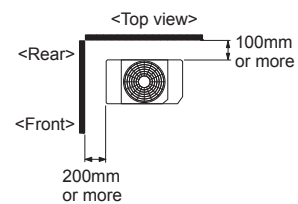
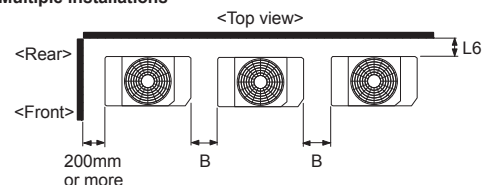
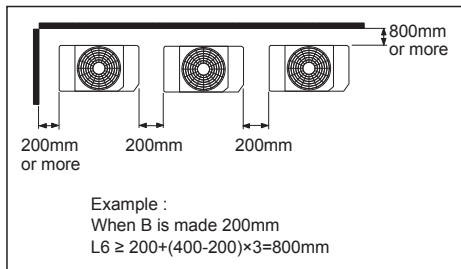

Fig. 9 Multiple installations





When installing with the FRONT of the outdoor unit facing the wall side
Fig. 10

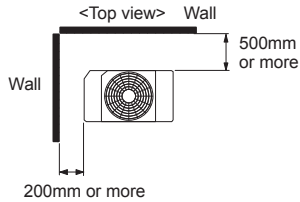
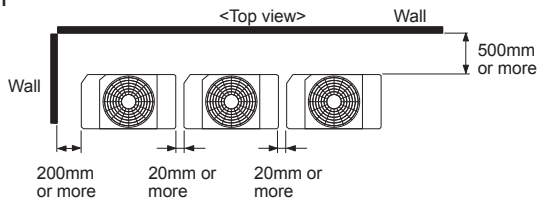

Fig. 11



(2) Concentrated Installation

- The wall (without height restrictions) must not exist on the both sides (left / right) of outdoor unit. Also, must not exist on the both sides (front / rear) of outdoor unit.
- Ventilation resistance can be ignorable when the distance from a wall or product, etc. is larger than 2m.

Fig. 12

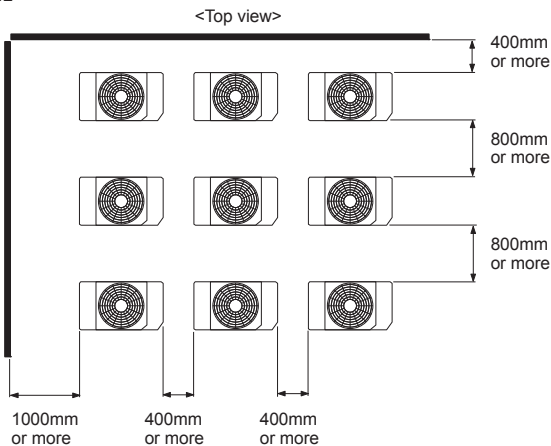
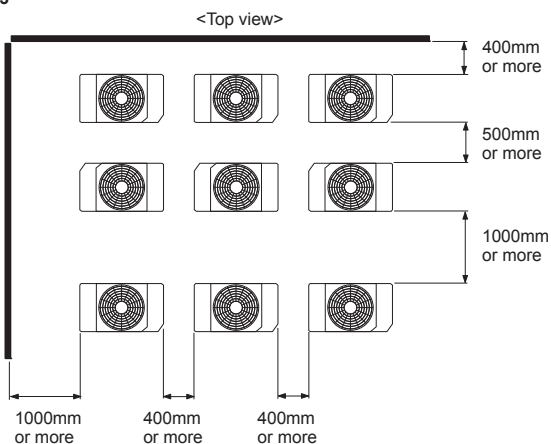

Fig. 13



3. 3. 3. When there are obstacles above the product

When there are obstacles above the product, keep the minimum installation height as shown in the figure and install the outlet duct.

When installing the outlet duct, you must set the high static pressure mode with the push-button switch. (Similar when installing anti-snow hood)

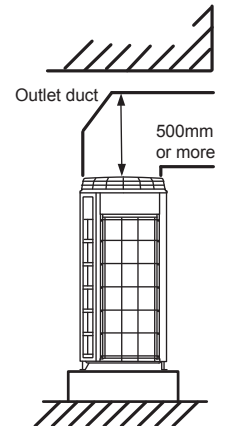

Setting high static pressure mode

Follow the instructions in the table below to set the high static pressure mode.

| Condition | High static pressure mode setting ^{*2} |
|--|---|
| Static Pressure (SP) ^{*1} : $0 \leq SP \leq 30$ (Pa) | Set to Mode 1 |
| Static Pressure (SP) ^{*1} : $30 < SP \leq 80$ (Pa) | Set to Mode 2 |

*1. Static pressure is the air flow resistance that includes the discharge duct resistance & the other additional resistance like discharge grill and so on.

*2. Refer to the section on Push Switch Setting in "Chapter 7 Field Setting".

3. 4. Transportation the outdoor unit

| Product mass (kg) | |
|-------------------|-----|
| AJ□A72LALH | 220 |
| AJ□A90LALH | 220 |
| AJ□108LALH | 275 |
| AJ□126LALH | 303 |
| AJ□144LALH | 303 |

Hoisting method

- When hanging the outdoor unit and conveying it to installation location, hang the unit with rope by passing through the 4 opening holes on bottom of front and rear side as shown in figure.
- Use 2 ropes at least 8m long. If used shorter length, it may cause to damage to the unit.
- Use the sufficiently strong rope to bear the unit's weight.
- Place the protective board or filler cloth at the place where the cabinet may come into contact with rope to prevent from damages. Without using them, cabinet may cause to damage or deform.
- During the hanging unit, make sure to keep the unit level to prevent from falling.
- To prevent an unit swing accident or falling down of the unit, do not apply any impact to the unit when it is hanging.

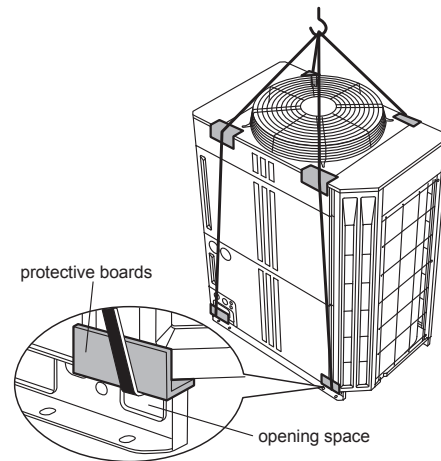

Lifting by forklift

- When using the forklift to lift the unit, pass the forklift arms through the opening space as shown in below.
Front : Bottom of the wooden delivery pallet.
Side : Space between pallet and cabinet.
(Enable to remove the pallet from cabinet.)
- Be careful not to be damaged.

Lifting by forklift (Manual forklift: hand-fork)

- When using the manual forklift to lift the unit, pass the forklift arms through to the opening space between pallet and cabinet from side.

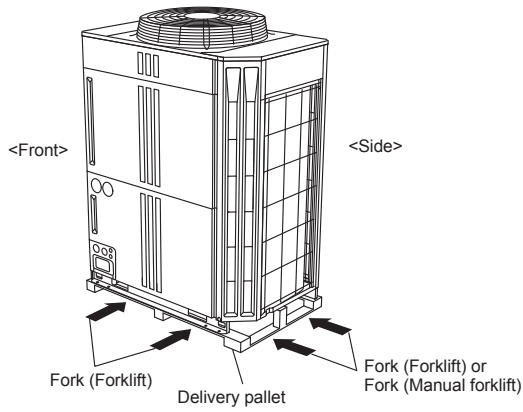

3.5. Installation the unit

- Install the unit level. (within 3 degrees).
- Install 4 or more anchor bolts at the 8 locations indicated by arrows (Fig. A).
- Place the left and right anchor bolts at a distance further away than the dimensions of A in the Table A.
(Excluding the case where anchor bolts are installed at 8 places.)

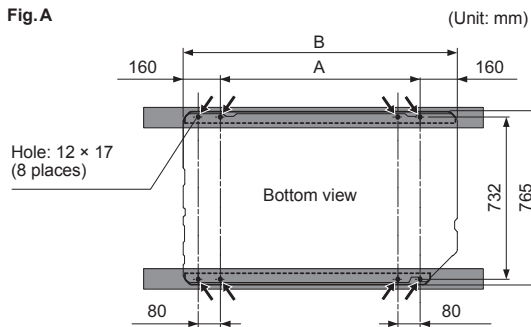
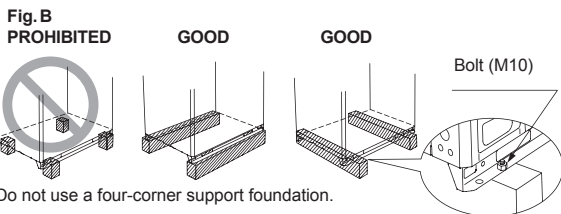

Table.A

| Model name | A | B |
|------------|-----|------|
| AJ□A72LALH | 610 | 930 |
| AJ□A90LALH | 610 | 930 |
| AJ□108LALH | 610 | 930 |
| AJ□126LALH | 920 | 1240 |
| AJ□144LALH | 920 | 1240 |

- To minimize vibration, do not install the outdoor unit directly on the ground. Instead, install it on top of a firm platform (such as concrete block). (Fig. B)
- The foundation base should be able to support the product and the foot width of the product should be more than 46.5mm.
- Depending on the installation condition, vibration during the operation of the unit may cause noise and vibration. Install vibration-proofing materials (such as rubber pads).
- Consider the removal space of the connection piping when installing the foundation.
- Secure the equipment firmly with anchor bolts, washers, and nuts.



*Do not use a four-corner support foundation.

Fig. C

When installing piping from the bottom of the outdoor units, the required space under the outdoor unit $\geq 200\text{mm}$.
*Install the branch kit horizontally.

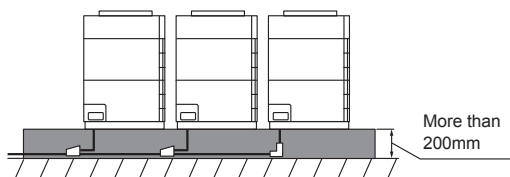

4. SYSTEM CONFIGURATION

4.1. System configuration

⚠ CAUTION

- When connecting multiple outdoor units, set the nearest outdoor unit to the indoor unit on the refrigerant pipe as the master unit.
- When connecting multiple outdoor units, install the outdoor unit with the largest nominal system capacity nearest to the indoor unit on the refrigerant pipe, followed by those with less nominal system capacities.
[Capacity: Master \geq Slave]
- Always keep to the limit on the total amount of refrigerant. Exceeding the limit on the total amount of refrigerant when charging will lead to malfunction.

A) In case of 1 outdoor unit connected

Fig. A

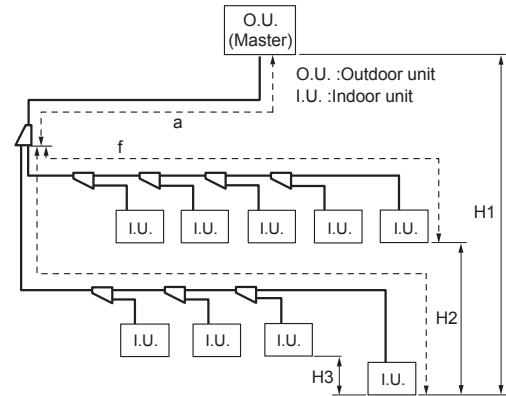

- Allowable pip length (actual pipe length)

| | | |
|--|---------------|------------|
| Between master outdoor unit and the farthest indoor unit | 150 m or less | a+f a+p |
| Between the first separation tube and the farthest indoor unit | 60 m or less | f, p |
| Total pipe length | 700 m or less | Total |

- Allowable height difference

| | | |
|---|--------------|--------|
| Between outdoor unit and indoor unit (When indoor unit is installed below) | 50 m or less | H1 |
| Between outdoor unit and indoor unit (When outdoor unit is installed below) | 40 m or less | |
| Between indoor units | 15 m or less | H2, H3 |

- Total refrigerant amount : 31.5 kg or less

B) In case of 2 outdoor units connected

Fig. B

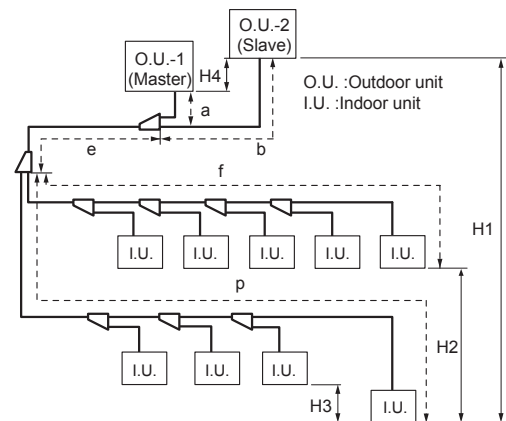

- Allowable pip length (actual pipe length)

| | | |
|--|----------------|----------------|
| Between master outdoor unit and the farthest indoor unit | 150 m or less | a+e+f a+e+p |
| Between the first separation tube and the farthest indoor unit | 60 m or less | f, p |
| Total pipe length | 1000 m or less | Total |
| Between outdoor unit and outdoor unit branch kit | 3 m or less | a, b |

- Allowable height difference

| | | |
|---|---------------|--------|
| Between outdoor unit and indoor unit (When indoor unit is installed below) | 50 m or less | H1 |
| Between outdoor unit and indoor unit (When outdoor unit is installed below) | 40 m or less | |
| Between indoor units | 15 m or less | H2, H3 |
| Between outdoor units | 0.5 m or less | H4 |

- Total refrigerant amount : 63 kg or less
- Outdoor unit capacity : Master ≥ Slave

C) In the case of 3 outdoor units connected

Fig. C

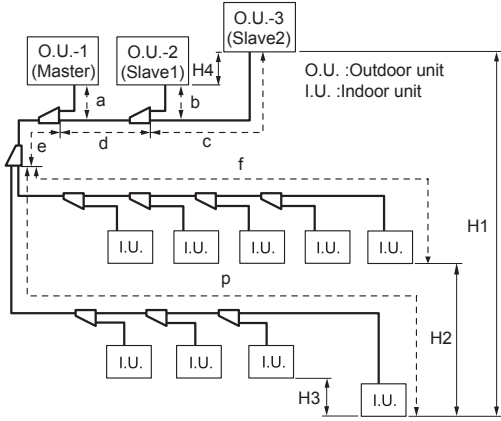

- Allowable pip length (actual pipe length)

| | | |
|---|----------------|----------------|
| Between master outdoor unit and the farthest indoor unit | 150 m or less | a+e+f a+e+p |
| Between the first separation tube and the farthest indoor unit | 60 m or less | f, p |
| Total pipe length | 1000 m or less | Total |
| Between outdoor unit and outdoor unit branch kit | 3 m or less | a, b, c |
| Between the farthest outdoor unit and the first outdoor unit branch kit | 12 m or less | b+d c+d |

- Allowable height difference

| | | |
|---|---------------|--------|
| Between outdoor unit and indoor unit (When indoor unit is installed below) | 50 m or less | H1 |
| Between outdoor unit and indoor unit (When outdoor unit is installed below) | 40 m or less | |
| Between indoor units | 15 m or less | H2, H3 |
| Between outdoor units | 0.5 m or less | H4 |

- Total refrigerant amount : 94.5 kg or less
- Outdoor unit capacity : Master ≥ Slave 1 ≥ Slave 2

NOTE) • If the outdoor temperature during cooling operation is expected to be -5 °C or less, do not install the outdoor unit lower than the indoor unit.
• Please refer to "8.3.2. Checking total amount of refrigerant and calculating the amount of refrigerant charge to be added" for the total amount of refrigerant.

4.2. Pipe selection

CAUTION

This unit is designed specifically for use with the R410A refrigerant. Pipes for R407C or R22 may not be used with this unit. Do not use existing pipes. Improper pipe selection will degrade performance.

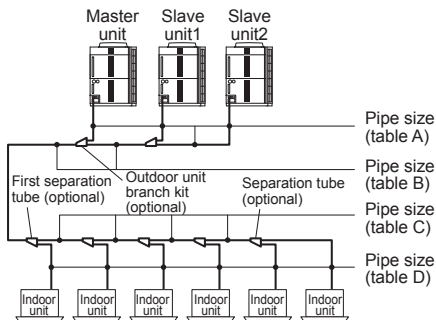

(Wall thickness and pipe material for each diameter)

| Outside Diameter | mm | 6.35 | 9.52 | 12.70 | 15.88 | 19.05 | 22.22 | 28.58 | 34.92 | 41.27 |
|-----------------------------|----------------------------------|------|------|-------|-------|-------|----------------------------------|-------|-------|-------|
| Wall Thickness ³ | mm | 0.8 | 0.8 | 0.8 | 1.0 | 1.2 | 1.0 | 1.0 | 1.2 | 1.43 |
| Material | COPPER ¹ | | | | | | COPPER ² | | | |
| | JIS H3300 C1220T-O or equivalent | | | | | | JIS H3300 C1220T-H or equivalent | | | |

*1. Allowable tensile stress ≥ 33 (N/mm²)

*2. Allowable tensile stress ≥ 61 (N/mm²)

*3. Endurance pressure of the pipes 4.2MPa

Please select the pipe size in accordance with local rules.

Table. A (Between outdoor unit and outdoor unit branch kit)

| HP | Outdoor unit cooling capacity (kW) | Outside diameter (mm) | | Branch kit ⁴ |
|----|------------------------------------|-----------------------|----------------|---------------------------|
| | | Liquid pipe | Gas pipe | |
| 8 | 22.4 | 12.70 (1/2") | 22.22 (7/8") | UTP-DX567A, UTR-CP567X |
| 10 | 28.0 | 12.70 (1/2") | 22.22 (7/8") | |
| 12 | 33.5 | 12.70 (1/2") | 28.58 (1-1/8") | |
| 14 | 40.0 | 12.70 (1/2") | 28.58 (1-1/8") | |
| 16 | 45.0 | 12.70 (1/2") | 28.58 (1-1/8") | |

*4. For the installation method, refer to "5.4. Multiple connections".

Table. B (Between outdoor unit branch kits or outdoor unit branch kit and first separation tube)

| Total cooling capacity of outdoor unit (kW) | Outside diameter (mm) | |
|---|-----------------------|----------------|
| | Liquid pipe | Gas pipe |
| 22.4 to 28.0 | 12.70 (1/2") | 22.22 (7/8") |
| 28.1 to 45.0 | 12.70 (1/2") | 28.58 (1-1/8") |
| 45.1 to 56.0 | 15.88 (5/8") | 28.58 (1-1/8") |
| 56.1 to 80.0 | 15.88 (5/8") | 34.92 (1-3/8") |
| 80.1 to 96.0 | 19.05 (3/4") | 34.92 (1-3/8") |
| 96.1 or more | 19.05 (3/4") | 41.27 (1-5/8") |

Table. C (Between separation tubes)

| Total cooling capacity of indoor unit (kW) | Outside diameter (mm) | |
|--|-----------------------|----------------|
| | Liquid pipe | Gas pipe |
| 4.4 to 11.1 | 9.52 (3/8") | 15.88 (5/8") |
| 11.2 to 13.9 | 9.52 (3/8") | 19.05 (3/4") |
| 14.0 to 28.0 | 12.70 (1/2") | 22.22 (7/8") |
| 28.1 to 44.7 | 12.70 (1/2") | 28.58 (1-1/8") |
| 44.8 to 56.0 | 15.88 (5/8") | 28.58 (1-1/8") |
| 56.1 to 80.0 | 15.88 (5/8") | 34.92 (1-3/8") |
| 80.1 to 95.0 | 19.05 (3/4") | 34.92 (1-3/8") |
| 95.1 or more | 19.05 (3/4") | 41.27 (1-5/8") |

* If the selected pipe diameter between separation tubes (based on table "C") becomes larger than the pipe diameter between outdoor unit branch kit and the first separation tube (based on table "B"), please select the pipe whose diameter is equal to the one between outdoor unit branch kit and the first separation tube.
(If pipe diameter C > B, select pipe size from table B)

* Total cooling capacity of indoor unit" is the total value for the cooling capacity of indoor unit connected downstream.

Table. D (Between separation tube to indoor unit)

| Model code | Cooling capacity of indoor unit (kW) | Outside diameter mm (in) | |
|----------------|--------------------------------------|--------------------------|--------------|
| | | Liquid pipe | Gas pipe |
| 07, 09, 12, 14 | 2.2, 2.8, 3.6, 4.0, 4.5 | 6.35 (1/4") | 12.70 (1/2") |
| 18, 24, 30 | 5.6, 7.1, 8.0, 9.0 | 9.52 (3/8") | 15.88 (5/8") |
| 36, 45, 54, 60 | 11.2, 12.5, 14.0, 18.0 | 9.52 (3/8") | 19.05 (3/4") |
| 72, 90 | 22.4, 25.0 | 12.70 (1/2") | 22.22 (7/8") |

Use a standard separation tube for pipe branching. Do not use a T tube as it does not separate the refrigerant evenly.

Table. E (Separation tube / Header)

| Total cooling capacity of indoor unit (kW) | Separation tube ⁵ | |
|--|------------------------------|--|
| | Separation tube | |
| 28.0 or less | UTP-AX090A or UTR-BP090X | |
| 28.1 to 56.0 | UTP-AX180A or UTR-BP180X | |
| 56.1 or more | UTP-AX567A or UTR-BP567X | |

• Header

| Total cooling capacity of indoor unit (kW) | Header *5 | |
|--|--------------|--------------|
| | 3-6 Branches | 3-8 Branches |
| 28.0 or less | UTR-H0906L | UTR-H0908L |
| 28.1 to 56.0 | UTR-H1806L | UTR-H1808L |

*5. For the installation method, refer to the section on "Indoor unit pipe connections" below.

4.3. Protection of pipes

- Protect the pipes to prevent the entry of moisture and dust.
- Especially pay attention when passing the pipes through a hole or connecting the end of a pipe to the outdoor unit.

| Location | Working period | Protection method |
|----------|-------------------|---------------------|
| Outdoor | 1 month or more | Pinch pipes |
| | Less than 1 month | Pinch or tape pipes |
| Indoor | — | Pinch or tape pipes |

5. PIPE INSTALLATION

5.1. Brazing

CAUTION

If air or different type of refrigerant enters the refrigeration cycle, the internal pressure in the refrigeration cycle will become abnormally high and prevent the unit from exerting its full performance.

Apply nitrogen gas while brazing the pipes.
Nitrogen gas pressure: 0.02 MPa (= sufficient pressure to be felt on the back of your hand or more)

If a pipe is brazed without applying nitrogen gas, it will create an oxidation film. This can degrade performance or damage the parts in the unit (such as the compressor or valves).

Do not use flux to braze pipes. If the flux is the chlorine type, it will cause the pipes to corrode. In addition, if the flux contains fluoride, it will affect the refrigerant piping system due to deterioration of refrigerant oil.

For brazing material, use phosphor copper that does not require flux.

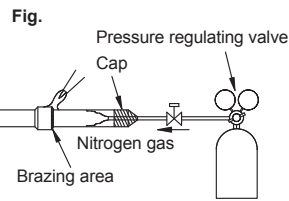

5.2. Indoor unit pipe connections

CAUTION

For details, refer to the Installation Instruction Sheet of each part.

Separation tube

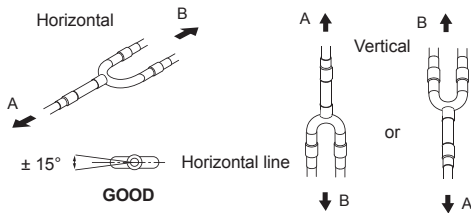

A : Outdoor unit or Refrigerant branch kit
B : Indoor unit or Refrigerant branch kit

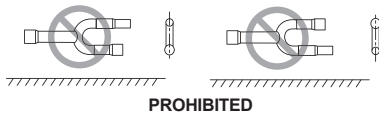

Header

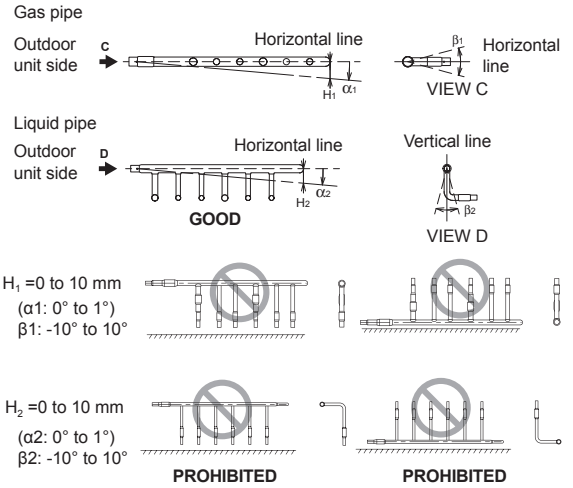

CAUTION

Do not connect a separation tube after a header.

Leave the distance 0.5 m or more for straight part to branch tube and header.

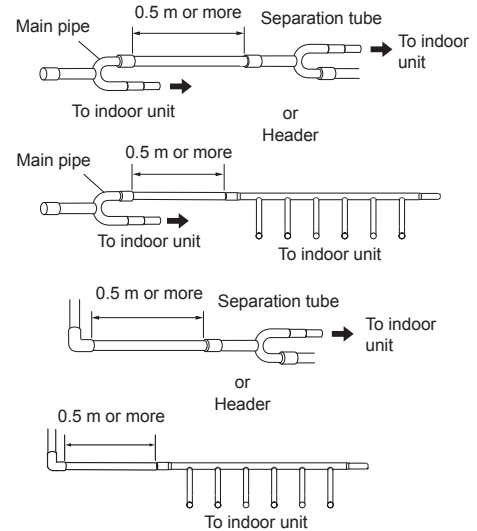

5.3. Piping method

5.3.1. Opening the knockout hole

CAUTION

Be careful to prevent panel deformation or damaged while opening the knockout hole.

To prevent cutting of the wiring after the knockout hole was opened, remove the burrs along the edge. In addition, to prevent rusting, painting the edge with rust preventive paint is recommended.

The piping can be connected from 2 directions; the front or the bottom. (Knockout holes are provided so that the piping can be connected from 2 different directions.)

Use the front knockout hole, as required.

Fig.A Knockout position

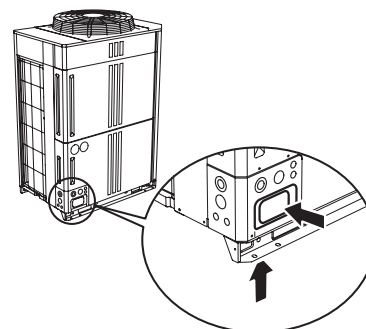

Fig. B Detail of knockout position (bottom)
(Unit: mm)

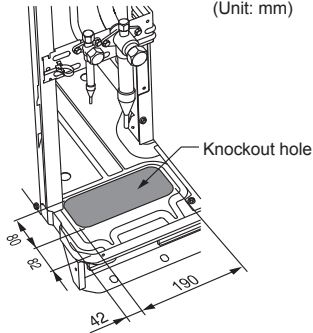
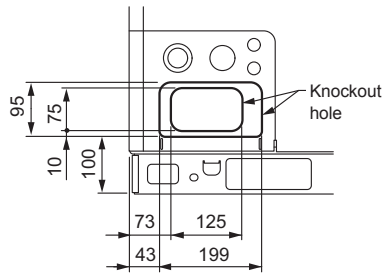

Fig. C Detail of knockout position (front)
(Unit: mm)



5. 3. 2. Removing the pinch pipe

⚠ WARNING

Remove the pinch pipe only when the internal gas is completely drained as shown on the below instructions.
If gas still remains inside, the piping may crack if you melt the brazing filler metal of the junction area with a burner.

Before connecting the piping, remove the pinch pipe in accordance with the following instructions:

- 1) Verify that the liquid side and gas side 3-way valves are closed.

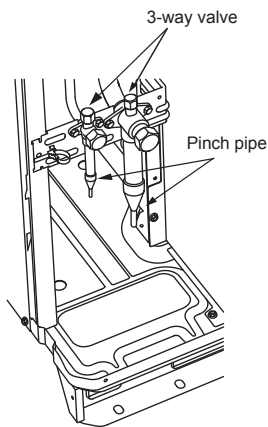

- 2) Cut the end of the liquid side and gas side pinch pipe and vent the gas inside the pinch pipe.

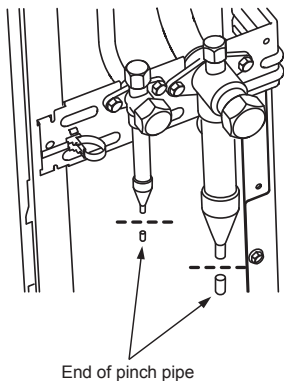

- 3) After all the gas is vented, melt the brazing filler metal on connecting part using a torch and remove the pinch pipe.

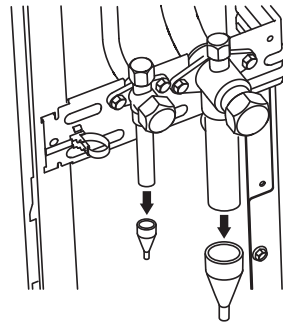

5. 3. 3. Pipe connection

⚠ CAUTION

Seal the pipe route hole with putty (field supply) such that there are no gaps. Small insects or animals that are trapped in the outdoor unit may cause a short circuit in the electrical component box.

To prevent pipe damage; do not make sharp bends. Bend the pipe at a radius of 70mm or greater.

Do not bent pipe many times at same part to prevent break.

After completing all the pipe connection by brazing, perform the indoor unit pipe connection with a flare joint.

When removing the pinch pipe or brazing the joint pipe, carry out the work while cooling down the 3-way valve sufficiently.

- Braze the joint pipe onto the 3-way valves at the liquid and gas side. Install the joint pipe appropriately so that it can be connected easily with the main pipe.
- Braze the joint pipe at the liquid and gas side with the main pipe.
* Be sure to supply nitrogen when brazing.

Fig. A

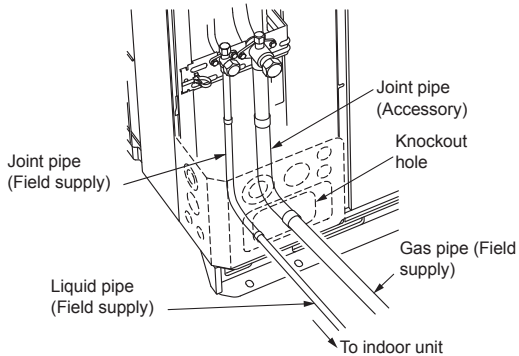
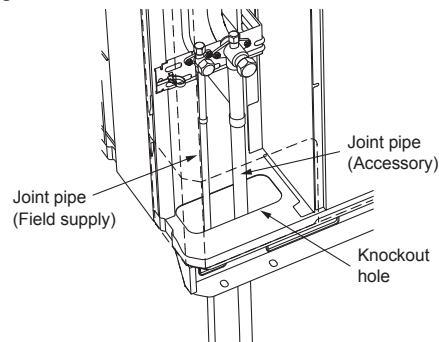

Fig. B



5. 4. Multiple connections

⚠ CAUTION

- When connecting multiple (maximum 3) units, be sure to install the unit with the largest capacity nearest to the indoor unit.
For example) AJ□126LALH (Outdoor Unit1) + AJ□126LALH (Outdoor Unit2) + AJ□A90LALH (Outdoor Unit3)
- When connecting multiple units, set the unit with the largest capacity as the master unit, and the rest as the slave units.
(Refer to 7. Field Setting)
- When connecting multiple units, use the optional outdoor unit branch kit.

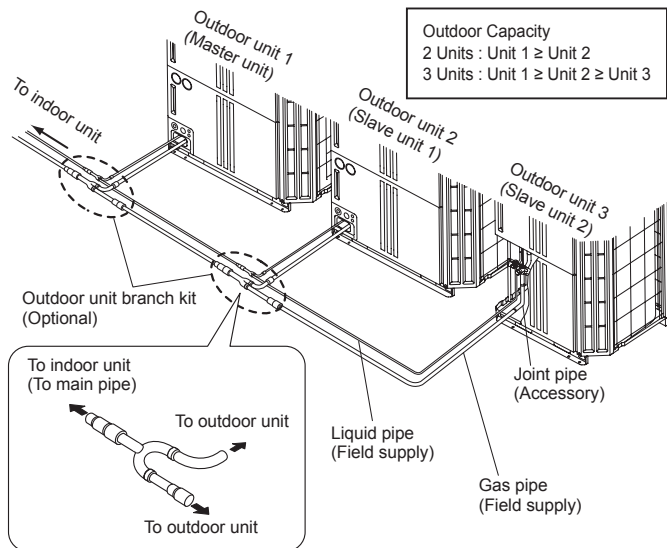

Branch kit restriction when install

Be sure following restriction.

1) Installation angle

Outdoor unit branch kit

Horizontal

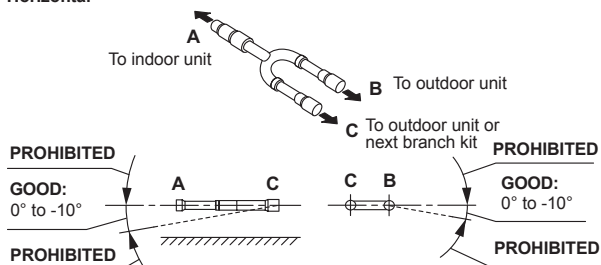

Vertical



- Install the outdoor unit branch kit horizontally level, within 0° to -10°, so that the refrigerant separates evenly.
- Do not install the outdoor unit branch kit vertically.

2) Straight pipe length

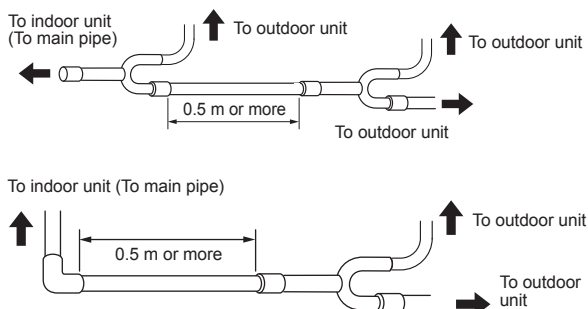

- Leave the distance 0.5 m or more for straight part to outdoor unit branch kit.

3) For details, refer to the Installation Instruction Sheet of the outdoor unit branch kit.

Fig. Examples of multiple unit installation

(Example 1)

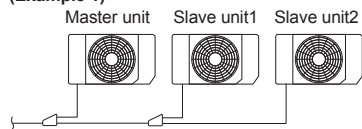

(Example 2)

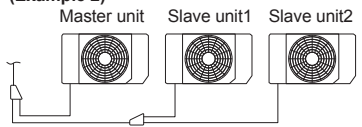

(Example 3)

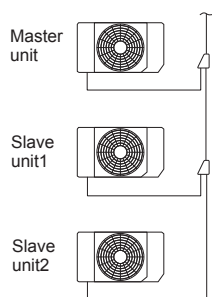

CAUTION

To prevent the oil from settling in the stopped unit, install the pipes between the outdoor units so that they are level or are tilted upward to the outdoor units.

(1) Examples of multiple unit installation are shown below.

a) Installable patterns

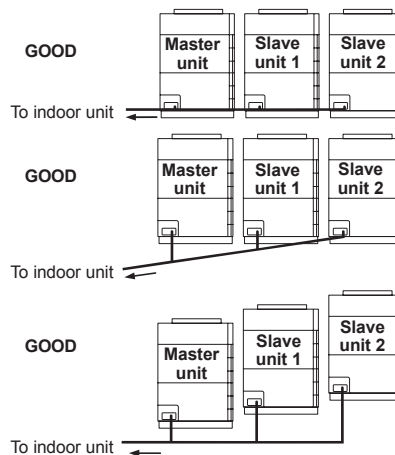

b) Non-installable patterns

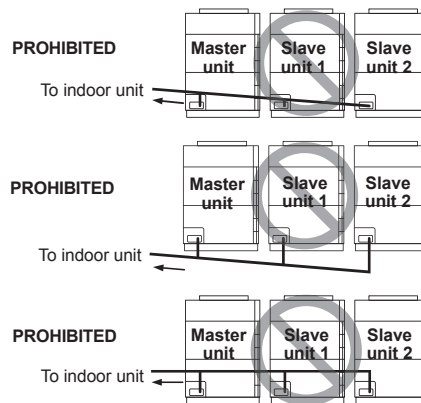

(2) If the pipe length between outdoor unit branch kit and outdoor unit branch kit (or slave unit) is longer than 2 m, or a lower pipe line exists between outdoor units, rise for gas pipe should be arranged to eliminate oil from entering into and remaining at pipes and the stopped outdoor unit. However, there is no need to provide a rise on the pipe connecting between the master unit and the indoor unit even if the length exceeds 2m.

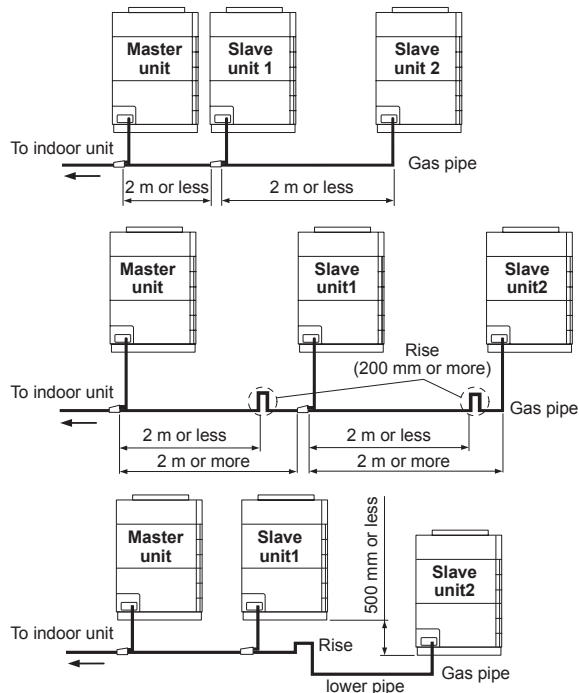

6. ELECTRICAL WIRING

6.1. The precautions of electrical wiring

⚠ WARNING

Wiring connections must be performed by a qualified person in accordance with specifications.

The rated supply of this product is 50Hz, 400V of 3-phase, 4-wire. Use a voltage within the range of 342-456V.

Make sure to perform earthing (grounding) work. Improper earthing (grounding) work can cause electric shocks.

Before connecting the cables, make sure the power supply is OFF.

Be sure to install an earth (ground) leakage breaker. Otherwise, it will cause electric shock or fire.

Be sure to install a breaker of the specified capacity. When selecting breaker, please comply with the laws and the regulations of each country. One breaker must be installed on the power supply of the outdoor unit. Wrong selection and setup of the breaker will cause electric shock or fire.

Do not connect AC power supply to the transmission line terminal board. Improper wiring can damage the entire system.

Connect the connector cord securely to the terminal.

Do not modify power cable, use extension cable or branch wiring. Improper use may cause electric shock or fire by poor connection, insufficient insulation or over current.

Make sure to secure the insulation portion of the connector cable with the cord clamp. A damaged insulation can cause a short circuit.

Never install a power factor improvement condenser. Instead of improving the power factor, the condenser may overheat.

Before servicing the unit, turn the power supply switch OFF. Then, do not touch electric parts for 10 minutes due to the risk of electric shock.

Always use a separate power supply line protected by a circuit breaker operating on all cables with a distance between contact of 3 mm for this unit.

Use crimp-type terminals and tighten the terminal screws to the specified torques, otherwise, abnormal overheating may be produced and possibly cause serious damage inside the unit.

Securely install the electrical box cover on the unit. An improperly installed service panel can cause serious accidents such as electric shock or fire through exposure to dust or water.

If the supply cable is damaged, it must be replaced by the manufacturer, its service agent or similarly qualified persons in order to avoid a hazard.

⚠ CAUTION

The primary power supply capacity is for the air conditioner itself, and does not include the concurrent use of other devices.

Connect the power cables in positive phase sequence. If they are connected in negative phase sequence, an error will be displayed. If there is a missing phase connection, the unit will not operate normally. Do not connect a N phase (neutral phase) cable to other phases (misconnection). Wrong wiring will lead to parts damage.

Do not use crossover power supply wiring for the outdoor unit.

If the electrical power is inadequate, contact your electric power company.

Install a breaker (Included with earth leakage circuit breaker) in a location that is not exposed to high temperatures. If the temperature surrounding the breaker is too high, the amperage at which the breaker cuts out may decrease.

Use a breaker (Included with earth leakage circuit breaker) that is capable of handling high frequencies. Because the outdoor unit is inverter controlled, a high-frequency breaker is necessary to prevent a malfunction of the breaker itself.

When the electrical switchboard is installed outdoors, place it under lock and key so that it is not easily accessible.

Never bundle the power supply cable and transmission cable, remote control cable together. Separate these cables by 50 mm or more. Bundling these cables together will cause miss operation or breakdown.

Always keep to the maximum length of the transmission cable. Exceeding the maximum length may lead to erroneous operation.

The static electricity that is charged to the human body can damage the control PC board when handling the control PC board for address setting, etc. Please keep caution to the following points.

Provide the earthing (grounding) of Indoor unit, Outdoor unit and Option equipment. Cut off the power supply (breaker).

Touch the metal section (such as the unpainted control box section) of the indoor or outdoor unit for more than 10 seconds. Discharge the static electricity in your body. Never touch the component terminal or pattern on the PC board.

6.2. Wiring method

The wiring example for outdoor units and indoor units is shown in the figure.

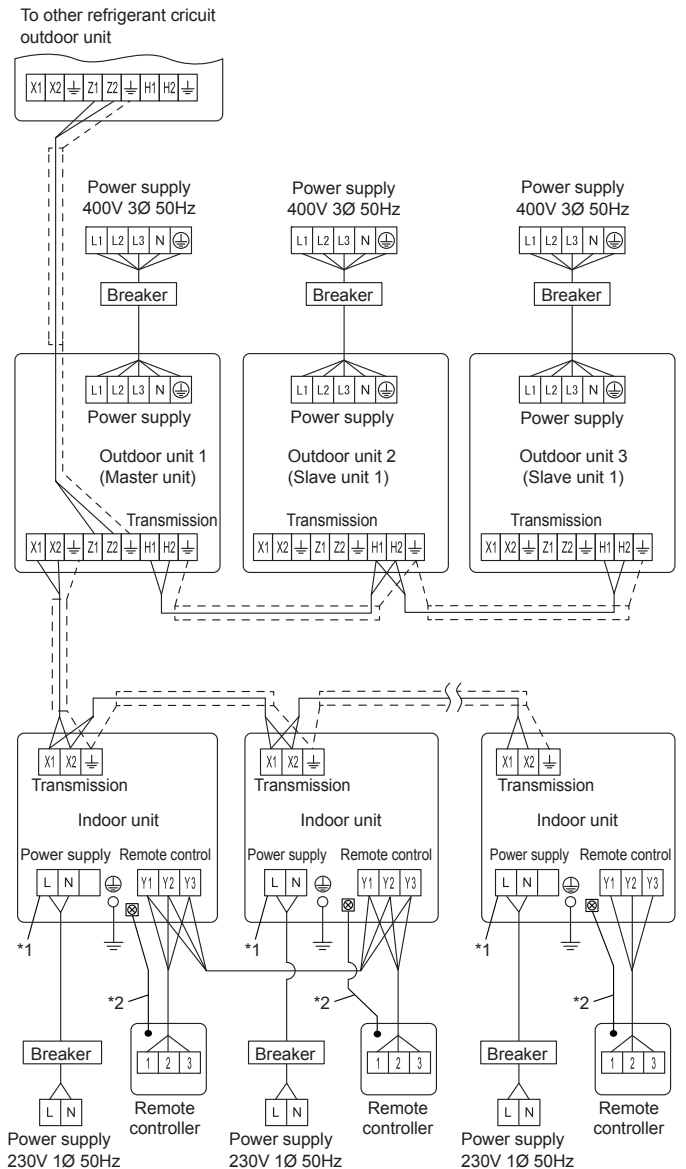

*1: The number of power supply terminals is different depending on the indoor unit model. For the wiring, refer to the indoor unit installation manual.

*2: Earth (Ground) the remote controller if it has an earth (ground) cable.

• There are two types of remote controller: the 2-wire type and the 3-wire type. For details, see the relevant remote controller installation manual. (When connecting the 2-wire type remote controller, Y3 is not used.)

6.3. Knockout hole

⚠ CAUTION

Seal the wiring route hole with putty (field supply) such that there are no gaps. Small insects or animals that are trapped in the outdoor unit may cause a short circuit in the electrical component box.

Be careful not to deform or scratch the panel while opening the knockout holes.

After opening the knockout hole, remove the burr on the edges to prevent snapping of cables. It is recommended to apply rust proof paint on the edges to prevent rust.

Electric wires can be connected from the front or from the left. (Knockout holes are prepared so that wiring can be made from 2 different directions.) Use the knockout holes on the front and the left separately when necessary.

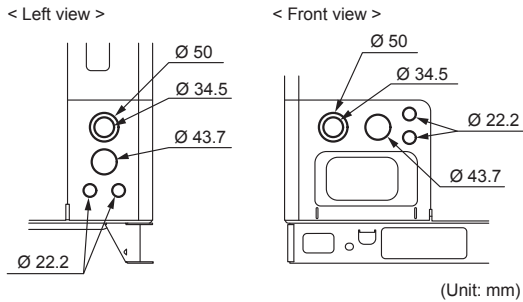
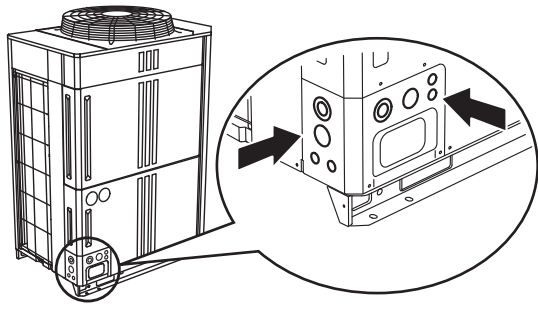

6.4. Selecting power supply cable and breaker

⚠ CAUTION

Obtain the distribution network operator's agreement about the power capacity of the power supply system, specification of the cable and the harmonic current, and etc. when you connect the outdoor unit with the power supply.

Regulation of wire size and circuit breaker differs from each locality, please refer in accordance with local rules.

Refer to the table for the wiring and breaker specifications of each installation condition.

(1) Selecting power supply cable and breaker when connecting 1 outdoor unit

| MODEL | Breaker (Time delay fuse or circuit capacity) | |
|------------|---|-------------------------|
| | Fuse capacity (A) | Leakage current |
| AJ□A72LALH | 30 | 100mA 0.1sec or less |
| AJ□A90LALH | 30 | |
| AJ□108LALH | 50 | |
| AJ□126LALH | 50 | |
| AJ□144LALH | 50 | |

| MODEL | Outdoor unit power supply cable | | |
|------------|---------------------------------------|--------------------------------|----------------------------|
| | Power supply cable (mm ²) | Ground wire (mm ²) | Critical wiring length (m) |
| AJ□A72LALH | 4 | 4 | 30 |
| AJ□A90LALH | 4 | 4 | 30 |
| AJ□108LALH | 10 | 6 | 42 |
| AJ□126LALH | 10 | 6 | 42 |
| AJ□144LALH | 10 | 6 | 42 |

- 1) These values are recommended data.
- 2) Specification: Use conformed cord with Type 60245 IEC66
- 3) Max. wire length: Set a length so that the voltage drop is less than 2%. Increase the wire diameter when the wire length is long.

Fig. In case of connected outdoor unit

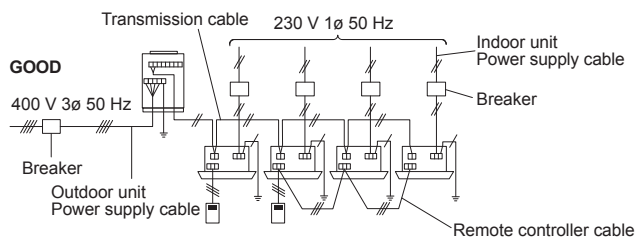

(2) Selecting main breaker and main power supply cable when connecting multiple outdoor units

Main breaker: Main breaker ≥ Total Sub breaker (Refer to the table in item (1) for the sub breaker capacity)

Fig. In case of connected 3 outdoor unit

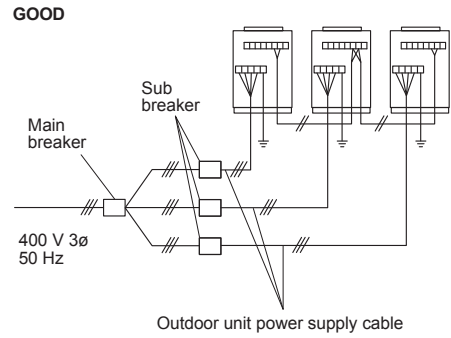

(3) Example of bad breaker wiring

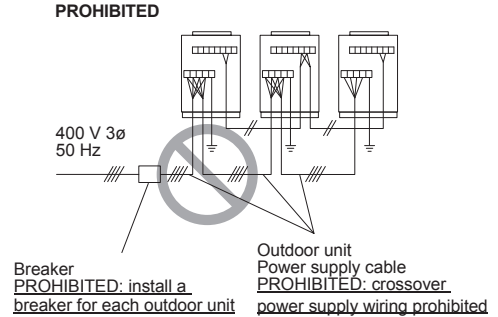

6.5. Transmission line

⚠ CAUTION

- Caution when wiring cable
When stripping off the coating of lead wire, always use the exclusive tool such as a wire stripper. If there is no exclusive tool available necessarily, carefully strip the coating by a cutter etc. so that the conductive wire is not damaged. If it is damaged, it may lead to an open circuit and a communication error.

- Pay attention to the following points while attaching wires on the terminal board.
Do not attach 2 wires on one side.
Do not twist wires.
Do not cross the wires.
Do not shorted at edge at root.

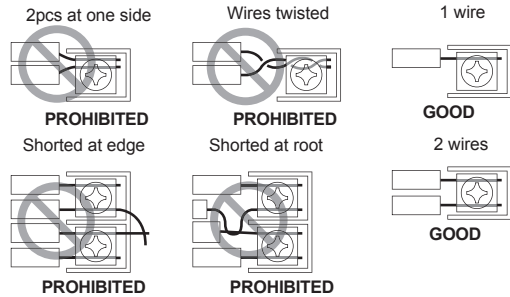

6.5.1. Transmission wiring specifications

Follow the specifications below for the transmission cable.

| Use | Size | Wire type | Remarks |
|--------------------|---------------------|---|----------------------------|
| Transmission cable | 0.33mm ² | 22AWG LEVEL 4 (NEMA) non-polar 2core, twisted pair solid core diameter 0.65mm | LONWORKS® compatible cable |

6.5.2. Wiring rules

- (1) Total length of transmission cable
Total transmission line length : Max. 3,600 m
EF + EG + GH + HJ + HK + KL < 3,600 m (Fig.2)
In the following cases, Signal Amplifier is required.
① When the total length of the transmission line exceeded 500 m.
AB + BC + BD > 500 m (Fig.1)
② When the total number of units* is over 64.
③ Transmission line length between each unit* ≥ 400 m
- (2) Length of transmission cable between 1 network segment (NS)
EF + EG + GH + HJ + HK ≤ 500 m (Fig.2)
KL ≤ 400 m (Fig.2)
- (3) Length of transmission cable between outdoor units in a refrigerant system
MN ≤ 18 m
NP ≤ 18 m

Fig.1

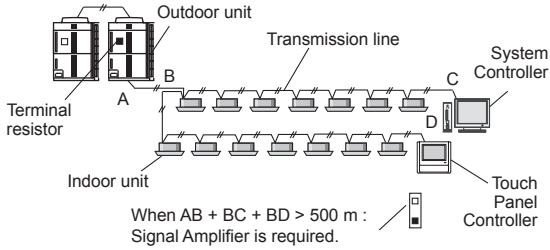
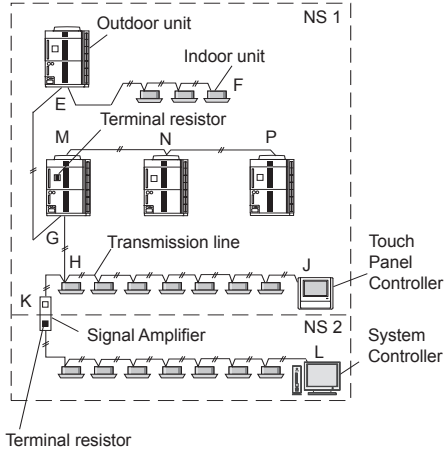

Fig.2



NOTE)

Unit* means indoor unit, outdoor unit, Touch Panel Controller and System Controller, Signal Amplifier, single split adaptor, Network Converter etc..

Do not use loop wiring. This may lead to parts damage and erroneous operation.

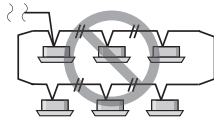

6.5.3. Enabling/Disabling automatic address setting

You can enable/disable automatic address setting for the indoor unit and the signal amplifier.

To enable automatic address setting for the indoor unit, connect the indoor unit to outdoor units under the same refrigerant system.(Fig.4)

Example : Disable Automatic Address setting

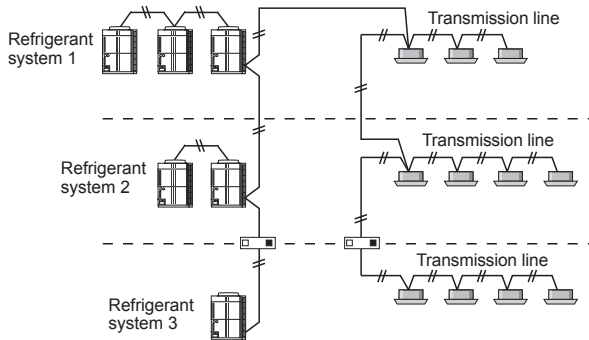

Example : Enable Automatic Address setting

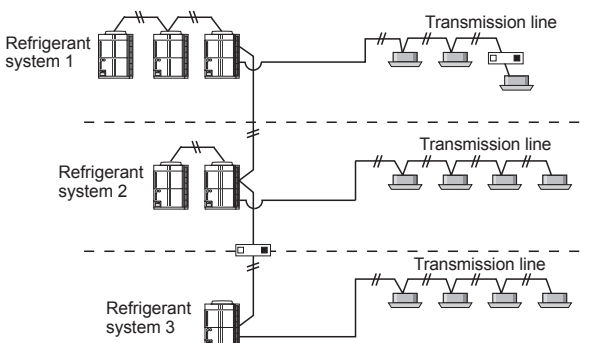

6.6. Wiring procedure

- Remove the cover of the electrical compartment and follow the terminal plate to connect the electric cables to the terminal.
- After connecting the cables, secure them with the cable ties.
- Connect the cables without applying excessive tension.

Cable routing

Secure with a binder as shown in the figure below.

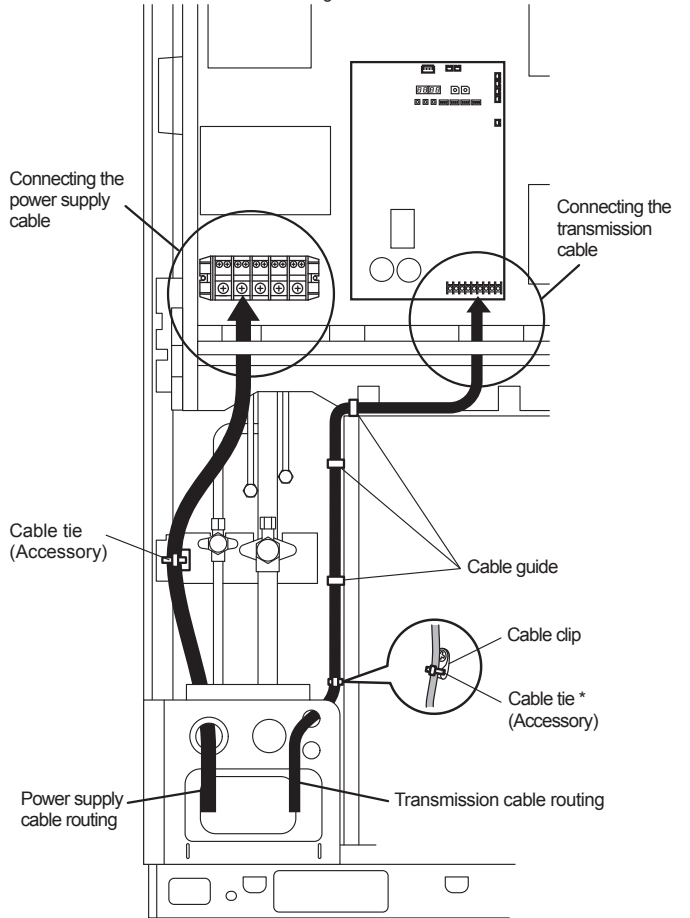

* Tighten the cable tie firmly so that pulling force does not propagate to the terminal connection even if force of 100N is applied to the cable.

Connecting cables to the terminals

| ⚠ WARNING | |
|---|--|
| Use ring terminals and tighten the terminal screws to the specified torques, otherwise, abnormal overheating may be produced and possibly cause heavy damage inside the unit. | |
| Be sure fill the holes of power supply cable and transmission cable with putty (field supply). If small animals such as insects enter the electrical component box, a short circuit may be caused. | |

| Tightening torque | |
|-------------------|----------------------------------|
| M3 screw | 0.5 to 0.6 N·m (5 to 6 kgf·cm) |
| M8 screw | 5.0 to 7.0 N·m (50 to 70 kgf·cm) |

(1) Connecting the power supply cable

Caution when wiring cable

- 1) Use crimp-type terminals with insulating sleeves as shown in the figure to connect to the terminal block.
- 2) Securely clamp the crimp-type terminals to the cables using an appropriate tool so that the cables do not come loose.
- 3) Use the specified cables, connect them securely, and fasten them so that there is no stress placed on the terminals.
- 4) Use an appropriate screwdriver to tighten the terminal screws. Do not use a screwdriver that is too small, otherwise, the screw heads may be damaged and prevent the screws from being properly tightened.
- 5) Do not tighten the terminal screws too much, otherwise, the screws may break.
- 6) See the table for the terminal screw tightening torques.

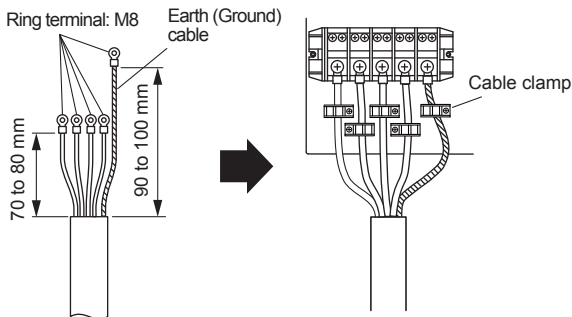
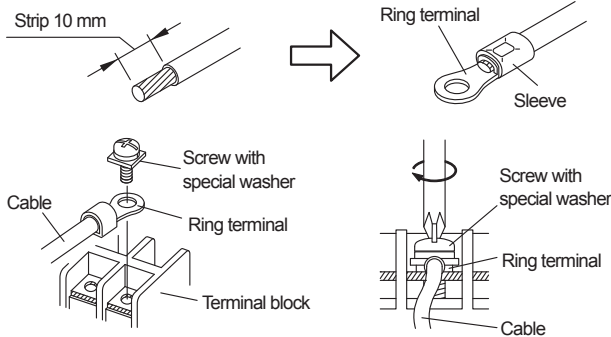

* Use a ring terminal to connect the electric cables to the power supply terminal board.

(2) Connecting the transmission cable

Sealing transmission cable

Connect both ends of the sealed wires of the transmission cable to the earth terminal of the equipment or to the earth screw near the terminal. Be very careful that the screws are not overly tightened as the wires may snap and the terminal may be damaged.

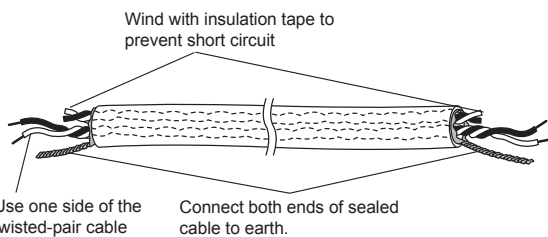

Be sure to use one side of a twisted-pair cable when using transmission cable with 2 sets of twisted-pair cables.

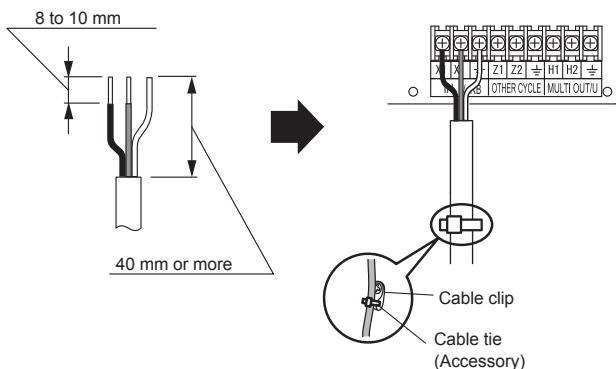

6. 7. External input and external output

6. 7. 1. Terminal position

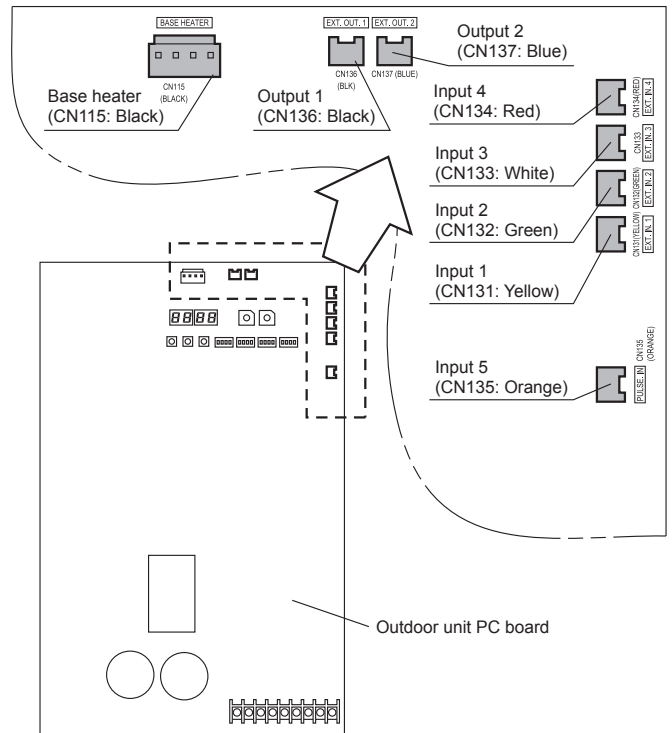

CAUTION

Do not bundle the cable for base heater with other cables.

(Example)

In case of Outdoor unit

- (1) Insert the connector to CN136 (Black) and CN137 (Blue) of control PC board.
- (2) Fix it to the wire with the attached cable tie.

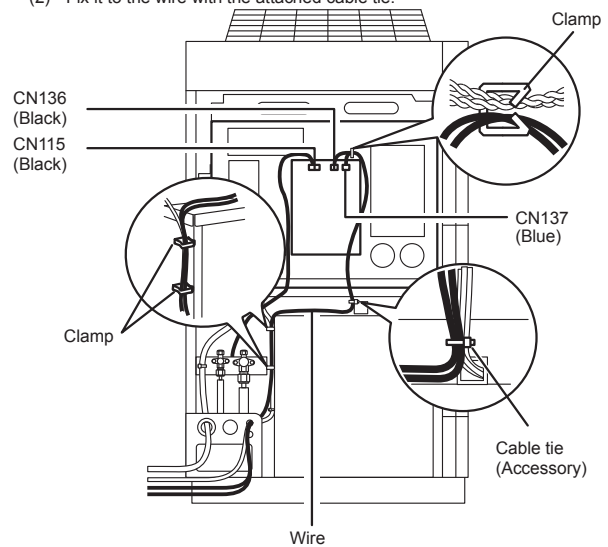

* Do not clamp the base heater cable.

6. 7. 2. External input terminal

Service parts: EXTERNAL INPUT WIRE A (9368777005)

- Setting to low noise mode, outdoor unit operation peak control setting, emergency/ batch stop and electricity meter pulse are possible from the outside.
- Except for wattmeter pulse reception (CN135) among external input terminals, only the Master unit is effective.

Wiring method and specifications

- * A twisted pair cable (0.33 mm² (22AWG)) should be used. Maximum length of cable is 150 m.
- * Use an external input and output cable with appropriate external dimension, depending on the number of cables to be installed
- * For each input, pin No.1 is of positive polarity and pin No.2 is of ground level.

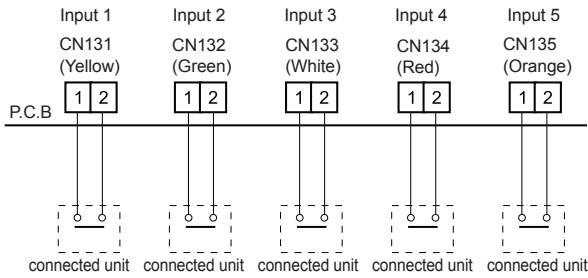

Operation behavior

Each input terminal works as follows.

| Connector | Input signal | Status | Outdoor unit | |
|------------------------------|--------------|--|--------------|-------|
| | | | Master | Slave |
| Input 1 CN131 (Yellow) | OFF | Normal operation | | × |
| | ON | Low noise mode operation | ○ | |
| Input 2 CN132 (Green) *1 | OFF | Cooling priority | ○ | × |
| | ON | Heating priority | | |
| Input 3 CN133 (White) | OFF | Normal operation | | × |
| | ON | Outdoor unit operation peak control | ○ | |
| Input 4 CN134 (Red) | OFF | Normal operation | | × |
| | ON | Batch stop or Emergency stop operation *2, *3 | ○ | |
| Input 5 CN135 (Orange) *4 | No pulse | No information from electricity meter | ○ | ○ |
| | Pulse | Power usage information from electricity meter | | |

Slave unit can connect only input5 (CN135).

The operations of each input terminal and the selection of function are set with the push button on the PC board of outdoor unit. About the setting, please refer to 7.4. Push button setting.

Note :

- *1: The "external input priority mode" must be set by pressing push button on PC board of outdoor unit.
- *2: Batch stop or Emergency stop pattern can be selected by outdoor unit PC board push button.
- *3: The emergency stop function mounted in the V-II does not guarantee the regulations of each country. For this reason, sufficient checking is necessary regarding use.
Especially, since the fact that the equipment may not be emergency-stopped in the case of breaking of the wiring to the external input terminals and communication line, communication error due to noise, VRF external input circuit trouble, etc. must be considered, the provision of double measures that add direct interruption of the power supply by switch, etc. is recommended as a precaution.
- *4: Pulse input to CN135 must be width 50ms or more, and must be interval 50ms or more.

6.7.3. External output terminal

Service parts : EXTERNAL INPUT WIRE A (9368777005)

- You can detect the operation condition of outdoor unit and the abnormal situation of both indoor and outdoor unit.
- The external output terminal is only valid for Master Unit.

Wiring method and specifications

Error status (Master unit only)

This output indicates the outdoor unit and connected indoor unit's "Normal" or "Error" status.

Operation status (Master unit only)

This output indicates the outdoor unit's "Operation" status.

| Connector | Output voltage | Status |
|---------------|----------------|-----------|
| CN136 (Black) | 0 V | Normal |
| | DC 12 to 24 V | Error |
| CN137 (Blue) | 0 V | Stop |
| | DC 12 to 24 V | Operation |

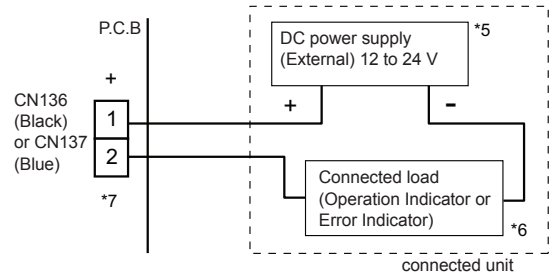

- * 5: Provide a DC-12 to 24 V power supply.
Select a power supply capacity with an ample surplus for the connected load.
- * 6: The allowable current is 30 mA or less.
Provide a load resistance such that the current becomes 30 mA or less.
- * 7: Polarity is [+] for pin 1 and [-] for pin 2. Connect correctly.
Do not impress a voltage exceeding 24 V across pins 1-2.
- * A twisted pair cable (0.33 mm² (AWG22)) should be used. Maximum length of cable is 150 m.
- * Use an external input and output cable with appropriate external dimension, depending on the number of cables to be installed.

6.7.4. Base heater terminal

Service parts : WIRE WITH CONNECTOR (9708642000)

This is the output signal for base heater. Output signal ON, when the outdoor temperature goes down below 2°C, and signal OFF at the outdoor temperature 4°C.

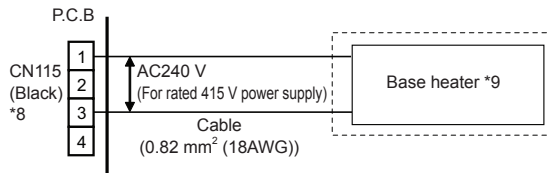

- * 8: Connect to pin 1 and pin 3. No connection pin 2 and pin 4.
- * 9: The allowable current is 1 A or less.

7. FIELD SETTING

CAUTION

Discharge the static electricity from your body before setting up the DIP switches. Never touch the terminals or the patterns on the parts that are mounted on the board.

7.1. Field setting switches

Remove the service panel of the outdoor unit and the cover of the electrical component box to access the PC board of the outdoor unit.
PC board switches for various settings and LED indicators are shown in the figure.

7.2. DIP switch setting

7.2.1. List of Settings

SET3 and SET5 must be set for the DIP switch.

Configure the settings before turning on the power. Settings for SET1, SET2, and SET4 DIP switches are factory default ones. Do not change them.

| DIP Switch | Function |
|------------|--|
| SET1 | 1-4 Forbidden |
| SET2 | 1-4 Forbidden |
| SET3 | 1 Outdoor unit address setting |
| | 2 Setting for number of slave units |
| | 3 Setting for number of slave units |
| SET4 | 1-4 Forbidden |
| SET5 | 1-2 Number of outdoor units installed |
| | 3 Forbidden |
| | 4 Terminal resistor setting |

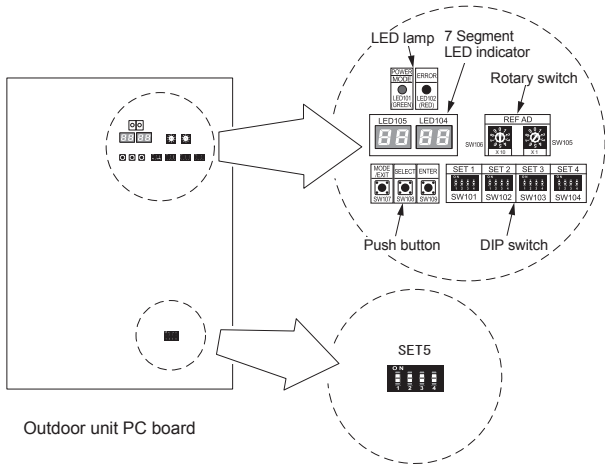

Outdoor unit PC board

7.2.2. Settings to be configured locally

(1) Outdoor unit address setting

When 2 or 3 outdoor units are installed to 1 refrigerant system, set the address for each outdoor unit.

Set the address for all outdoor units.

| SET3 | | Outdoor unit address | Remarks |
|------|-----|----------------------|-------------------------------|
| 1 | 2 | | |
| OFF | OFF | 0 | Master unit (Factory setting) |
| OFF | ON | 1 | Slave unit 1 |
| ON | OFF | 2 | Slave unit 2 |
| ON | ON | - | Forbidden |

(2) Number of slave units setting for outdoor unit

Set the number of slave units connected to 1 refrigerant system.

Set only the master unit.

| SET3 | | Number of connectable outdoor units | Remarks |
|------|-----|-------------------------------------|------------------------------------|
| 3 | 4 | | |
| OFF | OFF | 0 | Master unit only (Factory setting) |
| OFF | ON | 1 | 1 slave unit connected |
| ON | OFF | 2 | 2 slave unit connected |
| ON | ON | - | Forbidden |

(3) Number of outdoor units installed

The number of outdoor units installed in 1 refrigerant system must be set.

Set for all outdoor units.

| SET5 | | Number of outdoor units | Remarks |
|------|-----|-------------------------|-------------------|
| 1 | 2 | | |
| OFF | OFF | 1 | (Factory setting) |
| OFF | ON | 2 | - |
| ON | OFF | 3 | - |
| ON | ON | - | Forbidden |

7.2.3. Terminal resistor setting

⚠ CAUTION

Be sure to set the terminal resistor according to specifications. Set the terminal resistor for every network segment (NS).

If terminal resistor is set in multiple devices, the overall communication system may be damaged.

If terminal resistor is not set in a device, abnormal communication may occur.

- Be sure to set 1 terminal resistor in a network segment. You can set the terminal resistor at the outdoor unit or signal amplifier.
- When setting the terminal resistor of a signal amplifier, refer to the installation manual of the signal amplifier.
- When setting multiple terminal resistors, take note of the following items.
 - ① How many network segments are there in a VRF system?
 - ② Where will you set the terminal resistors in a network segment? (Condition for 1 segment: Total number of outdoor and indoor units and signal amplifiers is less than 64, or the total length of the transmission cable is less than 500m)
 - ③ How many outdoor units are connected to 1 refrigerant system?

Configure the setting (DIP switch SET5) of the terminal resistor of the outdoor units as shown below from conditions ① to ③.

| SET5 | Terminal resistor | Remarks |
|------|-------------------|-------------------|
| 4 | Terminal resistor | |
| OFF | Disable | (Factory setting) |
| ON | Enable | - |

Figure: Terminal resistor setting

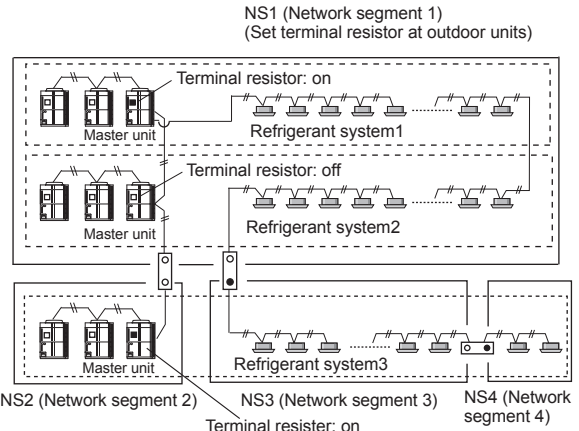

NS2 (Network segment 2) NS3 (Network segment 3) NS4 (Network segment 4)

About the setting of terminal resistor

Outdoor unit (Master unit)

- :on
- :off
- Install
- Do not install

7.3. Rotary switch setting

The rotary switch (REF AD) sets the refrigerant circuit address of the outdoor unit. Configure the settings only on the master unit of a refrigerant system. If multiple refrigerant systems are connected, set the rotary switch (REF AD) as shown in the table below.

| Refrigerant circuit address | Rotary Switch Setting | |
|-----------------------------|-----------------------|----|
| | REF AD | |
| | ×10 | ×1 |
| 0 | 0 | 0 |
| 1 | 0 | 1 |
| 2 | 0 | 2 |
| 3 | 0 | 3 |
| 4 | 0 | 4 |
| · | · | · |
| · | · | · |
| 97 | 9 | 7 |
| 98 | 9 | 8 |
| 99 | 9 | 9 |

| Setting | Setting range | Type of switch |
|-----------------------------|---------------|---|
| Refrigerant circuit address | 0-99 | Setting example 63 REF AD × 10 REF AD × 1 |

Rotary Switch (REF AD×1): Factory setting "0"
Rotary Switch (REF AD×10): Factory setting "0"

7.4. Push button setting

Various functions can be set when necessary.
Perform settings after all indoor units have stopped operation.

Table A: List of Settings

| No | Setting Item | | 7 segment LED indicator | | | | Factory setting |
|--|--|--|-------------------------|---|---------------|---|-----------------|
| | | | First 2 digits | | Last 2 digits | | |
| 00 | Pipe length setting *1 | Standard (40 to 65 m) | 0 | 0 | 0 | 0 | ● |
| | | Short (less than 40 m) | | | 0 | 1 | |
| | | Medium (65 to 90 m) | | | 0 | 2 | |
| | | Long 1 (90 to 120 m) | | | 0 | 3 | |
| | | Long 2 (120 to 150 m) | | | 0 | 4 | |
| Pipe length means the length between master outdoor unit and the nearest indoor unit. | | | | | | | |
| 10 | Sequential start shift *1 | Normal | 1 | 0 | 0 | 0 | ● |
| | | 21 sec. Delay | | | 0 | 1 | |
| | | 42 sec. Delay | | | 0 | 2 | |
| | | 63 sec. Delay | | | 0 | 3 | |
| The start-up timing of outdoor unit (compressor) can be set up so that it can delay several seconds. This feature is useful when multiple number of outdoor units are installed and turned on at the same time to limit the starting current. | | | | | | | |
| 11 | Cooling capacity shift *1 | Normal mode | 1 | 1 | 0 | 0 | ● |
| | | Save energy mode | | | 0 | 1 | |
| | | High power mode 1 | | | 0 | 2 | |
| | | High power mode 2 | | | 0 | 3 | |
| | | (Forbidden) | | | 0 | 4 | |
| Set this item when necessary. | | | | | | | |
| 12 | Heating capacity shift *1 | Normal mode | 1 | 2 | 0 | 0 | ● |
| | | Save energy mode | | | 0 | 1 | |
| | | High power mode 1 | | | 0 | 2 | |
| | | High power mode 2 | | | 0 | 3 | |
| Set this item when necessary. | | | | | | | |
| 13 | (Forbidden) | 1 | 3 | 0 | 0 | ● | |
| 20 | Switching between batch stop or emergency stop *1 | Batch stop | 2 | 0 | 0 | 0 | ● |
| | | Emergency stop | | | 0 | 1 | |
| This mode selects the pattern of the stop function to be operated by the external input terminal (CN134). • Batch stop: The stop of all indoor units connected to same refrigerant system due to input signal coming from CN134. • Emergency stop: When emergency stop is actuated, the indoor unit does not accept the operation command from the remote controller. On the other hand, when the emergency stop is released (no input from CN134), the air conditioner does not return to the original operation until the indoor unit is turned on by the remote controller. | | | | | | | |
| 21 | Operation mode selecting method *1 | Priority given to the first command | 2 | 1 | 0 | 0 | ● |
| | | Priority given to external input of outdoor unit | | | 0 | 1 | |
| | | Priority given to administrative indoor unit | | | 0 | 2 | |
| Select the priority setting of the operation mode. • Priority given to the first command: Priority is given to the operation mode which is set first. • Priority given to external input of outdoor unit: Priority is given to the operation mode which is set by the external input terminal (CN132). • Priority given to administrative indoor unit: Priority is given to the operation mode of the administrative indoor unit which is set by the wired remote controller. | | | | | | | |
| 22 | Snow falling protection fan mode *1 | Normal mode | 2 | 2 | 0 | 0 | ● |
| | | Snow falling protection fan mode | | | 0 | 1 | |
| This mode operates the fans of outdoor units in order to prevent the units from stopping operation when they are covered by snow. | | | | | | | |
| 23 | Interval setting for snow falling protection fan mode *1 | Standard (30 minutes) | 2 | 3 | 0 | 0 | ● |
| | | Short 1 (5 minutes) | | | 0 | 1 | |
| | | Short 2 (10 minutes) | | | 0 | 2 | |
| | | Short 3 (20 minutes) | | | 0 | 3 | |
| When the snow falling protection fan mode is set, the operation interval of the fans of outdoor units can be selected. | | | | | | | |

| | | | | | | | |
|--|--|---|---|---|-----|-----|---|
| 24 | High static pressure mode | Standard | 2 | 4 | 0 | 0 | ● |
| | | High static pressure 1 (equivalent to 30Pa) | | | 0 | 1 | |
| | | High static pressure 2 (equivalent to 80Pa) | | | 0 | 2 | |
| | | (Forbidden) | | | 0 | 3 | |
| When installing a duct to the blow-off outlet of an outdoor unit, set the high static pressure mode according to the static pressure of the duct to be installed. Furthermore, use this setting if the air blow of an outdoor unit is poor, such as when installed in a place with a low ceiling. | | | | | | | |
| 25 | (Forbidden) | 2 | 5 | 0 | 0 | ● | |
| 26 | (Forbidden) | 2 | 6 | 0 | 0 | ● | |
| 27 | (Forbidden) | 2 | 7 | 0 | 0 | ● | |
| 28 | (Forbidden) | 2 | 8 | 0 | 0 | ● | |
| 29 | (Forbidden) | 2 | 9 | 0 | 0 | ● | |
| 30 | Energy saving level setting *1 | Level 1 (stop) | 3 | 0 | 0 | 0 | ● |
| | | Level 2 (operated at 40% capacity) | | | 0 | 1 | |
| | | Level 3 (operated at 60% capacity) | | | 0 | 2 | |
| | | Level 4 (operated at 80% capacity) | | | 0 | 3 | |
| | | Level 5 (operated at 100% capacity) | | | 0 | 4 | |
| The capacity limit can be selected by the external input terminal (CN133) when operating with the "Energy Saving Peak Cut function". The lower the level, the more the effect of energy saving, but the cooling/heating performance will also drop. | | | | | | | |
| 40 | Capacity priority setting (in low noise mode) *1 | Off (quiet priority) | 4 | 0 | 0 | 0 | ● |
| | | On (capacity priority) | | | 0 | 1 | |
| If the cooling/heating performance becomes insufficient when the low noise mode is set, it is possible to set "capacity priority" that automatically cancels the low noise mode (once performance is restored, the mode will automatically return to the low noise mode). | | | | | | | |
| 41 | Low noise mode setting *1 | Off (Normal) | 4 | 1 | 0 | 0 | ● |
| | | On (Low noise mode) | | | 0 | 1 | |
| 42 | Low noise mode operation level setting *1 | Level 1 (55 dB) | 4 | 2 | 0 | 0 | ● |
| | | Level 2 (50 dB) | | | 0 | 1 | |
| The noise level when operating in the low noise mode can be set. | | | | | | | |
| 60 | Back up operation 1 *1 | On | 6 | 0 | 0 | 0 | ● |
| | | Off | | | 0 | 1 | |
| 70 | Electricity meter No. setting 1 *2 | Setting number (x00) | 7 | 0 | 0 | 0 | ● |
| | | Setting number (x01) | | | 0 | 1 | |
| | | | | | ... | ... | |
| | | Setting number (x98) | | | 9 | 8 | |
| Set the ones digit and tens digit of the No. of the electricity meter connected to CN135. | | | | | | | |
| 71 | Electricity meter No. setting 2 *2 | Setting number (0xx) | 7 | 1 | 0 | 0 | ● |
| | | Setting number (1xx) | | | 0 | 1 | |
| | | Setting number (2xx) | | | 0 | 2 | |
| Set the hundreds digit of the No. of the electricity meter connected to CN135. | | | | | | | |
| 72 | Electricity meter pulse setting 1 *3 | Setting number (xx00) | 7 | 2 | 0 | 0 | ● |
| | | Setting number (xx01) | | | 0 | 1 | |
| | | | | | ... | ... | |
| | | Setting number (xx98) | | | 9 | 8 | |
| Set the ones digit and tens digit of the No. of the electricity meter pulse setting connected to CN135. | | | | | | | |

| | | | | | | |
|----|--------------------------------------|-----------------------|-----|-----|---|---|
| 73 | Electricity meter pulse setting 2 *3 | Setting number (00xx) | 0 | 0 | ● | |
| | | Setting number (01xx) | 0 | 1 | | |
| | | | ... | ... | | |
| | | Setting number (98xx) | 9 | 8 | | |
| | | Setting number (99xx) | 9 | 9 | | |
| 90 | (Forbidden) | 9 | 0 | 0 | 0 | ● |

- *1: Do not set this for outdoor units with Slave setting.
- *2: When electricity meter No. is set to "000" and "201 to 299", the pulses input to CN135 become ineffective. Available setting number is "001" to "200"
- *3: When the electricity meter pulse setting is set to "0000", the pulses input to CN135 become ineffective. Available setting number is "0001" to "9999"

- (1) Turn on the power of the outdoor unit and enter standby mode.
- When system is normal

POWER/MODE lamp lights up. (ERROR lamp is off.)

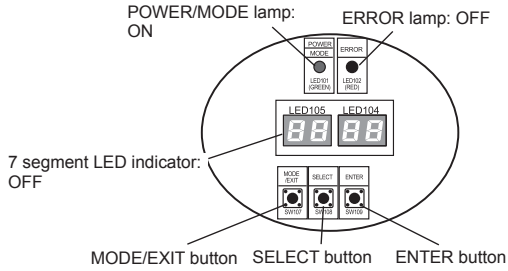

- When system is abnormal
- Check the settings as there is an error in the settings for outdoor unit address (DIP switch SET3-1, 2) or number of connected slave units (DIP switch SET3-3, 4).

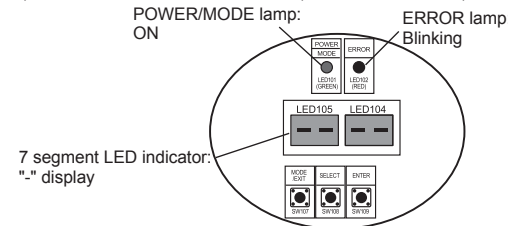

- (2) Setting method
- Use the "MODE/EXIT", "SELECT", and "ENTER" buttons to configure settings according to the procedures below. (If no setting is made, the factory default setting will be displayed.)

- MODE/EXIT** : Press the "MODE/EXIT" button.
- SELECT** : Press the "SELECT" button.
- ENTER** : Press the "ENTER" button.
- ENTER** (with diagonal lines) : Press the "ENTER" button for more than 3 seconds.

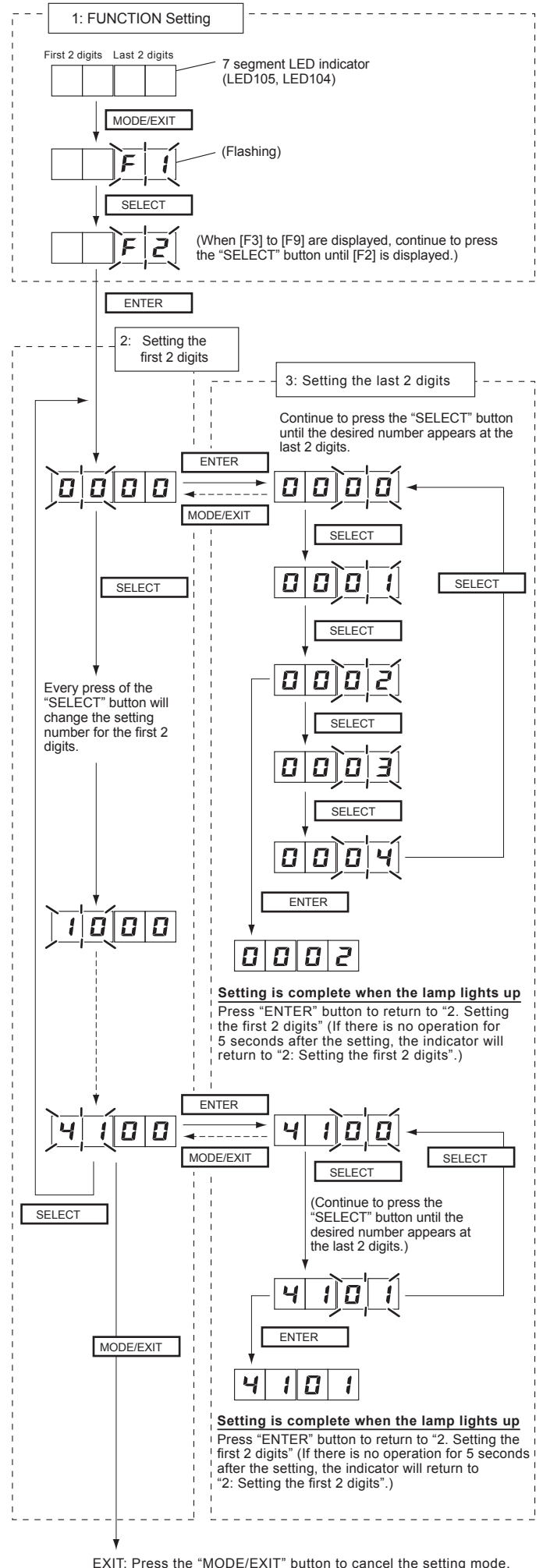

7.5. Signal amplifier address setting

7.5.1. Signal amplifier address setting

When using signal amplifiers, the address for signal amplifiers must be set. The address for signal amplifiers can be set automatically from 1 outdoor unit (master unit) on the network.

Refer to the next section "Fig. Wiring example for automatic address setting" for the wiring example.

(For manual setting of address, refer to the signal amplifier installation manual.)

7.5.2. Procedures to enable automatic address setting on signal amplifier

When setting the address of the signal amplifier, please use the factory setting. (See the installation manual of the signal amplifier)

When the system is normal, nothing will be displayed on the 7 segment indicator.

When ERROR is displayed, inspect the units.

Use the "MODE/EXIT", "SELECT", and "ENTER" buttons on the outdoor unit PC board to configure settings according to the procedures below.

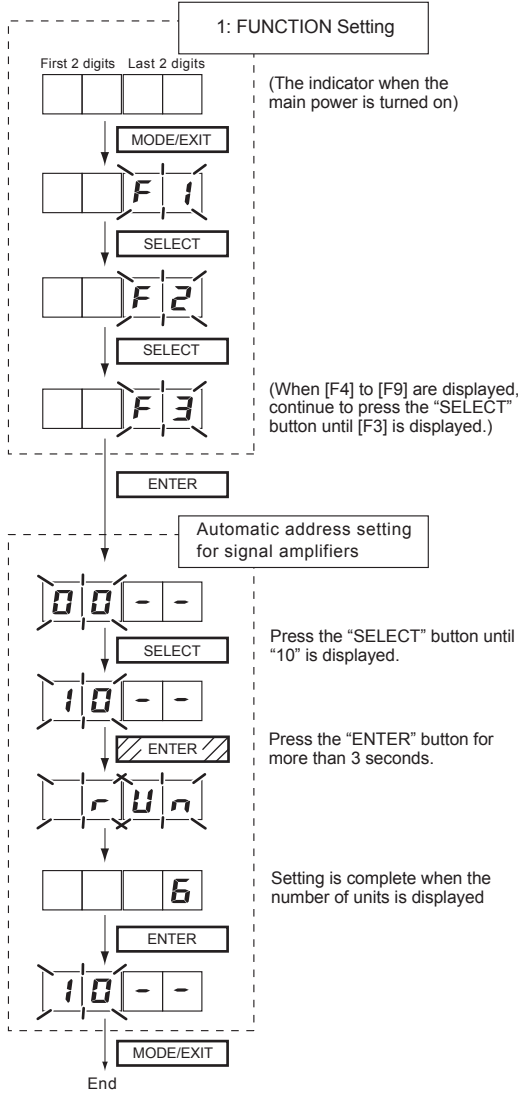

7.6. Indoor unit address setting

7.6.1. Indoor unit address setting

Address must be set for the indoor unit.

Manual setting → •When setting with the switch inside the indoor unit, refer to the indoor unit installation manual.

•When setting with a remote controller, refer to the remote controller installation manual.

Automatic setting → •Check that the wiring is as shown in the figure below.

Operate using the master outdoor unit of each refrigerant system.

Fig. Wiring example for automatic address setting

(1) Signal amplifier wiring example

(2)(3)(4) Indoor unit wiring example

(Connect the indoor and outdoor units of the same refrigerant system as shown below.)

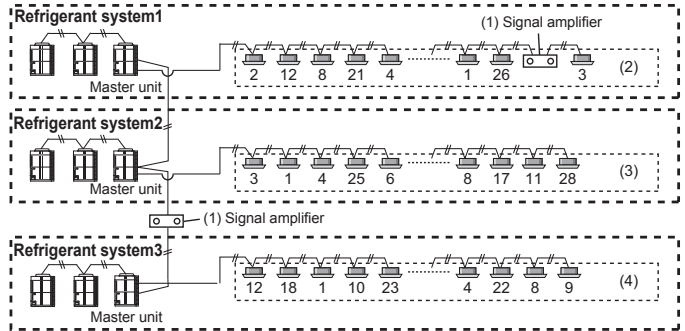

(NOTE)

- The automatic address function can be used for a maximum of 48 indoor units installed to the same refrigerant system. When network is connected to other refrigerant systems, the automatic address function cannot be used.
- The addresses of indoor units that have been configured automatically cannot be assigned in the order when they are installed. (Refer to the indoor unit installation manual for the procedures to check the addresses.)

7.6.2. Procedures to enable automatic address setting on indoor units

Check that the rotary switch IU AD on the indoor unit PC board is set to "00". If it is not set to "00", it means the address of that device is not set. (Factory default is "00").

Turn on the power of the indoor and outdoor units.

When the system is normal, nothing will be displayed on the 7 segment LED indicator.

When ERROR is displayed, inspect the units.

Use the "MODE/EXIT", "SELECT", and "ENTER" buttons on the outdoor unit PC board to configure settings according to the procedures below.

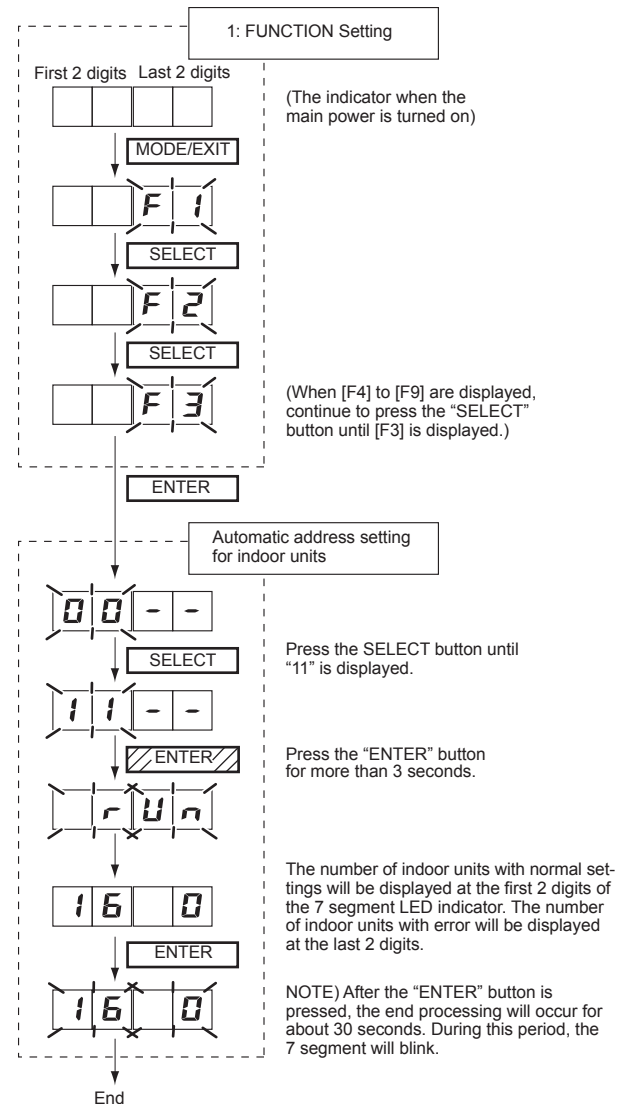

7.7. Resistance measurement of transmission cable (Measure with breaker OFF)

CAUTION

Do not turn on the power if the resistance between the terminals of the transmission cable is abnormal. Otherwise, the circuit board may be damaged.

Measure the resistance between 2 terminals of a transmission cable.

(1) Transmission cable connecting indoor units, outdoor units, and signal amplifiers

Measure the resistance of the signal amplifier terminal and the terminal of the indoor and outdoor units connected farthest away from the device where terminal resistor is measured.

A value from the table is displayed, depending on the distance from the signal amplifier and the device where the terminal resistor is set.

This value is an estimate.

(2) Transmission cable connecting outdoor units in a refrigerant system

The resistance between the terminals of the transmission cable is 45-60Ω. This value is an estimate.

| Approximate resistance (Ω) | Distance from termination resistor (m) | | | | |
|----------------------------|--|-------|-------|------|------|
| | 0 ~100 | ~ 200 | ~ 300 | ~400 | ~500 |
| 0 ~ 50 | A short circuit somewhere or 2 or more termination resistors are connected | | | | |
| 50 | █ | | | | |
| 60 | | █ | | | |
| 70 | | | █ | | |
| 80 | | | | █ | |
| 90 | | | | | █ |
| 100 | | | | | |
| 110 | | | | | |
| 120 | | | | | |
| 130 | | | | | |
| 140 | | | | | |
| 150 | | | | | |
| 160 | | | | | |
| 170 | | | | | |
| 180 | | | | | |
| 190 ~ | Faulty contact or wiring length over 500 m | | | | |
| 1K ~∞ | Faulty contact, open circuit, or no termination resistor | | | | |

8. PIPE INSTALLATION II

Fig. A Connection system

A) In case of connecting 1 outdoor unit

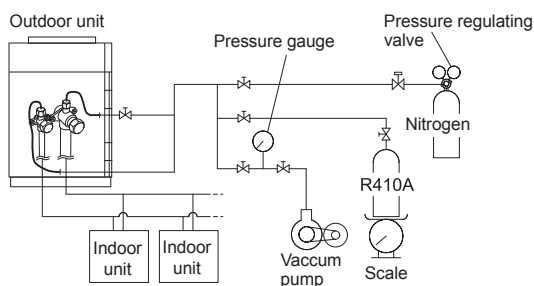

B) In case of connecting multiple outdoor units

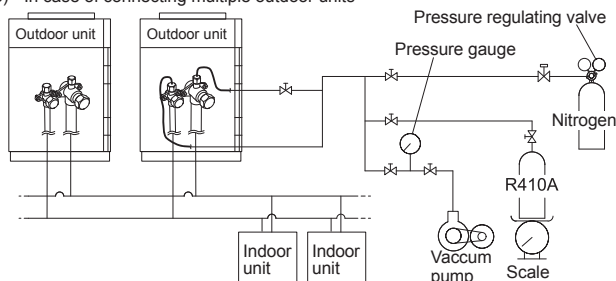

Fig. B

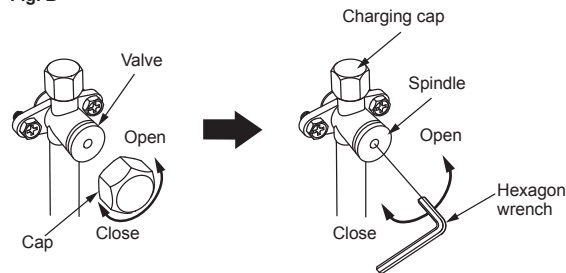

Table. A

| Valve type | Spindle | Cap | Charging cap |
|------------|---|---|---|
| Liquid | 9.0 to 12.0 N·m (90 to 120 kgf·cm) | 20.0 to 24.0 N·m (200 to 240 kgf·cm) | 12.5 to 16.0 N·m (125 to 160 kgf·cm) |
| Gas | 27.0 to 33.0 N·m (270 to 330 kgf·cm) | 25.0 to 30.0 N·m (250 to 300 kgf·cm) | 12.5 to 16.0 N·m (125 to 160 kgf·cm) |

8.1. Sealing test

CAUTION

- Use only nitrogen gas. Never use refrigerant gas, oxygen, in flammable gas or poisonous gas to pressurize the system. (If oxygen is used. There is danger of an explosion.)
- Do not shock during sealing test. It can rupture the pipes and cause serious injury.
- Do not turn on the power unless all operations are complete.
- Do not block the walls and the ceiling until the sealing test and charging of the refrigerant gas have been completed.

After connecting the pipes, perform a sealing test.

Recheck that the spindle of the 3-way valve are closed before performing a sealing test. (Fig. B)

Pour nitrogen gas through both the liquid pipe and the gas pipe. Pressurize nitrogen gas to 4.2 MPa to perform the sealing test.

Check all flare connection areas and brazed areas.

Then, check that the pressure has not decreased.

Compare the pressures after pressurizing and letting it stand for 24 hours, and check that the pressure did not decrease.

* When the outdoor temperature changes 5 °C, the test pressure changes 0.05 MPa.

If the pressure has dropped, the pipe joints may be leaking.

If a leakage is found, immediately repair it and perform a sealing test again.

* Decrease the pressure of nitrogen gas before brazing

After completing the sealing test, release the nitrogen gas from both valves. Release the nitrogen gas slowly.

8.2. Vacuum process

CAUTION

Do not turn on the power unless all operations are complete.

If the system is not evacuated properly, its performance will drop.

- If moisture enter the piping, follow below. (i.e., if doing work during the rainy season, if the actual work takes long enough that condensation may form on the inside of the pipes, if rain might enter the pipes during work, etc.)
- After operating the vacuum pump for 2 hours, pressurize to 0.05 MPa (i.e., vacuum breakdown) with nitrogen gas, then depressurize down to -100.7kPa (-755mmHg) for an hour using the vacuum pump (vacuum process).
- If the pressure does not reach -100.7kPa (-755mmHg) even after depressurizing for at least 2 hours, repeat the vacuum breakdown - vacuum process.

After vacuum process, maintain the vacuum for an hour and make sure the pressure does not rise by monitoring with a vacuum gauge.

Evacuation procedure

- Remove the caps of the gas pipe and liquid pipe and check that the valves are closed.
- Remove the charging cap.
- Connect a vacuum pump and a pressure gauge to a charging hose and connect it to the charging port.
- Activate the vacuum pump and vacuum the indoor unit and connection piping until the pressure gauge becomes -100.7kPa (-755mmHg). Evacuate from both the gas pipe and the liquid pipe.
- Continue evacuating the system for 1 hour after the pressure gauge reads -100.7kPa (-755mmHg).
- Remove the charging hose and reinstall the charging cap.

8.3. Additional charging

CAUTION

- Do not turn on the power unless all operations are complete.
- After evacuating the system, add refrigerant.
- Do not charge the system with a refrigerant other than R410A.
- Always keep to the limit on the total amount of refrigerant. Exceeding the limit on the total amount of refrigerant will lead to malfunction during charging of refrigerant.
- Do not reuse recovered refrigerant.
- Use an electronic scale to measure the charging amount of refrigerant. Adding more refrigerant than the specified amount will cause a malfunction.
- Charge refrigerant using the liquid pipe.
- Adding refrigerant through the gas pipe will cause a malfunction.
- Add refrigerant by charging the system with the refrigerant in the liquid state. If the refrigerant cylinder is equipped with a siphon, it is not necessary to place the cylinder upright.

8.3.1. Procedure for charging the system with refrigerant

- 1) Remove the charging cap from the liquid pipe. Use standard refrigeration practices when charging refrigerant.
- 2) Attach a charging hose to the refrigerant cylinder, and connect it to the charging port.
- 3) Add refrigerant by calculating the additional refrigerant volume in accordance with the calculation formula indicated below.
- 4) Remove the charging cap and install the charging hose.
- 5) Remove the body caps (gas pipe and liquid pipe), and open the valves.
- 6) Close the body caps.
- 7) After adding refrigerant, indicate the added charging volume on the unit.

* Tighten the body caps and charging caps to the torque values specified in the Table A.
To open and close the valves, Use an M4 hexagon wrench for liquid pipe.
Use an M10 hexagon wrench for gas pipe.

* * If you can not charge the specified amount of refrigerant with the above method, be sure to charge the refrigerant through the gas pipe while operating in cooling mode. In order to prevent liquid back-flow, carefully operate the refrigerant cylinder valve so that the refrigerant will flow in certain part at a time.

8.3.2. Checking total amount of refrigerant and calculating the amount of refrigerant charge to be added

- The amount of refrigerant charge to be added is the total value of the basic refrigerant charge amount and the value calculated from the length of the liquid pipe.
- Round up the value to 2 decimal places.

| Model | HP | d Factory charged amount (kg) | a Additional amount for outdoor unit (kg) |
|------------|------|----------------------------------|--|
| AJ□A72LALH | 8HP | 11.20 | 0 |
| AJ□A90LALH | 10HP | 11.20 | 0 |
| AJ□108LALH | 12HP | 11.80 | 1.20 |
| AJ□126LALH | 14HP | 11.80 | 3.30 |
| AJ□144LALH | 16HP | 11.80 | 3.30 |

| Diameter of liquid pipe (mm) | b Additional amount for pipe length (kg/m) |
|------------------------------|---|
| Ø6.35 | 0.021 |
| Ø9.52 | 0.058 |
| Ø12.70 | 0.114 |
| Ø15.88 | 0.178 |
| Ø19.05 | 0.268 |

(1) Calculation of additional amount for outdoor unit

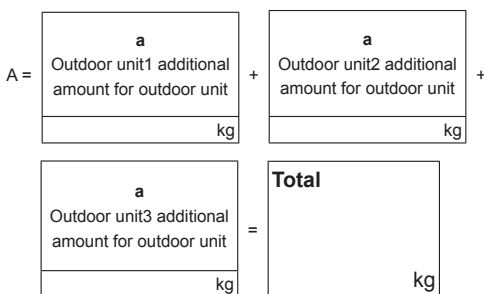

(2) Calculation of additional amount for pipe length

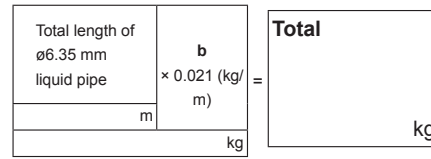
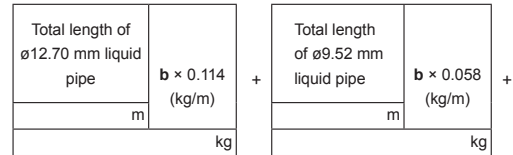
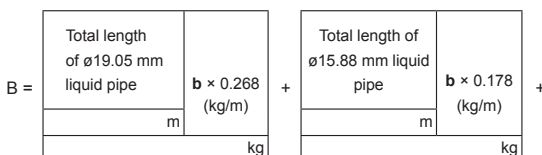

(3) Calculation of additional charge refrigerant

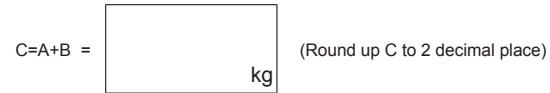

(4) Calculation of factory charged amount

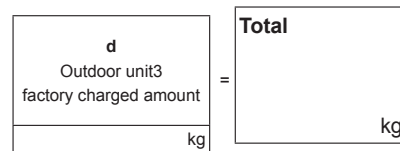
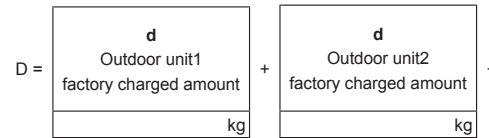

(5) Total refrigerant amount check



Note : Check the total refrigerant amount under the following conditions

| Condition | Computational formula |
|--|-----------------------|
| For 1 outdoor unit per refrigerant system : Total amount of refrigerant ≤ 31.5kg | E ≤ 31.5kg |
| For 2 outdoor units per refrigerant system : Total amount of refrigerant ≤ 63kg | E ≤ 63kg |
| For 3 outdoor units per refrigerant system : Total amount of refrigerant ≤ 94.5kg | E ≤ 94.5kg |

<Calculation>

- When there are 3 outdoor units (AJ□144LALH, AJ□126LALH, AJ□108LALH) connected to 1 system

(1) Calculation of additional amount for outdoor unit

$$A = 3.30 \text{ (kg)} + 3.30 \text{ (kg)} + 1.20 \text{ (kg)} = 7.80 \text{ (kg)}$$

(2) Calculation of additional amount for pipe length

If liquid pipe piping length is the following
 Ø19.05 : 50m, Ø15.88 : 25m, Ø12.70 : 0m, Ø9.52 : 20m, Ø6.53 : 15m
 Additional charge volume B = 50 (m) × 0.268 (kg/m) + 25 (m) × 0.178 (kg/m)
 + 0 (m) × 0.114 (kg/m) + 20 (m) × 0.058 (kg/m)
 + 15 (m) × 0.021 (kg/m)
 = 19.325kg

(3) Calculation of additional charge refrigerant
 C = A + B = 7.80 (kg) + 19.33 (kg) = 27.13 (kg)

(4) Calculation of factory charged amount
 D = 11.8 (kg) + 11.8 (kg) + 11.8 (kg) = 35.4 (kg)

(5) Check the total amount of refrigerant

When 3 outdoor units are connected to 1 system, the following condition must be satisfied.

Condition: E = C + D ≤ 94.5 (kg)

Calculation: 27.13 (kg) + 35.4 (kg) = 62.53 (kg) < 94.5 (kg)

→ No problem if the above condition is satisfied.

8.4. Installing insulation

- Install insulation material after conducting the "8.1 Sealing Test".
- To prevent condensation and water droplets, install insulation material on the refrigerant pipe.
- Refer to the table to determine the thickness of the insulation material.
- If the outdoor unit is installed at a level that is higher than the indoor unit, the water that has condensed in the 3-way valve of the outdoor unit could travel to the indoor unit. Therefore, use putty in the space between the pipe and the insulation to prevent the entry of water.

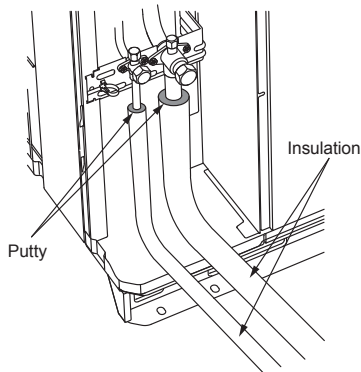

Table. Selection of insulation
(for using an insulation material with equal heat transmission rate or below 0.040W/(m·k))

| Relative humidity | Insulation material | | | | |
|--------------------|------------------------|-------|-------|-------|----|
| | Minimum thickness (mm) | | | | |
| | ≤ 70% | ≤ 75% | ≤ 80% | ≤ 85% | |
| Pipe diameter (mm) | 6.35 | 8 | 10 | 13 | 17 |
| | 9.52 | 9 | 11 | 14 | 18 |
| | 12.70 | 10 | 12 | 15 | 19 |
| | 15.88 | 10 | 12 | 16 | 20 |
| | 19.05 | 10 | 13 | 16 | 21 |
| | 22.22 | 11 | 13 | 17 | 22 |
| | 28.58 | 11 | 14 | 18 | 23 |
| | 34.92 | 11 | 14 | 18 | 24 |
| | 41.27 | 12 | 15 | 19 | 25 |

* When an ambient temperature and relative humidity exceed 32 °C, please strengthen heat insulation of refrigerant pipe.

9. TEST RUN

9.1. Pre-test run check items

Before the test operation, check the following items.

- ① Is there a gas leakage? (At pipe connections (flange connections and brazed areas))
- ② Is the system charged with the specified volume of refrigerant?
- ③ Is the refrigerant circuit address correct?
- ④ Is a breaker installed at the power supply cable of every outdoor unit?
- ⑤ Are the cables connected to the terminals without looseness, and in accordance with the specifications?
- ⑥ Are the initial settings of the switches of the outdoor unit correctly configured?
- ⑦ Is the 3-way valve of the outdoor unit open? (gas pipe and liquid pipe)
- ⑧ Is power supplied to the crank case heater for more than 12 hours? Electricity current in short period of time may result in compressor damage.
- ⑨ Are all the indoor units within the same coolant system connected to the power? Operating indoor units which are not connected to the power may result in malfunctions.



After checking that the above items are all in order, refer to "9.2 Test operation method" to test operation of the unit.
If there are problems, adjust immediately and recheck.

9.2. Test operation method

Be sure to configure test run settings only when the outdoor unit has stopped operating.

- Depending on the communication status between the indoor and outdoor units, it may take several minutes for the system to start operating after settings for the test run are complete.
- After the test run settings are complete, all the outdoor units and the connected indoor units will start operating. Room temperature control will not activate during test operation (continuous operation).
- If a knocking sound can be heard in the liquid compression of the compressor, stop the unit immediately and then energize the crank case heater for a sufficient length of time (more than 12 hours) before restarting the operation.

Perform test operation for each refrigerant system.

You can set "cooling test run" or "heating test run" with the push button on the outdoor unit PC board.

Test operation setting method

Use the "MODE/EXIT", "SELECT", and "ENTER" buttons on the outdoor unit PC board to configure settings according to the procedures below.

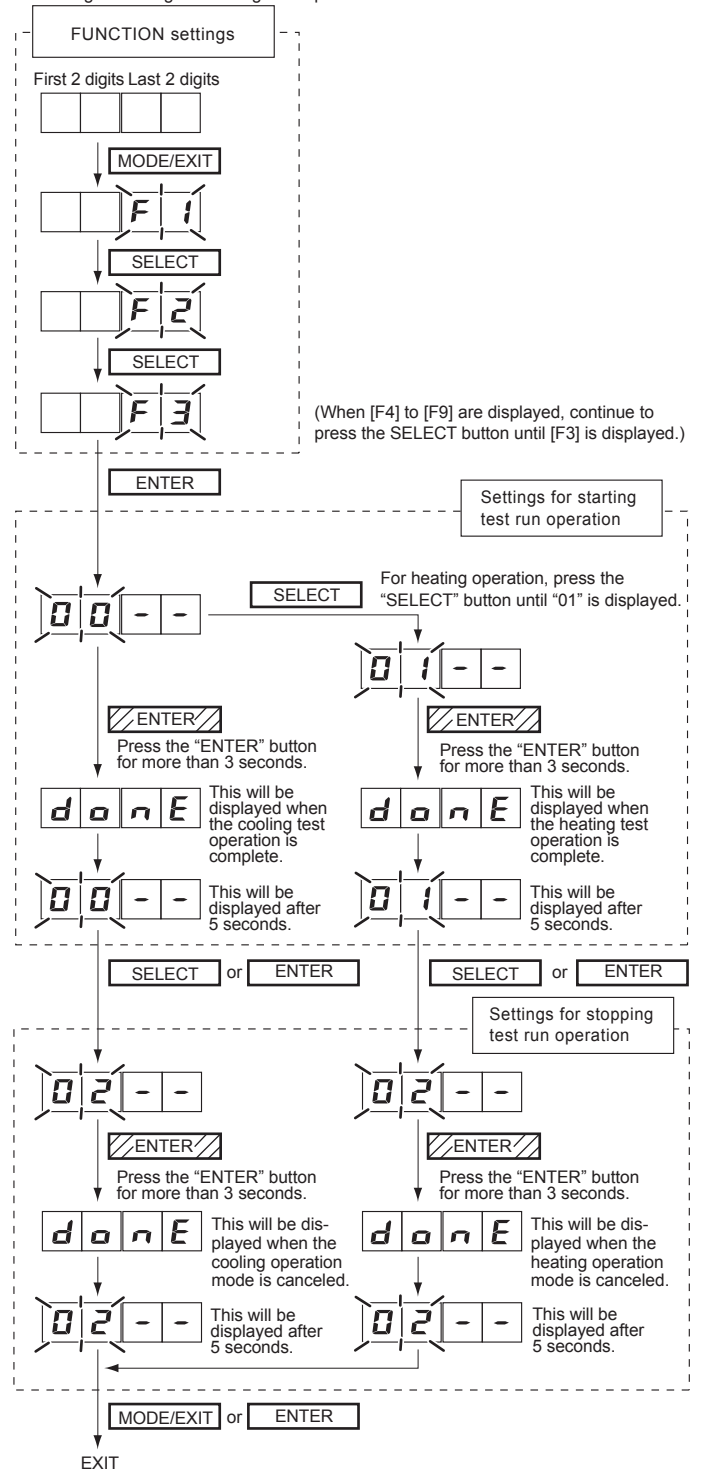

After the test operation is complete, turn off the power. Attach the cover of the electrical compartment box and the front panel of the outdoor unit.

Note

- Check that the indoor and outdoor units connected to the same refrigerant system are operating normally.
- When indoor or outdoor units are not operating, or when the indoor and outdoor units of other refrigerant systems are operating, the indoor/outdoor unit address or DIP switch for the number of connected slave units are not configured correctly.
- The system will not operate normally with an incorrect DIP switch setting. Stop the system immediately and recheck the DIP switch setting.

9.3. Checklist

| | Check description | Check method | Criteria |
|---|---|--|---|
| 1 | High and low pressure values are normal. | Check it with a pressure gauge. | Cooling: low pressure approx. 0.8 MPa Heating: high pressure approx. 3.0 MPa |
| 2 | Drain water is discharged smoothly through the drain hose. | Check it by pouring water. | — |
| 3 | Indoor and outdoor unit fans are operating. | Check them visually. | — |
| 4 | Compressor operates after the indoor unit operates. | Check the operating sound. | — |
| 5 | Difference between inlet and outlet temperatures is normal. | Measure the inlet and outlet temperatures. | Temperature difference 10 degrees |
| 6 | Error is not displayed | Check the 7 segment LED indicator | Error blinking or no error code display |

10. LED Status

You can determine the operating status by the lighting up and blinking of the 7 segment LED indicator.

Check the status using the table below.

10.1. Normal operation mode

| Mode | Code | Description |
|-----------|------|---------------------------------|
| Operation | C L | Cooling |
| | H t | Heating |
| | o r | During oil recovery operation |
| | d f | During defrosting operation |
| | P C | During peak cut operation |
| | L n | During low noise operation |
| | S n | During setting of snowfall mode |

10.2. Error codes

| Mode | Code | Description |
|---|---------------------------|---|
| Communication error | E 1 3. 1 | Communication error between outdoor units |
| | E 1 4. 1 | Outdoor unit network communication 1 error |
| | E 1 4. 2 | Outdoor unit network communication 2 error |
| | E 1 4. 5 | The number of indoor unit shortage |
| Function setting error | E 2 8. 1 | Auto address setting error |
| | E 2 8. 4 | Signal amplifier auto address error |
| Indoor unit actuator error | E 5 U. 1 | Indoor unit miscellaneous error |
| Outdoor unit PCB/Electrical component/ Switch error | E 6 1. 5 | Outdoor unit reverse/missing phase & wiring error |
| | E 6 2. 3 | Outdoor unit EEPROM access error |
| | E 6 2. 6 | Outdoor unit inverters communication error |
| | E 6 2. 8 | Outdoor unit EEPROM data corruption error |
| | E 6 3. 1 | Outdoor unit inverter error |
| | E 6 7. 2 | Outdoor unit inverter PCB power short interruption error |
| | E 6 8. 1 | Outdoor unit magnetic relay error |
| | E 6 8. 2 | Outdoor unit rush current limiting resistor temp. rise error (protective operation) |
| | E 6 9. 1 | Outdoor unit transmission PCB parallel communication error |
| | Outdoor unit sensor error | E 7 1. 1 |
| E 7 1. 2 | | Outdoor unit discharge temp. thermistor 2 error |
| E 7 2. 1 | | Outdoor unit compressor temp. thermistor 1 error |
| E 7 2. 2 | | Outdoor unit compressor temp. thermistor 2 error |
| E 7 3. 3 | | Outdoor unit heat ex. liquid temp. thermistor error |
| E 7 4. 1 | | Outside air temp. thermistor error |
| E 7 5. 1 | | Outdoor unit suction gas temp. thermistor error |
| E 7 7. 1 | | Outdoor unit heat sink temp. thermistor error |
| E 8 2. 1 | | Outdoor unit sub-cool heat ex. gas inlet temp. thermistor error |
| E 8 2. 2 | | Outdoor unit sub-cool heat ex. gas outlet temp. thermistor error |
| E 8 3. 1 | | Outdoor unit liquid pipe temp. thermistor 1 error |
| E 8 3. 2 | | Outdoor unit liquid pipe temp. thermistor 2 error |
| E 8 4. 1 | | Outdoor unit current sensor 1 error (permanent stop) |
| E 8 6. 1 | | Outdoor unit discharge pressure sensor error |
| E 8 6. 3 | | Outdoor unit suction pressure sensor error |
| E 8 6. 4 | | Outdoor unit high pressure switch 1 error |
| E 8 6. 5 | | Outdoor unit high pressure switch 2 error |

| | | |
|-----------------------------|--|--|
| Outdoor unit actuator error | E 9 2. 1 | Outdoor unit compressor 2 error |
| | E 9 2. 2 | Outdoor unit compressor 2 current value error |
| | E 9 3. 1 | Outdoor unit inverter compressor start up error |
| | E 9 4. 1 | Outdoor unit trip detection |
| | E 9 5. 5 | Outdoor unit compressor motor loss of synchronization |
| | E 9 7. 1 | Outdoor unit fan motor 1 lock error |
| | E 9 7. 4 | Outdoor unit fan motor 1 undervoltage error |
| | E 9 7. 5 | Outdoor unit fan motor 1 temperature error (protective action) |
| E 9 U. 2 | Outdoor slave unit error | |
| Refrigerant system error | E A 1. 1 | Outdoor unit discharge temperature 1 error (permanent stop) |
| | E A 2. 1 | Outdoor unit discharge temperature 2 error (permanent stop) |
| | E A 3. 1 | Outdoor unit compressor 1 temperature error |
| | E A 3. 2 | Outdoor unit compressor 2 temperature error |
| | E A 4. 1 | Outdoor unit high pressure error |
| | E A 4. 2 | Outdoor unit high pressure protective action 1 |
| | E A 4. 3 | Outdoor unit high pressure protective action 2 |
| | E A 5. 1 | Outdoor unit low pressure error |
| E A C. 4 | Outdoor unit heat sink temperature error | |

7 segment LED indicator:

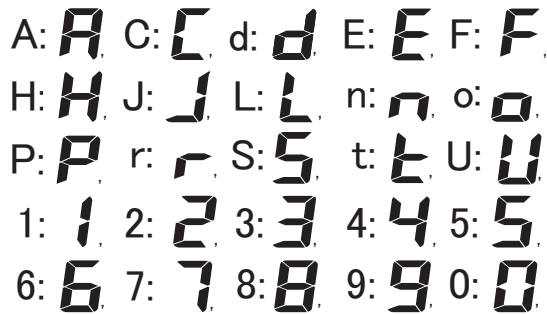

11. INFORMATION

Main contents of label

| Item | Detail |
|----------------------------------|---|
| 1. Model name | Model name |
| 2. Serial number | Serial number |
| 3. Electric characteristics | Phase, rated voltage, and frequency |
| 4. Weight | Product weight |
| 5. Capacity | Cooling/heating capacity under cooling/heating condition (refer to item 15) |
| 6. Current | Electric current during cooling/heating operation under cooling/heating condition (refer to item 15) |
| 7. Input power | Input during cooling/heating operation under cooling/heating condition (refer to item 15) |
| 8. Max. Current | Maximum electric current (temperature condition is max. cooling condition [refer to item 16]) |
| 9. Air circulation | Air circulation |
| 10. Noise level | Noise level |
| 11. Refrigerant | Refrigerant type and initial charging amount |
| 12. Max. pressure (HP/LP) | Means pressure of High Pressure side/ Low Pressure side |
| 13. Protection | Protection level against dust and water |
| 14. Working temperature | Working temperature |
| 15. Condition of cooling/heating | Dry-bulb temperature and wet-bulb temperature under standard cooling/heating condition |
| 16. Condition of max. cooling | Dry-bulb temperature and wet-bulb temperature at maximum electric current and input |
| 17. Manufacture year | Manufacture year |
| 18. Origin | Origin country |
| 19. Manufacturer | Manufacturer FUJITSU GENERAL LIMITED Address : 1116, Suenaga, Takatsu-ku, Kawasaki 213-8502, Japan |

