

AERIA 15 N/L

***instructions
for
installation***

*Document number: QSM000165E
Revision: “-”*

*Date of first issue: 10.05.04
Date of latest issue: 10.04.04*

COSTAN®

F3000

COSTAN TECHNICAL DOCUMENTATION	CHAPTER REVISION STATUS				DOC. N° QSM000165E	PAGE: 1/1
	ORD.	DATE	ORD.	DATE	N° CAP. 1	
PRODUCT: AERIA N/L 15 CHAPTER: TABLE OF CONTENTS	A		D		IN CONFORMITY WITH APPROVED ORIGINAL	DATE OF 1st ISSUE: 10.May.04
	B		E			
	C		F			

CHAP. No.	CHAPTER	NUMBER OF PAGES	REVISION STATUS
1	CONTENTS	1	"_"
2	SECTIONS	1	"_"
3	INSTALLATION DIAGRAMS	3	"_"
4	POSITION OF PROBES	1	"_"
5	REQUIRED HEAT EXTRACTION RATE	2	"_"
6	ELECTRICAL INPUT	1	"_"
7	THERMOSTATIC VALVE	2	"_"
8	CONTROLLER REGULATION	2	"_"
9	WIRING DIAGRAMS	19	"_"
10	MULTIPLEXING CABINETS	9	"_"

KEY

"_" First issue
A, B, C..... Chapter revision index

ORD.	DATE	ORD.	DATE
A		D	
B		E	
C		F	

CROSS-SECTIONS

AERIA N PLUS 15

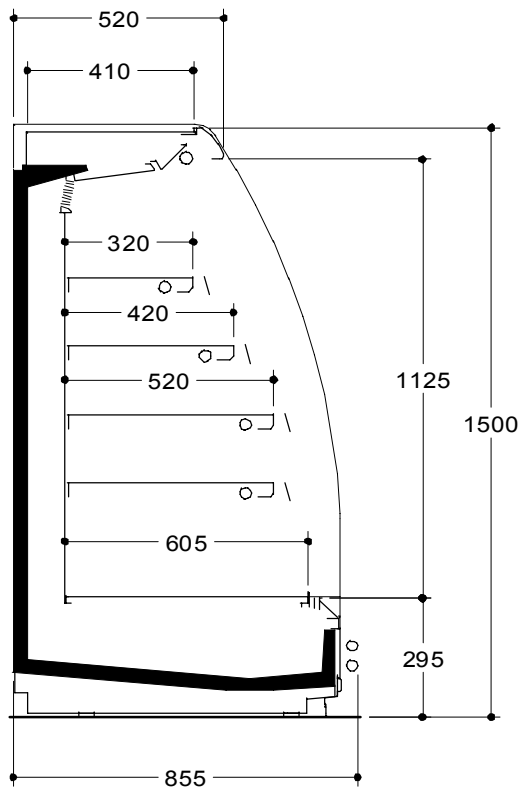

AERIA L PLUS 15

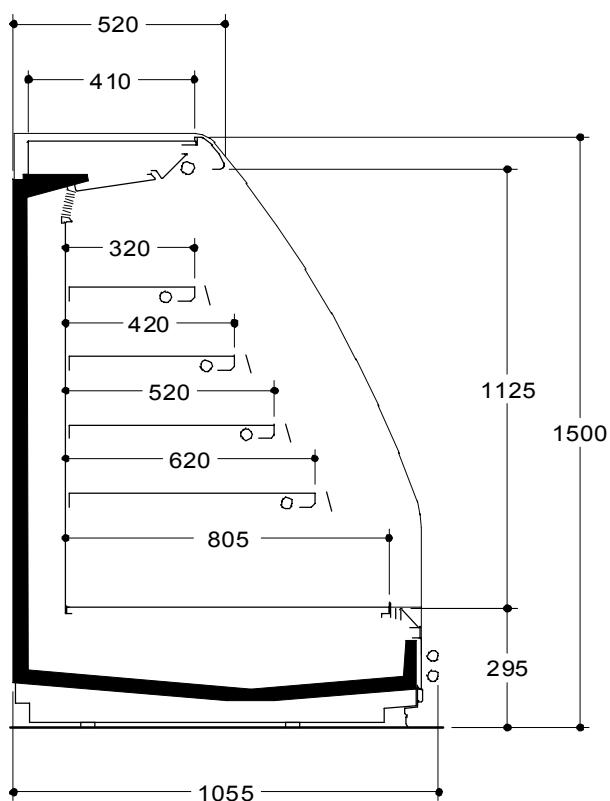

COSTAN TECHNICAL DOCUMENTATION	CHAPTER REVISION STATUS				DOC. N° QSM000165E N° CAP. 3	PAGE: 1/3
	ORD.	DATE	ORD.	DATE		
PRODUCT: AERIA N/L 15 CHAPTER: INSTALLATION DIAGRAMS	A		D		IN CONFORMITY WITH APPROVED ORIGINAL	DATE OF 1st ISSUE: 10.May.04
	B		E			
	C		F			

INSTALLATION DIAGRAMS

CROSS-SECTION OF WATER AND REFRIGERATING CONNECTIONS

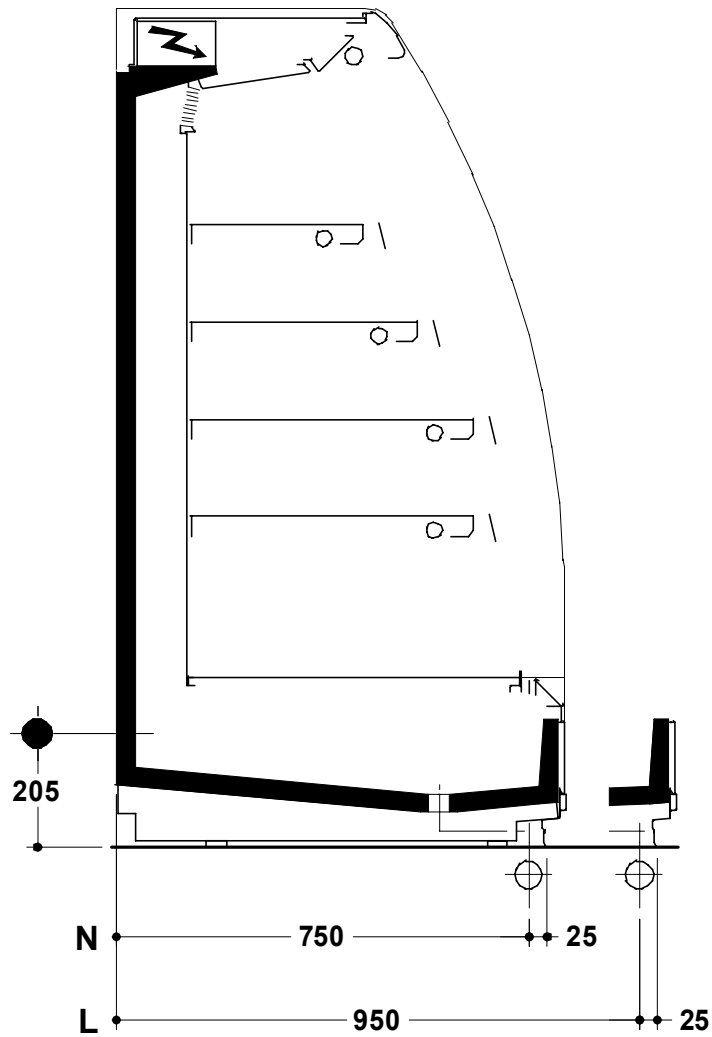

 water drain

 refrigerating connection

 electrical connection

ORD.	DATE	ORD.	DATE
A		D	
B		E	
C		F	

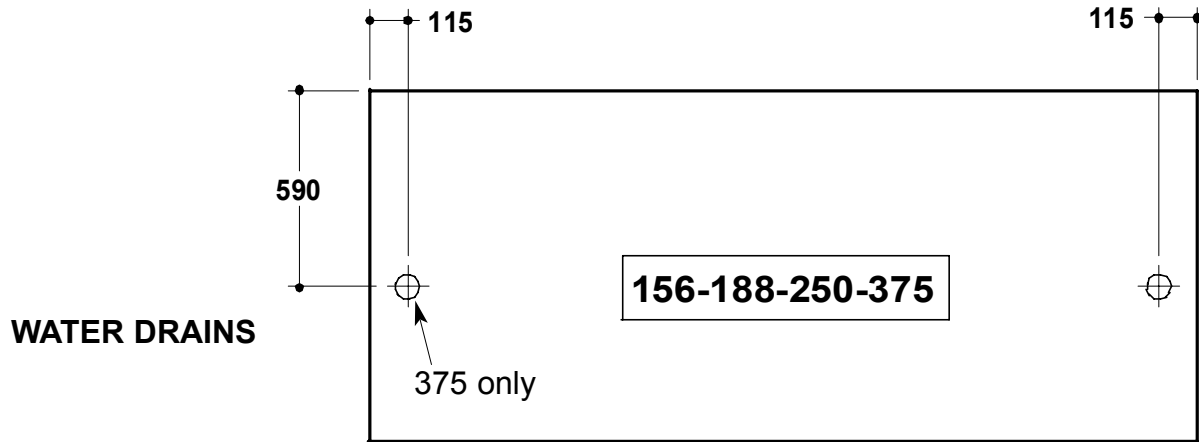

**REFRIGERATING
CONNECTION**

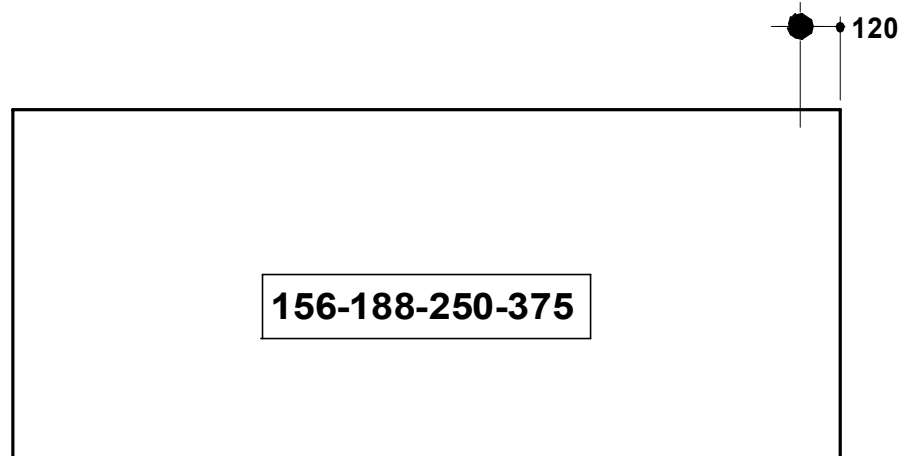

**ELECTRICAL
CONNECTION**

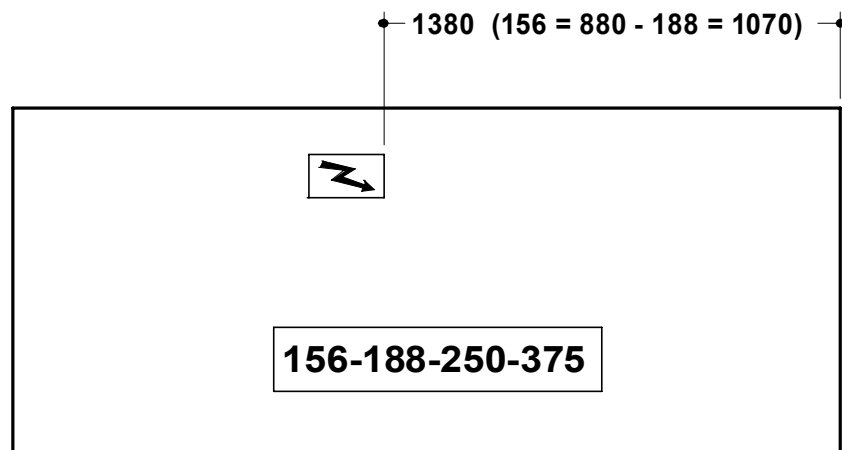

COSTAN ® TECHNICAL DOCUMENTATION	CHAPTER REVISION STATUS				DOC. N° QSM000165E N° CAP. 3	PAGE: 3/3
	ORD.	DATE	ORD.	DATE		
PRODUCT: AERIA N/L 15 CHAPTER: INSTALLATION DIAGRAMS	A		D		IN CONFORMITY WITH APPROVED ORIGINAL	DATE OF 1st ISSUE: 10.May.04
	B		E			
	C		F			

POSITION OF FEET

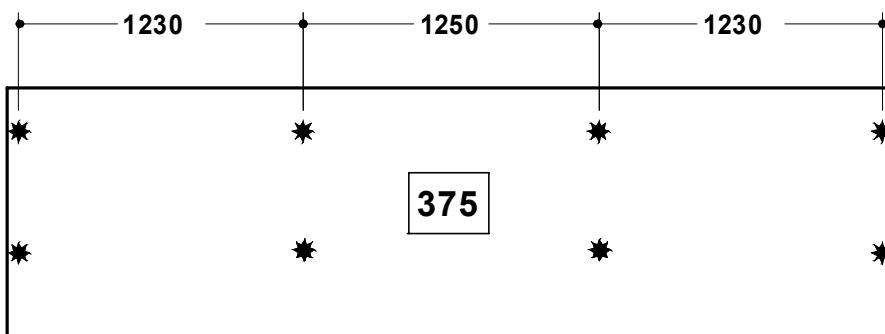
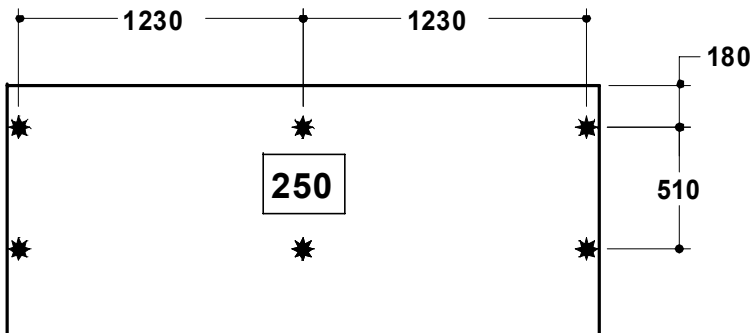
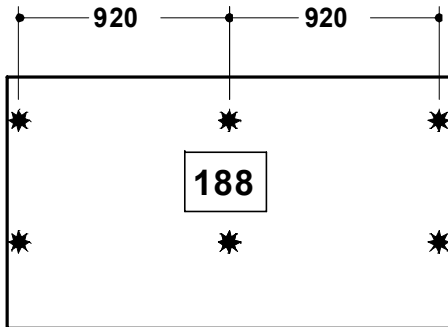
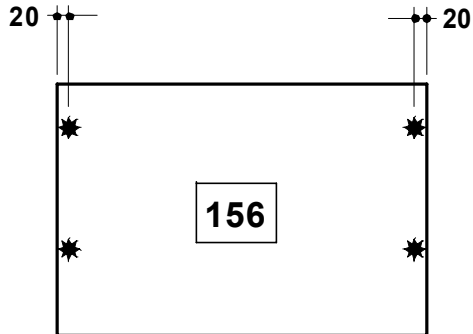

COSTAN TECHNICAL DOCUMENTATION	CHAPTER REVISION STATUS				DOC. N° QSM000165E	PAGE: 1/1
	ORD.	DATE	ORD.	DATE		
PRODUCT: AERIA N/L 15 CHAPTER: POSITION OF PROBES - VALVE - CONTROLLER	A		D		N° CAP. 4 IN CONFORMITY WITH APPROVED ORIGINAL	DATE OF 1st ISSUE: 10.May.04
	B		E			
	C		F			

POSITION OF PROBES - THERMOSTATIC VALVE - CONTROLLER

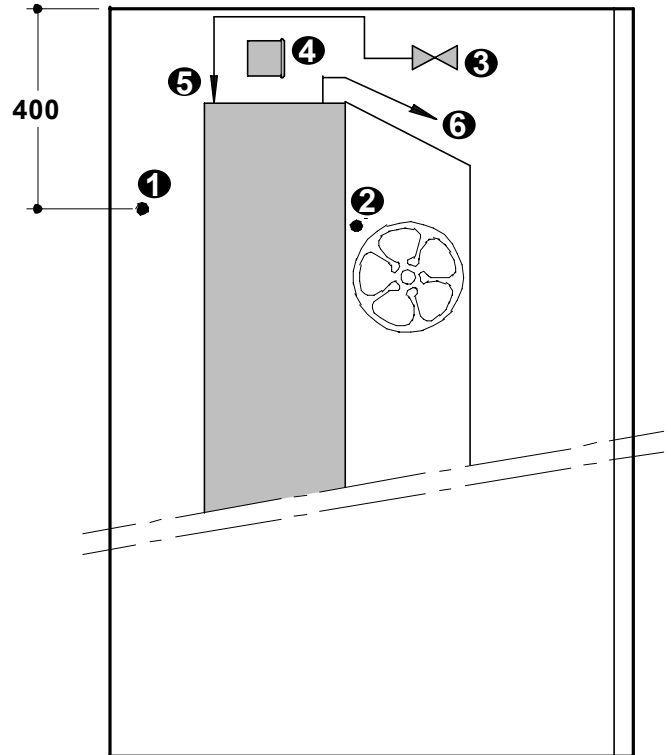
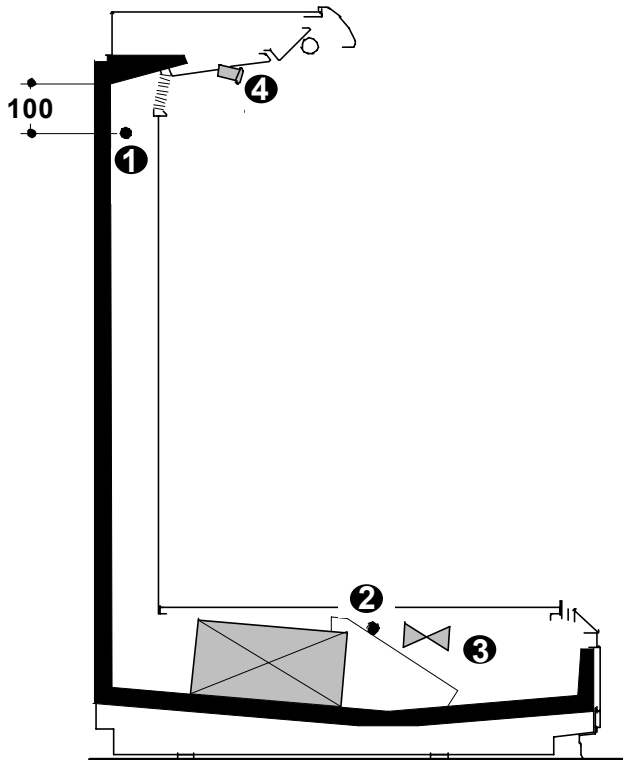

- ❶ discharge probe
- ❷ air inlet probe
- ❸ thermostatic valve
- ❹ controller
- ❺ way in of evaporator piping
- ❻ way out of evaporator piping

Ø DISCHARGE/SUCTION PIPING

FREON

Ø Suction line = 18 mm (L156 = 15 mm)

Ø Discharge line with thermostatic valve = 10 mm
without thermostatic valve = 12 mm

GLYCOL

Ø = 28 mm

COSTAN TECHNICAL DOCUMENTATION	CHAPTER REVISION STATUS				DOC. N° QSM000165E	PAGE: 1/2
	ORD.	DATE	ORD.	DATE		
PRODUCT: AERIA NIL 15 CHAPTER: REQUIRED HEAT EXTRACTION RATE	A		D		N° CHAP. 5 IN CONFORMITY WITH APPROVED ORIGINAL	DATE OF 1st ISSUE: 10.May.04
	B		E			
	C		F			

REQUIRED HEAT EXTRACTION RATE - ADJUSTMENT

prEN 441-1 prEN 441-2 : 2001

CLASS 3: 25° C - 60% RH

M	C	IF	T _o °C	Φ _o (W)					
						MT156	MT188	MT250	
				W/m		156	188	250	375
AERIA N	3M2	HNLS	-7	1475		2300	2775	3690	5530
	3H1	HNLS	-3	1340		2090	2520	3350	5025
	3H1	TNLS	-3	1160		1810	2180	2900	4350
AERIA L	3M2	HNLS	-8	1555		2425	2925	3890	5830
	3H1	HNLS	-4	1405		2190	2640	3515	5270
	3H1	TNLS	-4	1220		1905	2295	3050	4575

S.L.C.								
M	C	IF	Ctrl		Def			
			Ci °C	Co °C	Type	N/24 h	T ^{°ter} °C	t _d min
AERIA N	3M2	HNLS	0	-1	Nat	6	10	20
	3H1	HNLS	3	2		6	10	15
	3H1	TNLS	3	2		6	10	15
AERIA L	3M2	HNLS	0	-1		6	10	20
	3H1	HNLS	2	1		6	10	15
	3H1	TNLS	2	1		6	10	15

COSTAN TECHNICAL DOCUMENTATION	CHAPTER REVISION STATUS				DOC. N°	PAGE: 2/2
	ORD.	DATE	ORD.	DATE	QSM000165E	
PRODUCT: AERIA N/L 15 CHAPTER: REQUIRED HEAT EXTRACTION RATE	A		D		N° CAP. 5	DATE OF 1st ISSUE: 10.May.04
	B		E		IN CONFORMITY WITH APPROVED ORIGINAL	
	C		F			

HEAT EXTRACTION RATE VARIATION DEPENDING ON THE ENVIRONMENT

CLASSE	Temperature	Relative humidity	Correction factor	Correction of evaporating temperature
	°C	%	Φ_o	T_o
2	22	65	(Φ_o CLA 3) x 0,88	(T_o CLA 3) + 1,5 °C
3	25	60	Reference	Reference
4	30	55	(Φ_o CLA 3) x 1,22	(T_o CLA 3) - 2,5 °C
6	27	70		

* These correction factors apply to cabinets fitted with non-lighted shelves.

For each row of lighted shelves, add to Φ_o : + 30 W/m and -0,5 °C to evaporating temperature, provided it does not drop below -10 °C.

DEFROST SAFETY TEMPERATURE

	Safety time in minutes
Off cycle defrost	45
Electric defrost	20

CONTROL				
C	Alarm outside the defrost period			Maximum air temperature on resuming operation after defrosting
	Threshold	Timer	Exception period after defrosting	
	°C	min	min	°C
3M2	+4	10	35	+8
3H	+6	10	35	+10

COSTAN TECHNICAL DOCUMENTATION	CHAPTER REVISION STATUS				DOC. N° QSM000165E N° CAP. 6	PAGE: 1/1
	ORD.	DATE	ORD.	DATE		
PRODUCT: AERIA N/L 15 CHAPTER: ELECTRICAL INPUT	A		D		IN CONFORMITY WITH APPROVED ORIGINAL	DATE OF 1st ISSUE: 10.May.04
	B		E			
	C		F			

ELECTRICAL INPUT

Voltage: 230 V single-phase 50 hz

Output (wattage): W (Watt)

Intensity (amperage): A (Ampere)

(1) Lighting (per row of lamps - standard ballast)

(2) Standard power-factor improved lighting: $0,9 < \cos \Phi < 1$

	L	STANDARD									OPTION					
		Fans			Demist heaters			Canopy lighting (1)			Defrost heaters			Shelf lighting (1)		
		NB	W	A	NB	W	A	NB	W	A(2)	NB	W	A	NB	W	A(2)
AERIA N/L PLUS 15	TG 156	2	76	0,46	1	21	0,09	1	46	0,21	1	1060	4,6	1	46	0,21
	TG / 188	2	76	0,46	1	31	0,13	2	92	0,42	1	1280	5,6	2	92	0,42
	TG / 250	3	114	0,69	1	41	0,18	2	92	0,42	1	1700	7,4	2	92	0,42
	375	4	152	0,92	1	61	0,27	3	138	0,63	1	2550	11,1	3	138	0,63

COSTAN TECHNICAL DOCUMENTATION	CHAPTER REVISION STATUS				DOC. N°	PAGE: 1/2
	ORD.	DATE	ORD.	DATE	QSM000165E	
PRODUCT: AERIA N/L 15	A		D		N° CAP. 7	DATE OF 1st ISSUE: 10.May.04
CHAPTER: THERMOSTATIC VALVE FEATURES	B		E		IN CONFORMITY WITH APPROVED ORIGINAL	
	C		F			

THERMOSTATIC VALVE FEATURES

FEATURES OF DANFOSS THERMOSTATIC VALVE RANGE N - WITHOUT MOP - ADAPTOR FITTING TO BE SOLDERED

Selection rules:

- effective heat extraction rate and evaporating temperature at lab conditions (25 °C 60% R.H. class 3);
- condensing pressure equivalent to a temperature of +35°C;
- undercooling 10 K.

		R404A	
		Range	
M	L	Type	Nozzle
AERIA N	TG 156	TS2	02
	TG / 188		02
	TG / 250		03
	375		04
AERIA L	TG 156	TS2	02
	TG / 188		03
	TG / 250		03
	375		04

Refrigerating details refer to cabinets with thermostatic valves set to provide an undercooling value of 5K.

COSTAN TECHNICAL DOCUMENTATION	CHAPTER REVISION STATUS				DOC. N°	PAGE: 2/2
	ORD.	DATE	ORD.	DATE	QSM000165E	
PRODUCT: AERIA NIL 15	A		D		N° CAP 7	DATE OF 1st ISSUE: 10.May.04
CHAPTER: THERMOSTATIC VALVE FEATURES	B		E		IN CONFORMITY WITH APPROVED ORIGINAL	
	C		F			

FEATURES OF DANFOSS THERMOSTATIC VALVE

Selection rules:

- effective heat extraction rate and evaporating temperature at lab conditions (25 °C 60% R.H. class 3);
- condensing pressure equivalent to a temperature of +35°C;
- undercooling 4 K
- considering overcapacity as 25% and valve opening between 50 and 75%, maximum DANFOSS recommended values.

				R404A
M	L	Type	Nozzle	
AERIA N	156TG	AKV 10	4	
	188 / 188TG		4	
	250 / 250TG		5	
	375		6	
AERIA L	156		4	
	188 / 188TG		5	
	250		5	
	375		6	

Refrigerating details refer to cabinets with thermostatic valves set to provide an undercooling value of 5K.

COSTAN TECHNICAL DOCUMENTATION PRODUCT: AERIA N/L 15 CHAPTER: CONTROLLER SETTINGS	CHAPTER REVISION STATUS				DOC. N°	PAGE: 1/2
	ORD.	DATE	ORD.	DATE	QSM000165E	
	A		D		N° CAP. 8	
	B		E		IN CONFORMITY WITH APPROVED ORIGINAL	
	C		F		DATE OF 1st ISSUE: 10.May.04	

SETTINGS FOR CONTROLLER EKC201				
Parameter function	Parameters of Danfoss controller	Min. value of Danfoss controller	Max. value of Danfoss controller	AERIA PLUS
1. Cutout T° for S4 / Sout *	OUT	-50°C	50°C	-1
2. Cutout T° for S3 / Sin *	In	-50°C	50°C	3
Thermostat parameters				
1. Temperature unit (°C/°F)	r05	°C	°F	°C
2. S4 / Sout differential (r07 = Sout cut-in T° * - cut-out T°)	r07	0.1 K	20 K	1
3. S3 / Sin differential (r08 = cut-in T° * - cut-out T° Sin)	r08	0.1 K	20 K	20
4. Correction of signal from S4/Sout	r09	-20.0 K	20.0 K	0
5. Correction of signal from S3/Sin	r10	-20.0 K	20.0 K	0
Alarm parameters				
1. Timing of temperature alarm *	A03	0	90 mn	10
2. Upper limit exceeded S4/Sout (A05 =threshold * - cut-out T° of Sout)	A05	0 K	50 K	6
3. Lower limit of S4/Sout exceeded	A06	-50 K	0 K	-50
4. Upper limit of S3/Sout exceeded (A07 =threshold * - cut-out T° of Sin)	A07	0 K	50 K	50
5. Lower limit of S3/Sin exceeded	A08	-50 K	0 K	-50
6. S3/Sin alarm time-lag with night covers	A09	-50 K	50 K	0
VEM Parameters				
1. Min. ON-time	c01	0 min	15 min	0
2. Gap between two defrosts	c02	0 min	15 min	0
3. Cut-in frequency in case of probe fault	c03	0%	100%	100
Defrost parameters				
1. Compressor On when under defrosting	d01	No	Yes	No
2. Defrost-end T° * (probe selection automatic according to d10)	d02	0	25 °C	10
3. Gap between 2 defrosts (d03=24 / n° of defrosts per day*)	d03	OFF	48 h	4
4. Safety time *	d04	0	180 min	45
5. Defrost signal time-lag after start-up	d05	0	60 min	0
6. Drip off time	d06	0	20 min	0
7. Timing of fan start on defrost end	d07	0	20 min	0
8. Fan start temperature (>25°C=OFF)	d08	-25	26°C	OFF
9. Fan operation when under defrosting (yes/no)	d09	No	Yes	Yes
10. Defrost probe	d10	OUT	DEF	OUT
11. Alarm delay on defrost end *	d11	0	200 min	35
12. Delay of display view after defrost end	d12	0	30 min	0
13. Defrost on start-up	d13	No	Yes	No
1. Defrost start, hour				
1. Real time clock parameters	t01	OFF	23 h	Value to be defined at the time of installation only for controllers Danfoss model S or S/C
2. 1. Defrost start, minutes	t11	0	59 min	
3. 2. Defrost start, hour	t02	OFF	23 h	
4. 2. Defrost start, minutes	t12	0	59 min	
5. 3. Defrost start, hour	t03	OFF	23 h	
6. 3. Defrost start, minutes	t13	0	59 min	
7. 4. Defrost start, hour	t04	OFF	23 h	
8. 4. Defrost start, minutes	t14	0	59 min	
9. 5. Defrost start, hour	t05	OFF	23 h	
10. 5. Defrost start, minutes	t15	0	59 min	
11. 6. Defrost start, hour	t06	OFF	23 h	
12. 6. Defrost start, minutes	t16	0	59 min	
13. Adjustment of hour	t07	0	23 h	
14. Adjustment of minutes	t08	0	59 min	
Ventilation parameters				
1. Fans off when compressors are off	F01	No	Yes	No
2. Fan off time	F02	0	15 min	0
Other parameters				
1. Output delay on startup	o01	0	600 sec	0
2. Digital input signals	o02	OFF	5	Values to be defined at the time of installation
3. Network address (from 0 to 60)	o03	0	990	
4. LON service connector	o04	OFF	100	
5. Access code	o05	OFF	100	
6. Type of probe used (Pt/PTC)	o06	Pt	PTC	Pt / PTC
7. Synchronised defrost with pilot	o13	OFF	2	Value to be defined at the time of installation only for controllers Danfoss model S or S/C
8. Selection of regulation probe	o14	Aut	Out	Out
9. Temperature display scale	o15	No	Yes	Yes
10. Max wait time after synchronized defrost	o16	1	30 min	30
11. Selection of display probe signal	o17	Aut	In	In
12. Manual output command	o18	OFF	5	OFF
* Parameters to be adapted to the climatic class required by the foods in question				

ORD.	DATE	ORD.	DATE
A		D	
B		E	
C		F	

SETTINGS FOR CONTROLLER EKC414

Function	Parameter	MIN	MAX	AERIA PLUS
Thermostat				
Set point •				
1 Differential	r01	0.1K	10.0K	-1
2 Max. limitation of thermostat setpoint	r02	-49°C	50°C	2
3 Min. limitation of thermostat setpoint	r03	-50°C	49°C	-5
4 Temperature unit	r05	°C	°F	°C
5 Correction of the signal from S4 (S _{out})	r09	-10.0K	10.0K	0
6 Correction of the signal from S3 (S _{in})	r10	-10.0K	10.0K	0
7 Main switch for the controller	r12	OFF	ON	ON
8 Night Offset	r13	-20.0K	20.0K	0
9 Thermostat mode 1 = ON/OFF, 2 = Modulating	r14	1	2	1
10 Weighting of sensors for thermostat 100%=S4 (S _{out}), 0%=S3 (S _{in})	r15	0%	100%	100
11 Time between melt periods	r16	0 h	10 h	0
12 Melt period	r17	0 min	10 min	0
Alarm				
1 Delay for temperature alarm	A03	0 min	120 min	10
2 Delay for door alarm	A04	0 min	90 min	90
3 Delay for Pulldown	A12	0 min	240 min	60
4 High temperature limit •	A13	-50°C	50°C	4
5 Low temperature limit	A14	-50°C	50°C	-50
Compressor function				
1 Min. ON-time	c01	0 min.	50 min.	0
2 Min. OFF-time	c02	0 min.	50 min.	0
Defrost				
1 Defrost stop temperature	d02	0	25°C	10
2 Interval between defrost starts •	d03	OFF	48 h	4
3 Max. defrost duration	d04	0	180 min	45
4 Defrost time delay after power up	d05	0	240 min	0
5 Drip-off time	d06	0	60 min	0
6 Delay for fan start after defrost	d07	0	60 min	0
7 Fan start temperature	d08	-15	0°C	0
8 Fan cut in during defrost (yes/no)	d09	No	Yes	No
9 Defrost sensor 0=S4 (S _{out}), 1=S5 (S _{def}), 2=none i.e. stop on time	d10	0	2	0
10 Defrost start at power up	d13	no	yes	No
Realtime clock				
1 Defrost start. Hours	t01	OFF	23hours	Values to be specified at the time of installation for Danfoss Control models S or S/C
2 Defrost start. Minutes	t11	0	59 min	
3 Defrost start. Hours	t02	OFF	23hours	
4 Defrost start. Minutes	t12	0	59 min	
5 Defrost start. Hours	t03	OFF	23hours	
6 Defrost start. Minutes	t13	0	59 min	
7 Defrost start. Hours	t04	OFF	23hours	
8 Defrost start. Minutes	t14	0	59 min	
9 Defrost start. Hours	t05	OFF	23hours	
10 Defrost start. Minutes	t15	0	59 min	
11 Defrost start. Hours	t06	OFF	23hours	
12 Defrost start. Minutes	t16	0	59 min	
13 Setting of Hours	t07	0	23hours	
14 Setting of Minutes	t08	0	59 min	
15 Start time day operation (0=constant day)	t17	0	23	
16 Start time night operation (0=constant day)	t18	0	23	
Injection control				
1 Max. limitation of superheat reference	n09	3.0 K	15.0 K	6
2 Min. limitation of superheat reference	n10	3.0 K	10.0 K	4
3 MOP Temperature	n11	-50.0°C	15°C/off	off
5 Period time AKV pulsing	n13	3 sec.	6 sec.	6
10 Stability	n18	0	10	4
11 Forced closing ON = Akv closed	n36	OFF	ON	OFF
Fan control				
1 Fan stop on compressor cut out	F01	No	Yes	No
2 Delay for fan stop when compressor cuts out	F02	0 min	30 min	0
3 Temperature limit for fan stopped via S5 (S _{def}) value	F04	-50.0	50.0/off	OFF
Miscellaneous				
1 Delay of output signal after start up	o01	0 sec	600 sec	0
2 DI control OFF=not used, 1=door alarm, 2=Defrost start, 3=Night, 4=Main switch, 5=Slave defrost	o02	OFF	5	Values to be specified at the time of installation
3 Network address	o03	0	990	
4 ON/OFF Switch (service-pin message)	o04	OFF	ON	
5 Access code	o05	OFF	100	
6 Used sensor type (Pt/PTC)	o06	Pt	PTC	Pt/PTC
7 Language 0=English, 1=German, 2=French, 3=Danish, 4=Spanish, 5=Italian	o11	0	5	0
7 50/60 Hz	o12	50	60	50
8 DO output controls OFF=not used, 1=Def. Master, 2=Def. Slave	o13	0	2	Values to be specified at the time of installation for Danfoss Control models S or S/C
10 Display step no=0.1, yes =0.5	o15	no	yes	yes
11 Max. standby time after defrost	o16	1 min	30 min	30
12 Display S4 % (S _{out}) 0%=S3 (S _{in}) 100%=S4 (S _{out})	o17	0%	100%	0
13 Manual control of output via EKC	o18	OFF	7	OFF
14 Pressure Min. Value	o20	-1 bar	5 bar	-1
15 Pressure Max. Value	o21	6 bar	36 bar	12
16 ON input control	o29	1	4	1
17 Refrigerant setting • ONLY for the use of R404A. WARNING : Wrong selection of refrigerant may cause damage to the compressor.	o30	0	30	19
Service				
1 u09 ... u26				read only

• Parameters have to be adapted according to the food temperature class or the ambient class or the refrigerant use.

COSTAN TECHNICAL DOCUMENTATION	CHAPTER REVISION STATUS				DOC. N° QSM000165E	PAGE: 1/19
	ORD.	DATE	ORD.	DATE	CHAP. N° 9	
PRODUCT: AERIA N/L 15 CHAPTER: WIRING DIAGRAMS	A		D		IN CONFORMITY WITH APPROVED ORIGINAL	DATE OF 1st ISSUE: 10.May.04
	B		E			
	C		F			

WIRING DIAGRAMS

GENERAL KEY

- Q1 Circuit breaker
- Q2 Lights cutoff
- Q3 Cutoff
- K1 Lights contactor
- XA Fans
- XB Electric defrosting (optional)
- XD Lighting
- XE Adjustment
- XF VEM
- XG Lights switch
- XH Relay 24V to control lighting (optional)
- XJ Relay to control the 2° air curtain

WIRING DIAGRAMS: READING PRINCIPLE

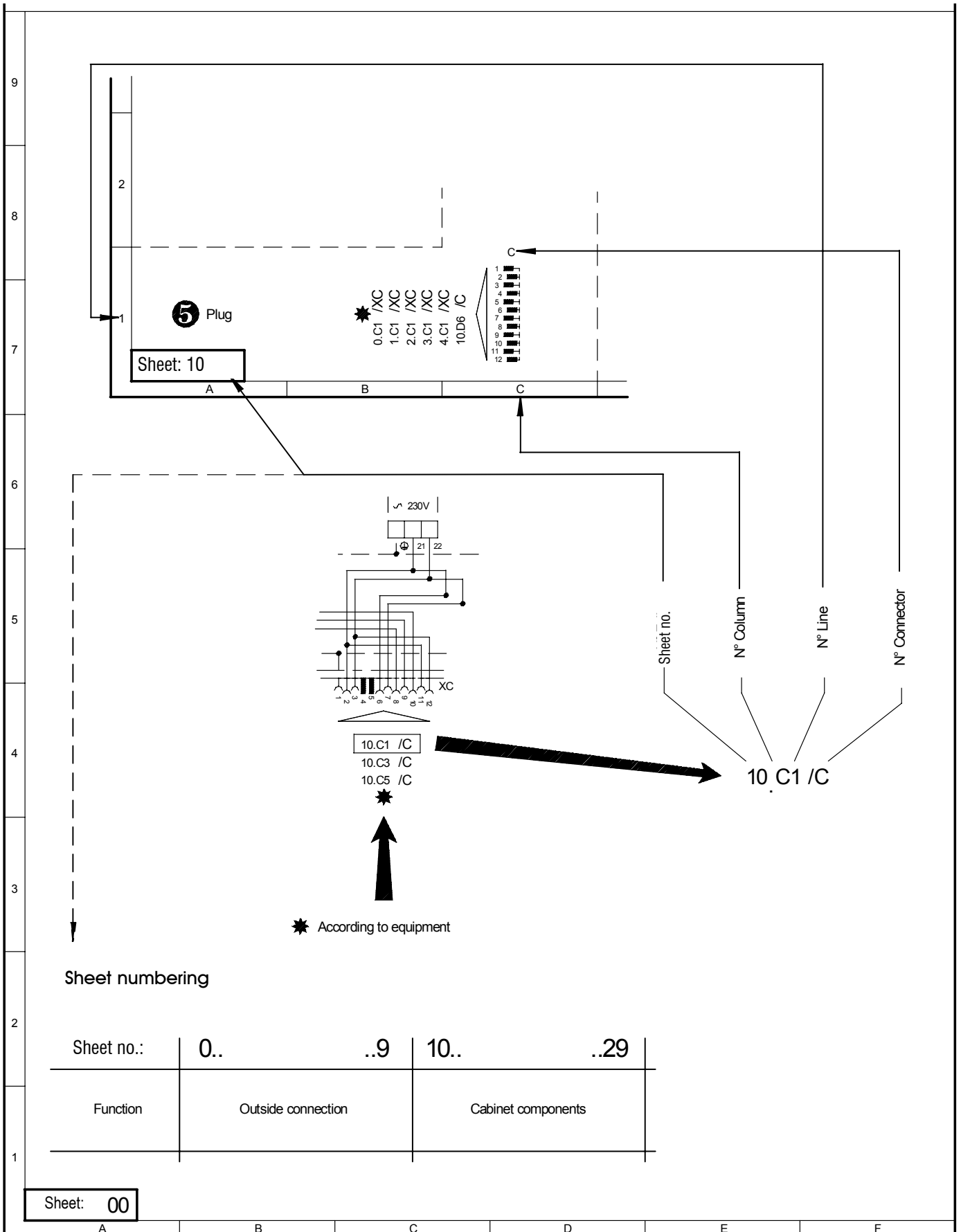

ORD.	DATE	ORD.	DATE
A		D	
B		E	
C		F	

WIRING DIAGRAM: CABINET TERMINAL-STRIP

* According to equipment

1 Lights power supply

5 Fan + controller power supply

3 Demist heater and/or second air-curtain power supply

6 Solenoid valve

7 Alarm clean contact

4 Defrost heater power supply *

8 Defrost start signal

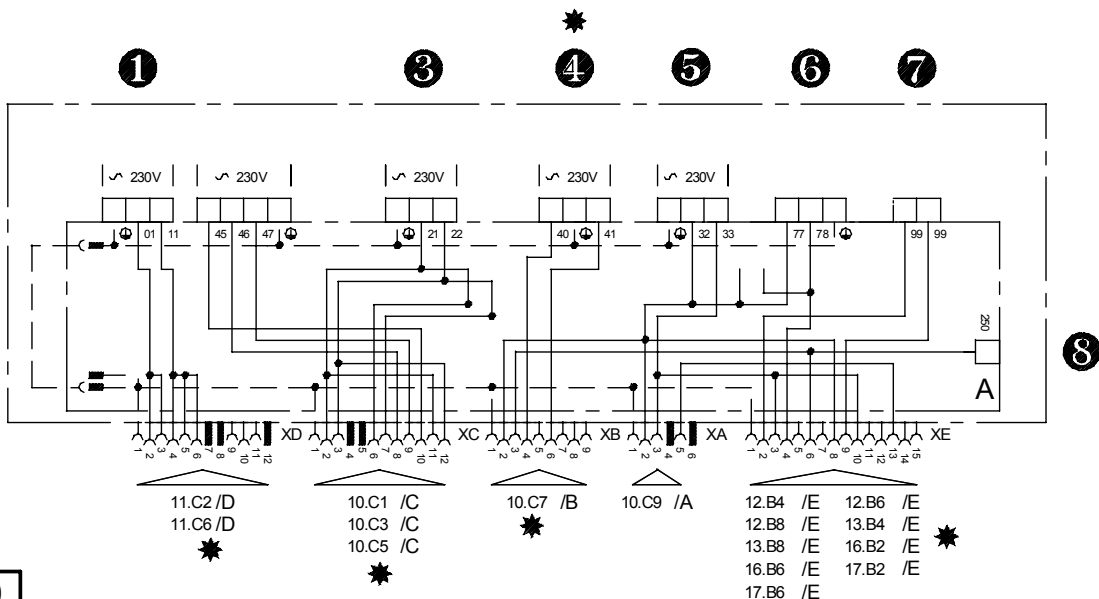

ORD.	DATE	ORD.	DATE
A		D	
B		E	
C		F	

WIRING DIAGRAM SRTS 3 (400V)
(Safety run terminal-strip for 3 cabinets)

★ According to equipment

- ❶ Light Remote Control signal 24V AC
- ❸ Defrost start signal (250)
- ❺ Thermostat signal (77-78)
- ❷ Power supply 400V AC
- ❹ Alarm clean contact (99-99)

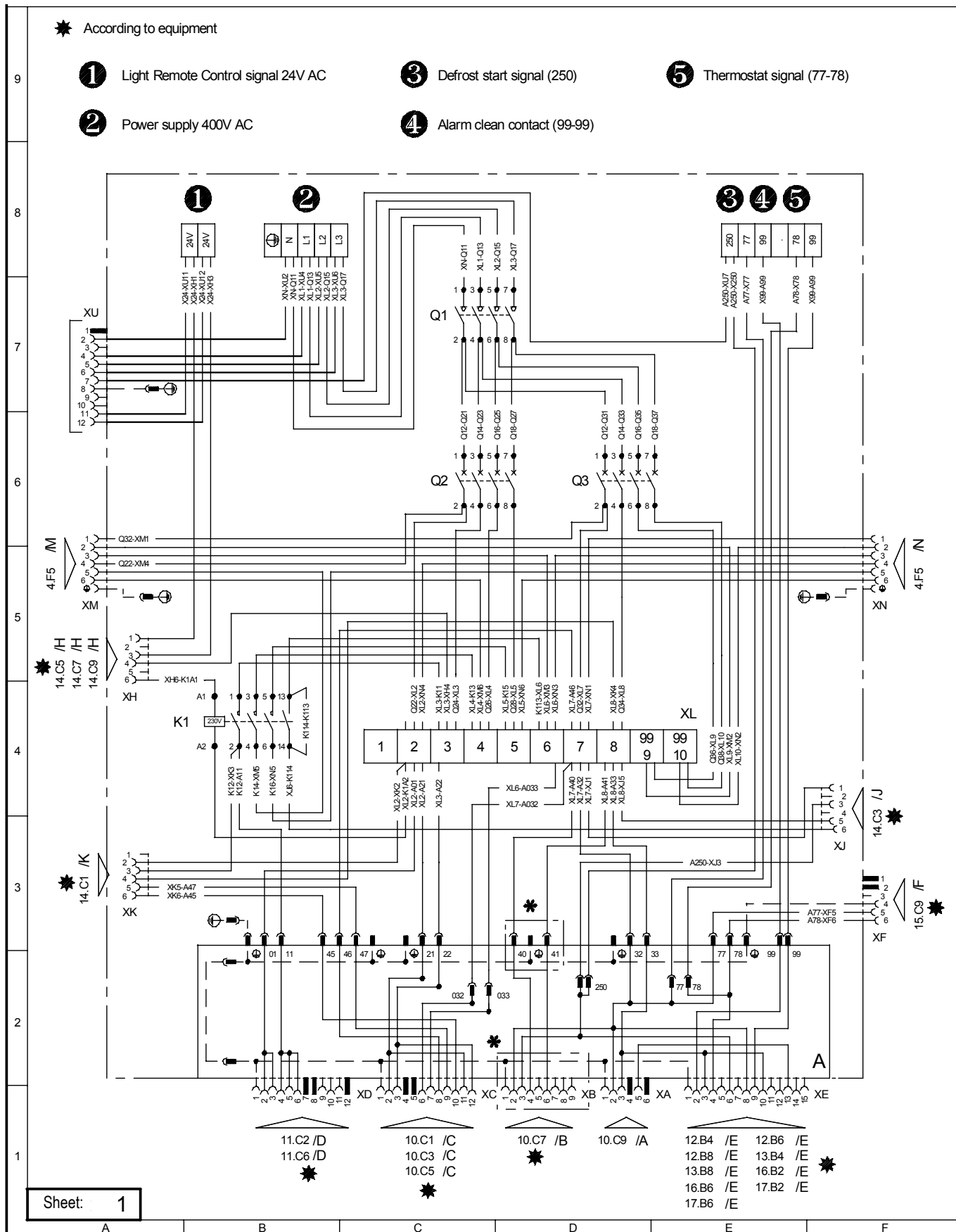

- 12.B4 /E 12.B6 /E
- 12.B8 /E 13.B4 /E
- 13.B8 /E 16.B2 /E
- 16.B6 /E 17.B2 /E
- 17.B6 /E

ORD.	DATE	ORD.	DATE
A		D	
B		E	
C		F	

WIRING DIAGRAM SRTS 2 (230V)
(Safety run terminal-strip for 2 cabinets)

★ According to equipment

- 1** Light Remote Control signal 24V AC
- 3** Defrost start signal (250)
- 5** Thermostat signal (77-78)
- 2** Power supply 230V AC
- 4** Alarm clean contact (99-99)

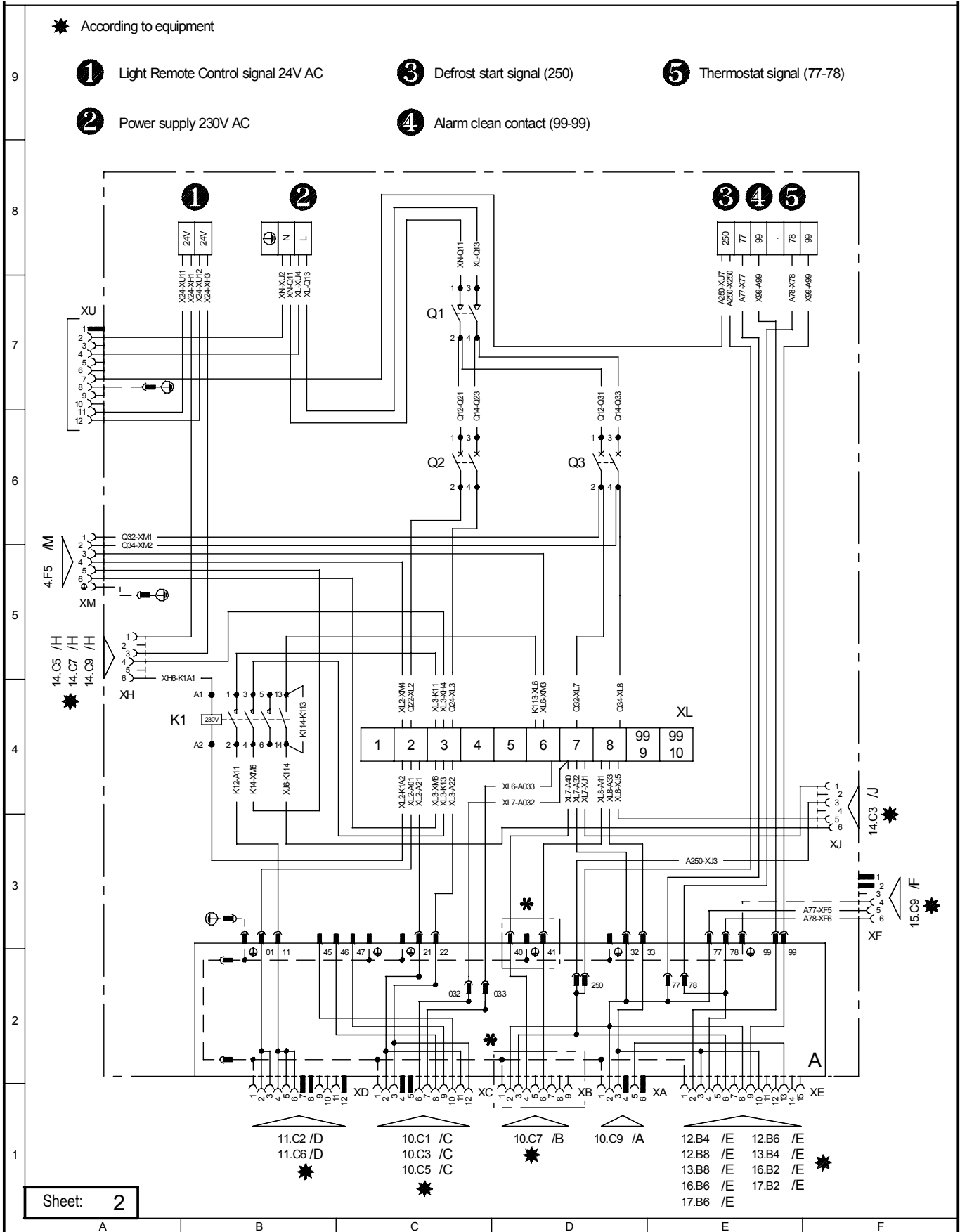

ORD.	DATE	ORD.	DATE
A		D	
B		E	
C		F	

WIRING DIAGRAM SRTS 1 (230V)
(Safety run terminal-strip for 1 cabinet)

★ According to equipment

- ❶ Light Remote Control signal 24V AC
- ❸ Defrost start signal (250)
- ❺ Thermostat signal (77-78)
- ❷ Power supply 230V AC
- ❹ Alarm clean contact (99-99)

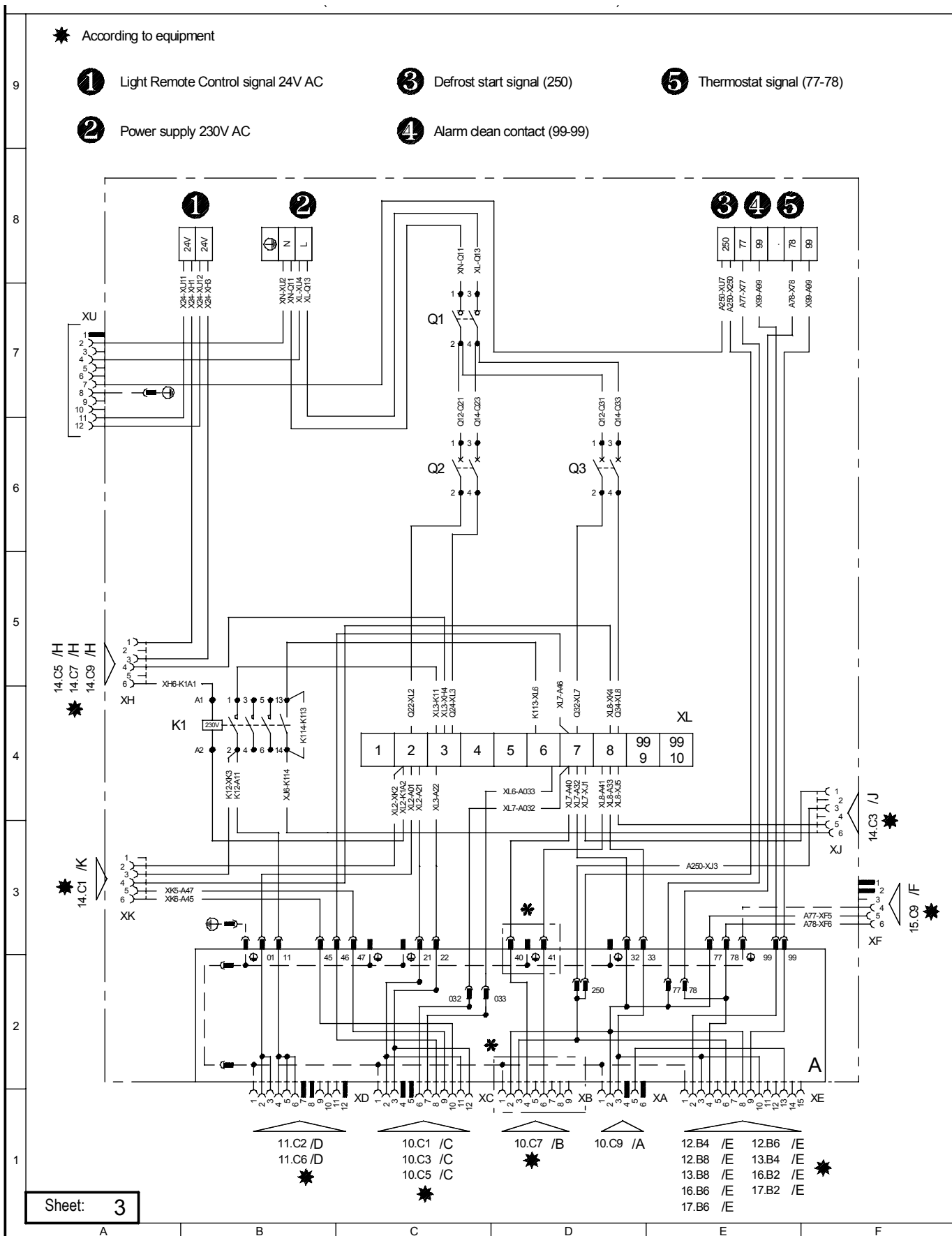

ORD.	DATE	ORD.	DATE
A		D	
B		E	
C		F	

WIRING DIAGRAM FTB
(Final terminal-strip)

* According to equipment

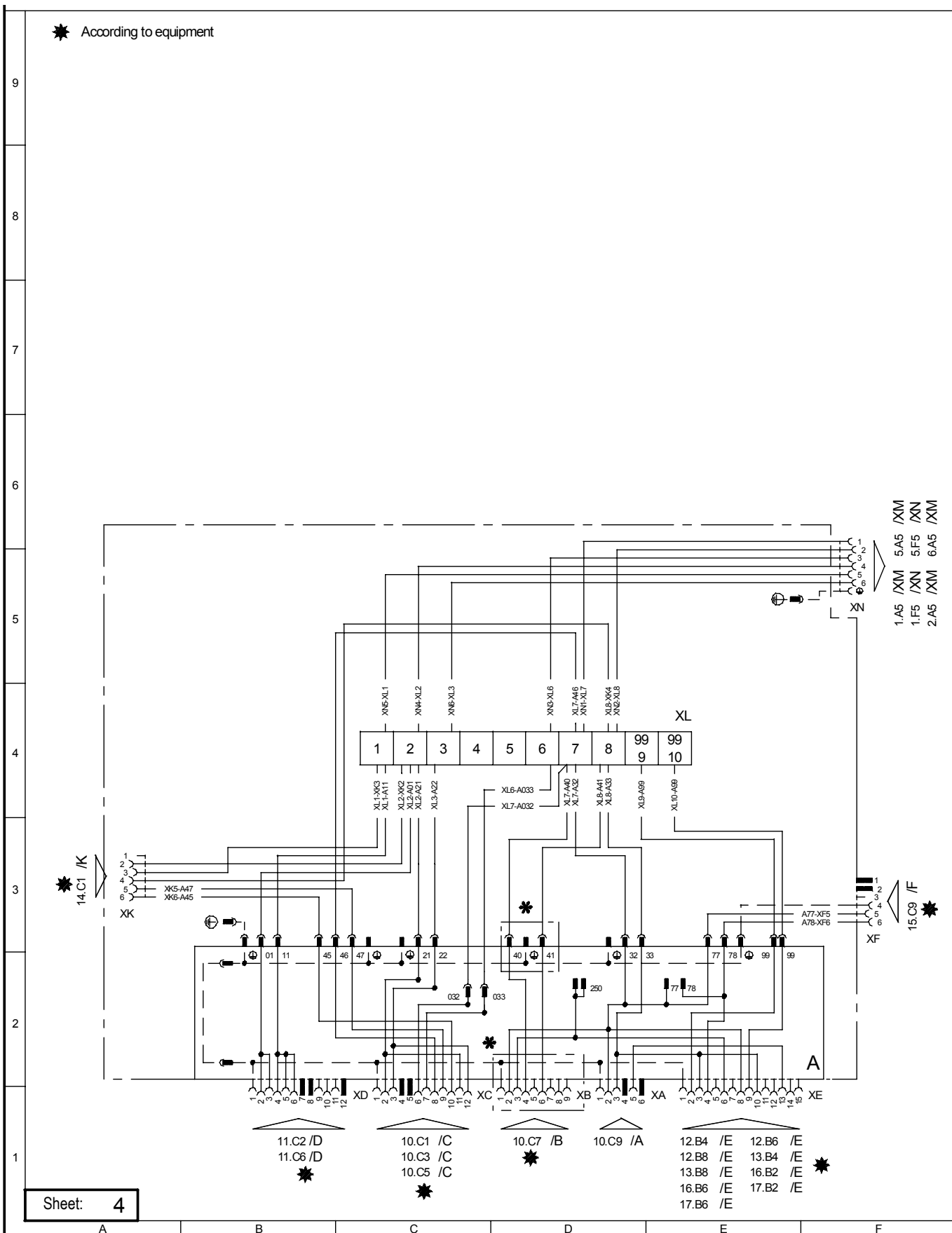

ORD.	DATE	ORD.	DATE
A		D	
B		E	
C		F	

WIRING DIAGRAM RTS 3 (400V)
(Run terminal-strip for 3 cabinets)

★ According to equipment

- 1** Light Remote Control signal 24V AC
- 3** Defrost start signal (250)
- 5** Thermostat signal (77-78)
- 2** Power supply 400V AC
- 4** Alarm clean contact (99-99)

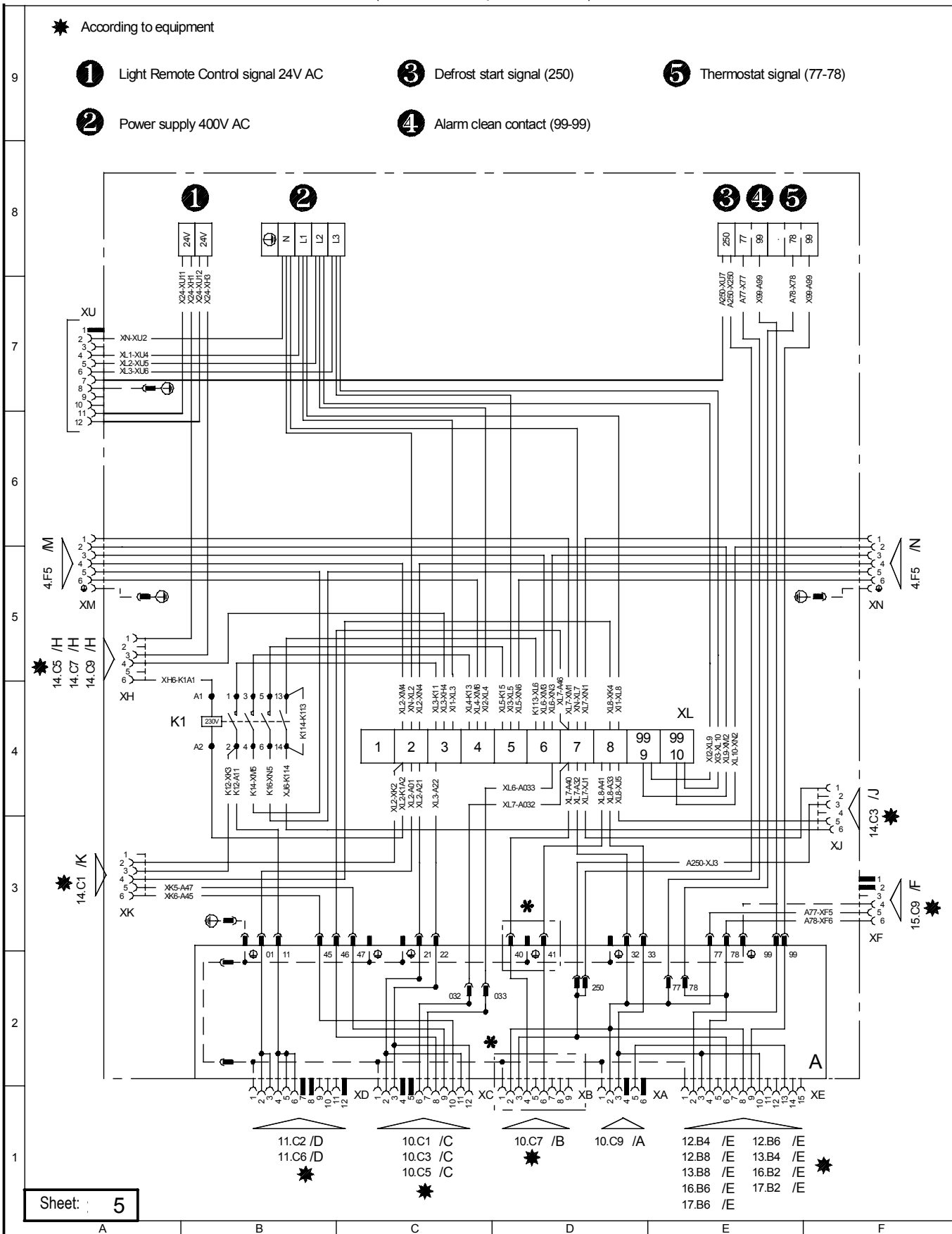

ORD.	DATE	ORD.	DATE
A		D	
B		E	
C		F	

WIRING DIAGRAM RTS 2 (230V) (Run terminal-strip for 2 cabinets)

★ According to equipment

- 1** Light Remote Control signal 24V AC
- 3** Defrost start signal (250)
- 5** Thermostat signal (77-78)
- 2** Power supply 230V AC
- 4** Alarm clean contact (99-99)

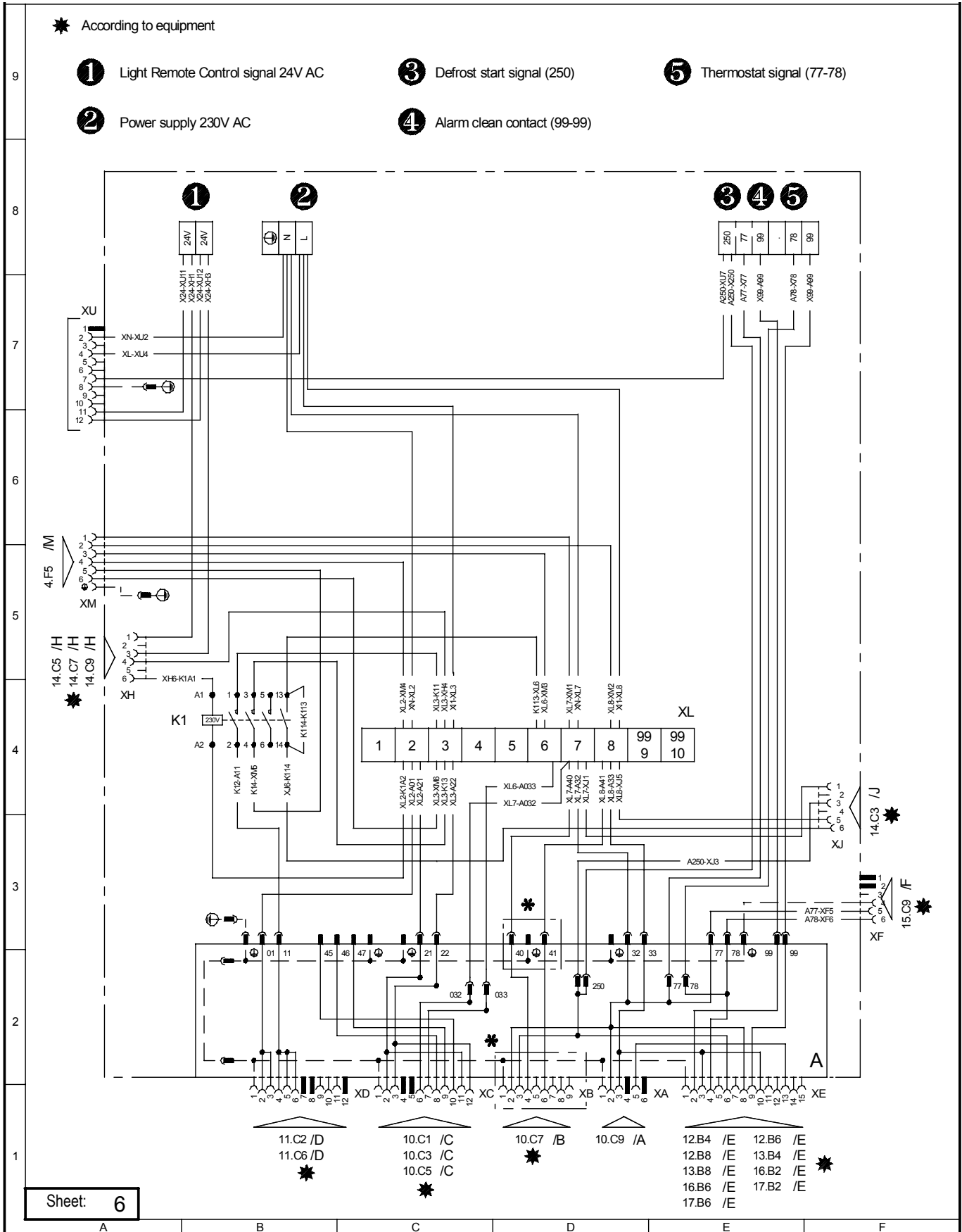

WIRING DIAGRAM RTS 1 (230V)
(Run terminal-strip for 1 cabinet)

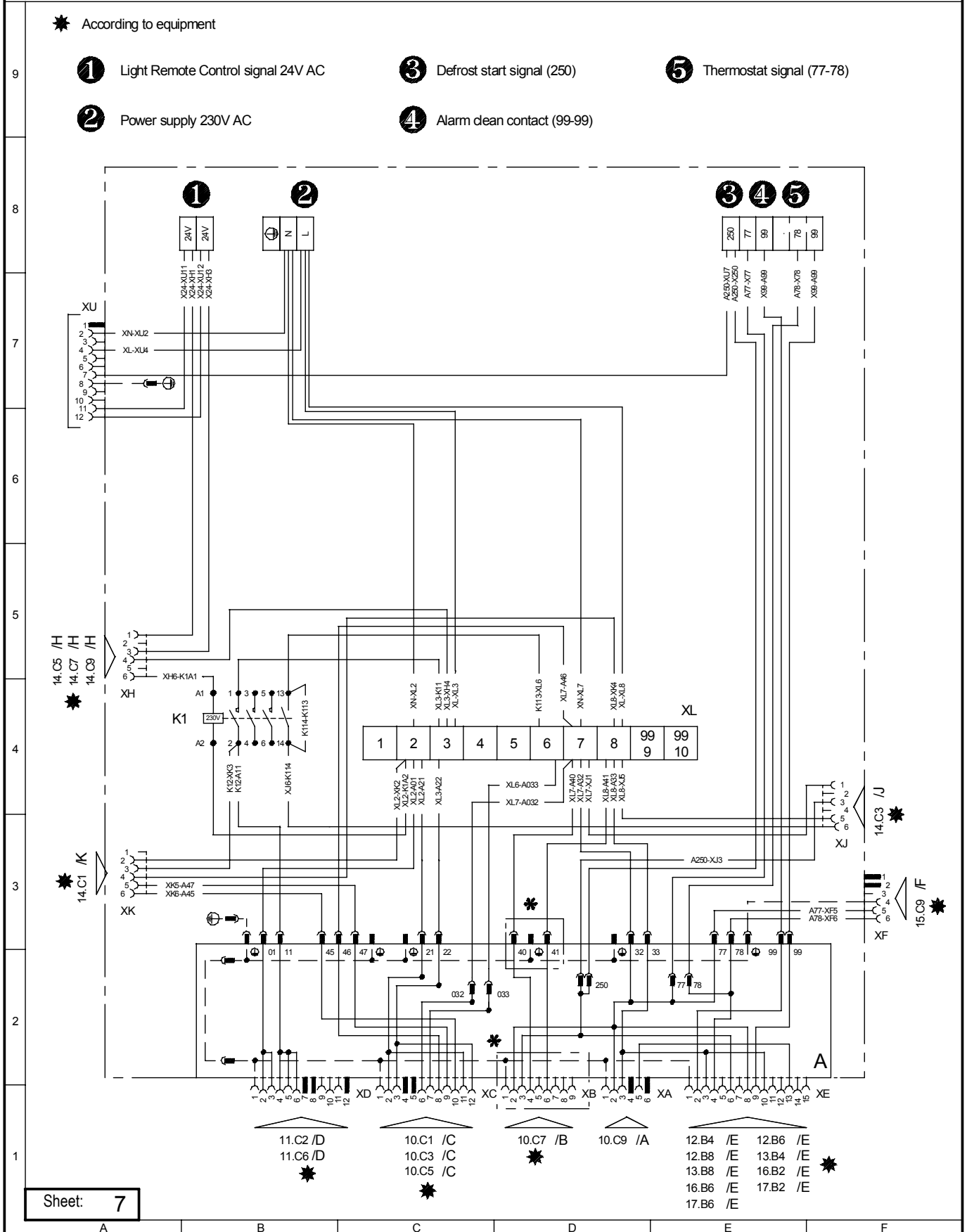

ORD.	DATE	ORD.	DATE
A		D	
B		E	
C		F	

WIRING DIAGRAM SRTS 3 (2x230V)

(Safety run terminal-strip for 3 cabinets)

✱ According to equipment

❶ Light power supply 230V AC

❸ Defrost start signal (250)

❺ Thermostat signal (77-78)

❷ Power supply 230V AC

❹ Alarm clean contact (99-99)

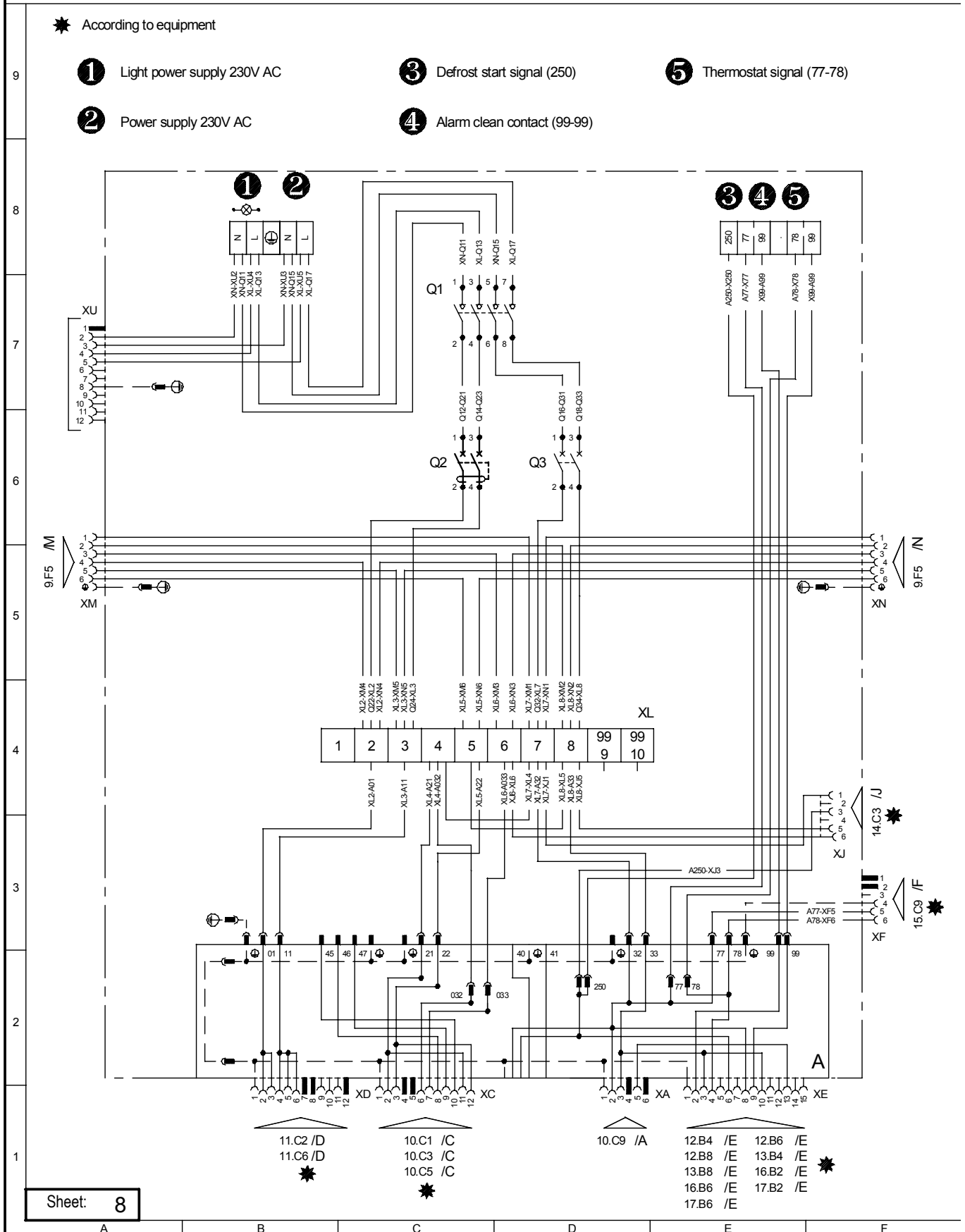

ORD.	DATE	ORD.	DATE
A		D	
B		E	
C		F	

IN CONFORMITY WITH APPROVED ORIGINAL

DATE OF 1st ISSUE:
10.May.04

WIRING DIAGRAM ITB
(Final terminal-board)

★ According to equipment

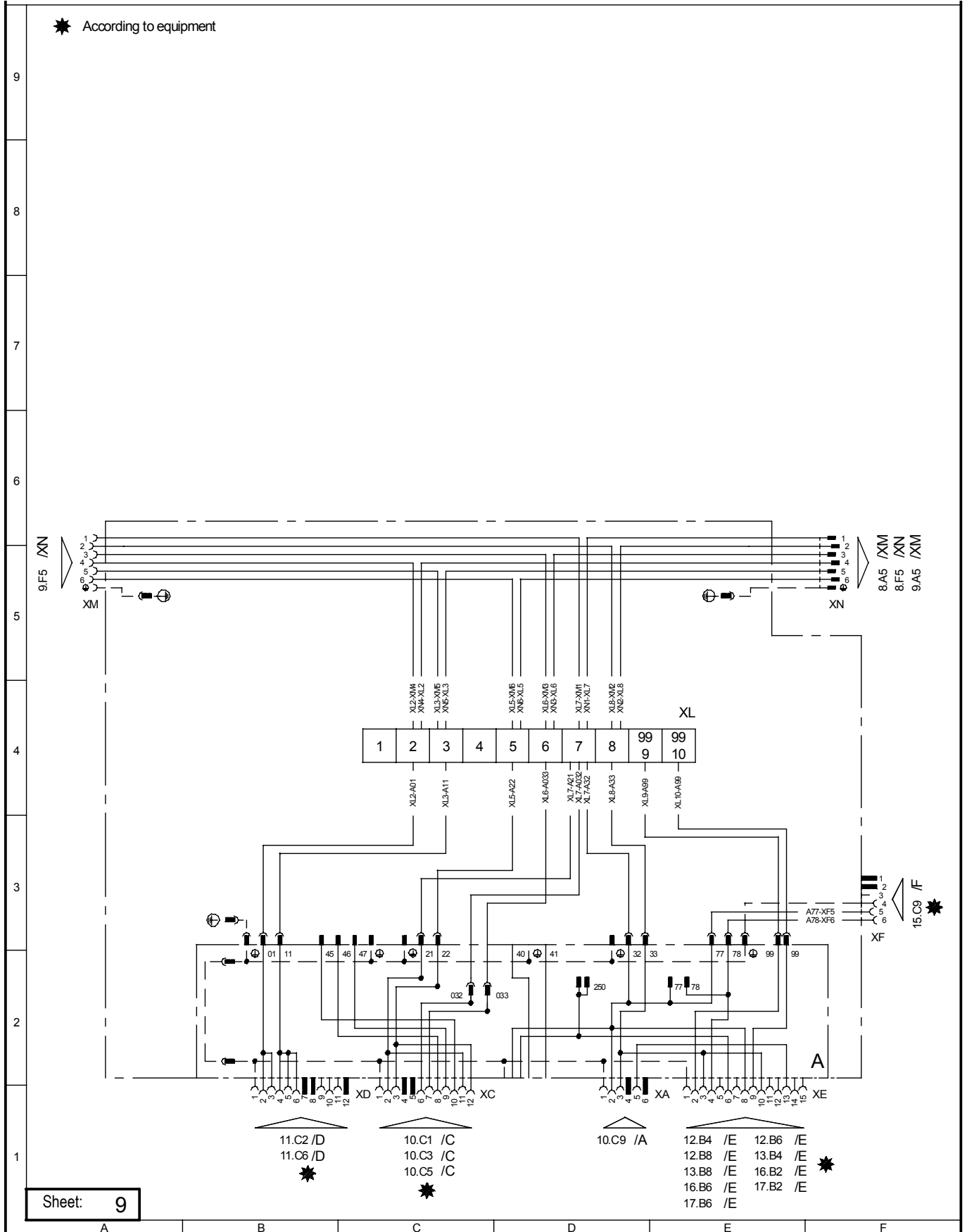

ORD.	DATE	ORD.	DATE
A		D	
B		E	
C		F	

**WIRING DIAGRAM
(FANS/DEFROST/HEATERS)**

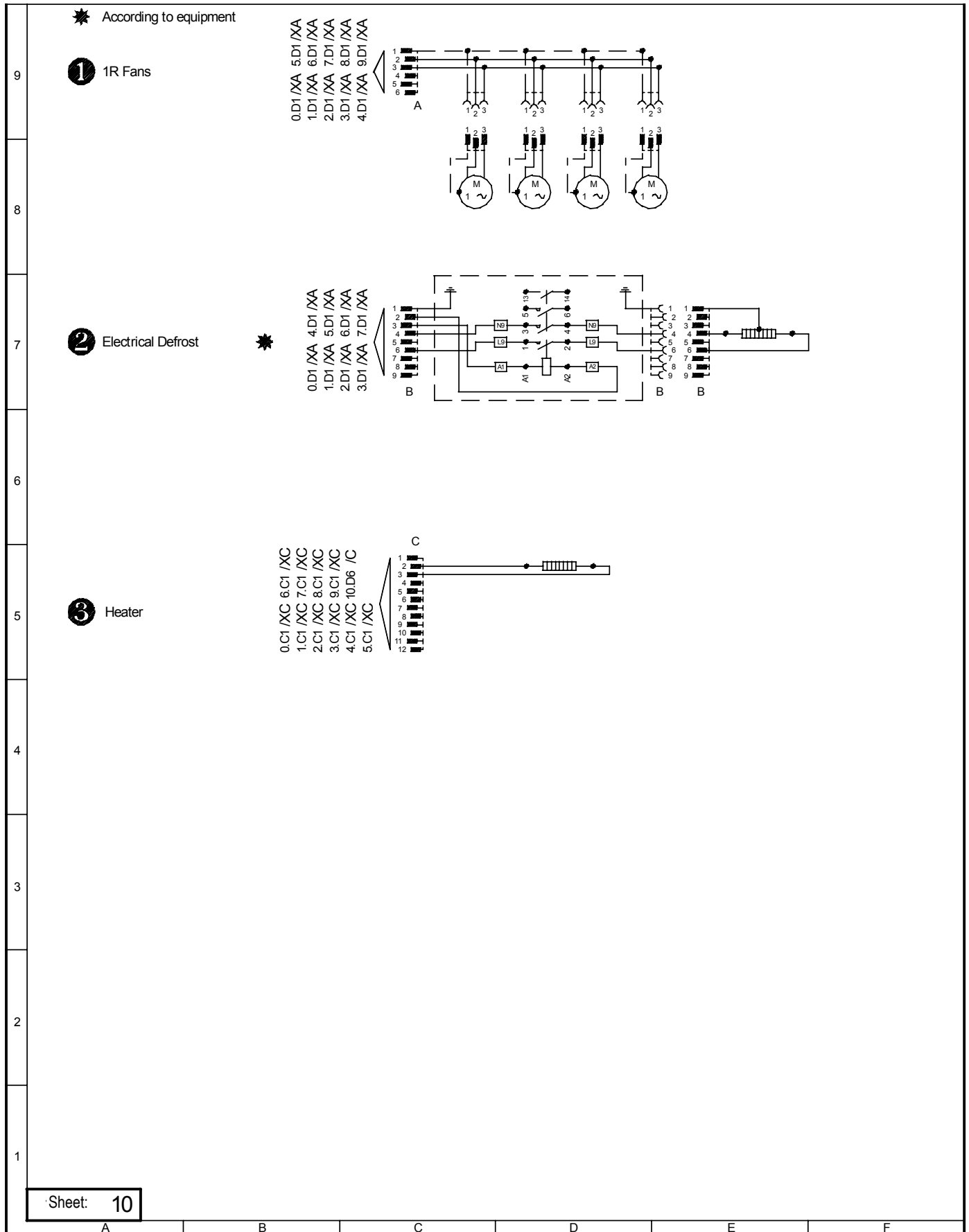

ORD.	DATE	ORD.	DATE
A		D	
B		E	
C		F	

IN CONFORMITY WITH APPROVED ORIGINAL
DATE OF 1st ISSUE: **10.May.04**

WIRING DIAGRAM (LIGHTING)

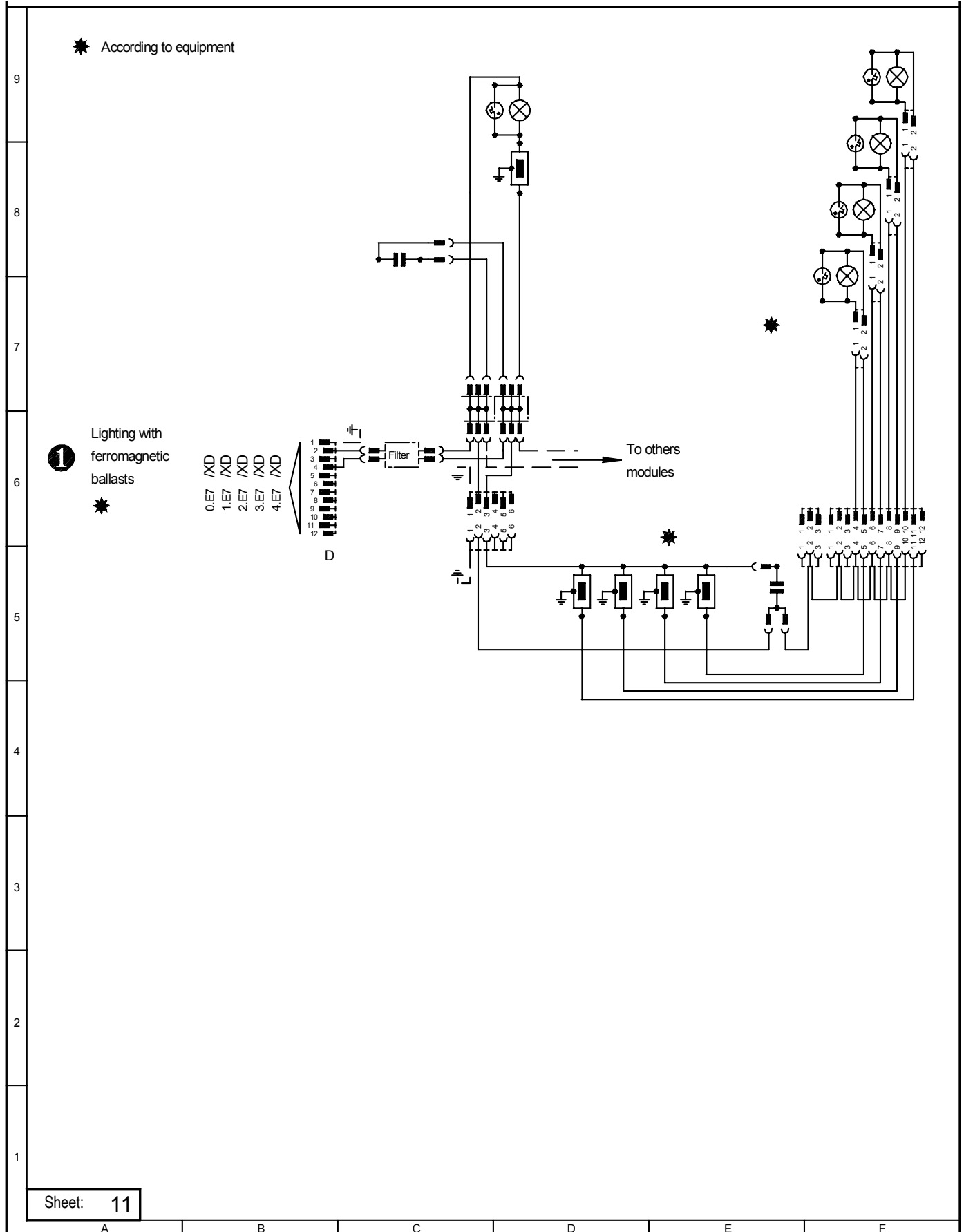

ORD.	DATE	ORD.	DATE
A		D	
B		E	
C		F	

CHAP. N° **9**
IN CONFORMITY WITH APPROVED ORIGINAL

DATE OF 1st ISSUE: **10.May.04**

WIRING DIAGRAM (DISPLAY/THERMOSTAT)

★ According to equipment

1 EKC101 ★

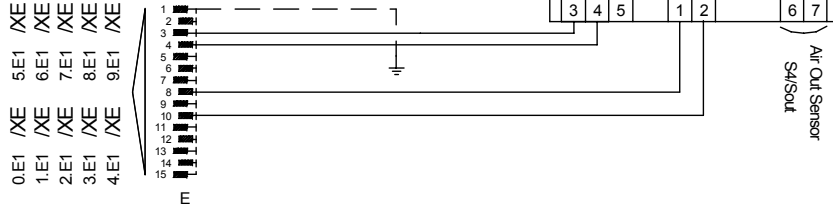

2 EKA151 ★

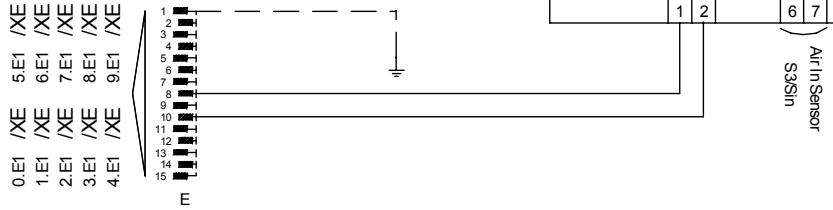

3 PLUG ★

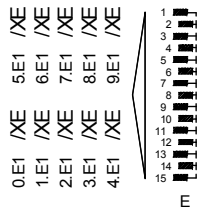

WIRING DIAGRAM (EKC201)

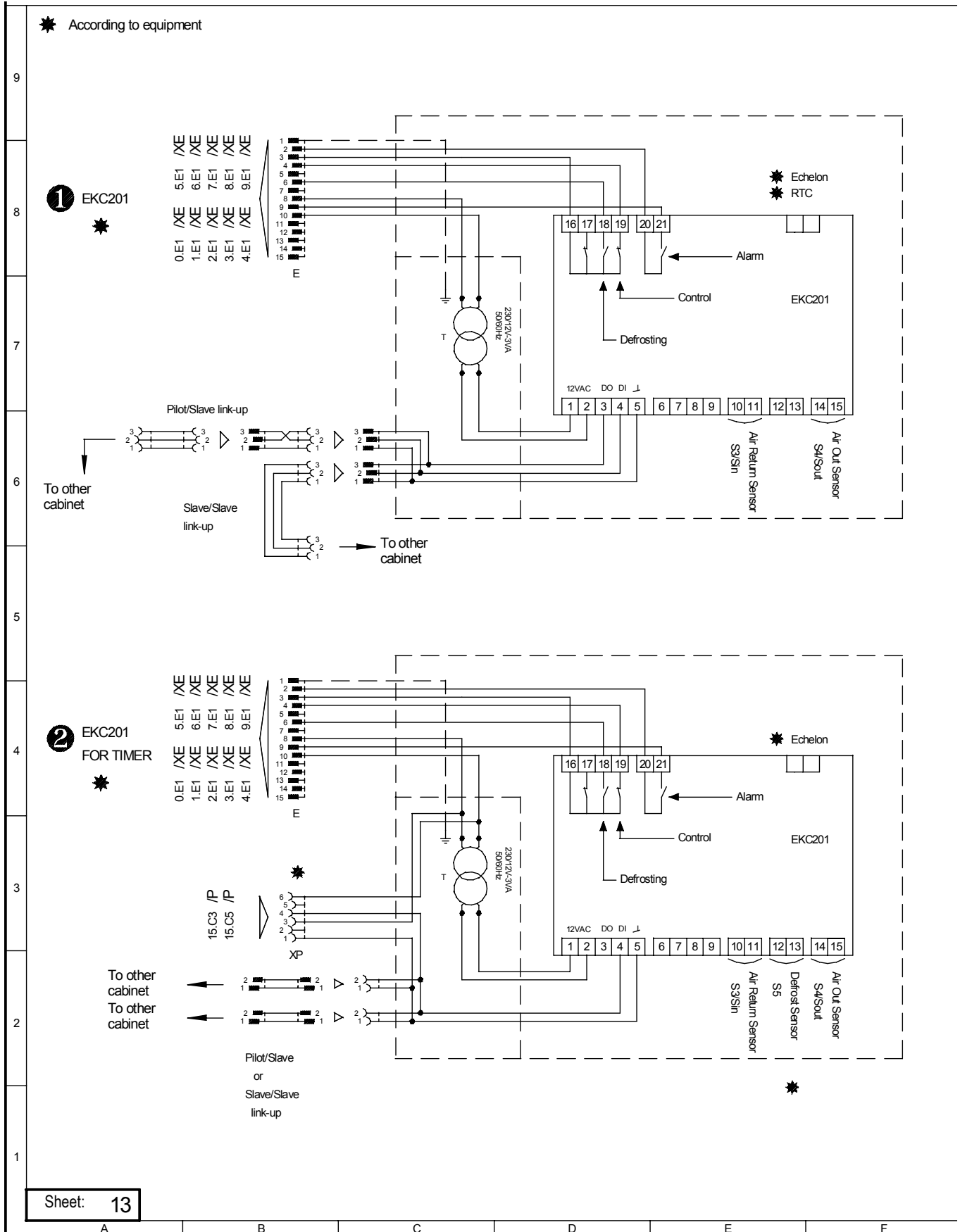

ORD.	DATE	ORD.	DATE
A		D	
B		E	
C		F	

WIRING DIAGRAMS (Options RTS-SRST-FTB)

★ According to equipment

1 Light remote control relay
(RTS/SRTS)

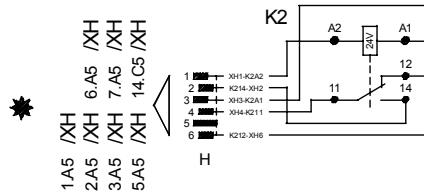

2 Light switch
(RTS/SRTS)

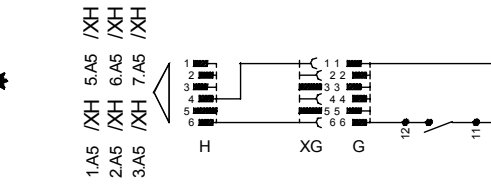

3 Light remote control relay
+ Light switch
(RTS/SRTS)

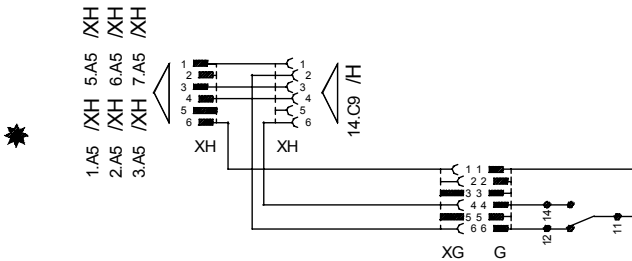

COSTAN TECHNICAL DOCUMENTATION	CHAPTER REVISION STATUS				DOC. N°	PAGE: 18/19
	ORD.	DATE	ORD.	DATE	QSM000165E	
PRODUCT: AERIA N/L 15 CHAPTER: WIRING DIAGRAMS	A		D		CHAP. N° 9	DATE OF 1st ISSUE: 10.May.04
	B		E		IN CONFORMITY WITH APPROVED ORIGINAL	
	C		F			

WIRING DIAGRAM (AC-DC SOLENOID VALVE/DEFROST RELAY/TIMER)

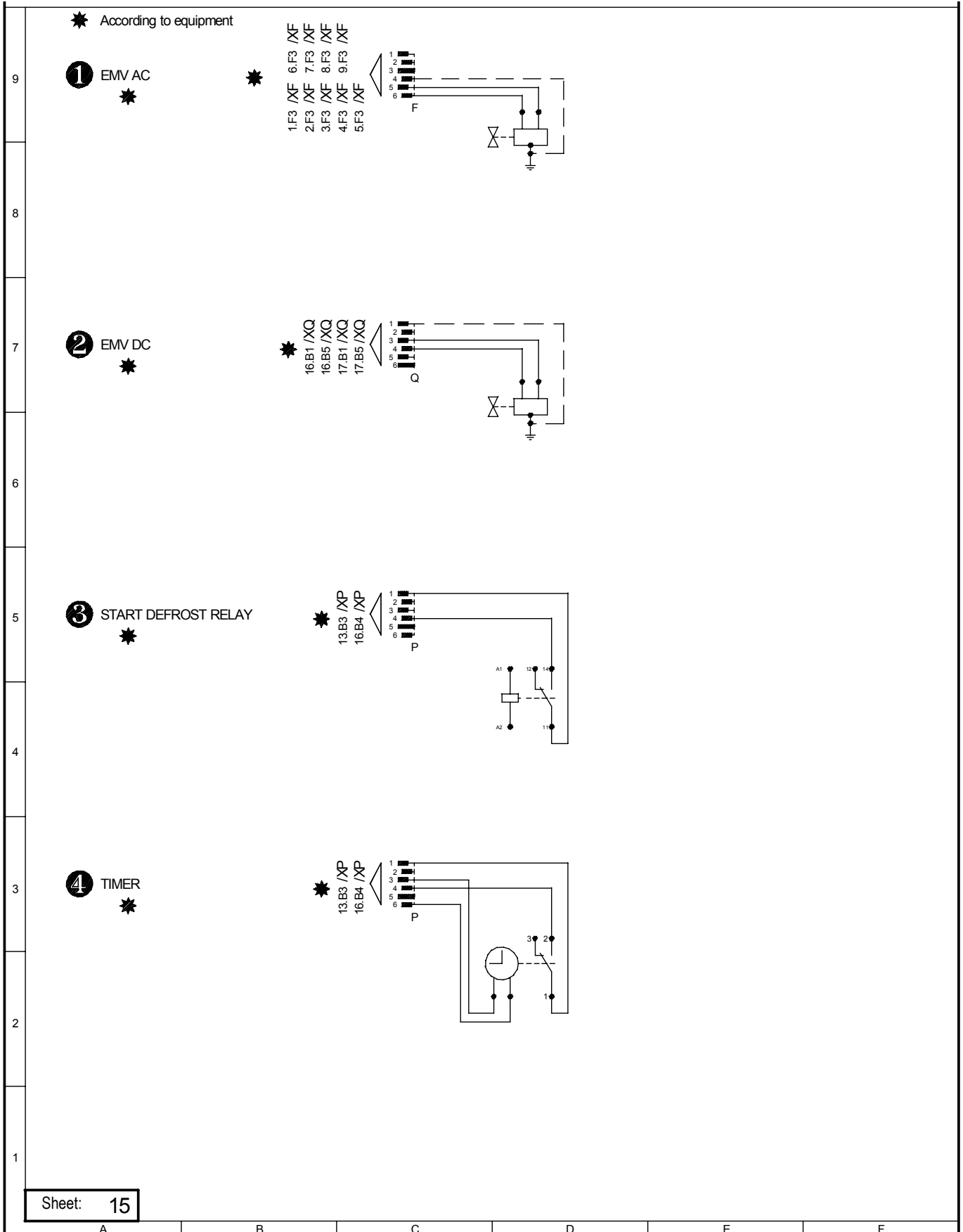

ORD.	DATE	ORD.	DATE
A		D	
B		E	
C		F	

WIRING DIAGRAM (EKC414A)

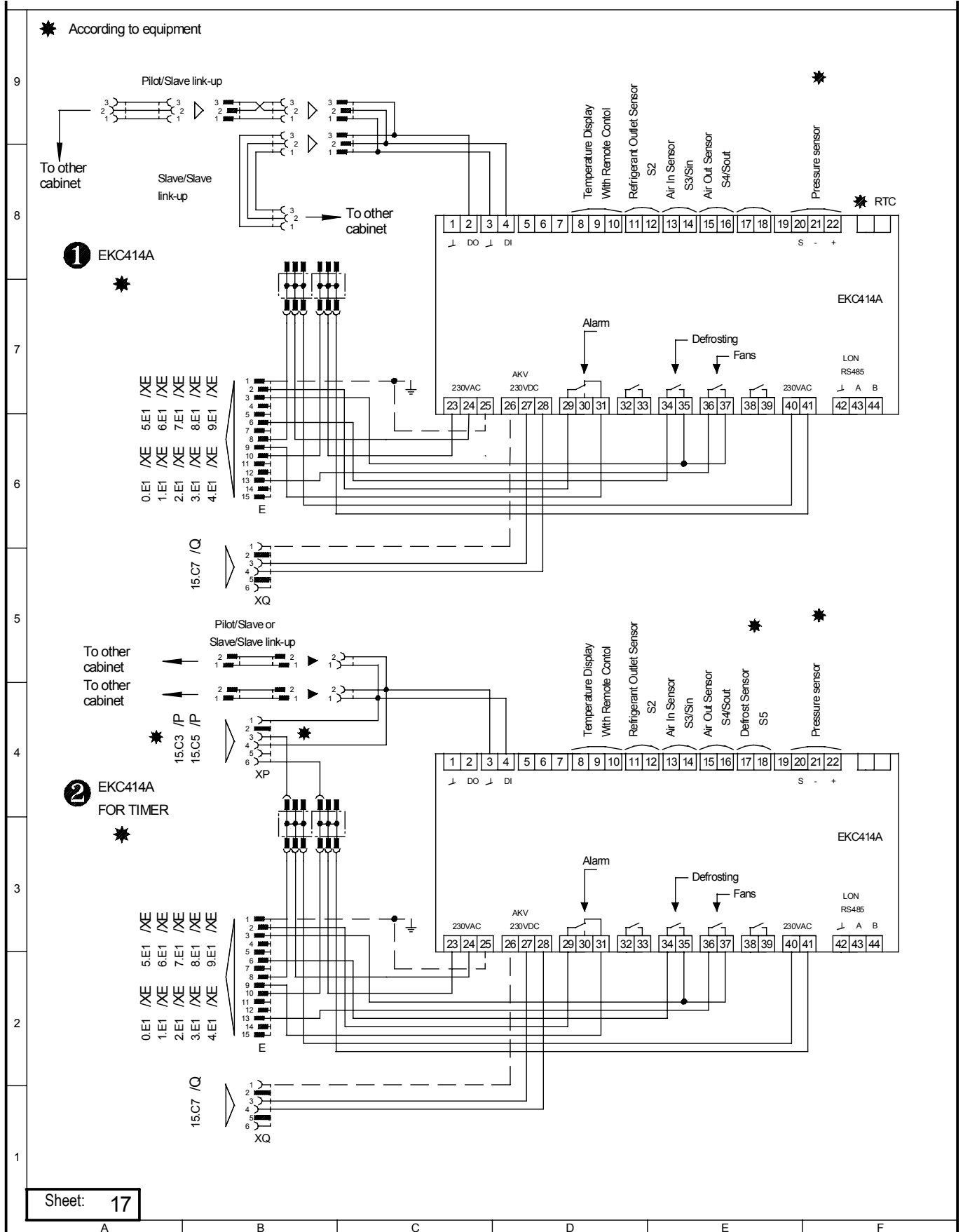

COSTAN TECHNICAL DOCUMENTATION	CHAPTER REVISION STATUS				DOC. N° QSM000165E	PAGE: 1/9
	ORD.	DATE	ORD.	DATE		
PRODUCT: AERIA N/L 15 CHAPTER: MULTIPLEXING CABINETS	A		D		IN CONFORMITY WITH APPROVED ORIGINAL	DATE OF 1st ISSUE: 10.May.04
	B		E			
	C		F			

MULTIPLEXING CABINETS

UNPACK THE CABINETS

Unpack the cabinets, remove wood skids as shown in the pictures.



POSITION THE CABINETS

Bring the cabinets to their service position. Check that the cabinets are level using a spirit level (1-2). Remove bottom plates using a screwdriver (3). Level the cabinets using a ratchet wrench on the side feet. (4).

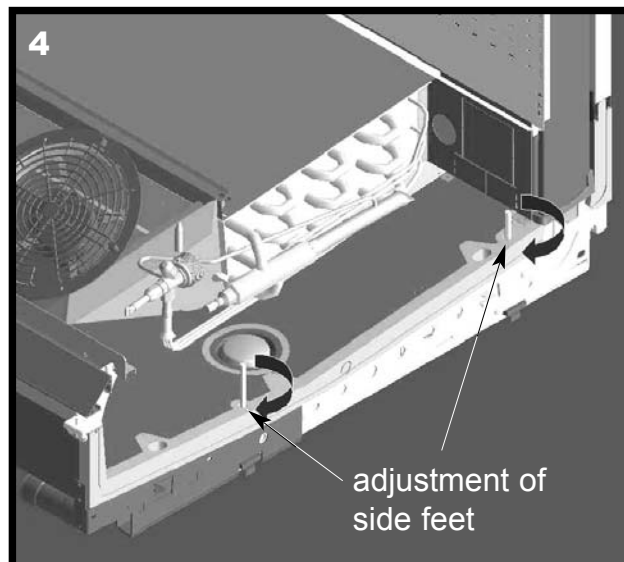

COSTAN TECHNICAL DOCUMENTATION	CHAPTER REVISION STATUS				DOC. N°	PAGE: 2/9
	ORD.	DATE	ORD.	DATE	QSM000165E	
PRODUCT: AERIA N/L 15 CHAPTER: MULTIPLEXING CABINETS	A		D		N° CAP. 10	IN CONFORMITY WITH APPROVED ORIGINAL DATE OF 1st ISSUE: 10.May.04
	B		E			
	C		F			

APPLY SPONGE RUBBER

Apply sponge rubber onto the side of one of the cabinets to be multiplexed following the instructions in the figure.

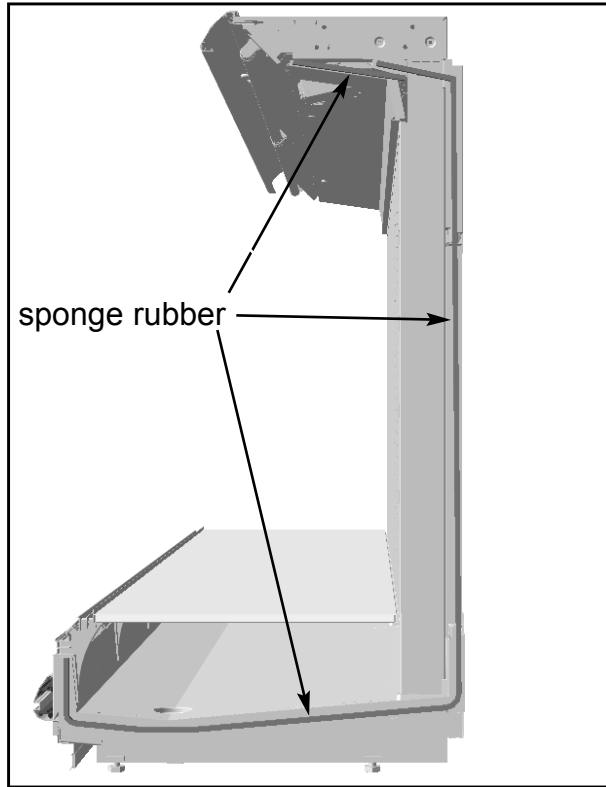

PLACE ALIGNMENT PINS

Put two alignment pins in the canopy and two in the ticket holder of one of the cabinets to be multiplexed as shown in the figure.

Then place the steel bumper rail plastic alignment joints.

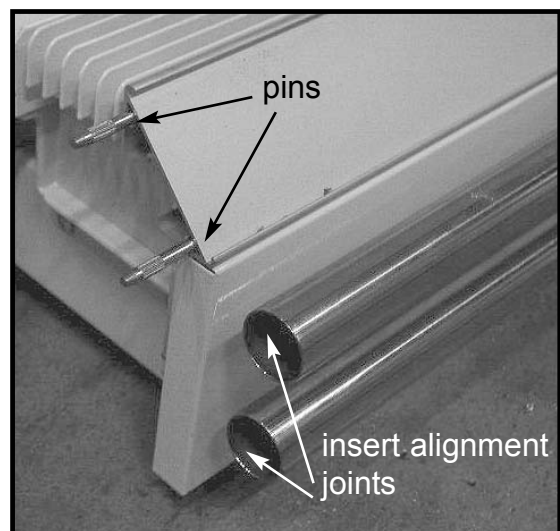
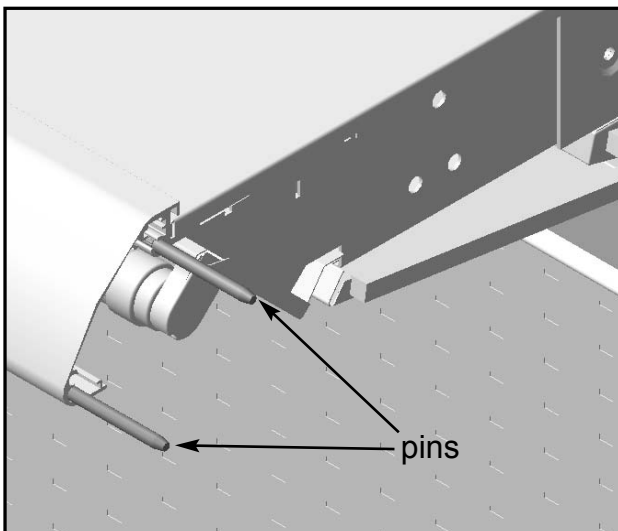

COSTAN TECHNICAL DOCUMENTATION	CHAPTER REVISION STATUS				DOC. N°	PAGE: 3/9
	ORD.	DATE	ORD.	DATE	QSM000165E	
PRODUCT: AERIA N/L 15	A		D		N° CHAP. 10	DATE OF 1st ISSUE: 10.May.04
CHAPTER: MULTIPLEXING CABINETS	B		E		IN CONFORMITY WITH APPROVED ORIGINAL	
	C		F			

MULTIPLEXING CABINETS: JOINING BACKS DOWN AT THE BOTTOM LINEAR CABINET / LINEAR CABINET

Once the alignment pins have been fitted in, proceed as follows.

- 1) Insert sheet-metal joints into the lower rear part of the cabinet, as shown in the drawing.
- 2) Bolt the cabinets to one another with a hex-head screw M8x90.

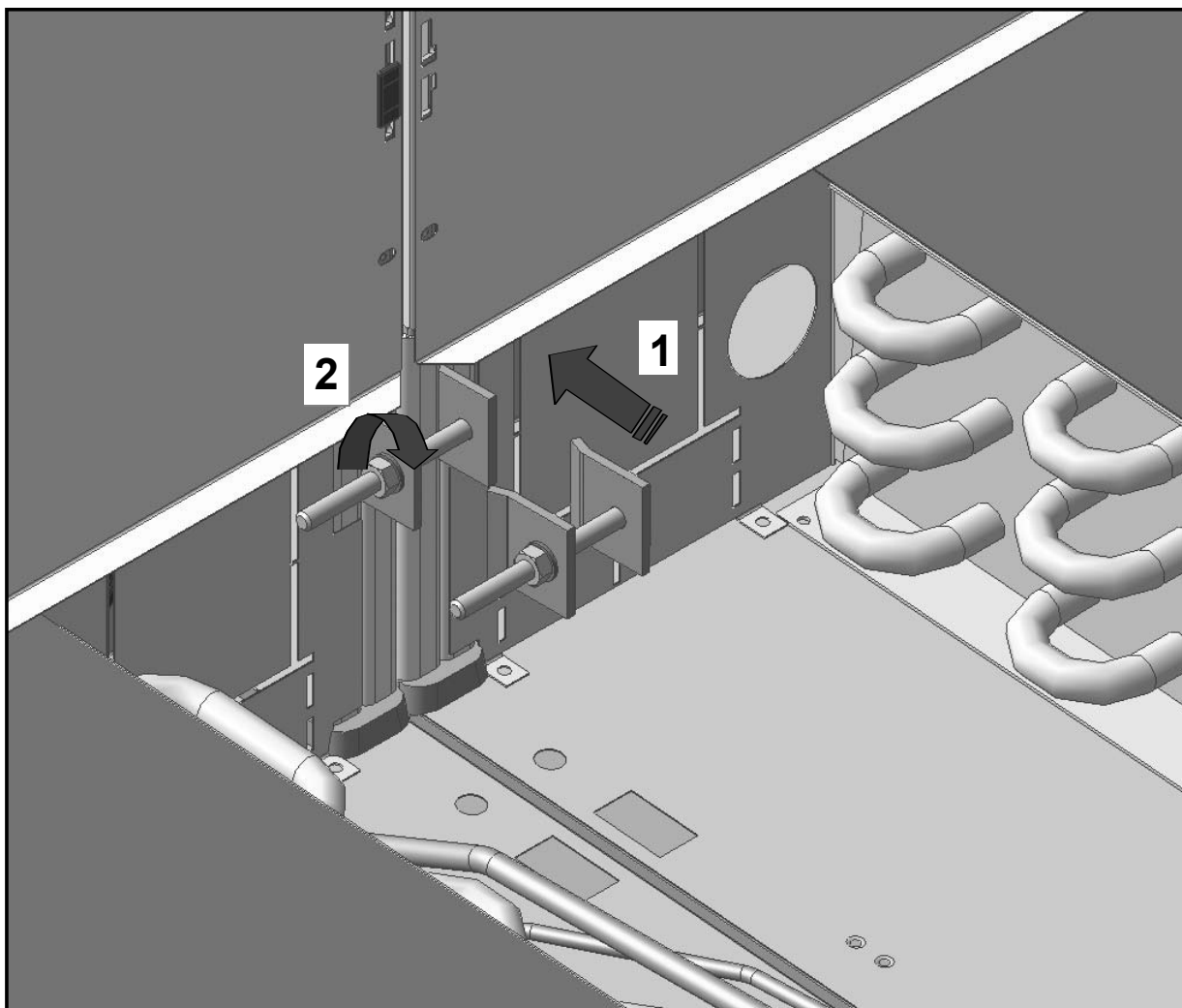

COSTAN TECHNICAL DOCUMENTATION	CHAPTER REVISION STATUS				DOC. N°	PAGE: 4/9
	ORD.	DATE	ORD.	DATE	QSM000165E	
PRODUCT: AERIA N/L 15 CHAPTER: MULTIPLEXING CABINETS	A		D		N° CAP. 10	DATE OF 1st ISSUE: 10.May.04
	B		E		IN CONFORMITY WITH APPROVED ORIGINAL	
	C		F			

MULTIPLEXING CABINETS: JOINING CHEST FRONTS LINEAR CABINET / LINEAR CABINET

Join the cabinets at the front of the chests using a hex-head screw M8x90 and the relevant nut as shown in the drawing.

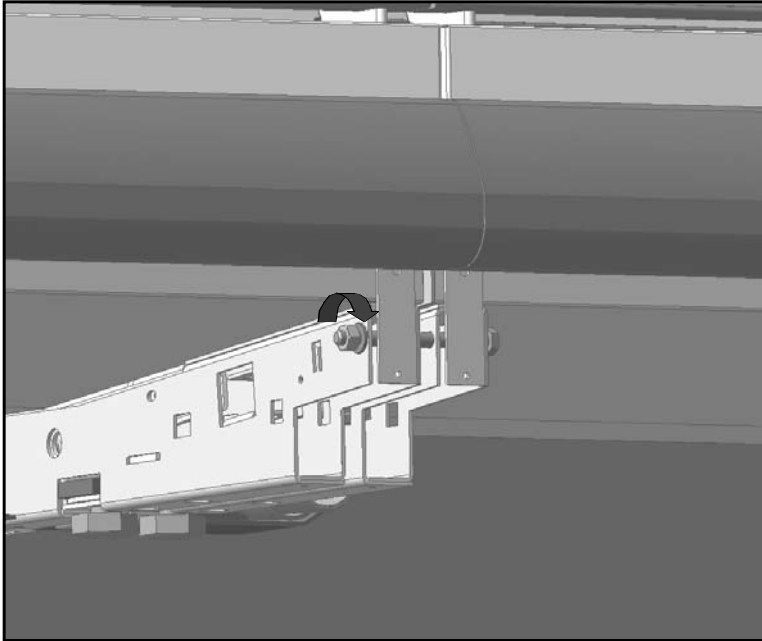

MULTIPLEXING CABINETS: JOINING THE UPPER PART LINEAR CABINET / LINEAR CABINET

Remove the sheet-metal top cover; bolt the cabinets to one another in the two upper points marked in the drawing using hex-head screws M8x90 and the relevant nuts.

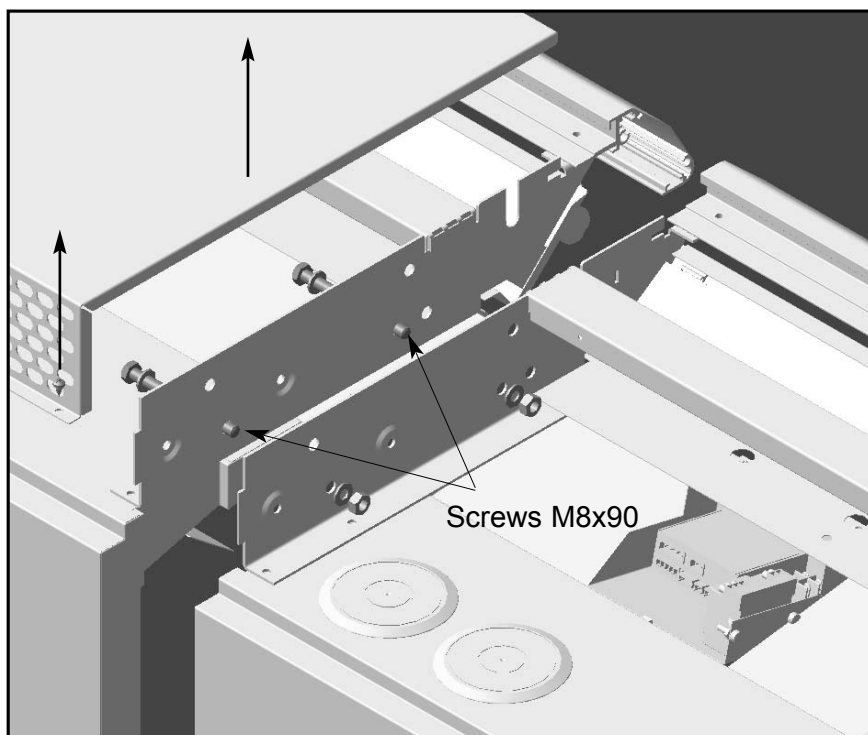

COSTAN TECHNICAL DOCUMENTATION	CHAPTER REVISION STATUS				DOC. N° QSM000165E N° CAP. 10	PAGE: 5/9
	ORD.	DATE	ORD.	DATE		
PRODUCT: AERIA N/L 15 CHAPTER: MULTIPLEXING CABINETS	A		D		IN CONFORMITY WITH APPROVED ORIGINAL	DATE OF 1st ISSUE: 10.May.04
	B		E			
	C		F			

MULTIPLEXING CABINETS: CHEST COUPLING LINEAR CABINET / HEAD CABINET

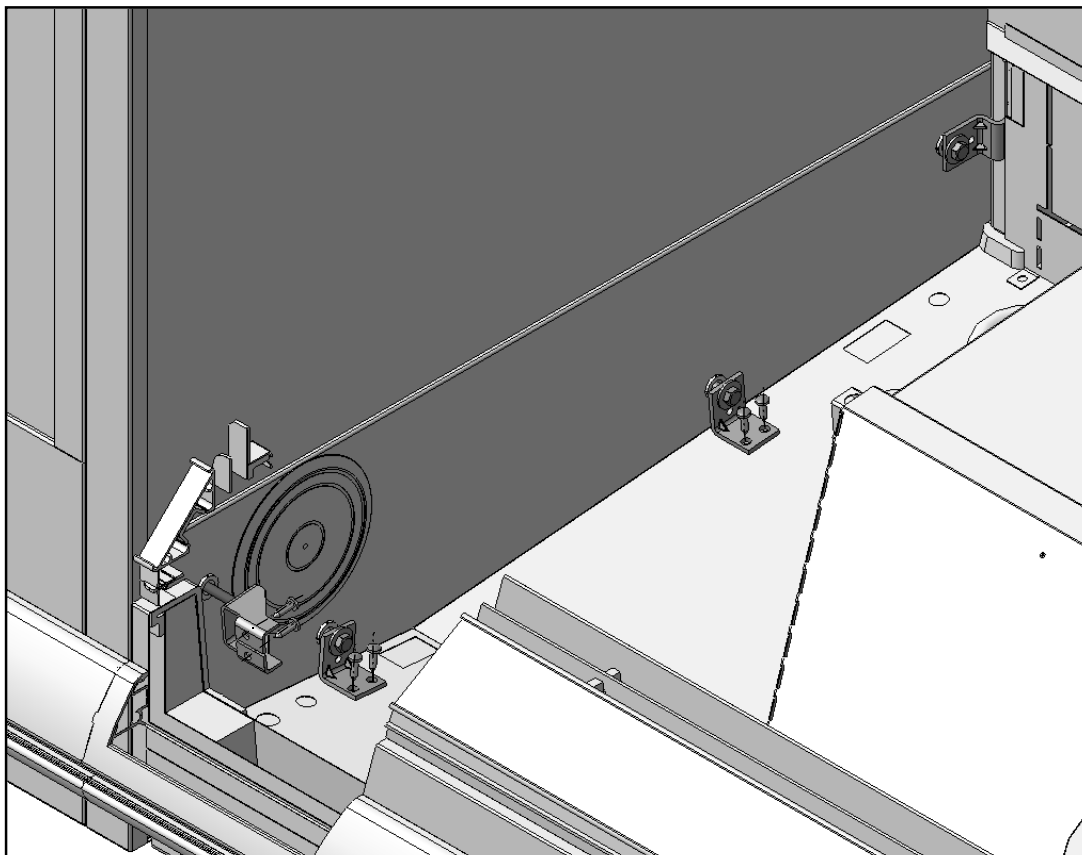
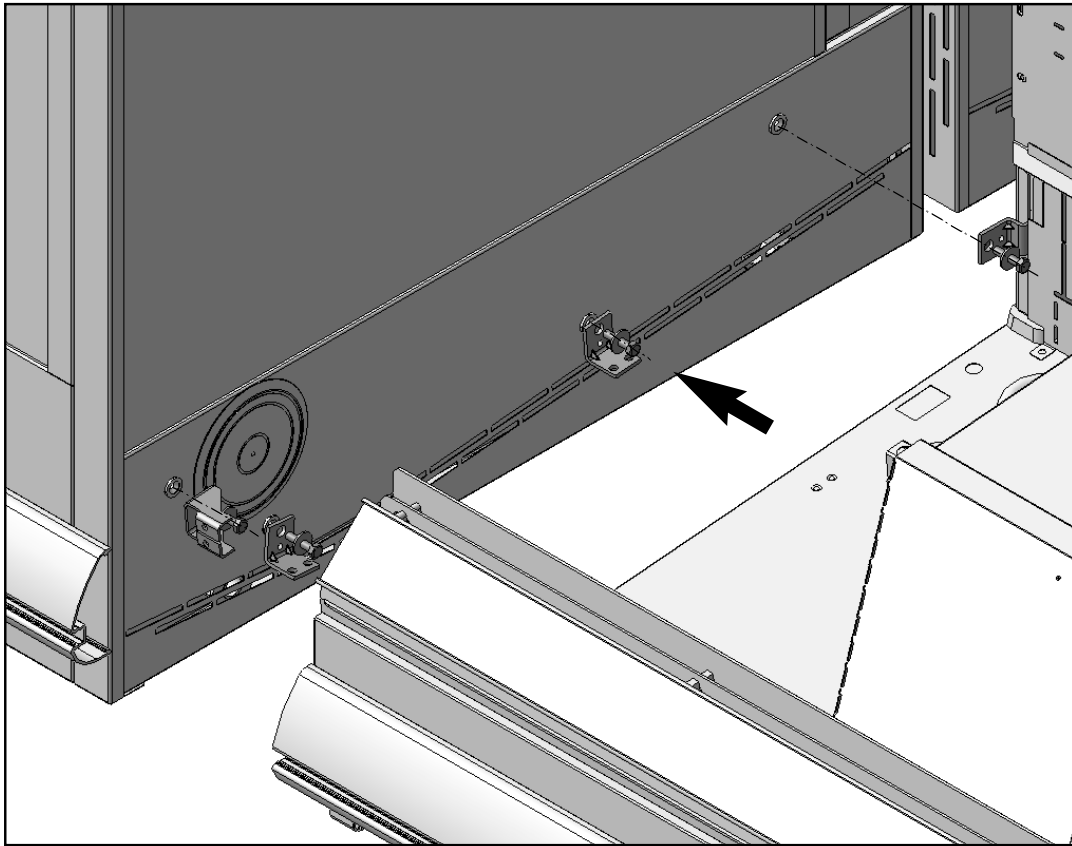

COSTAN TECHNICAL DOCUMENTATION	CHAPTER REVISION STATUS				DOC. N°	PAGE: 6/9
	ORD.	DATE	ORD.	DATE	QSM000165E	
PRODUCT: AERIA N/L 15 CHAPTER: MULTIPLEXING CABINETS	A		D		N° CAP. 10	DATE OF 1st ISSUE: 10.May.04
	B		E		IN CONFORMITY WITH APPROVED ORIGINAL	
	C		F			

MULTIPLEXING CABINETS: JOINING THE UPPER PART LINEAR CABINET / HEAD CABINET

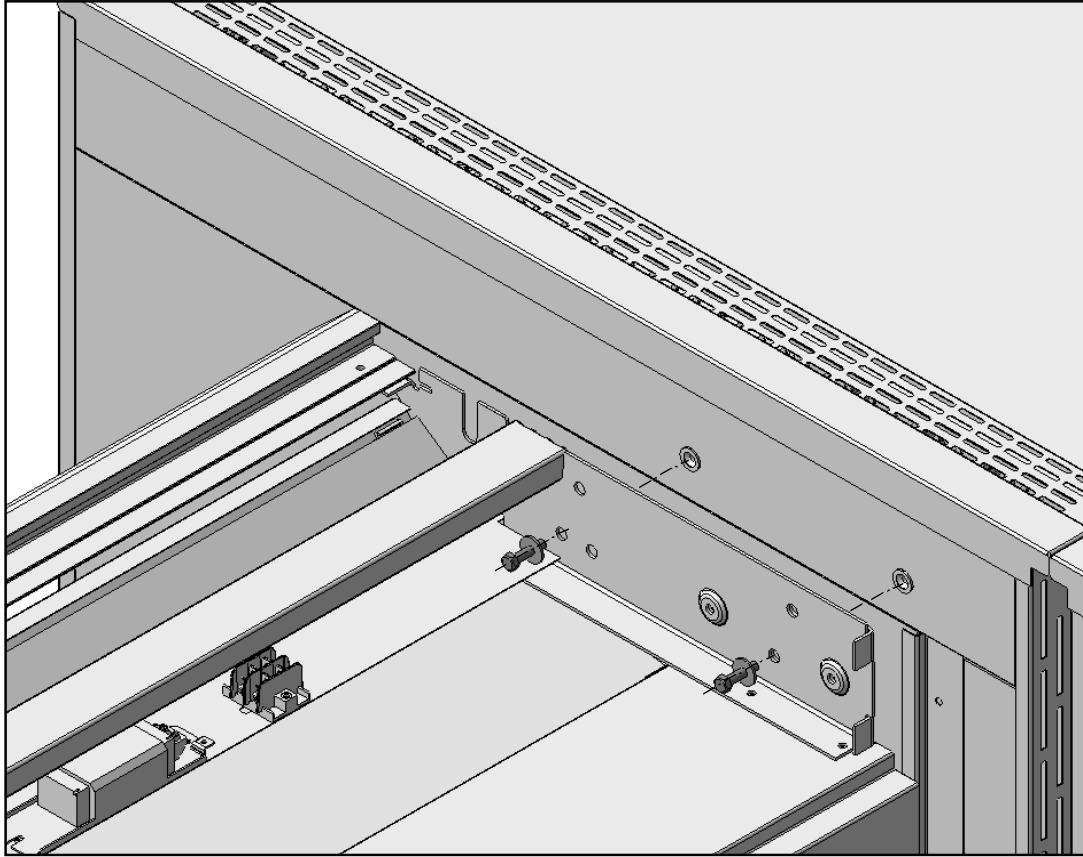

COSTAN TECHNICAL DOCUMENTATION	CHAPTER REVISION STATUS				DOC. N° QSM000165E	PAGE: 7/9
	ORD.	DATE	ORD.	DATE		
PRODUCT: AERIA N/L 15 CHAPTER: MULTIPLEXING CABINETS	A		D		IN CONFORMITY WITH APPROVED ORIGINAL	DATE OF 1st ISSUE: 10.May.04
	B		E			
	C		F			

CHECK LEVELNESS

Once the cabinets have been fastened, check that they are level and properly aligned using a spirit level (fig. 1 - 2).

If necessary, correct cabinet levelness adjusting the side feet from inside the cabinet (fig. 3) and then, pulling the appropriate strings, let middle feet down until they touch the ground (fig. 4).

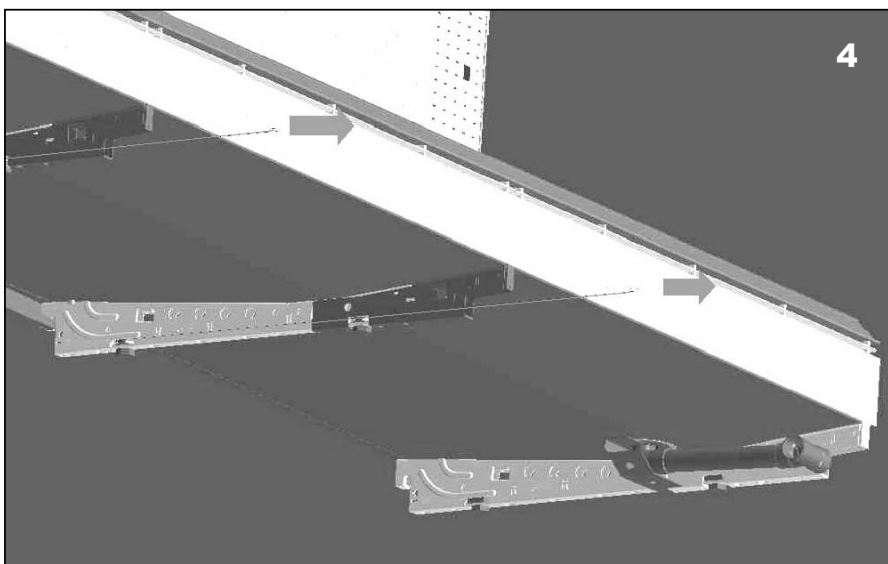

COSTAN TECHNICAL DOCUMENTATION	CHAPTER REVISION STATUS				DOC. N°	PAGE: 8/9
	ORD.	DATE	ORD.	DATE	QSM000165E	
PRODUCT: AERIA N/L 15 CHAPTER: MULTIPLEXING CABINETS	A		D		N° CAP. 10	DATE OF 1st ISSUE: 10.May.04
	B		E		IN CONFORMITY WITH APPROVED ORIGINAL	
	C		F			

COVERING THE JOINT BETWEEN CHESTS

Cover the joint between adjoining chests using aluminised tape as shown in the photo.



INSTALL PLINTHS

When the cabinet installation is complete with all its electrical, refrigerating and water connections, fit the front plinths using self-tapping screws (use a screwdriver or electric screwdriver with a cross-slotted P2 bit).

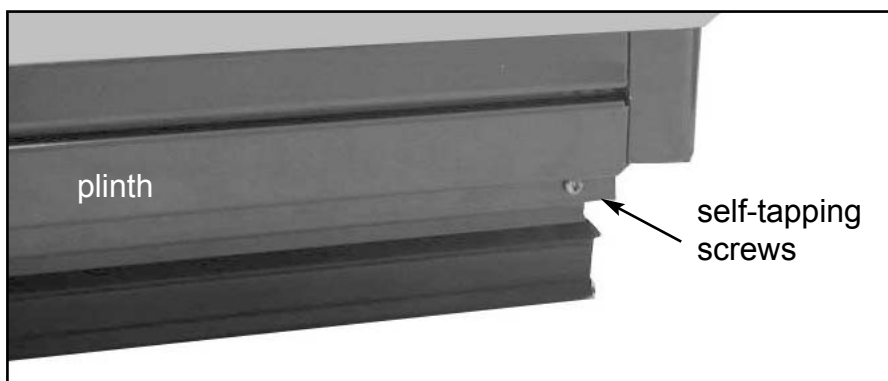

COSTAN TECHNICAL DOCUMENTATION	CHAPTER REVISION STATUS				DOC. N° QSM000165E N° CAP. 10	PAGE: 9/9
	ORD.	DATE	ORD.	DATE		
PRODUCT: AERIA N/L 15	A		D		IN CONFORMITY WITH APPROVED ORIGINAL	DATE OF 1st ISSUE: 10.May.04
CHAPTER: MULTIPLEXING CABINETS	B		E			
	C		F			

ASSEMBLY OF SIDE PLINTHS

Place the plastic plinth (1), bend the rear part of the support backwards (2) and fit it onto the rear of the cabinet (3); then bend the fore part of the support's tongue inwards by 90° (4), drill and secure using self-tapping screws (5).

