

MAKING MODERN LIVING POSSIBLE

Danfoss



Green technology – with Danfoss CO₂ Solutions

REFRIGERATION &
AIR CONDITIONING DIVISION

Products for CO₂ in
Industrial Refrigeration
systems

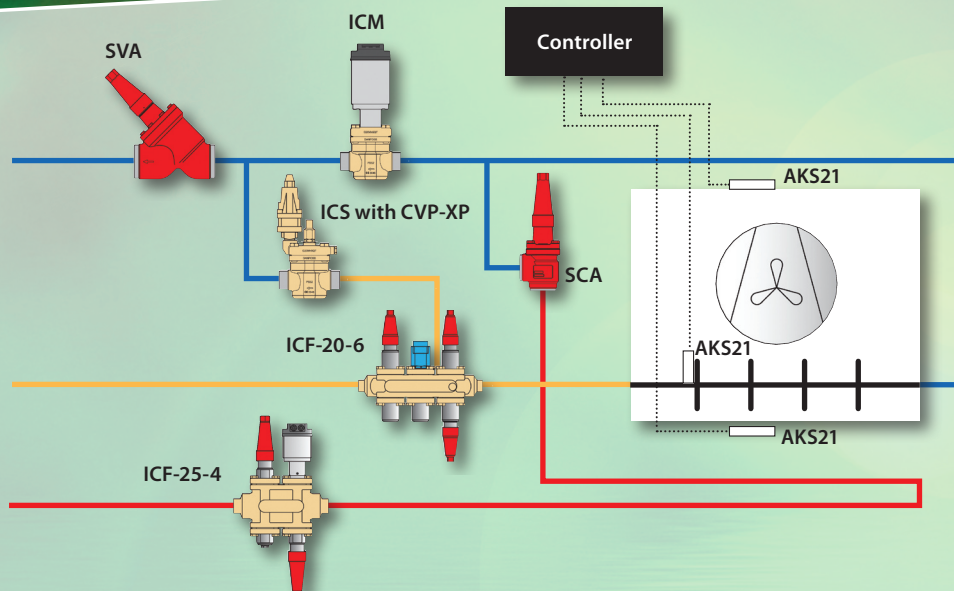

Products for CO₂ in
Food Retail Refrigeration
transcritical systems

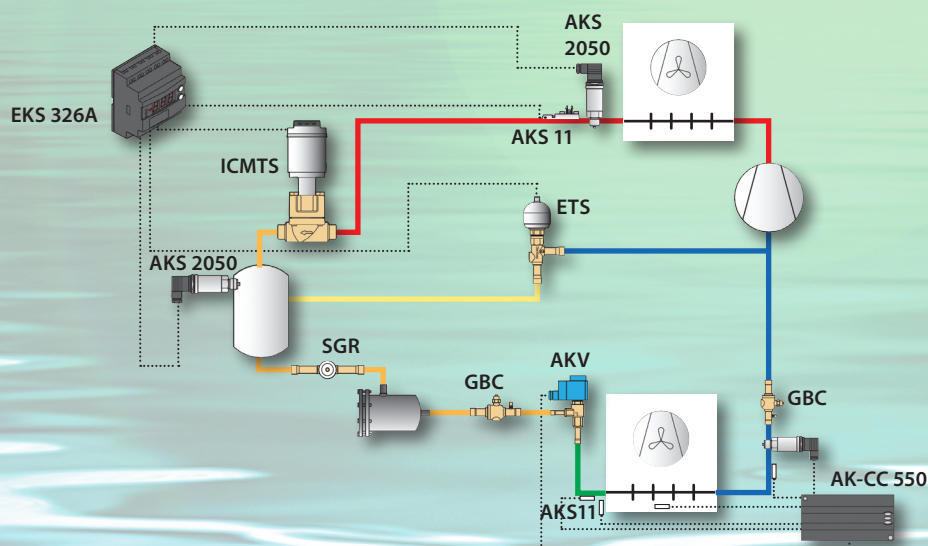

Products for CO₂ in
Light commercial refrigeration
systems

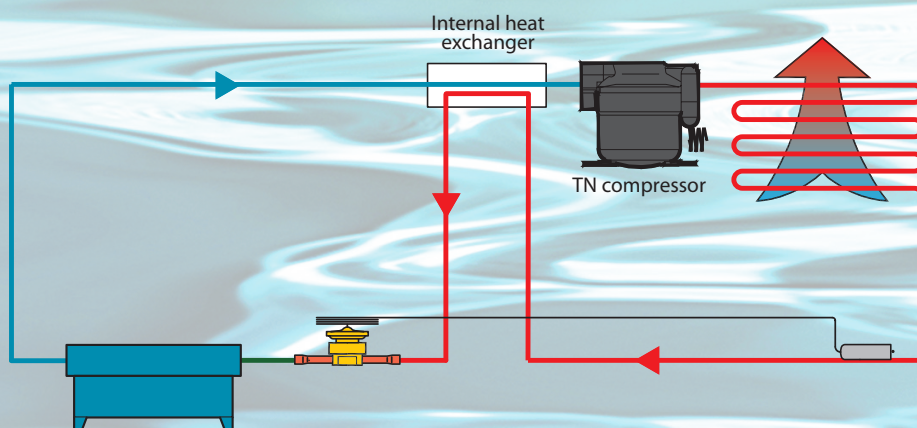

Danfoss refrigeration products for Industrial Refrigeration
– CO₂ sub-critical systems:

- Servo operated main valves (**ICS**)
- Motorized control valves (**ICM**)
- Control solutions (**ICF**)
- Line Components
- Stop valves (**SVA-ST**)
- Stop-check and check valves (**SCA** and **CHV**)
- Regulating valves (**REG**)
- Filters (**FIA**)
- Safety valves (**SFA**)
- Double stop valves (**DSV**)
- Solenoid valves (**EVRS**)
- Sensors and transmitters
- Liquid level transmitters (**AKS 41**)
- Gas detection sensors (**GD**)
- Pressure transmitters (**AKS 3000**)



AKS41-AKS3000



ICF



ICS+CVP-XP



SVA-ST, SCA and FIA

Danfoss refrigeration products for small stores, supermarkets and hypermarkets
– CO₂ cascade and transcritical systems:

- Gas Cooler Pressure Controls (**ICMTS**)
- Line Components
- Ball valves (**GBC**)
- Check valves (**NRV**)
- Filter driers (**DCR**)
- Solenoid valves (**EVRH**)
- Pulse modulating expansion valves (**AKV**)
- Electronic Controls
- Full store system controllers (**AK-SC 255**)
- Pack controllers (**AK-PC 730**)
- Controllers to regulate CO₂ gas cooling (**EKC 326A**)
- Evaporator controllers **AK-CC 550**
- Pressure transmitters (**AKS 3000** and **AKS 2050**)
- Stepper motor expansion valves (**ETS**)



ICMTS



AKV

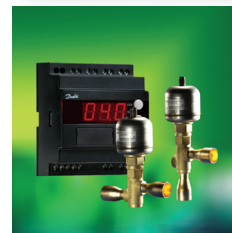

EKC 326A and ETS



AK-SC 255, AK-PC 730
and AK-CC 550

Danfoss refrigeration products for light commercial applications
– CO₂ transcritical systems:

- Compressor (**TN**)
- Thermostatic back pressure regulators (**TBR**)
- Electronic Controls and sensors
- Controllers to regulate CO₂ gas cooling (**EKC 326A**)



TN-Compressor



TBR



EKC 326



AKS 2050



Danfoss – Your CO₂ Solution Provider

Danfoss offers a complete range of valves for cascade CO₂ systems

Complete ADAP-KOOL® system control solutions

Danfoss has more than 15 years of experience in developing
sub-critical and trans-critical CO₂ systems

Danfoss has carried out a number of tests to ensure that components
released for use with CO₂ can withstand the impact of CO₂ in all aspects.

Read more about Danfoss CO₂ products and solutions

– visit us at www.danfoss.com/CO2