

Maintenance Manual

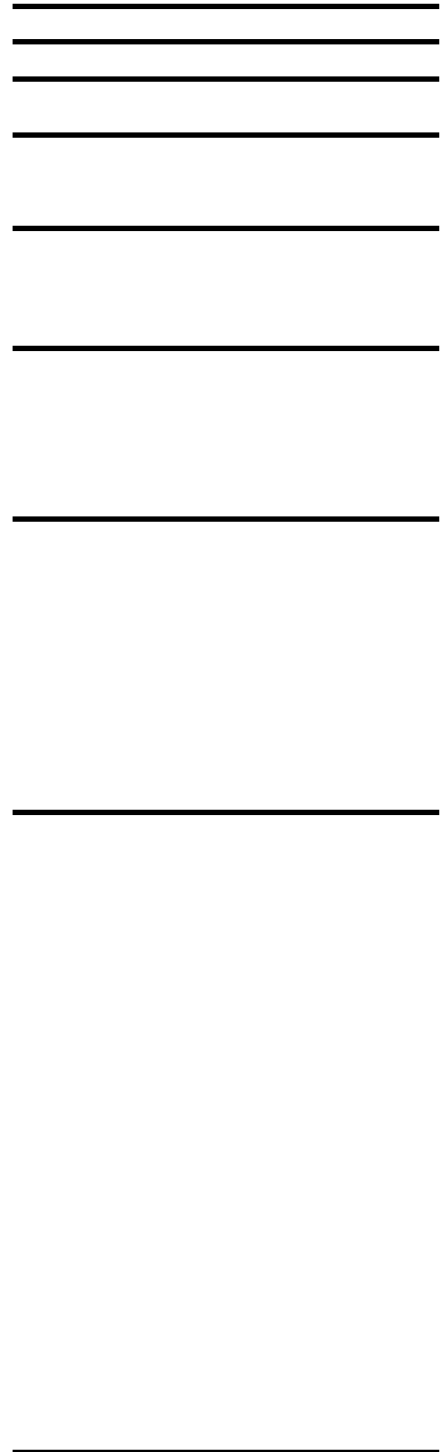

CRR-20 & CRR-40 with μ P-D

TK50094-4-MM (Rev. 5, 9/99)



This manual is published for informational purposes only and the information so provided should not be considered as all-inclusive or covering all contingencies. If further information is required, Thermo King Corporation should be consulted.

Sale of product shown in this Manual is subject to Thermo King's terms and conditions including, but not limited to, the THERMO KING EXPRESS WARRANTY. Such terms and conditions are available upon request.

Thermo King's warranty will not apply to any equipment which has been "so repaired or altered outside the manufacturer's plants as, in the manufacturer's judgment, to effect its stability."

No warranties, express or implied, including warranties of fitness for a particular purpose or merchantability, or warranties arising from course of dealing or usage of trade, are made regarding the information, recommendations, and descriptions contained herein. Manufacturer is not responsible and will not be held liable in contract or in tort (including negligence) for any special, indirect or consequential damages, including injury or damage caused to vehicles, contents or persons, by reason of the installation of any Thermo King product or its mechanical failure.

Smart Reefer and Thermoguard are trademarks of Thermo King Corporation. All other trademarks are the property of their respective owners.

Recover Refrigerant

At Thermo King we recognize the need to preserve the environment and limit the potential harm to the ozone layer that can result from allowing refrigerant to escape into the atmosphere.

We strictly adhere to a policy that promotes the recovery and limits the loss of refrigerant into the atmosphere.

In addition, service personnel must be aware of Federal regulations concerning the use of refrigerants and the certification of technicians. For additional information on regulations and technician certification programs, contact your local THERMO KING dealer.

Table of Contents

<hr/>			
Introduction	v	System Net Heating Capacity	1-2
About This Manual	v	CRR-20SL & CRR-40 Models	1-2
Other Reference Manuals	v	Evaporator Airflow	1-3
CRR Model Features	vi to x	CRR-40 Models with Three Evaporator Fans	1-3
<hr/>		High Performance Airflow Option for CRR-40 Models with Three Evaporator Fans	1-3
Safety Precautions	xi	CRR-40 Models with Two Evaporator Fans	1-3
General Practices	xi	CRR-20SL Models with Three Evaporator Fans	1-3
Refrigerant	xi	Refrigeration System	1-4
Refrigerant Oil	xii	Normal R-134a System Operating Pressures	1-5
Electrical	xii	Thermoguard® µP-D Controller	1-6
General Safety Practices for Servicing Units (or Containers) Equipped with a Microprocessor Controller	xiii	Electrical System	1-8
Unit Decals	xiv	Dehumidify and Humidify Systems (Options)	1-9
Serial Number Locations	xiv	Physical Specifications	1-9
<hr/>		Compressor Torque Chart	1-11
Service Guide	xv	Metric Hardware Torque Charts	1-12
<hr/>		Unit Description	2-1
Specifications	1-1	General Description	2-1
System Net Cooling Capacity – Full Cool	1-1	Operating Modes	2-3
CRR-40 Models with Three Evaporator Fans – Air Cooled Condensing	1-1	Unit Illustrations	2-5
CRR-40 Models with Two Evaporator Fans – Air Cooled Condensing	1-1	Typical Unit Front View	2-5
CRR-20SL Models with Three Evaporator Fans – Air Cooled Condensing	1-1	Unit Options Front View	2-6
CRR-40 Models with Three Evaporator Fans – Water Cooled Condensing Option with 37.8 C (100 F) Water Temperature	1-2	Evaporator Section for Models with Three Evaporator Fans – Front View	2-7
CRR-40 Models with Three Evaporator Fans – Water Cooled Condensing Option with 30 C (86 F) Water Temperature	1-2	Evaporator Section for Models with Two Evaporator Fans – Front View	2-8
		Standard Refrigeration System	2-9
		Refrigeration System Options	2-10
		Control Box – Door Open	2-11
		Sabroe or RTE Remote Monitor Modem Option for Power Line Communications	2-12
		Dual Voltage Option	2-13
		Auxiliary Battery and Battery Charger Option	2-14
		TRANSFRESH System Option	2-15
		Humidify System Option	2-16
		Typical Unit Back View	2-17

Operating Instructions	3-1	Displaying Alternate Controlling (Supply or Return) Air Sensor Temperatures	4-18
Unit Controls	3-1	Changing the Setpoint	4-18
Unit Instruments	3-2	Initiating a Manual Defrost	4-19
Unit Protection Devices	3-3	Initiating a Full Pretrip	4-19
Pretrip Inspection	3-4	Entering a Start of Trip Marker	4-20
Starting the Unit and Adjusting the Setpoint	3-6	Displaying and Clearing Alarm Codes	4-20
Loading Procedure	3-6	Controller Menu Operating Instructions	4-21
Post Load Procedure	3-6	Menu View Functions	4-21
Post Trip Procedure	3-6	Navigating the Menu View Screens	4-21
		GRADE Submenu	4-22
		LOG Submenu	4-22
		Menu Pretrip Functions	4-25
		Performing an Extended, Full or Single Pretrip Test from the Pretrip Menu	4-26
		Menu Test Functions	4-27
		Menu Guard Functions	4-29
		Navigating Menu Guard Screens	4-29
		Setting the Unit Configuration and Customer Configuration Numbers	4-30
		Setting the Container Identification Number	4-30
		Setting the Unit Serial Number	4-31
		Setting the Time and Date	4-31
		Setting the Compressor and On Time Hourmeters	4-32
		Setting the User Hourmeter Types, User Hourmeter Thresholds and User Hourmeters	4-32
		Setting the Sensor Grades	4-33
		Changing the Display Units (C/F)	4-35
		Menu Program Functions	4-36
		USDA Sensors	4-36
		PULP Sensor (Option)	4-37
		Economy Mode	4-38
		Dehumidify Mode (Option)	4-39
		Humidify Mode (Option)	4-39
		Bulb Mode (Option)	4-40
		Power Reduction Mode	4-41
		Controller Emergency Bypass Procedure	4-42
		Output Module	4-43
		Thermo Bus Tap	4-43
		Power Module	4-43
		Replacing the μ P-D Controller	4-44
		Temperature Sensors	4-44
		Diagnosis and Repair	4-45
		Alarm Codes, Descriptions and Corrective Actions	4-46 to 4-64
μP-D Controller	4-1		
General Description	4-1		
Controller Display Menus	4-3		
Software Version Display	4-3		
Active Option Displays	4-3		
Pause Mode Displays	4-4		
View Menu	4-4		
Pretrip Menu	4-4		
Test Menu	4-4		
Guarded Access Menu	4-4		
Program Menu	4-4		
Menu Display Definitions	4-4		
Status Indicator LEDs and Alarm Codes	4-6		
Pause Alarms	4-7		
Data Logging and Downloading Data	4-8		
General Theory of Operation	4-8		
Chill Loads	4-8		
Frozen Loads	4-8		
Automatic Phase Selection	4-9		
Compressor Soft Start Sequence	4-9		
Compressor Liquid Injection	4-9		
KVQ Setting (PCCAP)	4-9		
Evaporator Fan Control	4-9		
Condenser Fan Control	4-9		
Sensor Check	4-10		
Power Limit	4-10		
Economy Mode Operation	4-11		
Sequence of Operation	4-11		
Unit Start-up	4-11		
Operating Mode Function Chart — Standard Operation	4-12		
Operating Mode Function Chart — Optional Feature Operation	4-13		
Continuous Temperature Control Operation	4-13		
Defrost	4-16		
Reviewing Software Version and Configuration	4-17		
Displaying Alternate Fahrenheit (F) or Celsius (C) Temperatures	4-17		

Electrical Maintenance	5-1	Partlow (Model SR) Recording Thermo-	
Unit Wiring	5-1	meter (Option)	7-3
Auxiliary Battery and Battery Charger (Option)	5-1	Recording Chart Replacement	7-3
High Pressure Cutout Switch	5-1	Recording Stylus Calibration	7-3
Condenser Fan and Evaporator Fan Rotation	5-2	Element Replacement	7-4
Electric Heaters	5-3	Saginomiya (Model SKM) Recording Thermo-	
		meter (Option)	7-4
		Battery	7-4
		Recording Chart Replacement	7-5
		Recording Stylus Calibration	7-5
		Power Element Assembly Replacement	7-6
		Timer (Quartz Motor and Reducing Gear	
		Replacement	7-6
		Battery Voltage Indicator	7-6
		Humidify System (Option)	7-7
		Pretrip Inspection	7-7
		Inspection and Cleaning	7-7
Refrigeration Maintenance and Service Operations	6-1	Diagnosis	8-1
Service Tools	6-1	Mechanical Diagnosis	8-1
Compressor Discharge and Suction Service Valves	6-2	Refrigeration Diagnosis	8-5
Gauge Manifold Valve Positions	6-3		
Gauge Manifold Set Attachment and Purging	6-4	Electrical, Refrigeration and μP-D Menu	
Checking Compressor Oil	6-5	Flow Diagrams	9-1
Refrigerant Leak Test Procedure	6-6	Electrical Schematic with Circuit Tracing	9-1 to 9-24
Low Side Pump Down	6-7	460/380 Vac Power Supply to Unit	9-1
Refrigerant Charge	6-7	230/190 Vac Power Supply to Unit	9-2
Evacuation and Cleanup of the Refrigeration System	6-9	External 12 Vdc Battery Power Supply	9-3
Evaporator Pressure Regulator (KVQ) Valve	6-13	Microprocessor Awakened from Sleep Mode	9-4
Refrigerant Recovery	6-15	12.5 Vdc Control Circuit, Sensor Circuits,	
Using Pressurized Nitrogen	6-16	Evaporator Pressure Regulator (KVQ)	
Compressor Replacement	6-17	Valve Circuit, Condenser Fan Pressure	
Condenser Coil Replacement	6-18	Switch Circuit and Water Pressure	
Dehydrator (Filter Drier) or In-line Filter Replacement	6-18	Circuit (Option)	9-5
Expansion Valve Replacement	6-19	24 Vac Control Circuit	9-6
Heat Exchanger Replacement	6-19	Setpoint Enable Battery and Battery	
Receiver Tank Replacement	6-20	Charger Circuit (Option)	9-7
High Pressure Cutout Switch, Condenser Fan Speed Switch or Compressor Discharge Gas Temperature Sensor Replacement	6-20	Remote Monitor Receptacle (4-pin) for	
Liquid Line Solenoid Valve	6-21	Bridge Lights Circuit (Option)	9-8
Liquid Injection Valve Replacement	6-21	TRANSFRESH® Atmosphere Control	
Dehumidify Valve (Option) Replacement	6-22	System Circuit (Option)	9-9
		Integrated Remote Monitor System	
Structural/Accessory Maintenance	7-1	Circuit (Option)	9-10
Mounting Bolts	7-1	Dehumidify System, Humidity System,	
Unit Inspection	7-1	Water Pressure Switch, USDA	
Condenser Coil	7-1	Temperature Sensor, Pulp Sensor and	
Evaporator Coil	7-1	Chart Recorder Circuits (Options)	9-11
Defrost Drains	7-2		
Evaporator Fan Location	7-2		
Condenser Fan Location	7-2		
Fresh Air Exchange System	7-2		

Cool Mode – Chill Load (Setpoint at -9.9 C [14.1 F] or Above); Water-Cooled Condenser Operation; Power Monitor Limiting Unit Power Consumption; Economy Mode OFF	9-12	Null Mode – Chill Load (Setpoint at -9.9 C [14.1 F] or Above) After Compressor Pump Down; Economy Mode OFF	9-22
Cool Mode – Chill Load (Setpoint at -9.9 C [14.1 F] or Above); Condenser Fan ON; Power Monitor Limiting Unit Power Consumption; Economy Mode OFF	9-13	Heat Mode – Chill Load (Setpoint at -9.9 C [14.1 F] or Above); Economy Mode OFF; Temperature In-range	9-23
Cool Mode – Chill Load (Setpoint at -9.9 C [14.1 F] or Above); Condenser Fan ON; Economy Mode OFF	9-14	Cool Mode – Frozen Load (Setpoint at -10.0 C [14.0 F] or Below); Condenser Fan ON; Container Return Air Temperature Above -10.0 C [14.0 F]; Power Monitor Limiting Unit Power Consumption; Economy Mode OFF	9-24
Cool Mode – Chill Load (Setpoint at -9.9 C [14.1 F] or Above); Condenser Fan ON; Economy Mode OFF; Humidify Mode (Option) ON with container humidity above humidity setpoint	9-15	Cool Mode – Frozen Load (Setpoint at -10.0 C [14.0 F] or Below); Condenser Fan ON; Container Return Air Temperature Below -10.0 C [14.0 F]; Economy Mode OFF; Temperature In-range	9-25
Cool Mode – Chill Load (Setpoint at -9.9 C [14.1 F] or Above); Condenser Fan ON; Economy Mode OFF; Humidify Mode (Option) ON with container humidity more than 2% below the humidity setpoint	9-16	Null Mode – Frozen Load (Setpoint at -10.0 C [14.0 F] or Below) After Compressor Pump Down; Economy Mode OFF	9-26
Modulation Mode – Chill Load (Setpoint at -9.9 C [14.1 F] or Above); Condenser Fan ON; Economy Mode OFF; Temperature Out-of-range	9-17	Null Mode – Frozen Load (Setpoint at -10.0 C [14.0 F] or Below) After Compressor Pump Down; Economy Mode ON	9-27
Modulation Mode – Chill Load (Setpoint at -9.9 C [14.1 F] or Above); Condenser Fan ON; Economy Mode OFF; Temperature In-range; Dehumidify ON with Humidity 1-5% Above Humidity Setpoint	9-18	Defrost	9-28
Modulation Mode – Chill Load (Setpoint at -9.9 C [14.1 F] or Above); Condenser Fan ON; Economy Mode OFF; Temperature In-range; Dehumidify ON with Humidity 5% or More Above Humidity Setpoint	9-19	CRR-20SL & CRR-40 (All Models Except CRR-40-133 & CRR-40-139) Wiring Schematic	9-29
Modulation Mode – Chill Load (Setpoint at -9.9 C [14.1 F] or Above); Condenser Fan OFF; Economy Mode ON; Temperature In-range	9-20	CRR-20SL & CRR-40 (All Models Except CRR-40-133 & CRR-40-139) Wiring Diagram	9-30 to 9-32
Null Mode – Chill Load (Setpoint at -9.9 C [14.1 F] or Above) During Compressor Pump Down (Condenser Fan ON); Economy Mode OFF	9-21	CRR-40-133 & CRR-40-139 Wiring Schematic	9-33
		CRR-40-133 & CRR-40-139 Wiring Diagram	9-34 to 9-36
		Refrigeration System Schematics:	
		Refrigeration System Components	9-37
		Full Cool Flow and Pressure Diagram	9-38
		Modulation Cool Flow and Pressure Diagram	9-39
		Dehumidification Flow and Pressure Diagram	9-40
		µP-D Menu Flow Diagram	9-41

Introduction

About This Manual

The information in this manual is provided to assist owners, operators and service people in the proper upkeep and maintenance of Thermo King units. The maintenance information in this manual covers unit models:

CRR Models with Three Evaporator Fans

CRR-40-52
CRR-40-54
CRR-20SL-63
CRR-40-100
CRR-40-101
CRR-40-102
CRR-40-103
CRR-40-106
CRR-40-107
CRR-40-110
CRR-40-111
CRR-40-112
CRR-40-113
CRR-40-114
CRR-40-116
CRR-40-117
CRR-40-121
CRR-40-123
CRR-20SL-125
CRR-40-126
CRR-40-128
CRR-40-130
CRR-40-131
CRR-40-132
CRR-40-138
CRR-40-142
CRR-40-143
CRR-40-144
CRR-40-145

CRR Models with Two Evaporator Fans

CRR-40-133
CRR-40-136
CRR-40-139
CRR-40-141
CRR-40-147
CRR-40-148
CRR-40-150
CRR-40-151

Other Reference Manuals

For detailed descriptions of our refrigeration systems or microprocessor controllers, see the appropriate manual or Thermoguard μ P-D Microprocessor Controller Diagnosis Manual. For further information refer to:

Parts Manuals

CRR-40 & CRR-20 with μ P-D Parts List*	TK50193
CRR-40 & CRR-20 μ P-D for Hapag-Lloyd Parts List*	TK50469
CRR P & O Parts List**	TK50528

Operation, Diagnosis and Refrigeration Maintenance Manuals

Diagnosing Thermo King Container Refrigeration Systems	TK 41166
Electrostatic Discharge (ESD) Training Guide	TK 40282
Evacuation Station Operation and Field Application	TK 40612
PC-PAC™ Software Manual	P/N 204-988
Thermoguard® μ P-D Microprocessor Controller Operation and Diagnosis Manual	TK 41230
Tool Catalog	TK 5955

*Models with three evaporator fans.

**Models with two evaporator fans.

CRR Model Features

CRR-40-52	CRR-40-54	CRR-20SL-63	CRR-40-100	CRR-40-101	CRR-40-102	CRR-40-103	CRR-40-106	CRR-40-107	MODEL	FEATURES X = Included
X	X	X	X	X	X	X	X	X		460-380V/3Ph/60-50 Hz, 18.3 m (60 ft) Power Cable and Plug
-	-	-	X	-	X	-	-	X		Dual Voltage Feature: 15 kVA Autotransformer with 460-380V Power Receptacle and 230-190V/3Ph/60-50 Hz, 18.3 m (60 ft) Power Cable and Plug
X	X	X	X	X	X	X	X	X		Automatic Phase Selection Control
X	X	X	X	X	X	X	X	X		25 Amp Main Power Circuit Breaker
-	-	X	-	-	-	-	-	-		Slimline Frame
X	X	-	X	X	X	X	X	X		3DS Copeland Discus Compressor w/5.60 kW (7.5 Hp) Motor
-	-	X	-	-	-	-	-	-		3DF Copeland Discus Compressor w/5.60 kW (7.5 Hp) Motor
X	X	X	X	X	X	X	X	X		Compressor Liquid Injection System
X	X	X	X	X	X	X	X	X		Suction and Discharge Line Service Valves
X	X	X	X	X	X	X	X	X		Evaporator Pressure Regulator (KVQ Valve)
X	X	X	X	X	X	X	X	X		Refrigerant R-134a w/Polyol Ester Compressor Oil (TK P/N 203-433)
X	X	X	X	X	X	X	X	X		Receiver Tank with Moisture Indicating Sight Glass
X	X	X	X	X	X	X	X	X		µP-D Controller with Proportional-integral Differential (PID) Capacity Control
X	X	X	X	X	X	X	X	X		Controller Emergency Bypass Module
X	X	X	X	X	X	X	X	X		USDA Cold Treatment Temperature Recording
X	X	X	X	X	X	X	X	X		Three Evaporator Fans with 2-Speed Motors
X	X	X	X	X	X	X	X	X		Fresh Air Exchange System
X	X	X	X	X	X	X	X	X		CO ₂ Sampling Port
X	X	X	X	X	X	X	X	X		One 1-Speed Condenser Fan Motor
-	-	X	X	X	-	-	-	-		Auxiliary Battery and Battery Charger
-	X	-	-	-	-	-	-	-		Bulb Mode Operation
-	-	-	-	-	-	-	-	X		Controlled Atmosphere System
X	-	X	X	X	X	-	X	X		Data Retrieval Receptacle, Standard (5-Pin Duetsch)
-	X	-	-	-	-	X	-	-		Data Retrieval Receptacle, 5-Pin Threaded Cannon
-	-	-	-	-	-	-	-	-		Data Retrieval Receptacle, 15-Pin RS232
X	X	-	-	-	-	X	-	-		Dehumidify Control
-	-	-	-	-	-	X	-	-		High Output Evaporator Airflow
-	-	-	-	-	-	-	-	-		Humidity System
-	-	-	-	-	-	-	-	-		Power Line Communications , Standard (Thermo King Modem)
-	-	-	-	-	-	-	-	-		Power Line Communications , RTE Modem
-	-	-	-	-	-	-	-	X		Power Line Communications , Sabroe Control Modem
X	-	-	-	-	-	-	-	-		Pressure Gauge, Discharge
X	-	-	X	-	-	-	-	-		Pressure Gauge, Suction
-	-	-	X	-	-	-	-	X		Recorder, Partlow
-	-	-	-	-	-	-	-	-		Recorder, Saginomiya
-	-	-	-	-	-	-	-	X		Redundant Supply and Return Sensors
-	X	X	-	X	-	X	X	-		Remote Monitoring Plug (4-Pin)
-	-	X	-	X	-	X	-	-		TRANSFRESH® Provision
-	-	-	-	-	-	-	-	X		TRANSFRESH® Purge Port
-	-	-	X	-	-	-	-	X		TRANSFRESH® System, Complete
-	X	-	X	X	-	X	-	-		Thermistor Lead
-	-	-	-	-	-	-	X	-		Water-Cooled Condenser-Receiver Tank with Moisture Indicating Sight Glass

CRR Model Features (Continued)

CRR-40-110	CRR-40-111	CRR-40-112	CRR-40-113	CRR-40-114	CRR-40-116	CRR-40-117	CRR-40-121	CRR-40-123	MODEL	FEATURES X = Included
X	X	X	X	X	X	X	X	X	460-380V/3Ph/60-50 Hz, 18.3 m (60 ft) Power Cable and Plug	
-	X	-	X	-	X	-	-	-	Dual Voltage Feature: 15 kVA Autotransformer with 460-380V Power Receptacle and 230-190V/3Ph/60-50 Hz, 18.3 m (60 ft) Power Cable and Plug	
X	X	X	X	X	X	X	X	X	Automatic Phase Selection Control	
X	X	X	X	X	X	X	X	X	25 Amp Main Power Circuit Breaker	
-	-	-	-	-	-	-	-	-	Slimline Frame	
X	X	X	X	X	X	X	X	X	3DS Copeland Discus Compressor w/5.60 kW (7.5 Hp) Motor	
-	-	-	-	-	-	-	-	-	3DF Copeland Discus Compressor w/5.60 kW (7.5 Hp) Motor	
X	X	X	X	X	X	X	X	X	Compressor Liquid Injection System	
X	X	X	X	X	X	X	X	X	Suction and Discharge Line Service Valves	
X	X	X	X	X	X	X	X	X	Evaporator Pressure Regulator (KVQ Valve)	
X	X	X	X	X	X	X	X	X	Refrigerant R-134a w/Polyol Ester Compressor Oil (TK P/N 203-433)	
X	X	X	X	X	X	X	X	X	Receiver Tank with Moisture Indicating Sight Glass	
X	X	X	X	X	X	X	X	X	µP-D Controller with Proportional-integral Differential (PID) Capacity Control	
X	X	X	X	X	X	X	X	X	Controller Emergency Bypass Module	
X	X	X	X	X	X	X	X	X	USDA Cold Treatment Temperature Recording	
X	X	X	X	X	X	X	X	X	Three Evaporator Fans with 2-Speed Motors	
X	X	X	X	X	X	X	X	X	Fresh Air Exchange System	
X	X	X	X	X	X	X	X	X	CO ₂ Sampling Port	
X	X	X	X	X	X	X	X	X	One 1-Speed Condenser Fan Motor	
-	-	-	-	-	-	X	-	-	Auxiliary Battery and Battery Charger	
-	-	-	-	-	-	-	-	-	Bulb Mode Operation	
-	-	-	-	-	-	-	-	-	Controlled Atmosphere System	
X	X	-	X	X	X	X	X	X	Data Retrieval Receptacle, Standard (5-Pin Duetsch)	
-	-	X	-	-	-	-	-	-	Data Retrieval Receptacle, 5-Pin Threaded Cannon	
-	-	-	-	-	-	-	-	-	Data Retrieval Receptacle, 15-Pin RS232	
X	-	-	-	-	-	-	-	-	Dehumidify Control	
-	-	-	-	-	-	-	-	-	High Output Evaporator Airflow	
-	-	-	-	-	-	-	-	-	Humidity System	
-	-	-	-	-	-	-	-	-	Power Line Communications , Standard (Thermo King Modem)	
-	-	-	-	-	-	-	-	-	Power Line Communications , RTE Modem	
X	-	-	-	-	-	-	-	-	Power Line Communications , Sabroe Control Modem	
-	-	-	-	-	-	-	-	-	Pressure Gauge, Discharge	
-	-	-	X	-	-	-	-	-	Pressure Gauge, Suction	
-	X	X	-	X	-	-	X	X	Recorder, Partlow	
X	-	-	-	-	-	-	-	-	Recorder, Saginomiya	
-	-	-	-	-	-	-	-	-	Redundant Supply and Return Sensors	
X	X	-	-	X	-	-	-	-	Remote Monitoring Plug (4-Pin)	
-	-	-	-	X	-	-	-	-	TRANSFRESH® Provision	
-	-	-	-	X	-	-	X	-	TRANSFRESH® Purge Port	
-	-	-	-	-	-	-	X	-	TRANSFRESH® System, Complete	
-	X	-	-	-	-	-	-	-	Thermistor Lead	
-	-	-	-	-	-	-	-	-	Water-Cooled Condenser-Receiver Tank with Moisture Indicating Sight Glass	

CRR Model Features (Continued)

CRR-20SL-125	CRR-40-126	CRR-40-128	CRR-40-130	CRR-40-131	CRR-40-132	CRR-40-133	CRR-40-136	CRR-40-138	MODEL	FEATURES X = Included
X	X	X	X	X	X	X*	X*	X		460-380V/3Ph/60-50 Hz, 18.3 m (60 ft) Power Cable and Plug
-	-	X	-	-	-	-	-	-		Dual Voltage Feature: 15 kVA Autotransformer with 460-380V Power Receptacle and 230-190V/3Ph/60-50 Hz, 18.3 m (60 ft) Power Cable and Plug
X	X	X	X	X	X	X	X	X		Automatic Phase Selection Control
X	X	X	X	X	X	X	X	X		25 Amp Main Power Circuit Breaker
X	-	-	-	-	-	-	-	-		Slimline Frame
-	X	X	X	X	X	X	X	X		3DS Copeland Discus Compressor w/5.60 kW (7.5 Hp) Motor
X	-	-	-	-	-	-	-	-		3DF Copeland Discus Compressor w/5.60 kW (7.5 Hp) Motor
X	X	X	X	X	X	X	X	X		Compressor Liquid Injection System
X	X	X	X	X	X	X	X	X		Suction and Discharge Line Service Valves
X	X	X	X	X	X	X	X	X		Evaporator Pressure Regulator (KVQ Valve)
X	X	X	X	X	X	X	X	X		Refrigerant R-134a w/Polyol Ester Compressor Oil (TK P/N 203-433)
X	X	X	X	X	X	X	X	X		Receiver Tank with Moisture Indicating Sight Glass
X	X	X	X	X	X	X	X	X		µP-D Controller with Proportional-integral Differential (PID) Capacity Control
X	X	X	X	X	X	X	X	X		Controller Emergency Bypass Module
X	X	X	X	X	X	X	X	X		USDA Cold Treatment Temperature Recording
X	X	X	X	X	X	-	-	X		Three Evaporator Fans with 2-Speed Motors
-	-	-	-	-	-	X	X	-		Two Evaporator Fans with 2-Speed Motors
X	X	X	X	X	X	X	X	X		Fresh Air Exchange System
X	X	X	X	X	X	X	X	X		CO ₂ Sampling Port
X	X	X	X	X	X	X	X	X		One 1-Speed Condenser Fan Motor
X	X	-	-	-	-	-	-	X		Auxiliary Battery and Battery Charger
-	-	-	-	-	-	-	-	-		Bulb Mode Operation
-	-	-	-	-	-	-	-	-		Controlled Atmosphere System
X	X	X	X	X	X	-	-	X		Data Retrieval Receptacle, Standard (5-Pin Duetsch)
-	-	-	-	-	-	X	X	-		Data Retrieval Receptacle, 5-Pin Threaded Cannon
-	-	-	-	-	-	-	-	-		Data Retrieval Receptacle, 15-Pin RS232
-	-	-	-	X	X	X	X	-		Dehumidify Control
-	-	-	-	-	-	-	-	-		High Output Evaporator Airflow
-	-	-	-	-	-	-	X	-		Humidity System
-	-	-	-	-	-	-	-	-		Power Line Communications, Standard (Thermo King Modem)
-	-	-	-	-	-	-	-	-		Power Line Communications, RTE Modem
-	-	-	-	-	-	-	-	X		Power Line Communications, Sabroe Control Modem
-	-	-	-	-	-	-	-	-		Pressure Gauge, Discharge
-	-	-	-	-	-	-	-	-		Pressure Gauge, Suction
-	-	-	-	X	X	-	-	X		Recorder, Partlow
-	-	-	X	-	-	-	-	-		Recorder, Saginomiya
-	-	-	-	-	-	-	-	-		Redundant Supply and Return Sensors
X	X	-	X	-	-	X	X	-		Remote Monitoring Plug (4-Pin)
-	-	X	X	-	-	X	X	-		TRANSFRESH® Provision
-	-	X	-	-	-	-	-	-		TRANSFRESH® Purge Port
-	-	-	-	-	-	-	-	-		TRANSFRESH® System, Complete
X	X	-	-	-	-	X	X	-		Thermistor Lead
-	-	-	-	-	-	-	-	-		Water-Cooled Condenser-Receiver Tank with Moisture Indicating Sight Glass

*21.3 m (70 ft) power cable.

CRR Model Features (Continued)

CRR-40-139	CRR-40-141	CRR-40-142	CRR-40-143	CRR-40-144	CRR-40-145	CRR-40-147	CRR-40-148	CRR-40-150	MODEL	FEATURES X = Included
X	X	X	X	X	X	X	X	X	460-380V/3Ph/60-50 Hz, 18.3 m (60 ft) Power Cable and Plug	
-	-	-	X	X	X	-	-	-	Dual Voltage Feature: 15 kVA Autotransformer with 460-380V Power Receptacle and 230-190V/3Ph/60-50 Hz, 18.3 m (60 ft) Power Cable and Plug	
X	X	X	X	X	X	X	X	X	Automatic Phase Selection Control	
X	X	X	X	X	X	X	X	X	25 Amp Main Power Circuit Breaker	
-	-	-	-	-	-	-	-	-	Slimline Frame	
X	X	X	X	X	X	X	X	X	3DS Copeland Discus Compressor w/5.60 kW (7.5 Hp) Motor	
-	-	-	-	-	-	-	-	-	3DF Copeland Discus Compressor w/5.60 kW (7.5 Hp) Motor	
X	X	X	X	X	X	X	X	X	Compressor Liquid Injection System	
X	X	X	X	X	X	X	X	X	Suction and Discharge Line Service Valves	
X	X	X	X	X	X	X	X	X	Evaporator Pressure Regulator (KVQ Valve)	
X	X	X	X	X	X	X	X	X	Refrigerant R-134a w/Polyol Ester Compressor Oil (TK P/N 203-433)	
X	X	X	X	X	X	X	X	X	Receiver Tank with Moisture Indicating Sight Glass	
X	X	X	X	X	X	X	X	X	µP-D Controller with Proportional-integral Differential (PID) Capacity Control	
X	X	X	X	X	X	X	X	X	Controller Emergency Bypass Module	
X	X	X	X	X	X	X	X	X	USDA Cold Treatment Temperature Recording	
-	-	X	X	X	X	-	-	-	Three Evaporator Fans with 2-Speed Motors	
X	X	-	-	-	-	X	X	X	Two Evaporator Fans with 2-Speed Motors	
X	X	X	X	X	X	X	X	X	Fresh Air Exchange System	
X	X	X	X	X	X	X	X	X	CO ₂ Sampling Port	
X	X	X	X	X	X	X	X	X	One 1-Speed Condenser Fan Motor	
-	-	-	-	-	-	-	-	X	Auxiliary Battery and Battery Charger	
-	-	-	-	-	-	-	-	-	Bulb Mode Operation	
-	-	-	-	-	-	-	X	-	Controlled Atmosphere System	
X	X	X	-	X	X	X	X	X	Data Retrieval Receptacle, Standard (5-Pin Duetsch)	
-	-	-	X	-	-	-	-	-	Data Retrieval Receptacle, 5-Pin Threaded Cannon	
-	-	-	-	-	-	-	-	-	Data Retrieval Receptacle, 15-Pin RS232	
X	X	X	X	-	-	X	-	X	Dehumidify Control	
-	-	-	X	-	-	-	-	-	High Output Evaporator Airflow	
-	-	-	-	-	-	-	-	-	Humidity System	
-	-	-	-	-	-	-	-	-	Power Line Communications, Standard (Thermo King Modem)	
-	-	-	-	-	-	-	-	-	Power Line Communications, RTE Modem	
X	X	X	-	-	-	-	-	-	Power Line Communications, Sabroe Control Modem	
-	-	-	-	-	-	-	-	-	Pressure Gauge, Discharge	
-	-	-	-	-	-	-	-	-	Pressure Gauge, Suction	
-	-	X	-	X	-	X	-	X	Recorder, Partlow	
-	X	-	-	-	X	-	-	-	Recorder, Saginomiya	
-	-	-	-	-	-	-	X	-	Redundant Supply and Return Sensors	
X	X	-	X	-	X	X	X	-	Remote Monitoring Plug (4-Pin)	
-	-	-	X	-	X	-	-	-	TRANSFRESH® Provision	
-	-	-	-	-	-	X	-	-	TRANSFRESH® Purge Port	
-	-	-	-	-	-	-	-	-	TRANSFRESH® System, Complete	
-	-	-	X	-	-	-	X	-	Thermistor Lead	
-	-	-	-	-	-	-	X	-	Water-Cooled Condenser-Receiver Tank with Moisture Indicating Sight Glass	

CRR Model Features (Continued)

CRR-40-151	<p style="text-align: center;">MODEL</p> <p style="text-align: center;">FEATURES X = Included</p>
X	460-380V/3Ph/60-50 Hz, 18.3 m (60 ft) Power Cable and Plug
-	Dual Voltage Feature: 15 kVA Autotransformer with 460-380V Power Receptacle and 230-190V/3Ph/60-50 Hz, 18.3 m (60 ft) Power Cable and Plug
X	Automatic Phase Selection Control
X	25 Amp Main Power Circuit Breaker
-	Slimline Frame
X	3DS Copeland Discus Compressor w/5.60 kW (7.5 Hp) Motor
-	3DF Copeland Discus Compressor w/5.60 kW (7.5 Hp) Motor
X	Compressor Liquid Injection System
X	Suction and Discharge Line Service Valves
X	Evaporator Pressure Regulator (KVQ Valve)
X	Refrigerant R-134a w/Polyol Ester Compressor Oil (TK P/N 203-433)
X	Receiver Tank with Moisture Indicating Sight Glass
X	µP-D Controller with Proportional-integral Differential (PID) Capacity Control
X	Controller Emergency Bypass Module
X	USDA Cold Treatment Temperature Recording
-	Three Evaporator Fans with 2-Speed Motors
X	Two Evaporator Fans with 2-Speed Motors
X	Fresh Air Exchange System
X	CO ₂ Sampling Port
X	One 1-Speed Condenser Fan Motor
X	Auxiliary Battery and Battery Charger
-	Bulb Mode Operation
-	Controlled Atmosphere System
X	Data Retrieval Receptacle, Standard (5-Pin Duetsch)
-	Data Retrieval Receptacle, 5-Pin Threaded Cannon
-	Data Retrieval Receptacle, 15-Pin RS232
X	Dehumidify Control
-	High Output Evaporator Airflow
-	Humidity System
-	Power Line Communications, Standard (Thermo King Modem)
-	Power Line Communications, RTE Modem
-	Power Line Communications, Sabroe Control Modem
-	Pressure Gauge, Discharge
-	Pressure Gauge, Suction
-	Recorder, Partlow
X	Recorder, Saginomiya
-	Redundant Supply and Return Sensors
-	Remote Monitoring Plug (4-Pin)
-	TRANSFRESH® Provision
-	TRANSFRESH® Purge Port
-	TRANSFRESH® System, Complete
-	Thermistor Lead
-	Water-Cooled Condenser-Receiver Tank with Moisture Indicating Sight Glass

Safety Precautions

General Practices

1. ALWAYS WEAR GOGGLES OR SAFETY GLASSES. Refrigerant liquid and battery acid can permanently damage the eyes (see First Aid under Refrigerant Oil).
2. Never close the compressor discharge valve with the unit in operation. Never operate the unit with the discharge valve closed.
3. Keep your hands, clothing and tools clear of the fans when the refrigeration unit is running. If it is necessary to run the refrigeration unit with covers removed, be very careful with tools or meters being used in the area.
4. Be sure the gauge manifold hoses are in good condition. Never let them come in contact with a fan motor blade or any hot surface.
5. Never apply heat to a sealed refrigeration system or container.
6. Fluorocarbon refrigerants, in the presence of an open flame or electrical arc, produce toxic gases that are severe respiratory irritants capable of causing death.
7. Be sure all mounting bolts are tight and are the correct length for their particular application.
8. Use extreme caution when drilling holes in the unit. The holes may weaken structural components. Holes drilled into electrical wiring can cause fire or explosion. Holes drilled into the refrigeration system may release refrigerant.
9. Use caution when working around exposed coil fins. The fins can cause painful lacerations.
10. Use caution when working with a refrigerant or refrigeration system in any closed or confined area with a limited air supply (for example, a trailer, container or in the hold of a ship). Refrigerant tends to displace air and can cause oxygen depletion, resulting in suffocation and possible death.
11. Use caution and follow the manufacturer's suggested practices when using ladders or scaffolds.

Refrigerant

When removing any refrigerant from a unit, use a recovery process that prevents or absolutely minimizes the refrigerant that can escape to the atmosphere. Although fluorocarbon refrigerants are classified as safe refrigerants when proper tools and procedures are used, certain precautions must be observed when handling them or servicing a unit in which they are used. When exposed to the atmosphere in the liquid state, fluorocarbon refrigerants evaporate rapidly, freezing anything they contact.

First Aid

In the event of frost bite, the objectives of First Aid are to protect the frozen area from further injury, to warm the affected area rapidly, and to maintain respiration.

- **EYES:** For contact with liquid, immediately flush eyes with large amounts of water and get prompt medical attention.
- **SKIN:** Flush area with large amounts of lukewarm water. Do not apply heat. Remove contaminated clothing and shoes. Wrap burns with dry, sterile, bulky dressing to protect from infection/injury. Get medical attention. Wash contaminated clothing before reuse.
- **INHALATION:** Move victim to fresh air and use CPR or mouth-to-mouth ventilation, if necessary. Stay with victim until arrival of emergency medical personnel.

Refrigerant Oil

Observe the following precautions when working with or around refrigerant oil:

- Do not allow refrigerant oil to contact your eyes.
- Do not allow prolonged or repeated contact with skin or clothing.
- To prevent irritation, you should wash thoroughly immediately after handling refrigerant oil. Rubber gloves are recommended when handling Polyol Ester based refrigerant oil.

First Aid

- **EYES:** Immediately flush eyes with large amounts of water for at least 15 minutes while holding the eyelids open. Get prompt medical attention.
- **SKIN:** Remove contaminated clothing. Wash thoroughly with soap and water. Get medical attention if irritation persists.
- **INHALATION:** Move victim to fresh air and restore breathing if necessary. Stay with victim until arrival of emergency personnel.
- **INGESTION:** Do not induce vomiting. Contact a local poison control center or physician immediately.

Electrical

High Voltage

When servicing or repairing a refrigeration unit, the possibility of serious or even fatal injury from electrical shock exists.

Extreme care must be used when working with a refrigeration unit that is connected to a source of operating power, even if the unit is not running. Lethal voltage potentials can exist at the unit power cord, inside the control box, inside any high voltage junction box, at the motors and within the wiring harnesses.

Precautions

1. Be certain the unit On/Off switch is turned OFF before connecting or disconnecting the unit power plug. Never attempt to stop the unit by disconnecting the power plug.
2. Be certain the unit power plug is clean and dry before connecting it to a power source.
3. Use tools with insulated handles that are in good condition. Never hold metal tools in your hand if exposed, energized conductors are within reach.

4. Do not make any rapid moves when working on high voltage circuits. If a tool or other object falls, do not attempt to grab it. People do not contact high voltage wires on purpose. It occurs from an unplanned movement.
5. Treat all wires and connections as high voltage until a meter and wiring diagram show otherwise.
6. Never work alone on high voltage circuits on the refrigeration unit. Another person should always be standing by in the event of an accident to shut off the refrigeration unit and to aid a victim.
7. Have electrically insulated gloves, cable cutters and safety glasses available in the immediate vicinity in the event of an accident.

First Aid

IMMEDIATE action must be initiated after a person has received an electrical shock. Obtain immediate medical assistance if available.

The source of shock must be immediately removed by either shutting down the power or removing the victim from the source. If it is not possible to shut off the power, the wire should be cut with either an insulated instrument (e.g., a wooden handled axe or cable cutters with heavy insulated handles) or by a rescuer wearing electrically insulated gloves and safety glasses. Whichever method is used, do not look at the wire while it is being cut. The ensuing flash can cause burns and blindness.

If the victim has to be removed from a live circuit, pull the victim off with a non-conductive material. Use the victim's coat, a rope, wood, or loop your belt around the victim's leg or arm and pull the victim off. **DO NOT TOUCH** the victim. You can receive a shock from current flowing through the victim's body.

After separating the victim from power source, check immediately for the presence of a pulse and respiration. If a pulse is not present, start CPR (Cardio Pulmonary Resuscitation) and call for emergency medical assistance. If a pulse is present, respiration may be restored by using mouth-to-mouth resuscitation, but call for emergency medical assistance.

Low Voltage

Control circuits are low voltage (24 Vac and 12 Vdc). This voltage potential is not considered dangerous, but the large amount of current available (over 30 amperes) can cause severe burns if shorted to ground.

Do not wear jewelry, watch or rings. These items can short out electrical circuits and cause severe burns to the wearer.

General Safety Precautions for Servicing Units (or Containers) Equipped with a Microprocessor Controller

Precautions must be taken to prevent electrostatic discharge when servicing the μ P-D microprocessor, output module and related components. If these precautionary measures are not followed, the risk of significant damage to the electronic components of the unit is possible.

The primary risk potential results from the failure to wear adequate electrostatic discharge preventive equipment when handling and servicing the microprocessor. The second cause results from electric welding on the unit and container chassis without taking precautionary steps.

Controller Repair

When servicing the microprocessor, it is necessary to ensure that electrostatic discharges are avoided. Potential differences considerably lower than those which produce a small spark from a finger to a door knob can severely damage or destroy solid-state integrated circuit components. The following procedures must be rigidly adhered to when servicing these units to avoid microprocessor damage or destruction.

1. Disconnect all power to the unit.
2. Avoid wearing clothing that generates static electricity (wool, nylon, polyester, etc.).
3. Do wear a static discharge wrist strap (TK P/N 204-622) with the lead end connected to the microprocessor's ground terminal. These straps are available at most electronic equipment distributors. DO NOT wear these straps with power applied to the unit.
4. Avoid contacting the electronic components on the circuit boards of the unit being serviced.
5. Leave the circuit boards in their static proof packing materials until ready for installation.
6. If a defective microprocessor is to be returned for repair, it should be returned in the same static protective packing materials from which the replacement component was removed.
7. After servicing the circuit board and any other circuits, the wiring should be checked for possible errors before restoring power.

Welding of Units or Containers

Whenever electric welding is to be performed on any portion of the refrigeration unit, container or container chassis with the refrigeration unit attached, it is necessary to ensure that welding currents are NOT allowed to flow through the electronic circuits of the unit. These procedures must be rigidly adhered to when servicing these units to avoid damage or destruction.

1. Disconnect all power to the refrigeration unit.
2. Disconnect all quick-disconnect wire harnesses from the back of the μ P-D controller. Also disconnect the wire harness from the Output module.
3. If the unit is equipped with a Remote Monitor Module (RMM) or Integrated Remote Monitor Unit (IRMU), disconnect all wire harnesses from the RMM/IRMU circuit board.
4. Switch all of the electrical circuit breakers in the control box to the OFF position.
5. Weld unit and/or container per normal welding procedures. Keep ground return electrode as close to the area to be welded as practical. This will reduce the likelihood of stray welding currents passing through any electrical or electronic circuits.
6. When the welding operation is completed, the unit power cables, wire harnesses and circuit breakers must be restored to their normal condition.

Unit Decals

Serial number decals, refrigerant type decals and warning decals appear on all Thermo King equipment. These decals provide information that may be needed to service or repair the unit. Service technicians should read and follow the instructions on all warning decals.

Serial Number Locations

Electric Motors: Nameplate attached to the motor housing.

Compressor: Nameplate on front of the compressor.

Unit: Nameplate on unit frame in power cord storage compartment.

µP-D Controller: Nameplate on back of controller.

<p>Warning Fans start automatically</p>	
--	---

<p>Warning Hot Components Compressor discharge may be hot</p>	
--	--

<p>Warning High voltage</p>	
--	---

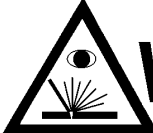
 <p>WARNING</p> <p>CONSULT MAINTENANCE MANUAL FOR PRECAUTIONS BEFORE WELDING ON CONTAINER OR REFRIGERATION UNIT.</p> <ol style="list-style-type: none"> 1. Disconnect all power to the refrigeration unit. 2. Disconnect all quick-disconnect wire harnesses from the back of the µP-D controller. Also disconnect the wire harness from the Output module. 3. If the unit is equipped with a Remote Monitor Module (RMM) or Integrated Remote Monitor Unit (IRMU), disconnect all wire harnesses from the RMM/IRMU circuit board. 4. Switch all of the electrical circuit breakers in the control box to the OFF position. 5. Weld unit and/or container per normal welding procedures. Keep ground return electrode as close to the area to be welded as practical. This will reduce the likelihood of stray welding currents passing through any electrical or electronic circuits. 6. When the welding operation is completed, the unit power cables, wiring harnesses and circuit breakers must be returned to their normal condition.

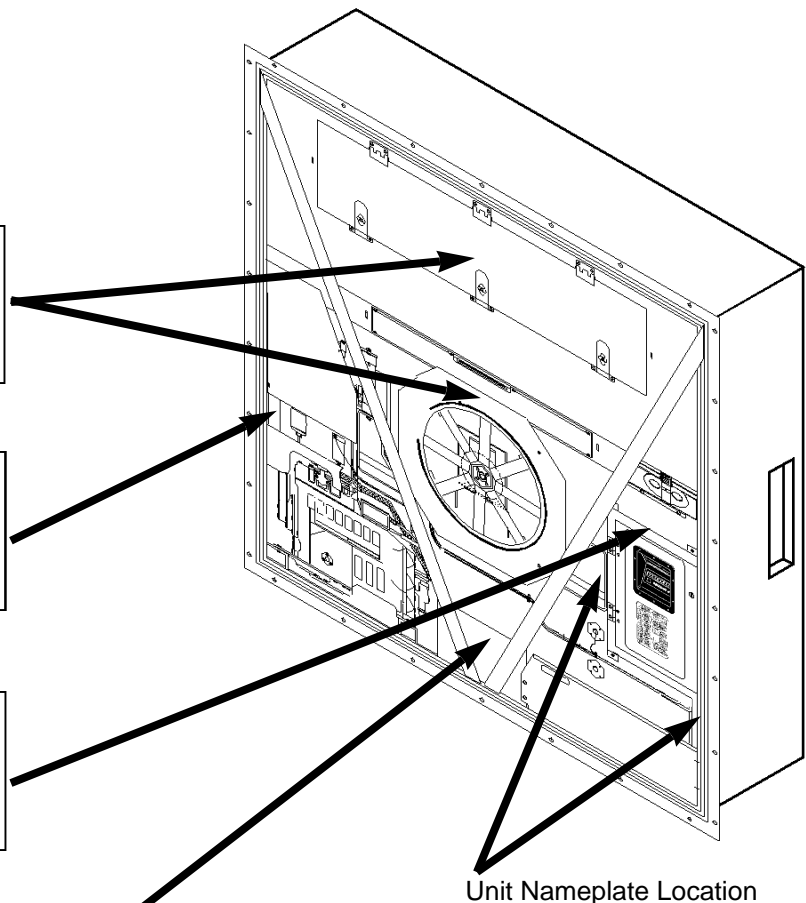

Service Guide

Pretrip	Every 1,000 Hours	Annual/ Yearly	Inspect/Service These Items
			Electrical
•			Perform a controller Full Pretrip Check.
	•	•	Perform a controller Extended Pretrip Check.
•	•	•	Visually inspect condenser fan and evaporator fan rotation.
•	•	•	Visually inspect electrical contacts for damage or loose connections.
•	•	•	Visually inspect wire harnesses for damaged wires or connections.
	•	•	Download the data logger and check data for correct logging.
		•	Check calibration of graded sensors.
			Refrigeration
•	•	•	Check refrigerant charge.
•	•	•	Check for proper suction pressure.
•	•	•	Check compressor oil level.
		•	Check compressor efficiency and pump down refrigeration system.
		•	Check liquid filter and dehydrator for a restriction or corrosion.
			Structural
•	•	•	Visually inspect unit for damaged, loose or broken parts.
•	•	•	Tighten unit, compressor and fan motor mounting bolts.
	•	•	Clean entire unit including condenser and evaporator coils and defrost drains.
			Humidify System (Option)
•			Check water level in water tank.
•	•	•	Check humidify system operation.
	•	•	Clean water supply filter on water tank.

System Net Cooling Capacity — Full Cool

CRR-40 Models with Three Evaporator Fans — Air Cooled Condensing*

Return air to evaporator coil inlet	460/230V, 3 Phase, 60 Hz Power				380/190V, 3 Phase, 50 Hz Power			
	Net Cooling Capacity			Power Consp	Net Cooling Capacity			Power Consp
	Watts	Kcal/hr	BTU/hr	kW @460V	Watts	Kcal/hr	BTU/hr	kW @460V
1.7 C (35 F)	11,450	9,850	39,100	10.5	9,540	8,205	32,570	8.7
-17.8 C (0 F)	5,605	4,820	19,125	6.6	4,670	4,015	15,930	5.5
-28.9 C (-20 F)	3,025	2,600	10,300	4.5	2,520	2,165	8,580	3.7

*System net cooling capacity with a 37.8 C (100 F) ambient air temperature and R-134a.

CRR-40 Models with Two Evaporator Fans — Air Cooled Condensing*

Return air to evaporator coil inlet	460/230V, 3 Phase, 60 Hz Power				380/190V, 3 Phase, 50 Hz Power			
	Net Cooling Capacity			Power Consp	Net Cooling Capacity			Power Consp
	Watts	Kcal/hr	BTU/hr	kW @460V	Watts	Kcal/hr	BTU/hr	kW @460V
1.7 C (35 F)	11,750	10,105	40,100	10.4	9,750	8,390	33,280	8.6
-17.8 C (0 F)	6,005	5,170	20,500	5.7	4,985	4,290	17,015	4.7
-28.9 C (-20 F)	3,105	2,670	10,600	4.3	2,580	2,220	8,800	3.6

*System net cooling capacity with a 37.8 C (100 F) ambient air temperature and R-134a.

CRR-20SL Models with Three Evaporator Fans — Air Cooled Condensing*

Return air to evaporator coil inlet	460/230V, 3 Phase, 60 Hz Power				380/190V, 3 Phase, 50 Hz Power			
	Net Cooling Capacity			Power Consp	Net Cooling Capacity			Power Consp
	Watts	Kcal/hr	BTU/hr	kW @460V	Watts	Kcal/hr	BTU/hr	kW @460V
1.7 C (35 F)	9,320	8,015	31,800	8.2	7,765	6,675	26,490	6.8
-17.8 C (0 F)	4,300	3,700	14,675	4.6	3,580	3,080	12,225	3.8
-25.0 C (-13 F)	3,000	2,580	10,240	4.2	2,500	2,150	8,530	3.5

*System net cooling capacity with a 37.8 C (100 F) ambient air temperature and R-134a.

System Net Cooling Capacity — Full Cool (Continues)

CRR-40 Models with Three Evaporator Fans — Water Cooled Condensing Option with 37.8 C (100 F) Water Temperature*

Return air to evaporator coil inlet	460/230V, 3 Phase, 60 Hz Power				380/190V, 3 Phase, 50 Hz Power			
	Net Cooling Capacity			Power Consp	Net Cooling Capacity			Power Consp
	Watts	Kcal/hr	BTU/hr	kW @460V	Watts	Kcal/hr	BTU/hr	kW @460V
1.7 C (35 F)	10,900	9,375	37,200	10.2	9,080	7,810	30,990	8.5
-17.8 C (0 F)	5,600	4,816	19,115	5.3	4,665	4,010	15,925	4.4

*System net cooling capacity with a 37.8 C (100 F) water temperature, 30 liter/min. (8 gal./min.) water flow and R-134a.

CRR-40 Models with Three Evaporator Fans — Water Cooled Condensing Option with 30 C (86 F) Water Temperature*

Return air to evaporator coil inlet	460/230V, 3 Phase, 60 Hz Power				380/190V, 3 Phase, 50 Hz Power			
	Net Cooling Capacity			Power Consp	Net Cooling Capacity			Power Consp
	Watts	Kcal/hr	BTU/hr	kW @460V	Watts	Kcal/hr	BTU/hr	kW @460V
1.7 C (35 F)	12,900	11,095	44,030	9.8	10,746	9,242	36,675	8.2
-17.8 C (0 F)	6,300	5,418	21,500	5.1	5,250	4,515	17,920	4.2

*System net cooling capacity with a 30 C (86 F) water temperature, 30 liter/min. (8 gal./min.) water flow and R-134a.

System Net Heating Capacity

CRR-20SL & CRR-40 Models*

Heater Type	460/230V, 3 Phase, 60 Hz Power			380/190V, 3 Phase, 50 Hz Power		
	Heating Capacity			Heating Capacity		
	Watts	Kcal/hr	BTU/hr	Watts	Kcal/hr	BTU/hr
CRR-20SL*	5,560	4,780	18,975	4,110	3,535	14,025
CRR-40*	5,880	5,060	20,070	4,900	4,215	16,720

*System net heating capacity for all models includes electric resistance rods and fan heat.

Evaporator Airflow

CRR-40 Models with Three Evaporator Fans

External Static Pressure (water column)	460/230V, 3 Phase, 60 Hz Power				380/190V, 3 Phase, 50 Hz Power			
	High Speed		Low Speed		High Speed		Low Speed	
	m ³ /hr	ft ³ /min	m ³ /hr	ft ³ /min	m ³ /hr	ft ³ /min	m ³ /hr	ft ³ /min
0 mm (0 in.)	6,470	3,810	3,116	1,835	5,400	3,180	2,600	1,530
10 mm (0.4 in.)	5,640	3,320	1,410	830	4,450	2,620	460	270
20 mm (0.8 in.)	4,770	2,810	—	—	3,395	2,000	—	—
30 mm (1.2 in.)	3,870	2,280	—	—	2,240	1,320	—	—
40 mm (1.6 in.)	2,885	1,700	—	—	935	550	—	—

High Performance Airflow Option for CRR-40 Models with Three Evaporator Fans

External Static Pressure (water column)	460/230V, 3 Phase, 60 Hz Power				380/190V, 3 Phase, 50 Hz Power			
	High Speed		Low Speed		High Speed		Low Speed	
	m ³ /hr	ft ³ /min	m ³ /hr	ft ³ /min	m ³ /hr	ft ³ /min	m ³ /hr	ft ³ /min
0 mm (0 in.)	7,200	4,240	3,650	2,148	6,000	3,531	2,870	1,689
10 mm (0.4 in.)	6,920	4,073	2,520	1,483	5,500	3,237	1,400	824
20 mm (0.8 in.)	6,500	3,828	—	—	5,000	2,943	—	—
30 mm (1.2 in.)	5,850	3,445	—	—	4,300	2,531	—	—
40 mm (1.6 in.)	5,200	3,060	—	—	3,500	2,061	—	—

CRR-40 Models with Two Evaporator Fans

External Static Pressure (water column)	460/230V, 3 Phase, 60 Hz Power				380/190V, 3 Phase, 50 Hz Power			
	High Speed		Low Speed		High Speed		Low Speed	
	m ³ /hr	ft ³ /min	m ³ /hr	ft ³ /min	m ³ /hr	ft ³ /min	m ³ /hr	ft ³ /min
0 mm (0 in.)	6,560	3,860	3,170	1,865	5,480	3,225	2,710	1,595
10 mm (0.4 in.)	5,820	3,425	1,770	1,040	4,530	2,665	930	545
20 mm (0.8 in.)	5,000	2,940	—	—	3,750	2,205	—	—
30 mm (1.2 in.)	4,430	2,610	—	—	2,930	1,725	—	—
40 mm (1.6 in.)	3,520	2,070	—	—	1,870	1,100	—	—

CRR-20SL Models with Three Evaporator Fans

External Static Pressure (water column)	460/230V, 3 Phase, 60 Hz Power				380/190V, 3 Phase, 50 Hz Power			
	High Speed		Low Speed		High Speed		Low Speed	
	m ³ /hr	ft ³ /min	m ³ /hr	ft ³ /min	m ³ /hr	ft ³ /min	m ³ /hr	ft ³ /min
0 mm (0 in.)	4,000	2,350	2,000	1,180	3,300	1,940	1,650	970
10 mm (0.4 in.)	3,500	2,060	1,450	850	2,600	1,530	900	530
20 mm (0.8 in.)	2,900	1,710	—	—	1,800	1,060	—	—
30 mm (1.2 in.)	2,200	1,300	—	—	1,100	650	—	—
40 mm (1.6 in.)	1,400	820	—	—	—	—	—	—

Refrigeration System

Compressor Model No.:	CRR-20SL CRR-40	3DFT-075X-TFD, Semi-hermetic with Copeland Discus® Valve 3DST-075X-TFD, Semi-hermetic with Copeland Discus® Valve
Refrigerant Charge:	Standard Receiver Tank Water-Cooled Condenser-Receiver Tank (Option)	4.9 Kg (10.8 lb) R-134a 5.45 Kg (12.0 lb) R-134a
Compressor Oil Capacity		1.77 liter (60 oz.)*
Compressor Oil Type		Polyol Ester Based Type (required), TK Part No. 203-433**
High Pressure Cutout Switch:		
All models (Except CRR-20SL-63):	Cutout Cutin	2410 +/- 70 kPa, 24.10 +/- 0.70 bar, 350 +/- 10 psig 1655 +/- 70 kPa, 16.55 +/- 0.70 bar, 240 +/- 10 psig
CRR-20SL-63:	Cutout Cutin	2240 +/- 70 kPa, 22.40 +/- 0.70 bar, 325 +/- 10 psig 1590 +/- 70 kPa, 15.90 +/- 0.70 bar, 230 +/- 10 psig
Condenser Fan Pressure Switch:	Open Close	1380 +/- 50 kPa, 13.80 +/- 0.50 bar, 200 +/- 7 psig 1100 +/- 50 kPa, 11.00 +/- 0.50 bar, 160 +/- 7 psig
Water Pressure Switch (Option):	Open Close	117 +/- 21 kPa, 1.17 +/- 0.20 bar, 17 +/- 3 psig 35 +/- 21 kPa, 0.35 +/- 0.20 bar, 5 +/- 3 psig
High Pressure Relief:		
Fusible Plug (Standard)	Relief Temp.	100 C (212 F)
Relief Valve (Option***):	Relief Pressure Reset	3447 +345/-104 kPa, 34.47 +3.45/-1.04 bar, 500 +50/-15 psig 2758 kPa, 27.58 bar, 400 psig
Liquid Injection Control:	Compressor Start Power Limit or Modulation Cool Compressor Discharge Temperature Control	Liquid injection valve opens for 5 minutes on each compressor start Liquid injection valve opens continuously during Power Limit and Modulation Cool modes Energizes (Opens) Liquid Injection Valve at 138 C (280 F) De-energizes (Closes) Liquid Injection Valve at 132 C (270 F) Compressor Shutdown (Auto Reset) at 148 C (298 F)
Liquid Injection Valve (Compressor):	Voltage Cold Resistance	24 Vac 5.6 ohms
Evaporator Pressure Regulator (KVQ Valve):	EPR Circuit Voltage EPR Circuit Resistance EPRTH (Thermistor) Circuit Resistance	24 Vdc 22 ohms 22,000 ohms at 20 C (68 F)

*When the compressor is removed from the unit, oil level should be noted or the oil removed from the compressor should be measured so that the same amount of oil can be maintained in the replacement compressor.

**DO NOT use or add standard synthetic or mineral oils to the refrigeration system. If Ester based oil becomes contaminated with moisture or with standard oils, dispose of properly — DO NOT USE!

***Included with Water-Cooled Condenser-Receiver Tank option.

Normal R-134a System Operating Pressures (3DS Copeland Reciprocating Compressor)*

Container Temp.	Operating Mode	Ambient Temp.	Suction Pressure	Discharge Pressure
21 C (70 F)	Cool	27 to 38 C, 80 to 100 F	110 to 140 kPa, 1.10 to 1.40 bar, 16 to 20 psig	1030 to 1930 kPa, 10.30 to 19.30 bar, 150 to 280 psig
		16 to 27 C, 60 to 80 F	103 to 131 kPa, 1.03 to 1.31 bar, 15 to 19 psig	1030 to 1450 kPa, 10.30 to 14.50 bar, 150 to 210 psig
2 C (35 F)	Cool	27 to 38 C, 80 to 100 F	76 to 103 kPa, 0.76 to 1.03 bar, 11 to 15 psig	1030 to 1725 kPa, 10.30 to 17.25 bar, 150 to 250 psig
		16 to 27 C, 60 to 80 F	55 to 83 kPa, 0.55 to 0.83 bar, 8 to 12 psig	1030 to 1450 kPa, 10.30 to 14.50 bar, 150 to 210 psig**
-18 C (0 F)	Cool	27 to 38 C, 80 to 100 F	-20 to 7 kPa, -0.20 to 0.07 bar, 6" Hg vacuum to 1 psig	1030 to 1450 kPa, 10.30 to 14.50 bar, 150 to 210 psig**
		16 to 27 C, 60 to 80 F	-27 to 0 kPa, -0.27 to 0 bar, 8" Hg vacuum to 0 psig	1030 to 1450 kPa, 10.30 to 14.50 bar, 150 to 210 psig**
-29 C (-20 F)	Cool	27 to 38 C, 80 to 100 F	-45 to -35 kPa, -0.45 to -0.35 bar, 14" to 11" Hg vacuum	1030 to 1450 kPa, 10.30 to 14.50 bar, 150 to 210 psig**
		16 to 27 C, 60 to 80 F	-50 to -35 kPa, -0.50 to -0.35 bar, 15" to 11" Hg vacuum	1030 to 1450 kPa, 10.30 to 14.50 bar, 150 to 210 psig**

*Suction and discharge pressures vary too greatly during Modulation Cool to use for evaluating or diagnosing refrigeration system performance. During the Modulation Cool mode, the suction pressure will vary between 140 and -35 kPa, 1.40 and -0.35 bar, 20 psig and 10" Hg vacuum depending upon the percent (%) modulation.

**Discharge pressure is determined by condenser fan cycling.

Thermoguard® μP-D Microprocessor

Temperature Controller:	Type	Thermoguard® μP-D microprocessor with digital thermostat, thermometer and fault indicator monitor
	Setpoint Range	-30.0 to +30.0 C (-22.0 to +86.0 F)
	Digital Temperature Display	-40.0 to +130.0 C (-40.0 to +266.0 F)
Output Module		Energizes and de-energizes unit contactors and solenoids in response to serial communications commands from the μP-D controller. Indicator LEDs on the Output Module indicate an output is energized. RXD and TXD indicator LEDs alternately flash to show the communications connection is good. If one or both of the RXD and TXD LEDs do NOT flash, the communications connection is open or defective.
Thermo Bus PC Board		Transfers the serial communications commands from the μP-D controller to the Output Module.
Power Module PC Board		Supplies low voltage control power to the μP-D controller, Output Module and KVQ valve. Fuses provide current overload protection to unit control circuits.
Controller Software (Original Equipment):	Version	See controller identification decal
	Unit Configuration (CFG U)	See controller identification decal
	Customer Configuration (CFG C)	See controller identification decal
Defrost Initiation	Evaporator Coil Sensor	Coil must be below 10 C (50 F) to initiate defrost by demand, timer or manual switch
	Demand Defrost	Demand defrost function initiates defrost when the return air and refrigeration systems conditions indicate the presence of frost or ice
	Defrost Timer: Chill Mode*	<ul style="list-style-type: none"> • Default: Every 3 hours until two timed defrosts occur without a demand defrost in between. Then defrost interval increases 1 hour every other timed defrost interval. Maximum time interval is 8 hours • Customer Configuration C5: Standard default times but maximum time interval is 6 hours on chill loads. • Customer Configuration C6: 2 hour initial defrost, then maximum time interval is 6 hours on chill loads.
	Defrost Timer: Frozen Mode*	<ul style="list-style-type: none"> • Default: Every 6 hours until two timed defrosts occur without a demand defrost in between. Then defrost interval increases 2 hours each timed defrost interval. Maximum time interval is 24 hours • Customer Configuration C5: Standard default times but maximum time interval is 12 hours on frozen loads. • Customer Configuration C6: 2 hour initial defrost, then maximum time interval is 6 hours on frozen loads.

*Timed defrost intervals reset to initial value after a manual defrost, after the unit has been OFF for 48 hours and after a setpoint change from Chill to Frozen mode or Frozen to Chill mode.

Thermoguard® µP-D Microprocessor (Continued)

Defrost Termination: Evaporator Coil Sensor*	Chill mode: Terminates defrost when coil sensor temperature rises to 30 C (86.0 F) Frozen mode: Terminates defrost when coil sensor temperature rises to 18 C (64.4 F)
Interval Timer**	Terminates defrost 90 minutes after initiation if coil sensor has not terminated defrost
Time/Temperature Function	If the evaporator coil sensor exceeds 8 C (46 F) for 10 minutes, the controller terminates defrost (Frozen Mode Only)
Power Off	Turning unit On/Off switch OFF terminates defrost
Evaporator Over Temperature Protection	Operates only when unit is in Heat or Defrost modes: Opens heater contactor at 38 C (100 F). Opens phase select contactor to shut down all unit operation and initiate an alarm at 50 C (122 F)
Bulb Mode (Option)***: Defrost Termination Temperature (BDFTT) Setting	4 to 30 C (40 to 86 F)
Evaporator Fan Speed Settings	High Speed only; Low Speed only; or Cycle (fans will cycle between low and high speeds every 60 minutes)
Economy Mode (Standard Feature): Description	Reduces power consumption by reducing evaporator fan operation
Set to ON for Fresh Loads	Evaporator fans operate on low speed whenever the container temperature is In-range
Set to ON for Frozen Loads	Evaporator fans stop during Null mode. Controller operates fans for 5 minutes every 45 minutes to circulate container air
Turn Mode ON and OFF	Set from ECON screen of the Program menu of the controller
ECMIN Temperature	2.0 C (3.6 F) default setting; Adjustable from 0 to 10 C (0 to 18 F) in Menu Guard
ECMAX Temperature	1.0 C (1.8 F) default setting; Adjustable from 0 to 10 C (0 to 18 F) in Menu Guard
Power Reduction Mode (Standard Feature): Power Reduction (PWRED) Settings	0 = OFF; 1 = 10% Power Reduction; 2 = 20% Power Reduction; 3 = 30% Power Reduction
Pulp Mode (Option)****: Control Settings	OFF or ON (Controller records Pulp Sensor temperature)
USDA Mode (Standard Feature): Turn Mode ON and OFF Operation	Set from USDA screen of the Program menu of the controller Controller automatically detects sensors to initiate data logging. However, USDA sensors must be ice bath calibrated to accurately record temperature

*If the evaporator coil sensor fails, the controller terminates defrost when the return air (top) sensor rises to 18 C (64.4 F).

**If both the evaporator coil and return air (top) sensors fail, the interval timer terminates defrost 60 minutes after initiation.

***Unit must be equipped with dehumidify system.

****Sensor must be installed and calibrated.

Electrical System

Compressor Motor:	Type	460/380V, 60/50 Hz, 3 Phase
	Kilowatts (60 Hz)	5.60 kW
	Horsepower (60 Hz)	7.5 hp
	RPM (60 Hz)	1750 rpm
	Full Load Amps	15.5 amps — 460V; 15.5 amps — 380V
	Locked Rotor Amps	83 amps — 460V; 82 to 91 amps — 380V
Condenser Fan Motor*:		
Red Color Finish:	Type	460/380V, 60/50 Hz, 3 Phase
	Kilowatts (60 Hz)	0.56 kW
	Horsepower (60 Hz)	0.75 hp
	RPM (60 Hz)	1140 rpm
	Full Load Amps (60 Hz)	1.3 amps — 460V
Black Color Finish:	Type	460/380V, 60/50 Hz, 3 Phase
	Kilowatts (60 Hz)	0.37 kW
	Horsepower (60 Hz)	0.50 hp
	RPM (60 Hz)	1145 rpm
	Full Load Amps	0.9 amps — 460V; 1.0 amps — 380V
	Locked Rotor Amps	4.0 amps — 460V; 4.4 amps — 380V
Evaporator Fan Motors*:		
Red Color Finish:	Type	460/380V, 60/50 Hz, 3 Phase
	Number	3 or 2
	Kilowatts (60 Hz) (Each)	0.75 kW
	Horsepower (60 Hz) (Each)	1.0 hp
	RPM (60 Hz) (Each)	3450 rpm, High Speed 1725 rpm, Low Speed
	Full Load Amps (60 Hz) (Each)	1.2 amps — 460V, High Speed 0.5 amps — 460V, Low Speed
Black Color Finish:	Type	460/380V, 60/50 Hz, 3 Phase
	Number	3 or 2
	Kilowatts (60 Hz)	0.75 kW
	Horsepower (60 Hz)	1.0 hp
	RPM (60 Hz) (Each)	3450 rpm, High Speed 1725 rpm, Low Speed
	Full Load Amps (60 Hz) (Each)	1.2 amps — 460V, High Speed 0.5 amps — 460V, Low Speed
	Locked Rotor Amps (60 Hz)	10.3 amps — 460V
Electric Resistance Heater Rods:	Type	460/380V, 60/50 Hz, 3 Phase
	Number	6
	Watts (60 Hz) (Each)	680 Watts
	Current Draw (Amps)	5 amps nominal (total) across each phase at the heater contactor
Control Circuit Voltage		24 Vac
Auxiliary Battery (Option)		12 Vdc, 7 or 12 amp hour

*Use the motor color to identify the motor used in units built between 3/1/99 and 7/31/99.

Dehumidify and Humidify Systems (Options)

Dehumidify System (Option): Turn Mode ON and OFF Control Range (HUMSP) Setting	Set from HUMID screen of the Program menu of the controller 50% to 100% Relative Humidity
Humidify System (Option): Turn Mode ON and OFF Operating Temperature Range Control Range (HUMSP) Setting Air Compressor Output Humidity Tank Heater:	Set from HUMID screen of the Program menu of the controller 0 to 60 C (32 to 140 F) 50% to 100% Relative Humidity 2.5 m ³ /hr @ 0 kPa (1.5 CFM @ 0 psig) 240-600 Vac 55 to 70 Watts at -17.8 C (0 F) Water Temperature
Humidity Sensor: Accuracy: Output Range:	+/- 1.5% between 55% and 75% Relative Humidity +/- 3.0% between 75% and 95% Relative Humidity 4 to 20 milliamps 1% Relative Humidity = 0.2 milliamp

Physical Specifications

Fresh Air Exchange Venting System (Adjustable): CRR-20SL CRR-40 & CRR-40SL	0 to 160 m ³ /hr (0 to 94 ft ³ /min.) @ 60 Hz 0 to 134 m ³ /hr (0 to 79 ft ³ /min.) @ 50 Hz 0 to 285 m ³ /hr (0 to 168 ft ³ /min.) @ 60 Hz 0 to 236 m ³ /hr (0 to 139 ft ³ /min.) @ 50 Hz
Evaporator Fan Blade Specifications: CRR-20SL with Three Evaporator Fans: Diameter Pitch CRR-40SL with Three Evaporator Fans: Diameter Pitch CRR-40 with Three Evaporator Fans: Diameter Pitch CRR-40 High Performance Airflow: Diameter Pitch CRR-40 with Two Evaporator Fans: Diameter Pitch	280 mm (11.02 in.) 19° 312 mm (12.25 in.) 25° 355 mm (14.0 in.) 19° 355 mm (14.0 in.) (Three Evaporator Fans) 22° 355 mm (14.0 in.) 25°
Recording Thermometer Options: Type Type	31-Day Saginomiya SKM, battery driven recording chart 31-Day Partlow, spring wound recording thermometer
Weight (net): CRR-20SL Base Unit CRR-40 & CRR-40SL Base Unit Dual Voltage Option Power Line Communications Option Recorder (Partlow or Saginomiya) Option TRANSFRESH® Option Water-cooled Condenser-Receiver Option	498 Kg (1097 lb) 522 Kg (1150 lb) 45 Kg (99 lb) 3.6 Kg (8 lb) 5.9 Kg (13 lb) 13 Kg (28 lb) 13.6 Kg (30 lb)

Physical Specifications (Continued)

Unit Dimensions:	A = Flange Width	2025.5 mm (79.74 in.)
	B = Gasket Width	1935 mm (76.18 in.)
	C = Unit Width	1894 mm (74.57 in.)
	D = Flange Height	2235.2 mm (88.00 in.)
	E = Gasket Height	2140 mm (84.25 in.)
	F = Unit Height	2094 mm (82.44 in.)
	G = Maximum Protrusion	37 mm (1.46 in.) from back of flange
	H = Unit Depth	CRR-20SL: 335.0 mm (13.18 in.) from back of flange CRR-40SL: 378.0 mm (14.88 in.) from back of flange CRR-40: 420.0 mm (16.54 in.) from back of flange
	I = Gasket Depth	72 mm (2.83 in.) from back of flange

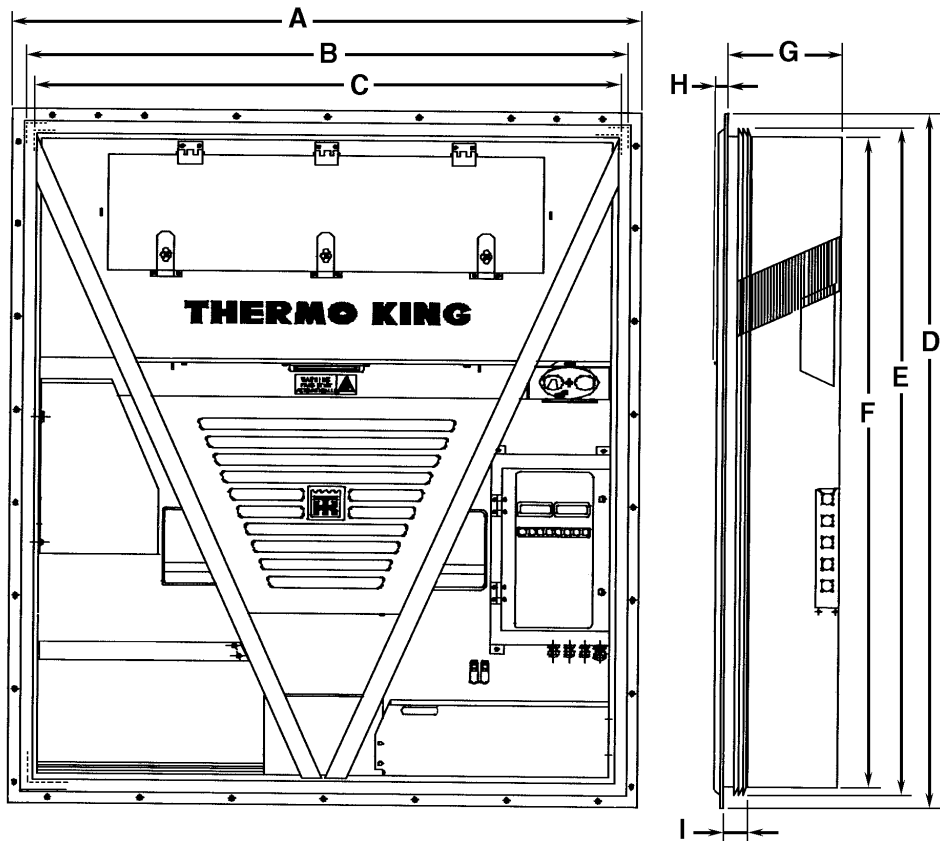

Compressor Torque Chart — 3D Copeland Compressor Standard Bolt Torque

Bolt Usage		N.m	In.-lb.
Bottom Plate:	Grade 5	45.2	400
	Grade 8	59.3	525
Housing Cover		45.2	400
Oil Pump to Housing Cover		33.9	300
Bearing Cover to housing Cover		33.9	300
Stator Cover:	Grade 5	45.2	400
	Grade 8	59.3	525
Cylinder head		59.3	525
Oil Screen Cover		31.1	275
Crankcase Heater Plug		45.2	400
Discharge and Suction Valve:	18 (5/16 in.)	25.4	225
	13 (1/2 in.)	56.5	500
Pipe Plug:	6.35 mm (0.25 in.)	33.9	300
	3.175 mm (0.125 in.)	22.6	200
Oil Sight Glass:	Grade 5	4.5	40
	Grade 8	8.5	75
Terminal Plate		33.9	300
Nut on Top of Terminal Plate		5.1	45
Nut on Top of Jumper Bar		9.0	80

Metric Hardware Torque Charts

Bolt Type and Class*	Bolt Size			
	M6	M8	M10	M12
	N.m (Ft.-lb.)	N.m (Ft.-lb.)	N.m (Ft.-lb.)	N.m (Ft.-lb.)
HH – CL 5.8	6-9 (4-7)	12-16 (9-12)	27-34 (20-25)	48-61 (35-40)
HH – CL 8.8	10-13 (7-10)	20-27 (15-20)	41-47 (30-35)	75-88 (55-65)
HH – CL 10.9	14-17 (10-13)	27-34 (20-25)	54-68 (40-50)	102-122 (75-90)
HH – CL 12.9	17-21 (12-16)	41-47 (30-35)	68-81 (50-60)	122-149 (90-110)
HH – SS (2)	10-13 (7-10)	20-27 (15-20)	41-47 (30-35)	75-88 (55-65)

Bolt Type and Class*	Bolt Size			
	M14	M16	M18	M22
	N.m (Ft.-lb.)	N.m (Ft.-lb.)	N.m (Ft.-lb.)	N.m (Ft.-lb.)
HH – CL 5.8	75-88 (55-65)	115-135 (85-100)	177-216 (130-160)	339-406 (250-300)
HH – CL 8.8	115-135 (85-100)	177-216 (130-160)	271-339 (200-250)	475-610 (350-450)
HH – CL 10.9	136-176 (100-130)	224-298 (180-220)	393-474 (290-350)	678- 813 (500-600)
HH – CL 12.9	177-216 (130-160)	285-352 (210-260)	448-542 (330-400)	881-1016 (650-750)
HH – SS (2)	115-135 (85-100)	177-216 (130-160)	271-339 (200-250)	475-610 (350-450)

*HH = Hex Head, CL = Class.

General Description

Model CRR-20SL and CRR-40 units are all-electric, single-piece, refrigeration units with bottom air supply. Each unit is designed to cool and heat containers for shipboard or overland transit. Each unit mounts in the front wall of the container. CRR-20SL units feature a slimline frame. Fork lift pockets are provided for installation and removal of the unit.

The frame and bulkhead panels are constructed of aluminum and are treated to resist corrosion. A hinged, removable evaporator compartment door provides easy service access. All operating components except the evaporator coil can be replaced from the front of the unit.

Each unit is equipped with an 18.3 m (60 ft) power cable for operation on 460-380V/3 Ph/60-50 Hz power. For operation on 460-380V/3 Ph/60-50 Hz power, plug the 460-380V power cable into the proper power supply.

Each unit is equipped with 460-380V/3 Ph/60-50 Hz electric motors. An automatic phase correction system provides the proper electrical phase sequence for compressor, condenser fan and evaporator fan motor operation. The unit power cable is stored below the control box in the condenser section.

Unit features include a semi-hermetic reciprocating compressor with a liquid injection system; 2-speed evaporator fans; a fresh air exchange system; and a Thermoguard® μ P-D micro-processor controller with indicator LEDs. The μ P-D controller controls, monitors and records unit operation using supply air, return air, evaporator coil, condenser coil, ambient and compressor discharge temperature sensors. For additional unit feature information, see "CRR Model Features" on pages vi through viii of the Introduction.

Semi-hermetic Reciprocating Compressor with Liquid Injection Cooling System

The refrigeration unit includes a semi-hermetic reciprocating compressor with forced feed lubrication system, ambient compensated internal overload and high temperature protectors, and a refrigerant injection system.

Dual Speed Evaporator Fans

CRR models are equipped with either 2 or 3 evaporator fans. All models feature 2-speed motors. The evaporator fans operate continuously to circulate air inside the container. The fans operate on high speed for perishable cargo at return air temperatures of -9.9 C (14.1 F) and above. At return air temperatures of -10 C (14 F) and below, the evaporator fans operate on low speed for frozen cargo.

NOTE: If Economy Mode is ON:

- **Fresh Loads: Evaporator fans operate on low speed when container temperature is in-range.**
- **Frozen Loads: Evaporator fans stop during the Null mode; controller operates fans on low speed for 5 minutes every 45 minutes.**

Fresh Air Exchange System

The fresh air exchange system removes harmful gases from containers carrying sensitive perishable commodities. The fresh air vent is located above the control box. The fresh air vent is adjustable to accommodate a variety of cargo and chilled load operating conditions. The fresh air vent should be tightly closed when carrying frozen cargo.

Thermoguard® μ P-D Controller

The μ P-D controller incorporates refrigeration system component control, thermostat, digital thermometer, fault indicator and data recording capabilities into one self-contained package. The μ P-D controller provides accurate air temperature control of perishable and frozen cargo.

The controller features a weather tight, corrosion resistance enclosure. Two large alpha-numeric digital displays are backlit and tilted for easy viewing. Ten control keys provide quick access to unit operating information and easy completion of setpoint, manual defrost, pretrip and start-of-trip programming.

A μ P-D output module is used by the controller to energize and de-energize various contactors and solenoids. An

LED indicator is included in each output circuit to show when the output is energized. The μ P-D output module is located inside the control box.

Indicator Lights

Indicator lights on the μ P-D controller signal Cool, Modulation, Null, Heat, In-range, Defrost, Supply Air Temperature, Return Air Temperature, Power Limit and Alarm.

USDA Cold Treatment Temperature Recording

The μ P-D controller includes provisions for the use of three or four USDA sensors. These sensors allow temperatures in various areas of the load to be monitored and recorded for United States Department of Agriculture use in monitoring Cold Treatment shipments. The controller software must be configured for USDA temperature recording and set to "USDA ON" (through the Program submenu).

Auxiliary Battery and Battery Charger Option

An optional 12 Vdc, 7 or 12 amp hour battery provides power for controller operation and datalogging when unit 460-380 Vac supply power is disconnected. A regulated battery charger automatically maintains the battery charge when 460-380 Vac power is connected to the unit.

Dehumidification Control System Option

An optional dehumidification system lowers the relative humidity in the container to the humidity setpoint. The control range setpoint is adjustable between 50% and 100%.

Humidification Control System Option

An optional humidification system increases the relative humidity in the container to the humidity setpoint. The control range setpoint is adjustable between 50% and 100%.

Controlled Atmosphere System Option

An optional controlled atmosphere system includes two charging ports and a pressure relief valve to provide a modified atmosphere within the container. By controlling the container temperature and atmosphere, the respiration rate of fruit and vegetables can be lowered. This allows the product quality to be maintained for longer periods of time.

Dual Voltage Option

A dual voltage system includes a 15 KVA auto transformer and an 18.3 m (60 ft) power cable for operation on 230-190V/3 Ph/60-50 Hz power. The power cable is stored below the control box in the condenser section.

The 15 KVA auto transformer steps 230/190V power up to 460/380V. The auto transformer includes a 460-380V/3 Ph/60-50 Hz power receptacle.

For operation on 230/190V power, plug the 460-380V unit power cable into the receptacle on the auto transformer. Then plug the 230/190V power cable into a 230-190V power supply.

Remote Monitoring Receptacle (4-Pin) Option

An optional 4-pin remote monitor connector provides 24 Vac signals for bridge lights that monitor Cool (Compressor On), Defrost and In-range conditions.

Recording Thermometer Options

Several models of temperature recorders are available for mounting on the unit. Each temperature recorder is designed to withstand widely varying environments including low and high ambient temperatures, salt water, humidity, fungus, industrial pollutants, dynamic loading, rain, sand and dust.

- The 31-day Saginomiya Recorder is electric motor driven by a dry cell type battery with a 1 year life expectancy.
- The 31-day Partlow Recorder is mechanically driven by a spring mechanism.

Power Line Communications Option

Several models of remote monitoring modems are available to provide remote monitoring via the power cable. High speed transmission reads all controller information.

- Thermo King ISO narrow band power line remote monitoring modem is installed in a self-enclosed box bolted above the compressor compartment.
- Sabroe Controls ISO wide band power line remote monitoring modem is installed in the electrical control box.
- RTE ISO narrow band power line remote monitoring modem is installed in the electrical control box.

Pressure Gauge Options

A high pressure gauge is available to indicate condenser (high side) pressure. A low pressure gauge is available to indicate compressor suction (low side) pressure.

Redundant Sensors

Redundant return and supply air sensors are installed using the USDA1 and USDA2 sensor ports.

- USDA1 = Return Air Sensor
- USDA2 = Supply Air Sensor

TRANSFRESH® Atmosphere Control System Options

Several TRANSFRESH options are available to meet individual customer needs. The TRANSFRESH system provides a controlled atmosphere within the container. By controlling the container temperature and atmosphere, the respiration rate of fruit and vegetables can be lowered. This allows the product quality to be maintained for longer periods of time.

- Provisions for the future installation and use of a TRANSFRESH atmosphere control system can be incorporated in the unit. TRANSFRESH compatible A2 (power/defrost) and A3 (communications) cables are factory installed.
- TRANSFRESH system components are installed for use of a TRANSFRESH atmosphere control system. In addition to A2 and A3 cables, the security frame, security enclosure with insulation block, air hose and scrubber cable are factory installed.
- TRANSFRESH Supplied Purge Port: A TRANSFRESH supplied single purge port is factory installed. Port includes a removable plug for charging the container with a modified atmosphere.

Water-Cooled Condenser-Receiver Option

An optional water-cooled condenser-receiver tank provides the unit with above deck and below deck operating capabilities. A water pressure switch is provided on the water inlet line connection. When water pressure is supplied to unit, the normally closed water pressure switch opens. This causes the controller to stop condenser fan operation.

Operating Modes

NOTE: See μ P-D Controller chapter for complete sequence of operation.

When the unit is started, two backlit LED displays on the microprocessor illuminate. A sequence start of the required loads occurs during initial start-up of the microprocessor and when a control mode shift requires the compressor to start.

The digital displays indicate the setpoint temperature and the controlling air sensor temperature as the microprocessor relays and unit loads energize. The controlling sensor is determined by the setpoint temperature:

Setpoint	Controlling Sensor
-9.9 C (14.1 F) and above	Supply Air Temperature
-10 C (14 F) and below	Return Air Temperature

The μ P-D controller uses a proportional-integral derivative (PID) algorithm to provide accurate temperature control in direct response to load demand. Therefore it is difficult to predict which operating mode the unit should be in by comparing the setpoint to the return or supply air temperature. The unit operates in either the Chill (Fresh) or Frozen mode. Chill to Frozen mode transition point is -10 C (14 F).

NOTE: If the compressor has been OFF for more than 8 hours, or the the unit has been on heat or defrost; the microprocessor performs a compressor soft start.

Chill Loads: Controller Setpoint at -9.9 C (14.1 F) or Above

Temperature control by the controller is based on the supply air sensor temperature, the setpoint, the modulation temperature range and the pull-down rate. The evaporator fans operate in high speed.

- Cool
- Modulation Cool
- Null (compressor pumps down low side for 60 seconds and stops, evaporator fans operate, if condenser fan is ON, it will operate for 30 seconds and then stop)
- Heat (resistance heaters on, evaporator fans operate)
- Defrost (resistance heaters on, evaporator fans stop)

NOTE: If the Economy Mode is set to ON in the Program menu of the μ P-D controller, the evaporator fans operate on low speed at setpoints of -9.9 C (14.1 F) and above whenever the container temperature is In-range.

Frozen Loads: Controller Setpoint at -10 C (14 F) or Below

Temperature control by the controller is based on the return air sensor temperature. The evaporator fans operate on low speed (when container return air sensor temperature drops below -10 C [14 F]).

- Cool
- Null (compressor pumps down low side for 30 seconds and stops, evaporator fans operate, if condenser fan is ON, it will operate for 30 seconds and then stop)
- Defrost (resistance heaters on, evaporator fans stop)

NOTE: If the Economy Mode is set to ON in the Program menu of the μ P-D controller, the unit continues in Cool until the return air temperature decreases to the ECMIN temperature. The default ECMIN setting is 2.0 C (3.6 F) below setpoint. After the unit shifts to Null, the evaporator fans stop. During Economy Mode operation, a Null state timer automatically starts and operates the evaporator fans on low speed for 5 minutes every 45 minutes. The unit remains in Null until the return air temperature increases to ECMAX temperature at the expiration of a 45 minute Null state time sequence. The default ECMAX setting is 1.0 C (1.8 F) above setpoint.

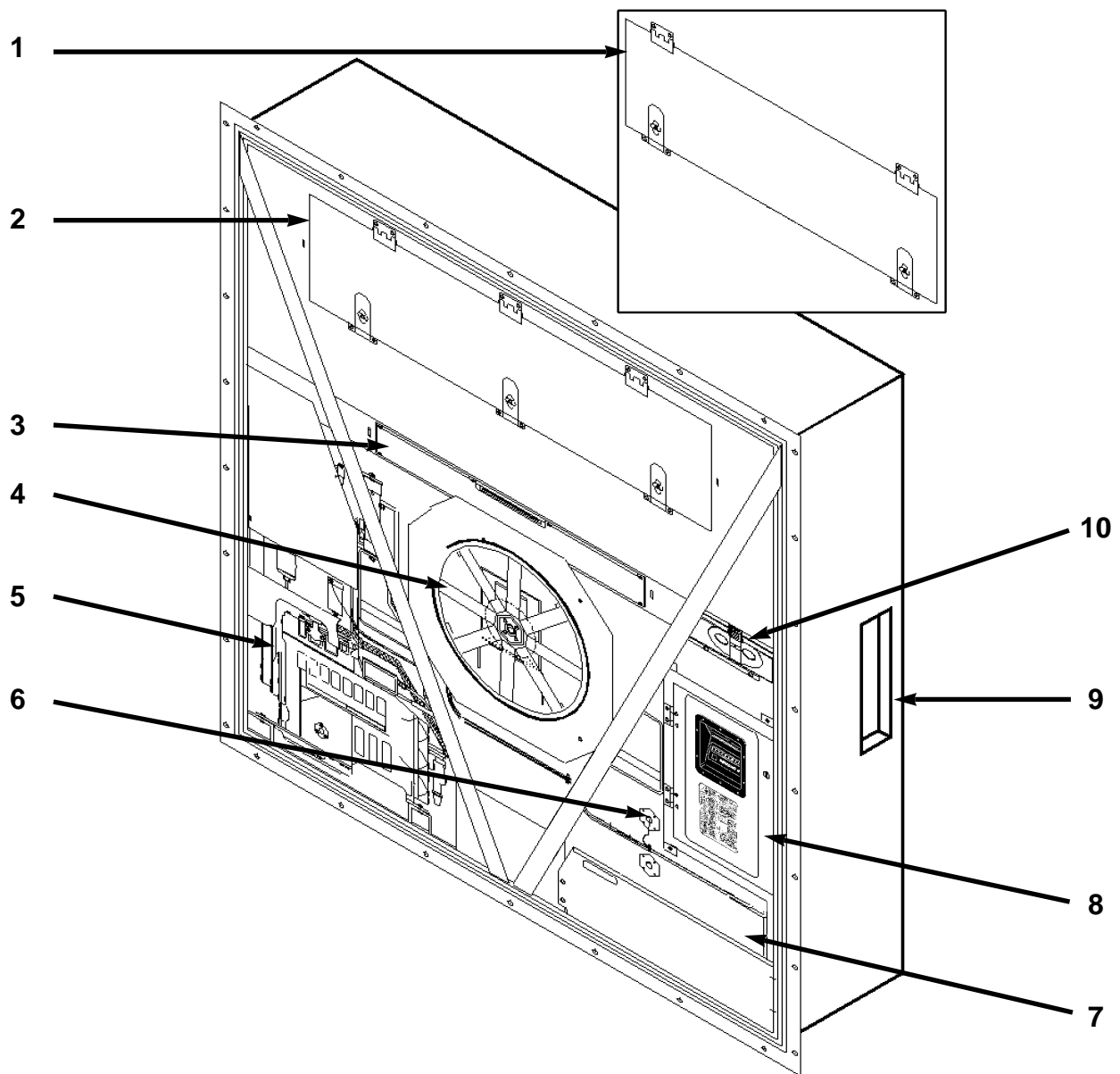

Typical Unit Front View

1. Evaporator Access Door, 1018 mm (40.08 in.) Wide with Two Latches — Models with Two Evaporator Fans
2. Evaporator Access Door, 1399 mm (55.04 in.) Wide with Three Latches — Models with Three Evaporator Fans
3. Heater Access Panel Location
4. Condenser Fan
5. Compressor Compartment
6. Supply Air Sensor Probe Holder
7. Power Cord Storage Compartment
8. Control Box
9. USDA Receptacle Panel (Access from Inside Container)
10. Fresh Air Exchange Vent

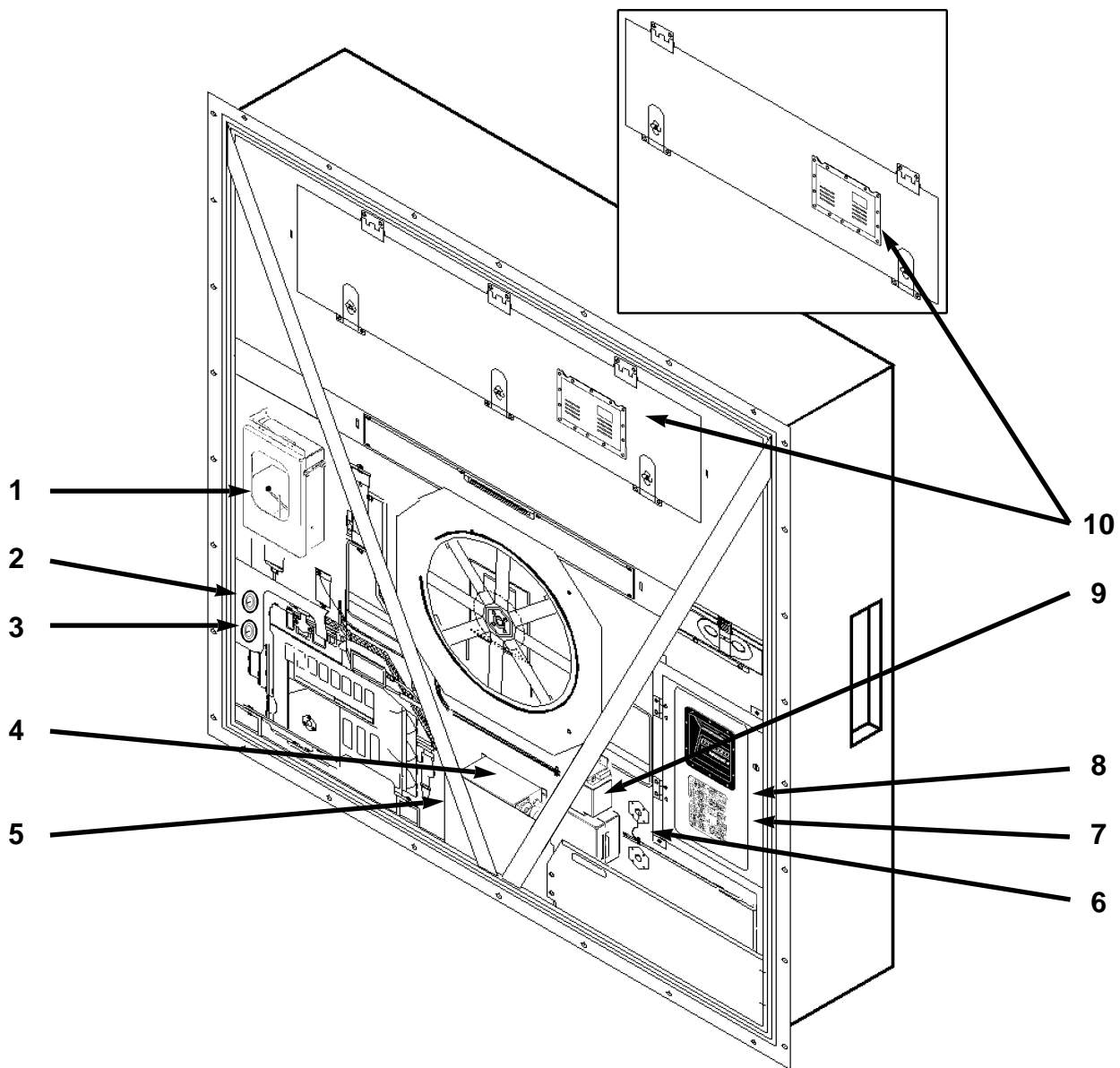

Unit Options Front View

1. Recording Thermometer Option
2. Suction Pressure Gauge Option
3. Discharge Pressure Gauge Option
4. Dual Voltage Option
5. TRANSFRESH Download Receptacle, Option
6. Remote Monitor Plug Option (4-Pin Connector on Side of Control Box)
7. Thermistor Lead Option (Lead inside Control Box)
8. Remote Monitor Modem for Power Line Communications (Sabroe Control modem inside Control Box)
9. Auxiliary Battery and Batter Charger Option
10. TRANSFRESH Option, Complete

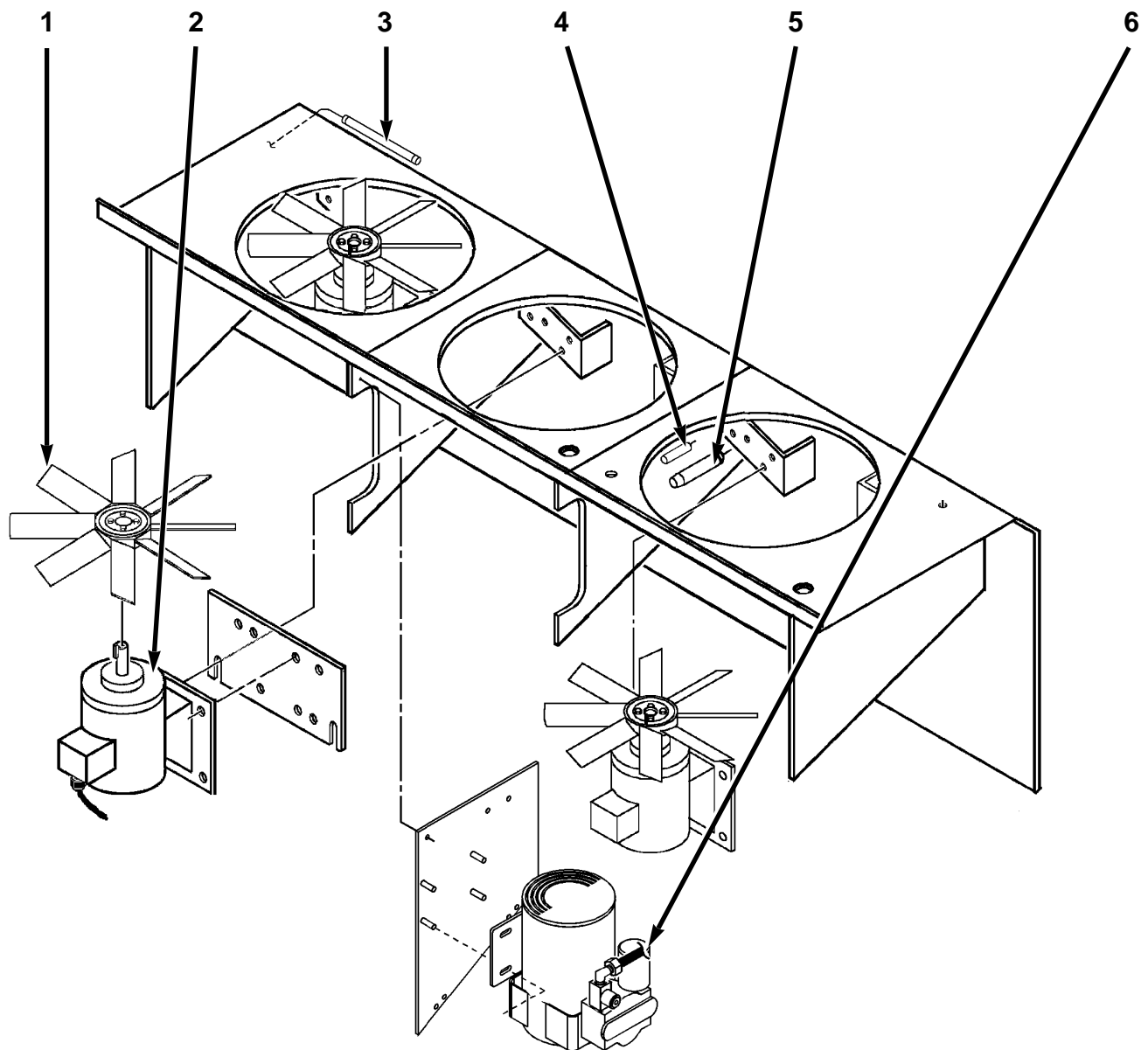
**Evaporator Section for Models with Three Evaporator Fans — Front View**

1. Evaporator Fan Blade (see "Physical Specifications" on page 1-9 for description)
2. Evaporator Fan Motor
3. Return Air Sensing Bulb for Recording Thermometer (Option)
4. Return Air Sensor
5. Humidity Sensor (Option)
6. Humidity System Compressor (Option), see page 2-16

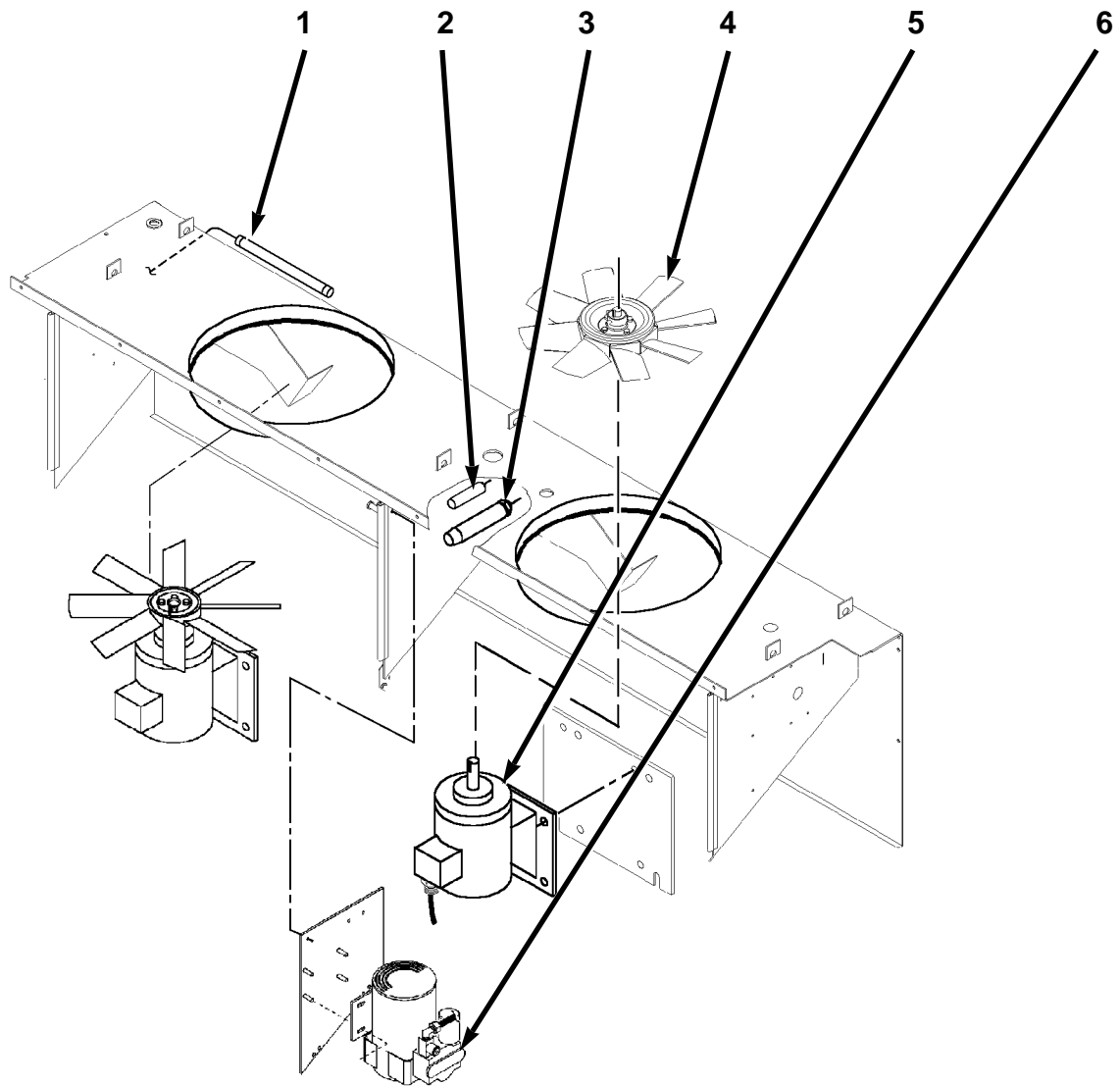
**Evaporator Section for Models with Two Evaporator Fans — Front View**

1. Return Air Sensing Bulb for Recording Thermometer (Option)
2. Return Air Sensor
3. Humidity Sensor (Option)
4. Evaporator Fan Blade (see "Physical Specifications" on page 1-9 for description)
5. Evaporator Fan Motor
6. Humidity System Compressor (Option), see page 2-16

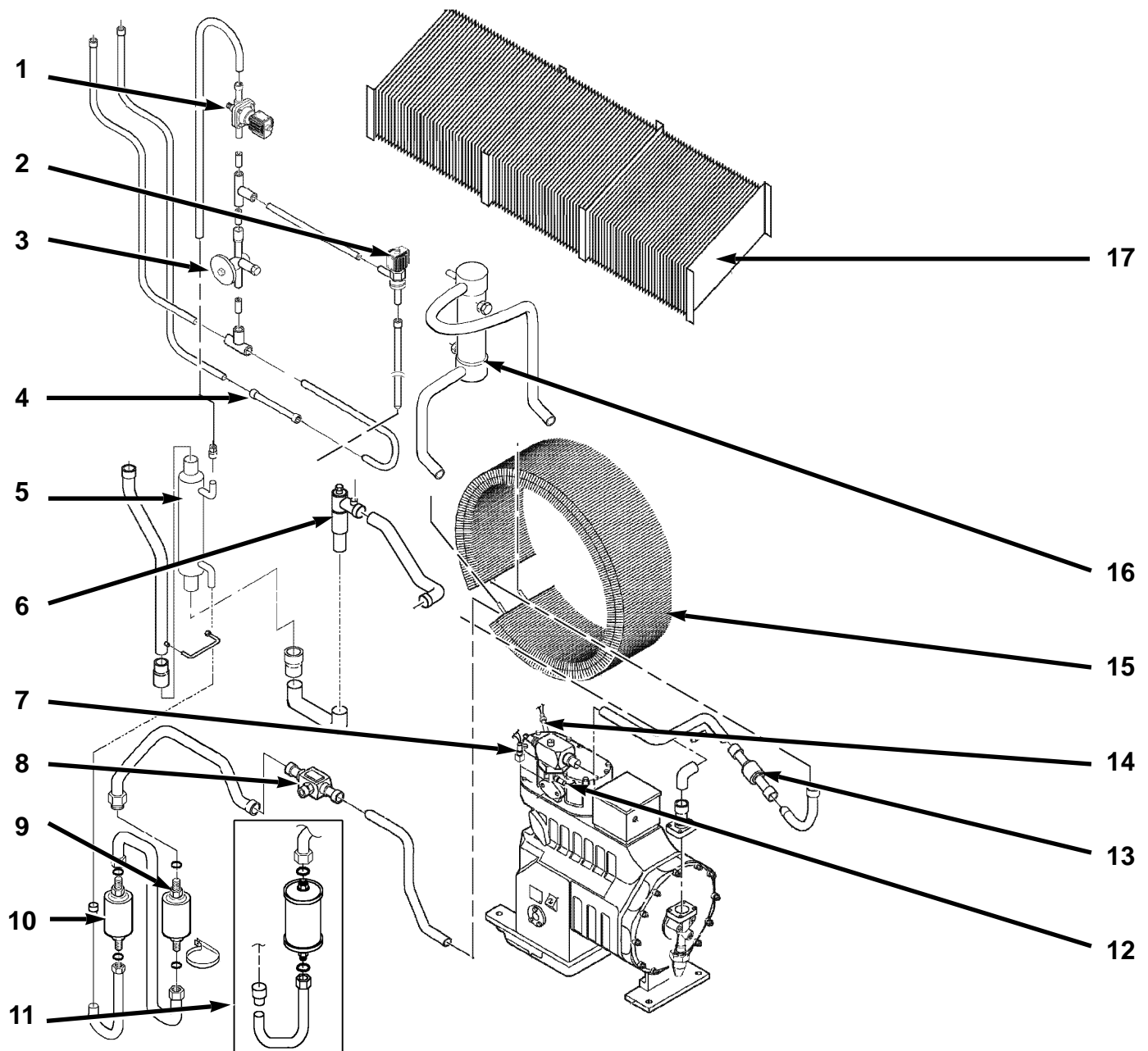

Standard Refrigeration System

- | | |
|---|--|
| 1. Liquid Line Solenoid Valve | 15. Condenser Coil |
| 2. Liquid Injection Solenoid Valve | 16. Receiver Tank with Service Port and Fusible Plug |
| 3. Expansion Valve | 17. Evaporator Coil |
| 4. Tube (Standard) | |
| 5. Heat Exchanger | |
| 6. KVK Valve (Evaporator Pressure Regulator) | |
| 7. High Pressure Cutout Switch | |
| 8. Liquid Line Service Valve | |
| 9. In-line Filter (Units before 3/9/99) | |
| 10. Filter Drier (Units before 3/9/99) | |
| 11. One-piece Filter Drier/In-line Filter (Units after 3/9/99 and Models with Two Evaporator Fans Only) | |
| 12. Condenser Fan Pressure Switch | |
| 13. Condenser Check Valve | |
| 14. Compressor Discharge Gas Temperature Sensor | |

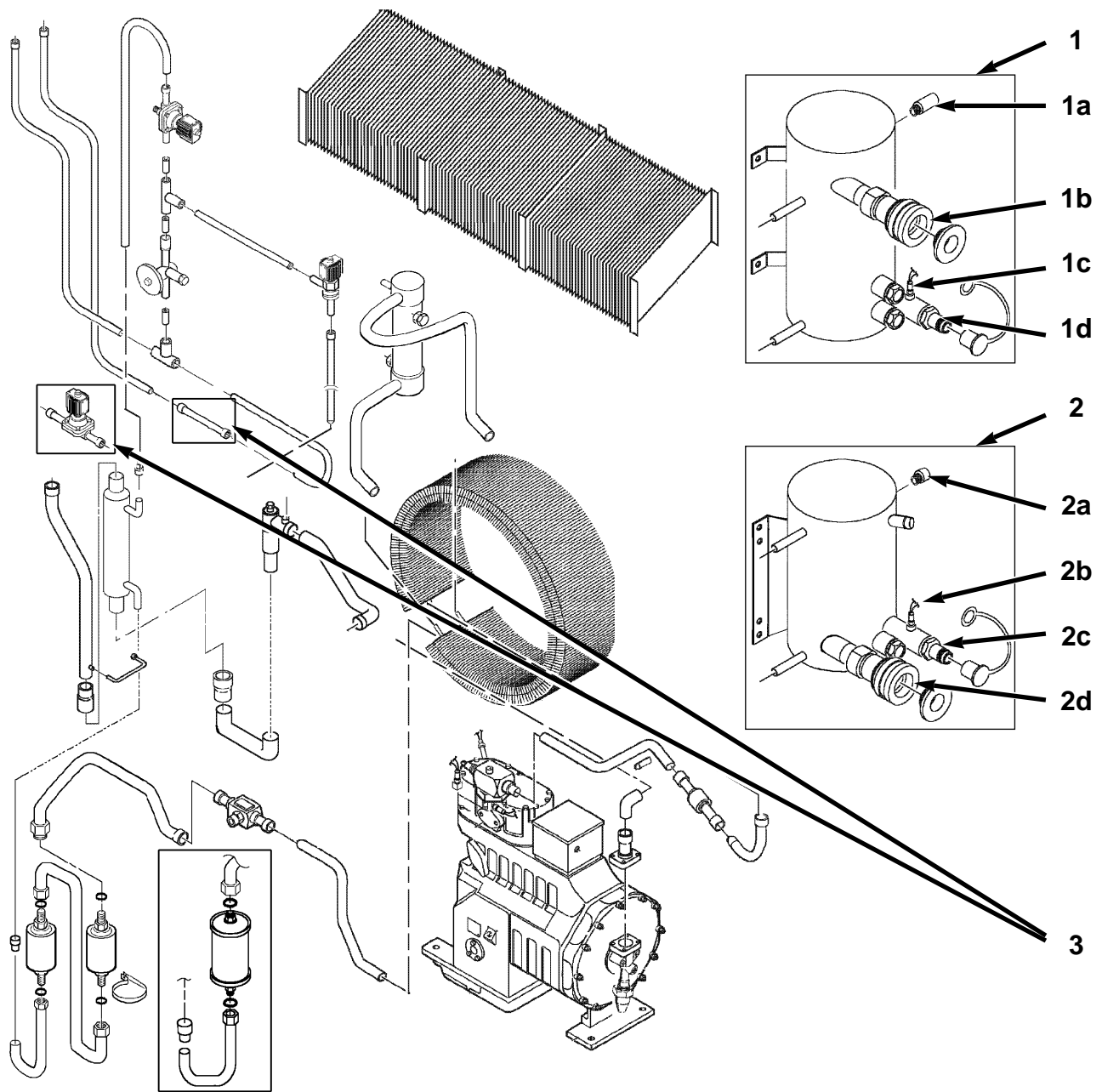

Refrigeration System Options

1. Water-Cooled Condenser-Receiver Tank Option (Before 8/99)
 - 1a. High Pressure Relief Valve
 - 1b. Water Outlet Coupling
 - 1c. Water Pressure Switch
 - 1d. Water Inlet Coupling
2. Water-Cooled Condenser-Receiver Tank Option (After 8/99)
 - 2a. Fusible Plug
 - 2b. Water Outlet Coupling
 - 2c. Water Pressure Switch
 - 2d. Water Inlet Coupling
3. Dehumidify Valve Option (Replaces Standard Tube)

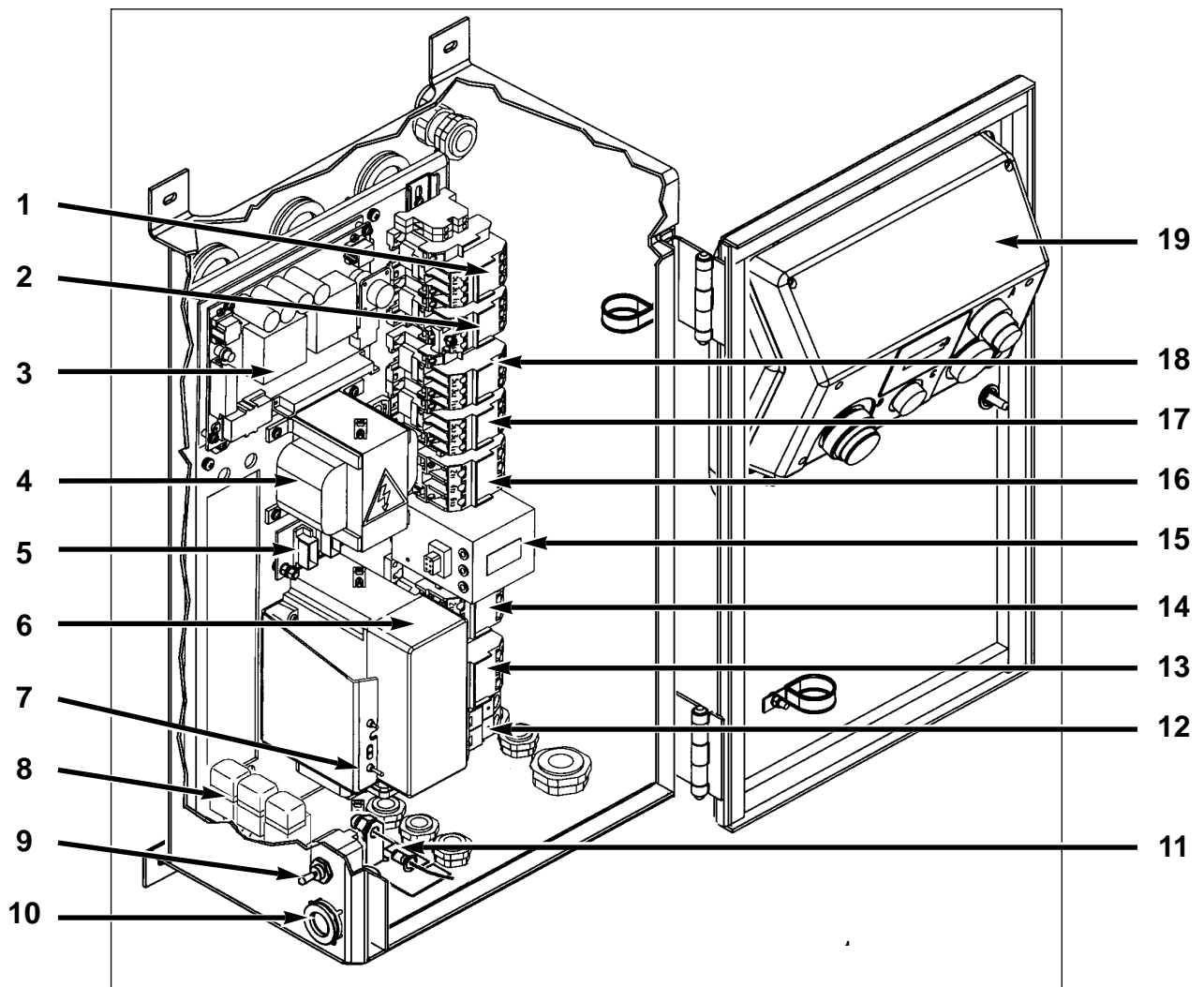

Control Box — Door Open

1. Condenser Fan Contactor
2. Evaporator Fan Low Speed Contactor
3. Power Module
4. Control Transformer
5. Thermo Bus Tap
6. Output Module
7. Emergency Bypass Module
8. Remote Monitor Option Relays; 4-Pin plug is located on side of control box (bottom of control box on CRR-20SL-63)
9. Unit On/Off Switch
10. Data Retrieval Receptacle (located on bottom of control box on some models)
11. Thermistor Lead Option
12. Main Circuit Breaker
13. CBA Phase Contactor
14. ABC Phase Contactor
15. Current Transformer
16. Compressor Contactor
17. Heater Contactor
18. Evaporator Fan High Speed Contactor
19. µP-D Controller

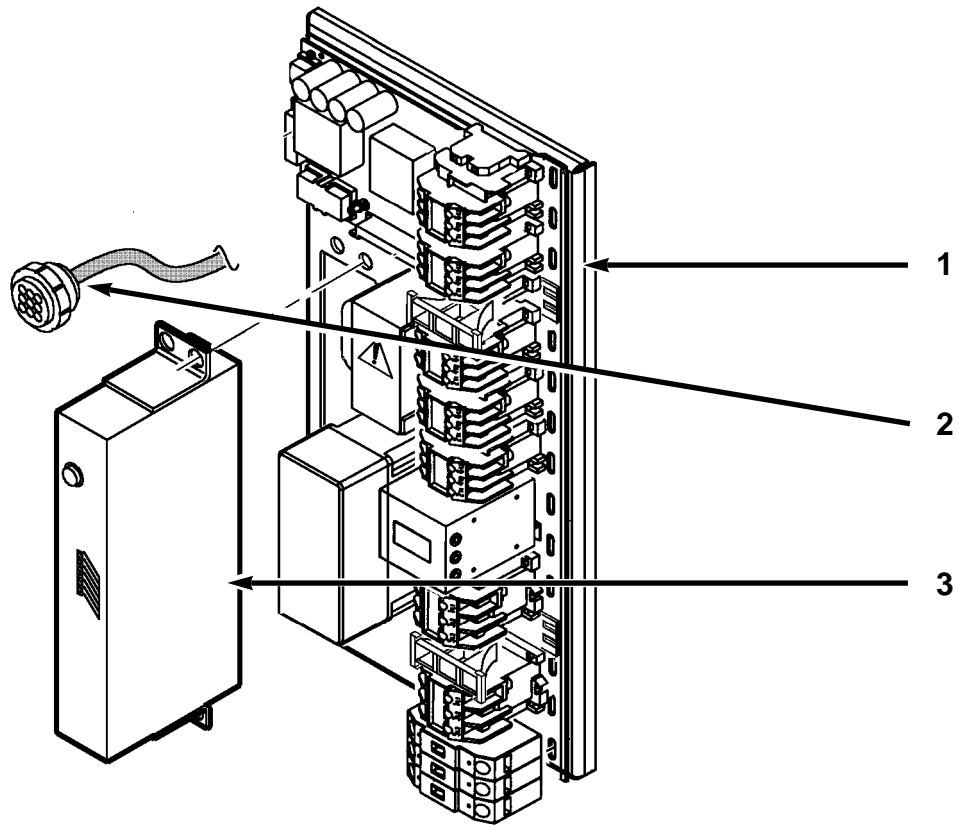
**Sabroe or RTE Remote Monitor Modem Option for Power Line Communications**

1. High Voltage Tray in Control Box
2. Modem Plug and Harness
3. Sabroe Controls or RTE Modem

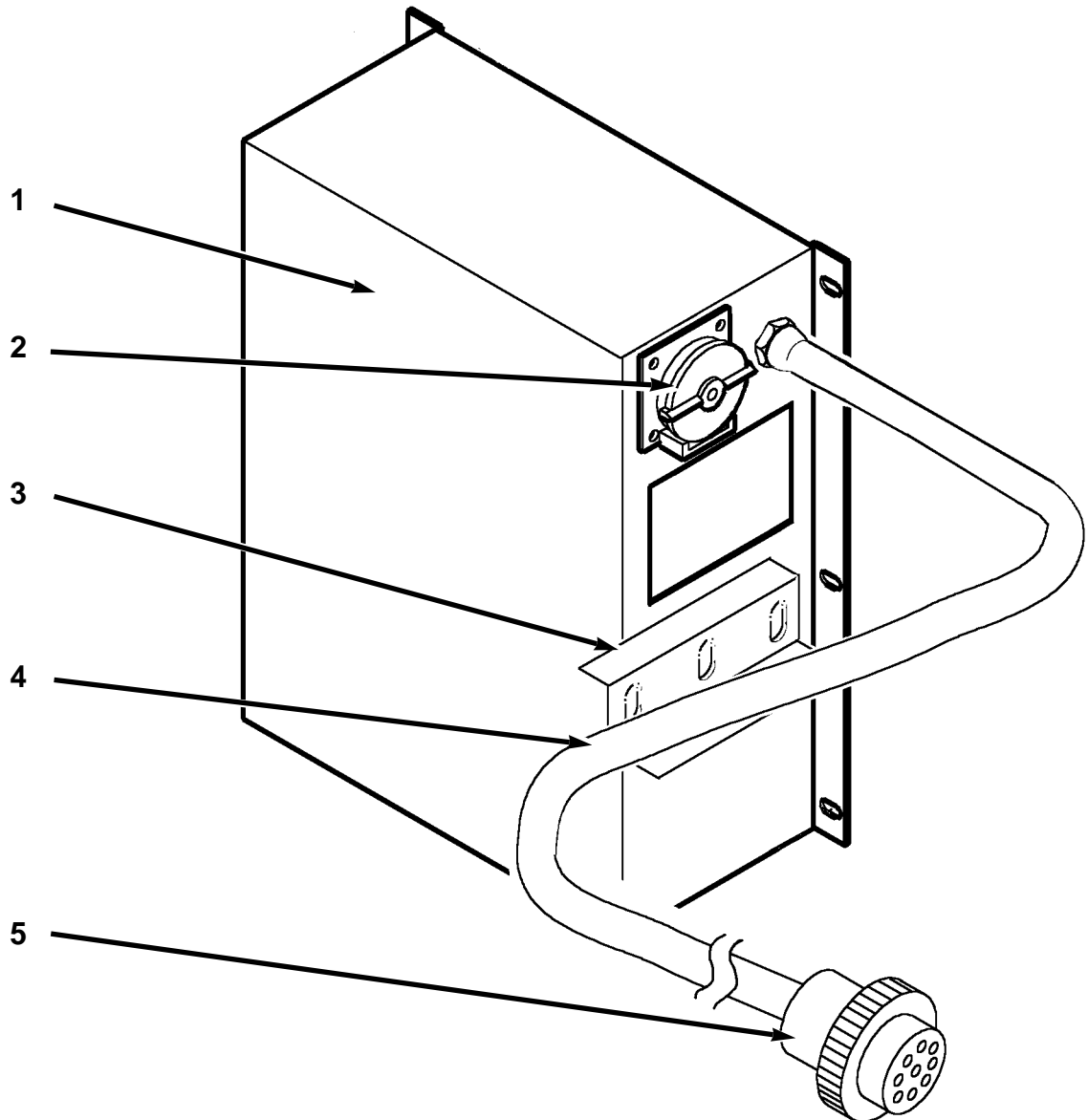
**Dual Voltage Option**

1. 15 KVA Transformer
2. 460-380V Power Receptacle
3. Cable Bracket
4. 230-190V Power Cable
5. Power Plug (Option)

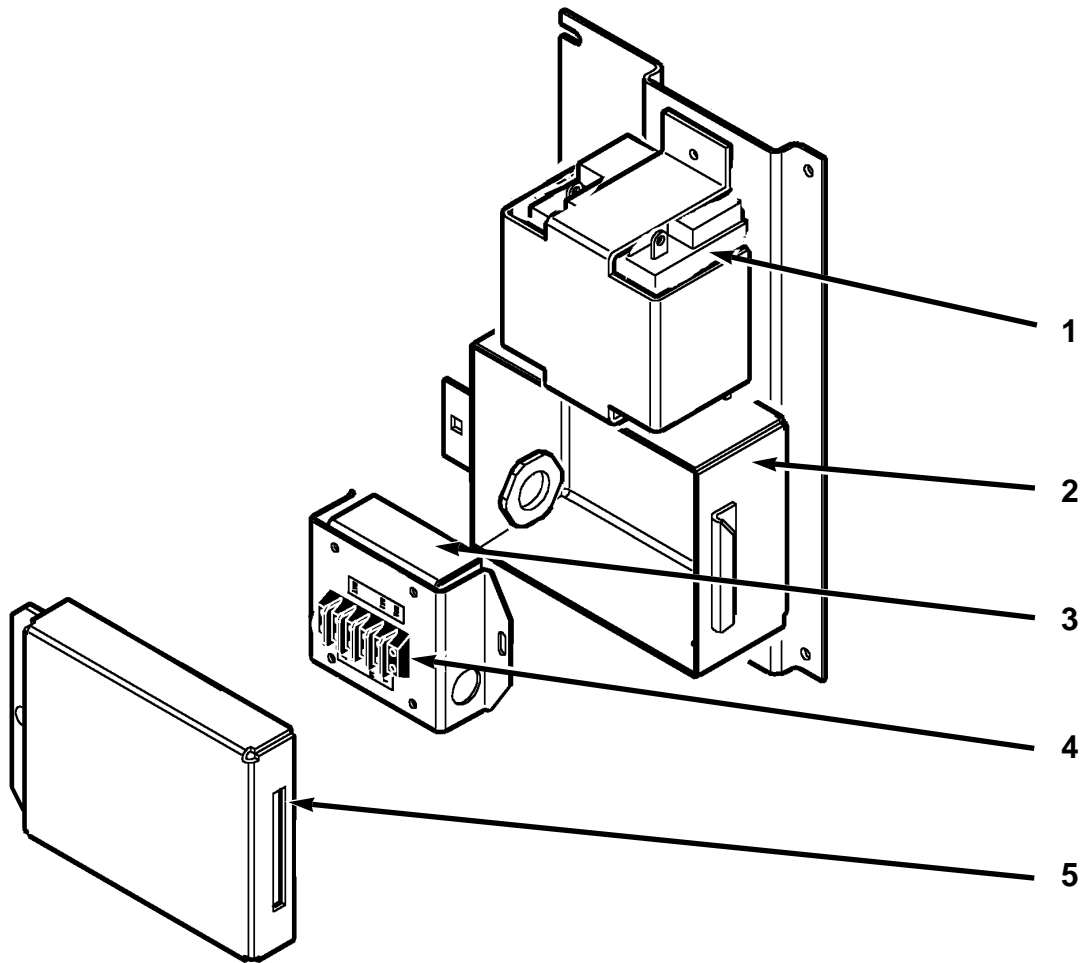

Auxiliary Battery and Battery Charger Option

1. 12 Vdc Battery
2. Battery Charger Box
3. Battery Charger
4. Terminal Board
5. Battery Charger Cover

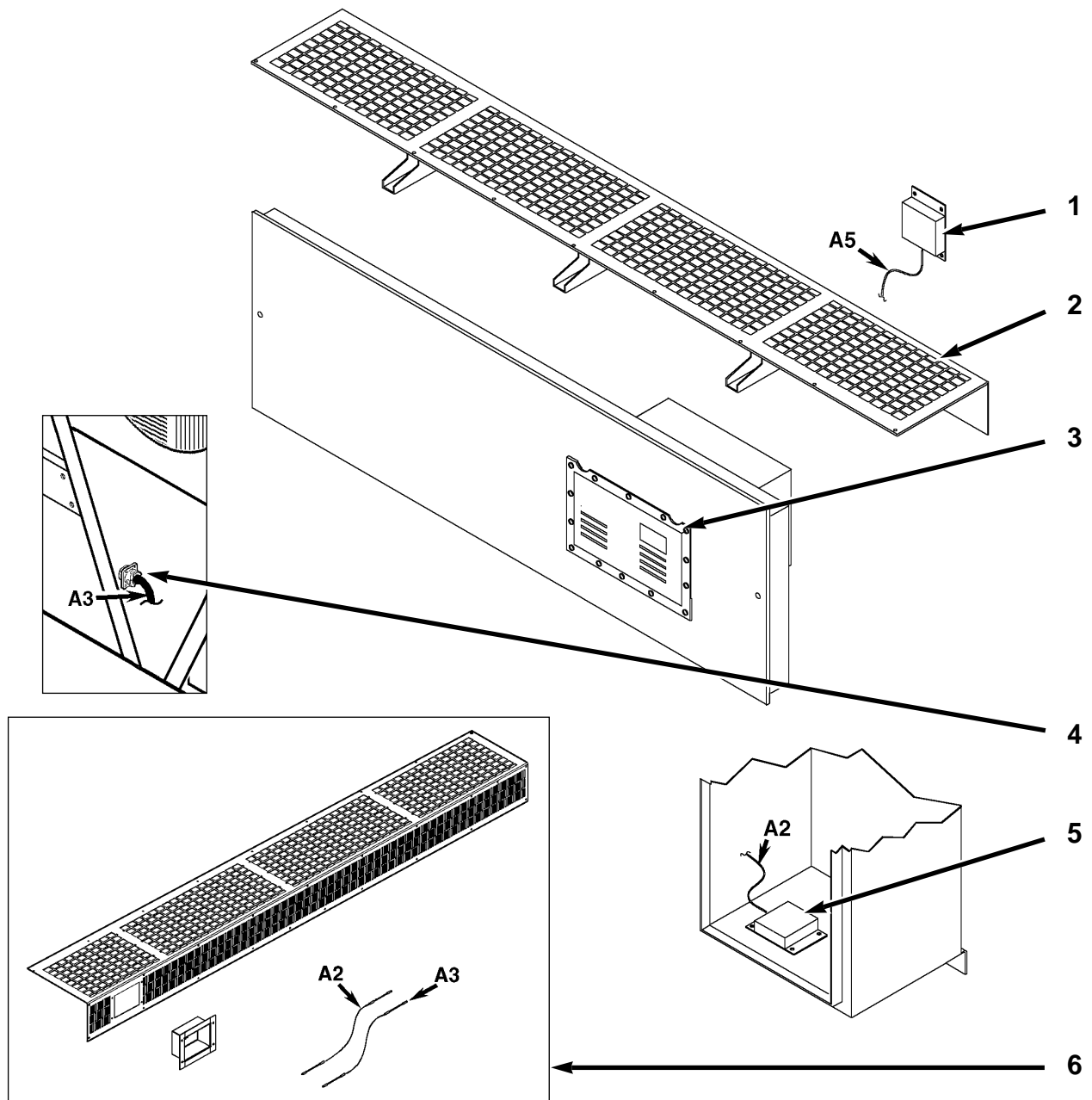

TRANSFRESH System Options

1. TRANSFRESH Scrubber Connection and A5 Wire Harnesses
2. Evaporator Grille
3. TRANSFRESH Door Assembly
4. TRANSFRESH Download Port
5. Transformer Assembly mounted in Control Box
6. TRANSFRESH Provision Option includes:
 - TRANSFRESH Box
 - A2 Wire Harness to TRANSFRESH Transformer
 - A3 Wire Harness to TRANSFRESH Download Port
 - Evaporator Grille

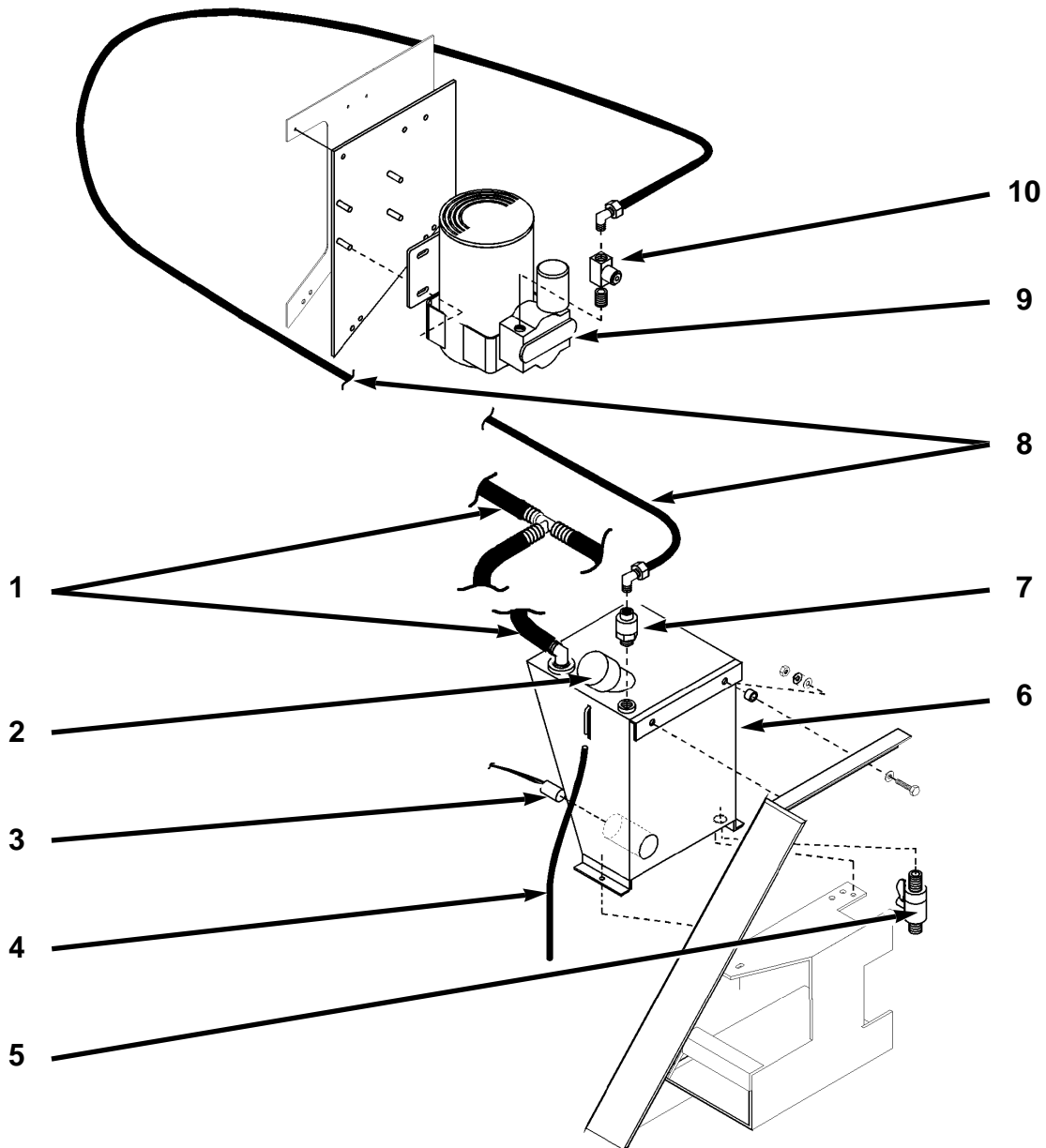

Humidify System Option

1. Evaporator Drain Hose
2. Fill Cap
3. Water Tank Heater
4. Tank Overflow Hose
5. Drain Cock
6. Water Tank
7. Water Filter
8. Water Supply Hose
9. Air Compressor
10. Liquid Spray Nozzle

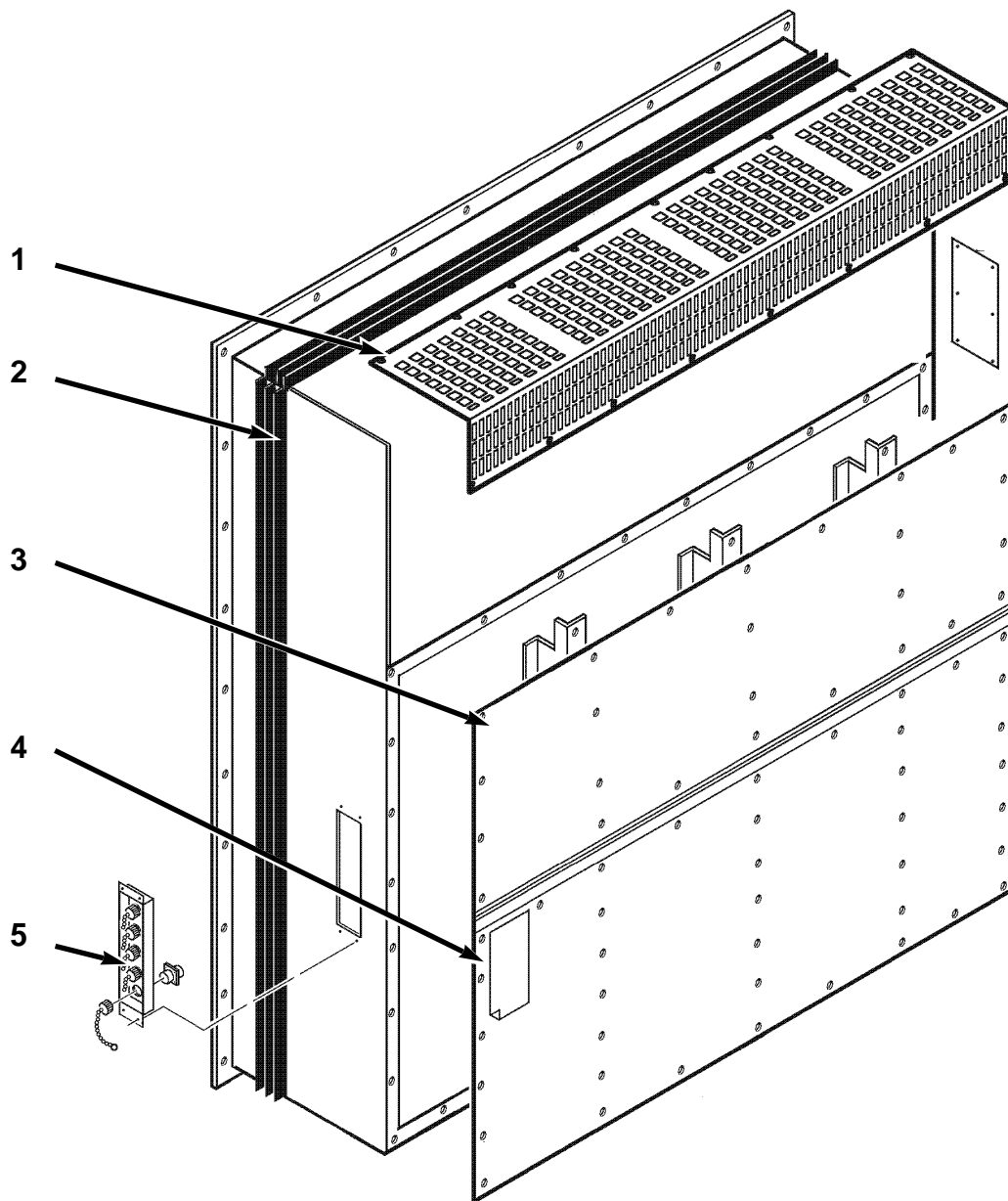
**Typical Unit Back View**

1. Evaporator Grille
2. Unit Gasket
3. Top Rear Plate
4. Bottom Rear Plate
5. Sensor Connector Assembly:
 - Controller Communications and Data Download Port
 - Cargo (Pulp) Sensor Connection
 - USDA1 Sensor Connection
 - USDA2 Sensor Connection
 - USDA3 Sensor Connection

3

Operating Instructions

Unit Controls

Unit Control Box

1. ON/OFF SWITCH.
 - a. ON position. Unit will operate on cool or heat depending on the controller setpoint temperature and the container air temperature.
 - b. OFF position. The unit will not operate.

µP-D Controller

The Thermoguard® µP-D microprocessor controls all unit functions to maintain the cargo at the proper temperature. The controller also monitors and records system faults, limits power demand and performs pre-trip.

Ten touch sensitive keys are used to display information, change the setpoint, change the programmable features and initiate control tasks.

1. SELECT KEY. Press this key to enter and display screens from the controller menu.
2. UP KEY. Press this key to increase the setpoint (and other settings in the menu), and scroll UP through the menu display.
3. DOWN KEY. Press this key to decrease the setpoint (and other settings in the menu), and scroll DOWN through the menu display.
4. ENTER KEY. Press this key to load the setpoint (or other setting in the menu), and execute other controller tasks.
5. C/F KEY. Press this key to view temperatures in the controller display in the alternate temperature scale. Alternate display shows while the key is pressed.

NOTE: *The C/F units shown on the controller display can be changed by pressing and holding the C/F key, and then pressing the ENTER key.*

6. RET/SUP KEY. Press this key to view the alternate sensor temperature (non-controlling sensor) in the controller display. Alternate display shows while the key is pressed.
7. DEFROST KEY. Press this key to prepare the controller to initiate a manual defrost cycle. Then press the ENTER key to LOAD a manual defrost. If the evaporator coil temperature is below 10 C (50 F), the unit will defrost. Otherwise the controller will display “DFRST INVAL” and the unit will continue normal operation.
8. PRETRIP KEY. Press this key to prepare the controller to initiate an automatic Full Pretrip test. Then press the ENTER key to LOAD a pretrip test. The controller will perform a Full Pretrip test if no alarms are present.
9. SOT KEY. Press this key to prepare to place a Start of Trip marker in the datalogger. Then press the ENTER key to LOAD the Start of Trip marker.
10. ALARM KEY. Press this key to display alarm codes when the Alarm LED is lit (or flashing). Press the DOWN arrow key to view additional alarm codes that may be present. After viewing, writing down and correcting all alarm conditions, press the ENTER key to clear alarms.

Other Unit Controls

1. CONDENSER FAN PRESSURE SWITCH. The controller determines condenser fan operation based on the condenser fan pressure switch input. When the condenser head pressure rises above 1380 +/- 50 kPa, 13.80 +/- 0.5 bar, 200 +/- 7 psig; the condenser fan pressure switch opens, causing the controller to start the condenser fan. When the condenser head pressure falls below 1100 +/- 50 kPa, 11.00 +/- 0.5 bar, 160 +/- 7 psig; the condenser fan pressure switch closes, causing the controller to stop the condenser fan.

NOTE: *When unit configurations 5015 or 5016 are loaded (CRR-40-52 units), the controller uses the compressor discharge temperature and/or*

condenser coil temperature input to cycle the condenser fan between ON and OFF.

2. WATER PRESSURE SWITCH (OPTION). When water pressure greater than 117 +/- 21, 1.17 +/- 0.21 bar, 17 +/- 3 psig is provided to the condenser-receiver tank, the water pressure switch opens. This causes the controller to stop condenser fan operation. When the water pressure decreases below 35 +/- 21 kPa, 0.35 +/- 0.21 bar, 5 +/- 3 psig, the switch closes, causing the controller to place the unit on air-cooled condenser fan operation.

NOTE: Water-cooled condenser operation requires a water flow of 19 to 38 l/min. (5 to 10 gal./min.).

Unit Instruments

1. STATUS INDICATOR LEDs are located on the μ P-D controller and signal the following:
 - Cool
 - Modulation
 - Null
 - Heat
 - In-Range
 - Defrost
 - Supply
 - Return
 - Power Limit
 - Alarm

The In-range LED illuminates when the controlling air sensor temperature is between 1.7 C (3.0 F) above setpoint and 2.5 C (4.5 F) below setpoint. The controller inhibits the out-of-range alarm during defrost.

NOTE: The controller will not respond to an out-of-range condition for 75 minutes to avoid nuisance alarms.

2. RECEIVER TANK SIGHT GLASS. A sight glass on the receiver tank contains three small balls that indicate the level of refrigerant in the tank for checking the refrigerant charge. A moisture indicator in the sight glass changes color to indicate the level of moisture in the system. Check the color of the indicator against the color decal in the sight glass. The dry eye in the sight glass is LIGHT GREEN when the system is dry and YELLOW when the system is wet (contains excessive moisture).
3. COMPRESSOR OIL SIGHT GLASS. A compressor oil sight glass indicates the relative level of compressor oil in the compressor sump.

4. SUCTION PRESSURE GAUGE (OPTION). A suction pressure gauge indicates the refrigerant pressure in the suction line returning to the compressor. See "Normal R-134a System Suction Pressures" table in the Refrigeration Maintenance and Service Operations chapter for normal suction pressure readings.
5. DISCHARGE PRESSURE GAUGE (OPTION). A discharge pressure gauge indicates the refrigerant pressure in the discharge line leaving the compressor.
6. THERMISTOR LEAD (OPTION). A thermistor lead is located in the unit control box to provide air temperature verification. The bulb of the thermistor lead is attached to the return or supply air sensor in the evaporator section.
7. REMOTE MONITOR CONNECTOR, 4-PIN (OPTION). A receptacle is provided on the side of the control box for connecting the ship's 4-pin bridge light system to the unit. The connector provided circuits for Compressor On, Defrost and In-range. The remote in-range light is activated when the controlling air sensor temperature is between 1.7 C (3.0 F) above setpoint and 2.5 C (4.5 F) below setpoint.
8. RECORDING THERMOMETER (OPTION). The recording thermometer indicates and permanently records the temperature of the air returning to the evaporator section on a calibrated chart.
9. POWER LINE COMMUNICATIONS MODEM (OPTION). Several models remote monitoring modems are available to provide remote monitoring via the power cable. High speed transmission reads all controller information.
 - Thermo King modem is installed in a self-enclosed box bolted above the compressor.
 - Sabroe Controls modem is installed in the electrical control box.
 - RTE modem is installed in the electrical control box.



Receiver Tank Sight Glass

1. Moisture Indicator: Light Green = Dry
Yellow = Wet
2. Outer ring is color coded. Compare to indicator.

Unit Protection Devices

1. **CIRCUIT BREAKERS.** A 25 ampere manual reset circuit breaker protects the 460/380V power supply circuit to the unit electric motors and control system transformer. The main power circuit breaker is located in the control box.
2. **FUSES.** A number of fuses located in the power module protect unit circuits and components.
 - A 2 amp fuse (F1) protects the circuit to the modulation valve.
 - A 1 amp fuse (F2) protects the bridge light relay (option) circuit.
 - A 1 amp fuse (F3) protects SPARE circuit terminals.
 - A 5 amp fuse (F4) protects the circuit that supplies power to Power Module Board.
 - A 1 amp fuse (F5) protects the bridge light (option) circuit.
 - A 5 amp fuse (F6) protects SPARE circuit terminals.
 - A 3 amp fuse (F7) protects the TRANSFRESH (option) circuit.
 - A 2 amp fuse (F8) protects the IRMU (option) circuit.
 - A 3 amp fuse (F9) protects SPARE circuit terminals.
 - A 3 amp fuse (F10) protects the battery charger (option) power input circuit.
 - A 7.5 amp fuse (F11) protects the Output Module circuit.
 - A 3 amp fuse (F12) protects the battery pack connector circuit.
 - A 3 amp fuse (F13) protects the battery charger (option) output circuit.
 - A 3 amp fuse (F14) protects the battery (option) circuit.
3. **COMPRESSOR DISCHARGE GAS TEMPERATURE SENSOR.** A refrigerant injection system uses the compressor discharge gas temperature sensor to determine when cold refrigerant will be injected into the compressor suction line. Liquid injection protects the compressor from excessively high operating temperatures. At compressor discharge gas temperature above 138 C (280 F), the controller energizes the liquid injection valve. When the discharge gas temperature drops to 132 C (270 F), the controller de-energizes the injection valve to stop refrigerant injection.

If the discharge gas temperature rises above 148 C (298 F), the controller immediately stops the compressor and evaporator fans. The condenser fan and phase select outputs remain energized as the controller operates the condenser fan to correct the condition. The controller display will show "PAUSE ALM82" for 1 second every 10 seconds. After 5 minutes, the controller attempts to restart the compressor. If the compressor still fails to start, fault code 82 (Compressor Head Over Temperature) is generated. The controller will restart the compressor when the fault condition corrects itself (resets).
4. **EVAPORATOR OVER TEMPERATURE PROTECTION.** An evaporator coil sensor monitors coil temperature during heat and defrost modes. If the coil sensor temperature reaches 38 C (100 F), the controller de-energizes the heater contactor. If the coil sensor reaches 50 C (122 F), the controller also de-energizes the evaporator fan and phase select contactors; and generates a shutdown Alarm. Fault code 09 (Evaporator Coil Over Temperature) is displayed on the controller display when the ALARM key is pressed.
5. **HIGH PRESSURE CUTOUT (HPCO) SWITCH.** The refrigerant high pressure cutout opens, interrupting 24 Vac control power to the compressor contactor if the compressor discharge pressure rises above 2410 +/- 70 kPa, 24.10 +/- 0.7 bar, 350 +/- 10 psig. This immediately stops the compressor and evaporator fans. The condenser fan and phase select outputs remain energized as the controller operates the condenser fan to correct the condition. The controller display will show "PAUSE ALM10" for 1 second every 10 seconds.

After 5 minutes, the controller attempts to restart the compressor. If the compressor fails to start, fault code 10 (High Pressure Cutout) is generated. The controller will restart the compressor when the fault condition corrects itself (resets). The high pressure switch resets (closes) when the pressure drops back to 1655 +/- 70 kPa, 16.55 +/- 0.7 bar, 240 +/- 10 psig.
6. **FUSIBLE PLUG FOR HIGH PRESSURE RELIEF.** A fusible plug is installed in the standard receiver tank to avoid excessive pressure build-up within the refrigeration system from extraordinary and unforeseen circumstances. The plug blows when the plug temperature reaches 100 C (212 F). The plug is located so that refrigerant pressure expelled from the valve would be directed away from anyone servicing the unit. The plug is non-repairable and requires no adjustment. If the plug blows, recover the remaining refrigerant charge and replace the fusible plug.
7. **HIGH PRESSURE RELIEF VALVE (OPTION).** A high pressure relief valve is installed in the water-cooled condenser-receiver tank to avoid excessive pressure build-up within the refrigeration system from extraordinary and unforeseen circumstances. The valve is a spring-loaded piston that lifts when refrigerant pressure exceeds 3447 +345/-104 kPa, 34.47 +3.45/-1.04 bar, 500 +50/-15 psig. The valve is located so that refrigerant pressure expelled

from the valve would be directed away from anyone servicing the unit. The valve will reset when this pressure drops to 2758 kPa, 27.58 bar, 400 psig. The valve is non-repairable and requires no adjustment. If the valve fails to reseat properly, recover the refrigerant charge and replace the valve.

8. **OVERLOAD PROTECTION.** The condenser fan motor, evaporator fan motors and compressor motor include internal overload protection with automatic reset.
9. **PHASE SEQUENCE SELECTION.** When the On/Off switch is turned ON, the controller display shows “Phase Check” while it determines the correct phase sequence. Phase selection takes 50 to 80 seconds; or more on extremely noisy power lines. The controller then energizes phase select contactor ABC or CBA to ensure proper condenser fan, evaporator fan and compressor rotation.

Pretrip Inspection

Visual Inspection

The following visual inspections should be made before the container is loaded:

1. Visually check the unit for physical damage.
2. Check the electrical connections in the unit control box, making sure they are fastened securely.
3. Check the conditions of wires and terminals. Repair or replace if necessary.
4. Check the refrigeration system for leaks. Inspect for evidence of oil leaks at all joints and connections.
5. Check the condenser and evaporator coils. Clean if necessary. Use an air or water spray jet directed against the coil from the air discharge side. Also inspect the condenser fan grille for damage. If the grille is damaged or missing, abnormally high head pressure may result. Repair or replace the grille if necessary.

CAUTION: Air or water spray jet pressure should not be high enough to damage (bend) coil fins.

6. Check the mounting bolts on the unit, compressor and fan motors. Tighten if necessary.
7. Clean the defrost drains.
8. Optional: Inspect water-cooled condenser-receiver tank, water lines and fittings for water leaks. When water lines are disconnected, also check to be sure that the water drains completely from the condenser-receiver tank.

Report defective fittings and tanks that do not drain to a technician.

9. Optional: Check water level in humidity system tank. Add only demineralized or distilled water to prevent plugging of the atomizing nozzle.
10. Observe the unit for proper operation and functions during Pre-load Operation.

Functional Inspection

To properly perform a Full Pretrip Test on units equipped with the μ P-D controller, the container must be empty with the rear doors closed.

1. Start the unit (see “Starting the Unit and Adjusting the Controller Setpoint” on page 3-6). A second sequence start of the required loads occurs during initial start-up of the unit.
 - The status Indicator LEDs and display turn On and then Off.
 - The controller display shows “Phase Check” while it determines the correct phase sequence. Phase selection takes 50 to 80 seconds; or more on extremely noisy power lines. Phase select contactor ABC and the electric heaters, condenser fan and evaporator fans are energized for 10 seconds. Phase select contactor ABC is then de-energized. 30 seconds later, phase select contactor CBA and the electric heaters, condenser fan and evaporator fans are energized for 10 seconds. The controller then turns OFF all unit loads and energizes phase select contactor ABC or CBA.
 - The setpoint and controlling air sensor temperature are displayed.
 - Controller energizes unit loads, starting the evaporator fans. The condenser fan may also start (if required).
 - If the controller calls for cooling, the compressor motor starts. If the unit starts in Modulation Cool, compressor start-up can be delayed up to 3 minutes while the evaporator pressure regulator (KVQ) valve opens or closes to the required setting.
 - If the controller calls for heating, the electric heaters are energized.

NOTE: If the unit does not start, turn the On/Off switch OFF. Check power supply. Then repeat step 1. If the unit still does not start, refer to “Alarm Codes, Descriptions and Corrective Actions” in the μ P-D Controller chapter of this manual. Be sure to wait up to 3 minutes for the compressor to start.

2. Check controller setpoint for proper setting. Adjust if necessary.
3. Check the direction of the condenser airflow (see “Condenser Fan and Evaporator Fan Rotation” in the Electrical Maintenance chapter of this manual).
4. Check direction of evaporator airflow (see “Condenser Fan and Evaporator Fan Rotation” in Electrical Maintenance chapter of this manual).
5. Perform a Full (or Extended) Pretrip Test and check unit modes while the unit pre-cools:

NOTE: An Extended Pretrip test can take up to 7 hours to complete.

- Press the PRETRIP key. The left display flashes “ENTER” and the right display flashes “PTRIP”.
- Press the ENTER key. “LOAD PTRIP” briefly appears in the display.

NOTE: If Alarm Code(s) are stored in the controller when the ENTER key is pressed, the display briefly shows “CLEAR ALARM”. The display then returns to the Standard Display. Correct the alarm condition(s) and clear the alarm code(s) before attempting a Pretrip Test.

NOTE: To perform an Extended or Single Pretrip Test, see “Pretrip Tests” in the μ P-D Controller chapter of this manual.

- The controller then performs the Full (or Extended) Pretrip Test.

NOTE: If the container temperature is below 0 C (32 F), the controller places the unit in the HEAT mode when a Full or Extended Pretrip Test is initiated. The test begins when the container temperature increases to 0 C (32 F).

- Observe the unit for proper operation and functions during pretrip test.
- If the unit passes the Full Pretrip test, “PTRIP PASS” is stored in the datalogger memory and the unit returns to normal operation. A Start of Trip (SOT) marker is also recorded in the data logger memory when an automatic Full or Extended Pretrip is successfully completed.
- If an operating problem is encountered during the Full Pretrip Test, the Alarm LED will turn ON, “PTRIP FAIL” is stored in the datalogger memory and the unit returns to normal operation (unless a shutdown fault has

occurred). View and correct any alarm conditions. Then clear the Alarm Code(s) and repeat the pretrip test.

NOTE: PASS or FAIL is recorded in the datalogger memory and can be viewed through the controller’s VIEW/LOG/PT1 submenu. For instructions on viewing the VIEW/LOG/PT1 submenu, refer to “Viewing Information in the View Menu” in the μ P-D Controller chapter of this manual.

NOTE: Clear the Alarm codes ONLY after the alarm codes are documented and problems repaired. Clearing the codes erases them from the display memory of the controller.

However, a permanent record of the alarm codes remains stored in the datalogger memory of the controller for retrieval via PC-PAC™ software.

WARNING: Some unit malfunctions will cause an Alarm and unit shutdown condition. When the alarm codes are cleared, the unit will start automatically.

6. Allow the unit to operate in the cool mode for 30 minutes before loading the container. This will remove residual container heat and moisture, and pre-cool the container interior.
 7. Enter trip ID information into the controller memory using the PC-PAC™ software (see instructions of PC-PAC™ software).
 8. Set the fresh air vent to the desired air exchange rate.
- NOTE: If Dehumidification is turned ON, the fresh air vent should be closed.**
9. Optional: Operate the humidity system (see “Humidify Mode” on page 4-39). Verify that the air compressor operates and that water is drawn into the atomizing nozzle and injected into the return air stream (see “Humidify System” on page 7-7).
 10. Install a new chart and prepare the recording thermometer for temperature recording (if so equipped):
 - Wind the chart drive on the recording thermometer (Partlow recorders).
 - Check the battery charge on the recording thermometer (Saginomiya recorders).
 11. Stop the unit by moving the On/Off switch to the OFF position.

Starting the Unit and Adjusting the Controller Setpoint

CAUTION: Supply power connections from the unit to the power source must always be made with the refrigeration Unit On/Off switch and power supply On/Off switch in the OFF positions. Never attempt to start or stop the refrigeration unit with the unit power cable.

1. Connect the unit power cord to proper power source:
 - 460/380V power cord to 460/380V, 60-50 Hz power source.
 - For operation on 230/190V power, insert the 460/380V power plug into the dual voltage transformer receptacle. Then connect the 230/190V power cord to a 230/190V, 60-50 Hz power source.
 - Turn the power supply On/Off switch ON.
2. Turn the unit On/Off switch to ON position. Check for condenser fan and evaporator fan motor operation (see “Condenser Fan and Evaporator Fan Rotation” in the Electrical Maintenance chapter of this manual). If the unit was properly pretripped, correct condenser fan rotation will also indicate correct evaporator fan rotation.
3. Adjust controller setpoint to the desired temperature:
 - Press the UP or DOWN arrow key to increase or decrease the setpoint. The left display flashes “SETPT” while the right display shows the temperature.
 - Wait four seconds for all three digits to appear on the right display. Make additional setpoint adjustment if necessary.
 - Press the ENTER key when the desired setpoint shows in the right display. The right display briefly shows LOAD”. The controller then returns to the Standard Display (showing new setpoint).

NOTE: If the ENTER key is not pressed within 10 seconds, the controller will default (return) to the previous setpoint. If this occurs, repeat step 3.

Loading Procedure

1. Make sure the Unit On/Off switch is OFF before opening the container doors. (The unit may be operating when loading the container from a warehouse with door seals.)
2. Spot check and record load temperature while loading. Especially note any off-temperature product.

Post Load Procedure

1. Make sure all doors are closed and locked.
2. Start unit if unit is OFF.
3. Check controller setpoint for proper setting.
4. If trip ID information has NOT been entered in the controller, enter it now using the PC-PAC™ software (see instructions of PC-PAC™ software).
5. One-half hour after loading, initiate a manual defrost cycle:
 - Press the DEFROST key. The display flashes “ENTER DFRST”.
 - Press the ENTER key. “LOAD DFRST” briefly appears in the display. The Defrost LED turns ON as the unit enters Defrost. The controller then returns to the Standard Display. Defrost will stop automatically.

NOTE: The evaporator coil temperature must be below 10 C (50 F) to allow the unit to enter a defrost cycle. If the evaporator coil temperature is too high, the controller display will show “DFRST INVAL” (defrost invalid) for 3 seconds. The controller then returns to the Standard Display.

Post Trip Procedure

Trip data recorded by the Thermoguard® µP-D controller may be down loaded using PC-PAC™ software via the communications connection located on the bottom of the control box. See instructions in PC-PAC™ software manual, TK P/N 204-988.

General Description

The μP-D controller is a programmable microprocessor that controls all unit functions to maintain the cargo at the proper temperature. The controller contains the following basic features:

1. Two digital displays:
 - SETPOINT: Five alpha numeric characters: Numerical tens, ones and tenths position, a C for Celsius or F for Fahrenheit for temperature display.
 - TEMPERATURE: Five alpha numeric characters: Numerical hundreds, tens, ones and tenths position, a C for Celsius or F for Fahrenheit for temperature display.
2. Ten control keys:
 - SELECT: Press to select prompts and display screens from controller menu.
 - UP: Press to increase the setpoint or scroll UP through controller menu.
 - DOWN: Press to decrease the setpoint or scroll DOWN through controller menu.
 - ENTER: Press to load the setpoint (or other setting) and execute other controller tasks.
 - C/F (Temperature): Press to view alternate temperature scale in display.
 - RET/SUP (Temperature): Press to view alternate return/supply sensor temperature.
 - DEFROST: Press to prepare to initiate a manual defrost.
 - PRETRIP: Press to prepare to initiate a Full Pretrip Test.
 - SOT (Start of Trip): Press to prepare to place Start of Trip marker in the datalogger.
 - ALARM: Press to view alarm codes that are present.

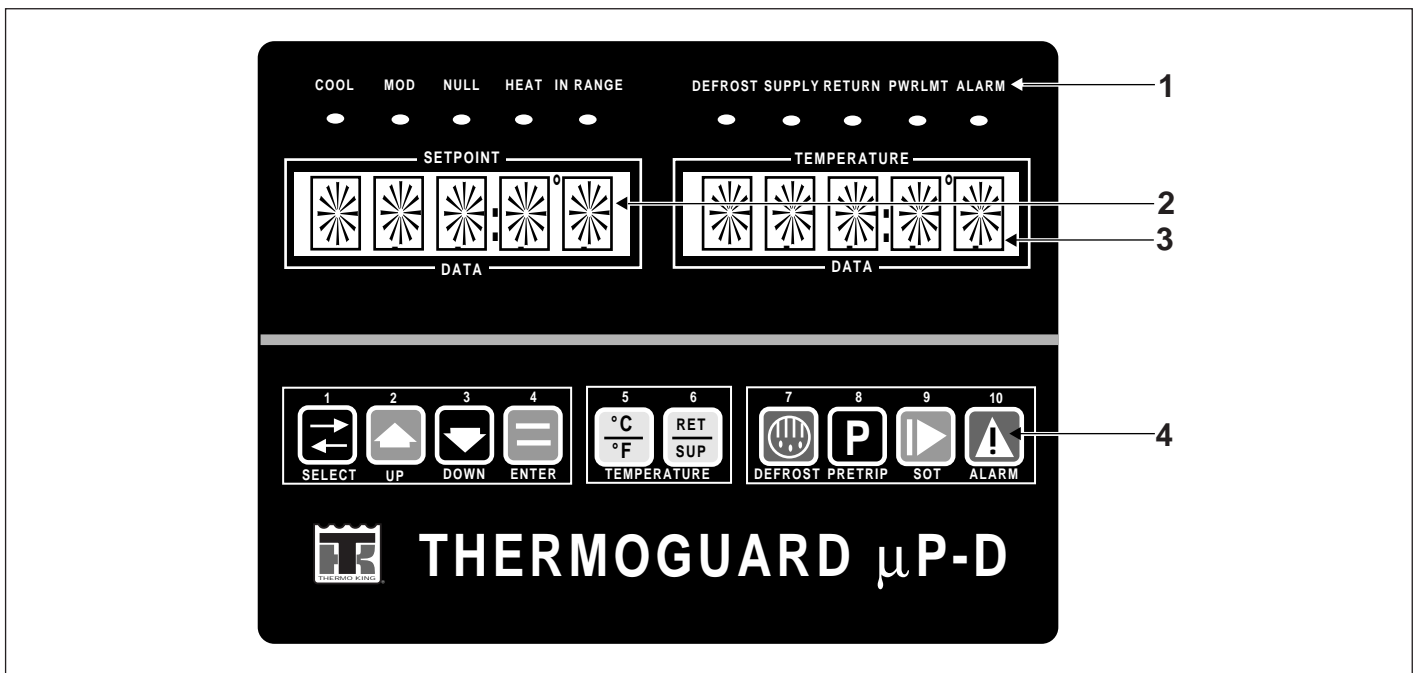

μP-D Controller

1. Status Indicator Lights
2. Setpoint (Left) Display
3. Temperature (Right) Display
4. Keypad

3. Status indicator LEDs (see “Status Indicator LEDs and Alarm Codes” in this chapter).
 4. Power Module: Low voltage control power and ground are supplied to the µP-D controller and Output Module. The Power Module also includes:
 - KVQ valve power output terminals.
 - Remote monitoring connection is provided by a serial communications port located on the side of the control box.
 - Control circuit fuse protection:
 - 2 amp fuse (F1) protects the circuit to the KVQ valve.
 - 1 amp fuse (F2) protects the bridge light relay (option) circuit.
 - 1 amp fuse (F3) protects SPARE circuit terminals.
 - 5 amp fuse (F4) protects the circuit that supplies power to Power Module Board.
 - 1 amp fuse (F5) protects the bridge light (option) circuit.
 - 5 amp fuse (F6) protects SPARE circuit terminals.
 - 3 amp fuse (F7) protects the TRANSFRESH (option) circuit.
 - 2 amp fuse (F8) protects the RMM/IRMU (option) circuit.
 - 3 amp fuse (F9) protects SPARE circuit terminals.
 - 3 amp fuse (F10) protects the battery charger (option) power input circuit.
 - 7.5 amp fuse (F11) protects the Output Module circuit.
 - 3 amp fuse (F12) protects the remote battery connector circuit.
 - 3 amp fuse (F13) protects the battery charger (option) output circuit.
 - 3 amp fuse (F14) protects the battery (option) circuit.
 5. Output Module: Output terminals are used to energize and de-energize unit contactors and solenoids (see “Output Module” in this chapter).
 6. Thermo Bus Tap circuit board: Serial communication commands are transmitted between the controller and the Output Module through the Thermo Bus circuit board (see “Thermo Bus Tap” in this chapter).
 7. Replaceable sensors: Return air, supply air, evaporator coil, condenser coil, ambient air and compressor discharge gas temperature sensors are field replaceable (see “Temperature Sensors” in this chapter). Four spare sensor receptacles are also provided for USDA and PULP temperature recording (optional).
 8. Defrost cycle control (see “Defrost” under Sequence of Operation in this chapter).
 9. Internal self-checking/diagnostic capability.
 10. Pretrip test capability (see “Full Pretrip Test” under Menu Test in this chapter).
 11. Sensor Check test capability (see “Sensor Check” under General Theory of Operation in this chapter).
 12. Data recording capability (see “Data Recording and Downloading Data” in this chapter).
 13. Electronic phase selection (see “Automatic Phase Selection” under General Theory of Operation in this chapter).
 14. Power limit control (see “Power Limit” under General Theory of Operation in this chapter).
 15. Sequential component start-up control: A sequence start of the required loads occurs during initial start-up of the controller and when a control mode shift requires the compressor to start (see “Compressor Soft Start Sequence” under General Theory of Operation and “Sequence of Operation” in this chapter).
 16. Evaporator fan speed and condenser fan operation control (see “Evaporator Fan Control” and “Condenser Fan Control” under General Theory of Operation in this chapter).
 17. Hourmeters: The µP-D controller has multiple built-in hourmeters that can be accessed through the Display Menu.
 18. Wake-up (setpoint enable) capability: Pressing the SELECT key (or connecting a communications cable to the Data Port on the bottom of the control box) when 12 Vdc battery power option is present awakens the controller. This capability provides auxiliary power for setpoint adjustment or downloading of controller data recording memory when a three phase power source is not available. Battery power keeps the controller energized for 1 minute unless a key is pressed on the controller keypad.
- NOTE: The battery pack connection is located on the Power Module Board inside the control box.**
19. Compressor refrigerant gas injection cycle control (see “Compressor Liquid Injection” under General Theory of Operation in this chapter).
 20. Flash memory: Flash program memory allows the application software to be updated without replacing a EPROM chip on the controller. Application software can be updated in the field using a portable computer and Thermo King flash loading program. Consequently, the field installed application software version may have a different revision number and may include control features not included in the original factory installed software. If the operation of your unit differs from the Sequence of Operation described for your unit (both unit and customer configuration block numbers) in this manual, check the unit configuration number and customer configuration number to be sure the controller is set to the proper unit and customer configuration (see “Reviewing Application Software Version” in this chapter).

Controller Display Menus

The µP-D controller contains an extensive display menu that can be navigated via keypad. The display menu is organized into five Main Menus (or groups):

NOTE: See page 9-37 to view a diagram of the complete µP-D menu.

Software Version Display

The application software version, unit configuration number and customer configuration number display when ENTER key is depressed for 3 seconds (see “Reviewing Application Software Version” in this chapter).

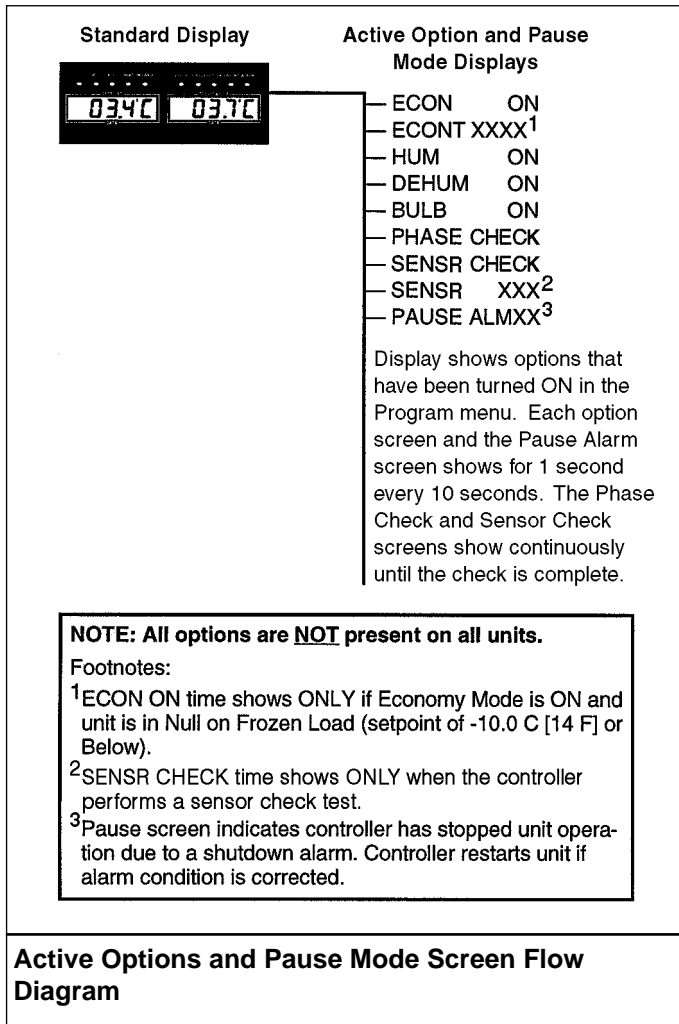
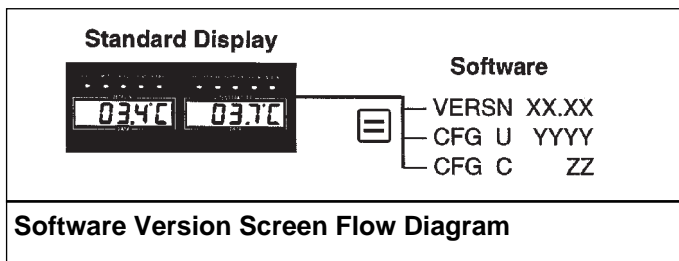

Active Option Displays

Control options that have been turned ON in the Program menu show for 1 second every 10 seconds in the controller display. For example, the Option Display for the Economy mode is shown below.

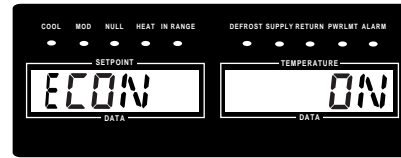

Option	Display/Description
Economy Mode	“ECON ON”/Economy mode reduces unit power consumption by reducing evaporator fan operation. “ECON XXXX”/Shows the time remaining to next controller check of return air temperature (active only during Null mode on Frozen Loads).
Humidify Mode	“HUM ON”/Humidity system operates to add moisture to the container as required to maintain humidity setpoint.
Dehumidify Mode	“DEHUM ON”/Dehumidify system operates to remove moisture from the container as required to maintain humidity setpoint.
Bulb Mode	“BULB ON”/Dehumidify system operates to remove moisture from the container as required to maintain humidity setpoint. Bulb mode allows adjustment of evaporator fan speed setting and defrost termination temperature. “DEHUM XX.X”/Current humidity level also displays briefly when the Bulb mode is ON.

Pause Mode Displays

WARNING: When the unit is in the PAUSE mode, the compressor, evaporator fans or condenser fan may continue to operate or start at any time without notice.

A Pause mode display appears when the controller interrupts normal unit operation to perform a check or test. For example, the Pause mode display for a Shutdown alarm condition is show below.

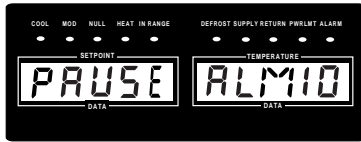

Pause Condition Display/Description

Phase Check	“PAUSE CHECK”/During initial unit start-up, the controller checks the power phase sequence for correct compressor, condenser fan and evaporator fan rotation.
Sensor Check	“SENSR CHECK”/If the supply and return air temperature difference is outside certain limits during cooling and no alarms are recorded, the controller performs a Sensor Check test. “SENSR XXX”/Shows the time remaining on the current Sensor Check test being performed.
Alarm Shutdown	“PAUSE ALMXX”/Stops unit operation due to a shutdown alarm condition. A 2-digit alarm code (“XX”) appears in Pause display to identify the alarm condition. Typically the condenser fan continues to operate while the controller attempts to correct the condition and restart the unit. The Pause mode display continues until the shutdown condition has been corrected.

View Menu

Menu screens in this group are used to display unit operating information, sensor grades and scrollback data logger data including controlling sensor temperatures and pretrip test information. No changes can be made to the data from the View menu.

Pretrip Menu

Menu screens in this group are used to activate pretrip tests including Extended Pretrip Test, Full Pretrip Test and Single Pretrip Tests.

Test Menu

Menu screens in this group are used to set the unit to specified operating conditions for system and component diagnostics.

Guarded Access Menu

Access to the menu is protected by a special security code. Menu screens in Guarded Access are used to set the unit configuration, time and date and sensor grades; enter container ID number and unit serial number; and change programmable settings via keypad.

Program Menu

Menu screens in this group are used to activate the USDA sensors, Pulp sensor, Economy mode, Dehumidify mode (and enter humidity setpoint), Bulb mode (and enter defrost termination temperature and evaporator fan motor speed), or Power Reduction mode.

Menu Display Definitions

Acronym	Definition
ALM	Alarm
ALMXX	Alarm 01, 02, 03 ...XX (total number of recorded alarms).
ALOGS	Data Logs in (P-A+ Format on Auxiliary Battery Power (Option)
AMBT	Ambient Temperature Sensor
AMP1	Total Current Phase A
AMP2	Total Current Phase B
AMP3	Total Current Phase C
AMPS	Amperage
AMTG	Ambient Temperature Sensor Grade
AUXV	Auxiliary Battery (Option) Voltage
BEFAN	Bulb Mode Enable Fan
BDFTT	Bulb Mode Defrost Termination Temperature

BULB	Bulb Mode Enable	EX DF	Extended Defrost Pretrip Test
BVS	Bypass Valve Solenoid	EX FZ	Extended Frozen Mode Pretrip Test
C/F	Temperature Display Mode	FTEST	Full Pretrip Test
CCOIL	Condenser Coil Temperature Sensor	GEN	Generator
CCTG	Condenser Coil Sensor Grade	GLOGS	Data Logs in Global Table Format on Auxiliary Battery Power (Option)
CFG C	Customer Configuration Setting	GRADE	Sensor Grade Submenu
CFG U	Unit Configuration Setting	GUARD	Guarded Access Menu
CFH	Condenser Fan High Speed	H1TYP	User Hourmeter 1 Type
CFH 1	Condenser Fan High Speed Phase 1 Amps	H2TYP	User Hourmeter 2 Type
CFH 2	Condenser Fan High Speed Phase 2 Amps	H3TYP	User Hourmeter 3 Type
CFH 3	Condenser Fan High Speed Phase 3 Amps	H4TYP	User Hourmeter 4 Type
CHRM1	Compressor 1 On Hours	HEAT	Heat
CHS1	Compressor 1 Head Temperature	HEATR	Heater
CID	Container Identification Number	HERTZ	Hertz
CIDXX	Container Identification Character 01, 02, 03 ...11 (total number of characters)	HOUR	Current Time in Hours
CLEAR	Clear	HTR	Heater
CLKV	Real Time Clock (Lithium) Battery Voltage	HTR 1	Heater Phase I Amps
CNFIG	Configuration	HTR 2	Heater Phase 2 Amps
CNTRL	Controller Test Submenu	HTR 3	Heater Phase 3 Amps
COOL	Cool	HUMID	Humidify/Dehumidify Enable
CPH	Compressor High Speed	HUMSP	Humidity Setpoint
DAY	Current Date Day	INVAL	Invalid
DEHUM	Dehumidify Mode	LIV	Liquid Injection Valve
DFRST	Defrost	LLS	Liquid Line Solenoid Valve
DISPL	Display	LOAD	Load
DMTCH	Defrost Maximum Time in Chill Mode	MC 50	Modulated Cool Mode, 50 Percent Modulation
DMTFZ	Defrost Maximum Time in Frozen Mode	MCIOO	Modulated Cool Mode, 100 Percent Modulation
ECOIL	Evaporator Coil Temperature Sensor	MENU	Menu
ECON	Economy Mode Enable	MIN	Current Time in Minutes
ECONT	Economy Mode Timer	MONTH	Current Month
ECOOOL	Extended Cool	NULL	Null Mode
ECMAX	Economy Mode Maximum (High Switch Point) Setting	ONHRM	Unit On Hours
ECMIN	Economy Mode Minimum (Low Switch Point) Setting	PAUSE	Pause Mode
ECTG	Evaporator Coil Sensor Grade	PCCAP	KVQ Valve Status in Percent
EFH	Evaporator Fan High Speed	PCHUM	Percent Humidity
EFH 1	Evaporator Fan High Speed Phase 1 Amps	PCVAL	Modulation Valve Status in Percent
EFH 2	Evaporator Fan High Speed Phase 2 Amps	PRGRM	Program Menu
EFH 3	Evaporator Fan High Speed Phase 3 Amps	PS 1	Phase Select Contactor 1 (ABC)
EFL	Evaporator Fan Low Speed	PS 2	Phase Select Contactor 2 (CBA)
EFL 1	Evaporator Fan Low Speed Phase 1 Amps	PTI	Pretrip Inspection
EFL 2	Evaporator Fan Low Speed Phase 2 Amps	PTRIP	Pretrip Menu
EFL 3	Evaporator Fan Low Speed Phase 3 Amps	PULP	Pulp Sensor Logging Enable
ELECT	Electrical Test Submenu	PULP1	Pump Temperature Sensor
ENTER	Enter	PWRED	Power Reduction Mode Setting and Enable
ETEST	Extended Pretrip Test	RCOMP	Remote Cool Indicator
EX CH	Extended Chill Mode Pretrip Test	RDEF	Remote Defrost Indicator
		REFRG	Refrigeration Test Submenu
		RET	Return Air Temperature Sensor

RETG	Return Air Sensor Grade
RIR	Remote In-range Indicator
RSP	Remote Spare Indicator
SENSR	Sensor
SETPT	Setpoint Temperature
SLS	Suction Line Solenoid Valve
SOT	Start of Trip
SPR1	Spare Temperature Sensor 1
SPR1G	Spare Sensor 1 Grade
SPR2	Spare Temperature Sensor 2
SPR2G	Spare Sensor 2 Grade
SPR3	Spare Temperature Sensor 3
SPR3G	Spare Sensor 3 Grade
SPR4	Spare Temperature Sensor 4
SPR4G	Spare Sensor 4 Grade
SPR5	Spare Temperature Sensor 5
SPR5G	Spare Sensor 5 Grade
STEST	Single Pretrip Test Submenu
SUP	Supply (Discharge) Air Temperature Sensor
SUPG	Supply Air Sensor Grade
TD	Temperature Differential
TEMP	Temperature
TEST	Test Menu
TIME	Current Time 1
UHMT1	User Hourmeter 1 Threshold
UHMT2	User Hourmeter 2 Threshold
UHMT3	User Hourmeter 3 Threshold
UHMT4	User Hourmeter 4 Threshold
UHRM1	User Hourmeter 1 Hours
UHRM2	User Hourmeter 2 Hours
UHRM3	User Hourmeter 3 Hours
UHRM4	User Hourmeter 4 Hours
UNIT	Unit
USDA	USDA Logging Enable
USDA1	USDA1 Temperature Sensor 1 (USDA Enabled)
USDA2	USDA2 Temperature Sensor 2 (USDA Enabled)
USDA3	USDA3 Temperature Sensor 3 (USDA Enabled)
USN	Unit Serial Number
USNXX	Unit Serial Number Character 01, 02, 03 ...10 (total number of characters)
VERSN	Software Version
VIEW	View Menu
VOLTS	Total Voltage
YEAR	Current Year

Status Indicator LEDs and Alarm Codes

The indicator LEDs stay ON continuously to indicate a unit operating mode or condition. The Alarm LED stays ON continuously when a Check Alarm occurs. The Alarm LED flashes ON and OFF when a Shutdown Alarm occurs. LEDs are located on the µP-D controller and signal the following:

- Cool Mode
- Modulation Mode
- Null Mode
- Heat Mode
- In-Range (Temperature)
- Defrost Mode
- Supply (Air Temperature)
- Return (Air Temperature)
- Power Limit Mode
- Alarm

Alarm Codes

Check Alarms indicate corrective action should be taken before a problem becomes severe. The unit continues to operate. However, some unit functions may be inhibited.

Shutdown Alarms indicate the unit operation has been stopped to prevent damage to the unit or cargo. The problem must be corrected and the alarm code cleared from the controller display before the unit can be restarted to resume normal operation.

Alarm codes are recorded in the controller memory to simplify unit diagnosis and troubleshooting procedures. The first 16 fault codes including the most recent fault code are retained by the controller in a non-volatile memory in order of their occurrence (see codes, alarm type and alarm description below). Alarm codes that are recorded during an automatic Pretrip Test are recorded in the controller memory and displayed with a hyphen (-) preceding the alarm code. Alarm codes 50 through 58 can only be generated during an automatic Pretrip test (or Fitness test).

Alarm Code	Type	Description
00		No Fault
02	Check	Ambient Temperature Sensor Failure
03	Check	Supply Air Temperature Sensor Failure
04	Check	Evaporator Pressure Regulator (KVQ) Valve Thermistor Failure
05	Check	Evaporator Coil Temperature Sensor Failure
06	Check	Humidity Sensor Error
07	Check	Return Air Temperature Sensor Failure
09	Shutdown	Evaporator Coil Over Temperature
10	Check	High Pressure Cutout
12	Check	Temperature Out-of-Range High
13	Check	Temperature Out-of-Range Low
14	Check	Defrost Terminated on Time Limit
16	Shutdown	Digital Input Failure
25	Check/ Shutdown	Return & Supply Temperature Sensor Failure
37	Shutdown	Low Refrigerant Level (Option)
38	Check	Real Time Clock Battery Failure
41	Check	Spare Sensor 5 Failure (Option)
42	Check	Customer Configuration Alarm
43	Shutdown	Frequency Out-of-Range Low
44	Shutdown	Three Phase Current Imbalance
45	Shutdown	Frequency Out-of-Range High
46	Check	USDA Sensor 1 Failure (Option)
47	Check	USDA Sensor 2 Failure (Option)
48	Check	USDA Sensor 3 Failure (Option)
49	Check	Pulp Sensor Failure (Option)
50	Check/ Shutdown	Compressor Current Out-of-Range (Pretrip)
51	Check/ Shutdown	Unit Current Out-of-Range in Cool Mode (Pretrip)
52	Check/ Shutdown	KVQ Valve System Failure (Pretrip)
53	Check/ Shutdown	Heating Current Out-of-Range (Pretrip)
54	Check/ Shutdown	Defrost Current Out-of-Range (Pretrip)
55	Check/ Shutdown	High Speed Evaporator Fan Failure (Pretrip)
56	Check/ Shutdown	Low Speed Evaporator Fan Failure (Pretrip)
57	Check/ Shutdown	Condenser Fan Current Out-of-Range (Pretrip)
58	Check/ Shutdown	Sensor Calibration Failure (Pretrip)
59	Check	Datalogger Full (µP-A+)
60	Check	Datalogger Full (Global)
61	Check	Real Time Clock Invalid
63	Check	Bypass Valve Circuit Failure (Pretrip)
64	Check	Pretrip Preconditioning Failure
65	Check	Datalog Queuing Error
69	Check	Dehumidify Valve Circuit Failure (Pretrip) (Option)
70	Check	Hourmeter Alarm
71	Check	User Hourmeter 1 Expired
72	Check	User Hourmeter 2 Expired
73	Check	User Hourmeter 3 Expired
74	Check	User Hourmeter 4 Expired
79	Check	Datalogger Overflow
81	Check	Compressor Head Temperature Sensor Failure
82	Check	Compressor Head Over Temperature
85	Check/ Shutdown	Compressor Current Out-of-range
92	Check	Condenser Fan Sensor Failure
97	Shutdown	Loss of Communications with Output Module

Pause Alarms

A Pause Alarm (“PAUSE ALMXX”) stops unit operation due to a shutdown alarm condition. A 2-digit alarm code (“XX”) appears in Pause display to identify the alarm condition. Typically the condenser fan continues to operate while the controller attempts to correct the condition and restart the unit. “PAUSE ALMXX” appears in the display for 1 second every 10 seconds until the condition has been corrected. The following Alarm Codes generate a Pause Alarm display:

- 10, High Pressure Cutout
- 43, Frequency Out-of-Range, Low (low supply voltage)
- 82, Compressor Head Over Temperature

NOTE: “PAUSE ALM43” will also appear in the controller display when the Setpoint Enable function is activated to download the controller data logger or change the setpoint.

“PAUSE ALM10”, High Pressure Cutout

The controller immediately stops the compressor and evaporator fans when the high pressure cutout switch opens. The condenser fan and phase select outputs remain energized as the

controller operates the condenser fan for 5 minutes to correct the condition. After 5 minutes, the controller attempts to restart the compressor. If the compressor fails to start due to high pressure cutout, alarm code 10 is generated. The controller will restart the compressor when the fault condition corrects itself (high pressure switch closes).

The controller also generates alarm code 10 if the high pressure cutout/restart cycle repeats 3 times within 30 minutes.

“PAUSE ALM43”, Frequency Out-of-Range Low

The controller immediately stops the compressor, evaporator fans, condenser fan and heaters when a low supply power voltage condition exists. The controller will restart the unit to resume normal temperature control operation when the supply voltage returns to normal.

“PAUSE ALM82”, Compressor Head Over Temperature

The controller immediately stops the compressor and evaporator fans when the discharge gas temperature rises above 148 C (298 F). The condenser fan and phase select outputs remain energized as the controller operates the condenser fan for 5 minutes to correct the condition. After 5 minutes, the controller attempts to restart the compressor. If the compressor still fails to start due to compressor head over temperature, fault code 82 is generated. The controller will restart the compressor when the fault condition corrects itself (resets).

The controller also generates alarm code 82 if the compressor head over temperature cutout/restart cycle repeats 3 times within 30 minutes.

Data Logging and Downloading Data

The μP-D controller can record sensor temperatures as well as loss of power, alarms, unit operating modes, sensor failure, setpoint change and unit shutdown indications. Logging intervals are selectable from 30 minutes and 1 hour. When a 1 hour logging interval is selected, the datalogger memory can store approximately 365 days of information.

PC-PAC software downloads and reports the Return, Supply, Ambient and USDA sensor temperatures as standard. Connect a portable computer with PC-PAC software to the communications port on the control box to download trip data.

Trip data can be retrieved (but not erased) from the controller memory using PC-PAC software. Trip data from separate units is denoted by the identification information entered into the controller at the beginning of the trip by PC-PAC software. Identification data may include the date, container ID number, operator identification, point of origin, product, setpoint and other information up to a total of 80 characters (numerals or alphabetical letters). The container ID number is always resident in the controller memory.

General Theory Of Operation

The μP-D controller uses advanced solid-state integrated circuits to monitor and control all unit functions. The controller monitors inputs from:

- Return air sensor
- Supply air sensor
- Evaporator coil sensor
- Condenser coil sensor
- Ambient sensor
- USDA (Spare) sensors 1, 2 and 3 (option)
- Pulp sensor (or USDA 4 sensor) (option)
- Humidity sensor (option)
- Compressor discharge temperature sensor
- High pressure cutout switch
- Condenser fan pressure switch
- Water pressure switch (water-cooled condenser option)
- Current transformer circuits 1, 2 and 3

Output signals from the controller automatically regulate all unit functions including:

- Compressor operation
- Condenser fan operation
- Evaporator fan motor speed and operation
- Evaporator pressure regulator (KVQ) valve
- Compressor liquid injection valve
- Liquid line solenoid valve
- Dehumidify valve (option)
- Electric heaters
- Bridge light relays for defrost, cool and in-range lights (option)
- Phase selection contactors ABC and CBA

Chill Loads (Setpoint at -9.9 C [14.1 F] and Above)

At setpoints of -9.9 C (14.1 F) and above, the controller uses a proportional-integral derivative capacity control system during cooling. The system uses a direct acting evaporator pressure regulator (KVQ) valve to provide accurate control of the container temperature in direct response to load demand.

The KVQ valve is installed in the suction line and controls the amount of refrigerant returning to the compressor. The KVQ valve opens and closes in response to a controller voltage pulse signal. The controller generates the voltage pulse signal based on a calculated temperature differential. The controller calculates the control temperature differential based on the setpoint temperature; supply air sensor temperature; modulation temperature range and the pull-down rate.

If the supply air sensor fails, the temperature of the return air sensor minus 1.4 C (2.5 F) is used for temperature control. If both sensors fail, the controller will immediately shut down unit operation (chill load operation only).

Frozen Loads (Setpoint at -10 C [14 F] and Below)

At setpoints of -10 C (14 F) and below, the controller controls unit operation based on the return air sensor temperature and setpoint temperature.

The system operates on Full Cool to provide accurate control of frozen cargo. If the return air sensor becomes disconnected or fails while it is being used to control unit operation, the controller will automatically switch and control unit operation from the supply air sensor plus 4.4 C (7.9 F). If both the supply and return air sensors fails, the controller will operate the unit continuously on Cool (frozen load operation only).

Automatic Phase Selection

The μP-D controller monitors each phase of the power supply to ensure proper rotation of the condenser and evaporator fans, and the compressor. During unit start-up, "PAUSE CHECK" appears in the controller display while the controller determines the correct phase sequence. The controller energizes phase select contactor ABC and then the electric heaters, condenser fan and evaporator fans. The controller senses the incoming power phase for 10 seconds and then de-energizes phase select contactor ABC. 30 seconds later, phase select contactor CBA is energized with the selectric heaters, condenser fan and evaporator fans. The controller senses the incoming power phase for another 10 seconds to select the correct phase sequence. The controller then de-energizes all unit loads and energizes either the ABC or CBA phase select contactor to assure correct compressor, condenser fan and evaporator fan rotation.

Compressor Soft Start Sequence

The controller performs a compressor soft start sequence when the compressor has been OFF for more than 8 hours, or the unit has been on heat or defrost. A compressor sequence start cycles the compressor ON 3 seconds, OFF 3 seconds, ON 3 seconds, OFF 3 seconds, ON 3 seconds, OFF 3 seconds and then ON continuously.

Compressor Liquid Injection

During Chill mode operation, a liquid injection system injects refrigerant into the suction line to protect the compressor for excessively high operating temperatures. The controller activates liquid injection when the:

- Compressor discharge temperature exceeds 138 C (280 F).
Liquid injection stops when the compressor discharge temperature decreases to 132 C (270 F).

When liquid injection is active, the controller energizes the liquid injection valve continuously. The liquid injection line injects refrigerant into the suction line between the KVQ valve and the compressor suction service valve.

KVQ Setting (PCCAP)

KVQ valve controls refrigerant return to the compressor during Modulation Cool. The KVQ setting is displayed in the View menu under PCCAP. The PCCAP reading indicates the percent capacity: 100 = 100% of unit capacity; 33 = 33% of unit capacity.

Evaporator Fan Control

The controller determines evaporator fan motor speed based on the return air temperature and the Economy mode setting.

- Evaporator fans operate on HIGH speed at return air temperatures of -9.9 C (14.1 F) and above. If the Economy mode is ON and temperature is In-range, the controller shifts the evaporator fans to LOW speed.
- Evaporator fans operate on LOW speed at return air temperatures of -10 C (14 F) and below. If the Economy mode is ON and the unit is in the Null mode, the controller STOPS the evaporator fans. The controller then operates the evaporator fans on LOW speed for 5 minutes every 45 minutes as long as the unit remains in the Null mode.

Condenser Fan Control

The controller also uses a condenser fan pressure switch to control the condenser temperature and ensure a constant liquid pressure at the expansion valve.

- Condenser fan is ON when the condenser head pressure is above 1380 +/- 50 kPa, 13.80 +/- 0.5 bar, 200 +/- 7 psig (switch open).
- Condenser fan is OFF when the condenser head pressure decreases to 1100 +/- 50 kPa, 11.00 +/- 0.5 bar, 160 +/- 7 psig (switch closed).

NOTE: When unit configurations 5015 or 5016 are loaded (CRR-40-52 units), the controller cycles the condenser fan between ON and OFF based the compressor discharge temperature and/or the condenser coil temperature. The controller uses a control algorithm to monitor these temperature sensors and their rate of temperature change. Therefore, it is impossible to determine exactly when the condenser fan will start and stop. However, the condenser fan will typically be ON when the compressor temperature is above 50 C (122 F) and increasing, or when the condenser temperature is above 35 C (95F).

The condenser fan operates continuously if either the compressor or condenser temperature sensor is defective.

Sensor Check

NOTE: If a Sensor Check occurs, check the supply air sensor position in the probe holder. The supply air sensor MUST be inserted all the way to the bottom of the probe holder to accurately record the supply air temperature.

During unit operation, the controller constantly monitors the supply and return air temperatures. If the temperature difference is outside certain limits during cooling and no alarms are recorded, the controller performs a Sensor Check test.

“SENSR CHECK” appears in the display as the controller turns all loads off except the phase contactor. “SENSR XXX” appears in the display while the controller energizes the high speed evaporator fan output for 5 minutes and compares the supply and return air sensor. If the temperature difference between the supply and return air sensor is greater than 2.2 C (3.9 F), the controller places the unit in defrost and resets the “SENSR XXX” display counter. When defrost is complete, the controller repeats the sensor check test.

- If the temperature difference between the supply and return air sensor is less than 2.2 C (3.9 F), the controller resumes normal operation.
- If the temperature difference between the supply and return air sensor is greater than 2.2 C (3.9 F) and a defrost has occurred in the last 30 minutes, the controller attempts to identify the defective sensor. The controller compares the supply and return air sensor temperatures to the coil sensor temperature:
 - The controller chooses the sensor with the greatest temperature difference with the coil sensor as the defective sensor, records an alarm code and takes appropriate action.
 - If the Return Air sensor is defective and the setpoint is -9.9 C (14.1 F) or above, the controller records alarm code 7 and resumes normal operation.
 - If the Supply Air sensor is defective and the setpoint is -9.9 C (14.1 F) or above, the controller records alarm code 3 and uses the return air sensor temperature plus an offset to control unit operation.
 - If the Return Air sensor is defective and the setpoint is -10.0 C (14.0 F) or below, the controller records alarm code 7 and uses the supply air sensor temperature plus an offset to control unit operation.
 - If the Supply Air sensor is defective and the setpoint is -10.0 C (14.0 F) or below, the controller records alarm code 3 and resumes normal operation.

- If the temperature difference between both the supply and return air sensors and the coil sensor is greater than 2.2 C (3.9 F), the controller determines both sensors are defective, records alarm code 25 and takes appropriate action:

- If the setpoint is -9.9 C (14.1 F) or above, a unit shutdown occurs.
- If the setpoint is -10.0 C (14.0 F) or below, the unit continues to operate on Cool.

Power Limit

The controller also uses current transformers to measure line voltage as well as unit and component amperage draw.

The controller uses total unit current draw information to provide power limit control. When the current exceeds a predetermined threshold, the controller limits unit power consumption by sending a voltage pulse to the KVQ valve. The KVQ valve closes to restrict the flow of refrigerant to the compressor to limit the compressor drive motor current draw to the pre-selected threshold.

Initial Unit Start-up

Power Limit is active during the compressor start-up in both the Chill and Frozen modes, the controller partially closes the KVQ valve to reduce the cooling capacity load on the compressor. The initial power limit position of the KVQ valve is a function of the return air temperature and ambient temperature. If the power limit KVQ valve setting is lower than the modulation cool KVQ valve setting, the Power Limit LED turns ON.

Pull-down and Normal Operation

The KVQ valve then gradually opens to increase cooling capacity during initial pull-down. The controller then uses the total unit current draw and the condenser coil temperature to calculate the power limit KVQ valve setting in both the Chill and Frozen modes. If the power limit KVQ valve setting is lower than the modulation cool KVQ valve setting, the Power Limit LED turns ON. The controller then sends a voltage pulse to the KVQ valve. The KVQ valve closes to restrict the flow of refrigerant to the compressor, thereby limiting the compressor motor current draw to the predetermined setting.

Power Limit Management

A predetermined Power Limit can also be set from “PWRED” feature in the Program Menu of the controller. A 10%, 20% or 30% power reduction can be selected for 8 hours of unit operation. Because the cooling capacity of the unit may be reduced when the Power Reduction Mode is active, use of the Power Reduction Mode should be established by the shipper.

Economy Mode Operation

The Economy Mode reduces unit power consumption by reducing evaporator fan operation on both fresh and frozen loads. The use of the Economy Mode should be established by the shipper and the type of cargo. The Economy Mode option is turned on from Setpoint menu of the controller.

NOTE: If the Economy Mode is set to ON, the controller display will show “ECON ON” for 1 second every 10 seconds.

- Fresh Loads (return air temperatures of -9.9 C (14.1 F) and above): Evaporator fans operate on low speed whenever the container temperature is In-range.
- Frozen Loads (return air temperatures of -10 C (14 F) and below): The evaporator fans stop during the Null mode. A null state timer automatically re-starts the evaporator fans on low speed for 5 minutes every 45 minutes.

The Economy Mode also modifies the temperature control algorithm on frozen loads to extend the Null mode. The unit continues on Cool operation until return air temperature reaches ECMIN temperature. Default ECMIN setting is 2.0 C (3.6 F) below setpoint. ECMIN temperature is adjustable from 0 to 5 C (0 to 8.9 F) below setpoint through the Configuration menu of the controller.

The unit remains in Null until the return air temperature increases to ECMAX temperature at the expiration of a 45 minute Null state time sequence. Default ECMAX setting is .2 C (0.4 F) above setpoint. ECMAX setting is adjustable from 0 to 5 C (0 to 8.9 F) above setpoint through the Configuration menu of the controller.

NOTE: On Frozen loads, supply and return air temperatures may vary considerably during Economy mode operation due to long periods of no air circulation. On Chill loads, container air temperatures may vary 1 C to 3 C (1.8 F to 5.4 F) above setpoint in high ambient temperatures.

Sequence Of Operation

Unit Start-up

A sequence start of the required loads occurs during initial start-up of the controller. If cooling (or heating) is required, the unit operates in the cool (or heat) mode until the controlling sensor reaches setpoint.

- When the unit On/Off switch is turned ON, the Status Indicator LEDs and display turn On and then Off.
- “Phase Check” appears in the controller display while the controller determines the correct phase sequence. Phase selection takes 50 to 80 seconds; or more on extremely noisy power lines. The controller then energizes phase select contactor ABC or CBA.
- The setpoint and controlling air sensor temperature are displayed.
- The evaporator fan motors start. Evaporator fans operate on high speed at return air temperatures of -9.9 C (14.1 F) and above (except when Economy mode is ON and temperature is In-range). Evaporator fans operate on low speed at return air temperatures of -10 C (14 F) and below (except during Null with Economy mode ON).
- The condenser fan motor also starts if the condenser fan pressure switch is open (pressure above 1380 +/- 50 kPa, 13.80 +/- 0.5 bar, 200 +/- 7 psig) and the controller calls for cooling.
- If the controller calls for cooling, the compressor motor starts and the liquid line solenoid valve opens (energizes). If the unit starts in Modulation Cool, compressor start-up can be delayed up to 3 minutes while the evaporator pressure regulator (KVQ) valve opens or closes to the required setting. Unit operates in cool and modulation cool until the controlling sensor reaches setpoint.
- If the controller calls for heating, the electric heaters are energized. Unit operates in heat until the controlling sensor reaches setpoint.
- Power limit is active when the unit is operating in the Cool mode. This means the KVQ valve may be energized to reduce the cooling load on the compressor, thereby reducing total unit power consumption.
- Controller turns ON the In-range LED when the controlling sensor temperature is within 1.7 C (3.0 F) of setpoint.

Operating Mode Function Chart — Standard Operation

Chill Loads Setpoints at -9.9 C (14.4 F) and Above					Frozen Loads Setpoints at -10.0 C (14.0 F) and Below			Unit Function
Cool	Mod	Null	Heat	Defr	Cool	Null	Defr	
•	•	•	•					Evaporator Fans HIGH SPEED ¹
					•	•		Evaporator Fans LOW SPEED ¹
				•			•	Evaporator Fans OFF ¹
•	•	•	•					Proportional-integral Derivative (Supply Air) Control
					•	•		Return Air Sensor Control
				•			•	Evaporator Coil Sensor Control
•	•				•			Compressor ON ²
•	•				•			Liquid Line Solenoid Valve OPEN (energized)
•	•	•			•	•		Condenser Fan ON ³
•					•			KVQ Valve OPEN (valve de-energized) ⁴
•	•				•			KVQ Valve MODULATING (valve energized) ⁴
			•	•			•	Electric Heaters ON (energized)

¹Return air temperature determines the evaporator fan speed (except when Economy Mode is ON):

- At return air temperatures of -9.9 C (14.4 F) and above, the evaporator fans operate on high speed.
- At return air temperatures of -10.0 C (14.0 F) and below, the evaporator fans operate on low speed.

²Null Mode: • On Chill Loads, the compressor stays ON for 60 seconds to pump down the low side.

- On Frozen Loads, the compressor stays ON for 30 seconds to pump down the low side.

³Condenser fan is ON when the condenser pressure is above 1380 +/- 50 kPa, 13.80 +/- 0.5 bar, 200 +/- 7 psig.

- Null Mode: If the condenser fan was ON when the unit shifted to NULL, it will operate for 30 seconds and stop.
- Water-cooled Condenser Option: When water supply pressure opens the water pressure switch, the controller stops the condenser fan.
- Controller set to unit configurations 5015 or 5016 (CRR-40-52 units): The controller uses the compressor and/or condenser temperature to cycle the condenser fan between ON and OFF.

⁴KVQ valve MODULATES:

- When the Power Limit mode is ON.
- When the calculated temperature differential is less than 10 C (17.9 F) above setpoint.

NOTE: Controller OPENS (energizes) the liquid injection valve when the compressor is ON only if the compressor discharge temperature exceeds 138 C (280 F).

Continuous Temperature Control Operation

Chill Loads — Controller Setpoint at -9.9 C (14.1 F) and Above

After the unit reaches setpoint on initial start-up operation, the controller regulates the compressor, KVQ valve and electric heaters based on a CALCULATED TEMPERATURE DIFFERENTIAL (see “General Theory of Operation” in this chapter for more detail). This means the unit operating mode can NOT be predicted based ONLY on the setpoint and supply air sensor temperatures. The controller operates the unit on:

- Cool mode
- Modulation Cool mode
- Null mode
- Heat mode
- Defrost mode
- Evaporator fans operate on high speed (except when Economy mode is ON and temperature is In-range) and continuously circulate air inside the container (except during defrost).

- Controller display shows the setpoint and supply air sensor temperatures.
- Controller uses the condenser fan pressure switch input to cycle a single-speed condenser fan between ON (switch open) and OFF (switch closed). The controller uses the compressor discharge and condenser coil temperatures to cycle the condenser fan ON and OFF on unit with customer configurations 5015 or 5016 loaded (CRR-40-52 units).

Cool

- Controller calls for the Cool mode whenever the Calculated Temperature Differential is more than 10.0 C (17.9 F) above setpoint.
- KVQ valve is fully open so the unit provides maximum cooling capacity.
- Power limit is active when the unit is operating in the Cool mode.

Operating Mode Function Chart — Optional Feature Operation

Chill Loads Setpoints at -9.9 C (14.4 F) and Above					Frozen Loads Setpoints at -10.0 C (14.0 F) and Below			Unit Function
Cool	Mod	Null	Heat	Defr	Cool	Null	Defr	
								Economy Mode ON: Evaporator Fans HIGH SPEED ¹
•	•	•	•		•			Economy Mode ON: Evaporator Fans LOW SPEED ¹
				•		•	•	Economy Mode ON: Evaporator Fans OFF ¹
	•							Dehumidify ON: Dehumidify Valve CLOSED (energized) ²
	•							Dehumidify ON: Electric Heaters ON (energized) ²
•	•	•	•					Humidify ON: Air Compressor ON (energized) ³

¹Economy Mode ON: • On Chill Loads, the evaporator fans operate on low speed when the supply air temperature is In-range.
 • On Frozen Loads, the evaporator fans stop during the Null mode when the return air temperature is In-range. A timer re-starts the evaporator fans on low speed for 5 minutes every 45 minutes. If cooling is required, the evaporator fans operate until the unit returns to Null mode.

²Dehumidification Option: When the Dehumidify Mode is set to ON, the supply air temperature must be in-range to CLOSE (energize) the dehumidify valve:
 • When the humidity is 1 to 5% above setpoint, the controller CLOSES (energizes) the dehumidify valve.
 • When the humidity is more than 5% above setpoint, the controller CLOSES (energizes) the dehumidify valve AND pulses the electric heaters ON and OFF.

³Humidification Option: When the container humidity is more than 2% below the humidity setpoint, the controller operates (energizes) the air compressor to inject atomized water directly into the evaporator supply air stream.

Modulation Cool

- Controller calls for Modulation Cool when the Calculated Temperature Differential is between 10.0 C (17.9 F) above setpoint and setpoint (after initial temperature pull-down).
- Controller opens and closes the KVQ valve to regulate the flow of refrigerant to the compressor. The position of the KVQ valve balances the unit cooling capacity against the actual load requirements.
- Controller turns ON the In-range LED when the controlling sensor temperature is within 1.7 C (3.0 F) of setpoint. The controller keeps the In-range LED ON as long as the supply air temperature remains less than 2.5 C (4.5 F) above setpoint. If the supply air goes out-of-range high, the In-range LED remains OFF until the supply air temperature decreases to 1.7 C (3.0 F) above setpoint.

NOTE: If the supply air sensor temperature goes out-of-range high for 75 minutes after the unit is In-range, the controller will turn ON the Alarm LED. Alarm code 12 (a check alarm) is also recorded in the controller's memory.

Null

- The controller calls for Null when the Calculated Temperature Differential is between setpoint and 0.6 C (1.0 F) below setpoint (on temperature pull-down).
- The controller de-energizes the liquid line solenoid valve to pump down the low side.
- The controller de-energizes the compressor contactor (to terminate pump down) 60 seconds later.
- If the condenser fan was ON, it will operate for 30 seconds and then stop. If the condenser fan was OFF (based on condensing pressure), it will remain OFF.
- The evaporator fans continue to operate.

Heat

- The electric heaters begin to pulse ON and OFF (energized and de-energized) when the Calculated Temperature Differential decreases to 0.6 C (1.0 F) below setpoint (on temperature pulldown). The amount of ON time increases as the Calculated Temperature Differential decreases below setpoint. The electric heaters remain energized continuously (100% of time) when the Calculated Temperature Differential decreases to 3.1 C (5.5 F) below setpoint.

On temperature pull-up (and initial start-up), the controller pulses the electric heaters ON and OFF until the Calculated Temperature Differential increases to setpoint.

- The evaporator fans continue to operate.
- Controller turns OFF the In-range LED when supply air temperature decreases more than 2.5 C (4.5 F) below setpoint. After the supply air temperature goes out-of-range low, the In-range LED remains OFF until the supply air temperature increases to 1.7 C (3.0 F) below setpoint.

NOTE: If the supply air sensor temperature goes out-of-range low for 75 minutes after the unit is In-range, the controller will turn ON the Alarm Light. Alarm code 13 (a check alarm) is also recorded in the controller's memory.

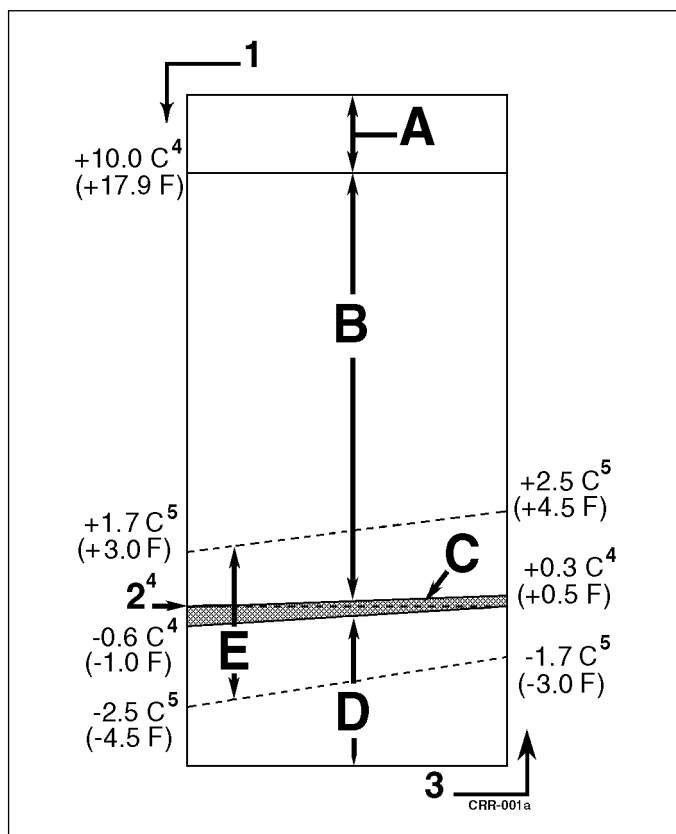

Chill Load Control Sequence (Setpoints at -9.9 C [14.1 F] and Above)

- A. Cool
- B. Modulation Cool
- C. Null
- D. Heat
- E. In-Range
- 1. Decreasing Temperature
- 2. Setpoint
- 3. Increasing Temperature
- 4. Calculated Temperature Differential
- 5. Supply Air Temperature

Frozen Loads — Controller Setpoint at -10 C (14 F) and Below

At setpoints of -10 C (14 F) and below, the controller locks out the Modulation Cool and Heat modes. The controller regulates compressor operation based the return air sensor and setpoint temperatures to determine operating mode switch points.

At setpoints at -10 C (14 F) and below, the controller operates the unit on:

- Cool mode
- Null mode
- Defrost mode
- Evaporator fans operate on low speed (after return air temperature decreases to -10 C [14 F]) and continuously circulate air inside the container (except during defrost; or during Null mode with Economy Mode ON).
- Controller display shows the setpoint and return air sensor temperatures.
- Controller uses the condenser fan pressure switch input to cycle a single-speed condenser fan between ON (switch open) and OFF (switch closed). The controller uses the compressor discharge and condenser coil temperatures to cycle the condenser fan ON and OFF on unit with customer configurations 5015 or 5016 loaded (CRR-40-52 units).

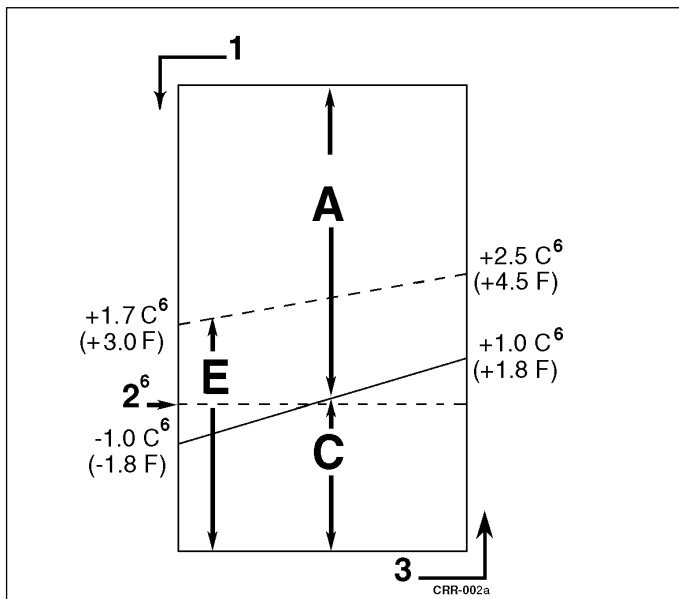

Frozen Load Control Sequence (Setpoints at -10 C [14 F] and Below) — Economy Mode OFF

- A. Cool
- C. Null
- E. In-Range
- 1. Decreasing Temperature
- 2. Setpoint
- 3. Increasing Temperature
- 6. Return Air Temperature

Cool

- Controller calls for the Cool mode whenever the return air temperature is more than 1.0 C (1.8 F) above setpoint.
- Power limit is active when the unit is operating in the Cool mode.
- After the initial temperature pull-down, the In-range LED turns OFF if the return air temperature increases more than 2.5 C (4.5 F) above setpoint. The return air goes must decrease to 1.7 C (3.0 F) above setpoint to turn the In-range LED ON again.

NOTE: If the return air sensor temperature goes out-of-range high for 75 minutes after the unit is In-range, the controller will turn ON the Alarm LED. Alarm code 12 (a check alarm) is also recorded in the controller's memory.

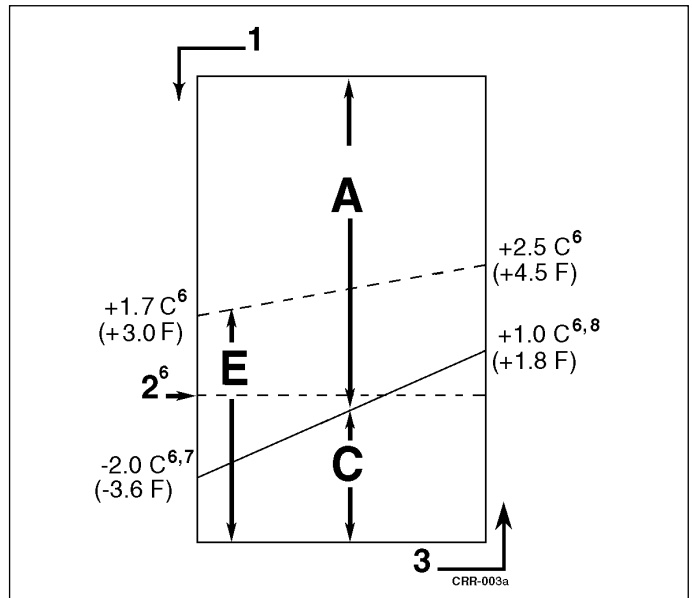

Frozen Load Control Sequence (Setpoints at -10 C [14 F] and Below) — Economy Mode ON

- A. Cool
- C. Null
- E. In-Range
- 1. Decreasing Temperature
- 2. Setpoint
- 3. Increasing Temperature
- 6. Return Air Temperature
- 7. EMIN (default setting is -2.0 C [-3.6 F]). Setting is adjustable from -10 to 0 C (-18 F to 0 F).
- 8. EMAX (default setting is +1.0 C [+1.8 F]). Setting is adjustable from +10 to 0 C (+18 F to 0 F).

Null

- The controller calls for Null when the Return Air Temperature decreases more than 1.0 C (1.8 F) below setpoint (on temperature pull-down).
- The controller de-energizes the liquid line solenoid valve to pump down the low side.
- The controller de-energizes the compressor contactor (to terminate pump down) after 30 seconds.
- If the condenser fan was ON, it will operate for 30 seconds and then stop. If the condenser fan was OFF (based on condensing pressure), it will remain OFF.
- The evaporator fans continue to operate in low speed.

Defrost

During the Cool, Modulation Cool or Null modes, the controller initiates the Defrost mode when the evaporator coil sensor temperature is below 10 C (50 F) and:

- Demand Defrost algorithm determines when defrost is required based on the return air temperature, evaporator coil temperature, condenser coil temperature and the percent modulation.
- Internal Defrost Timer calls for defrost based on a timed defrost interval:

On Chill Loads

- Default: The initial time interval is 3 hours. One (1) hour is added to the time interval each time two timed defrost cycles occur without a demand defrost cycle between them. Maximum accumulated time interval is 8 hours. Time interval resets when the setpoint is adjusted to -10 C (14 F) or below, when the unit is turned OFF for 48 hours, or when a manual defrost occurs.
- Customer Configuration C5: Standard default times but maximum time interval is 6 hours on chill loads.
- Customer Configuration C6: 2 hour initial defrost, then maximum time interval is 6 hours on chill loads.

On Frozen Loads

- Default: The initial time interval is 8 hours. Two (2) hours are added to the time interval each time two timed defrost cycles occur without a demand defrost cycle between them. Maximum accumulated time interval is 24 hours. Time interval resets when the setpoint is adjusted to -9.9 C (14.1 F) or above, when the unit is turned OFF for 48 hours, or when a manual defrost occurs.
- Customer Configuration C5: Standard default times but maximum time interval is 12 hours on frozen loads.
- Customer Configuration C6: 2 hour initial defrost, then maximum time interval is 6 hours on frozen loads.

- A manual defrost is initiated (loaded) using the controller keypad.

NOTE: If unit operating conditions do not allow the unit to enter a defrost cycle, “DFRST INVALID” (defrost invalid) appears on the controller display when a manual defrost is initiated (loaded) via the controller keypad.

NOTE: If the coil sensor fails, the controller substitutes the temperature of the controlling sensor to determine when a defrost mode may initiated.

When the defrost mode is initiated:

- The controller de-energizes the compressor, evaporator fan and condenser fan contactors, and liquid line solenoid valve.
- When the compressor stops, the controller turns ON the Defrost LED and energizes the heater contactor, turning on the electric heaters.

The controller terminates the defrost mode when:

- Chill mode: Evaporator coil sensor temperature reaches 30 C (86 F).
- Frozen mode: Evaporator coil sensor temperature reaches 18 C (64.4 F).
- Time/temperature function: Controller terminates defrost if the evaporator coil sensor rises and remains above 8 C (46 F) for 10 minutes (Frozen mode only).
- Interval timer: Controller terminates defrost 90 minutes after initiation if the coil sensor temperature has not terminated defrost. An alarm code will be generated if this occurs.

NOTE: If the coil sensor fails, the controller substitutes the return air (top) sensor. Defrost is terminated when the top sensor reaches 18 C (64.4 F). If both the coil and top sensor fail, the controller will terminate defrost 60 minutes after initiation. An alarm code will be generated if this occurs.

- When the controller terminates Defrost, the heater contactor is de-energized. The controller starts the compressor and condenser fan (if required) and energizes the liquid line solenoid valve to pre-cool the evaporator coil. The controller energizes the high or low speed evaporator fan contactor (depending on return air temperature) after the evaporator coil has been pre-cooled to minimize heat energy release into the container.

Reviewing Software Version and Configuration

The software version, unit configuration number and customer configuration number are stored in the controller memory. To view the software version and configuration number, turn the unit On/Off switch ON:

1. With the Standard Display showing on the controller (i.e. setpoint and controlling sensor temperature), press and hold the ENTER key for 3 seconds.
 - Display will show the software version for 2 seconds (in following format: VERSN 11.71).

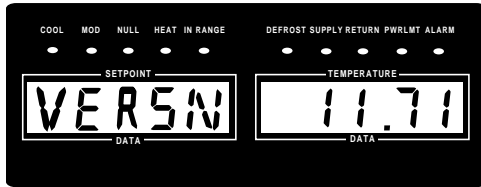

- Display then shows the unit configuration number for 2 seconds (replacement controller default setting: CFG U 5000).

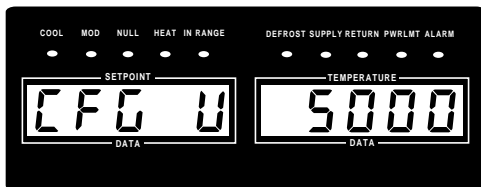

- Display then shows the customer configuration number for 2 seconds (replacement controller default setting: CFG C 0).

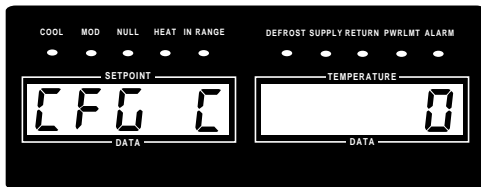

NOTE: The customer configuration **MUST** also always be set to the configuration number shown on the set up decal in the unit control box. Alarm code 42 (unit configuration alarm) is displayed if the customer configuration has not been set to a valid number (other than “0”).

NOTE: The unit will operate and control the container temperature if the controller remains programmed to unit configuration “5000” and customer configuration “0”. However, the unit will not operate customer specific options. See the decal inside the control box for the correct unit configuration and customer configuration settings for the unit. To load new configuration numbers, see MENU GUARD under Menu Operating Instructions in this chapter.

2. The display then returns to the Standard Display.

Displaying Alternate Fahrenheit (F) or Celsius (C) Temperatures

NOTE: The C/F units shown on the controller display can be changed by pressing and holding the C/F key, and then pressing the ENTER key.

The controller can display temperatures in Fahrenheit or Celsius. With the unit On/Off switch ON and the controller showing a Standard Display:

1. Press and hold the F/C key. The controller will show the display temperatures in the alternate temperature scale (Fahrenheit or Celsius) from the temperatures shown on the display as long as the F/C key is depressed.
2. The display then returns to the original display when the F/C key is released.

NOTE: The setpoint temperature can be entered in either F or C using the F/C key. Just press and hold the F/C key (to display the alternate temperature scale).



Displaying Alternate Controlling (Supply or Return) Air Sensor Temperature

The controller can show either the supply air or return air temperature in the right display. With the unit On/Off switch ON and the controller showing the Standard Display:

1. Check the indicator LEDs to determine which sensor temperature (supply air or return air) currently appears in the right display. This is the controlling sensor (supply air sensor at setpoints of -9.9 C [14.1 F] and above; return air sensor at setpoints of -10 C [14 F] and below).
2. To view the alternate air sensor temperature, press and hold the RET/SUP key. The controller will show the temperature of the alternate (non-controlling) air sensor as long as the RET/SUP key is depressed.
3. The display then returns to the Standard Display when the RET/SUP key is released.

NOTE: The setpoint temperature can be entered in either °F or °C using the F/C key. Just press and hold the F/C key (to display the alternate temperature scale). Press the UP or DOWN key to scroll to the correct setpoint temperature. Then press the ENTER key to load the setpoint.

2. When the desired setpoint appears in the right display, press the ENTER key. The right display shows "LOAD".

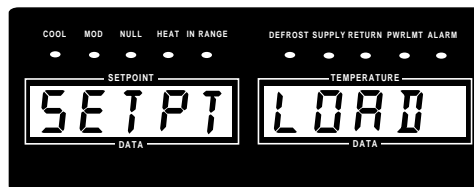

NOTE: If the ENTER key is not pressed within 10 seconds, the controller will default (return) to the previous setpoint. If this occurs, repeat steps 1 and 2.

3. The display then returns to the Standard Display (showing new setpoint).

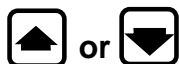
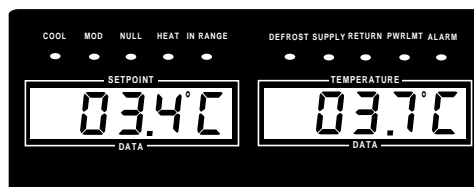

Changing the Setpoint

To change the controller setpoint, turn the unit On/Off switch ON. With the Standard Display showing on the controller (i.e. setpoint and controlling sensor temperature):

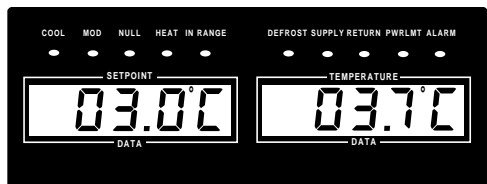

1. Press the DOWN or UP arrow key. The left display flashes "SETPT" while the right display shows the changing setpoint temperature. To set the tenths digit, wait 4 seconds for all three digits to appear on the display. Make additional setpoint adjustment if necessary.

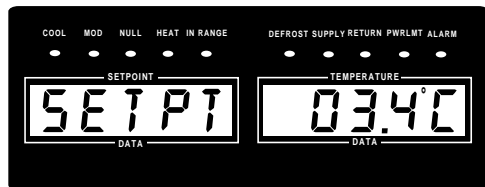



Initiating a Manual Defrost

With the unit On/Off switch ON:

1. Press the DEFROST key. The display flashes “ENTER DFRST”.

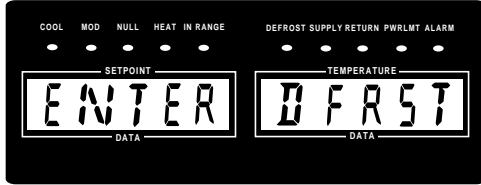

2. Press the ENTER key.
 - If the unit operating conditions allow a manual defrost (e.g. evaporator coil temperature is less than 10 C [50 F]), the display briefly shows “LOAD DFRST”. The unit enters defrost as the Defrost LED turn ON. The defrost cycle automatically terminates.

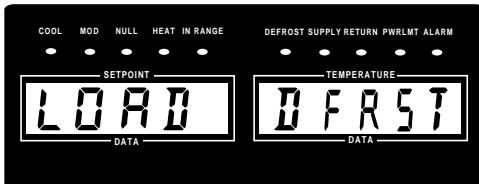

NOTE: If the ENTER key is not pressed within 10 seconds, the controller will default (return) to the Standard Display.

- If unit operating conditions do NOT allow defrost, the display shows “DFRST INVAL” for 3 seconds.

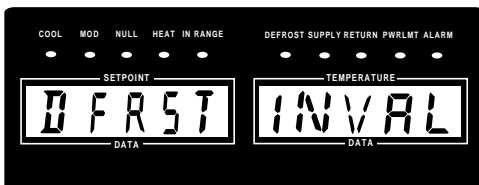

3. The controller then returns to the Standard Display.



Initiating a Full Pretrip

To perform a Full Pretrip test, turn the unit On/Off switch ON:

NOTE: The controller will not perform an automatic pretrip test until all alarms have been corrected and cleared.

1. Press the PRETRIP key. The display flashes “ENTER PTRIP”.

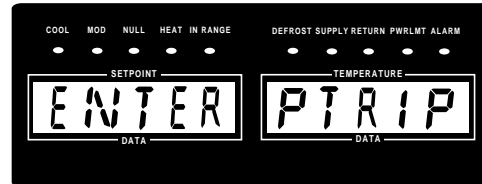

2. Press the ENTER key. The display briefly shows “LOAD PTRIP”. The controller then conducts a Full Pretrip Test.

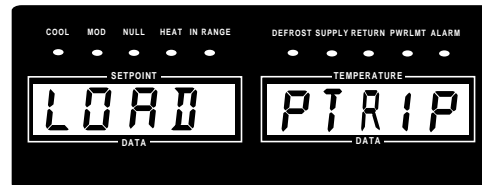

3. When the Pretrip test is complete, the display returns to the Standard Display (e.g. setpoint and controlling sensor temperatures). The unit returns to normal operation.



Entering a Start of Trip Marker

To enter a Start of Trip marker, turn the unit On/Off switch ON or operate the controller using battery power (press the SELECT key):

1. Press the SOT (Start of Trip) key. The display flashes “ENTER SOT”.

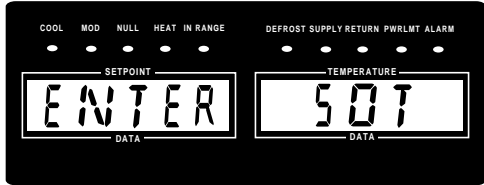

2. Press the ENTER key. The display briefly shows “LOAD SOT”. The controller inserts a SOT marker in the data logger memory.

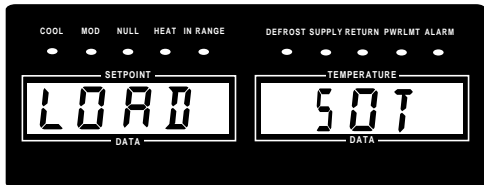

NOTE: If the ENTER key is not pressed within 10 seconds, the controller will default (return) to the Standard Display.

3. The controller then returns to the Standard Display.



Displaying and Clearing Alarm Codes

If the Alarm LED is ON or flashing ON and OFF, use the ALARM key to view the alarm code(s). Turn the unit On/Off switch ON or operate the controller using battery power (press the SELECT key):

1. Press the ALARM key.
 - The left display shows the number of alarms stored in memory (e.g. ALM 2).
 - The right display shows a two digit code for the most recent alarm (e.g. 02).

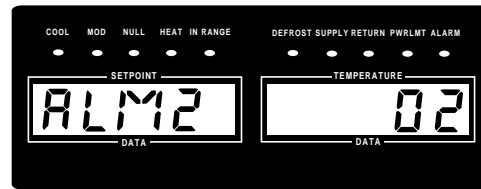

2. Write down the first alarm code. Then press the DOWN key to view the next alarm code.
3. Repeat step 2 until all alarm codes have been recorded.
4. After the last alarm code (ALM 1) has been viewed and recorded, the left display flashes “ENTER” (the code number of the last alarm still appears in the right display).

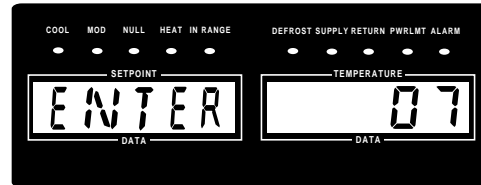

NOTE: Clear the Alarm codes ONLY after the alarm codes are documented and problems repaired. Clearing the codes erases them from the controller Alarm display memory.

NOTE: If the ENTER key is not pressed within 10 seconds, the controller will default (return) to the Standard Display.

5. To clear all alarm codes from the current display memory, press the ENTER key. The display briefly shows “ALARM CLEAR”.

WARNING: Some unit malfunctions will cause an Alarm and unit shutdown condition. When the alarm codes are cleared, the unit will start automatically.

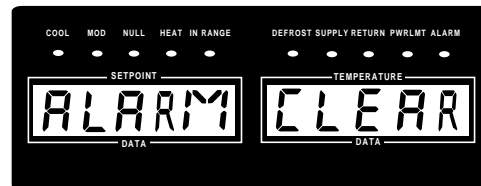

6. The controller then returns to the Standard Display.

Controller Menu Operating Instructions

NOTE: To view the controller’s menu or download data when external power is disconnected from the unit, connect a 12 Vdc battery to the battery jack on the Power Module Board inside the control box. Then press **SELECT** key or connect a communications cable to the Data Port on the bottom of the control box.

NOTE: To return to the controller’s Standard Display from anywhere within the µP-D menu, press the **SELECT** key for 3 seconds.



Navigating the Controller Menu:

The µP-D controller menu is divided into five major menus:

- MENU VIEW
- MENU PTRIP
- MENU TEST
- MENU GUARD
- MENU PRGRM

Moving through these five menus and their submenus and entering commands requires the use of four keys:

 **SELECT** key: Press the **SELECT** each time you want to enter a new menu or submenu; or start a procedure to load a command or value.

 or  **UP** or **DOWN** key: Press the **UP** or **DOWN** key each time you want to scroll up or down to view another item in a menu or submenu.

 **ENTER** key: Press the **ENTER** key to load a command or value.

Menu View Functions

NOTE: Information can **ONLY** be displayed using the View menu. Items can **NOT** be changed. See “MENU PRGRM” in this chapter for information about setting control functions.

The View menu displays general unit operating information including sensor temperatures, component electrical data, etc. The View Menu also includes two submenus, Grade and Log.

Navigating the Menu View Screens

With the unit On/Off switch ON and the controller showing the Standard Display:

1. Press the **SELECT** key to enter menu (display shows “MENU <--->”).

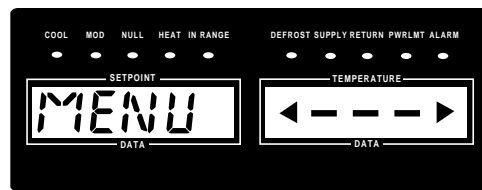

2. Press **DOWN** key until display shows “MENU VIEW”.

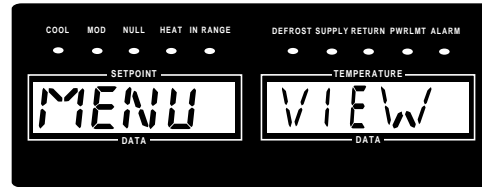

3. Press the **SELECT** key to enter VIEW submenu (display shows “VIEW <--->”).

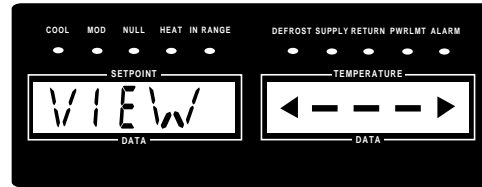

4. Press the **DOWN** key to view functions in submenu. Press the **UP** key to scroll back through submenu. Display shows submenu function and value (e.g. “RET 03.7 C”).

NOTE: To lock the current View Menu screen in the controller display, press the **ENTER** key. A colon flashes in the left display to indicate the screen is locked (the screen remains locked for 15 minutes). Press any key to unlock the display.

NOTE: The controller returns to the Standard Display from a View Menu screen after about 10 seconds, or when the SELECT key is pressed and held for 3 seconds.

GRADE Submenu

The Grade submenu displays the sensor grade of each sensor installed on the unit. With the unit On/Off switch ON and the controller showing the Standard Display:

NOTE: If a sensor grade is set to "0", it means the sensor has been ice bath calibrated. Original unit sensors are ice bath calibrated at the factory. See "Setting the Sensor Grades" in this chapter for more information.

1. Press the SELECT key to enter menu (display shows "MENU <--->").
2. Press DOWN key until display shows "MENU VIEW".
3. Press the SELECT key to enter VIEW submenu (display shows "VIEW <--->").

4. Press the UP key until "VIEW GRADE" shows in the display.
5. Press the SELECT key to enter the Grade submenu. Display will show "GRADE <--->".
6. Press DOWN key to view functions in GRADE submenu. Display shows submenu function and value (e.g. "RETG 5").

NOTE: The controller returns to "GRADE <--->" screen from a sensor grade screen after about 10 seconds. The controller returns to the Standard Display after another 10 seconds, or when the SELECT key is pressed and held for 3 seconds.

LOG Submenu

- The Log submenu provides two scrollback displays:
 - TEMP: Display shows unit operating information recorded with the last 100 data logs.
 - PTI: Display shows "PASS" or "FAIL" and individual test results recorded for the last 4 Full Pretrip tests.

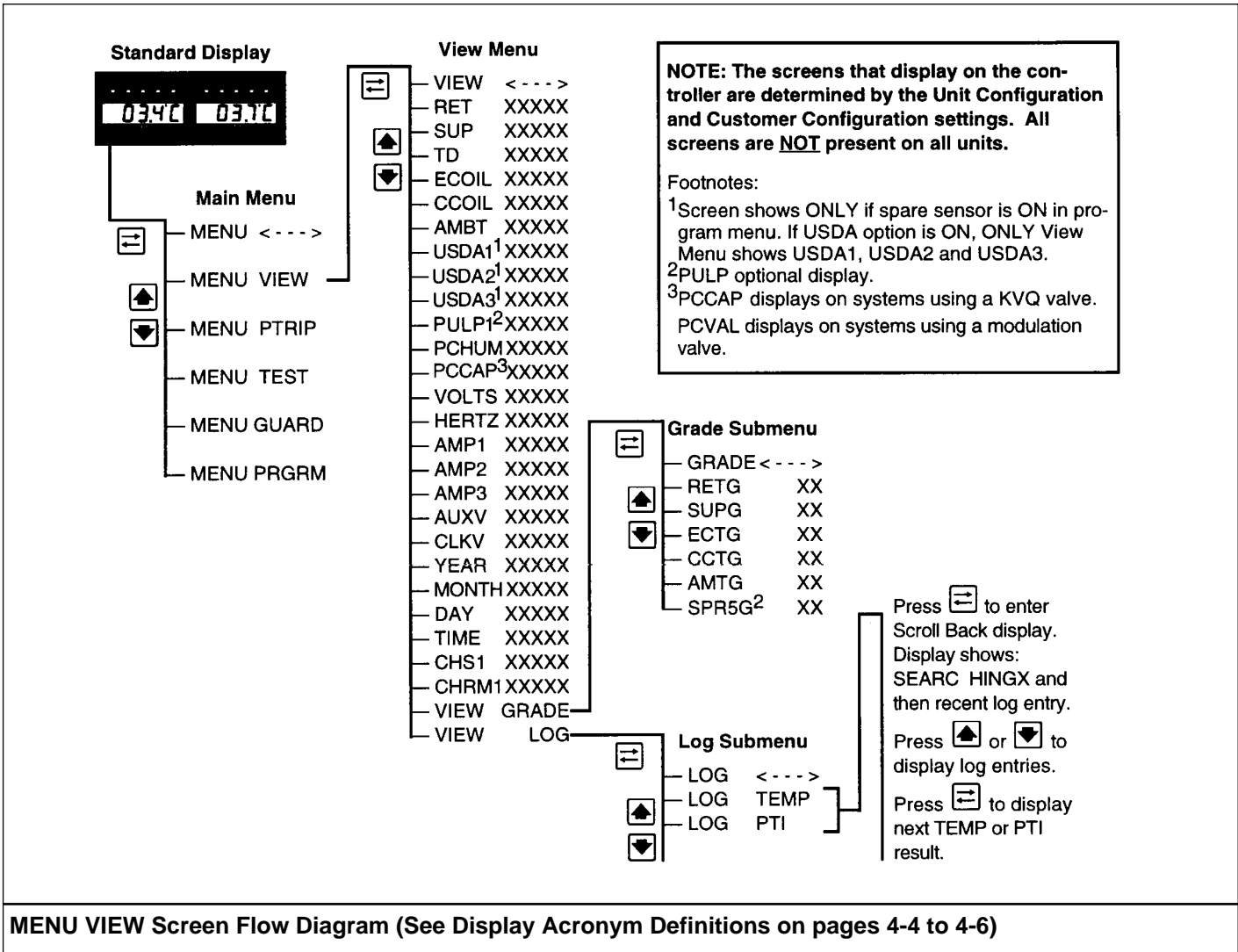

MENU VIEW Screen Flow Diagram (See Display Acronym Definitions on pages 4-4 to 4-6)

When viewing information in the TEMP or PTI scrollback display, the status indicator LEDs on the controller show the unit operating states that were active (ON) when the data or event was recorded. If the Alarm LED is ON, press the ALARM key to view alarm and/or event information in the right display (e.g. "03.204").

If more than one alarm/event is recorded, press the DOWN key to scroll to the next alarm/event code. Alarms are identified by the 2 digits furthest to the right of the decimal point and are always preceded by a "0" (see the Alarm Code list on page 4-7). Events (e.g. Power Up) are identified by a 3 digit number that always begins with a "2".

NOTE; The scrollback alarm/event screen display does NOT identify which alarms are pretrip alarms.

The 3 digit event codes that may appear in the scrollback alarm/event screen display includes:

Event Code	Description
201	Setpoint Change
202	Power Up
203	Power Off
204	Alarm(s) Cleared
205	Real Time Clock Reset
206	Start of Trip (SOT) Entered
207	Text Header Entered
208	Defrost Initiated
209	Defrost Terminated
210	Power Limit Algorithm Active
211	Pretrip Passed
212	Pretrip Failed

With the unit On/Off switch ON and the controller showing the Standard Display:

1. Press the SELECT key to enter menu (display shows "MENU <--->").
2. Press DOWN key until display shows "MENU VIEW".
3. Press the SELECT key to enter VIEW submenu (display shows "VIEW <--->").
4. Press the UP key until "VIEW LOG" shows in the display.
5. Press the SELECT key to enter the Log submenu. Display will show "LOG <--->".
6. Press DOWN key to view scrollback menu items in LOG submenu. Display will show "LOG TEMP" or "LOG PTI".
7. Press the SELECT key to enter either the "LOG TEMP" or "LOG PTI".

TEMP Scrollback Display Items

The TEMP scrollback display contains a lot of information that may appear confusing at first. After entering the TEMP display ("001RT 43.8F" appears in display), imagine that the data is stored in a table. The first column identifies the number of the Log entry (001, 002, etc.) and the return temperature entry. Each additional column identifies information about another sensor or the time of the event.

The TEMP scrollback display shows the following acronyms and information:

- RT Return Air Sensor Temperature
- ST Supply Air Sensor Temperature
- SP Setpoint Temperature
- AT Ambient Sensor Temperature
- U1 Spare 1 (USDA 1) Sensor Temperature
- U2 Spare 2 (USDA 2) Sensor Temperature
- U3 Spare 3 (USDA 3) Sensor Temperature
- HM Humidity (%)
- PP Pulp Probe Sensor Temperature
- YR Year
- MO Month
- DY Day
- TI Time

TEMP (Temperature) Scrollback Information Matrix

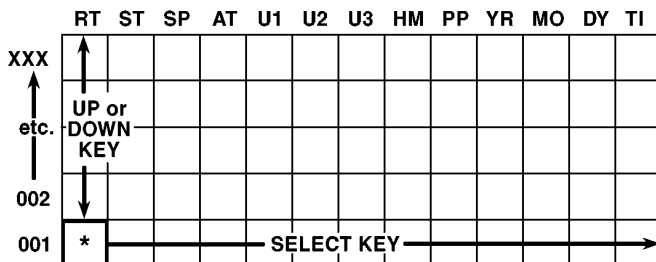

*First information screen displayed from the TEMP Scrollback menu.

PTI (Pretrip) Scrollback Information Matrix

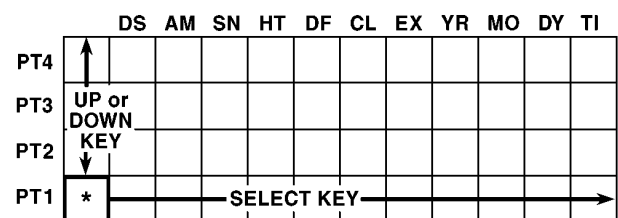

*First information screen displayed from the PTI Scrollback menu.

To enter the TEMP scrollbar submenu:

1. Press the SELECT key with “LOG TEMP” in the display. Display will briefly show “SEARC HINGX”. The display then shows the last (most recent) data log entry (e.g. “001RT 43.8F”).
2. Press Up or DOWN key to scroll (up or down) through the last 100 data log entries of the return air temperature.
3. Press the SELECT key to scroll (to the right) to the next column of data. The display wraps around from T1 (Time) screen to RT (Return Temperature) screen. Press the RET/SUP key to quickly return to the RT (return temperature) display.

NOTE: *If a log entry for a sensor was not recorded, the right display will show “NOLOG”.*

NOTE: *The controller returns to the “LOG TEMP” screen from a data log screen after 10 seconds if no controller key is pressed. The controller returns to the Standard Display after another 10 seconds, or when the SELECT key is pressed and held for 3 seconds.*

PTI Scrollback Display Items

The PTI scrollbar display also contains a lot of information. After entering the PTI display (“PT1 PASS” or “PT1 FAIL” appears), imagine that the data is stored in a table. The first column identifies the number of the Full Pretrip test (PT1, PT2, etc.) and the test result (PASS or FAIL). Each additional column identifies information about an individual test result or the time of the test.

The PTI scrollbar display shows the following acronyms and information:

DS Display Test Result
 AM Amps Test Result
 SN Sensors Test Result
 HT Heat Test Result
 DF Defrost Test Result
 CL Cool Test Result
 EX Extended Cool Test Result
 YR Year
 MO Month
 DY Day
 TI Time

To enter the PTI scrollbar submenu:

1. Press the SELECT key with “LOG PTI” in the display. Display will show the result of the last (most recent) Full Pretrip test (e.g. “PT1 FAIL” or “PT1 PASS”).
2. Press UP key to scroll back through the last 4 Full Pretrip test entries.
3. Press the SELECT key to scroll (to the right) to the next individual test result stored with each Full Pretrip test (e.g. “PT1DS PASS”). Display wraps around the TI (Time) screen to DS (Display Test) screen. Press the RET/SUP key to quickly return to the DS (Display Test) screen.

NOTE: *If a log entry for a sensor was not recorded, the right display will show “NOLOG”.*

NOTE: *The controller returns to the “LOG PTI” screen from a pretrip log screen after 30 seconds. To return to the Standard Display, press and hold the SELECT key for 3 seconds.*

Menu Pretrip Functions

Three pretrip test menus are available through the PTRIP Menu of the controller to test the unit's electrical and refrigeration system components.

1. **Extended Pretrip Test:** Conducts a comprehensive functional check of unit performance (requires up to 7 hours to complete on an empty container). Activate an Extended Pretrip Test (EATEST) from the PTRIP menu. When an extended pretrip test is complete, unit operation stops. The Extended Pretrip Test includes:
 - Full Pretrip Test: Controller performs all of the tests used in the Full Pretrip Test (see details below).
 - Extended Cool Test: Controller operates unit in cooling for an extended period to verify system cooling performance. The extended test pulls the container temperature down to 0 C (32 F) and then -18 C (0 F) in two stages.
2. **Full Pretrip Test:** Conducts a functional check of unit operating modes (requires up to 30 minutes to complete on an empty container). Activate a Full Pretrip Test from the PTRIP menu; or by pressing the PRETRIP key on the controller keypad and then pressing the ENTER key. When a full pretrip test is complete, the unit returns to normal operation. The Full Pretrip Test includes:
 - Display: Controller lights all segments in the display for visual inspection by technician.

- Amps: Controller individually energizes all outputs including fan and compressor motors, and solenoid valves. The controller checks current draw to verify correct operation.
 - Sensors: Controller operates unit to condition all sensors and then verifies correct sensor calibration.
 - Heat Capacity: Controller energizes evaporator fans and electric heaters to verify correct operation.
 - Defrost: Controller energizes electric heaters only to verify correct defrost operation.
 - Cool Capacity: Controller cycles unit through cooling modes (including modulation) and monitors sensor temperatures to verify correct refrigeration system operation.
3. **Single Pretrip Test:** Conducts a functional check of one of the individual operating modes conducted during a Full Pretrip Test. Most tests require 1 to 10 minutes to complete. However, COOL may take up to 30 minutes, SENSR may take up to 45 minutes, and ECOOL may take up to 7 hours. Activate a Single Pretrip Test from the PTRIP menu. When a single pretrip test is complete, the unit returns to normal operation.

NOTE: If a Check Alarm fault occurs during a pretrip test, the Alarm LED turns ON while the controller continues the Pretrip test. If a Shutdown Alarm fault occurs during a Pretest

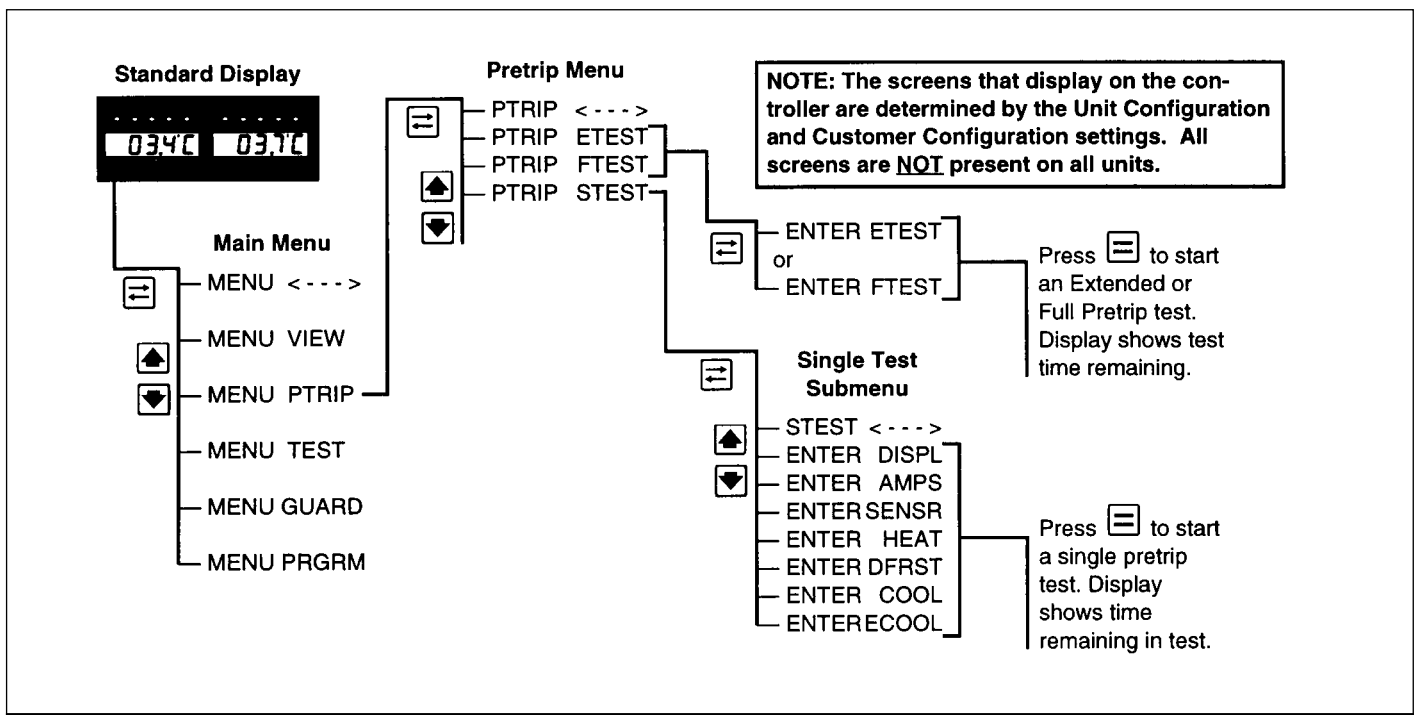

MENU PRETRIP Screen Flow Diagram (See Display Acronym Definitions on pages 4-4 to 4-6)

test, the Alarm LED FLASHES and the controller stops all unit operation. Press the ALARM key to display any fault codes recorded in the controller display memory. All alarms that occur during a pretrip test will have a hyphen (-) in front of the code number.

Performing an Extended, Full or Single Pretrip Test from the Pretrip Menu

To perform an Extended, Full or Single Pretrip Test:

1. Turn the unit On/Off switch ON.

NOTE: The controller will not perform an automatic pretrip test until all alarms have been corrected and cleared.

2. Press the SELECT key to enter menu (display shows "MENU <--->").
3. Press DOWN key until display shows "MENU PTRIP".
4. Press the SELECT key to enter PTRIP menu (display shows "PTRIP <--->").
5. Press the DOWN key to view functions in submenu. Press the UP key to scroll back through submenu. Display shows PTRIP and submenu function (e.g. "PTRIP ETEST").

• To initiate an Extended Pretrip Test:

- a. Press the SELECT key with "PTRIP ETEST" in the display.
- b. Flashing display will show "ENTER PTRIP".
- c. Press the ENTER key. A flashing display will show LOAD PTRIP. The controller then conducts an Extended Pretrip Test.
- d. When the test is complete, the unit shuts down.

• To initiate a Full Pretrip Test:

- a. Press the SELECT key with "PTRIP FTEST" in the display.
- b. Flashing display will show "ENTER PTRIP".
- c. Press the ENTER key. A flashing display will show LOAD PTRIP. The controller then conducts a Full Pretrip Test.
- d. When the test is complete, the unit shuts down.

• To initiate a Single Pretrip Test:

- a. Enter STEST submenu by pressing the DOWN key with "PTRIP STEST" showing in the display. Display will show "STEST <--->".
- b. Press the DOWN key to view a test function in STEST submenu. Flashing display will show ENTER and test function (e.g. "ENTER HEAT").
- c. With test function you want in RIGHT display, press the ENTER key. Left display will show LOAD while the right display shows the test function selected. The controller then conducts the Single Pretrip Test selected.
- d. When the test is complete, the display returns to the Standard Display. The unit returns to normal operation.

NOTE: When a pretrip test is complete, PASS or FAIL is recorded in the datalogger memory. Pretrip test results can then be viewed through the controller's VIEW/LOG/PT1 submenu. For instructions on viewing the VIEW/LOG/PT1 submenu, refer to "Menu View" in this chapter.

Menu Test Functions

WARNING: Activating some tests in the Menu Test section of the controller menu causes the unit compressor and fan motors to start and operate.

The Test Menu allows technicians to perform specific diagnostic tests on the unit including:

- Electrical [ELECT]: Check the main supply power voltage and frequency; or check the ac current draw of the heaters, motors or unit during Full Cool, Modulation 50%, Modulation 100%, Heat and Defrost.
- Refrigeration [REFRFG]: Perform system diagnostics and check supply and return air temperatures during each unit operating mode.
- Controller [CNTRL]: Perform individual control circuit diagnostics on controller outputs. Valves, solenoids and contactors can be energized without operating the unit or starting the related component (e.g. motor).
- Generator [GEN]: Check the main supply power voltage and frequency provided by a genset while the unit is in Full Cool.

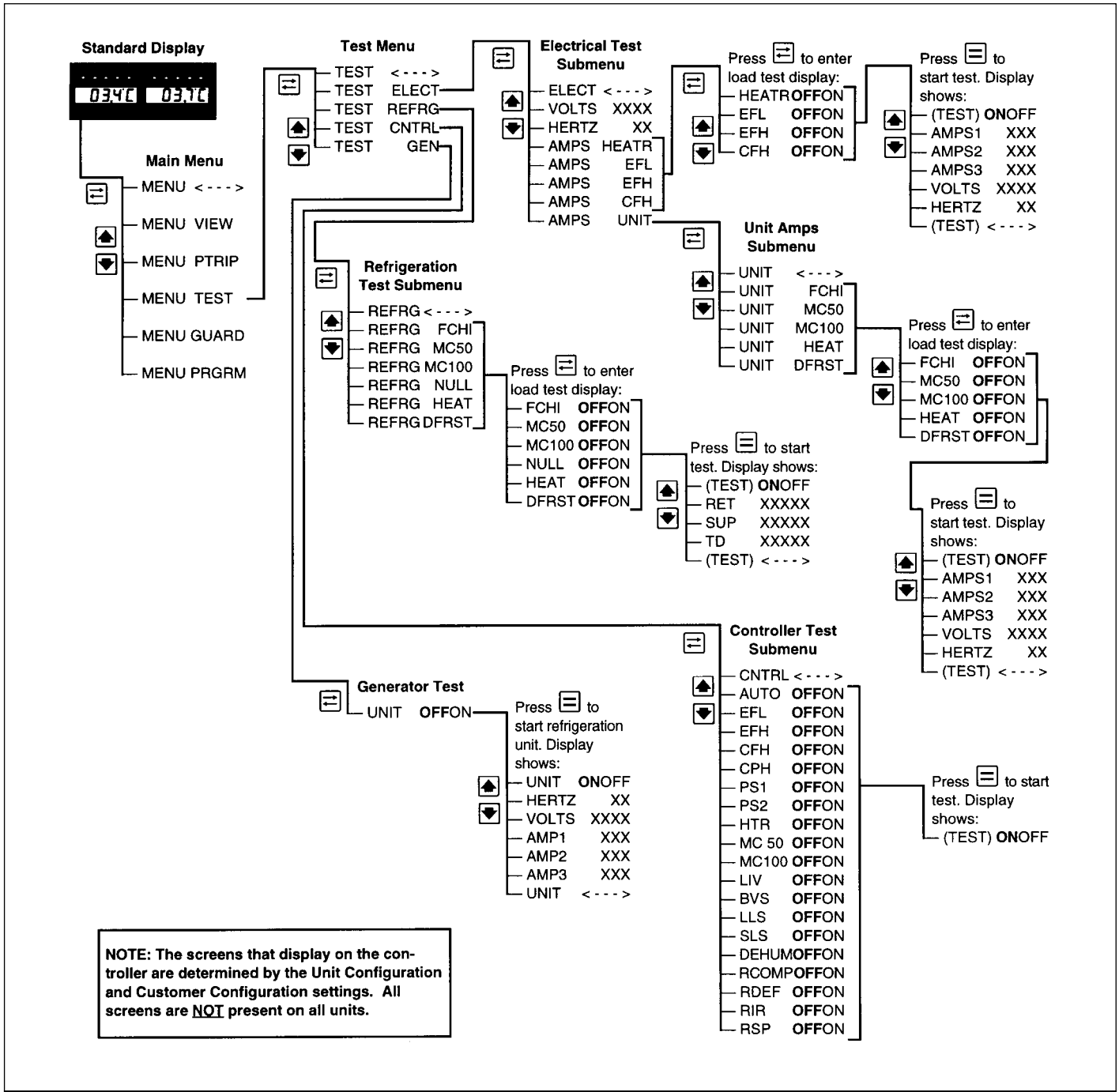

MENU TEST Screen Flow Diagram (See Display Acronym Definitions on pages 4-4 to 4-6)

NOTE: When the Test Menu is entered, the UNIT STOPS. A technician can then select the control circuit or component to be checked/tested from the items shown in the Test Menu.

1. Turn the unit On/Off switch ON.
2. With the controller showing the Standard Display, press the SELECT key to enter menu (display shows "MENU <--->").
3. Press DOWN key until display shows "MENU TEST".
4. Press the SELECT key to enter TEST submenu (display shows "TEST <--->").
5. Press the DOWN key to view functions in submenu. Press the UP key to scroll back through submenu. Left display shows submenu topic "TEST" while the right display shows the sub-submenu topic (e.g. "ELECT").

NOTE: Unit operation STOPS when display shows "TEST ELECT".

6. Press SELECT key to enter a sub-submenu (display shows "ELECT <--->").
7. Press the DOWN key to view functions in sub-submenu. Press the UP key to scroll back through sub-submenu. The display shows the test function (e.g. "AMPS/HTR").
 - a. Press SELECT key to view functions in a test sub-submenu or initiate a test.
 - Display shows submenu function and value (e.g. "HERTZ 60").
 - Display shows test screen (e.g. HTR OFF"ON" with HTR and ON flashing).
 - b. To initiate the test function, press ENTER key.
 - The display shows "HTR "OFF"ON (with HTR and OFF flashing). The heaters should energize.
 - Inspect controller and output module indicator LEDs and contactor to confirm operation.
 - c. To turn the test function OFF, press ENTER key again.
 - Display will show "HTR OFF"ON" (with HTR and OFF flashing).
 - d. Press the UP or DOWN key to scroll to another test function or the top of the submenu.
8. Press and hold the SELECT key for 3 seconds to return to the Standard Display.

Menu Guard Functions

NOTE: An access code is required to enter the Guard menu to prevent unauthorized personnel from tampering with the programmable features.

The Guard menu is used to set many programmable features including:

- Unit Configuration
- Customer Configuration
- Container Identification Number
- Unit Serial Number
- Date and Time
- Unit and Special Hourmeters
- Economy Mode EMAX and EMIN
- Change Temperature Display Units (C/F)
- Sensor Grades

The controller turns OFF all control outputs and suspends normal operation when the Guard menu is entered.

When the Guard Menu is exited, the controller resets and then restarts the unit. This is necessary to be certain that all changes in the programmable features are activated.

Navigating Menu Guard Screens

With the unit On/Off switch ON and the controller showing the Standard Display:

1. Press the SELECT key to enter menu (display shows "MENU <--->").
2. Press DOWN key until display shows "MENU GUARD".
3. Press the SELECT key to enter GUARD submenu (display shows "GUARD <--->").
4. Press the DOWN key. Display shows "GUARD 0000" with left "0" flashing. A flashing digit indicates the digit that can be changed.
5. Enter the current access code "0007".
 - a. Press and release the SELECT key three times to scroll the flashing digit ("0") to the right digit.
 - b. Press and release the DOWN key three times to scroll the flashing digit to "7" (display now shows "GUARD 0007").
 - c. Press the ENTER key to load the code and access the Guard menu. The display will briefly show "GUARD LOAD" and then show "GMENU <--->".

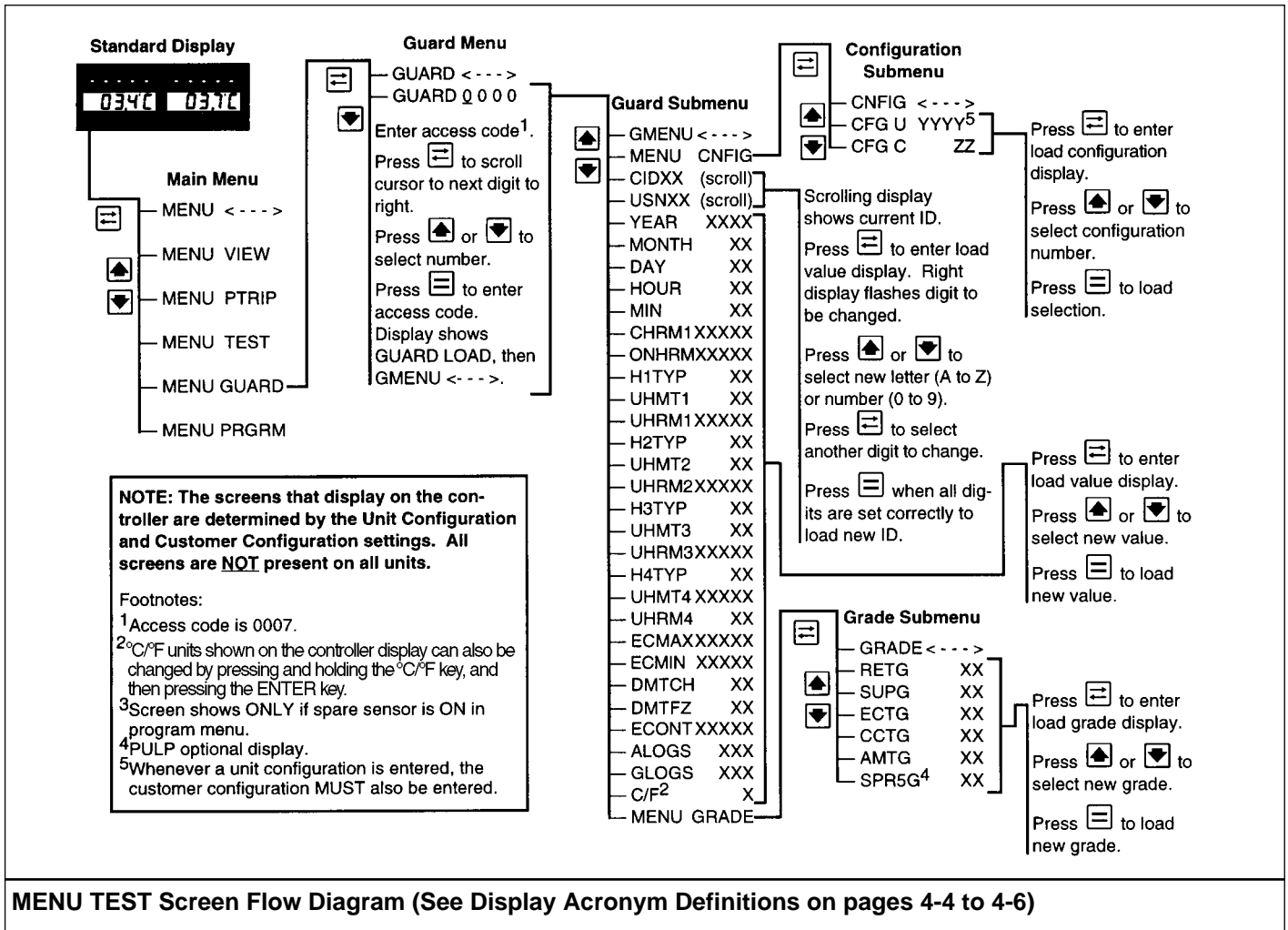

NOTE: If the correct code is not entered, the display returns to “GUARD <--->”.

6. Press the DOWN or UP key to scroll through the menu list.

NOTE: If a new controller or new software has been installed, proceed immediately to “Setting the Unit Configuration and Customer Configuration Numbers” below.

NOTE: If no key is pressed, the controller returns to the “GMENU <--->” display from a Guard Menu screen after 30 seconds. The display returns to the Standard Display 10 seconds later.

Setting the Unit Configuration and Customer Configuration Numbers

1. From “GMENU <--->” in the Guard menu, press the DOWN key until the display shows “MENU CNFIG”).
2. Press the SELECT key to enter Configuration submenu (display shows “CNFIG <--->”).
3. Press the DOWN key until display shows “CFG U 5000” (where “5000” is the default unit configuration when a new controller or software is loaded).

NOTE: If the Unit Configuration has already been set, the current number (YYYY format) will show instead of “5000”. The Unit Configuration MUST always be set first.

4. Press the SELECT key to enter the load configuration display (left display flashes “CFG U”).
5. If the correct unit configuration is not known, check the setup decal in the control box for the correct Unit Configuration number. Then press the UP or DOWN key to scroll to the correct number (number appears in right display).
6. Press the ENTER key to load the configuration number selected. The display will briefly show “CFG U LOAD” and then show the new CFG U setting in the right display.
7. Press the DOWN key until display shows “CFG C 0” (where “0” is the default customer configuration when a new controller or software is loaded; or the Unit Configuration is reset).

NOTE: If the Customer Configuration has already been set, the current number (ZZ format) will show instead of “0”. The Unit Configuration MUST always be set first. The Customer Configuration MUST always be set after the Unit Configuration has been set.

8. Press the SELECT key to enter the load configuration display (left display flashes “CFG C”).
9. If the correct customer configuration is not known, check the setup decal in the control box for the correct Customer Configuration number. Then press the UP or DOWN key to scroll to the correct number (number appears in right display).
10. Press the ENTER key to load the configuration number selected. The display will briefly show “CFG C LOAD” and then show the new CFG C setting in the right display.

NOTE: If a new controller or new software has been installed, proceed immediately to “Setting the Container Identification Number” below.

Setting the Container Identification Number

1. From “CFG C ZZ” (where ZZ is your customer configuration number) in the Guard menu, press the DOWN key until the display shows “CNFIG <--->”.
2. Press the SELECT key to move back to the Guard submenu (display shows “MENU CNFIG”).
3. Press the DOWN key until display shows “CID11 XXX”. Digits in the right display then begin to scroll to the left as the last two digits in the left display indicate the position of the number that is being shown in the right display.
4. Press the SELECT key to enter the load Container Identification Number display. The left display shows “CID11” while the 11th digit flashes in the right display.
 - a. Press the UP or DOWN key to choose a letter (A to Z), a number (0 to 9) or a blank space.
 - b. When the desired character appears in the 11th position, press the SELECT key to choose the next position. The left display shows “CID10” while the 10th digit flashes in the right display.
 - c. Repeat steps a and b for each character until the Container Identification Number is entered.

5. When all characters in the Container Identification Number have been entered, press the ENTER key. The display shows "CID LOAD" and then shows the new number (left display shows CID11 again as the right display shows the 11th digit and begins to scroll to the left again. Check to make sure the Container Identification Number was entered correctly.

NOTE: If a new controller or new software has been installed, proceed immediately to "Setting the Unit Serial Number" below.

Setting the Unit Serial Number

1. From "CID 11 XXX" (where the scrolling XXX is your container identification number) in the Guard menu, press the DOWN key until display shows "USN11 XXX". Digits in the right display then begin to scroll to the left as the last two digits in the left display indicate the position of the number that is being shown in the right display.
2. Press the SELECT key to enter the load Unit Serial Number display. The left display shows "USN11" while the 11th digit flashes in the right display.
 - a. Press the UP or DOWN key to choose a letter (A to Z), a number (0 to 9) or a blank space.
 - b. When the desired character appears in the 11th position, press the SELECT key to choose the next position. The left display shows "USN10" while the 10th digit flashes in the right display.
 - c. Repeat steps a and b for each character until the Unit Serial Number is entered.
3. When all characters in the Unit Serial Number have been entered, press the ENTER key. The display shows "USN LOAD" and then shows the new number (left display shows USN11 again as the right display shows the 11th digit and begins to scroll to the left again. Check to make sure Unit Serial Number was entered correctly.

NOTE: If a new controller or new software has been installed, proceed immediately to "Setting the Date and Time" below.

Setting the Date and Time

1. From "USN 11 XXX" (where the scrolling XXX is your unit serial number) in the Guard menu, press the DOWN key until the display shows "YEAR 1996".
 - a. Press the SELECT key to enter the load Year display (left display flashes "YEAR").
 - b. Press the UP or DOWN key to choose the desired year.
 - c. When the desired year shows in the right display, press the ENTER key. The display shows "YEAR LOAD" and then shows "YEAR YYYY" (where "YYYY" is the new year).
2. If the year is correct, press the DOWN key until the display shows "MONTH MM" (where "MM" is the month).
 - a. Press the SELECT key to enter the load Month display (left display flashes "MONTH").
 - b. Press the UP or DOWN key to choose the desired month.
 - c. When the desired month shows in the right display, press the ENTER key. The display shows "MONTH LOAD" and then shows "MONTH MM" (where "MM" is the new month).
3. If the month is correct, press the DOWN key until the display shows "DAY DD" (where "DD" is the day).
 - a. Press the SELECT key to enter the load Day display (left display flashes "DAY").
 - b. Press the UP or DOWN key to choose the desired day.
 - c. When the desired day shows in the right display, press the ENTER key. The display shows "DAY LOAD" and then shows "DAY DD" (where "DD" is the new day).
4. If the day is correct, press the DOWN key until the display shows "HOUR HH" (where "HH" is the hour).
 - a. Press the SELECT key to enter the load Hour display (left display flashes "HOUR").
 - b. Press the UP or DOWN key to choose the desired hour.
 - c. When the desired hour shows in the right display, press the ENTER key. The display shows "HOUR LOAD" and then shows "HOUR HH" (where "HH" is the new hour).

5. If the hour is correct, press the DOWN key until the display shows "MIN MM" (where "MM" is the minute).
 - a. Press the SELECT key to enter the load Minute display (left display flashes "MIN").
 - b. Press the UP or DOWN key to choose the desired minute.
 - c. When the desired minute shows in the right display, press the ENTER key. The display shows "MIN LOAD" and then shows "MIN MM" (where "MM" is the new minute).
 - a. Press the SELECT key to enter the load Compressor Hourmeter display (left display flashes "ONHRM").
 - b. Press the UP or DOWN key to choose the desired hour setting.
 - c. When the desired hours show in the right display, press the ENTER key. The display shows "ONHRM LOAD" and then shows "ONHRM XXXX" (where "XXXX" is the new Unit On hours).

NOTE: Setting the Compressor, On Time and User Hourmeters is optional when a new controller or new software has been installed. However, the Sensor Grades MUST be set. If you are NOT setting the hourmeters, proceed immediately to "Setting the Sensor Grades".

Setting the Compressor and On Time Hourmeters

NOTE: If the values for the Compressor Run Time Hourmeter (CHRM1) and the Unit On Hourmeter (ONHRM) can be retrieved from the original controller, the values can be duplicated in the new controller.

1. From "GMENU <--->" in the Guard menu, press the DOWN key until the display shows "CHRM1 XXXX" (where "XXXX" is the number of compressor run hours).

NOTE: If the number of compressor run hours can not be determined, leave this setting "0000". Proceed to step 2.

- a. Press the SELECT key to enter the load Compressor Hourmeter display (left display flashes "CHRM1").
- b. Press the UP or DOWN key to choose the desired hour setting.
- c. When the desired hours show in the right display, press the ENTER key. The display shows "CHRM1 LOAD" and then shows "CHRM1 XXXX" (where "XXXX" is the new compressor run hours).
2. From "CHRM1 XXXX" in the controller display, press the DOWN key until the display shows "ONHRM XXXX" (where "XXXX" is the number of unit on hours).

NOTE: If the number of unit on hours can not be determined, leave this setting "0000".

Setting the User Hourmeter Types, User Hourmeter Thresholds and User Hourmeters

NOTE: The procedure for setting H1TYP, H2TYP, H3TYP and H4TYP is the same. The procedure for setting UHMT1, UHMT2, UHMT3 and UHMT4 is the same. The procedure for setting UHRM1, UHRM2, UHRM3 and UHRM4 is also the same. However, if the number of accumulated hours can not be determined, leave UHRM1, UHRM2, UHRM3 and UHRM4 settings at "0000".

1. From "GMENU <--->" in the Guard menu, press the DOWN key until the display shows "H1TYP XX" (where "XX" is the hourmeter type).
 - a. Press the SELECT key to enter the load User Hourmeter Type display (left display flashes "H1TYP").
 - b. Press the UP or DOWN key to choose the desired type setting.

Type Code	Description
0	Timer Turned OFF
1	Evaporator Fan Low Speed Run Time
2	Evaporator Fan High Speed Run Time
3	Not Used
4	Condenser Fan High Speed Run Time
5	Full Cool Mode Run Time
6	Modulation Cool Mode Run Time
7	Null Mode Time
8	Heat Mode Run Time
9	Defrost Mode Run Time
10	Warm Gas Bypass ON Time
11	Power Limit ON Time
12	Liquid Injection ON Time
13	Heaters ON Time

- c. When the desired type number shows in the right display, press the ENTER key. The display shows "H1TYP LOAD" and then shows "H1TYP XXXX" (where "XXXX" is the new type setting).
2. From "H1TYP XXXX" in the controller display, press the DOWN key until the display shows "UHMT1 XX" (where "XX" is the number of threshold hours).
 - a. Press the SELECT key to enter the load User Hourmeter Threshold display (left display flashes "UHMT1").
 - b. Press the UP or DOWN key to choose the desired threshold setting.
 - c. When the desired threshold hours show in the right display, press the ENTER key. The display shows "UHMT1 LOAD" and then shows "UHMT1 XX" (where "XX" is the new threshold hours).
3. From "UHMT1 XX" in the controller display, press the DOWN key until the display shows "UHRM1 XXXX" (where "XXXX" is the number of accumulated user hours).

NOTE: If the number of accumulated user hours can not be determined, leave this setting "0000".

- a. Press the SELECT key to enter the load User Hourmeter display (left display flashes "UHRM1").
- b. Press the UP or DOWN key to choose the desired hour setting.
- c. When the desired hours show in the right display, press the ENTER key. The display shows "UHRM1 LOAD" and then shows "UHRM1 XXXX" (where "XXXX" is the new accumulated user hours).

Setting the Sensor Grades

The Menu Grade submenu (MENU GUARD) displays the sensor grade of each graded sensor installed on the unit.

NOTE: If a sensor grade is set to "0", it means the sensor has been ice bath calibrated. Original unit sensors are ice bath calibrated at the factory and Thermo King recommends ice bath calibration when replacing the Return Air, Supply Air and Coil Temperature Sensors. If an ice bath is NOT available, the controller should be set to the "grade" stamped on each individual sensor.

The Ambient Temperature Sensor and Condenser Coil Temperature Sensor are ungraded sensors and may be calibrated if desired. However, because they are NOT controlling sensors, they do not require calibration. If you do NOT calibrate these ungraded sensors, the ambient sensor and condenser coil sensor grades should be set to "5".

Ice Bath Preparation:

- The ice bath should consist of an insulated container full of ice made from distilled water with enough distilled water added to cover the top of the ice during the test. A properly filled ice bath should be completely filled with ice all the way to the bottom of the container.
- Stir the ice bath briskly for one minute before proceeding.
- Insert the sensors to be calibrated in the ice bath. Wait 5 minutes to allow the sensor temperatures to stabilize at 0 C (32 F).
- Stir the ice bath frequently while testing and verify ice bath temperature with a mercury-in-glass thermometer. Stirring 10 seconds every 3 minutes during the test procedure is adequate.

NOTE: To set the sensor grades, you will need the sensor grade number recorded on the setup decal in the control box. If there is any question about the actual grade of a sensor, physically check the sensor. The grade will be stamped on the side of the sensor.

1. From "GMENU <--->" in the Guard menu, press DOWN key until display shows "MENU GRADE".
2. Press the SELECT key to enter GRADE submenu (display shows "GRADE <--->").
3. Press the DOWN key until "RETG XX" shows in the display (where "XX" is the sensor grade).
 - a. Press the SELECT key to enter the load Sensor Grade display (left display flashes "RETG").

- b. To calibrate the sensor in an ice bath:
 - Press the UP or DOWN key to choose “0” as the grade setting in the right display.
 - Press the ENTER key. Right display briefly shows “CALIB” and then the sensor (ice bath) temperature.
 - When the sensor temperature is within 1.7 C [3 F] above or below 0 C (32 F), the left display (“RET”) begins to flash.
 - Observe the sensor temperature in the right display. When the temperature has been stable for 5 minutes, press the ENTER key. Right display briefly shows “LOAD” and then the sensor temperature.

NOTE: The sensor should be in the ice bath a total of 15 minutes or more to assure the sensor temperature has bottomed out.

- c. To set the sensor grade:
 - Press the UP or DOWN key to choose the desired grade setting.
 - When the desired grade shows in the right display, press the ENTER key. Right display briefly shows “LOAD” and then the new sensor grade).
4. Press the DOWN key until “SUPG XX” shows in the display (where “XX” is the sensor grade).
 - a. Press the SELECT key to enter the load Sensor Grade display (left display flashes “SUPG”).
 - b. To calibrate the sensor in an ice bath:
 - Press the UP or DOWN key to choose “0” as the grade setting in the right display.
 - Press the ENTER key. Right display briefly shows “CALIB” and then the sensor (ice bath) temperature.
 - When the sensor temperature is within 1.7 C [3 F] above or below 0 C (32 F), the left display (“SUP”) begins to flash.
 - Observe the sensor temperature in the right display. When the temperature has been stable for 5 minutes, press the ENTER key. Right display briefly shows “LOAD” and then the sensor temperature.

NOTE: The sensor should be in the ice bath a total of 15 minutes or more to assure the sensor temperature has bottomed out.

- c. To set the sensor grade:
 - Press the UP or DOWN key to choose the desired grade setting.
 - When the desired grade shows in the right display, press the ENTER key. Right display briefly shows “LOAD” and then the new sensor grade).
5. Press the DOWN key until “ECTG XX” shows in the display (where “XX” is the sensor grade).
 - a. Press the SELECT key to enter the load Sensor Grade display (left display flashes “ECTG”).
 - b. To calibrate the sensor in an ice bath:
 - Press the UP or DOWN key to choose “0” as the grade setting in the right display.
 - Press the ENTER key. Right display briefly shows “CALIB” and then the sensor (ice bath) temperature.
 - When the sensor temperature is within 1.7 C [3 F] above or below 0 C (32 F), the left display (“ECT”) begins to flash.
 - Observe the sensor temperature in the right display. When the temperature has been stable for 5 minutes, press the ENTER key. Right display briefly shows “LOAD” and then the sensor temperature.

NOTE: The sensor should be in the ice bath a total of 15 minutes or more to assure the sensor temperature has bottomed out.

- c. To set the sensor grade:
 - Press the UP or DOWN key to choose the desired grade setting.
 - When the desired grade shows in the right display, press the ENTER key. Right display briefly shows “LOAD” and then the new sensor grade).
6. Press the DOWN key until “CCTG XX” shows in the display (where “XX” is the sensor grade).
 - a. Press the SELECT key to enter the load Sensor Grade display (left display flashes “CCTG”).
 - b. To calibrate the sensor in an ice bath:
 - Press the UP or DOWN key to choose “0” as the grade setting in the right display.
 - Press the ENTER key. Right display briefly shows “CALIB” and then the sensor (ice bath) temperature.

- When the sensor temperature is within 1.7 C [3 F] above or below 0 C (32 F), the left display (“CCT”) begins to flash.
- Observe the sensor temperature in the right display. When the temperature has been stable for 5 minutes, press the ENTER key. Right display briefly shows “LOAD” and then the sensor temperature.

NOTE: The sensor should be in the ice bath a total of 15 minutes or more to assure the sensor temperature has bottomed out.

- c. To set the sensor grade:
 - Press the UP or DOWN key to choose the grade setting “5”.
 - When the desired grade shows in the right display, press the ENTER key. Right display briefly shows “LOAD” and then the new sensor grade).

7. Press the DOWN key until “AMTG XX” shows in the display (where “XX” is the sensor grade).
 - a. Press the SELECT key to enter the load Sensor Grade display (left display flashes “AMTG”).
 - b. To calibrate the sensor in an ice bath:
 - Press the UP or DOWN key to choose “0” as the grade setting in the right display.
 - Press the ENTER key. Right display briefly shows “CALIB” and then the sensor (ice bath) temperature.
 - When the sensor temperature is within 1.7 C [3 F] above or below 0 C (32 F), the left display (“AMT”) begins to flash.
 - Observe the sensor temperature in the right display. When the temperature has been stable for 5 minutes, press the ENTER key. Right display briefly shows “LOAD” and then the sensor temperature.

NOTE: The sensor should be in the ice bath a total of 15 minutes or more to assure the sensor temperature has bottomed out.

- c. To set the sensor grade:
 - Press the UP or DOWN key to choose the grade setting “5”.
 - When the desired grade shows in the right display, press the ENTER key. Right display briefly shows “LOAD” and then the new sensor grade).

8. Press the DOWN key until “SPRIG XX” shows in the display (where “XX” is the sensor grade).
 - a. Press the SELECT key to enter the load Sensor Grade display (left display flashes “SPRIG”).
 - b. Press the UP or DOWN key to choose the desired grade setting.
 - c. When the desired grade shows in the right display, press the ENTER key. The display shows “SPRIG LOAD” and then shows “SPRIG XX” (where “XX” is the new sensor grade).
9. Repeat step 8 for each additional spare sensor shown on the setup sheet and installed on the unit.

NOTE: Return controller to the Standard Display by pressing and holding the SELECT key for 3 seconds. Then enter the MENU VIEW or MENU GUARD to check the accuracy of all settings.

Changing the Display Units (C/F)

1. From “GMENU <--->” in the Guard menu, press the DOWN key until the display shows “C/F X”).
2. Press the SELECT key to enter the load configuration display (left display flashes “C/F”).
3. Press the UP or DOWN key to scroll to the desired temperature unit (C = Celsius, F = Fahrenheit).
4. Press the ENTER key to load the configuration unit selected. The display will briefly show “C/F LOAD” and then show the new C/F setting in the right display.

NOTE: Return the controller to the Standard Display by pressing and holding the SELECT key for 3 seconds. Then check to be sure that the display shows the correct temperature unit.

Menu Program Functions

NOTE: When the unit is OFF, the following options default to OFF after 48 hours (v11.71 to 11.73 software) or 96 hours (v11.74 and above software): Bulb Mode, Dehumidify, Economy Mode, Humidify, Pulp Mode and USDA Mode.

The Program Menu allows technicians to set specific control functions.

- Turn the unit On-Off switch ON or operate controller using battery power.
- Press the SELECT key to enter menu (display shows “MENU <--->”).
- Press DOWN key until display shows “MENU PRGRM”.
- Press the SELECT key to enter PRGRM submenu (display shows “PRGRM <--->”).
- Press and hold the SELECT key for 3 seconds to return to the Standard Display.

Program Menu List

- <---> Top of menu
- USDA USDA sensor recording (3 or 4 sensors) On/Off
- USDA1 Spare 1 sensor On/Off
- USDA2 Spare 2 sensor On/Off
- USDA3 Spare 3 sensor On/Off
- PULP Pulp recording On/Off
- ECON Economy mode On/Off
- HUM Dehumidify or Humidify On/Off
 - HUMSP = Enter Humidity setpoint (50% to 100%)
- BULB Bulb mode On/Off
 - BDFTT = Enter Bulb mode defrost termination temperature
 - BEFAN = Enter Bulb mode evaporator fan speed (high, low or cycle)
- PWRED Power Reduction 1, 2 or 3

USDA Sensors

Changing the USDA program screen from OFF to ON activates spare sensors 1, 2 and 3 for USDA Cold Treatment Temperature Recording. USDA sensor temperatures are recorded in the data logger memory.

The USDA sensors should be connected to the controller and located in the load as shown in USDA directives. When a USDA sensor is installed, the controller will automatically detect the sensors and activate data logging. The controller Program menu shows the USDA sensor number in the left display and “AUTO” in the right display if data logging is active. However, the USDA program screen MUST be set to ON and each USDA sensor MUST be calibrated to comply with USDA temperature recording requirements. Calibrate the sensors in an ice bath. The µP-D controller requires a USDA sensor, P/N 41-3107.

Ice Bath Preparation

1. The ice bath should consist of an insulated container full of ice made from distilled water with enough distilled water added to cover the top of the ice during the test. A properly filled ice bath should be completely filled with ice all the way to the bottom of the container.
2. Stir the ice bath briskly for one minute before proceeding.
3. Insert the USDA sensors in the ice bath. Wait 5 minutes to allow the sensor temperatures to stabilize at 0 C (32 F).
4. Stir the ice bath frequently while testing and verify ice bath temperature with a mercury-in-glass thermometer. Stirring 10 seconds every 3 minutes during the test procedure is adequate.

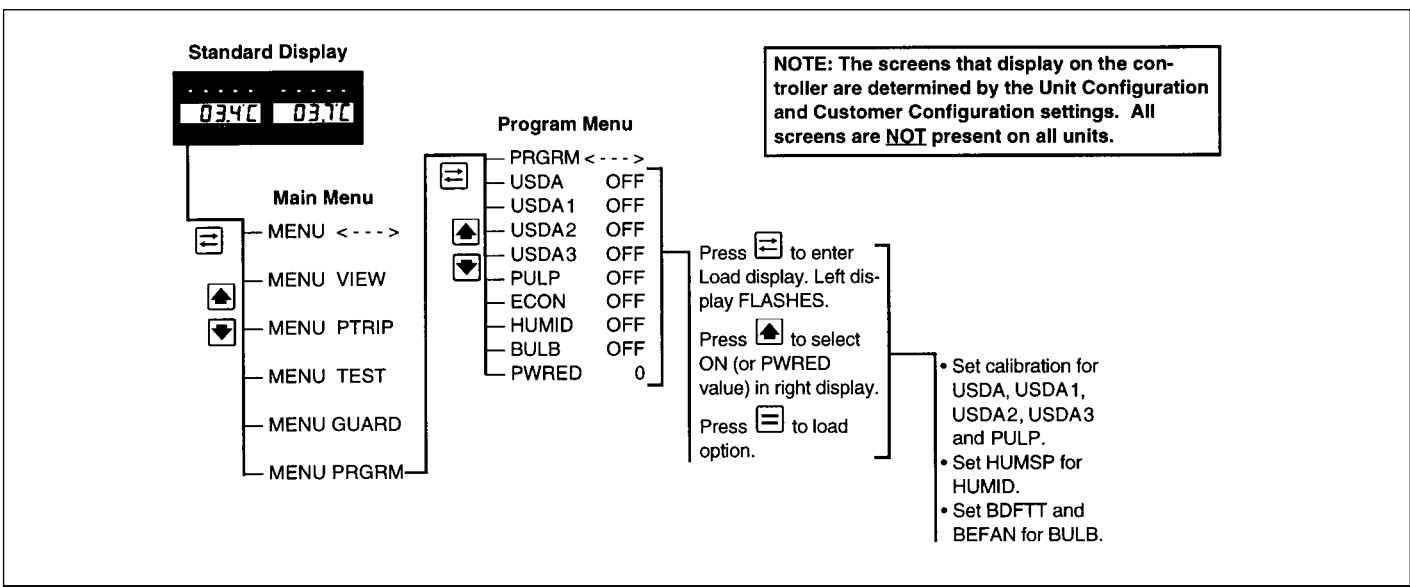

MENU PROGRAM Screen Flow Diagram (See Display Acronym Definitions on pages 4-4 to 4-6)

Setting and Calibrating the USDA Sensors

1. Insert all USDA sensors in an ice bath (see “Ice Bath Preparation” above).

NOTE: The sensors must be completely immersed in the ice bath without contacting the walls of the ice bath container for 5 minutes.

2. Press the SELECT key to enter menu (display shows “MENU <--->”).
3. Press DOWN key until display shows “MENU PRGRM”.
4. Press the SELECT key to show “PRGRM <--->”.
5. Press the UP or DOWN key until the display shows the current “USDA” setting:
 - “USDA OFF”
 - “USDA ON”
6. To change the current setting, press SELECT key. “USDA” will begin to flash in the left display.
7. Press the UP or DOWN key to scroll the right display to the desired setting.
8. To load the new setting, press the ENTER key. The display briefly shows “USDA LOAD”.
9. When the USDA mode is turned ON, the display then shows “USDA ON”. Each USDA sensor must now be calibrated for accurate temperature recording. To calibrate the USDA1 sensor:
 - a. Press the DOWN key to show “USDA1 ON” in the display.
 - b. To calibrate the USDA1 sensor, press the SELECT key. “USDA1” will begin to flash in the left display.
 - c. Press the UP or DOWN key to show “CAL” in the right display.
 - d. Press the ENTER key. The display briefly shows “USDA1 CALIB”. The left display then shows “USDA1” and the right display shows the sensor temperature (“00.0 C”).
 - e. When USDA1 sensor temperature is within 1.7 C [3 F] above or below 0 C (32 F), the left display (“USDA1”) begins to flash.
 - f. Observe the sensor temperature in the right display. When the temperature has been stable for 5 minutes, press the ENTER key. The display briefly shows “USDA1 LOAD”, then “USDA1” and the sensor temperature (“00.0 C”), and returns to the “USDA1 ON” display.

NOTE: The sensors should be in the ice bath a total of 15 minutes or more to assure the sensor temperature has bottomed out.

- g. Repeat steps 8a through 8f to calibrate the USDA2 and USDA3 sensors.

NOTE: Press and hold the SELECT key for 3 seconds to return to the Standard Display.

PULP Sensor (Option)

Changing the PULP program screen from OFF to ON activates the PULP (spare 5 sensor) temperature recording. PULP sensor temperatures are recorded in the data logger memory.

The Pulp sensor should be connected to the controller and located in the load as specified by the customer and/or shipping company. When a PULP sensor is installed, the controller will automatically detect the sensor and activate data logging. The controller Program menu shows the “PULP” in the left display and “AUTO” in the right display if data logging is active. However, the PULP program screen MUST be set to ON and the sensor MUST be calibrated to accurately record temperature. Calibrate the sensor in an ice bath (see “Ice Bath Preparation” under USDA Sensors in this chapter).

Setting and Calibrating the Pulp Sensor

1. Insert Pulp sensor in an ice bath (see “Ice Bath Preparation” above).

NOTE: The sensor must be completely immersed in the ice bath without contacting the walls of the ice bath container for 5 minutes.

2. Press the SELECT key to enter menu (display shows “MENU <--->”).
3. Press the UP key until display shows “MENU PRGRM”.
4. Press the SELECT key to show “PRGRM <--->”.
5. Press the UP or DOWN key to show the current “PULP” setting:
 - “PULP OFF”
 - “PULP ON”
6. To change the current setting, press SELECT key. “PULP” will begin to flash in the left display.
7. Press the UP or DOWN key to scroll the right display to the desired setting.

8. To load the new setting, press the ENTER key. The display briefly shows "PULP LOAD".
9. When the PULP mode is turned ON, the display then shows "PULP ON". The PULP sensor must now be calibrated for accurate temperature recording. To calibrate the PULP sensor:
 - a. To calibrate the PULP sensor, press the SELECT key while "PULP ON" appears in the display. "PULP" will begin to flash in the left display.
 - b. Press the UP or DOWN key to show "CAL" in the right display.
 - c. Press the ENTER key. The display briefly shows "PULP CALIB". The left display then shows "PULP1" and the right display shows the sensor temperature ("00.0 C").
 - d. When PULP1 sensor temperature is within 1.7 C [3 F] above or below 0 C (32 F), the left display ("PULP1") begins to flash.
 - e. Observe the sensor temperature in the right display. When the temperature has been stable for 5 minutes, press the ENTER key. The display briefly shows "PULP1 LOAD", then "PULP1" and the sensor temperature ("00.0 C"), and returns to the "PULP ON" display.

NOTE: The sensors should be in the ice bath a total of 15 minutes or more to assure the sensor temperature has bottomed out.

NOTE: Press and hold the SELECT key for 3 seconds to return to the Standard Display.

Economy Mode

The Economy Mode reduces unit power consumption by reducing evaporator fan operation. On frozen loads, the Economy mode also modifies the temperature control algorithm to extend the Null mode. The use of the Economy Mode should be established by the shipper and the type of cargo. The Economy Mode option is turned on from Program menu of the controller.

NOTE: If the Economy Mode is set to ON, the controller display will show "ECON ON" for 1 second every 10 seconds.

- Chill Loads (return air temperatures of -9.9 C (14.1 F) and above): Evaporator fans operate on low speed whenever the container temperature is In-range.
- Frozen Loads (return air temperatures of -10 C (14 F) and below): Unit continues on Cool operation until return air temperature reaches ECMIN temperature. Default ECMIN setting is 2.0 C (3.6 F) below setpoint. ECMIN temperature is adjustable from 0 to 10 C (0 to 18 F) below setpoint through the Guard menu of the controller.

The evaporator fans stop during the Null mode (on frozen loads). A null state timer automatically starts and operates the evaporator fans on low speed for 5 minutes every 45 minutes. The unit remains in Null until the return air temperature increases to ECMAX temperature and a 45 minute Null state time sequence expires. Default ECMAX setting is 1.0 C (1.8 F) above setpoint. ECMAX setting is adjustable from 0 to 10 C (0 to 18 F) above setpoint through the Guard menu of the controller.

NOTE: See "Menu Guard" for detailed information about changing ECMIN and ECMAX from the default settings.

Setting the Economy Mode

1. Press the SELECT key to enter menu (display shows "MENU <--->").
2. Press UP key until display shows "MENU PRGRM".
3. Press the SELECT key to show "PRGRM <--->".
4. Press the UP or DOWN key until the display shows the current setting:
 - "ECON OFF"
 - "ECON ON"
5. To change the current setting, press SELECT key. "ECON" will begin to flash in the left display.
6. Press the UP or DOWN key to scroll the right display to the desired setting.
7. To load the new setting, press the ENTER key. The display briefly shows "ECON LOAD". When the Economy mode is turned ON, the display then shows "ECON ON".

NOTE: Press and hold the SELECT key for 3 seconds to return to the Standard Display.

Dehumidify Mode (Option)

The Dehumidify Mode reduces the humidity level in the container by condensing more moisture from the container air. More moisture is condensed from the air by lowering the evaporator coil temperature. The use of the Dehumidify Mode should be established by the shipper. The Dehumidify Mode option is turned on from the Program menu of the controller.

NOTE: If the Dehumidify Mode is set to ON, the controller display will show “DEHUM” in the left display and the container humidity level (e.g. “74.5”) in the right display for 1 second every 10 seconds.

When the Dehumidify Mode is ON:

- The supply air temperature must be In-range before the controller will operate the dehumidify function.
- When the dehumidify function is operating (dehumidify valve energized), the supply air LED will flash ON and OFF.
- The controller energizes (closes) the dehumidify valve when the humidity level in the container is between 1% and 5% above the humidity setpoint. This reduces the size of the evaporator providing cooling by 50%, causing the coil to become colder and condense more moisture from the container air.
- The controller energizes (closes) the dehumidify valve and pulses the electric heaters ON and OFF when the humidity level in the container is 5% or more above the humidity setpoint. This increases the cooling load and causes the evaporator coil to become even colder, condensing more moisture from the container air.

Setting the Dehumidify Mode

1. Press the SELECT key to enter menu (display shows “MENU <--->”).
2. Press UP key until display shows “MENU PRGRM”.
3. Press the SELECT key to show “PRGRM <--->”.
4. Press the UP or DOWN key until the display shows the current “HUMID” setting:
 - “HUMID OFF”.
 - “HUMID DEHUM” — Dehumidify option is ON.
 - “HUMID HUM” — Humidify option is ON.

NOTE: The Dehumidify and Humidify option screens do not appear unless the unit is equipped with the option and the controller is set to the correct unit configuration. Also, the Dehumidify and Humidify options can NOT be turned ON at the same time.

5. To change the current setting, press the SELECT key. “HUMID” will begin to flash in the left display.
6. Press the UP or DOWN key to scroll the right display to the desired setting: “DEHUM”, “HUM” or “OFF”.
7. To load the new setting, press the ENTER key. The display briefly shows “HUMID LOAD”.
8. When the Dehumidify mode is turned ON, the left display shows “HUMSP” and the right display shows the current humidity setpoint in percent (e.g. “85.0”). To change the humidity setpoint:
 - a. Press the SELECT key. “HUMSP” will flash in the left display.
 - b. Press the UP or DOWN key to adjust the humidity setpoint to the desired setting (see shipping manifest). The right display scrolls up or down to the new humidity setpoint in percent (e.g. “70.0”).
 - c. To load the new setpoint, press the ENTER key. The display briefly shows “HUMSP LOAD”. The new humidity setpoint then shows in the right display (e.g. “70.0”).

NOTE: Press and hold the SELECT key for 3 seconds to return to the Standard Display.

Humidify Mode (Option)

The Humidify Mode increases the humidity level in the container by injecting atomized water directly into the evaporator supply air stream. The use of the Humidify Mode should be established by the shipper. The Humidify Mode option is turned on from the Program menu of the controller.

NOTE: If the Humidify Mode is set to ON, the controller display will show “HUM” in the left display and the container humidity level (e.g. “74.5”) in the right display for 1 second every 10 seconds.

When the Humidify Mode is ON:

- The evaporator fans must be ON before the controller will operate the humidify function.
- When the humidify function is operating (air compressor energized), the supply air LED will flash ON and OFF.
- The controller energizes (operates) the air compressor when the humidity level in the container is more than 2% below the humidity setpoint. The air compressor atomizes and injects water into the evaporator supply air stream to add moisture to the container air.

Setting the Humidify Mode

1. Press the SELECT key to enter menu (display shows “MENU <--->”).
2. Press UP key until display shows “MENU PRGRM”.
3. Press the SELECT key to show “PRGRM <--->”.
4. Press the UP or DOWN key until the display shows the current “HUMID” setting:
 - “HUMID OFF”.
 - “HUMID DEHUM” — Dehumidify option is ON.
 - “HUMID HUM” — Humidify option is ON.

NOTE: The Dehumidify and Humidify option screens do not appear unless the unit is equipped with the option and the controller is set to the correct unit configuration. Also, the Dehumidify (or Bulb) and Humidify options can NOT be turned ON at the same time.

5. To change the current setting, press the SELECT key. “HUMID” will begin to flash in the left display.
6. Press the UP or DOWN key to scroll the right display to the desired setting: “DEHUM”, “HUM” or “OFF”.
7. To load the new setting, press the ENTER key. The display briefly shows “HUMID LOAD”.
8. When the Humidify mode is turned ON, the left display shows “HUMSP” and the right display shows the current humidity setpoint in percent (e.g. “70.0”). To change the humidity setpoint:
 - a. Press the SELECT key. “HUMSP” will flash in the left display.
 - b. Press the UP or DOWN key to adjust the humidity setpoint to the desired setting (see shipping manifest). The right display scrolls up or down to the new humidity setpoint in percent (e.g. “85.0”).
 - c. To load the new setpoint, press the ENTER key. The display briefly shows “HUMSP LOAD”. The new humidity setpoint then shows in the right display (e.g. “85.0”).

NOTE: Press and hold the SELECT key for 3 seconds to return to the Standard Display.

Bulb Mode (Option)

Changing the Bulb screen from OFF to ON automatically activates the Dehumidify Mode and allows the defrost termination temperature and evaporator fan speed to be set. The use of the Bulb Mode should be established by the shipper. When the Bulb Mode is ON:

- The Dehumidify Mode is ON. See “Dehumidify Mode (Option)” on page 4-39 for a description of the dehumidify system operation.
- The defrost termination temperature (“BDFTT”) can be adjusted from 4 to 30 C (40 to 86 F). Lower defrost termination settings may result in less warming of the cargo during defrost.
- The evaporator fan speed (“BEFAN”) can be set to High Speed, Low Speed or Cycle (fans cycle between high and low speed every 60 minutes).

NOTE: If the Bulb Mode is set to ON, the controller display will show “BULB ON” for 1 second every 10 seconds. Also, the display will show “DEHUM” in the left display and the container humidity level (e.g. “74.5”) in the right display for 1 second every 10 seconds. Also, the Bulb and Humidify options can NOT be turned ON at the same time.

Setting the Bulb Mode

1. Press the SELECT key to enter menu (display shows “MENU <--->”).
2. Press DOWN key until display shows “MENU PRGRM”.
3. Press the SELECT key to show “PRGRM <--->”.
4. Press the UP or DOWN key to show the current setting:
 - “BULB OFF”
 - “BULB ON”
5. To change the current setting, press SELECT key. “BULB” will begin to flash in the left display.
6. Press the UP or DOWN key to scroll the right display to the desired setting.
7. To load the new setting, press the ENTER key. The display briefly shows “BULB LOAD”. When the Bulb Mode is turned ON, the display then shows “BULB ON”.

NOTE: Setting the Bulb mode to OFF does not automatically set the Dehumidify mode to OFF too. To de-activate Dehumidify operation, see “Dehumidify Mode” earlier in this chapter.

8. When the Bulb mode is ON, the defrost termination temperature screen “BDFTT” appears in the Program menu. To change the defrost termination temperature:
 - a. With “BULB ON” in the display, press the DOWN key to scroll to the “BDFTT” screen. The current setting appears in the right display (factory default is 30.0 C (86.0 F)).
 - b. Press the SELECT key. “BDFTT” will flash in the left display.
 - c. Press the UP or DOWN key to adjust the defrost termination temperature to the desired setting (see shipping manifest). The right display scrolls up or down to the new temperature setting (e.g. “20.0”).
 - d. To load the new temperature, press the ENTER key. The display briefly shows “BDFTT LOAD”.
 - e. The display then shows “BEFAN” in the left display and the current evaporator fan speed selection in the right display (e.g. “HI”).
9. When the Bulb mode is ON, the current evaporator fan speed screen “BEFAN” appears in the Program menu. To change the fan speed selection:
 - a. With “BULB ON” in the display, press the DOWN key to scroll to the “BDFTT” screen. If a new defrost termination temperature was set, the “BEFAN” screen already appears. The current setting appears in the right display (factory default is HI).
 - b. Press the SELECT key. “BEFAN” will flash in the left display.
 - c. Press the UP or DOWN key to adjust the evaporator fan speed to the desired setting (see shipping manifest): “HI”, “LO” or “CYCLE”.
 - d. To load the new setting, press the ENTER key. The display briefly shows “BEFAN LOAD”. The display then shows “BEFAN” in the left display and the current fan speed selection in the right display (e.g. “CYCLE”).

NOTE: Press and hold the SELECT key for 3 seconds to return to the Standard Display.

Power Reduction Mode

Changing the Power Reduction program screen from OFF to ON activates the power reduction control algorithm that reduces total unit electric power consumption for 8 hours. The use of the Power Reduction Mode should be established by the shipper. When the Power Reduction Mode is ON:

- The controller reduces the electric power consumption by the percent selected: 10%, 20% or 30%.

NOTE: When the Power Reduction Mode is active, the controller display will briefly show “PWRED ON” every 10 seconds.

Setting the Power Reduction Mode

1. Press the SELECT key to enter menu (display shows “MENU <--->”).
2. Press DOWN key until display shows “MENU PRGRM”.
3. Press the SELECT key to show “PRGRM <--->”.
4. Press the DOWN key to show the current setting, “PWRED 0” (OFF); or “PWRED 1”, “PWRED 2”, “PWRED 3” (ON).
5. Press SELECT key. “PWRED” will begin to flash.
6. Press the UP or DOWN key to scroll the right display to the desired setting:
 - 0 = OFF
 - 1 = 10% Power Reduction
 - 2 = 20% Power Reduction
 - 3 = 30% Power Reduction

NOTE: The cooling capacity of the unit may be reduced when the Power Reduction Mode is active. The greater the reduction in electric power (e.g. “2” or “3” setting), the greater the likelihood of unit cooling capacity reduction. The use of the Power Reduction Mode should be established by the shipper.

7. Press the ENTER key to load the power reduction setting selected. The display briefly shows “PWRED LOAD”. Left display then shows “PWRED” and the right display shows the new power reduction setting (e.g. “1”).

NOTE: Press and hold the SELECT key for 3 seconds to return to the Standard Display.

Controller Emergency Bypass Procedure

In the event the controller fails or the serial communications link between the output module and the controller fails, the output module will operate the unit as follows:

- Chill (Fresh) Loads: Output module STOPS all compressor and fan motor operation.
- Frozen Loads: Output module operates unit in Full Cool mode.

In the event of an emergency situation where the Output Module also fails and replacement parts are not available, the Emergency Bypass Module may be used to manually control the unit.

NOTE: It may be necessary to partially close (manually) the liquid line service valve to regulate the flow of refrigerant.

WARNING: High voltage (460/380 volts) is present on the contactors and relays in the control box. To prevent dangerous electrical shock, disconnect the supply power to the unit whenever possible when working in this area.

1. Turn the Unit On/Off switch to OFF.
2. Disconnect the unit power cord from the power supply.
3. Disconnect wire harness connector "C1" from the bottom of the Output Module and connect it to the bottom of the Emergency Bypass Module.

NOTE: Make sure the Phase Rotation Switch on the Emergency Bypass Module is OFF.

4. Connect the unit power cord to the proper power supply.
5. Turn the Unit On/Off switch to ON. The VIN LED on the Emergency Bypass Module will turn ON to indicate power is available at the module.
6. Place the Phase Rotation Switch in the ABC position to start the unit.
 - a. Place the Mode Switch to Full Cool position to operate compressor and condenser fan. Check condenser fan airflow. Air should be blowing out from the center of the grille.
 - b. If air is NOT blowing out from the center of the grille, place the Phase Rotation switch in the OFF position. Allow the motors and fans to come to a COMPLETE stop. Then place the Phase Rotation

switch in the CBA position. Check condenser airflow again to confirm that air is blowing out from the center of the grille.

8. Use the Mode Switch to set unit operation for Evaporator Fan Only or Full Cool operation.

CAUTION: The unit must be cycled manually to maintain the desired temperature. Monitor container temperature using the controller display (if working) or an external thermometer.

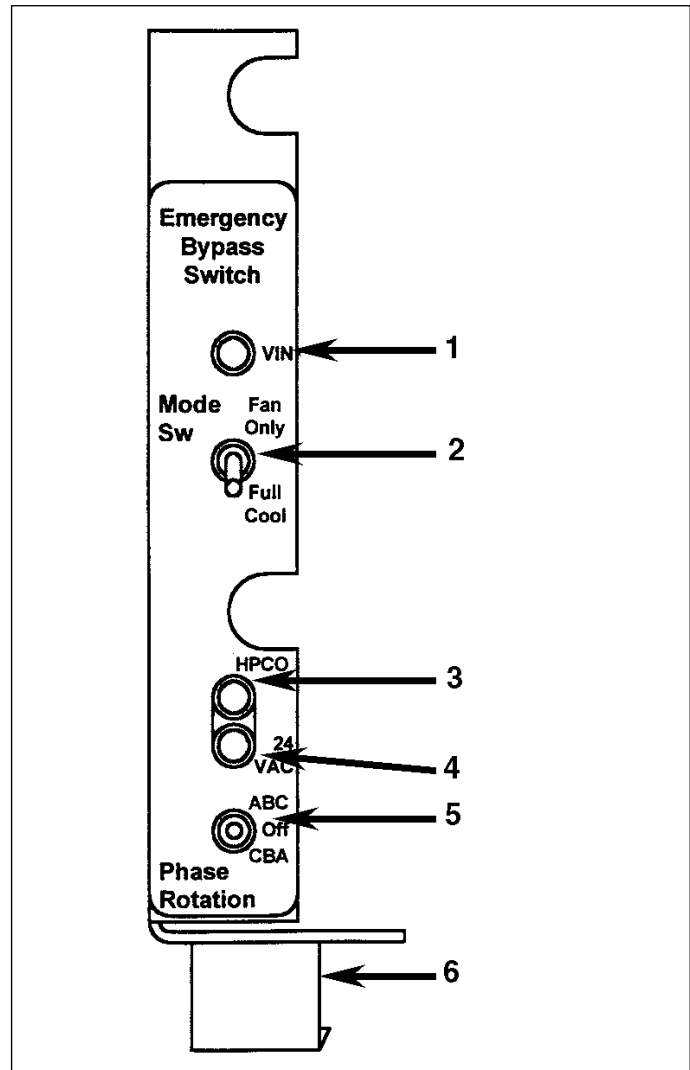

Emergency Bypass Module

1. VIN LED
2. Mode Switch
3. High Pressure Cutout (HPCO) LED
4. 24 Vac LED
5. Phase Rotation Switch
6. Attach Wire Harness Connector C1 Here

9. High Pressure Cutout (HPCO) and 24 Vac LEDs on the Emergency Bypass Module turn ON to indicate normal operation.
 - The HPCO LED is ON when the HPCO switch is closed (normal) and turns OFF when the HPCO switch is open (high discharge pressure).
 - THE 24 Vac LED is ON when 24 volt ac control power is supplied to the Emergency Bypass Module for Emergency Bypass unit operation.

NOTE: If emergency bypass procedures are used under high ambient and high container (load) temperature conditions, a compressor motor shutdown may occur (indicating the compressor motor internal overload protector has tripped). Wait a few minutes to allow the overload protector to cool.

The unit is equipped with a suction modulation capacity control system to control system cooling capacity and limit compressor motor current draw. If the unit shuts down due to the overload protector tripping during emergency bypass procedure operation, restrict refrigerant flow to the compressor using the liquid line service valve. Manually close the valve and then open the valve 1/4 turn. Restart the unit. Check compressor motor current draw. The motor should draw 14 to 15 amps. Adjust the liquid line service valve slightly if necessary to raise or lower current draw to 14 to 15 amps.

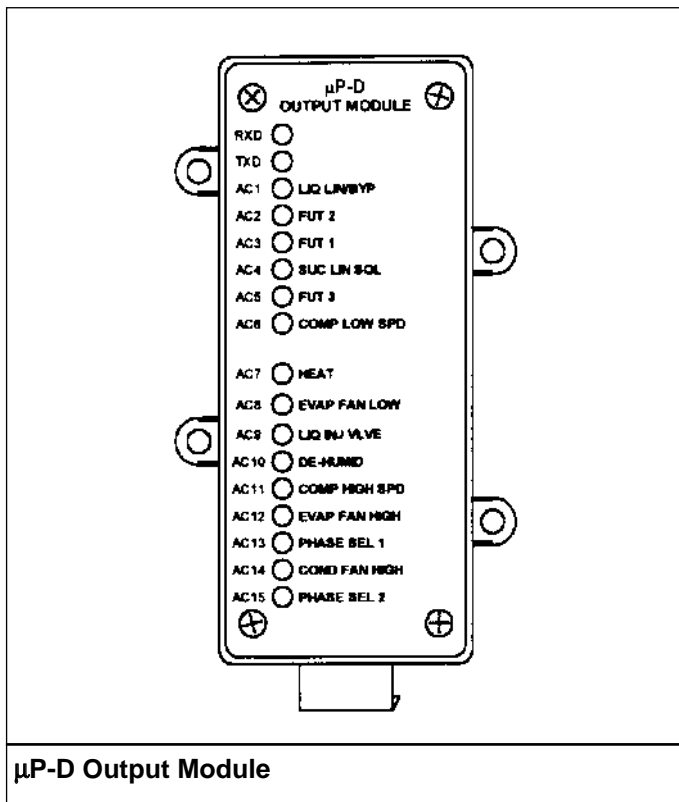

µP-D Output Module

Output Module

The controller uses the output module to energize and de-energize unit contactors and solenoids. Controller commands are transmitted from the controller to the output module through the CAN terminal using serial communications commands. Indicator LEDs on the Output Module turn ON to show an output is energized. The RXD and TXD LEDs alternately flash continuously to show the communications connection is good. If one or both of the RXD and TXD LEDs do NOT flash, the communications connection is open or defective. The output module contains no user serviceable parts.

In the event the controller fails or the serial communications link between the output module and the controller fails, the output module will operate the unit as follows:

- Chill (Fresh) Loads: Output module STOPS all compressor and fan motor operation.
- Frozen Loads: Output module operates unit in Full Cool mode.

Thermo Bus Tap

Serial communications commands are transmitted from the µP-D controller through the Thermo Bus Tap to the Output Module on two wires (labeled blue and white). An open or defective communications circuit is indicated when one or both of the RXD and TXD LEDs on the Output Module do NOT flash.

In the event the serial communications link between the output module and the controller fails, the output module will operate the unit as follows:

- Chill (Fresh) Loads: Output module STOPS all compressor and fan motor operation.
- Frozen Loads: Output module operates unit in Full Cool mode.

Power Module

The power module supplies low voltage control power and ground to the µP-D controller and the Output Module. The power module also supplies power to the KVQ valve circuit and the serial communications line. Fuses on the printed circuit board provide current overload protection to the unit control circuits. The power module derives power from the control power transformer. Always disconnect the main supply power before working on the power module board.

Replacing the μ P-D Controller

CAUTION: When replacing a controller, correct unit operation requires that the Unit Configuration, Customer Configuration and programmable Sensor Grades be set to the UNIT specific features and sensors.

A replacement controller contains default settings that allow it to function when installed in a unit. However, CORRECT unit operation REQUIRES that the Unit Configuration, Customer Configuration and programmable Sensor Grades be set to the UNIT specific features and sensors. If this information can not be recovered from the previous controller, see the unit configuration and sensor grade information on the set up decal located on the control box door. Then program these settings before releasing the unit for service. See "Menu Guard" section for instructions on programming the controller.

There are many other programmable features that may need to be set to completely configure the unit to customer specifications. Customer requirements may include features such as the container identification number and unit serial number. Adjust any additional programmable settings to customer requirements before releasing the unit for service.

1. Write down the Unit Configuration Number, Customer Configuration Number, Container Identification Number, Hourmeter settings and Sensor Grades on a blank setup sheet. Recover as much information as possible from the previous controller. If the previous controller is non-functional, see the setup decal located on the control box door for the Unit Configuration Number, Customer Configuration Number and Sensor Grades. The Unit Serial Number is located on the Unit Nameplate.
2. Turn the unit On/Off switch OFF. Then unplug the unit power cord from the power supply.
3. Disconnect the wire harness connectors from the back of the controller.
4. Remove the screws that secure the controller to the control box door.
5. Remove the controller and gasket from the door.
6. Install the replacement controller and gasket in the door using the existing hardware.

CAUTION: Do NOT over tighten the mounting hardware or the controller may be damaged.

7. Attach the wire harness connectors to the back of the controller.

NOTE: Be certain that all connectors are fully seated until the connector rings lock.

8. Plug the unit power cord into the proper power supply.
9. Turn the unit On/Off switch ON. The unit should start and the Standard Display should appear on the controller.

CAUTION: Immediately proceed to procedure for "Setting the Unit Configuration and Customer Configuration Numbers" in the "Menu Guard" section of this chapter. Alarm code 42 should be present in the display when the Alarm key is pressed. This indicates that the correct Unit Configuration, Customer Configuration and Sensor Grades must still be set.

Temperature Sensors

All sensors should be properly installed:

- Supply sensor installs in the sensor tube next to the control box. The sensor must be inserted to the bottom of the sensor tube and completely sealed by the grommet connection.
- Return air sensor installs in a grommet between the evaporator fans.
- Evaporator coil sensor must be placed in the coil fins between tube rows 2 and 3 in the middle of the coil.
- Condenser sensor must be placed on the left side of the condenser coil and at least 70 mm deep between the fins.
- Ambient sensor must be placed on the bottom plate of the right forklift pocket.
- Compressor discharge gas temperature sensor must be placed in the back side of the compressor head.

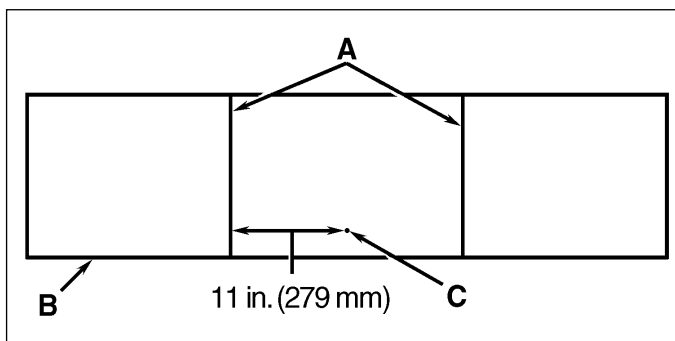

Evaporator Coil Sensor Location — Units with Three Evaporator Fans

- A. Coil Support Brackets
- B. Unit Front
- C. Insert Sensor between Tube Rows 2 and 3

Semiconductor Type Sensors

Electronic semiconductor type temperature sensors are used for:

- Supply Air
- Return Air
- Evaporator Coil
- Condenser Coil
- Ambient Air

Semiconductor sensors can not be checked with an ohmmeter. If an alarm code indicates a sensor failure, check the sensor by substitution. The supply air, return air and evaporator coil sensors are graded sensors. Graded sensors can also be ice bath calibrated. The µP-D controller will not operate correctly if the return air, supply air and evaporator coil sensors are not ice bath calibrated or the correct sensor grades are not in the controller.

The condenser coil and ambient air sensors are non-graded sensors. Non-graded sensor do not require ice bath calibration.

Thermistor Type Sensors

Thermistor type temperature sensors are used for:

- Compressor Discharge Gas Temperature Sensor

If an alarm code indicates a failed sensor, check the sensor by substitution.

Diagnosis and Repair

If the unit appears to be operating incorrectly, view any alarm codes that may be stored in the controller display memory. Diagnose and correct the problem associated with each alarm code (see “Alarm Codes, Alarm Types and Corrective Actions” in this chapter).

If you have viewed and corrected these problems and the unit still appears to be operating incorrectly, eliminate any possibility that the problem is caused by failure of components other than the controller.

External Cause Checks

- Poor contact between male and female connector plugs (loose connection).
- Defective wire harness (broken wires, loose connections).
- External electrical causes such as faulty (open or stuck) contactors.
- Malfunction of refrigeration system components.

NOTE: For complete diagnosis and corrective action information about the controller and unit components, see the *Diagnosis Manual for THERMO-GUARD µP-D Microprocessor Controller, TK 41230.*

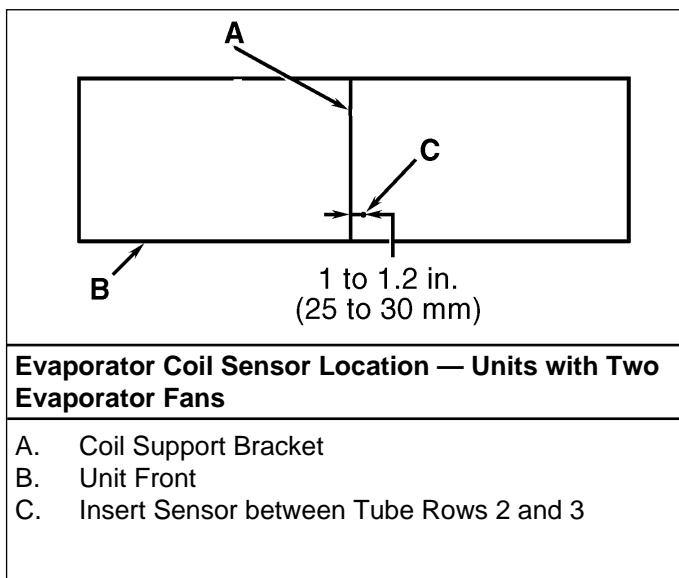

Alarm Codes, Descriptions and Corrective Actions

Code	Description	Corrective Action
00	No Fault	<ul style="list-style-type: none"> • None Required
02	<p>Ambient Temperature Sensor Failure (Check Alarm)</p> <ul style="list-style-type: none"> • Indicates a problem exists with this sensor or its wiring. The sensor is reading out-of-range; or appears to be open or shorted. • This sensor does NOT require ice bath calibration. 	<ul style="list-style-type: none"> • Check the sensor by selecting it using the View menu. If the display shows [- - -], the sensor is defective or the circuit is open or shorted. • Check sensor by substitution. Be sure sensor polarity is correct. • Continuity check circuit wiring using a high quality multimeter. Be sure to maintain the correct polarity or the sensor will not work. <p>NOTE: Do NOT use a test light or other instrument; or controller damage may result.</p>
03	<p>Supply Air Temperature Sensor Failure (Check Alarm)</p> <ul style="list-style-type: none"> • Indicates a problem exists with this sensor or its wiring. The sensor is reading out-of-range; or appears to be open or shorted. • This sensor REQUIRES ice bath calibration or correct sensor grade setup. <p>NOTE: If the Supply Air sensor is the controlling sensor when it fails, the controller continues unit operation using the Return Air sensor.</p>	<ul style="list-style-type: none"> • Check the sensor by selecting it using the RET/SUP key (if necessary). If the display shows [- - -], the sensor is defective or the circuit is open or shorted. • Check sensor by substitution. Be sure sensor polarity is correct. Replacement sensor MUST be calibrated or sensor grade set. • Continuity check circuit wiring using a high quality multimeter. Be sure to maintain correct polarity or the sensor will not work. <p>NOTE: Do NOT use a test light or other instrument; or controller damage may result.</p>
04	<p>KVQ Valve Thermistor Error (Check Alarm)</p> <ul style="list-style-type: none"> • Indicates a problem exists with the thermistor or its wiring. • If the Thermistor fails, the KVQ valve actuator must be replaced. 	<ul style="list-style-type: none"> • Check the KVQ valve thermistor circuit with an ohmmeter. Good thermistor sensor should read 20,000 ohms at 20 C (78 F). • Continuity check circuit wiring using a high quality ohmmeter. Be sure to maintain the correct polarity. <p>NOTE: Do NOT use a test light or other instrument; or controller damage may result.</p>

Code	Description	Corrective Action
<p>05</p>	<p>Evaporator Coil Temperature Sensor Failure (Check Alarm)</p> <ul style="list-style-type: none"> • Indicates a problem exists with this sensor or its wiring. The sensor is reading out-of-range; or appears to be open or shorted. • Controller also generates alarm in a Pretrip test if the Evaporator Coil Sensor does not show a decrease in temperature with only the compressor running. • If alarm occurs during a Pretrip test, a dash (-) precedes the alarm code. • This sensor REQUIRES ice bath calibration or correct sensor grade setup. <p>NOTE: If the Evaporator Coil Sensor fails, the controller continues unit operation using other sensors and internal timers.</p>	<ul style="list-style-type: none"> • Check the sensor by selecting it using the View menu. If the display shows [- - -], the sensor is defective or the circuit is open or shorted. • Check sensor by substitution. Be sure sensor polarity is correct. Replacement sensor MUST be calibrated or sensor grade set. • Continuity check circuit wiring using a high quality multimeter. Be sure to maintain the correct polarity or the sensor will not work. <p>NOTE: Do NOT use a test light or other instrument; or controller damage may result.</p>
<p>06</p>	<p>Humidity Sensor Error (Check Alarm)</p> <ul style="list-style-type: none"> • Indicates a problem exists with this sensor or its wiring. The sensor is reading out-of-range; or appears to be open or shorted. 	<ul style="list-style-type: none"> • Check the sensor by selecting it using the View menu. If the display shows [- - -], the sensor is defective or the circuit is open or shorted. • Check the sensor by substitution. Be sure the sensor polarity is correct. • Continuity check circuit wiring using a high quality ohmmeter. Be sure to maintain the correct polarity. <p>NOTE: Do NOT use a test light or other instrument; or controller damage may result.</p>

Code	Description	Corrective Action
07	<p>Return Air Temperature Sensor Failure (Check Alarm)</p> <ul style="list-style-type: none"> Indicates a problem exists with this sensor or its wiring. The sensor is reading out-of-range; or appears to be open or shorted. This sensor REQUIRES ice bath calibration or correct sensor grade setup. <p>NOTE: If the Return Air sensor is the controlling sensor when it fails, the controller continues unit operation using the Supply Air sensor.</p>	<ul style="list-style-type: none"> Check the sensor by selecting it using the RET/SUP key (if necessary). If the display shows [- - -], the sensor is defective or the circuit is open or shorted. Check sensor by substitution. Be sure sensor polarity is correct. Replacement sensor MUST be calibrated or sensor grade set. Continuity check circuit wiring using a high quality multimeter. Be sure to maintain the correct polarity or the sensor will not work. <p>NOTE: Do NOT use a test light or other instrument; or controller damage may result.</p>
09	<p>Evaporator Coil Over Temperature (Shutdown Alarm — prevents unit from operating in Heat or Defrost)</p> <ul style="list-style-type: none"> Evaporator coil has exceeded high temperature limit. 	<ul style="list-style-type: none"> Check electric heater rod operation using the “AMPS HEATR” test in the Electrical Test submenu. Check evaporator coil sensor using View Menu. Check airflow over evaporator coil.
10	<p>High Pressure Cutout (Check Alarm)</p> <ul style="list-style-type: none"> Indicates the high pressure cutout switch has opened and the condition was not corrected after 5 minutes (fault condition prevented unit restart). <p>NOTE: Controller display shows “PAUSE ALM10” every 10 seconds while condenser fan operates to resolve the problem during unit shutdown.</p> <ul style="list-style-type: none"> Controller also generates alarm if high pressure cutout/restart cycle recurs 3 times within 30 minutes. 	<ul style="list-style-type: none"> Check for a dirty or restricted condenser coil. Check for correct condenser fan operation using “AMPS CFH” test in the Electrical Test submenu. Install manifold gauge set and check for correct condenser fan pressure switch operation. Check fuse F11 on the power module. Continuity check high pressure cutout switch (identified by blue cable tie) and condenser fan pressure switch (identified by red cable tie) circuit wiring using a high quality multimeter. <p>NOTE: Do NOT use a test light or other instrument; or controller damage may result.</p> <ul style="list-style-type: none"> Check for correct water cooled condenser operation (option). Check for jumper on water pressure switch connectors in sensor harness if unit is NOT equipped with a water cooled condenser (option). Check for a defective high pressure cutout switch.

Code	Description	Corrective Action
12	<p>Temperature Out-of-Range High (Check Alarm)</p> <ul style="list-style-type: none"> Indicates the control temperature has exceeded the allowable temperature and time duration above the setpoint after having been in-range. 	<ul style="list-style-type: none"> Check for an open or defective door. Check for proper setting of fresh air exchange. Perform a Full Pretrip Test to check unit operation.
13	<p>Temperature Out-of-Range Low (Check Alarm) (Chill Loads ONLY)</p> <ul style="list-style-type: none"> Indicates the control temperature has exceeded the allowable temperature and time duration below the setpoint after having been in-range. 	<ul style="list-style-type: none"> Perform a Full Pretrip Test to check unit operation.
14	<p>Defrost Terminated by Time Limit (Check Alarm)</p> <ul style="list-style-type: none"> Indicates the controller terminated a defrost cycle due to time. 	<ul style="list-style-type: none"> Check electric heater rod operation using the "AMPS HEATR" test in the Electrical Test submenu. Check for correct evaporator fan operation using the "REFRG DFRST" test in the Refrigeration Test submenu. Check evaporator coil sensor for correct operation.
16	<p>Digital Input Failure (Shutdown Alarm)</p> <ul style="list-style-type: none"> Indicates one or more digital inputs (sensor, current transformer, pressure switch, etc.) is erratic or has failed. 	<ul style="list-style-type: none"> Check for other alarms, particularly sensor alarm codes. Check controller using the Microprocessor Tester.
25	<p>Return and Supply Sensor Failure (Shutdown Alarm — setpoint at -9.9 C [14.1 F] or above) (Check Alarm — setpoint at -10 C [14 F] or below)</p> <ul style="list-style-type: none"> Indicates both the return and supply sensors have failed. 	<ul style="list-style-type: none"> Check to be sure the sensor lead connector is securely attached to the controller and the sensor harness is securely attached to the control box. Check for other sensor alarm codes, particularly codes 03 and 07. Continuity check the wiring to the temperature sensors using a wiring diagram and digital multimeter.

Code	Description	Corrective Action
37	<p>Low Refrigerant Level (Option) (Shutdown Alarm)</p> <ul style="list-style-type: none"> • Conditions indicate the refrigerant charge may be low. <p>NOTE: This function is not used on CRR units.</p>	<ul style="list-style-type: none"> • Check the refrigerant charge and correct as required.
38	<p>Real Time Clock Battery Failure (Check Alarm)</p> <ul style="list-style-type: none"> • Indicates the clock battery is under voltage or dead. <p>NOTE: The data logger may lose its time setting when unit switch is turned OFF.</p>	<ul style="list-style-type: none"> • Replace the battery. The battery is located behind a small access panel on the back of the controller. Check and reset the date/time settings as required. <p>NOTE: If the battery is changed with unit On/Off switch ON, the clock functions may not be lost. Otherwise, up to 12 hours of datalogger and hourmeter logs may be lost.</p>
41	<p>Spare Sensor 5 Failure (Option) (Check Alarm)</p> <ul style="list-style-type: none"> • Indicates a problem exists with this sensor or its wiring. The sensor is reading out-of-range; or appears to be open or shorted. • This sensor does NOT require ice bath calibration. 	<ul style="list-style-type: none"> • Check the sensor by selecting it using the View menu. If the display shows [- - -], the sensor is defective or the circuit is open or shorted. Be sure the sensor is securely attached to the connector inside the unit. • Check the sensor by substitution. Be sure the sensor polarity is correct. • Continuity check circuit wiring using a high quality multimeter. Be sure to maintain the correct polarity or the sensor will not work. <p>NOTE: Do NOT use a test light or other instrument; or controller damage may result.</p>
42	<p>Customer Configuration Alarm (Check Alarm)</p> <ul style="list-style-type: none"> • Indicates customer configuration has not been set. This alarm does not clear unless the Customer Configuration "CFG C" is set to a valid number (other than "0"). 	<ul style="list-style-type: none"> • Set the customer (and/or unit) configuration number to the setting required. <p>NOTE: The unit will operate and control temperature if the controller remains programmed to unit configuration "5000" and customer configuration "0". However, the unit will NOT operate customer specific options. See the controller identification decal for the correct unit configuration and customer configuration settings.</p>

Code	Description	Corrective Action
43	<p>Frequency Out-of-Range Low (Check Alarm)</p> <ul style="list-style-type: none"> Indicates the frequency of the supply power is low. 	<ul style="list-style-type: none"> Check the frequency of the supply power source and correct as required. If the unit is operating on generator set power supply, check generator speed. If the frequency and voltage of the power supply are correct but the controller displays 1/2 of the correct reading, replace the power module.
44	<p>Three Phase Current Imbalance (Shutdown Alarm)</p> <ul style="list-style-type: none"> Indicates the supply power current is NOT equal within limits in each of the three phases. Controller also generates alarm if phase detection circuit was unable to determine correct phase rotation; or if phase contactor ABC or CBA fails to pull in or release during a Pretrip test. 	<ul style="list-style-type: none"> Check supply power voltage on all three phases. Voltage should be present on all three phases and with 90% below or 110% above the rated voltage. Check for open circuits in the three phase power circuits to the fans, heaters and compressor. Disconnect supply power and check resistance of each heater leg. Correct open or shorted heaters. Check operation of phase contactors using the "PS1" and "PS2" tests in the Controller Test submenu. If the frequency and voltage of the power supply are correct but the controller displays 1/2 of the correct reading, replace the power module. Turn unit OFF and disconnect power supply. Disconnect plug on current transformer and check the resistance of each primary winding. Resistance for each winding should be 43 +/- 0.5 ohms. If Alarm Code 10 is also present, check for an open F11 fuse on the power module.
45	<p>Frequency Out-of-Range High (Check Alarm)</p> <ul style="list-style-type: none"> Indicates the frequency of the supply power is high. 	<ul style="list-style-type: none"> Check the frequency of the supply power source and correct as required. If the unit is operating on generator set power supply, check the generator speed. If the frequency and voltage of the power supply are correct but the controller displays 1/2 of the correct reading, replace the power module.

Code	Description	Corrective Action
46	<p>USDA 1 Sensor Failure (Option) (Check Alarm)</p> <ul style="list-style-type: none"> • Indicates a problem exists with this sensor or its wiring. The sensor is reading out-of-range; or appears to be open or shorted. • This sensor REQUIRES ice bath calibration. 	<ul style="list-style-type: none"> • Check the sensor by selecting it using the View menu. If USDA1 display shows [- - -], the sensor is defective or the circuit is open or shorted. • Check the sensor by substitution. Be sure the sensor polarity is correct. • Continuity check circuit wiring using a high quality multimeter. Be sure to maintain the correct polarity or the sensor will not work. <p>NOTE: Do NOT use a test light or other instrument; or controller damage may result.</p>
47	<p>USDA 2 Sensor Failure (Option) (Check Alarm)</p> <ul style="list-style-type: none"> • Indicates a problem exists with this sensor or its wiring. The sensor is reading out-of-range; or appears to be open or shorted. • This sensor REQUIRES ice bath calibration. 	<ul style="list-style-type: none"> • Check the sensor by selecting it using the View menu. If USDA2 display shows [- - -], the sensor is defective or the circuit is open or shorted. • Check the sensor by substitution. Be sure the sensor polarity is correct. • Continuity check circuit wiring using a high quality multimeter. Be sure to maintain the correct polarity or the sensor will not work. <p>NOTE: Do NOT use a test light or other instrument; or controller damage may result.</p>
48	<p>USDA 3 Sensor Failure (Option) (Check Alarm)</p> <ul style="list-style-type: none"> • Indicates a problem exists with this sensor or its wiring. The sensor is reading out-of-range; or appears to be open or shorted. • This sensor REQUIRES ice bath calibration. 	<ul style="list-style-type: none"> • Check the sensor by selecting it using the View menu. If USDA3 display shows [- - -], the sensor is defective or the circuit is open or shorted. • Check the sensor by substitution. Be sure the sensor polarity is correct. • Continuity check circuit wiring using a high quality multimeter. Be sure to maintain the correct polarity or the sensor will not work. <p>NOTE: Do NOT use a test light or other instrument; or controller damage may result.</p>

Code	Description	Corrective Action
49	<p>Pulp Sensor Failure (Option) (Check Alarm)</p> <ul style="list-style-type: none"> • Indicates a problem exists with this sensor or its wiring. The sensor is reading out-of-range; or appears to be open or shorted. • This sensor REQUIRES ice bath calibration. 	<ul style="list-style-type: none"> • Check the sensor by selecting it using the View menu. If PULP1 display shows [- - -], the sensor is defective or the circuit is open or shorted. • Check the sensor by substitution. Be sure the sensor polarity is correct. • Continuity check circuit wiring using a high quality multimeter. Be sure to maintain the correct polarity or the sensor will not work. <p>NOTE: Do NOT use a test light or other instrument; or controller damage may result.</p>
50	<p>Compressor Current Out-of-Range (Pretrip and Normal Operation) (Check or Shutdown Alarm)</p> <ul style="list-style-type: none"> • Indicates compressor current draw is not within the high or low limits when the compressor operates alone. • If alarm occurs during a Pretrip test, a dash (-) precedes the alarm code. • Also occurs if controller determines that the compressor motor overload opened 	<ul style="list-style-type: none"> • Check for low supply power voltage. • Check the compressor current draw with a digital multimeter. Place unit in Full Cool mode using "REFRG FC HI" in the Refrigeration Test submenu. Current draw on each leg should be within 0.3 amperes of each other. • Visually inspect the compressor motor overloads and compressor contactor. • Check the output module and related circuitry if the compressor contactor does not energize. Place unit in Full Cool mode using "REFRG FC HI" in the Refrigeration Test submenu. Then check to see that compressor output LED AC11 is ON. Check related unit wiring as necessary. • If current draw on each leg is not within 0.3 amperes of each other, check the current transformer. Turn unit OFF and disconnect power supply. Disconnect plug on current transformer and check the resistance of each primary winding. Resistance for each winding should be 43 +/- 0.5 ohms. • Check the refrigeration system for excessively high pressures that could cause high compressor current draw.

Code	Description	Corrective Action
51	<p>Unit Current Out-of-Range in COOL Mode (Check or Shutdown Alarm)</p> <ul style="list-style-type: none"> Indicates total unit current draw is not within acceptable limits when the unit is in Cool mode. <p>NOTE: This is not a Pretrip test alarm.</p>	<ul style="list-style-type: none"> Check for low supply power voltage. Check the compressor current draw with a digital multimeter. Place unit in Full Cool mode using "REFRG FC HI" in the Refrigeration Test submenu. Current draw on each leg should be within 0.2 amperes of each other. Current draw for compressor only should be 7 to 11 amperes at 480V. Check evaporator fan motor current draw using "AMPS EFH" and "AMPS EFL" in the Electrical Test submenu. Current draw for evaporator fans only should be 2 to 4.5 amperes at 480V. If current draw is high, check for obstructions to evaporator airflow. If current draw is low, check for a motor not operating. Check condenser fan motor current draw using "AMPS CFH" in the Electrical Test submenu. Current draw for condenser fan only should be 1 to 2.3 amperes at 480V. If current draw is high, check for obstructions to condenser airflow. No current draw indicates the motor is not operating. Check the evaporator fan and condenser fan motors for free rotation and proper condition. Visually inspect evaporator fan, condenser fan and compressor contactors. Check the output module and related circuitry using "REFRG FC HI" in the Refrigeration Test submenu to place the unit in Full Cool. Then confirm that output LEDs AC11, AC12 and AC14 are ON. If current draw on each leg is not within 0.2 amperes of each other during compressor current draw test, check the current transformer. Turn unit OFF and disconnect power supply. Disconnect plug on current transformer and check the resistance of each primary winding. Resistance for each winding should be 43 +/- 0.5 ohms. Check the refrigeration system for excessively high pressures.

Code	Description	Corrective Action
52	<p>KVQ Valve System Failure (Pretrip) (Check or Shutdown Alarm)</p> <ul style="list-style-type: none"> • Indicates KVQ valve does not respond to voltage pulse signal. • If alarm occurs during a Pretrip test, a dash (-) precedes the alarm code. 	<ul style="list-style-type: none"> • Perform a Full Pretrip Test to check KVQ valve operation. • Check the power module. • Check controller using the Microprocessor Tester. • Check the wiring to KVQ valve using unit wiring diagrams and a digital multimeter. <ul style="list-style-type: none"> -Disconnect KVQ valve leads and check circuit resistance. The heater (voltage pulse signal) circuit resistance should measure 20 ohms at 20 C (68 F). The thermistor circuit resistance should measure 20,000 ohms at 20 C (68 F).
53	<p>Heating Current Out-of-Range (Pretrip) (Check or Shutdown Alarm)</p> <ul style="list-style-type: none"> • Indicates total unit current draw is not within acceptable limits when the unit is in Heat mode. • If alarm occurs during a Pretrip test, a dash (-) precedes the alarm code. 	<ul style="list-style-type: none"> • Check for low supply power voltage. • Check the heater element current draw using the "REFRG HEAT" test in the Refrigeration Test submenu. Current draw should be 7 to 14.5 amperes at 480V. Current draw on each leg should be within 0.2 amperes of each other. • Visually inspect the heater contactor and evaporator fan contactors (EFH or EFL). • Check the output module and related circuitry using "REFRG HEAT" in the Refrigeration Test submenu to place the unit in Heat. Then confirm that output LEDs AC7 and AC12 (or AC8) are ON. • If current draw on each leg is not within 0.2 amperes of each other during heater current draw test, check the current transformer. Turn unit OFF and disconnect power supply. Disconnect plug on current transformer and check the resistance of each primary winding. Resistance for each winding should be 43 +/- 0.5 ohms.

Code	Description	Corrective Action
54	<p>Defrost Current Out-of-Range (Pretrip) (Check or Shutdown Alarm)</p> <ul style="list-style-type: none"> • Indicates total unit current draw is not within acceptable limits when the unit is in Defrost mode. • If alarm occurs during a Pretrip test, a dash (-) precedes the alarm code. 	<ul style="list-style-type: none"> • Check for low supply power voltage. • Check the heater element current draw using the "REFRG DFRST" test in the Refrigeration Test submenu. Current draw should be 7 to 10 amperes at 480V. Current draw on each leg should be within 0.2 amperes of each other. • Visually inspect the heater contactor. • Check the output module and related circuitry using "REFRG DFRST" in the Refrigeration Test submenu to place the unit in Heat. Then confirm that ONLY output LED AC7 is ON. • If current draw on each leg is not within 0.2 amperes of each other during heater current draw test, check the current transformer. Turn unit OFF and disconnect power supply. Disconnect plug on current transformer and check the resistance of each primary winding. Resistance for each winding should be 43 +/- 0.5 ohms.

Code	Description	Corrective Action
55	<p>High Speed Evaporator Fan Failure (Pretrip) (Check or Shutdown Alarm)</p> <ul style="list-style-type: none"> • Indicates evaporator fan current draw is not within acceptable limits when fans are in high speed. • Controller also generates alarm if cooling capacity is not sufficient. • If alarm occurs during a Pretrip test, a dash (-) precedes the alarm code. 	<ul style="list-style-type: none"> • Check for low supply power voltage. • Check high speed evaporator fan current draw using “AMPS EFH” in the Electrical Test submenu. Current draw should be 2 to 4.5 amperes at 480V for 3 fans. Current draw on each leg should be within 0.2 amperes of each other. • If current draw is high, check evaporator fan motors for free rotation and proper condition. Check direction of fan rotation (counterclockwise) as shown by directional arrows. Check for obstructions to evaporator airflow. • Visually inspect evaporator fan high speed contactor. • If contactor does not energize, check output module using “AMPS EFH” in the Electrical Test submenu. Then confirm that output LED AC12 is ON. • If current draw on each leg is not within 0.2 amperes of each other during current draw test, check the current transformer. Turn unit OFF and disconnect power supply. Disconnect plug on current transformer and check the resistance of each primary winding. Resistance for each winding should be 43 +/- 0.5 ohms. • Check refrigeration system for obstructions or low refrigerant charge.

Code	Description	Corrective Action
56	<p>Low Speed Evaporator Fan Failure (Pretrip) (Check or Shutdown Alarm)</p> <ul style="list-style-type: none"> • Indicates evaporator fan current draw is not within acceptable limits when fans are in high speed. • Controller also generates alarm if cooling capacity is not sufficient. • If alarm occurs during a Pretrip test, a dash (-) precedes the alarm code. 	<ul style="list-style-type: none"> • Check for low supply power voltage. • Check low speed evaporator fan current draw using "AMPS EFL" in the Electrical Test submenu. Current draw should be 0.8 to 2 amperes at 480V for 3 fans. Current draw on each leg should be within 0.2 amperes of each other. • If current draw is high, check evaporator fan motors for free rotation and proper condition. Check direction of fan rotation (counterclockwise) as shown by directional arrows. Check for obstructions to evaporator airflow. • Visually inspect evaporator fan low speed contactor. • If contactor does not energize, check output module using "AMPS EFH" in the Electrical Test submenu. Then confirm that output LED AC8 is ON. • If current draw on each leg is not within 0.2 amperes of each other during current draw test, check the current transformer. Turn unit OFF and disconnect power supply. Disconnect plug on current transformer and check the resistance of each primary winding. Resistance for each winding should be 43 +/- 0.5 ohms. • Check refrigeration system for obstructions or low refrigerant charge.

Code	Description	Corrective Action
57	<p>Condenser Fan Current Out-of-Range (Pretrip) (Check or Shutdown Alarm)</p> <ul style="list-style-type: none"> • Indicates condenser fan current draw is not within acceptable limits when fan is operating. • If alarm occurs during a Pretrip test, a dash (-) precedes the alarm code. 	<ul style="list-style-type: none"> • Check for low supply power voltage. • Check condenser fan current draw using “AMPS CFH” in the Electrical Test submenu. Current draw should be 1 to 2.3 amperes at 480V. Current draw on each leg should be within 0.2 amperes of each other. • If current draw is high, check condenser fan motor for free rotation and proper condition. Air should be out from the condenser fan grille. • Visually inspect condenser fan contactor. • If contactor does not energize, check output module using “AMPS CFH” in the Electrical Test submenu. Then confirm that output LED AC14 is ON. • If current draw on each leg is not within 0.2 amperes of each other during current draw test, check the current transformer. Turn unit OFF and disconnect power supply. Disconnect plug on current transformer and check the resistance of each primary winding. Resistance for each winding should be 43 +/- 0.5 ohms.
58	<p>Sensor Calibration Failure (Pretrip) (Check or Shutdown Alarm)</p> <ul style="list-style-type: none"> • Indicates the Return Air, Supply Air and Evaporator Coil sensor temperatures are not within acceptable limits after the evaporator fans have been ON for a specified time. • If alarm occurs during a Pretrip test, a dash (-) precedes the alarm code. 	<ul style="list-style-type: none"> • Check for other sensor alarm codes, particularly codes 03, 05 and/or 07. • Check for obstructions to evaporator airflow. • Check sensor grade calibrations. Compare controller sensor grade setting in View Menu with with grade shown on sensor identification decals. • Check operation of evaporator fans using “AMPS EFH” in the Electrical Test submenu. Then visually inspect fans for proper rotation and operation.

Code	Description	Corrective Action
59	<p>μP-A+ Datalogger Full (Check Alarm)</p> <ul style="list-style-type: none"> Indicates datalogger is full. 	<ul style="list-style-type: none"> Enter a Start of Trip to place a marker in the controller's data logger memory. Send a Header to controller's data logger memory.
60	<p>Global Datalogger Full (Check Alarm)</p> <ul style="list-style-type: none"> Indicates datalogger is full. 	<ul style="list-style-type: none"> Enter a Start of Trip to place a marker in the controller's data logger memory. Send a Header to controller's data logger memory.
61	<p>Real Time Clock Invalid (Check Alarm)</p> <ul style="list-style-type: none"> Indicates real time clock has been corrupted (due to faulty battery, static discharge, etc.). Up to 12 hours of datalogger and hourmeter logs have been lost. 	<ul style="list-style-type: none"> Check the battery voltage using "CLKV" in the View menu. Replace the battery if voltage is less than 3.3 V. Then reset the date/time settings. If real time clock can NOT be reset, replace the controller.
63	<p>Bypass (Warm Gas) Valve Circuit Failure (Pretrip) (Check Alarm)</p> <ul style="list-style-type: none"> Indicates a problem with the Bypass Valve or its wiring. If alarm occurs during a Pretrip test, a dash (-) precedes the alarm code. <p>NOTE: This valve is not used on CRR units.</p>	<ul style="list-style-type: none"> Energize and de-energize the bypass valve using "BVS" in the Controller Test submenu. Confirm by sound that the valve energizes and de-energizes. If the valve does not operate, check the valve coil for continuity using a high quality multimeter. Check the circuit wiring for continuity using a high quality multimeter and a wiring diagram. <p>NOTE: Do NOT use a test light or other instrument; or controller damage may result.</p>

Code	Description	Corrective Action
64	<p>Pretrip Preconditioning Failure (Check Alarm)</p> <ul style="list-style-type: none"> Indicates a heating or cooling problem; Pretrip Test pre-cooling or pre-heating of the container was aborted or was not completed in the time allowed. Indicates a Pretrip Test was initiated on a loaded container. Indicates a possible liquid injection system failure if alarm 82 is also recorded. If alarm occurs during a Pretrip test, a dash (-) precedes the alarm code. 	<ul style="list-style-type: none"> Check the container to be sure it is not loaded. Check unit cooling and heating operation. Check the liquid injection system.
65	<p>Datalog Queuing Error (Check Alarm)</p> <ul style="list-style-type: none"> Indicates an error occurred in the datalogger. 	<ul style="list-style-type: none"> Check operation of the real time clock using the "YEAR", "MONTH", "DAY" and "TIME" displays in the View menu. Check for the presence of Alarm Code 61. Check real time clock battery voltage using "CLKV" in View menu. Replace battery if voltage is less than 3.3 V.
69	<p>Dehumidify Valve Circuit Failure (Option) (Pretrip) (Check Alarm)</p> <ul style="list-style-type: none"> Indicates a problem with the Dehumidify Valve or its wiring. If alarm occurs during a Pretrip test, a dash (-) precedes the alarm code. 	<ul style="list-style-type: none"> Energize and de-energize the dehumidify valve using "DEHUM" in the Controller Test submenu. Confirm by sound that the valve energizes and de-energizes. If the valve does not operate, check the valve coil for continuity using a high quality multimeter. Check the circuit wiring for continuity using a high quality multimeter and a wiring diagram. <p>NOTE: Do NOT use a test light or other instrument; or controller damage may result.</p>
70	<p>Hourmeter Alarm (Check Alarm)</p> <ul style="list-style-type: none"> Indicates a problem with one or more of the controller's internal hourmeters. 	<ul style="list-style-type: none"> The hourmeter exceeded 99,999. Reset the hourmeter to 0.

Code	Description	Corrective Action
71	<p>User Hourmeter 1 Expired (Check Alarm)</p> <ul style="list-style-type: none"> Indicates time set on a user hourmeter has expired. 	<ul style="list-style-type: none"> Check the hourmeter type and proceed according to company requirements. Reset the hourmeter if required.
72	<p>User Hourmeter 2 Expired (Check Alarm)</p> <ul style="list-style-type: none"> Indicates time set on a user hourmeter has expired. 	<ul style="list-style-type: none"> Check the hourmeter type and proceed according to company requirements. Reset the hourmeter if required.
73	<p>User Hourmeter 3 Expired (Check Alarm)</p> <ul style="list-style-type: none"> Indicates time set on a user hourmeter has expired. 	<ul style="list-style-type: none"> Check the hourmeter type and proceed according to company requirements. Reset the hourmeter if required.
74	<p>User Hourmeter 4 Expired (Check Alarm)</p> <ul style="list-style-type: none"> Indicates time set on a user hourmeter has expired. 	<ul style="list-style-type: none"> Check the hourmeter type and proceed according to company requirements. Reset the hourmeter if required.
79	<p>Data Overflow (Check Alarm)</p> <ul style="list-style-type: none"> Indicates an event that occurred was not recorded by the datalogger. 	<ul style="list-style-type: none"> No corrective action possible. This alarm only serves to indicate an event was not recorded in the datalogger.
81	<p>Compressor Temperature Sensor Failure (Check Alarm)</p> <ul style="list-style-type: none"> Indicates a problem exists with this sensor or its wiring. The sensor is reading out-of-range; or appears to be open or shorted. 	<ul style="list-style-type: none"> Check the sensor by selecting it using the View menu. If the display shows [- - -], the sensor is defective or the circuit is open or shorted. Check the sensor by substitution. Be sure the sensor polarity is correct. Continuity check circuit wiring using a high quality multimeter. Be sure to maintain the correct polarity or the sensor will not work. <p>NOTE: Do NOT use a test light or other instrument; or controller damage may result.</p>

Code	Description	Corrective Action
<p>82</p>	<p>Compressor Over Temperature (Check Alarm)</p> <ul style="list-style-type: none"> Indicates compressor temperature sensor has detected a high compressor temperature condition and the condition was not corrected after 5 minutes (fault condition prevented unit restart). <p>NOTE: Controller display shows “PAUSE ALM82” every 10 seconds while the condenser fan operates to resolve the problem during unit shutdown.</p> <ul style="list-style-type: none"> Controller also generates alarm if high compressor temperature/restart cycle recurs 3 times within 30 minutes. 	<ul style="list-style-type: none"> Check operation of the liquid injection valve using “LIV” in the Controller Test submenu. Check refrigeration system for plugged filter drier, plugged in-line filter, low or high side obstructions or closed liquid line service valve.
<p>85</p>	<p>Compressor Current Out-of-Range (Check or Shutdown Alarm)</p> <ul style="list-style-type: none"> Indicates compressor motor has failed to start. 	<ul style="list-style-type: none"> Check for low supply power voltage. Check the compressor current draw with a digital multimeter. Place unit in Full Cool mode using “REFRG FC HI” in the Refrigeration Test submenu. Current draw of the compressor only should be 7 to 11 amperes at 480V. Current draw on each leg should be within 0.3 amperes of each other. Visually inspect compressor motor contactor. If compressor contactor does not energize, check output module and related circuits by using “REFRG FC HI” in the Refrigeration Test submenu to place the unit in Cool. Then confirm that output LED AC11 is ON. If current draw on each leg is not within 0.3 amperes of each other during compressor current draw test, check the current transformer. Turn unit OFF and disconnect power supply. Disconnect plug on current transformer and check the resistance of each primary winding. Resistance for each winding should be 43 +/- 0.5 ohms. Check the refrigeration system for excessively high pressures. Check the compressor for proper operation.

Code	Description	Corrective Action
92	<p>Condenser Fan Sensor Failure (Check Alarm)</p> <ul style="list-style-type: none"> Indicates a problem exists with this sensor or its wiring. The sensor is reading out-of-range; or appears to be open or shorted. This alarm occurs only if the unit is using the sensor to control condenser fan operation. 	<ul style="list-style-type: none"> Check the sensor by selecting it using the View menu. If the display shows [- - -], the sensor is defective or the circuit is open or shorted. Check the sensor by substitution. Be sure the sensor polarity is correct. Continuity check circuit wiring using a high quality multimeter. Be sure to maintain the correct polarity or the sensor will not work. <p>NOTE: Do NOT use a test light or other instrument; or controller damage may result.</p>
97	<p>Loss of Communications with Output Module (Shutdown Alarm)</p> <ul style="list-style-type: none"> Indicates a communications link between the controller and output module is not functioning. 	<ul style="list-style-type: none"> Check the RXD and TXD LEDs at the top of the output module. These LEDs should alternately flash on a continuous basis to indicate a good communications link. Check the cable from the controller to the thermo bus tap. Check the cable from the thermo bus tap to the output module. Check thermo bus tap for can terminator resistor R4. Check controller using the Microprocessor Tester. Replace the Output Module.

5

Electrical Maintenance

Unit Wiring

Inspect unit wiring, wire harnesses, and the controller during pre-trip inspection and every 1,000 operating hours to protect against unit malfunctions due to open or short circuits. Look for loose, chaffed or broken wires on the unit; open or short circuits and damaged components on the controller printed circuit board.

Inspect electrical contactor points for pitting or corrosion every 1,000 operating hours. Repair or replace as necessary.

Auxiliary Battery and Battery Charger (Option)

An auxiliary battery is available to operate the μ P-D controller when the unit is not connected to a 460-380 Vac power supply. Pressing the controller SELECT key provides battery power to the controller for 5 minutes to allow setpoint adjustment or a download of the datalogger. The battery box is mounted in the cord storage compartment.

Check the battery voltage during the unit pretrip inspection. The battery is a 12 Vdc, 7 or 12 Amp hour Gel Cell. The voltage should be 12.4 to 12.7 Vdc. If the voltage is 11.5 to 12.39 Vdc, the battery must be charged. Charge the battery until the current into the battery at 13.6 Vdc @ 25 C (77 F) is less than 10 mA. If the voltage is less than 11.5 Vdc, replace the battery.

NOTE: The battery charging current MUST NOT exceed 800 ma.

If the battery is undercharged, check the battery charger for proper operation.

High Pressure Cutout Switch

The high pressure cutout is located on the compressor discharge manifold. If the discharge pressure rises above 2410 +/- 70 kPa, 24.1 +/- 0.7 bar, 350 +/- 10 psig (2240 +/- 70 kPa, 22.4 +/- 0.7 bar, 325 +/- 10 psig on CRR-20-63); the switch opens the R51A circuit:

- The compressor and evaporator fans STOP immediately.
- The condenser fan will continue to operate.
- After 5 minutes, the controller attempts to restart the compressor.

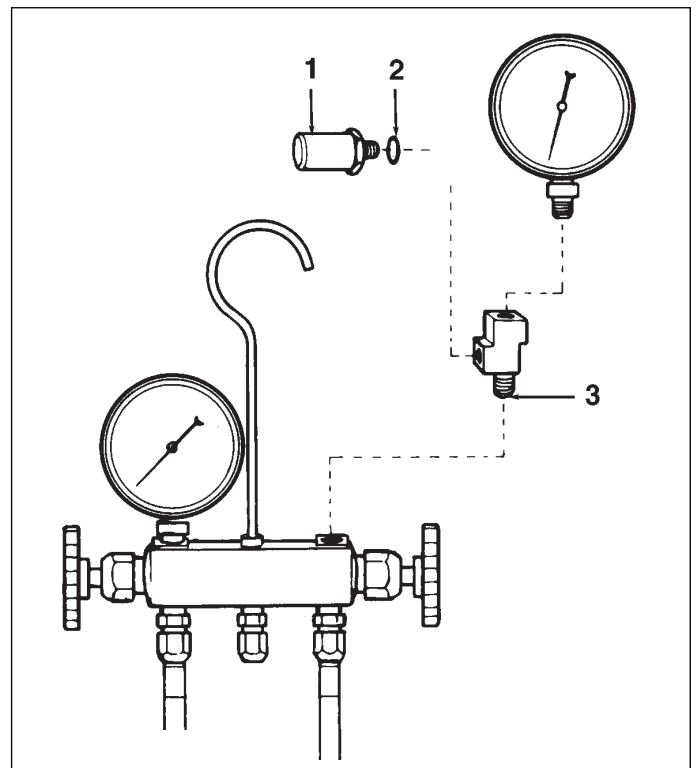

High Pressure Cutout Manifold

1. Relief Valve, P/N 66-6543
2. O-ring, P/N 33-1015
3. Adapter Tee (Weather Head No. 552X3)

- If the compressor restarts and operates for 10 minutes without an overload condition, no alarm is recorded.
- If the overload still exists after 5 minutes, the controller turns the Alarm LED ON. Also, if the overload condition occurs 3 times within 30 minutes, an alarm is recorded. Pressing the ALARM key on the controller will cause alarm code 10 (High Refrigerant Cutout) to appear on the right display.
- Unit restarts when the overload condition is corrected (reset) as long as power is available.

To test the switch, rework a gauge manifold per “High Pressure Cutout Manifold” illustration.

High Pressure Cutout Manifold

1. Connect the manifold gauge to the compressor discharge service valve with a heavy duty, black jacketed thick wall #HCA 144 hose with 6024 kPa, 60.24 bar, 900 psig working pressure rating.
2. Operate the unit in Cool by performing an REFRG/FC HI (full cool with high speed evaporator fan) test from the Test Menu of the μ P-D controller.
3. Raise the discharge pressure of the compressor by blocking the condenser coil airflow. Temporarily cover the compressor compartment, control box and power cord storage compartment with cardboard to reduce condenser coil airflow. This should increase the discharge pressure enough to cause the switch to open. When the switch opens:
 - The Alarm LED should turn ON.
 - The compressor and evaporator fans should STOP immediately.
 - The condenser fan should continue to operate.

NOTE: The discharge pressure should never be allowed to exceed 2,760 kPa, 27.6 bar, 400 psig.

4. Be sure to remove the cardboard installed in step 3.

NOTE: To clear the HPCO alarm, press the ALARM key on the controller. Press the DOWN key until ENTER flashes in the left display. Then press the ENTER key. The Alarm LED should turn OFF and the unit re-start.

WARNING: When alarm codes are cleared by pressing the ENTER key, the unit will start automatically.

If the HPCO switch fails to stop compressor operation, replace the switch and repeat steps 1 through 4.

Condenser Fan and Evaporator Fan Rotation

Condenser Fan

Check for proper condenser fan rotation by placing a small cloth or sheet of paper against the condenser fan grille on the front of the unit. Proper rotation will blow the cloth or paper away from the grille. Improper rotation will hold the cloth or paper against the grille.

NOTE: If unit operating conditions do not require condenser fan operation, check the condenser fan rotation by performing an AMPS/CFH (high speed condenser fan) test from the Test Menu of the μ P-D controller.

If the condenser fan is rotating backwards, refer to the unit wiring diagram to correct fan motor wiring at the fan motor junction box or condenser fan contactor. To correct improper fan rotation, reverse any two fan power cord leads at the condenser fan contactor (disconnect power supply before reversing leads). DO NOT move the CH ground wire.

Evaporator Fans

Visually inspect the evaporator fan blades for proper rotation. Arrows located on the underside of the fan deck indicate the correct direction of rotation.

NOTE: Check both High and Low Speed evaporator fan rotation by performing an AMPS/EFH (high speed evaporator fan) test and AMPS/EFL (low speed evaporator fan) test from the Test Menu of the μ P-D controller.

If an evaporator fans rotate backwards on one or both speeds, refer to the unit wiring diagram to correct motor wiring at the fan motor junction box or evaporator fan contactor (disconnect power supply before reversing leads). (DO NOT move the ground wire which is labeled CH.)

NOTE: Evaporator fan motor wires EF1, EF2 and EF3 are used on LOW SPEED fan operation. Wires EF11, EF12 and EF13 are used on HIGH SPEED fan operation.

NOTE: To diagnose the controller phase selection system if both the condenser fan and evaporator fans are rotating backwards, see the Diagnosis Manual for Thermoguard μ P-D Microprocessor Controller, TK 41230.

Electric Heaters

Six electric heater elements are located underneath the evaporator coil. If a heater element is suspected of malfunctioning, inspect the connections:

- If the connections appear correct and secure, isolate and check the resistance of each individual heater element by disconnecting it from the circuit.
- Check resistance with an ohmmeter.

NOTE: When repairing heater connections, protect the new connections from the ingress of moisture with heat shrink tubing. All heaters should be secured to prevent contact with sharp metal edges.

6 Refrigeration Maintenance and Service Operations

NOTE: The following procedures involve servicing the refrigeration system. Some of these service procedures are regulated by Federal, and in some cases, by State and Local laws.

All regulated refrigeration service procedures must be performed by an EPA certified technician, using approved equipment and complying with all Federal, State and Local laws.

NOTE: It is generally good practice to replace the filter drier whenever the high side is opened or when the low side is opened for an extended period of time.

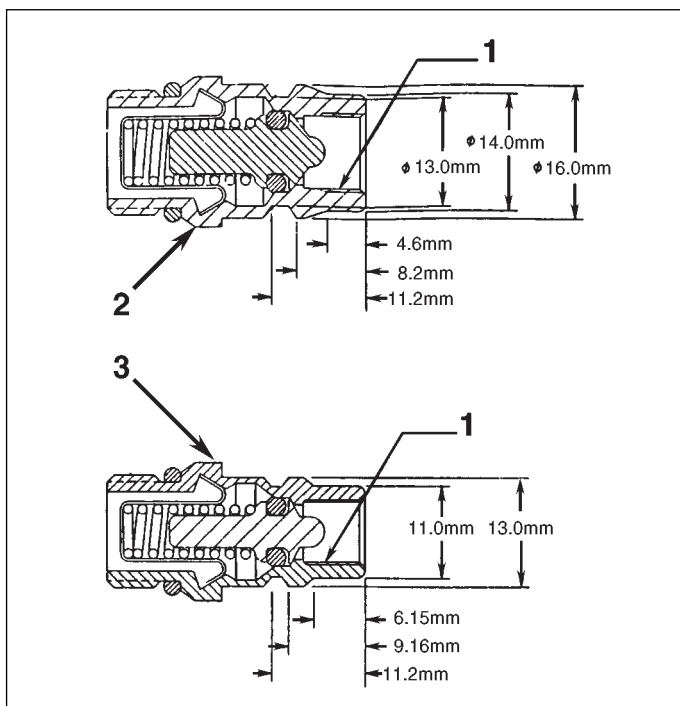

Service Fittings Specifications

1. Internal Threads for Cap
2. High Pressure Fitting
3. Low Pressure Fitting

Service Tools

CAUTION: When servicing Thermo King R-134a refrigeration systems, use only those service tools (i.e., vacuum pump, refrigerant recovery equipment, gauge hoses, and gauge manifold set) certified for and dedicated to R-134a refrigerant and Polyol Ester based compressor oils. Residual non-HFC refrigerants or non-Ester based oils will contaminate HFC systems.

Unit Service Fittings

Special fittings are used on R-134a systems to prevent mixing of non-HFC refrigerants in R-134a units. These fittings are located in three places on CRR refrigeration systems:

- Low side near the compressor suction service valve (or suction adapter),
- High side near the compressor discharge service valve (or discharge manifold),
- High side near the receiver tank outlet valve.

Leak Detection

Leaks can be detected with the use of soap bubbles and with Halogen leak detectors such as model H10G, P/N 204-712 or model H10N, P/N 204-756 (portable).

Gauge Manifold Set

A new gauge manifold set (P/N 204-758) should be dedicated for use with R-134a only. Gauge hoses should also be dedicated to R-134a.

Vacuum Pump

A two-stage (P/N 204-725), three-stage or five-stage pump is recommended for evacuation. Purging the system with dry nitrogen is recommended before evacuation. Because residual refrigerant may be present in used vacuum pumps, a new vacuum pump should be used and dedicated strictly as an R-134a refrigerant pump. Use only recommended vacuum pump oils and change oil after every major evacuation.

Because vacuum pump oils are highly refined to obtain low vacuums, failure to follow these recommendations may result in acidic conditions that will destroy the pump.

System Cleanup

Cleanup devices such as suction line filters and compressor oil filters may be used if they are properly cleaned and new filters and cartridges are used. All standard petroleum and synthetic compressor oils must be removed to prevent the contamination of R-134a systems.

Refrigerant Recovery

Use only refrigerant recovery equipment approved for and dedicated to R-134a recovery.

Compressor Oil Acid Test

Perform an oil acid test (oil test kit P/N 203-457) whenever a unit has a substantial refrigerant loss, a noisy compressor or dark/dirty oil.

Compressor Discharge and Suction Service Valves

The discharge and suction valves isolate the compressor from the high and low sides of the refrigeration system for system diagnosis, service and repair.

NOTE: *The only maintenance possible on the discharge or suction service valve is to periodically tighten the packing nut or to replace the packing. The valves are a permanently assembled unit and must be replaced in total if defective.*

- Back Seated: Normal operation position.
- Open to Service Port: Position for servicing.
- Front Seated: To check or remove compressor.

WARNING: *Do not start unit with discharge valve in FRONT SEATED position.*

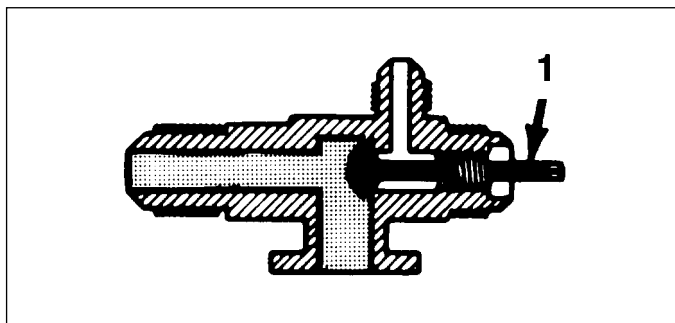

Service Valve Back Seated

1. Full Counterclockwise

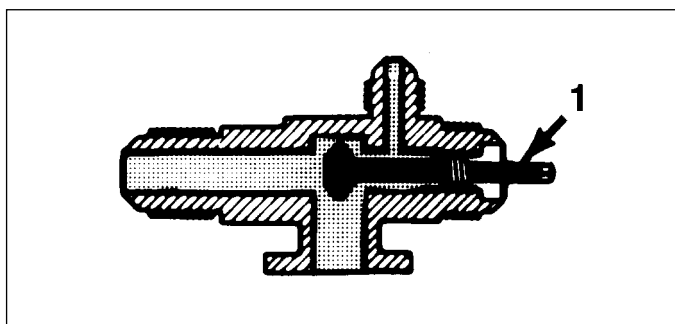

Service Valve Open to Port

1. 1/2 Turn In

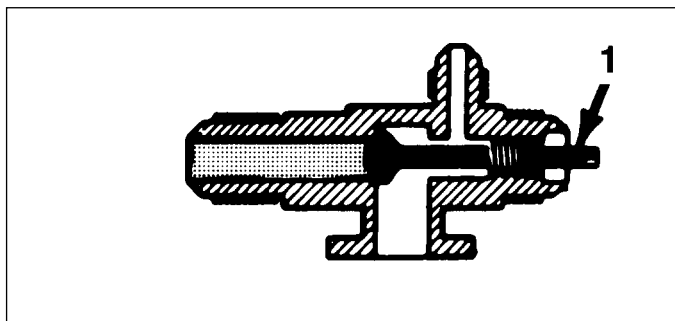

Service Valve Front Seated

1. Full Clockwise

Gauge Manifold Valve Positions

The gauges indicate low and high side pressures. Operate one or both hand valves to perform the different service operations.

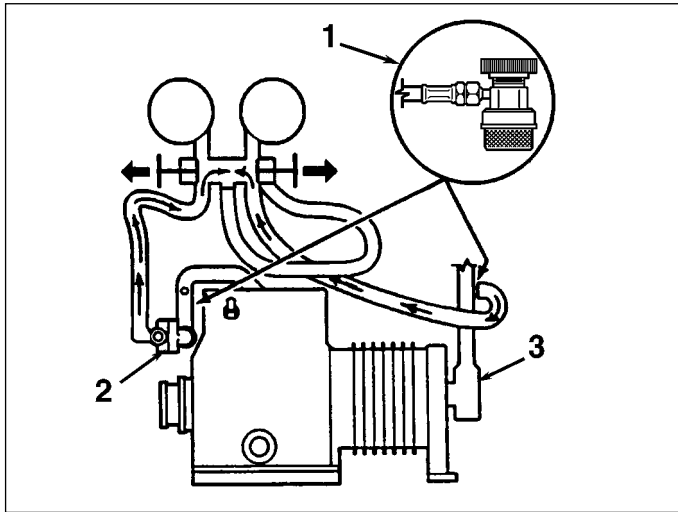

Balancing the Pressure

1. Quick Disconnect Access Valve
2. Discharge Service Valve (DSV)
3. Suction Service Valve (SSV)

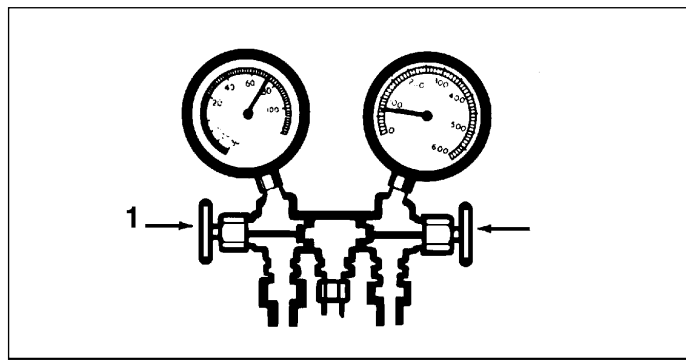

Gauge Manifold Closed to Center Port

1. Close Hand Valves

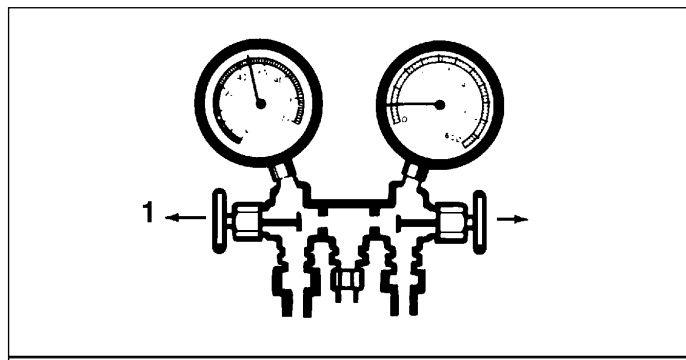

Gauge Manifold Open to Center Port

1. Open Hand Valves

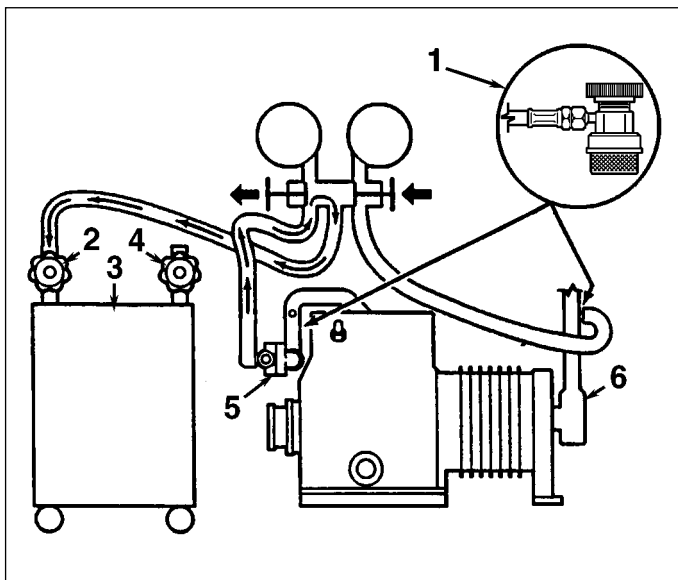

Removing Refrigerant

1. Quick Disconnect Access Valve
2. In
3. Reclaimer
4. Out
5. Discharge Service Valve (DSV)
6. Suction Service Valve (SSV)

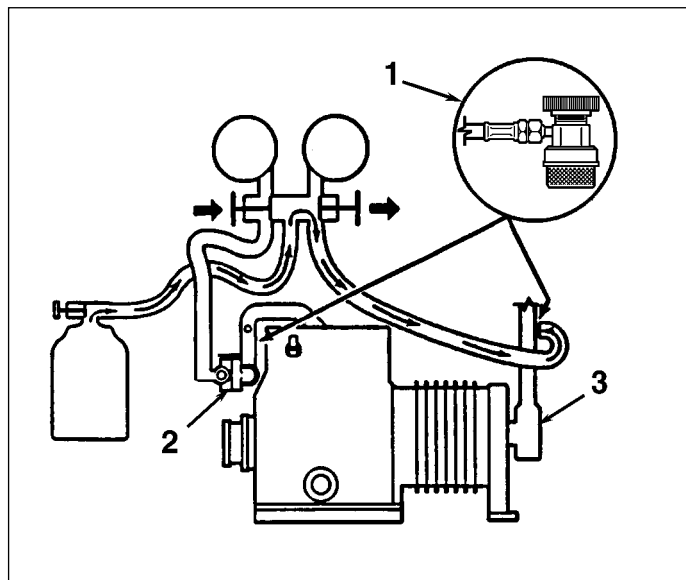

Charging the System

1. Quick Disconnect Access Valve
2. Discharge Service Valve (DSV)
3. Suction Service Valve (SSV)

Gauge Manifold Set (With Low Loss Fittings) Attachment And Purging

Thermo King recommends the use of access valves or self-sealing, quick disconnect fittings whenever possible to limit the loss of refrigerant into the atmosphere. A separate gauge manifold set with low loss fittings (P/N 204-758) should be dedicated for use with R-134a only. Gauge hoses should also be dedicated to R-134a.

NOTE: When any of these devices are used, carefully check to ensure that access connections are functioning properly.

Gauge Manifold Set Installation

NOTE: The following procedure purges the gauge hoses and must be followed when using new gauges or hoses for the first time. The system should be operating on Cool (10 psig [69 kPa] or greater suction pressure) when using this procedure to purge the low side hose. Gauge hoses may be removed and re-installed without additional purging so long as a slight positive pressure remains in the manifold and lines when removed from the unit.

1. Inspect gauge manifold for proper hose and fitting connections.
2. Clean dirt and moisture from around service ports.
3. Remove small service port caps from suction and discharge service fittings. Save and re-use the caps and sealing washers or gaskets.
4. Rotate both hose coupler hand wheels counterclockwise to back the stem out of the high and low hose fittings. Then attach low hose (compound gauge) to the suction line valve port.
5. With 69 kPa, 0.69 bar, 10 psig or greater pressure in the low side (unit operating on Cool), open the suction service manifold hand valve fully. Then rotate the suction hose fitting hand wheel clockwise to open (depress) the suction line port valve to the low hose.
6. Slowly screw a 1/2 inch ACME fitting into the low loss fitting on the manifold's service (center) line to purge the suction and service hoses. Remove ACME fitting after purging.

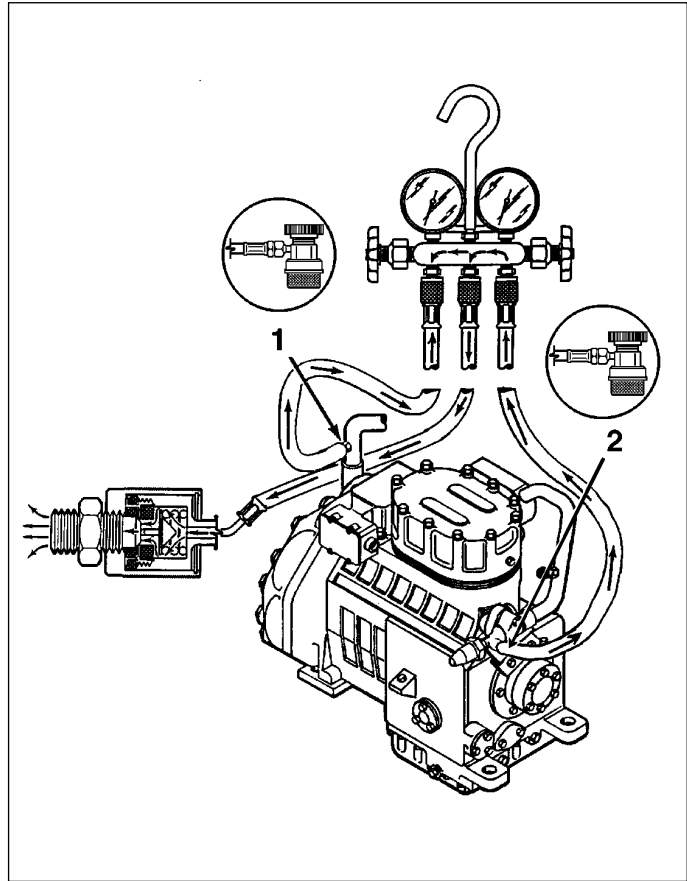

Purging Gauge Manifold

1. Suction Connection
2. Discharge Connection

7. Close the suction service manifold hand valve fully to center port.
8. Attach high side hose (pressure gauge) to the discharge service line port.
9. Open discharge service manifold hand valve fully. Then rotate discharge fitting hand wheel clockwise to open (depress) discharge line port valve to the high hose.
10. Slowly screw a 1/2 inch ACME fitting into the manifold's service (center) line to purge the high and service hoses. Remove ACME fitting after purging.
11. Close discharge service manifold hand valve fully to center port. You are now ready to use the gauge manifold to check system pressures or perform MOST service procedures.

NOTE: *These gauges may be removed and reinstalled without additional purging so long as a slight positive pressure remains in the manifold and hoses when removed from the unit.*

Gauge Manifold Set Removal

NOTE: *To ensure minimum refrigerant release to the atmosphere, THE SYSTEM SHOULD BE RUNNING. However, this is not possible in all cases, but the same procedure should be followed.*

1. Rotate discharge hose fitting hand wheel counterclockwise to withdraw the fitting stem from the discharge line port valve. Then open both service manifold valves to center port.
2. Close the receiver tank outlet valve and pump down the low side. Then turn the unit OFF.
3. Rotate the discharge fitting hand wheel counterclockwise to depress the port valve stem to equalize pressure at 21 kPa, 0.21 bar, 3 psig.
4. Rotate both coupler hand wheels counterclockwise to close (seal) the valve port stems to the high and low hoses.
5. Remove the gauge lines from the suction and discharge service fittings and cap the service ports.
6. Back seat receiver tank outlet valve and cap valve stem.
7. Secure all manifold lines to manifold hose anchors when the manifold is not in use.

Checking Compressor Oil

CAUTION:

- **Use ONLY Polyol Ester based refrigeration compressor oil, P/N 203-433.**
- **DO NOT mix Polyol Ester based and standard synthetic compressor oils.**
- **Rubber gloves are recommended when handling Ester based compressor oil.**
- **Keep Polyol Ester based compressor oil in tightly sealed containers. If Ester based oil becomes contaminated with moisture or standard oils, dispose of properly — DO NOT USE!**

The compressor oil should be checked during pretrip inspections and when there is evidence of oil loss (oil leaks) or when components in the refrigeration system have been removed for service or replacement.

To check compressor oil level with an ambient air temperature above 10 C (50 F)

Install gauge manifold on the compressor. Operate the unit on COOL with a 138 kPa, 1.38 bar, 20 psig minimum suction pressure and a 689 kPa, 6.89 bar, 100 psig discharge pressure for 15 minutes or more. After the unit has maintained the above conditions for 15 minutes, observe the compressor oil level. The oil should be 1/2 to 3/4 up in the sight glass.

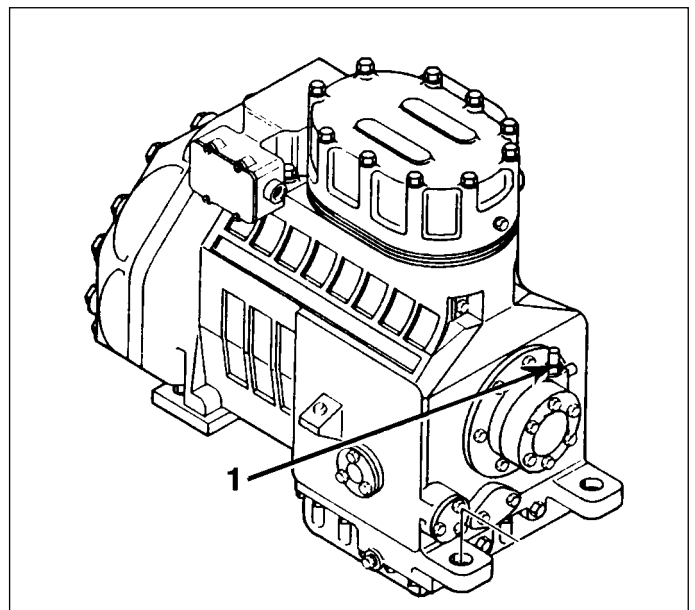

Adjusting Compressor Oil Level

1. Add and Remove Compressor Oil at the Compressor Oil Fitting

To check compressor oil level with an ambient air temperature below 10 C (50 F)

With the evaporator temperature below 10 C (50 F), initiate a Manual Defrost to operate the unit through a complete DEFROST CYCLE. After completing the defrost cycle, operate the unit on COOL for a few minutes. After 2 to 3 minutes, observe the oil level. The oil should be 1/2 to 3/4 up in the sight glass.

If the container is empty, you can operate the unit on the heat cycle instead of the defrost cycle.

Adding Compressor Oil

1. Install gauge manifold set (refer to "Gauge Manifold Set Attachment and Purging"). Pump the compressor down (refer to "Low Side Pump Down").
2. After stopping the compressor, adjust the low side pressure to to 21 kPa, 0.21 bar, 3 psig using the service gauge set. (Pressure measured at the suction line service port.)
3. Remove the cap from oil pressure fitting on oil pump.
4. Using a commercial hand pump, force oil in through the oil pressure fitting. Slowly add oil and allow 5 to 10 minutes for the oil to flow down through the compressor into the sump. Add Polyol Ester oil, P/N 203-433 ONLY!
5. When the compressor oil sight glass is 1/2 to 3/4 full, remove hand pump and replace the cap on the oil pressure fitting.
6. Open the compressor suction service valve (or receiver tank outlet valve) and operate the unit. Recheck the refrigerant charge level and the oil level before returning the unit to service.

Removing Excess Compressor Oil

1. Install an access valve actuator on the oil pressure fitting.
2. Operate the unit and remove oil while watching the level in the compressor sight glass.

NOTE: Heavy foaming of the oil as it leaves the compressor may indicate an excess of refrigerant in the oil. Remove the access valve actuator and operate the system for 15 minutes to ensure warm sump. Then recheck the oil level.

3. When the compressor oil sight glass is 1/2 to 3/4 full, remove access valve and replace the cap on the oil pressure fitting.
4. Operate the unit and recheck the refrigerant charge level and the oil level before returning the unit to service.

Refrigerant Leak Test Procedure

Use a reliable Halogen leak detector such as model H10G, P/N 204-712 or 204-756 (portable), to leak test the refrigeration system. Inspect carefully for signs of compressor oil leakage which is the first sign of a leak in the refrigeration system.

NOTE: Due to environmental concerns and personal safety, the use of a Halide torch is no longer recommended.

If refrigerant has leaked or been removed from the unit:

1. Check entire system for possible component damage and refrigerant oil loss.
2. Attach gauge manifold set (refer to "Gauge Manifold Set Attachment and Purging" for proper procedures).
3. Attach refrigerant bottle charging hose to center of gauge manifold and purge charging hose of air.
4. Pressurize the system with refrigerant (GAS ONLY) until 345 kPa, 3.45 bar, 50 psig vapor pressure is achieved.
5. Leak check the system with an electronic leak detector to inspect all joints and connections. (Use soap solution as an alternative test component.)
If no leaks are found but the system has lost its refrigerant charge, proceed to the next step.
6. Close both hand valves on gauge manifold (front seated).
7. Disconnect the refrigerant charging hose.

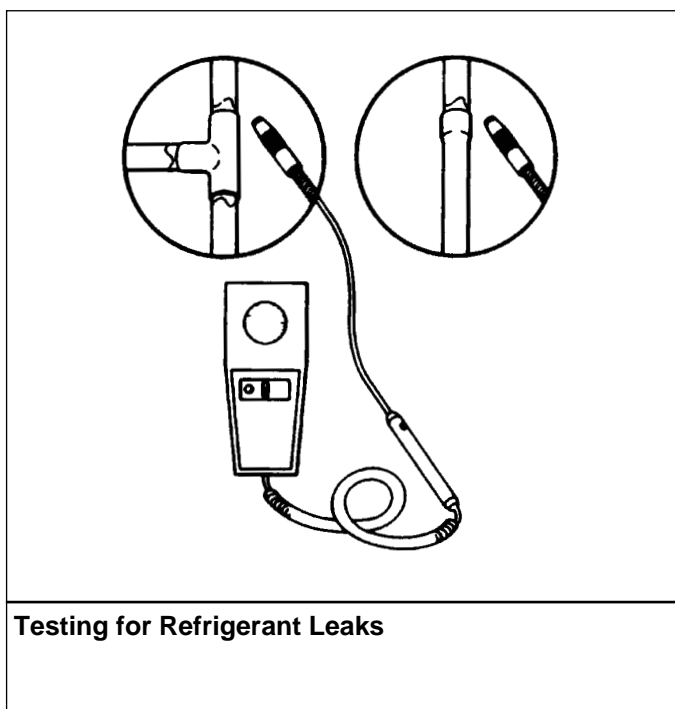

Testing for Refrigerant Leaks

8. Connect the charging hose to a source of nitrogen. Adjust the pressure regulator to 1380 kPa, 13.80 bar, 200 psig. See "Using Pressurized Nitrogen" in this manual chapter.

CAUTION: Nitrogen (N₂) is under 15,170 kPa, 151.70 bar, 2200 psig pressure in a full cylinder at 21 C (70 F). DO NOT use oxygen, acetylene or any other type of pressurized gas in the system.

9. Pressurize the system with nitrogen to 1380 kPa, 13.80 bar, 200 psig.
10. Close the supply valve on the nitrogen bottle.
11. Use an electronic leak tester to inspect all joints and connections. (Use a soap solution as an alternative test component.)

NOTE: If system leakage is indicated, loosen supply line hose fittings to release pressure. Repair leakage condition.

12. If system repair is necessary, recheck system after repairs are completed.

Low Side Pump Down

1. Install the gauge manifold on the compressor.
2. Set the controller setpoint temperature well below the return air temperature and operate the unit in the Cool mode until the temperature stabilizes (at least 5 minutes).
3. Close the receiver tank outlet valve. Allow the unit to operate until it reaches -15 to -40 kPa, -0.15 to -0.40 bar, 5 to 11 in. vacuum on the suction pressure gauge (3-5 minutes). Then shut the unit down manually with the On/Off switch.

CAUTION: Never open the low side to the atmosphere while it is in a vacuum. Air and moisture will be drawn in and contaminate the refrigerant system.

4. To place the unit back in service, open the receiver tank outlet valve and turn the On/Off switch ON.

Refrigerant Charge

The refrigerant charge should be checked during pretrip and routine maintenance inspections. A low charge of refrigerant will cause the container temperature to rise due to the lack of liquid refrigerant at the expansion valve even though the unit is operating in a cooling mode. The refrigerant charge can be checked by inspecting the receiver tank sight glass.

NOTE: See "Receiver Tank Sight Glass" under Unit Instruments in the Operating Instructions chapter for information about checking the moisture indicator in the sight glass.

Unit Refrigerant Charge:

- Standard receiver: 4.9 kg (10.8 lb) of R-134a.
- Water-cooled condenser-receiver: 5.45 kg (12.0 lb) of R-134a.

Checking the Refrigerant Charge

1. Inspect the receiver tank sight glasses with the unit operating in COOL.
 - a. Standard Receiver Tank:
 - If the balls FLOAT in the sight glass at any time, R-134a charge is OK.
 - If the balls DO NOT FLOAT, R-134a charge may be low.
 - b. Water-cooled Condenser-receiver Tank with two sight glasses (Before 8/99):
 - If the BOTTOM sight glass balls FLOAT, the R-134a charge level is OK.
 - If the BOTTOM sight glass balls DO NOT FLOAT, R-134a charge level may be low. Go to step 3.

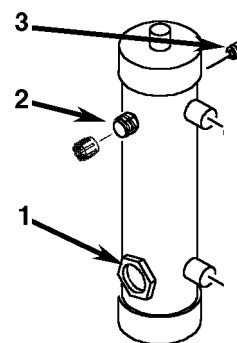

Standard Receiver Tank

1. Sight Glass: Refrigerant charge is OK if ball FLOATS at any time
2. Service Fitting
3. Fusible Plug

- c. Water-cooled Condenser-receiver Tank with one sight glass (After 8/99):
- If the balls FLOAT in the sight glass at any time, R-134a charge is OK.
 - If the balls DO NOT FLOAT, R-134a charge may be low.
3. Operate the unit on MAXIMUM COOL for 5 minutes. If necessary, place the unit in COOL using the REFRG/FC HI (cool with high speed evaporator fans) command in the controller Test menu.
- a. Standard Receiver Tank:
- If the balls DO NOT FLOAT in the sight glass at any time, the R-134a charge is low.
 - If the balls FLOAT ALL THE WAY TO TOP of sight glass, the unit is overcharged.
- b. Water-cooled Condenser-receiver Tank with two sight glasses (Before 8/99):
- If the BOTTOM sight glass balls DO NOT FLOAT at any time, the R-134a charge is low.
 - If the TOP sight glass ball FLOATS ALL THE WAY TO TOP of sight glass, the unit is overcharged.

- c. Water-cooled Condenser-receiver Tank with one sight glass (After 8/99):
- If the balls DO NOT FLOAT in the sight glass at any time, the R-134a charge is low.
 - If the balls FLOAT ALL THE WAY TO TOP of sight glass, the unit is overcharged.

NOTE: *Inspect the unit for refrigerant leaks with a reliable leak detector if the unit is low on R-134a charge.*

CAUTION: *When adding R-134a to the unit, be careful not to OVERCHARGE the unit:*

- **Standard Receiver Tank:** *When the balls float in the middle of the sight glass, stop adding refrigerant.*
- **Water-cooled Condenser-receiver Tank:** *When the balls in the TOP sight glass float, stop adding refrigerant.*

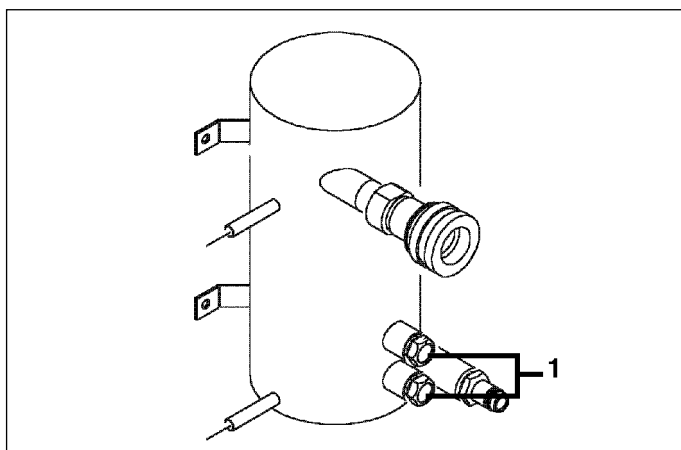

Water-Cooled Condenser-Receiver Tank (Before 8/99) (Option)

1. Two Sight Glasses: Normal refrigerant level

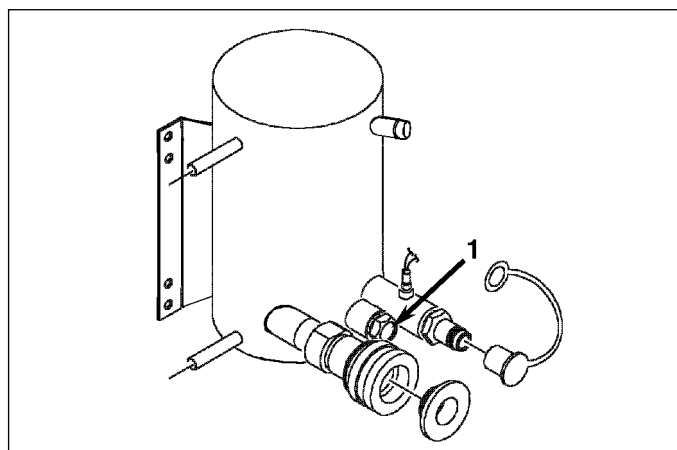

Water-Cooled Condenser-Receiver Tank (After 8/99) (Option)

1. Single Sight Glass: Refrigerant charge is OK if ball FLOATS at any time

Evacuation and Cleanup of the Refrigeration System

Contamination

Whenever contaminants have entered the system, a thorough clean up is required to prevent damage or loss of compressor.

It is well known by the refrigeration service industry that the purpose of evacuation is to remove moisture and air from the refrigeration system before charging with new refrigerant after a system has been opened. The importance of thorough evacuation and system preparation cannot be over emphasized. Even infinitesimal quantities of air or moisture in a system can cause severe problems.

We know that the presence of moisture, oxygen, and heat under certain conditions can result in many forms of damage. Corrosion, sludge, copper plating, oil breakdown, carbon formation, and eventual compressor failure can be caused by these contaminants.

Things that will contaminate a system are (in order of importance):

- **AIR** — with oxygen as a contaminant. Oxygen in the air reacts with the oil. The oil begins to break down and can eventually lead to carbonization in the compressor and acid buildup. The longer this breakdown process goes on, the darker the compressor oil becomes until finally the color is BLACK indicating major system contamination.
- **MOISTURE**. Moisture in a system will cause metal corrosion and metal plating. It can freeze in the expansion valve and cause intermittent operational problems. It reacts in the oil to begin acid buildup.
- **DIRT, DUST, METAL PARTICLES, OTHER FOREIGN MATERIALS**. Particles of any kind left to float through the system will cause severe damage to all close tolerance items. Do not leave a system open to the infiltration of dirt. If you must open a system for any reason, seal off the open areas as soon as possible and DO NOT work in a dirty environment.
- **ACID**. Air and moisture cause a chemical breakdown of the oil and/or the refrigerant itself. The acid will accelerate the deterioration of the softer metals (i.e., copper) and cause metal plating as the softer material begins to cover the inside of the system. If this condition is not stopped, it can result in the total destruction of your equipment.

Compressor Oil Color Code

BLACK OIL — indicates carbonization caused by air in the system.

BROWN OIL — indicates copper plating caused by moisture in the system.

GRAY OR METALLIC OIL — indicates bearing wear or piston scoring.

NOTE: If the compressor oil is discolored, perform a compressor oil acid test (oil test kit P/N 203-457). If the compressor oil shows an acid condition, change the oil, the in-line oil filter, the filter drier and perform a refrigeration system cleanup.

Unit Preparation and Hookup

CAUTION: Do not attempt to evacuate a unit until it is certain that the unit is leak free. A unit with less than a full charge of refrigerant should be thoroughly leak tested. Any leaks found must be repaired.

1. Recover all refrigerant from the unit and reduce the unit pressure to the proper level (US Federal Law requires a -17 to -34 kPa, -0.17 to -0.34 bar, 5 to 10 in. vacuum that is dependent upon the recovery equipment used).
2. Break vacuum with refrigerant and equalize system pressure to 0 kPa, 0 bar, 0 psig. Replace the liquid line filter drier.
3. Confirm that the Evacuation Station functions properly and determine "Blank Off" Pressure. The Blank Off Pressure of the Vacuum Pump is the deepest vacuum that the vacuum pump can attain when isolated from the rest of the system.

If a vacuum pump (isolated from a system) is started and the Micron Meter responds quickly by going to a deep vacuum, the operator can be confident that the pump and oil are in good condition. If the vacuum pump fails to reach a deep vacuum within 5 minutes, the operator should suspect the condition of the oil or the pump. It is recommended that the pump oil be changed first to see if the rate of reaching a deep vacuum is improved.
4. Connect the Evacuation Station and refrigerant tank with gauge manifold (optional) to the unit as indicated on the diagram on page 6-9. Connect evacuation hoses to the compressor suction and discharge service lines and the receiver tank outlet valve.
5. Open Evacuation Station valves (V1, V3, and V4). It is only necessary to open valve V2 when a reading on the

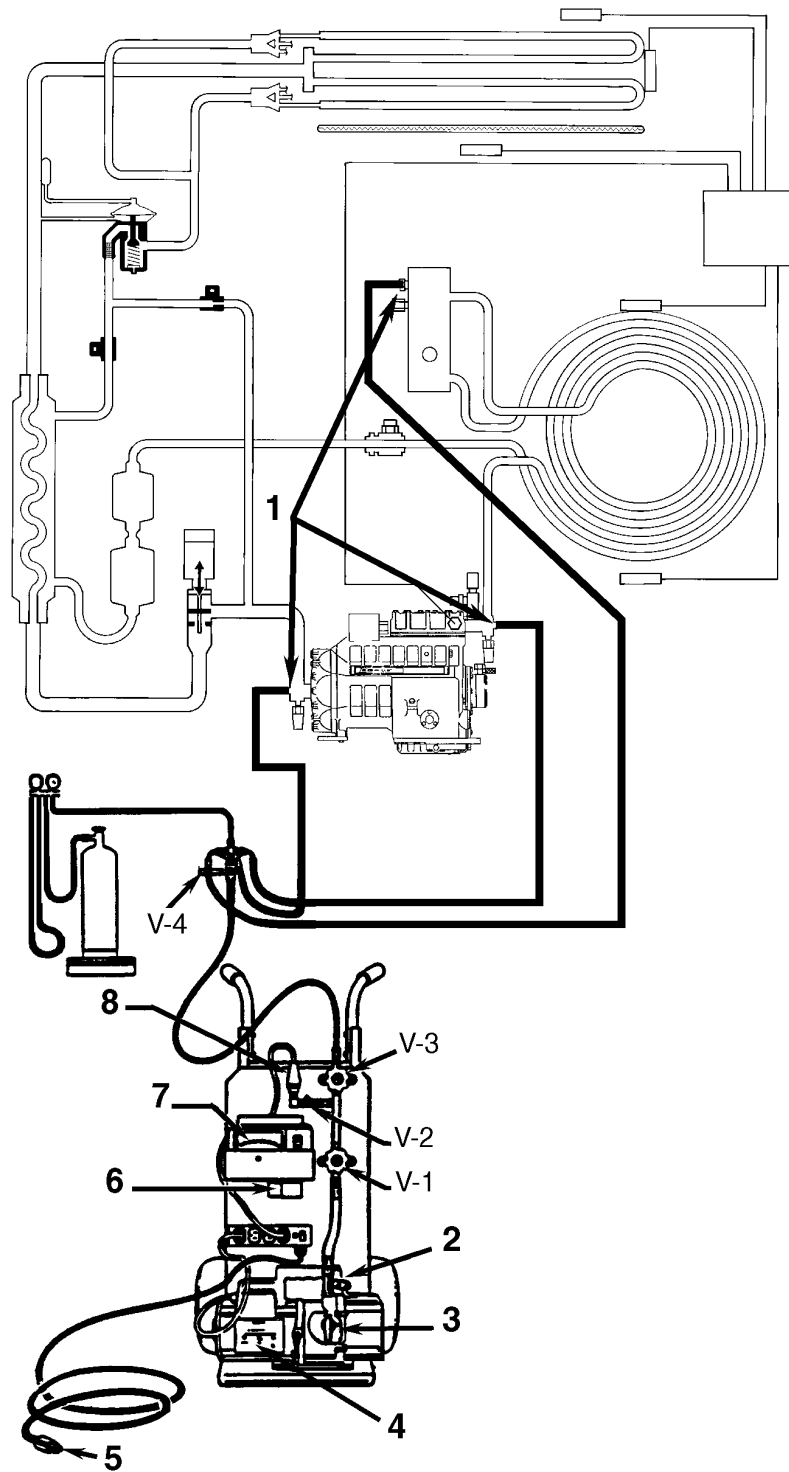

Evacuation Station and Unit Hook-up

1. Special, self-sealing quick disconnect couplers are required for R-134a units.
2. Gas Ballast Valve
3. Iso Valve
4. Two-stage Vacuum Pump
5. To 220/190 VAC Power
6. Calibration Standard
7. Micron Meter
8. Sensor

- Micron Meter is desired. This is especially true when starting to evacuate a unit and large amounts of moisture and oil will be passing by the sensor.
6. Open the vacuum pump Iso-Valve™ built into the pump housing below the handle. It is recommended that the valve be kept open at all times.
 7. If connecting a refrigerant tank and gauge manifold to the evacuation station, close the gauge manifold and refrigerant tank valves to prevent refrigerant from being drawn from the tank.

Unit Evacuation

1. Turn on the Vacuum Pump. Open the Gas Ballast Valve located on top of the pump housing behind the handle (the valve is fully open at two turns counterclockwise). Evacuate the system to 500 microns to achieve a final equilibrium pressure of 2000 microns or less. The final equilibrium pressure is determined with the Thermo King Evacuation Station using the following procedure (called a pressure-rise test):
 - a. Evacuate the system using the Evacuation Station until the vacuum level reaches 1000 microns. Then close the Gas Ballast Valve.
 - b. Continue evacuation to 500 microns or until vacuum stabilizes at its lowest level. Contamination may delay reaching the lowest level for a period of several or more hours.
 - c. Close valve V1 to isolate the vacuum pump from the system.
 - d. Observe the vacuum level on the Micron Meter.

When the Meter has stabilized, the value indicated on the Micron Meter is the equilibrium pressure. This reading must be 2000 microns or less.

NOTE: The presence of refrigerant in the compressor oil may prevent a low vacuum reading from being achieved. Compressor oil can continue to outgas for long periods of time.

2. If the vacuum level appears to stall above 500 microns, back seat the discharge service valve and observe the Micron Meter.
 - A drop in pressure indicates that the compressor oil is out-gassing and further evacuation is necessary.
 - An increase in pressure indicates that a leak exists or there is moisture in the system. Perform a “Pressure Rise Test” and evaluate.

3. Close valve V1 when the desired vacuum level has been reached.
4. Wait five minutes and read the Micron Meter.
 - A system that is leak free and dry will remain below 2000 microns for five minutes.
 - A system that rises above 2000 microns but stabilizes below atmospheric pressure is probably contaminated with moisture or has refrigerant out-gassing from the compressor oil. Additional evacuation is required.
 - A system that continues to rise without stabilizing has a leak and must be repaired.
5. If the vacuum level remained below 2000 microns for five minutes, the unit is ready to charge.

Pressure Rise Test

Evacuate the system and close valve V1. With valves V3 and V4 open, the pump is isolated and the system is held under a vacuum. If the Micron Meter rises, one of the following conditions exist.

- **Leak:** Watch the movement of the Micron Meter needle. If the needle continues to rise until it reaches atmospheric pressure, it is an indication that a leak exists somewhere in the system. When a leak is in a system, the vacuum will eventually stabilize at atmospheric pressure (see “Pressure Rise Test Evaluation” in this chapter).
- **Moisture:** When the needle indicates a rise and then stabilizes at a level below atmospheric pressure, it is an indication that the system is vacuum tight, but is still wet and requires additional dehydration and pumping time (see “Pressure Rise Test Evaluation” in this chapter).

Factors Affecting the Speed of System Evacuation

It is almost impossible to state the exact amount of time required to evacuate any system. Some factors that can influence evacuation time are listed below.

- System size
- Amount of moisture contained in the system
- Ambient temperature
- Internal restrictions within the system
- External restrictions between the system and the vacuum pump

Hose size, both diameter and length, affect evacuation times. Laboratory tests show that the evacuation time can be significantly reduced by larger diameter hoses and shorter hoses. To obtain optimum pumping speed, keep hoses as short as possible and as large in diameter as possible. For example, it takes eight times as long to pull a given vacuum through a 6

mm (1/4 inch) diameter hose as it does through a 13 mm (1/2 inch) diameter hose. It takes twice as long to pull a vacuum through a 2 meter (6 foot) long hose as it does through a 1 meter (3 foot) long hose.

Heat Saves Time

A useful and practical time saver is the application of heat to the system. Increasing the temperature of the compressor oil and refrigerant will speed up the vaporization of any water present in the system.

WARNING: Never use a torch or other concentrated heat source to heat the compressor or other refrigeration system component.

Heat lamps, electric heaters, or fans can be applied to the compressor crankcase and other parts of the system to increase the temperature of the refrigerant and compressor oil.

Unit Charging (from an Evacuated Condition)

1. Close valve V4.
2. Open the Gas Ballast valve (located on top of the pump housing behind the handle).
3. Stop the vacuum pump.
4. The discharge valve and receiver outlet valves remain mid-seated.
5. Connect the refrigerant tank with gauge manifold to the evacuation station (see "Evacuation Station and Unit Hookup" in this chapter).
6. Weigh the tank of refrigerant.
7. Check the unit data plate for the required weight of refrigerant charge then subtract the amount of the charge to be input to your unit from the total weight of the tank of refrigerant. This provides final tank weight after the unit receives a full system refrigerant charge.
8. Set the refrigerant tank for liquid removal. Open the hand valve on the tank.
9. With the unit OFF, open the gauge manifold hand valve and charge liquid refrigerant into the system.

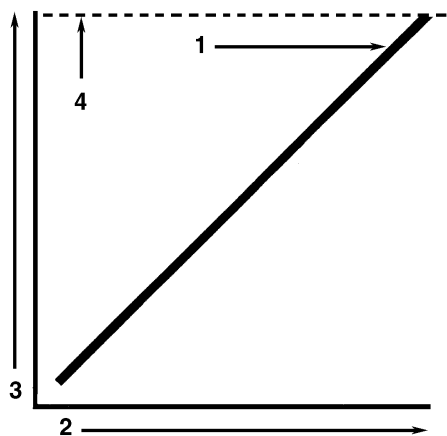

Constant Pressure Rise After Evacuation Indicates System Leak

1. Close the vacuum valve and watch the movement of vacuum gauge needle. If needle continues to rise, this is an indication that a leak exists in the unit or connecting line. The leak must then be located and eliminated.
2. Time
3. Pressure (Vacuum)
4. Atmospheric Pressure

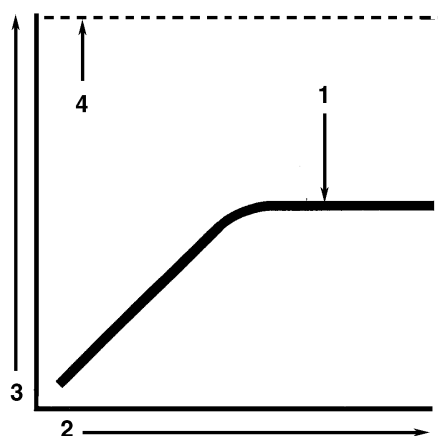

Pressure Rise Levels Off After Evacuation Indicates Moisture in System

1. Close the vacuum valve and watch the movement of vacuum gauge needle. If needle shows a pressure rise but finally levels off to a constant pressure, the system still contains too much moisture. Dehydration and additional evacuation time are required.
2. Time
3. Pressure (Vacuum)
4. Atmospheric Pressure

10. Close the refrigerant tank hand valve when the correct amount (by weight) of refrigerant has been added or if the system will take no more liquid.

The unit is now ready to have the Evacuation Station removed (described in the following steps, “Evacuation Station Removal”). See following, “Final Charging Procedure for Partially Charged Units” to complete charging procedure.

Evacuation Station Removal

1. Back seat the discharge service valve.
2. Close the refrigerant tank hand valve.
3. Operate the unit in cool mode.
4. Open the hand valve at the gauge manifold and read suction pressure.
5. Front seat the suction service valve and pump down the system to 21 to 35 kPa, 0.21 to 0.35 bar, 3 to 5 psig.
6. Back seat the suction service valve.
7. Remove the hose from the discharge service valve.
8. Install a gauge manifold set.
 - If the unit is fully charged, perform a functional check out.
 - If the unit has a partial charge, complete the charging process as described below.

Final Charging Procedure for Partially Charged Units

1. Connect the gauge manifold to the suction line and discharge line service ports. Be sure to purge the air from the lines (see “Gauge Manifold Set Attachment and Purging” in the Refrigeration Maintenance chapter of this manual).
2. Back seat and crack the discharge service valve.
3. Connect a refrigerant tank to the gauge manifold service line.
4. Set the refrigerant tank for liquid charging. Open the refrigerant tank hand valve.
5. Start and operate the unit in the COOL mode.
6. Read the suction pressure and slowly open the gauge manifold low pressure hand valve to permit suction pressure to increase approximately 170 kPa, 1.7 bar, 25 psig. This will meter liquid refrigerant slowly into the low side.

7. Add refrigerant until the receiver tank balls float at the top of the sight glass.
8. Close the hand valve on the refrigerant tank.
9. Operate the unit on COOL for 10 minutes and recheck refrigerant charge.
10. Remove the gauge manifold set.
11. Cap all service ports and valve stems.

CAUTION: *If the controller temperature setpoint was lowered to force COOL operation, be sure to return the controller to the setpoint indicated on the shipping manifest.*

Evaporator Pressure Regulator (KVQ) Valve

The evaporator pressure regulator valve is used to control the flow of refrigerant to the compressor when the unit is operating in the Modulation mode. As the supply air temperature approaches setpoint, the controller sends a voltage pulse to a heater in the valve. The heater warms a pressure reservoir in the valve actuator. As the pressure in the fluid reservoir increases, a pressure pin overcomes the spring tension in the bellows, closing the valve plate a precise amount. This throttles the suction gas returning to the compressor and reduces cooling capacity. As the frequency of the voltage pulse is increased, the pressure pin closes the valve plate an additional amount. Due to valve design, the flow of refrigerant gas exerts no opening or closing forces on the valve plate, allowing very precise operation.

NOTE: *If the electrical circuit to the heating element fails, the valve moves to the full open position.*

Service of the evaporator pressure regulator valve includes replacement of the actuator assembly or replacement of the valve body.

Tools Required:

- Digital Multimeter (P/N 204-615)
- Actuator Assembly
- Adjustable Wrench
- Torque Wrench

Heater Circuit Checkout Procedure

1. Unplug the evaporator pressure regulator valve lead wire harness.
2. Using a FLUKE multimeter, test each lead (4) resistance to ground. Low resistance indicates a short is present. Repair or replace any damaged or exposed wires.
3. Check the heater circuit and thermistor circuit resistance.
 - A good heater circuit has a resistance of 20 ohms at 25 C (78 F).
 - A good thermistor circuit has a resistance of 20,000 ohms at 25 C (78 F).

NOTE: The ohmmeter will display a slightly higher heater resistance if the valve was energized just prior to testing the circuit resistance.

4. To return the unit to service, plug the evaporator pressure regulator valve lead connector into the unit wire harness.

Valve Actuator Replacement

If the evaporator pressure regulator valve fails to operate properly, remove the actuator cover and inspect the assembly for rust or corrosion. Rust or corrosion can damage the actuator or heater circuit, preventing the valve from operating properly.

1. To replace actuator assembly, unplug the heater and thermistor lead wire harnesses.
2. Connect the unit's main power cable to the main power source and switch the refrigeration unit's On/Off switch to ON. Close the receiver tank outlet valve and pump down the low side. Equalize suction pressure to 21 kPa, 0.21 bar, 3 psig.
3. Turn the unit On/Off switch to OFF. Then disconnect the main power cable from the main power source again. Close (front seat) the discharge service valve.

CAUTION: Any time the discharge valve is front seated, disconnect the unit power source to prevent accidental compressor start-up.

4. Inspect the actuator terminals and note the wire connection sequence. Then disconnect wire leads.
5. Unscrew the actuator assembly from the valve body.
6. Immediately insert new actuator assembly in valve body.
7. Thread new actuator into valve body until it is hand tight. Then tighten to 45 N.m (33 ft-lb).
8. Connect wire leads to actuator terminals in proper sequence.
9. Replace cover on actuator assembly.

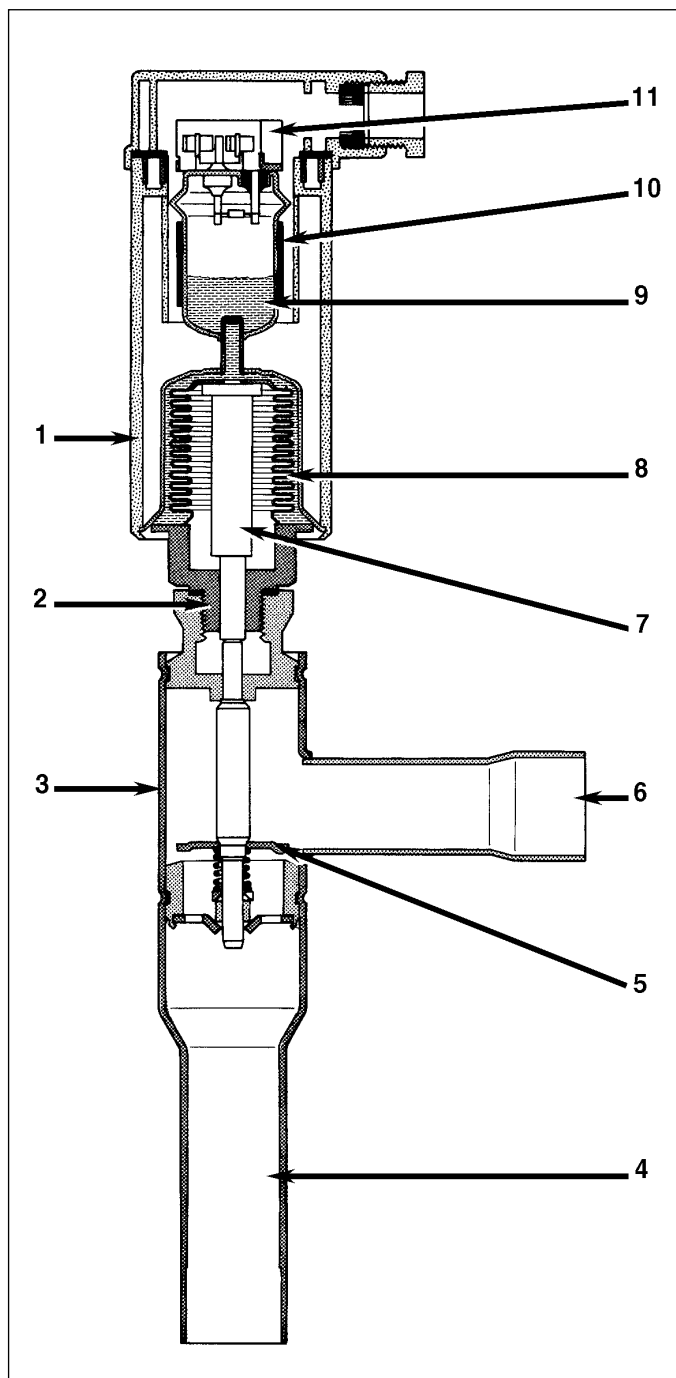

KVQ Valve

1. Actuator Assembly
2. Threaded Connection
3. Valve Body
4. Inlet Tube
5. Valve Plate
6. Outlet Tube
7. Pressure Pin
8. Bellows Assembly
9. Pressure Reservoir
10. Heating Element
11. Terminal Connections

10. Connect the heater and thermistor lead wire harnesses.
11. Evacuate the low side.
12. Open the discharge valve. Then open the receiver tank outlet valve.
13. Verify that all personnel are clear and connect main power plug to power supply. Place the unit back in service.

KVQ Valve Replacement

If the valve body is damaged, replace the entire valve.

1. Connect the unit's main power cable to the main power source and switch the refrigeration unit's On/Off switch to ON.
2. Close receiver tank outlet valve and pump down the low side to 21 kPa, 0.21 bar, 3 psig.
3. Turn the unit On/Off switch to OFF. Then disconnect the main power cable from the main power source. Close (front seat) the discharge service valve.

CAUTION: Any time the discharge valve is front seated, disconnect the unit power source to prevent accidental compressor start-up.

4. Unplug the heater and thermistor lead wire harnesses.
5. Unsolder the valve outlet (compressor side) joint from the suction line. Unsolder the inlet joint and remove valve.
6. Clean the tubes for soldering. Position the new valve in position in the suction line.
7. Solder both modulation valve connections.

CAUTION: Use a heat sink or wrap the valve with wet rags to prevent damage to the new valve.

8. Pressurize the low side and test for refrigerant leaks (see "Refrigerant Leak Test Procedure" in the Refrigeration Maintenance chapter of this manual).

NOTE: If pressurizing with nitrogen, front seat the discharge valve to prevent nitrogen from entering the refrigerant charge.

9. If no leaks are found, evacuate the low side and recover the leak test gas (see "Refrigerant Recovery" in the Refrigeration Maintenance chapter of this manual).
10. Plug the heater and thermistor wire harnesses into the unit wire harness.
11. Open the discharge valve. Then open the receiver tank outlet valve.
12. Verify that all personnel are clear and connect main power plug to power supply. Start the unit and check the refrigerant charge. Add refrigerant as required.

Refrigerant Recovery

Caution: Use only refrigerant recovery equipment approved for and dedicated to R-134a recovery.

When removing any refrigerant from a Thermo King refrigeration system, use a recovery process that prevents or absolutely minimizes the refrigerant that can escape to the atmosphere. Typical service procedures that require removal of refrigerant from the unit include:

- To reduce the refrigerant pressure to a safe working level when maintenance must be performed on high-pressure side components.
- To empty the unit of refrigerant when an unknown amount of charge is in the system and a proper charge is required.
- To empty the unit of contaminated refrigerant when the system has become contaminated.

NOTE: Always refer to specific recovery equipment Operator and Service Manuals.

Vapor Recovery

1. Install a gauge manifold set on the unit. Attach the service line to the recovery machine and properly purge the lines. Set the recovery machine for vapor recovery.
2. Keep unit OFF and mid-seat the discharge service valve.
3. Turn ON the recovery machine and open (back seat) both gauge manifold and hand valves.
4. Continue to operate the recovery machine until unit pressures drop to 0 kPa, 0 bar, 0 psig pressure.

Liquid Recovery

1. Install a gauge manifold's low-pressure line to the Schrader suction service valve in the suction line (near modulation valve). Attach the manifold's high-pressure line to receiver tank outlet valve service port. Attach the service line to the recovery machine and purge the lines.
2. Operate the unit and build discharge pressures to approximately 1380 kPa, 13.80 bar, 200 psig.
3. Close the receiver tank outlet valve and pump down the low-pressure side of the system.
4. Stop the unit.
5. Set recovery machine for liquid recovery and turn it ON.
6. Open (back seat) high-pressure valve on gauge manifold.
7. Operate the recovery machine until the unit system pressures reach approximately 0 kPa, 0 bar, 0 psig.

Using Pressurized Nitrogen

The improper use of high pressure cylinders can cause physical damage to components, or personal injury, or cause stress that would lead to failure of components.

Safety Precautions

Observe the proper handling of cylinders:

1. Always keep protective cap on cylinder when not in use.
2. Secure cylinder in proper storage area or fastened to cart.
3. DO NOT expose to excessive heat or direct sun light.
4. DO NOT drop, dent, or damage cylinder.
5. Use a pressure regulator and a safety pressure relief valve as part of the pressure testing equipment. The safety pressure relief valve should be of the non-adjustable, non-tempering type. The valve should bypass any time the pressure exceeds its setting.
6. Open valve slowly; use regulators and safety valves that are in good working order.
7. The regulator should have two gauges; one to read tank pressure, the other to read line pressure. Properly maintained equipment will allow leak testing, purging, or dehydration to be done safely.

CAUTION: Nitrogen (N_2) is under 15,170 kPa, 151.70 bar, 2200 psig, or greater. Pressure is for full cylinder at 21 C (70 F). DO NOT use Oxygen (O_2), acetylene or any other types of pressurized gas on refrigeration systems or any component of a system.

Dehydration, pressure testing, purging and soldering can be accomplished with the use of dry nitrogen (N_2). The proper equipment and application of equipment is of greatest importance.

Procedure

1. Attach gauge manifold set (refer to "Gauge Manifold Set Attachment and Purging" for proper procedure for connecting to compressor).
2. Close both hand valves on the gauge manifold (front seated).
3. Connect charging hose to a source of nitrogen. Adjust pressure regulator to the proper pressure for the required procedure.

4. Purge system high side to low side.

The following procedures should utilize the following MAXIMUM gas pressure:

- Leak Testing: 1030 to 1200 kPa, 10.3 to 12.0 bar, 150-175 psig,
- Purging/Dehydration: 70 to 140 kPa, 0.7 to 1.4 bar, 10-20 psig,
- Soldering: 35 kPa, 0.35 bar, 5 psig.

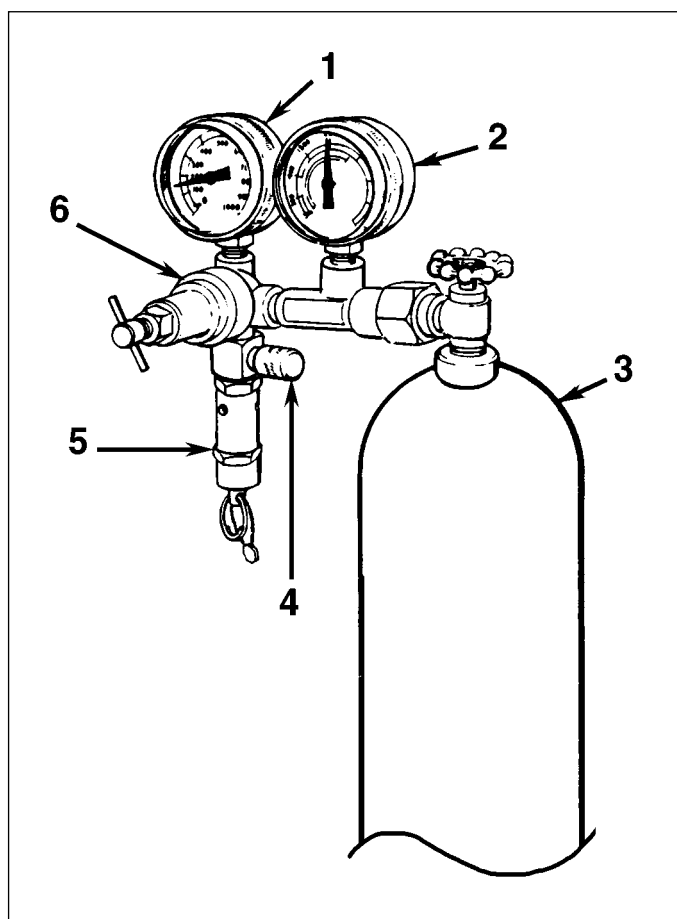

Typical Pressurized Gas Bottle with Pressure Regulator and Gauges

1. Line Pressure
2. Tank Pressure
3. Tank
4. Pressure Test Line to System
5. Safety Valve
6. Pressure Regulator

Compressor Replacement

Removal

1. Remove the compressor compartment bracket. Close the liquid line service valve and pump down the low side to -35 kPa, -0.35 bar, 10 in. vacuum. Break the vacuum with nitrogen between 10 and 20 kPa, 0.10 and 0.20 bar, 1 and 3 psig.

NOTE: If the compressor does not operate, or the compressor is unable to pump the low side down, the refrigerant charge must be reclaimed before service can be performed on the refrigeration system.

2. Front seat the discharge valve.

CAUTION: Any time the discharge valve is front seated, disconnect the unit power source to prevent accidental compressor start-up.

3. Remove discharge service valve, suction service valve, and liquid injection line from the compressor.
4. Disconnect the wire connector for the high pressure cutout switch, condenser pressure switch, and compressor discharge temperature sensor.
5. Remove the three-phase electric power connection.
6. Remove the compressor mounting tray bolts and nuts.
7. Slide the compressor from the unit.
8. Keep the compressor ports covered to prevent dust, dirt, etc., from falling into the compressor.

NOTE: When the compressor is removed from the unit, oil level should be noted or the oil removed from the compressor should be measured so that the same amount of oil can be added before placing the new compressor or repaired compressor in the unit.

Installation

1. Slide the compressor into the unit. Install mounting bolts, washers and nuts, and tighten.
2. Bolt the discharge valve to the compressor with a new gasket lightly coated with compressor oil. Bolt the suction service valve to the compressor using a new O-ring coated with compressor oil.
3. Apply refrigerant locktite to the threads of the switches. Install the switches. Connect the wire connectors for the condenser fan pressure switch, high pressure cutout switch, and compressor discharge temperature sensor.
4. Connect liquid injection line to compressor body.
5. Connect three-phase electric power to the compressor.
6. Pressurize the compressor with refrigerant gas (same gas as that used in the system). Check for refrigerant leaks around the compressor assembly and gasket connections.
7. If no leaks are found, recover the refrigerant used for the leak test (see "Refrigerant Recovery" in this chapter). Because this refrigerant gas will contain some air, place it in a contaminated refrigerant bottle to be reclaimed later.
8. After all pressure is removed from the low side and compressor, hook up your evacuation equipment.
9. Evacuate the low side and compressor (see "Evacuation and Cleanup of the Refrigeration System" in this chapter).
10. Back seat the discharge service valve and open the liquid line service valve fully.
11. Operate the unit at least thirty minutes and then inspect the oil level in the compressor. Add or remove oil if necessary.
12. Check the refrigerant charge and add refrigerant if needed.

Condenser Coil Replacement

Removal

1. Recover the refrigerant charge from the unit (do NOT vent refrigerant to the atmosphere).
2. Remove the condenser fan grille, condenser fan blade and condenser fan shroud.
3. Remove the condenser coil support brackets from the coil.
4. Unsolder the coil inlet and liquid line connections.
5. Support the coil and unbolt the condenser coil mounting brackets. Slide the coil from the unit.

Installation

1. Clean the tubes for soldering.
2. Slide the coil into the unit and install the bolts in the mounting brackets.
3. Solder the inlet line and liquid line connections.

NOTE: It is strongly recommended that dry nitrogen be used to purge the system during any solder operations (see “Using Pressurized Nitrogen” in this chapter).

4. Pressurize the system and test for leaks (see “Refrigerant Leak Test Procedure” in this chapter).
5. If no leaks are found, recover the leak test gas (see “Refrigerant Recovery” in this chapter).
6. Then evacuate the system (see “Evacuation and Cleanup of the Refrigeration System” in this chapter).
7. Replace the condenser coil support brackets, condenser fan shroud and condenser fan grille.
8. Recharge the unit with R-134a refrigerant and check the compressor oil level. Add oil if necessary.

Dehydrator (Filter Drier) or In-line Filter Replacement

Removal

1. Close the liquid line service valve and pump down the low side. Open the outlet valve slightly to equalize the pressure to 21 kPa, 0.21 bar, 3 psig.
2. Place the new dehydrator (or in-line filter) near the unit for immediate installation.

3. Using two wrenches, “crack” both dehydrator (or in-line filter) line mountings. Use two wrenches on flare fittings to prevent line damage.
4. Separate the dehydrator (or in-line filter) line mountings.
5. Remove the filter bracket clamping nuts and bolts.

NOTE: Perform the following four procedures as quickly as possible to prevent contamination.

6. Remove the old dehydrator (or in-line filter) from the line.

Installation

1. Remove the sealing caps from the new dehydrator (or in-line filter).
2. Apply clean compressor oil to dehydrator (or in-line filter) threads.
3. Assemble new dehydrator (or in-line filter) to lines. Finger tighten mounting nuts.

NOTE: To prevent incorrect installation of the dehydrator (or in-line filter), the inlet and outlet fittings are different sizes.

4. Reinstall clamping brackets, nut and bolts. Tighten the bolts.
5. Tighten the dehydrator (or in-line filter) inlet line mounting nut.
6. Open the liquid line service valve on the inlet side of the dehydrator (or in-line filter) slowly to release a small amount of refrigerant from the receiver tank to purge the air through the filter. Then tighten the outlet nut.

NOTE: When removing or replacing the o-ring nuts on the dehydrator (or in-line filter), always hold the body of the dehydrator (or in-line filter) near the flange fittings to prevent twisting the tubing when the nuts are being loosened or tightened.

7. Back seat (open) the liquid line service valve.
8. Test the dehydrator (or in-line filter) for leaks (see “Refrigerant Leak Test Procedure” in this chapter).
9. If no leaks are found, place the unit in operation.

Expansion Valve Replacement

Removal

1. Close the liquid line service valve and pump down the low side to -35 kPa, -0.35 bar, 10 in. vacuum. Break the vacuum with nitrogen between 10 and 20 kPa, 0.10 and 0.20 bar, 1 and 3 psig.
2. Remove insulating tape and unclamp feeler bulb from the suction line in the condenser section. Note the position of the feeler bulb on the side of the suction line.
3. Remove insulating tape from expansion valve outlet line.
4. Heat and unsolder the equalizer line from expansion valve.
5. Heat and unsolder the liquid line inlet and outlet connections to expansion valve in condenser section.
6. Remove expansion valve from unit.

Installation

1. Clean the liquid lines and equalizer lines for soldering.
2. Place new expansion valve in position in liquid line.
3. Solder liquid line inlet and outlet line connections to valve.
4. Solder equalizer line to expansion valve.
5. Clean the suction line to a bright polished condition. Install the feeler bulb of new power head in the feeler bulb clamp on the suction line. Locate bulb on the suction line in former position. The feeler bulb must make good contact with the suction line or operation will be faulty. Cover with insulating tape.
6. Pressurize the low side and test for leaks (see "Refrigerant Leak Test Procedure" in this chapter).
7. If no leaks are found, recover the leak test gas (see "Refrigerant Recovery" in this chapter).
8. Evacuate the low side (see "Evacuation and Cleanup of the Refrigeration System" in this chapter).
9. Cover expansion valve outlet line with insulating tape.
10. Open the liquid line service valve and place the unit in operation.
11. Operate the unit and note the suction pressure and container temperature to see that the expansion valve is properly installed and that the feeler bulb is properly located.

Heat Exchanger Replacement

Removal

1. Close the liquid line service valve and pump down the low side to -35 kPa, -0.35 bar, 10 in. vacuum. Break the vacuum with nitrogen between 10 and 20 kPa, 0.10 and 0.20 bar, 1 and 3 psig.
2. Remove the "U" mounting clamps that hold the heat exchanger assembly to the wall of the condenser section.
3. Heat and unsolder liquid inlet and outlet line connections.
4. Note position of feeler bulb on the side of the suction line. Un-tape and remove the feeler bulb from the suction line.
5. Heat and unsolder the suction line connections.
6. Lift the heat exchanger assembly from the unit.

Installation

1. Clean the tubes for soldering.
2. Place the heat exchanger assembly in the unit and install the mounting hardware.
3. Solder the suction line connections.

NOTE: It is strongly recommended that dry nitrogen be used to purge the system during any solder operations (see "Using Pressurized Nitrogen" in this chapter).

NOTE: If pressurizing with nitrogen, front seat the discharge valve to prevent nitrogen from entering the refrigerant charge.

CAUTION: Any time the discharge valve is front seated, disconnect the unit power source to prevent accidental compressor start-up.

4. Solder the liquid line connections.
5. Pressurize the low side and check for leaks (see "Refrigerant Leak Test Procedure" in this chapter).
6. If no leaks are found, recover the leak test gas (see "Refrigerant Recovery" in this chapter).
7. Evacuate the low side (see "Evacuation and Cleanup of the Refrigeration System" in this chapter).
8. Clean suction line to a bright polished condition. Install feeler bulb in the feeler bulb clamps on the suction line. Locate bulb on the suction line in former position. The feeler bulb must make good contact with the suction line or operation will be faulty. Cover with insulating tape.
9. Open the liquid line service valve and place unit in opera-

tion. Operate unit and note suction pressure and container temperature to see that feeler bulb is properly installed.

Receiver Tank Replacement

Removal

1. Recover the refrigerant charge from the unit (see “Refrigerant Recovery” in this chapter).
2. Unsolder the outlet valve on the liquid outlet line.
3. Unsolder the liquid line inlet connection.
4. Loosen the mounting nuts and remove the tank.
5. Remove the adapter with fusible plug (or relief valve), service fitting, water fittings (option) and water pressure switch (option) from the receiver tank for installation in new tank.

Installation

1. Install a new tank in the unit and tighten the mounting bolts.
2. Solder the inlet line and outlet valve line with high temperature silver solder (30% silver).

NOTE: *It is strongly recommended that dry nitrogen be used to purge the system during any solder operations (see “Using Pressurized Nitrogen” in this chapter).*

NOTE: *If pressurizing with nitrogen, front seat the discharge valve to prevent nitrogen from entering the refrigerant charge.*

CAUTION: *Any time the discharge valve is front seated, disconnect the unit power source to prevent accidental compressor start-up.*

3. Pressurize the refrigeration system and check for leaks (see “Refrigerant Leak Test Procedure” in this chapter).
4. Evacuate the system (see “Evacuation and Cleanup of the Refrigeration System” in this chapter).
5. Recharge the unit (see “Refrigerant Charge” in this chapter).

High Pressure Cutout Switch, Condenser Fan Speed Pressure Switch, or Compressor Discharge Gas Temperature Sensor Replacement

Removal

1. Close the liquid line service valve and pump down the low side. Open the outlet valve slightly to equalize the pressure between 10 and 20 kPa, 0.10 and 0.20 bar, 1 and 3 psig.
2. Front seat the discharge service valve.

CAUTION: *Any time the discharge valve is front seated, disconnect the unit power source to prevent accidental compressor start-up.*

3. Purge the high pressure from the compressor head through the service port on the discharge line.
4. Disconnect the leads from the wire harness and remove the switch from the compressor discharge manifold (or remove the sensor from the compressor head).

Installation

1. Apply a refrigeration locktite (sealant) to the threads of the switch (or sensor).
2. Install and tighten the switch (or sensor). Connect the leads to the wire harness.
3. Open discharge service valve slightly to pressurize the compressor head and tube assembly. Check for leaks (see “Refrigerant Leak Test Procedure” in this chapter). Front seat the discharge service valve.
4. If no leaks are found, recover the leak test gas (see “Refrigerant Recovery” in this chapter).
5. Open the liquid line service valve and compressor discharge service valve and place the unit in operation.

Liquid Line Solenoid Valve Replacement

Removal

1. Close the liquid line service valve and pump down the low side to -35 kPa, -0.35 bar, 10 in. vacuum. Break the vacuum with nitrogen between 10 and 20 kPa, 0.10 and 0.20 bar, 1 and 3 psig.
2. Turn the unit On-Off switch OFF. Disconnect electrical connections to liquid line solenoid.

NOTE: In most cases, only the coil requires replacement. No other repair is possible on the liquid line solenoid.

3. Unsolder the liquid line connections from the valve.
4. Remove the valve from the unit.

Installation

1. Clean the tubes for soldering.
2. Place the new valve in position and solder the connections.

CAUTION: Use a heat sink or wrap the valve with wet rags to prevent damage to the new valve.

3. Release a small amount of refrigerant from the receiver tank to pressurize the liquid line. Check for leaks (see “Refrigerant Leak Test Procedure” in the Refrigeration Maintenance chapter of this manual).
4. If no leaks are found, recover the leak test gas (see “Refrigerant Recovery” in the Refrigeration Maintenance chapter of this manual).
5. Evacuate the low side (see “Evacuation and Cleanup of the Refrigeration System” in the Refrigeration Maintenance chapter of this manual).
6. Reconnect the electrical wires to the valve.
7. Open the liquid line service valve and place the unit in operation. Check the refrigerant charge and add refrigerant as required.

Liquid Injection Valve Replacement

Removal

1. Close the liquid line service valve and pump down the low side to -35 kPa, -0.35 bar, 10 in. vacuum. Break the vacuum with nitrogen between 10 and 20 kPa, 0.10 and 0.20 bar, 1 and 3 psig.
2. Disconnect the unit power source from the unit. Disconnect the electrical connections to the liquid injection valve.

NOTE: In most cases, only the coil requires replacement. No other repair is possible on the liquid injection valve.

3. Unsolder the liquid line connections.
4. Unbolt and remove the valve from the unit.

Installation

1. Clean the tubes for soldering.
2. Place the new valve in position.
3. Solder the liquid line connections.

CAUTION: Use a heat sink or wrap the valve with wet rags to prevent damage to the new valve.

4. Pressurize the low side with refrigerant and check for leaks (see “Refrigerant Leak Test Procedure” in this chapter).
5. If no leaks are found, recover the leak test gas (see “Refrigerant Recovery” in this chapter).
6. Evacuate the low side (see “Evacuation and Cleanup of the Refrigeration System” in this chapter).
7. Reconnect the electrical wires to the valve.
8. Open the liquid line service valve and place the unit in operation. Check the refrigerant charge and add refrigerant as required.

Dehumidify Valve (Option) Replacement

Removal

1. Close the liquid line service valve and pump down the low side to -35 kPa, -0.35 bar, 10 in. vacuum. Break the vacuum with nitrogen between 10 and 20 kPa, 0.10 and 0.20 bar, 1 and 3 psig.
2. Remove insulating tape from liquid line.
3. Disconnect the electrical connections to the dehumidify valve.

NOTE: *In most cases, only the coil requires replacement. No other repair is possible on the liquid injection valve.*

3. Unsolder the liquid line connections.
4. Unbolt and remove the valve from the unit.

Installation

1. Clean the tubes for soldering.
2. Place the new valve in position.
3. Solder the liquid line connections.

CAUTION: *Use a heat sink or wrap the valve with wet rags to prevent damage to the new valve.*

4. Pressurize the low side with refrigerant and check for leaks (see “Refrigerant Leak Test Procedure” in this chapter).
5. If no leaks are found, recover the leak test gas (see “Refrigerant Recovery” in this chapter).
6. Evacuate the low side (see “Evacuation and Cleanup of the Refrigeration System” in this chapter).
7. Cover liquid lines with insulating tape.
8. Reconnect the electrical wires to the valve.
9. Open the liquid line service valve and place the unit in operation. Check the refrigerant charge and add refrigerant as required.

7

Structural/Accessory Maintenance

Mounting Bolts

Check and tighten all unit, compressor, and fan motor mounting bolts during pretrip inspections and every 1,000 operating hours. Unit mounting bolts should be tightened to a torque value of 204 N.m (150 ft-lb). Compressor and fan motor mounting bolts should be tightened to a torque value of 20 to 21 N.m (15 to 20 ft-lb).

Unit Inspection

Inspect the unit during unit pretrip inspection and every 1,000 operating hours for loose or broken wires or hardware, compressor oil leaks, or other physical damage which can affect unit performance and require repair or replacement of parts.

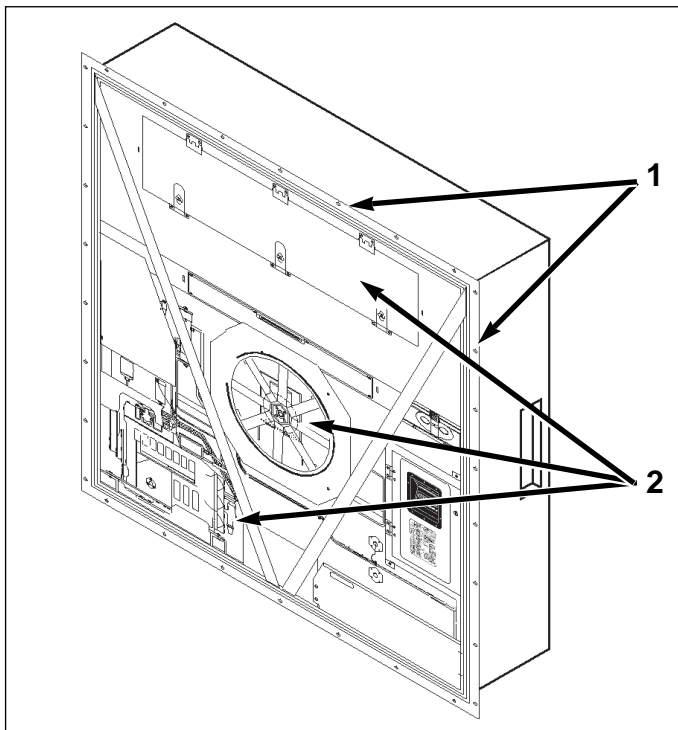

Mounting Bolts

1. Tighten Unit Mounting Bolts
2. Tighten Compressor, Condenser Fan and Evaporator Fan Mounting Bolts

Condenser Coil

Clean the condenser coil by blowing low pressure compressed air or a medium pressure warm water spray from the inside of the coil outward (opposite direction of normal airflow). Inspect coil and fins for damage and repair if necessary.

CAUTION: Air pressure or water spray must not be high enough to damage coil fins.

If a build up of salt or debris is present on the condenser coil, the coil should be cleaned using a mild alkaline cleaner with a pH of 9.5 to 10.5. For example, a 2-3% solution of SIMPLE GREEN® would make a suitable cleaning solution. Apply the solution using a pressure spray/wash type apparatus. Spray the condenser coil thoroughly from both the inside and outside of the coil. Always thoroughly rinse the coil with a fresh water spray.

Also inspect the directional airflow condenser grille for damage. This grille directs the condenser airflow out and away from the unit to increase the efficiency of the condenser coil by preventing the recirculation (short cycling) of warm air through the coil. Abnormally high head pressures may result if this special condenser grille is damaged or missing.

Evaporator Coil

Clean the evaporator coil by blowing low pressure compressed air from the bottom side of the coil upward (opposite direction of normal airflow). Inspect coil and fins for damage and repair if necessary.

CAUTION: Air pressure must not be high enough to damage coil fins.

Defrost Drains

Clean the defrost drains every 1,000 operating hours to be sure the lines remain open.

Evaporator Fan Location

Place fan blade on motor shaft with hub located on the outside of the blade for proper airflow direction. When mounting the fan blade and hub assembly on the fanshaft, center the assembly in the orifice. Position the front (top) of the fan blade hub 13 mm (0.5 in.) in from the outer edge of the fan orifice.

Condenser Fan Location

Place fan blade on motor shaft with hub located on the outside of the blade for proper airflow direction. When mounting the fan blade and hub assembly on the fanshaft, center the assembly in the orifice. Position the front of the fan blade 10 mm (0.4 in.) in from the outer edge of the fan orifice.

Fresh Air Exchange System

The fresh air exchange system has an adjustable vent door that is precalibrated for air exchange rates between 0 and 160 m³/hr (0 and 94 ft³/min.) on CRR-20 units; 0 and 285 m³/hr (0 and 168 ft³/min.) on CRR-40 units. The evaporator fans draw in outside air through an air intake and discharge an equal amount of container air through an air outlet.

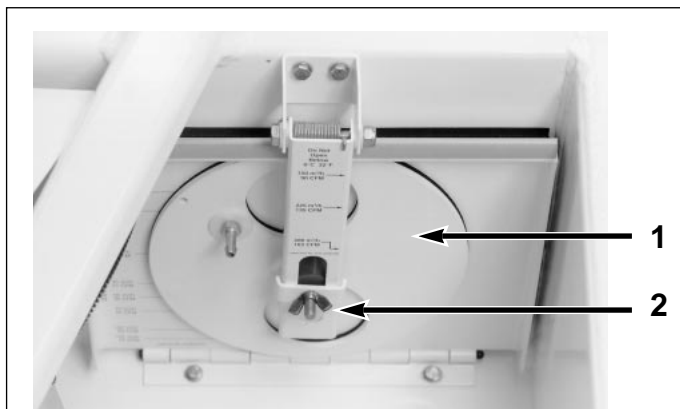

Air Exchange System

1. Air Vent Adjustment Disk
2. Adjustment Wing Nut

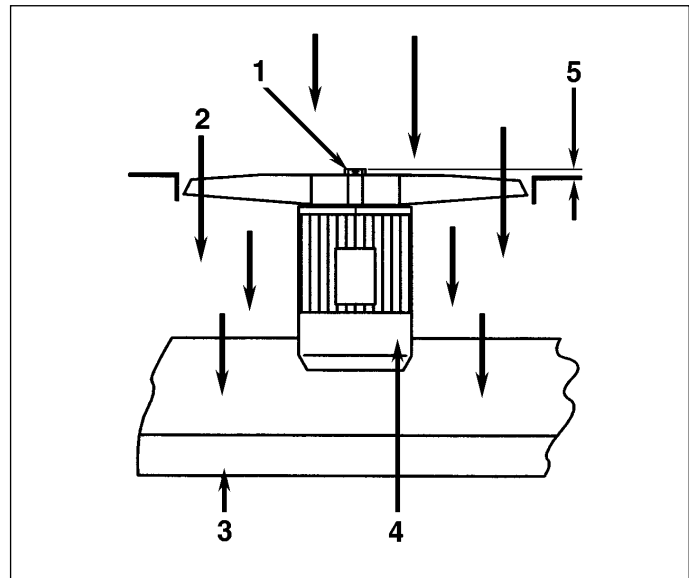

Evaporator Fan Blade Placement

1. Evaporator Fan Blade
2. Airflow Direction
3. Evaporator Coil
4. Evaporator Motor
5. 13 mm (0.5 in.)

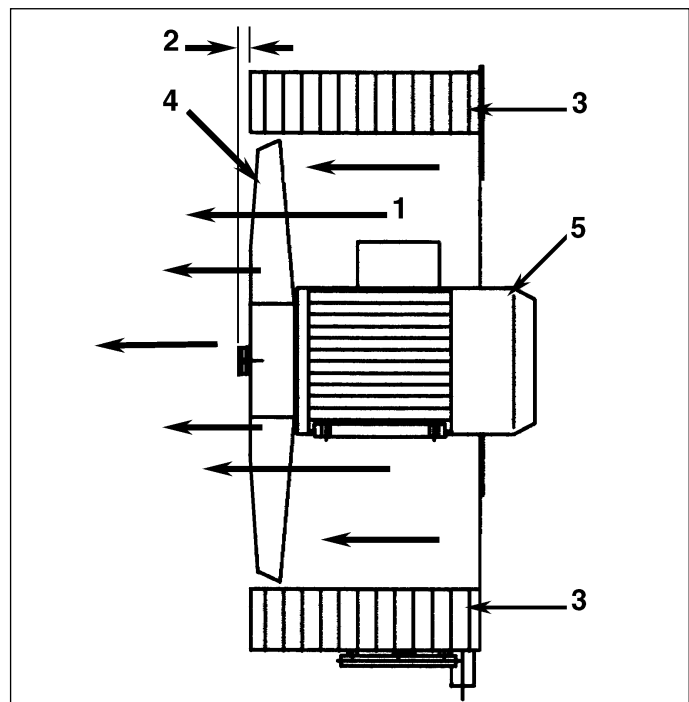

Condenser Fan Blade Placement

1. Airflow Direction
2. 10 mm (0.4 in.)
3. Condenser Coil
4. Condenser Fan Blade
5. Condenser Motor

Partlow (Model SR) Recording Thermometer (Option)

The 31-day Partlow Recorder is mechanically driven by a spring wound mechanism. The sensor bulb is mounted in the evaporator to record the return air temperature.

The recording thermometer should be inspected and cleaned to ensure that the stylus produces smooth clean lines and records accurate temperature readings. When changing charts, wipe the stylus and chart platen with a clean, damp

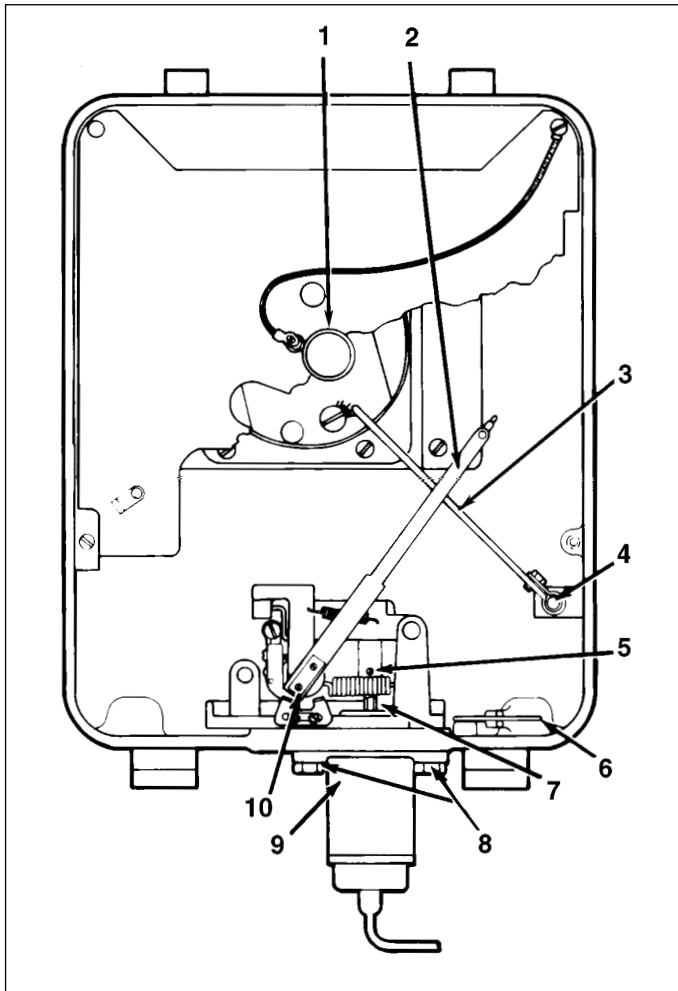

Partlow (SR) Recording Thermometer

1. Knurled Knob
2. Recording Stylus
3. Lifter Arm
4. Allen Screw
5. Set Screw "S"
6. Key Mounting Clip
7. Adjustment Shaft "J"
8. Element Flange Screws "D"
9. Thermal Element
10. Stamping

cloth to remove material transferred from the back of the chart to the platen by the pressure of the stylus.

Recording Chart Replacement

1. To change the charts, remove the knurled chart nut from the drive shaft and remove the chart.
2. Install the new chart on the chart drive shaft. Position the chart edge under the four clips.
3. Replace the chart nut loosely and rotate the chart so that the correct time is indicated by the stylus. In order to operate the stylus with the door open for the purpose of checking or zeroing the control, the lifter arm can be locked in this lowered position by pushing down on the lifter arm shaft and rotating the arm on its pivot point. If the lifter arm does not retract away from the stylus when the door is closed, reposition the arm on the shaft by loosening the Allen screw on the lifter arm.
4. Hold the recording chart in position and tighten the chart nut finger tight.
5. Lower the pen by rotating the lifting arm counterclockwise and pushing the pen against the chart. If there is insufficient pressure on the stylus to mark the chart, carefully grip the pivot end of the stylus where it is riveted to the stamping with a pair of long-nosed pliers. Bend the stamping toward the instrument. Care must be used not to bend the stylus arm, but only the stamping to which it is attached.

Recording Stylus Calibration

1. Visually inspect the recording thermometer sensing bulb located in the evaporator near the return air grille. Make sure it is securely fastened and clear of debris.
2. Start the unit and adjust the temperature setpoint to 0 C (32 F). Operate the unit until the return air temperature reaches 0 C (32 F). Enter the View menu on the controller display and scroll to the return air temperature ("RET") screen. Press the ENTER key to lock the "RET" screen on the display.
5. Wait at least 5 minutes to allow the recording thermometer sensing bulb temperature to stabilize. Then compare the "RET" temperature in the controller display with the recording stylus of the recorder. Write down both readings.
6. If the average difference is 0.6 C (1.0 F) or less, DO NOT attempt to recalibrate.

7. If the recorder needs recalibration:
 - a. Loosen the Allen setscrew (S) using a small slotted screwdriver.
 - b. Adjust shaft (J) with a 5 mm (3/16 in.) open end wrench until the recording stylus pointer is aligned to the temperature reading that agrees with the "RET" controller display. To decrease the stylus temperature reading, turn the shaft to the left (clockwise). To increase the reading, turn the shaft to the right (counterclockwise).
 - c. Tighten Allen setscrew (S).
 - d. Wait another 5 minutes while the unit operates on Cool. Verify that the recording thermometer reading is stable and agrees with the "RET" temperature in the controller display.
 - e. Press any key to unlock the controller display screen.

Element Replacement

The recording thermometer's thermal element is field replaceable. To replace the element:

1. Remove element flange screws (D) and withdraw the thermal element from the recorder case. Care must be taken not to bend the hex shaft which extends from the recorder case.
2. Remove the old sensing bulb and capillary from the unit.
3. Install the new sensing bulb and capillary in the unit. The capillary of the new thermal element may be bent, but DO NOT bend the bulb.
4. Install a new thermal element in the recorder case.
3. Replace the element flange screws (D) and tighten securely.
4. Check the calibration of the recorder. Recalibrate the recorder if necessary.

Saginomiya (Model SKM) Recording Thermometer (Option)

The 31-day Saginomiya Recorder is electric motor driven by a dry cell type battery with a 1 year life expectancy. The sensor bulb is mounted in the evaporator to record the return air temperature.

The recording thermometer should be inspected and cleaned to ensure that the stylus produces smooth clean lines and records accurate temperature readings.

Battery

The recording chart is driven by a battery-powered quartz motor and reducing gear. The battery charge should be checked during unit pretrip inspection or once a month. To check the battery charge, press the button the voltage indicator:

- Blue Zone — Battery good. If the indicator needle remains in the blue zone when the test button is depressed, the battery has sufficient power to operate the recorder.
- White Zone — Replace battery within 30 days. If the indicator needle remains in the white zone when the test button is depressed during a pretrip inspection, replace the battery. Although the battery may operate the recorder up to 30 more days, replacing the battery before it is completely dead is recommended.
- Red Zone — Dead battery. If the indicator needle remains in the red zone when the test button is depressed, the battery is dead and must be replaced.

To replace the battery:

1. Raise the stylus away from the chart by rotating the pen lift gear clockwise 30 degrees and releasing the lifting arm. The pen will remain in the raised position. Remove the knurled chart nut from the drive shaft and remove the chart.
2. Loosen the four setscrews that hold the recording platen in the recorder. The setscrews do not remove from the recorder base.
3. Rotate the recording platen counterclockwise and remove the platen.
4. Remove the battery from the recorder.
5. Install a new battery in the recorder making sure the battery's positive (+) and negative (-) poles are correctly aligned.
6. Press the button on the voltage indicator to make sure the indicator needle is in the blue zone.

7. Check to see that the quartz motor is running. Look through the inspection window and make sure the internal flywheel on the quartz motor is revolving.
8. Replace the recording platen on the recorder base and rotate clockwise to view setscrews. Tighten four setscrews that hold the platen in the recorder
9. Replace the recording chart and chart nut on the chart drive shaft and tighten the chart nut finger tight.
10. Lower the pen by rotating the lifting arm counterclockwise and push the pen against the chart.

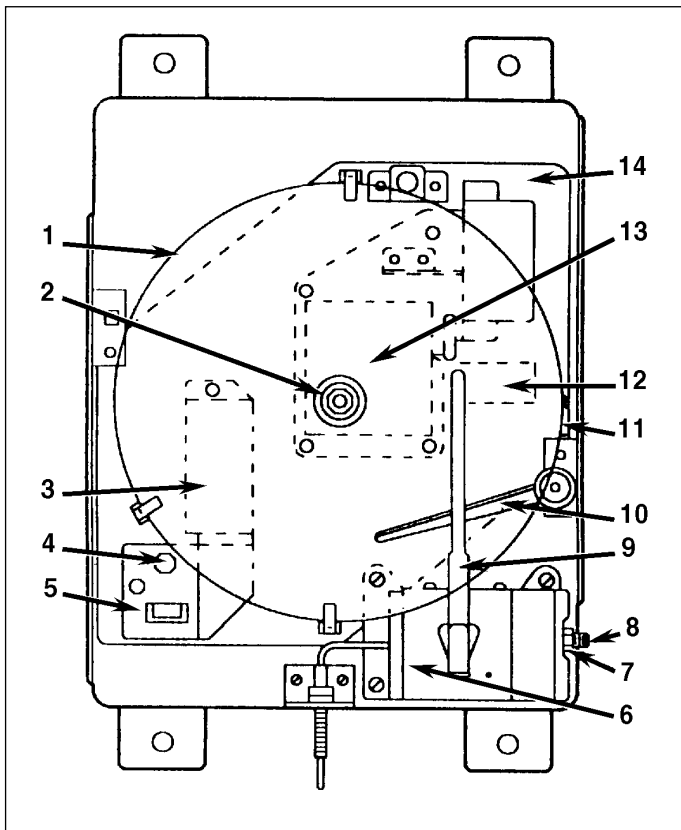

Saginomiya (SKM) Recording Thermometer

1. Recording Chart
2. Chart Nut
3. Battery
4. Test Button
5. Battery Voltage Indicator
6. Power Element Assembly
7. Setting Screw (Calibration)
8. Lock Screw (Calibration)
9. Recording Pen
10. Lifting Arm
11. Time Scale Plate
12. Terminal Board
13. Quartz Motor and Reducing Gear Assembly
14. Recording Platen

Recording Chart Replacement

1. To change the charts, raise the stylus away from the chart by rotating the pen lifting arm clockwise 30 degrees and releasing the lifting arm. The pen will remain in the raised position. Remove the knurled chart nut from the drive shaft and remove the chart.
2. Install the new chart in the slot on the platen and on the chart drive shaft. Position the chart edge under three hold-down flanges.
3. Replace the chart nut loosely and rotate the chart so that the correct date and time are indicated by the arrow on the time scale plate. Finally hold the recording chart in position and tighten the chart nut finger tight.
4. Lower the pen by rotating the lifting arm counterclockwise and pushing the pen against the chart.

Recording Stylus Calibration

1. Visually inspect the recording thermometer sensing bulb located in the evaporator near the return air grille. Make sure it is securely fastened and clear of debris.
2. Start the unit and adjust the temperature setpoint to 0 C (32 F). Operate the unit until the return air temperature reaches 0 C (32 F). Enter the View menu on the controller display and scroll to the return air temperature ("RET") screen. Press the ENTER key to lock the "RET" screen on the display.
5. Wait at least 5 minutes to allow the recording thermometer sensing bulb temperature to stabilize. Then compare the "RET" temperature in the controller display with the recording stylus of the recorder. Write down both readings.
6. If the average difference is 0.6 C (1.0 F) or less, DO NOT attempt to recalibrate.
7. If the recorder needs recalibration:
 - a. Place the pen in the recording position (lowered against chart)
 - b. Loosen the lock screw using a small Phillips screwdriver.
 - c. Adjust the setting screw with a small slotted screwdriver or a 7 mm (9/32 in.) open end wrench. Rotate the setting screw clockwise until the recording pen temperature reading is 2 to 4 C (4 to 6 F) higher than the temperature reading of the test instrument.

NOTE: Turning the setting screw one complete revolution (360 degrees) changes the temperature reading of the pen by approximately 5 C (9 F).

- d. Then rotate the setting screw counterclockwise to lower the recording pen reading until the pen reading agrees with the "RET" controller display.
 - e. Tighten the lock screw.
 - f. Wait another 5 minutes while the unit operates on Cool. Verify that the recording thermometer reading is stable and agrees with the "RET" temperature in the controller display.
 - g. Press any key to unlock the controller display screen.
6. Connect the motor wires to the terminal board. Make sure the red positive (+) and black negative (-) wire are correctly aligned.
 7. Check to see that the quartz motor is running. Look through the inspection window and make sure the internal flywheel on the quartz motor is revolving.
 8. Replace the recording platen, recording chart and chart nut. Lower the recording pen.

Power Element Assembly Replacement

The recording thermometer's power element is field replaceable. To replace the element assembly:

1. Raise the stylus away from the chart. Remove the knurled chart nut and chart.
2. Remove the recording platen.
3. Loosen five mounting screws that mount the capillary holding plate and element assembly in the recorder. Remove the power element assembly (includes recording pen assembly).
4. Remove the old sensing bulb and capillary from the unit.
5. Install the new sensing bulb and capillary in the unit. The capillary of the new thermal element may be bent, but DO NOT bend the bulb.
6. Install the capillary in the recorder and securely tighten five mounting screws.
7. Replace the recording platen, recording chart and chart nut. Lower the recording pen.
8. Check the calibration of the recorder. Recalibrate the recorder if necessary.

Timer (Quartz Motor and Reducing Gear) Replacement

The quartz motor is field replaceable. To replace the motor and reducing gear assembly:

1. Raise the stylus away from the chart. Remove the knurled chart nut and chart.
2. Remove the recording platen.
3. Loosen the two terminal screws on the terminal board and remove the motor wires.
4. Loosen the five screws that mount the motor assembly in the recorder. Remove the motor assembly.
5. Install new motor assembly. Install and securely tighten five mounting screws.

Battery Voltage Indicator

The battery voltage indicator is field replaceable. If the indicator needle oscillates when the test button is depressed, or the needle remains in the red zone when a new battery is installed, replace the voltage indicator assembly:

1. Remove the knurled chart nut and chart. Remove the recording platen.
2. Loosen the two terminal screws on the terminal board and remove the voltage indicator wires.
3. Loosen the two mounting screws that mount the voltage indicator assembly in the recorder. Remove the voltage indicator (includes battery holder).
4. Install a new voltage indicator. Install and securely tighten the two mounting screws.
5. Connect the voltage indicator wires to the terminal board. Make sure the red positive (+) wire and black negative (-) wire are correctly aligned.
6. Reinstall the battery in the battery holder (with correct polarity). Check the voltage indicator by depressing the test button to make sure the indicator needle is in the blue zone. Also check to see that the quartz motor is operating (flywheel revolving).
7. Replace the recording platen, recording chart and chart nut. Lower the recording pen.

Humidify System (Option)

The Humidify Mode increases the humidity level in the container by injecting atomized water directly into the evaporator supply air stream. The use of the Humidify Mode should be established by the shipper. The Humidify Mode option is turned on from the Program menu of the controller. See "Humidify Mode" on page 4-39 to set the Humidify system to ON.

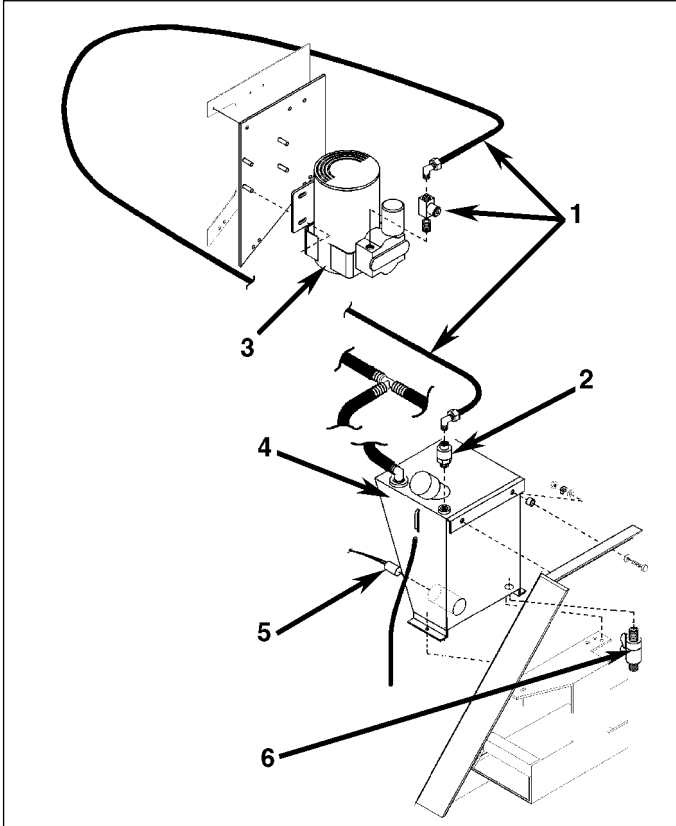

Humidify System (Option)

1. Water Supply Hose and Atomizing Nozzle: Inspect every 1,000 hours and clean if necessary.
2. Filter: Inspect every 1,000 hours and clean if necessary.
3. Air Compressor: Inspect once a year.
4. Water Tank:
 - Pretrip Inspection: Check the water level.
 - Every 1,000 Hours: Inspect the water tank and clean if necessary.
5. Water Tank Heater: Check for correct operation in ambient temperatures below 4 C (40 F).
6. Drain Cock

If the Humidify Mode is set to ON, the controller display will show "HUM" in the left display and the container humidity level (e.g. "74.5") in the right display for 1 second every 10 seconds. When the humidify function is operating (air compressor energized), the supply air LED will flash ON and OFF.

The controller energizes (operates) the air compressor when the humidity level in the container is more than 2% below the humidity setpoint. The air compressor atomizes and injects water into the evaporator supply air stream to add moisture to the container air.

The evaporator drain hoses are routed to the water tank to replenish the water level during unit operation. However, water usage will vary depending upon the load and ambient conditions. An overflow hose on the water tank removes excess water when particularly wet loads are transported or when the humidify system is not operating.

NOTE: Only demineralized or distilled water should be used to prevent plugging of the atomizing nozzle.

Pretrip Inspection

The following items should be inspected before loading the container:

- Check the water level in the water tank to maintain an adequate water supply.
- Check humidify system operation by starting the unit, setting the Humidify mode to ON and adjusting the humidify setpoint (HUMSP) more than 2% above the current humidity level in the container. Verify that the air compressor operates and that water is drawn into the atomizing nozzle and injected into the return air stream.

Inspection and Cleaning

The following items should be periodically serviced:

- Clean and inspect the filter in the water supply hose on the water tank every 1,000 operating hours. Clean the filter screen with fresh water and a soft brush.
- Inspect the water tank, water supply line and atomizing nozzle every 1,000 hours and clean if necessary. Use fresh water, a soft brush and compressed air to clean and blow clear components.
- Inspect the air compressor for signs of overheating once a year.

Mechanical Diagnosis

Condition	Possible Cause	Remedy
Compressor does not operate — no amperage draw.	Controller ON; unit start sequence still timing	Wait up to 3 minutes for compressor start-up
	No power to unit (condenser and evaporator fans do not operate)	Locate fault and repair: power source, power plug, CB1 main circuit breaker, motor contactor, motor terminals, motor
	Open in 24 Vac control circuit	Check fuses and On/Off switch. Replace or repair as required
	Container temperature does not demand compressor operation	Adjust controller setpoint
	Compressor contactor inoperative	Replace compressor contactor
	No output signal from controller output module	Diagnose and replace output module or controller
	Unit on defrost	Turn unit On/Off switch OFF and then ON again
	Defective high pressure cutout switch	Replace high pressure cutout switch
	High condenser head pressure causing high pressure cutout	Check refrigeration system and correct fault
	Defective compressor	Replace compressor
Controller shut unit down on Compressor Over Temperature (fault code 82)	Let compressor cool and controller will reset automatically. Check liquid injection valve and compressor temperature sensor	
Compressor motor internal thermal overload protection open	If compressor contactor is energized, wait 60 minutes for protector to cool and reset.	

Condition	Possible Cause	Remedy
<p>Compressor does not operate; excessive amperage draw or intermittent cycling on overload</p> <p><i>NOTE: Controller soft starts the compressor after a heat or defrost cycle, or when the unit has been off for more than 8 hours. See "Sequence of Operation" in μP-D Controller chapter</i></p>	<p>Piston stuck</p> <p>Seized or frozen compressor bearings</p> <p>Improperly wired</p> <p>Low line voltage</p> <p>High head pressure</p> <p>Contacts in compressor contactor not closing completely</p> <p>Open circuit in compressor motor winding</p> <p>Defective compressor motor internal thermal overload protector</p>	<p>Remove compressor head. Look for broken valve and jammed parts</p> <p>Replace compressor</p> <p>Check/correct wiring against wiring diagram</p> <p>Check line voltage — determine location of voltage drop</p> <p>Eliminate cause of high head pressure</p> <p>Check by operating manually. Repair or replace</p> <p>Check motor stator connections. Check stator winding for continuity. If open, replace compressor</p> <p>Replace thermal overload protector or compressor</p>
<p>Compressor contactor burned out</p>	<p>Low line voltage</p> <p>Excessive line voltage</p> <p>Short cycling</p>	<p>Increase line voltage to at least 90% of compressor motor rating</p> <p>Reduce line voltage to at least 110% of compressor motor rating</p> <p>Eliminate cause of short cycling</p>
<p>Unit short cycles</p>	<p>Controller out of calibration</p> <p>Refrigerant overcharge causing cycling on high pressure cutout</p> <p>Inefficient condenser operation causing cycling on high pressure cutout</p>	<p>Recalibrate (see Diagnosis Manual for Thermoguard μP-D Microprocessor Controller, TK 41230)</p> <p>Purge system</p> <p>Check condenser airflow, condenser fan motor, condenser fan grille, condenser fan pressure switch, water pressure switch (option), water flow rate (option) and \ water-cooled condenser-receiver tank (option)</p>

Condition	Possible Cause	Remedy
Noisy unit	<p>Insufficient compressor oil</p> <p>Loose mounting bolts</p> <p>Oil slugging or refrigerant flooding back</p> <p>Worn fan motor bearings</p> <p>Faulty compressor</p>	<p>Add oil to proper level</p> <p>Tighten mounting bolts</p> <p>Add oil or refrigerant charge. Check expansion valve adjustment</p> <p>Replace bearings or motor</p> <p>Repair or replace compressor</p>
Condenser fan motor does not operate	<p>Unit in Null, Heat or Defrost</p> <p>Unit on water-cooled condensing operation (Option)</p> <p>Unit in Cool or Modulation</p> <p>Defective condenser fan pressure switch or water pressure switch (option)</p> <p>Loose line connection</p> <p>Open motor internal thermal overload protector</p> <p>Defective motor</p> <p>Defective high speed condenser fan contactor</p> <p>No high speed condenser fan output signal from controller</p>	<p>Check indicator lights. If unit is in Null, Heat or Defrost, unit operation is normal (no remedy required)</p> <p>If condenser-receiver tank has water pressure, unit operation is normal</p> <p>Check indicator lights and discharge pressure. If condenser head pressure is below 1100 +/- 50 kPa, 11.0 +/- 0.5 bar, 160 +/- 7 psig, unit operation is normal (no remedy required)</p> <p>Replace defective switch</p> <p>Tighten connections</p> <p>Check for seized bearings or defective thermal overload protector. Repair or replace as necessary</p> <p>Replace motor</p> <p>Replace defective contactor</p> <p>Diagnose and replace output module or controller. Disconnect water supply to unit (option) and check water pressure switch (option) before replacing controller</p>

Condition	Possible Cause	Remedy
Evaporator fan motor(s) does not operate	Unit on defrost	Check operating mode indicator LEDs
	Unit in Economy Mode (Frozen Load; Null mode ONLY)	Check setpoint, indicator lights and Program menu of μ P-D controller to verify that Economy Mode is set to ON
	Loose line connection	Tighten connections
	Open motor internal thermal overload protector	Check for seized bearings or defective thermal overload protector. Repair or replace as necessary
	Defective motor	Replace motor
	Defective low or high speed evaporator fan contactor	Replace defective contactor
	No low or high speed evaporator fan output signal from controller output module	Diagnose and replace output module or controller

Refrigeration Diagnosis

Condition	Possible Cause	Remedy
<p>Unit operating in a vacuum (unit not cooling)</p> <p><i>NOTE: When the unit is in Modulation Cool or the return air temperature is below -18 C (0 F), the suction pressure will be less than 0 kPa, 0 bar, 0 psig during normal operation</i></p>	<p>Shortage of refrigerant</p> <p>Compressor motor contacts frozen</p> <p>Compressor inefficient</p> <p>Defective liquid line solenoid valve</p> <p>Partial obstruction in low side or dehydrator</p> <p>Iced or plugged evaporator coil</p> <p>Expansion valve partially closed by ice, dirt or wax</p> <p>Expansion valve power element lost its charge</p> <p>Defective container insulation</p> <p>Poor fitting container doors</p> <p>Partial obstruction in high side</p> <p>Service gauge out of calibration</p> <p>Evaporator pressure regulator (KVQ) valve stuck closed or defective</p> <p>Controller out of calibration or defective</p> <p>Expansion valve feeler bulb improperly mounted, poorly insulated or making poor contact</p>	<p>Repair leak and recharge</p> <p>Clean points or replace contactor</p> <p>Check valves and pistons</p> <p>Repair or replace liquid line solenoid valve</p> <p>Locate obstruction and repair</p> <p>Defrost or clean evaporator coil</p> <p>Clean or replace expansion valve</p> <p>Replace expansion valve</p> <p>Correct or replace container insulation</p> <p>Repair or replace doors</p> <p>Locate obstruction and repair</p> <p>Replace service gauge</p> <p>Repair or replace valve</p> <p>Recalibrate or replace controller (see Diagnosis Manual for Thermoguard μP-D Microprocessor Controller, TK 41230)</p> <p>Correct feeler bulb installation</p>

Condition	Possible Cause	Remedy
Load temperature too high (unit not cooling)	Compressor does not operate	See "Mechanical Diagnosis"
	Shortage of refrigerant	Repair leak and recharge
	Overcharge of refrigerant	Purge system
	Air in refrigeration system	Evacuate and recharge
	Controller out of calibration or defective	Recalibrate or replace controller (see Diagnosis Manual for Thermoguard μ P-D Microprocessor Controller, TK 41230)
	Controller setpoint too high	Adjust controller setpoint
	Too much compressor oil in system	Remove compressor oil from compressor
	Iced or dirty evaporator coil	Defrost or clean evaporator coil
	Restricted lines on high side	Clear restriction
	Plugged dehydrator or in-line filter	Change dehydrator or in-line filter
	Compressor inefficient	Perform compressor efficiency test. Check valves and pistons
	Evaporator pressure regulator (KVQ) valve stuck closed or defective	Repair or replace valve
	Condenser coil dirty or airflow restricted	Clean condenser coil, clear restriction, or repair or replace fan motor or condenser fan blade
	Defective condenser fan pressure switch	Replace switch
	Defective water pressure switch (Option)	Replace switch
Insufficient water flow rate or plugged water-cooled condenser-receiver tank (option)	Correct water flow rate or clean/replace condenser-receiver tank	
Expansion valve open too much	Adjust or replace valve	
Expansion valve power element lost its charge	Replace power element	
Expansion valve feeler bulb improperly mounted, poorly insulated or making poor contact	Correct feeler bulb installation	

Condition	Possible Cause	Remedy
<p>Head pressure too low</p> <p><i>NOTE: This unit has a suction modulation capacity control system. Suction and discharge pressures may drop below expected normal readings when the unit is in Modulation Cool (control temperature within 10 C [18 F] of setpoint or in Power Limit mode).</i></p>	<p>Shortage of refrigerant</p> <p>Low ambient air temperature</p> <p>Service gauge out of calibration</p> <p>Compressor suction or discharge valve inefficient</p>	<p>Repair leak and recharge</p> <p>No remedy</p> <p>Replace gauge</p> <p>Clean or replace leaking valve plates</p>
<p>Head pressure too high</p>	<p>Refrigerant overcharge</p> <p>Air in refrigeration system</p> <p>Dirty or restricted condenser coil</p> <p>Defective condenser fan pressure switch</p> <p>Defective water pressure switch (Option)</p> <p>Insufficient water flow rate or plugged water-cooled condenser-receiver tank (option)</p> <p>Condenser fan not operating</p> <p>Condenser fan grille damaged or missing</p> <p>Condenser fan blade damaged</p> <p>High ambient air temperature</p> <p>Restricted dehydrator or high side</p> <p>Defective high pressure gauge</p>	<p>Purge system</p> <p>Evacuate and recharge</p> <p>Clean condenser coil</p> <p>Replace switch</p> <p>Replace switch</p> <p>Correct water flow rate or clean/replace condenser-receiver tank</p> <p>See "Condenser fan motor does not operate" under Mechanical Diagnosis</p> <p>Repair or replace grille</p> <p>Replace fan blade</p> <p>No remedy</p> <p>Replace dehydrator or clear restriction</p> <p>Replace service gauge</p>

Condition	Possible Cause	Remedy
Compressor loses oil	Refrigerant leak	Repair leak and recharge
Compressor oil migrates to system	Short cycling	See "Unit short cycles" under Mechanical Diagnosis
Rapid cycling between Cool, Null and Heat modes	Air short cycling through evaporator Controller out of calibration Short cycling Evaporator pressure regulator (KVQ) valve stuck closed or defective	Check and correct cargo load Recalibrate or replace controller (see Diagnosis Manual for Thermoguard μ P-D Microprocessor Controller, TK 41230) See "Unit short cycles" under Mechanical Diagnosis Repair or replace valve
Hot liquid line	Shortage of refrigerant Expansion valve open too wide	Repair or recharge Adjust or replace expansion valve
Frosted liquid line	Liquid line service valve partially closed or restricted Restricted dehydrator or in-line filter	Open valve or remove restriction Replace dehydrator or in-line filter
Frosted or sweating suction line	Expansion valve admitting excess refrigerant Evaporator coil needs defrosting Evaporator fan does not operate	Check feeler bulb and adjust expansion valve Check defrost circuit including controller and evaporator coil sensor See "Evaporator fan motor does not operate" under Mechanical Diagnosis
Unit in vacuum. Frost on expansion valve only	Ice plugging expansion valve screen or orifice	Apply hot wet cloth to expansion valve. Moisture indicated by increase in suction pressure. Replace dehydrator

Condition	Possible Cause	Remedy
<p>High suction pressure</p>	<p>Overcharge of refrigerant</p> <p>Expansion valve open too much</p> <p>Controller out of calibration or defective</p> <p>Service gauge out of calibration</p>	<p>Purge system</p> <p>Adjust or replace valve</p> <p>Recalibrate or replace controller (see Diagnosis Manual for Thermoguard μP-D Microprocessor Controller, TK 41230)</p> <p>Adjust or replace service gauge</p>
<p>Low suction pressure</p> <p><i>NOTE: This unit has a suction modulation capacity control system. Suction and discharge pressures may drop below expected normal readings when the unit is on Modulation Cool (control temperature within 10 C [18 F] of setpoint or in Power Limit mode).</i></p>	<p>Shortage of refrigerant</p> <p>Low ambient air temperature</p> <p>Iced or dirty evaporator coil</p> <p>Restricted lines</p> <p>Plugged dehydrator or in-line filter</p> <p>Expansion valve closed too much</p> <p>Expansion valve feeler bulb improperly mounted, poorly insulated or making poor contact</p> <p>Evaporator fans off</p> <p>Controller out of calibration or defective</p> <p>Service gauge out of calibration</p>	<p>Repair leak and recharge</p> <p>No remedy</p> <p>Defrost or clean evaporator coil</p> <p>Locate and clear restriction</p> <p>Replace dehydrator or in-line filter</p> <p>Adjust or replace valve</p> <p>Correct feeler bulb installation</p> <p>Check evaporator fan motors and control circuit and correct fault</p> <p>Recalibrate or replace controller (see Diagnosis Manual for Thermoguard μP-D Microprocessor Controller, TK 41230)</p> <p>Adjust or replace gauge</p>

9 Electrical, Refrigeration and μ P-D Menu Flow Diagrams

460/380 Vac Power Supply to Unit

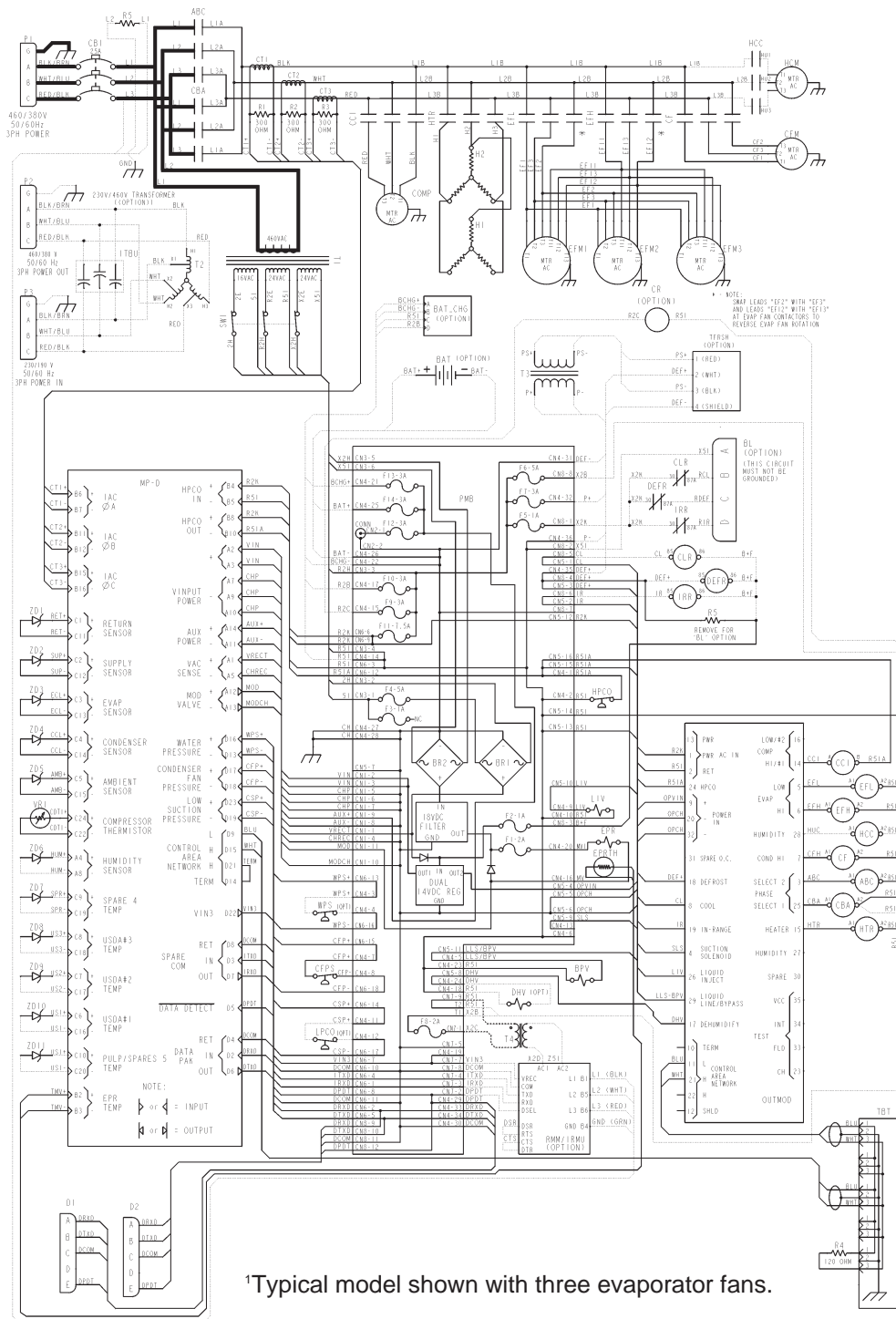

1Typical model shown with three evaporator fans.

230/190 Vac Power Supply to Unit

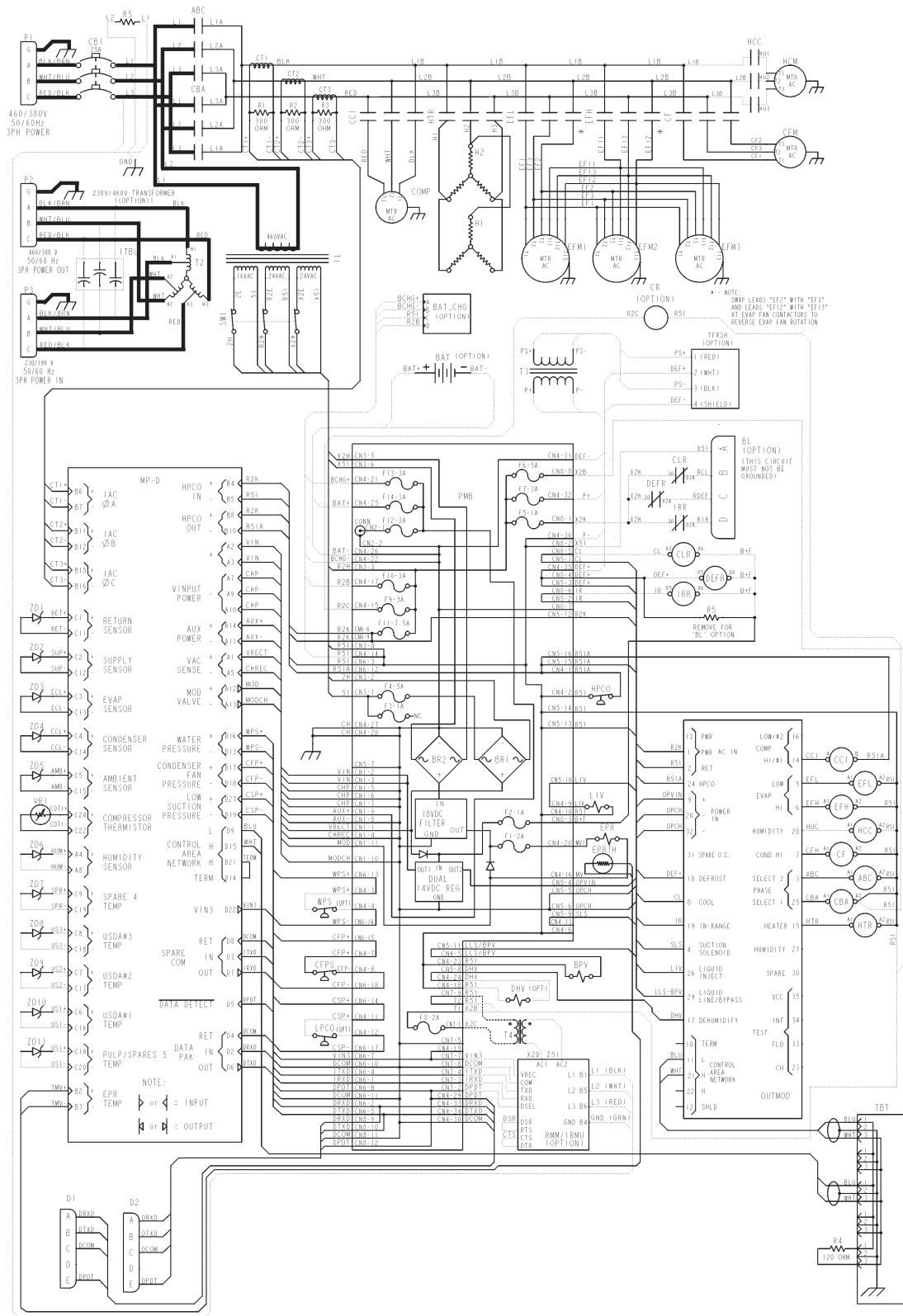

¹Typical model shown with three evaporator fans.

External 12 Vdc Battery Power Supply^{1,2}

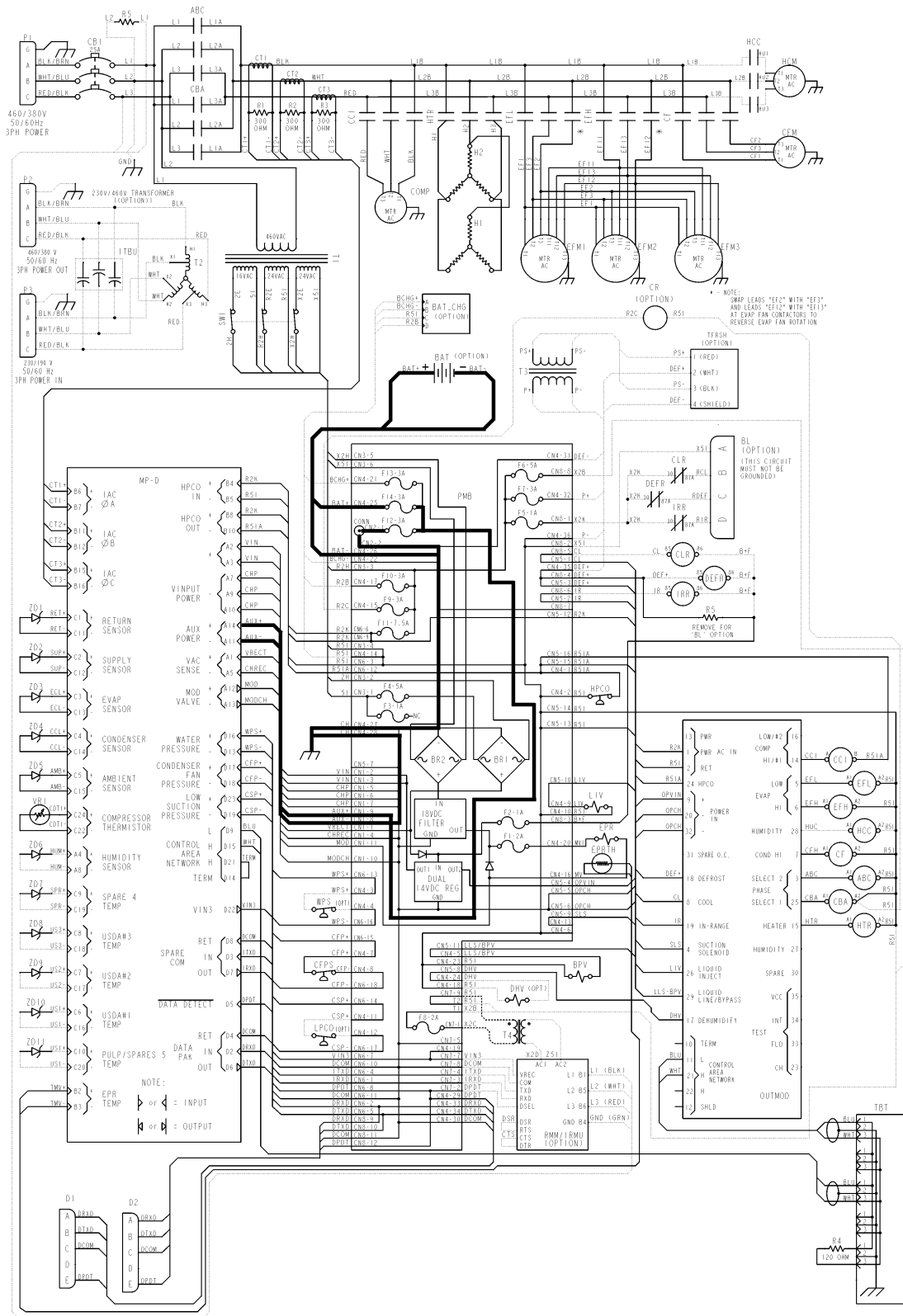

¹Typical model shown with three evaporator fans.

²Requires on-board 12 Vdc battery or an external 12 Vdc battery connected to battery jack on Power Module Board inside control box.

12.5 Vdc Control Circuit, Sensor Circuits, Evaporator Pressure Regulator (KVQ) Valve Circuit, Condenser Fan Pressure Switch Circuit and Water Pressure Circuit (Option)¹

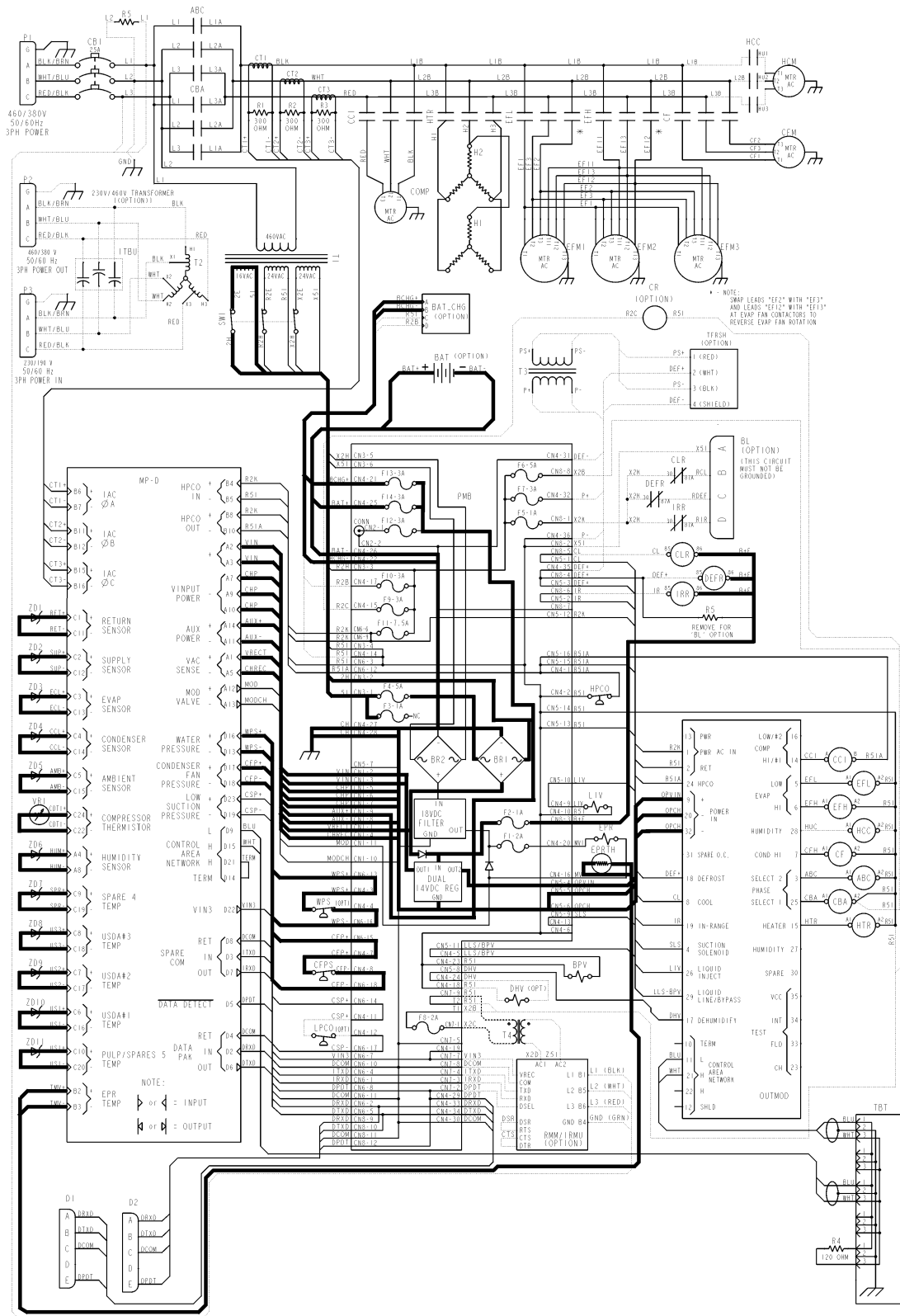

¹Typical model shown with three evaporator fans.

24 Vac Control Circuit¹

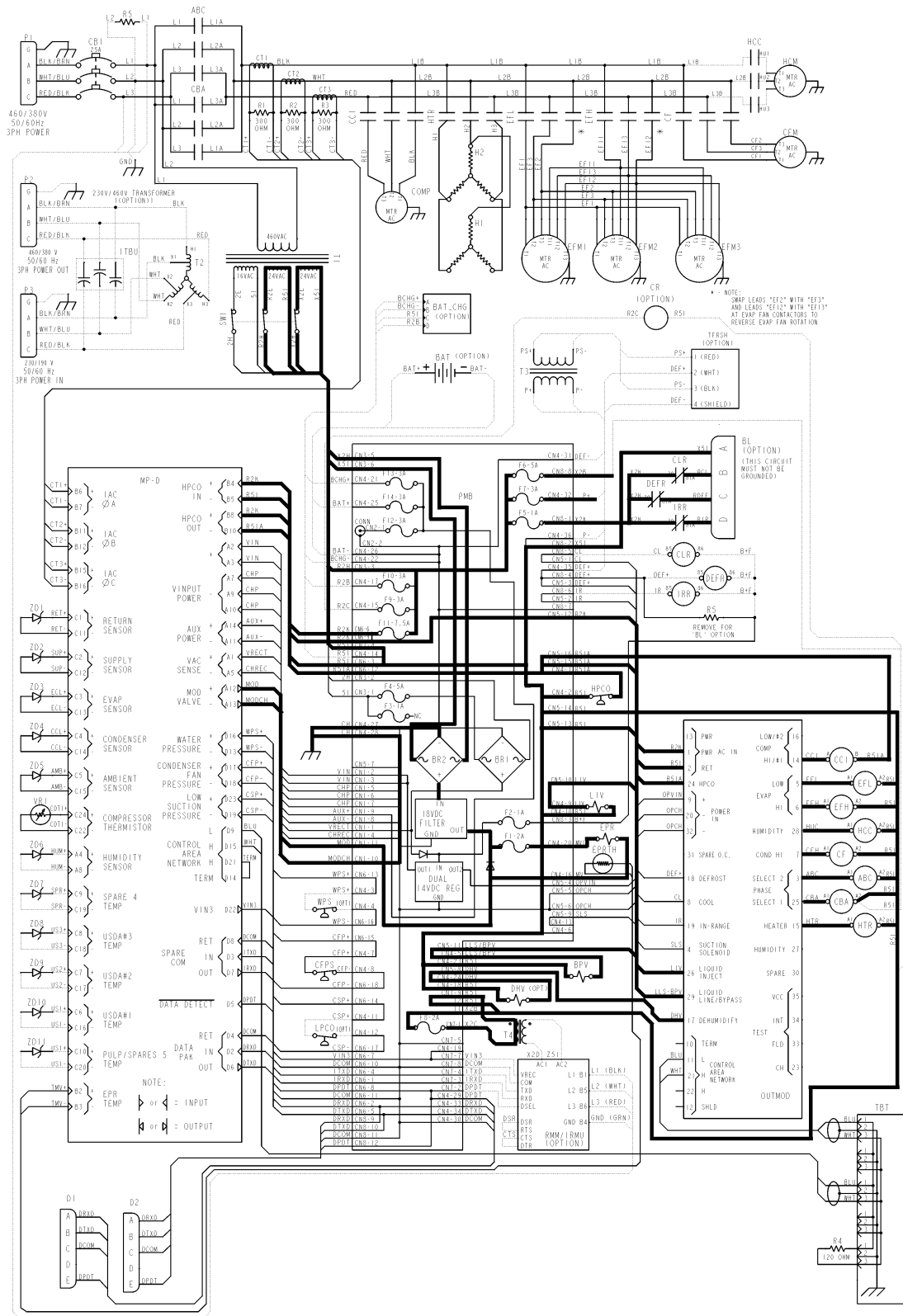

¹Typical model shown with three evaporator fans.

Setpoint Enable Battery and Battery Charger Circuit¹ (Option)

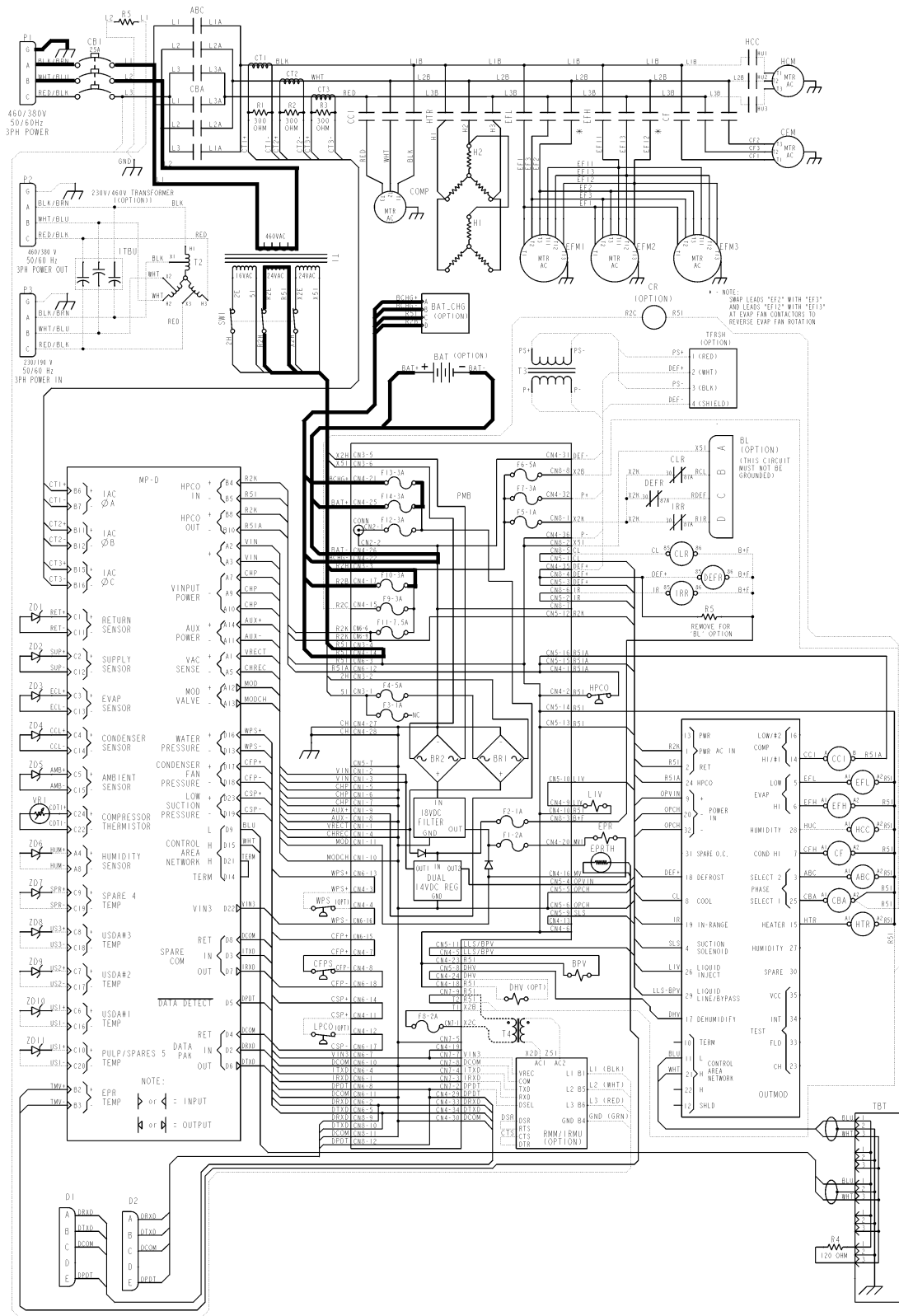

¹Typical model shown with three evaporator fans.

Remote Monitor Receptacle (4-pin) for Bridge Lights Circuit¹ (Option)

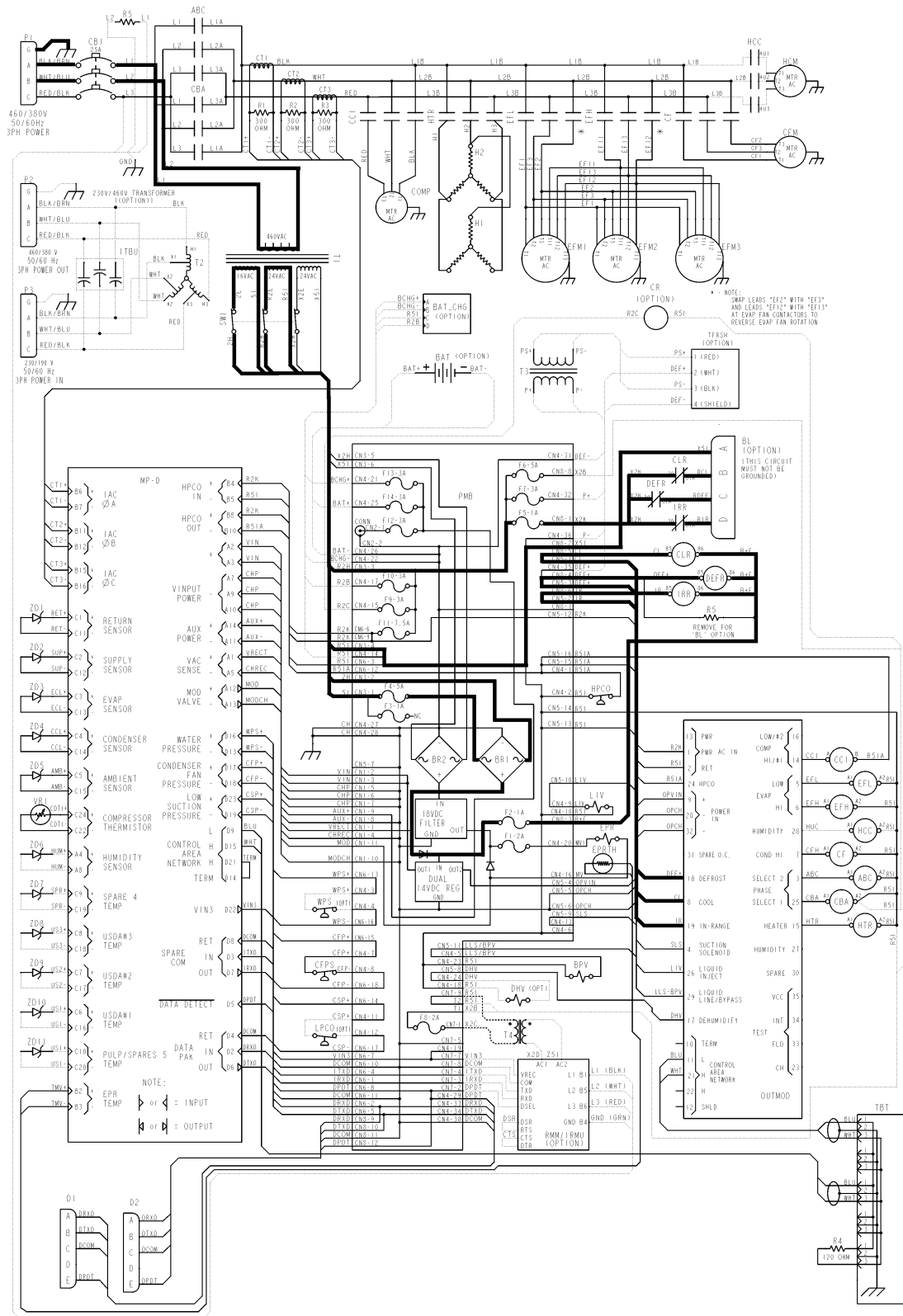

¹Typical model shown with three evaporator fans.

TRANSFRESH® Atmosphere Control System Circuit¹ (Option)

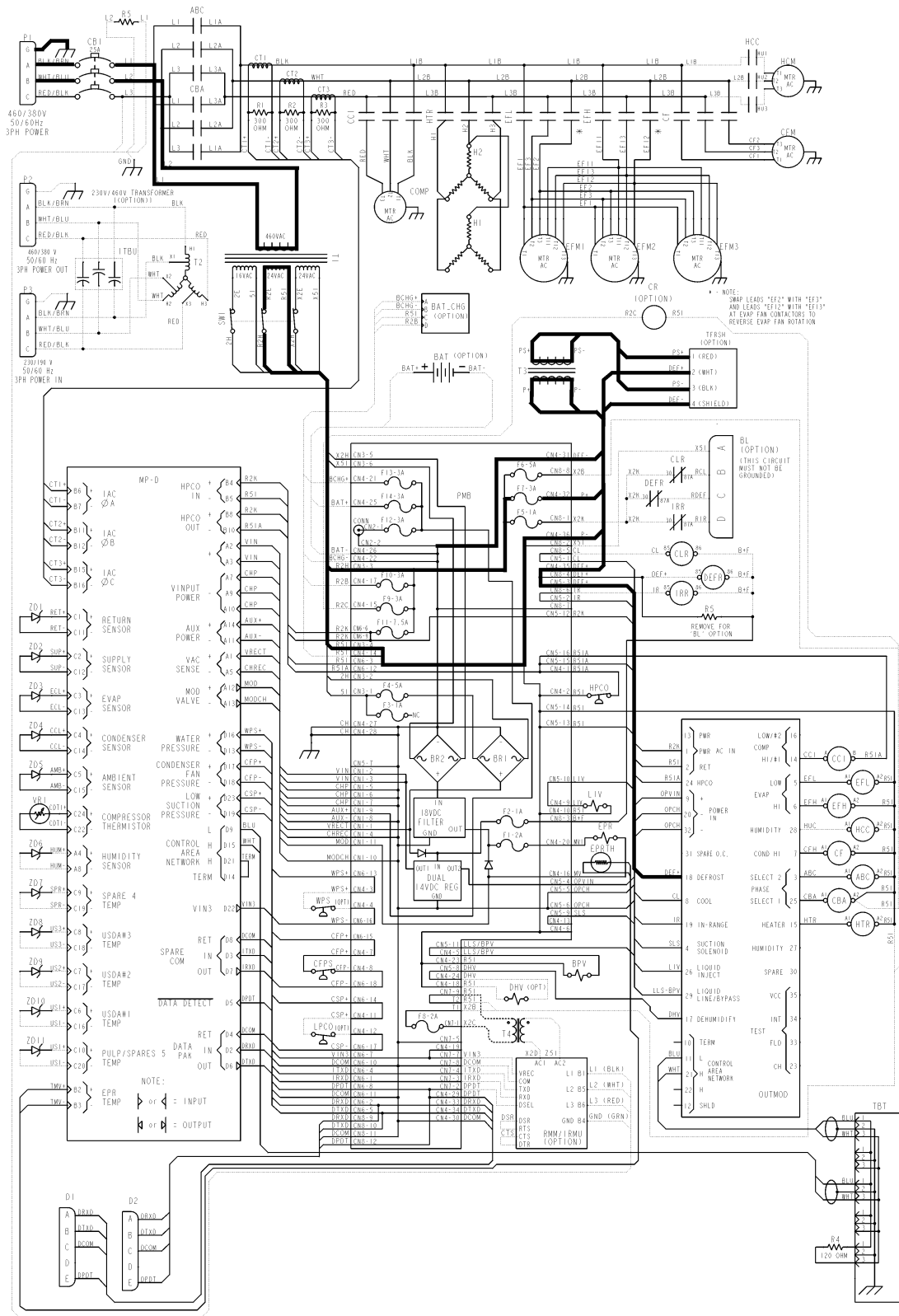

¹Typical model shown with three evaporator fans.

Integrated Remote Monitor System Circuit¹ (Option)

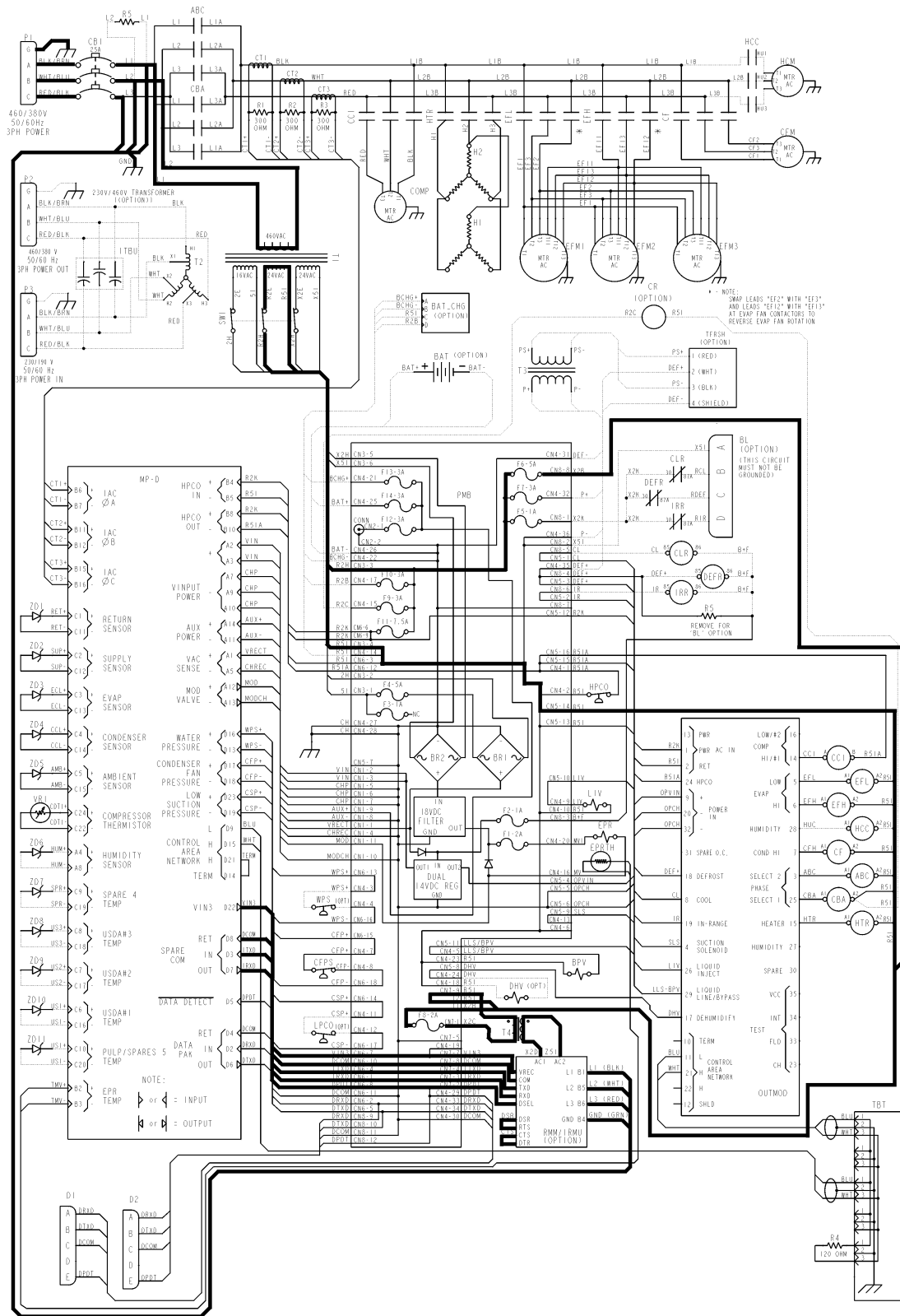

¹Typical model shown with three evaporator fans.

Cool Mode¹ — Chill Load (Setpoint at -9.9 C [14.1 F] or Above); Water-Cooled Condenser Operation²; Power Monitor Limiting Unit Power Consumption; Economy Mode OFF

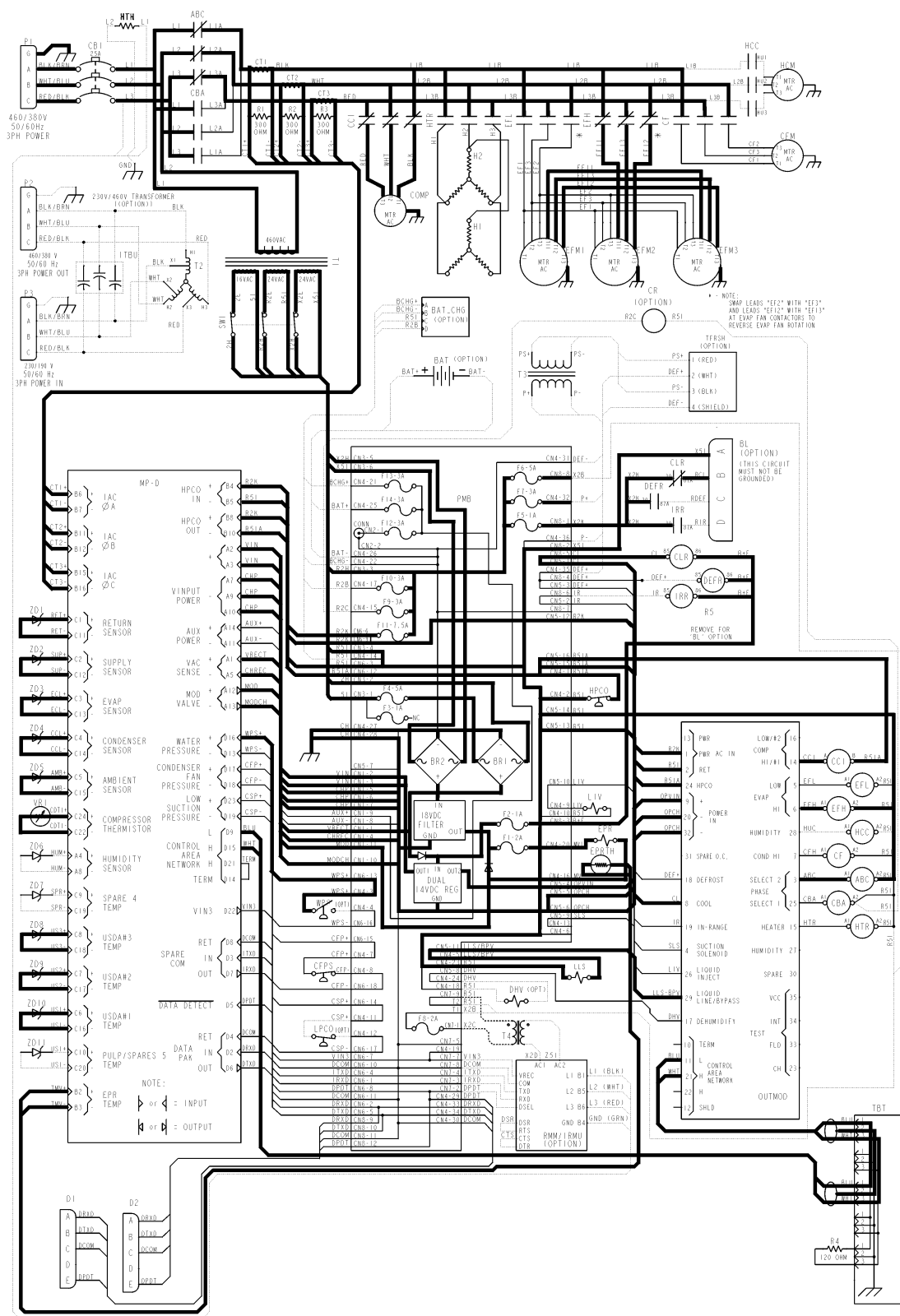

¹Typical model shown with three evaporator fans.

²When the water pressure switch opens on units with an optional water-cooled condenser-receiver tank, the condenser fan does not operate. When water pressure is disconnected from the condenser-receiver tank, condenser fan operation resumes. Standard units have a jumper wire installed in the water pressure switch harness.

Cool Mode¹ — Chill Load (Setpoint at -9.9 C [14.1 F] or Above); Condenser Fan ON²; Power Monitor Limiting Unit Power Consumption; Economy Mode OFF

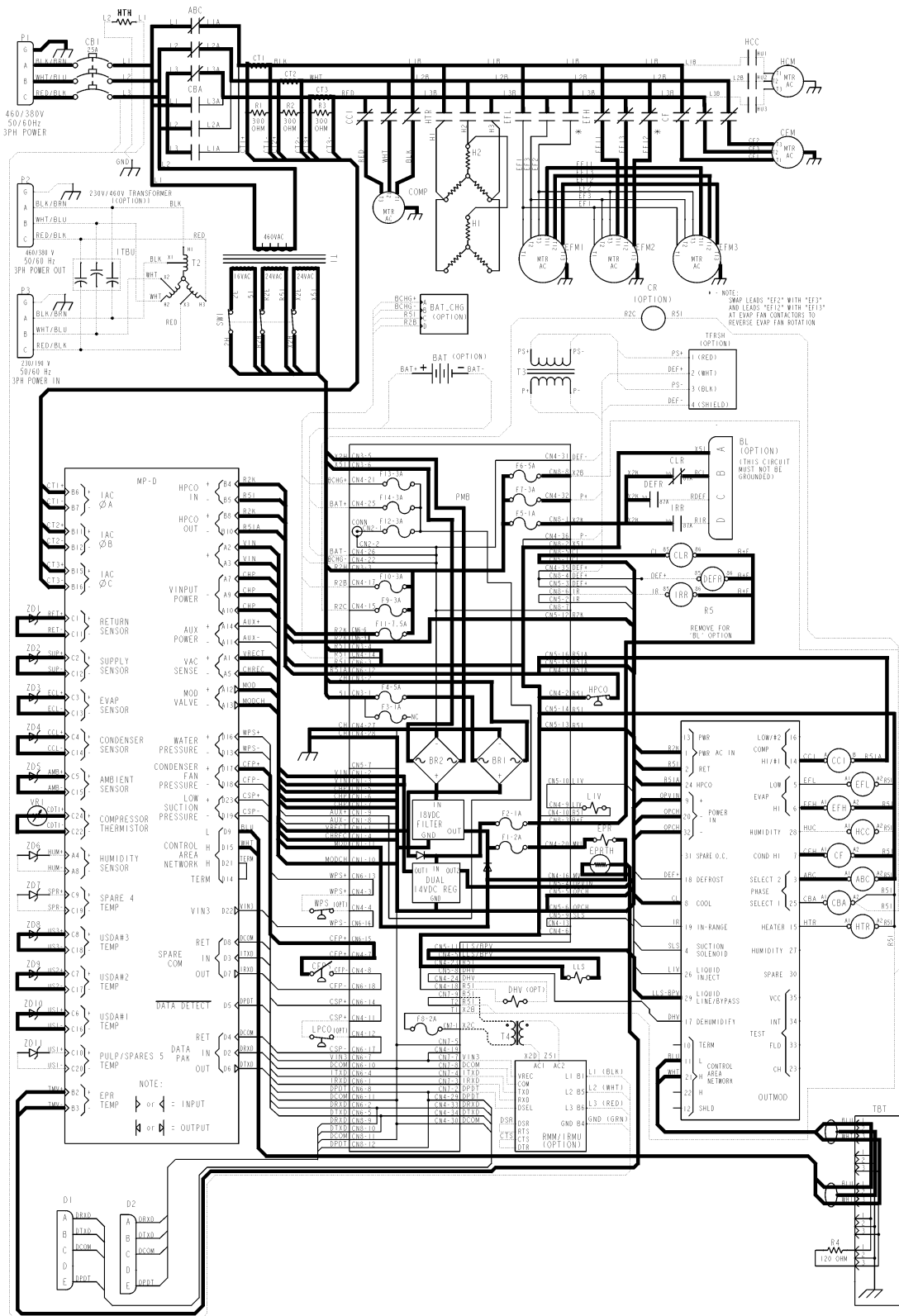

¹Typical model shown with three evaporator fans.

²Condenser fan will stop if condenser head pressure decreases to 1100 +/- 50 kPa, 11.00 +/- 0.5 bar, 160 +/- 7 psig.

Cool Mode¹ — Chill Load (Setpoint at -9.9 C [14.1 F] or Above); Condenser Fan ON²; Economy Mode OFF

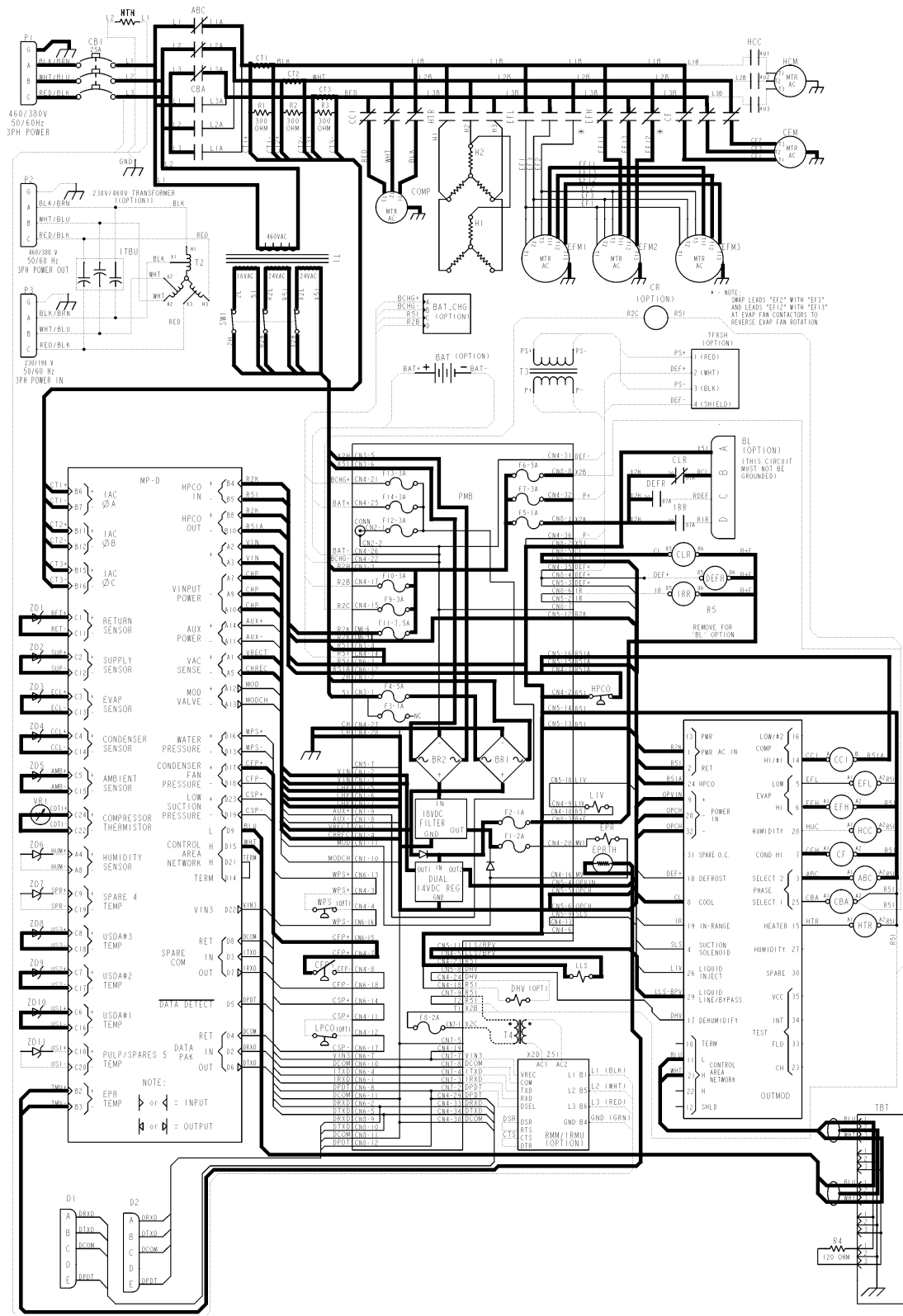

¹Typical model shown with three evaporator fans.

²Condenser fan will stop if condenser head pressure decreases to 1100 +/- 50 kPa, 11.00 +/- 0.5 bar, 160 +/- 7 psig.

Cool Mode¹ — Chill Load (Setpoint at -9.9 C [14.1 F] or Above); Condenser Fan ON²; Economy Mode OFF; Humidify Mode (Option) ON with container humidity above humidity setpoint

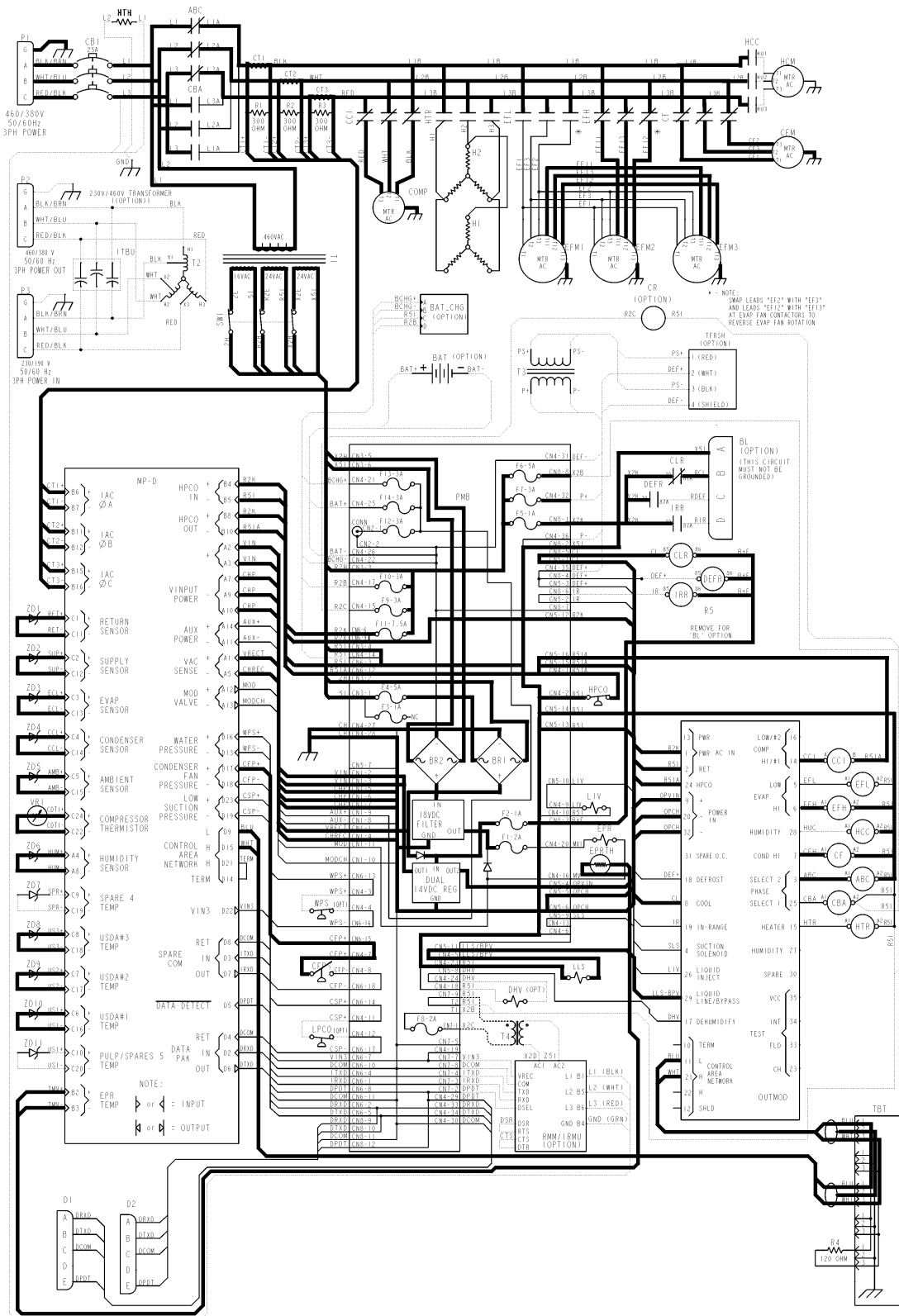

¹Typical model shown with three evaporator fans.

²Condenser fan will stop if condenser head pressure decreases to 1100 +/- 50 kPa, 11.00 +/- 0.5 bar, 160 +/- 7 psig.

Cool Mode¹ — Chill Load (Setpoint at -9.9 C [14.1 F] or Above); Condenser Fan ON²; Economy Mode OFF; Humidify Mode (Option) ON with container humidity more than 2% below the humidity setpoint

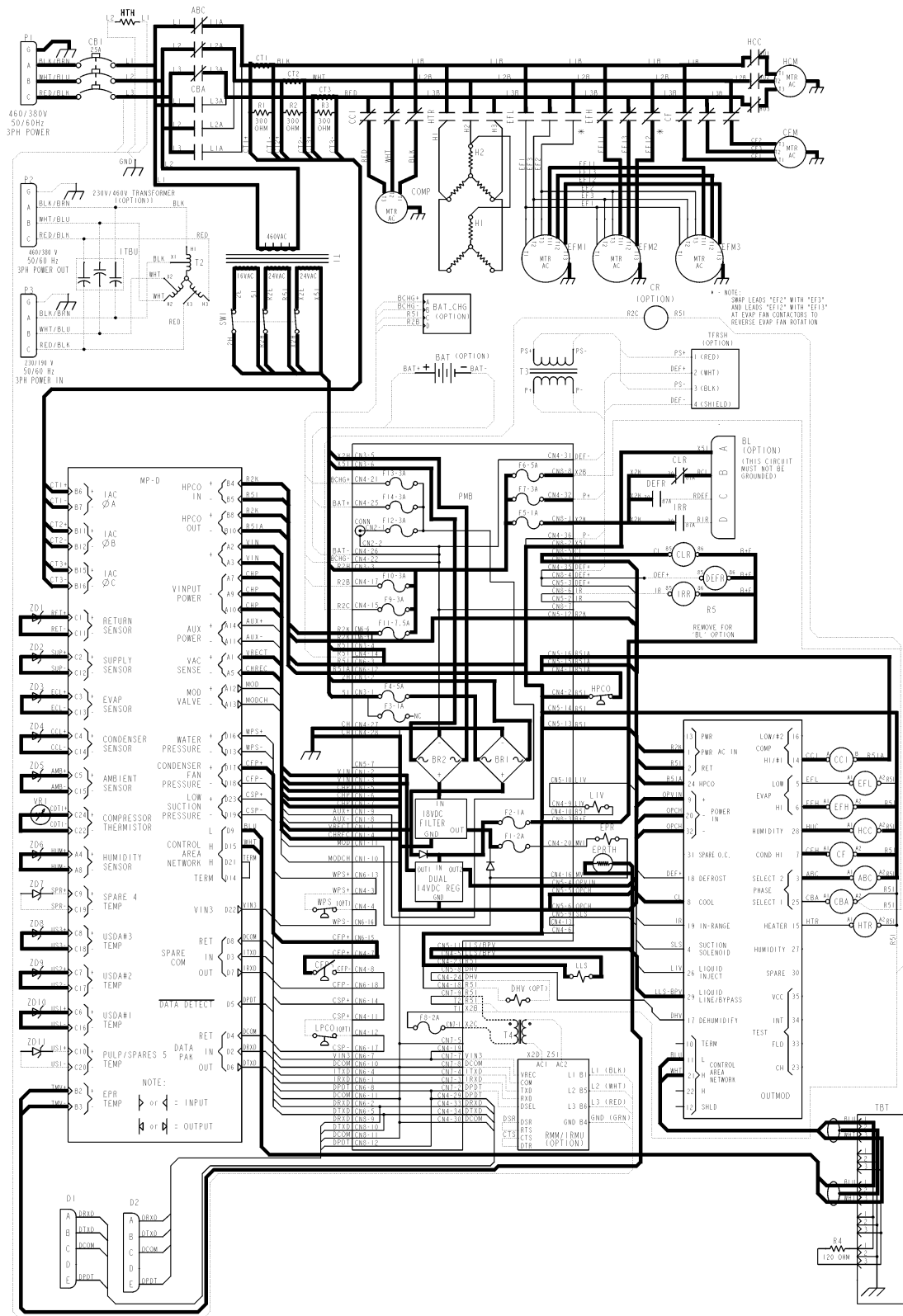

¹Typical model shown with three evaporator fans.

²Condenser fan will stop if condenser head pressure decreases to 1100 +/- 50 kPa, 11.00 +/- 0.5 bar, 160 +/- 7 psig.

Modulation Mode¹ — Chill Load (Setpoint at -9.9 C [14.1 F] or Above); Condenser Fan ON²; Economy Mode OFF; Temperature Out-of-range

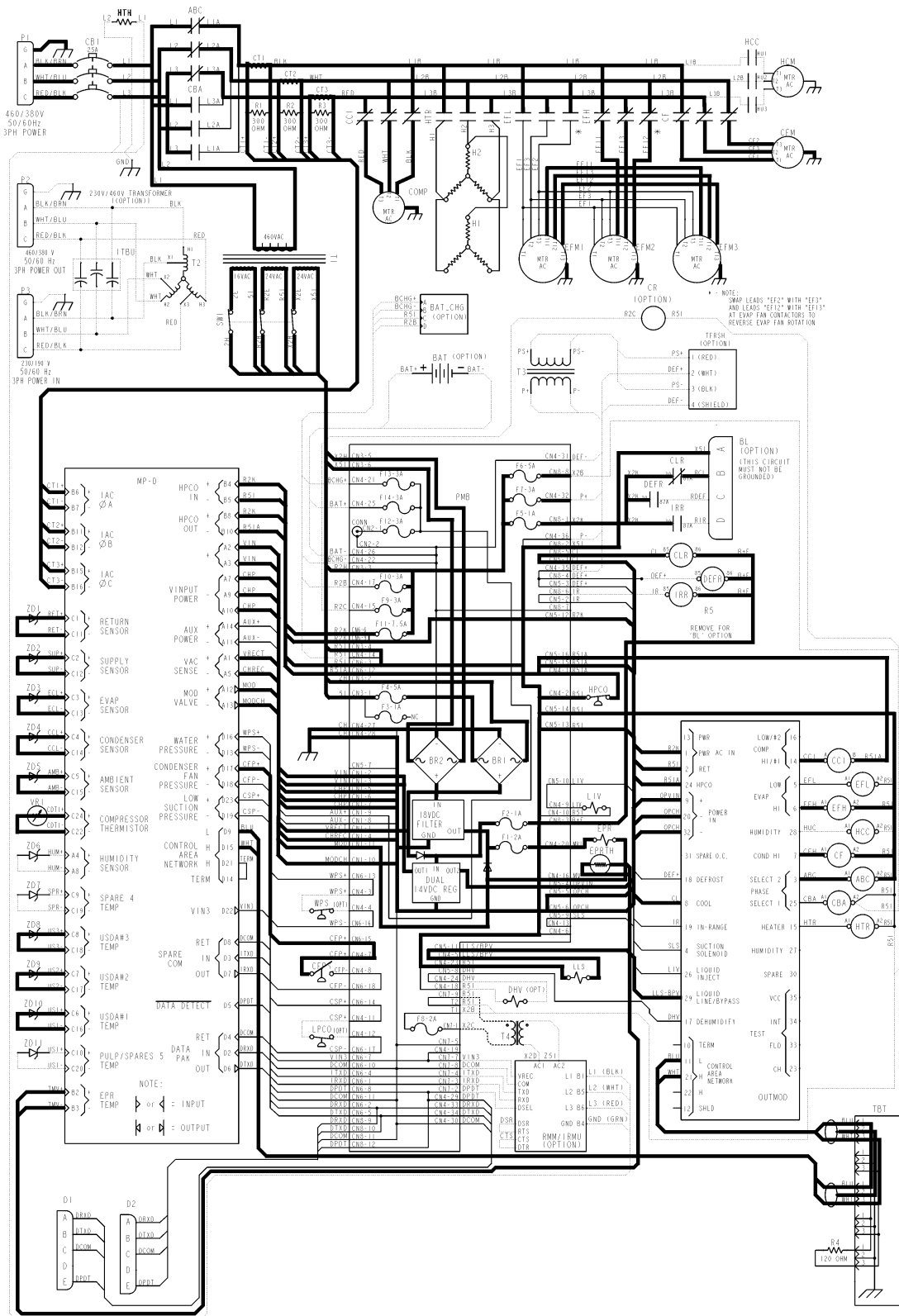

¹Typical model shown with three evaporator fans.

²Condenser fan will stop if condenser head pressure decreases to 1100 +/- 50 kPa, 11.00 +/- 0.5 bar, 160 +/- 7 psig.

Modulation Mode¹ — Chill Load (Setpoint at -9.9 C [14.1 F] or Above); Condenser Fan ON²; Economy Mode OFF; Temperature In-range; Dehumidify ON with Humidity 1-5% Above Humidity Setpoint³

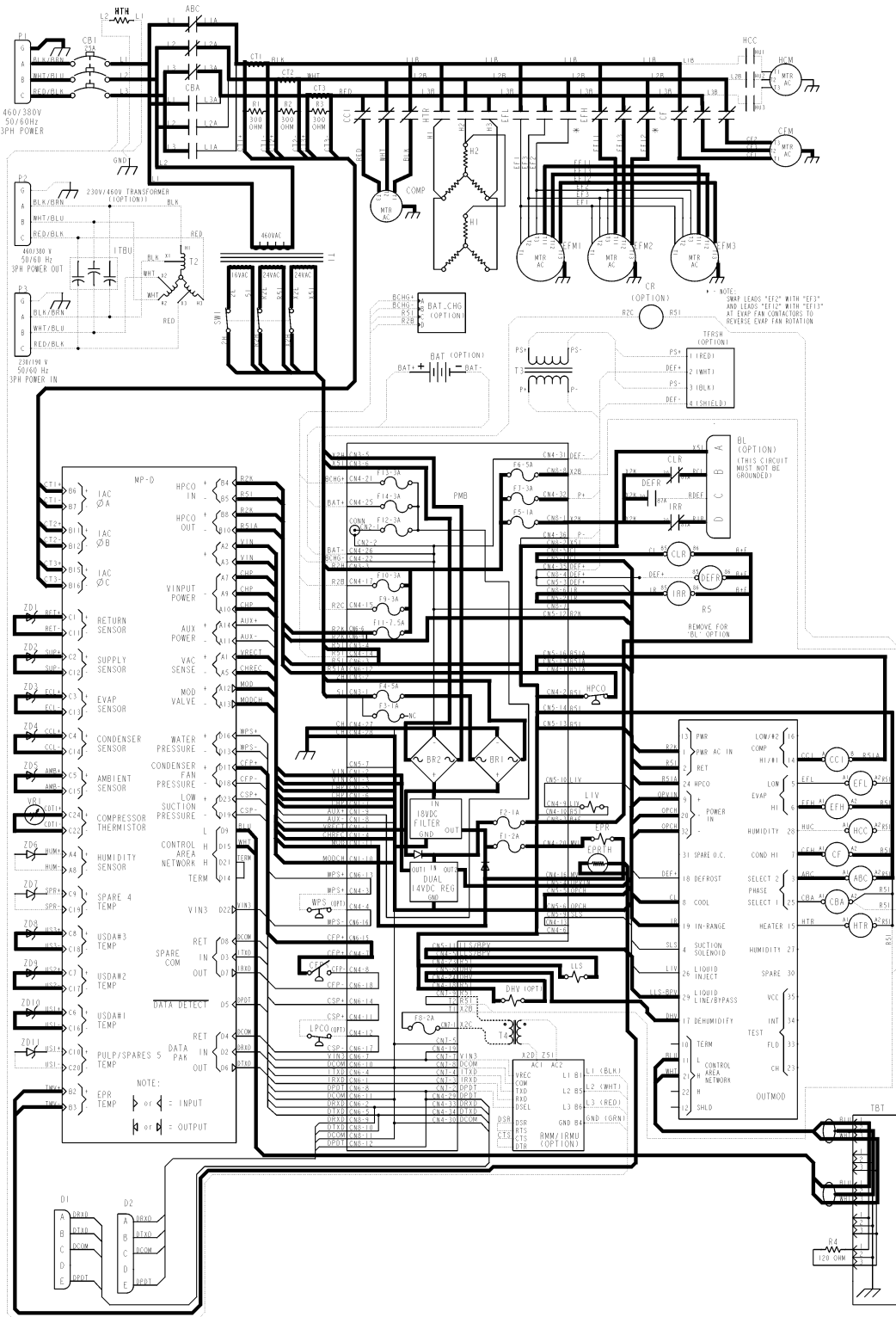

¹Typical model shown with three evaporator fans.

²Condenser fan will stop if condenser head pressure decreases to 1100 +/- 50 kPa, 11.00 +/- 0.5 bar, 160 +/- 7 psig.

³Dehumidify Mode is set to ON in the PROGRAM menu of the controller. When the unit is in Low Dehumidify operation (humidity 1-5% above setpoint), the dehumidify valve closes (energizes) to reduce the size of the evaporator coil used for cooling.

Modulation Mode¹ — Chill Load (Setpoint at -9.9 C [14.1 F] or Above); Condenser Fan ON²; Economy Mode OFF; Temperature In-range; Dehumidify ON with Humidity 5% or More Above Humidity Setpoint³

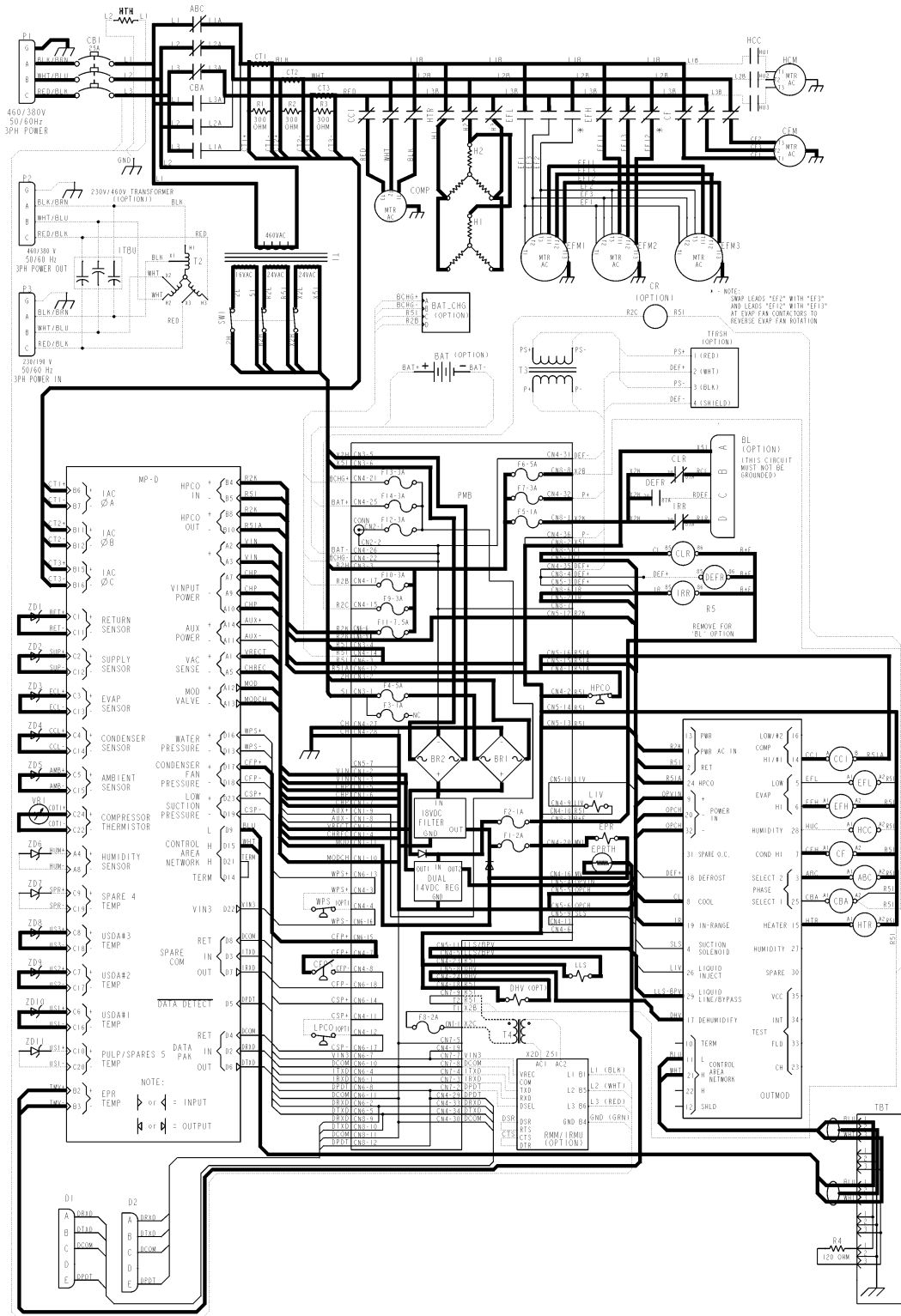

¹Typical model shown with three evaporator fans.

²Condenser fan will stop if condenser head pressure decreases to 1100 +/- 50 kPa, 11.00 +/- 0.5 bar, 160 +/- 7 psig.

³Dehumidify Mode is set to ON in the PROGRAM menu of the controller. When the unit is in High Dehumidify operation (5% or more above setpoint), the dehumidify valve closes (energizes) to reduce the size of the evaporator coil used for cooling and the electric heaters are pulsed ON for a maximum of 15 seconds every 30 seconds.

Modulation Mode¹ — Chill Load (Setpoint at -9.9 C [14.1 F] or Above); Condenser Fan OFF²; Economy Mode ON³; Temperature In-range

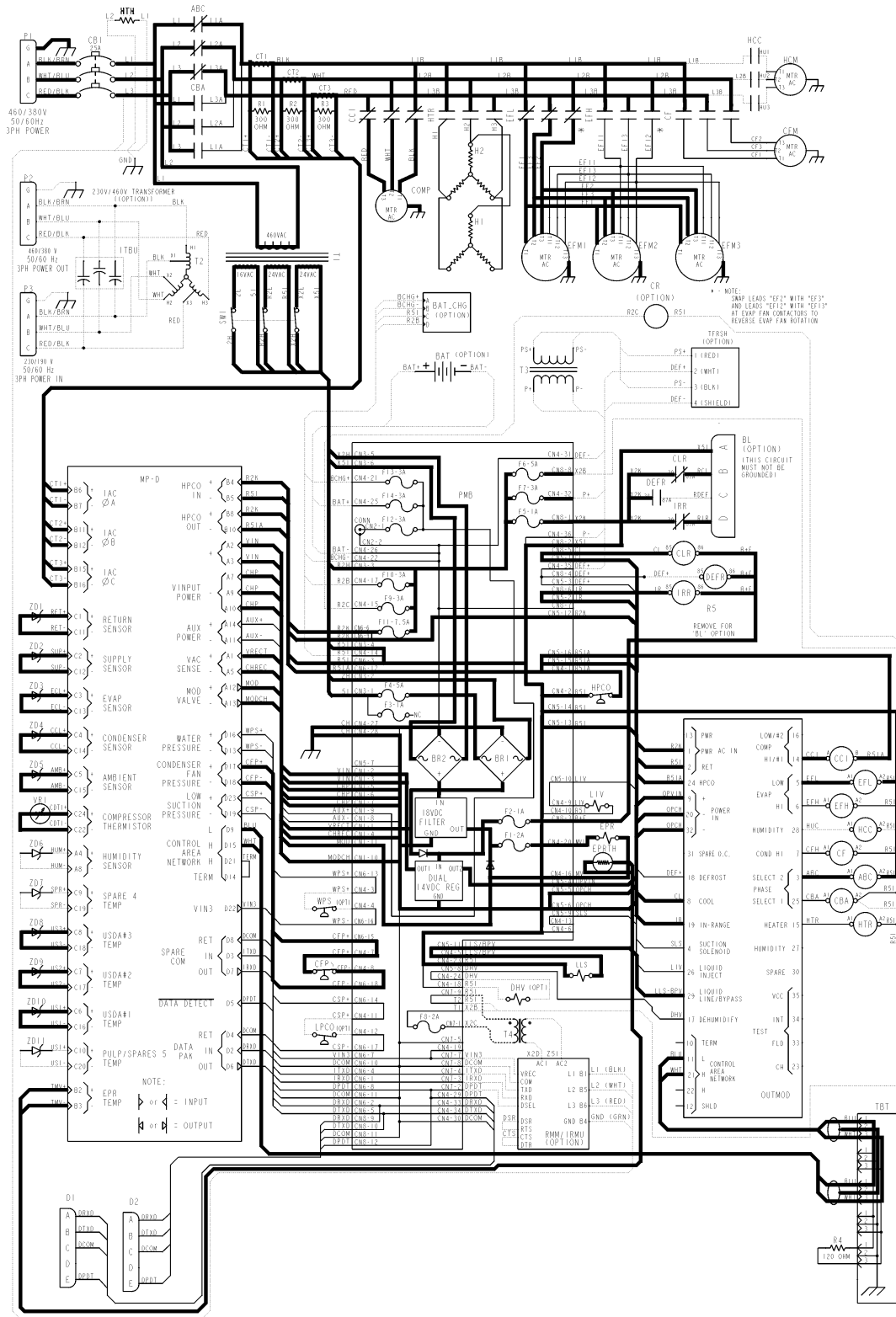

¹Typical model shown with three evaporator fans.

²Condenser fan will stop if condenser head pressure decreases to 1100 +/- 50 kPa, 11.00 +/- 0.5 bar, 160 +/- 7 psig.

³Evaporator fans operate on low speed when Economy Mode is set to ON in the Program menu of the μ P-D controller and the container temperature is In-range.

Null Mode¹ — Chill Load (Setpoint at -9.9 C [14.1 F] or Above) During Compressor Pump Down (Condenser Fan ON)²; Economy Mode OFF

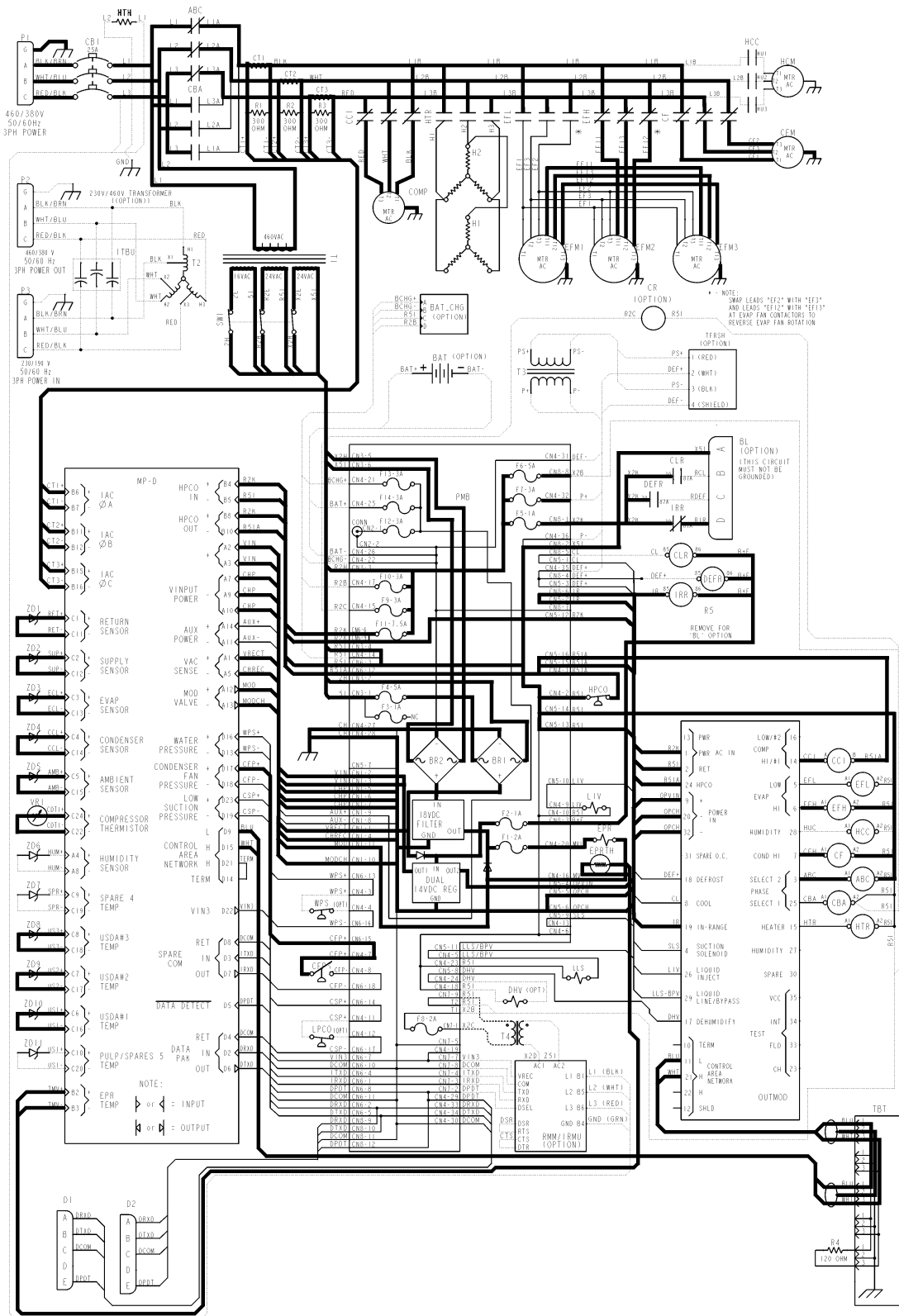

¹Typical model shown with three evaporator fans.

²The microprocessor closes (de-energizes) the liquid line solenoid valve while the compressor continues to operate. Controller stops compressor to terminate pump down cycle on time limit after 60 seconds. If the condenser fan was ON, it will operate for approximately 30 seconds and then stop.

Heat Mode^{1,2} — Chill Load (Setpoint at -9.9 C [14.1 F] or Above); Economy Mode OFF; Temperature In-range

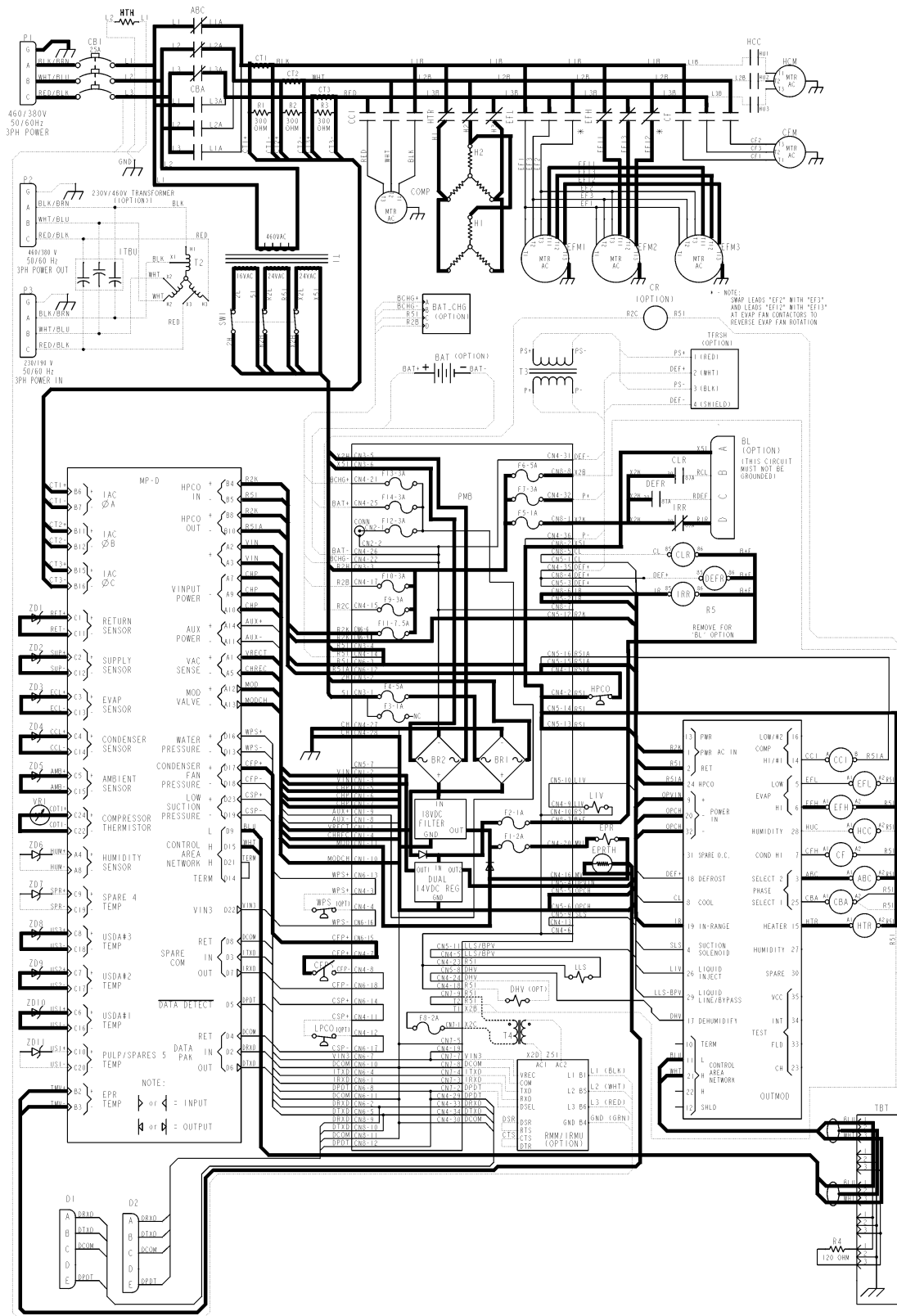

¹Typical model shown with three evaporator fans.

²Electric heaters pulse ON and OFF during the Heat mode. The amount of ON time increases from 0% at a Calculated Temperature Differential of 0.6 C (1.0 F) below setpoint to 100% at a Calculated Temperature Differential of 3.1 C (5.5 F) below setpoint.

Cool Mode¹ — Frozen Load (Setpoint at -10.0 C [14.0 F] or Below); Condenser Fan ON²; Container Return Air Temperature Above -10.0 C (14.0 F); Power Monitor Limiting Unit Power Consumption; Economy Mode OFF

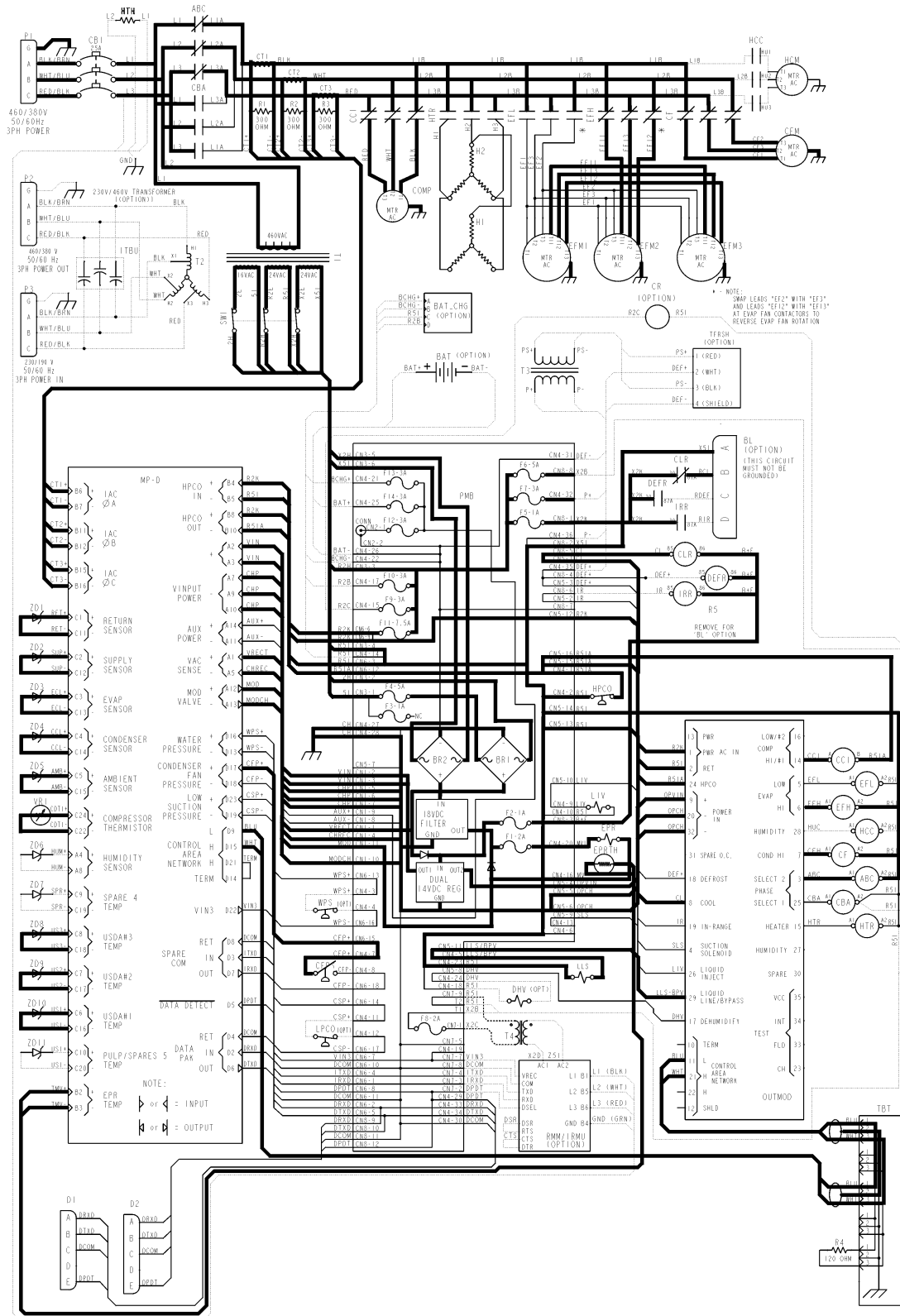

¹Typical model shown with three evaporator fans.

²Condenser fan will stop if condenser head pressure decreases to 1100 +/- 50 kPa, 11.00 +/- 0.5 bar, 160 +/- 7 psig.

Cool Mode¹ — Frozen Load (Setpoint at -10.0 C [14.0 F] or Below); Condenser Fan ON²; Container Return Air Temperature Below -10.0 C (14.0 F); Economy Mode OFF; Temperature In-Range

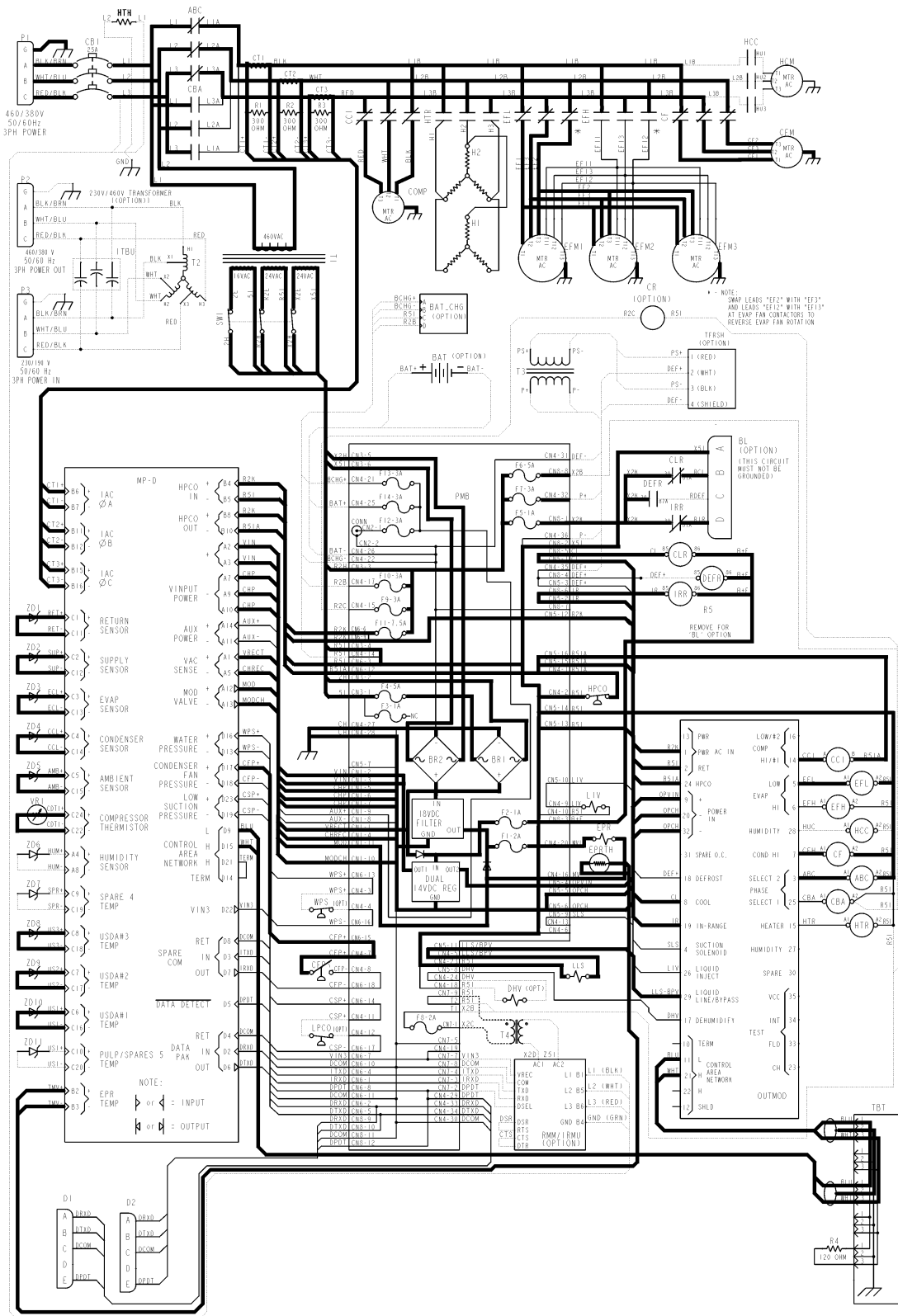

¹Typical model shown with three evaporator fans.

²Condenser fan will stop if condenser head pressure decreases to 1100 +/- 50 kPa, 11.00 +/- 0.5 bar, 160 +/- 7 psig.

Null Mode¹ — Frozen Load (Setpoint at -10.0 C [14.0 F] or Below); After Compressor Pump Down; Economy Mode OFF

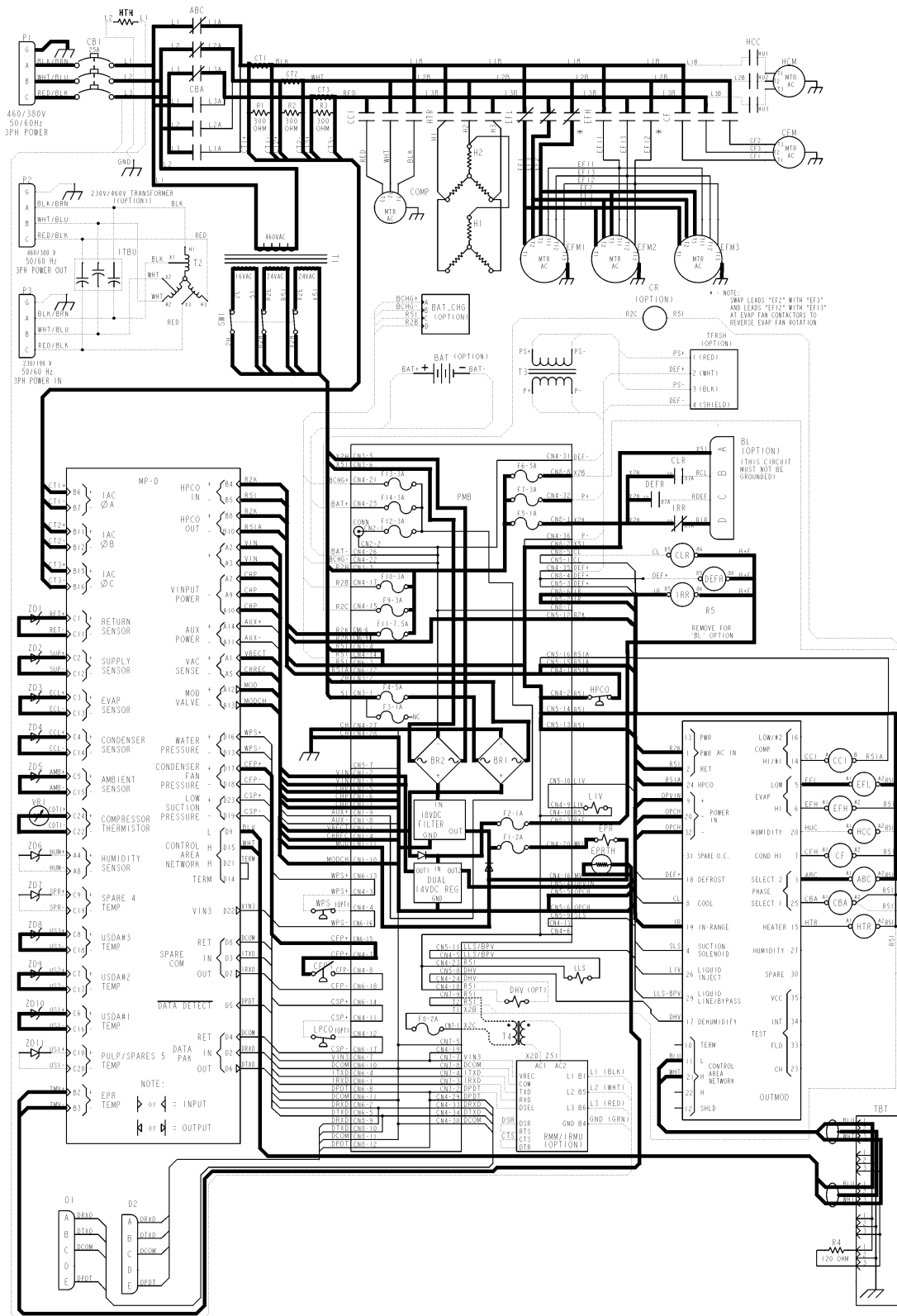

¹Typical model shown with three evaporator fans.

²Controller stops the compressor. If the condenser fan was ON, it will operate for 30 seconds and then stop.

Null Mode¹ — Frozen Load (Setpoint at -10.0 C [14.0 F] or Below); After Compressor Pump Down; Economy Mode ON³

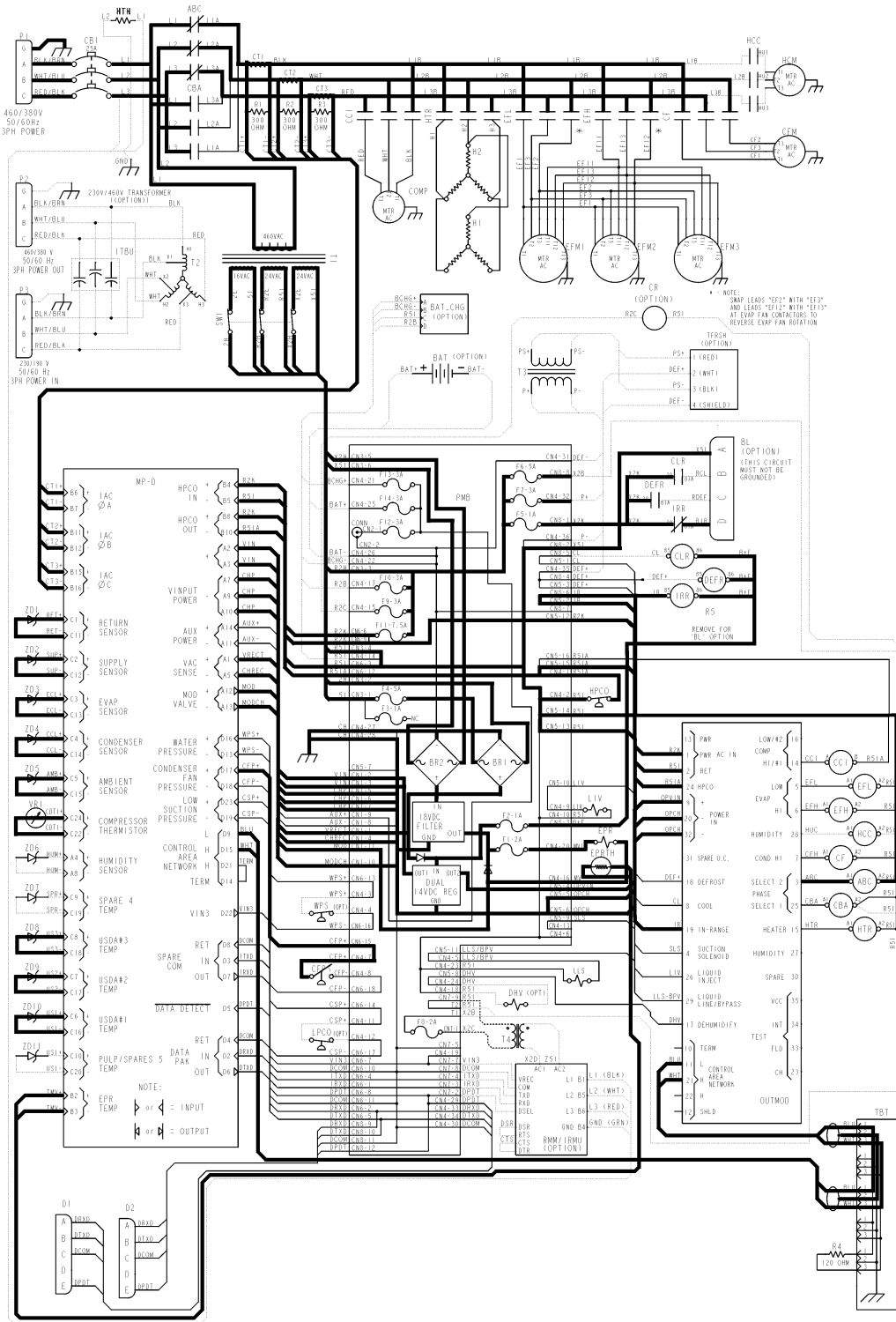

¹Typical model shown with three evaporator fans.

²Evaporator fans stop during Null mode when Economy Mode is set to ON in the Program menu of the μ P-D controller. During Economy Mode operation, a Null state timer automatically starts and operates the evaporator fans on low speed for 5 minutes every 45 minutes. The unit remains in Null until the return air temperature increases to 1.0 C (1.8 F) above setpoint at the expiration of a 45 minute Null state time sequence.

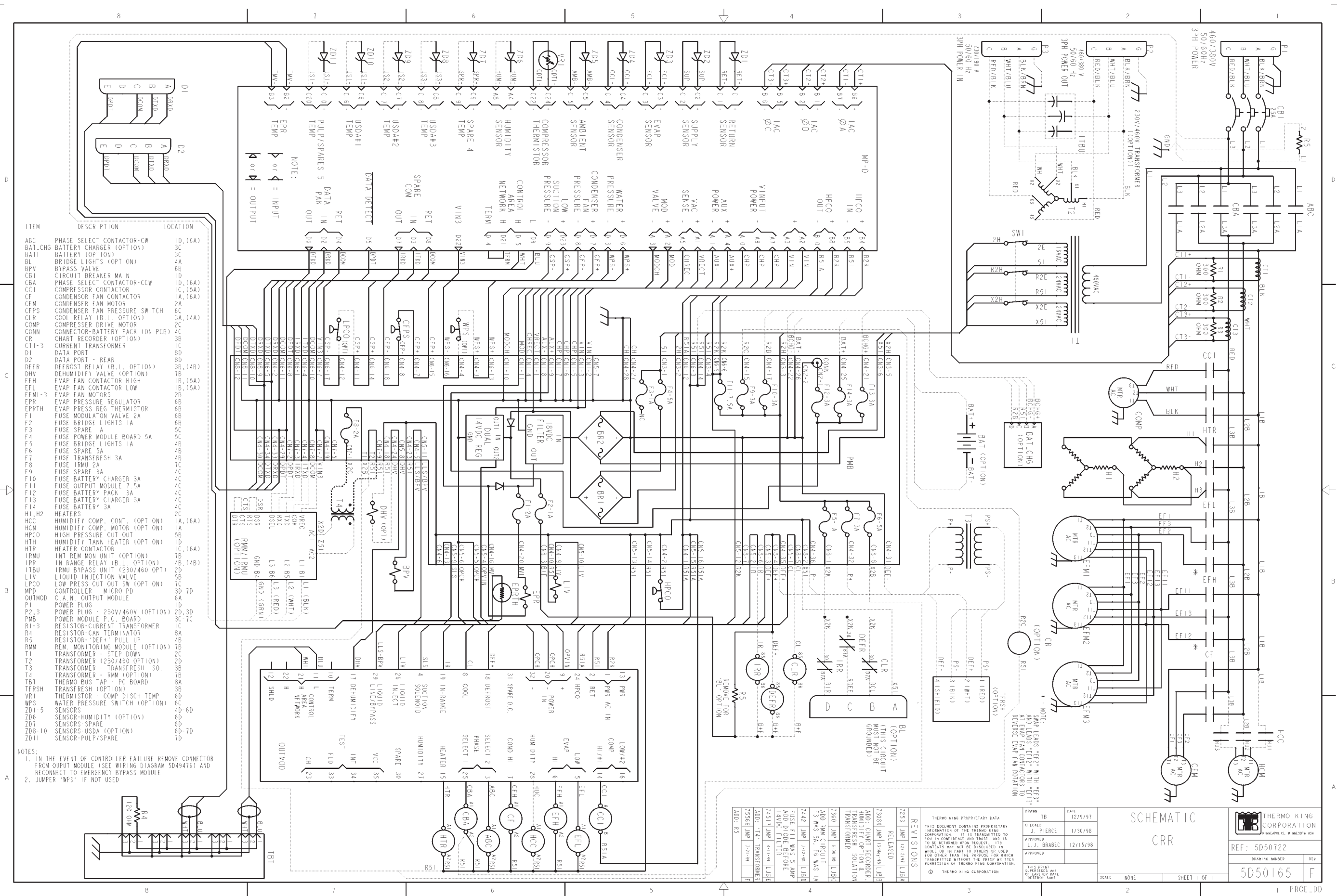

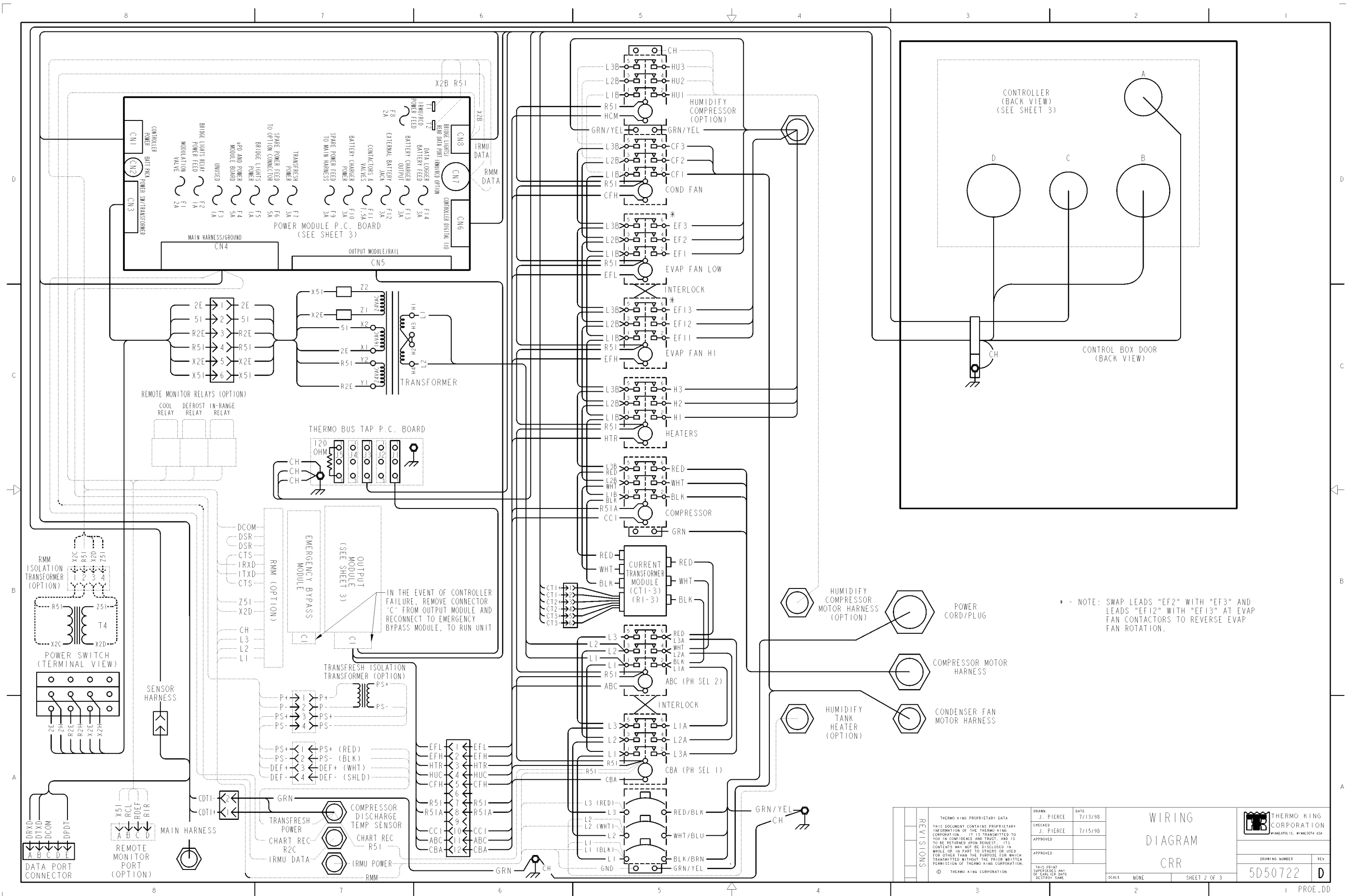

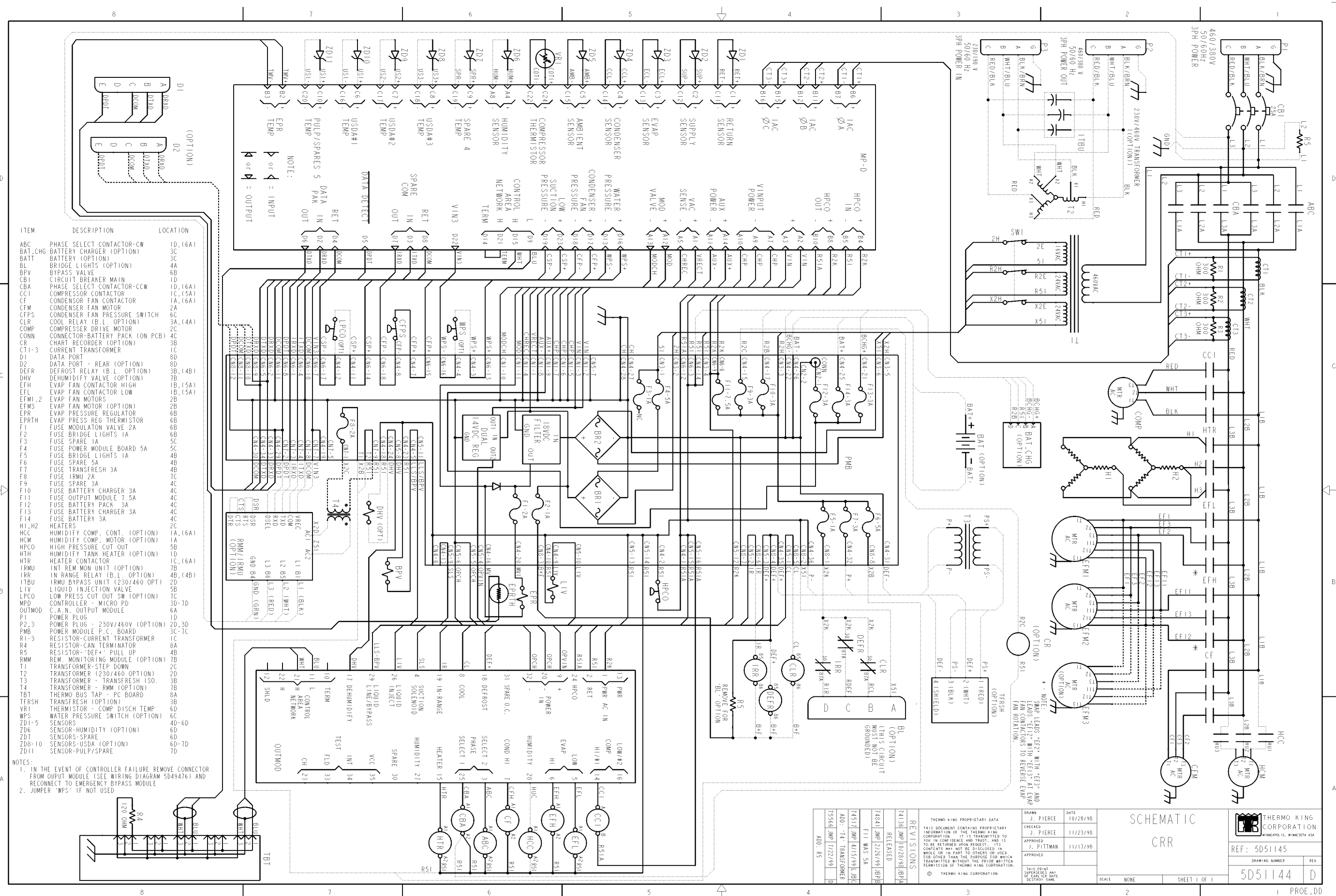

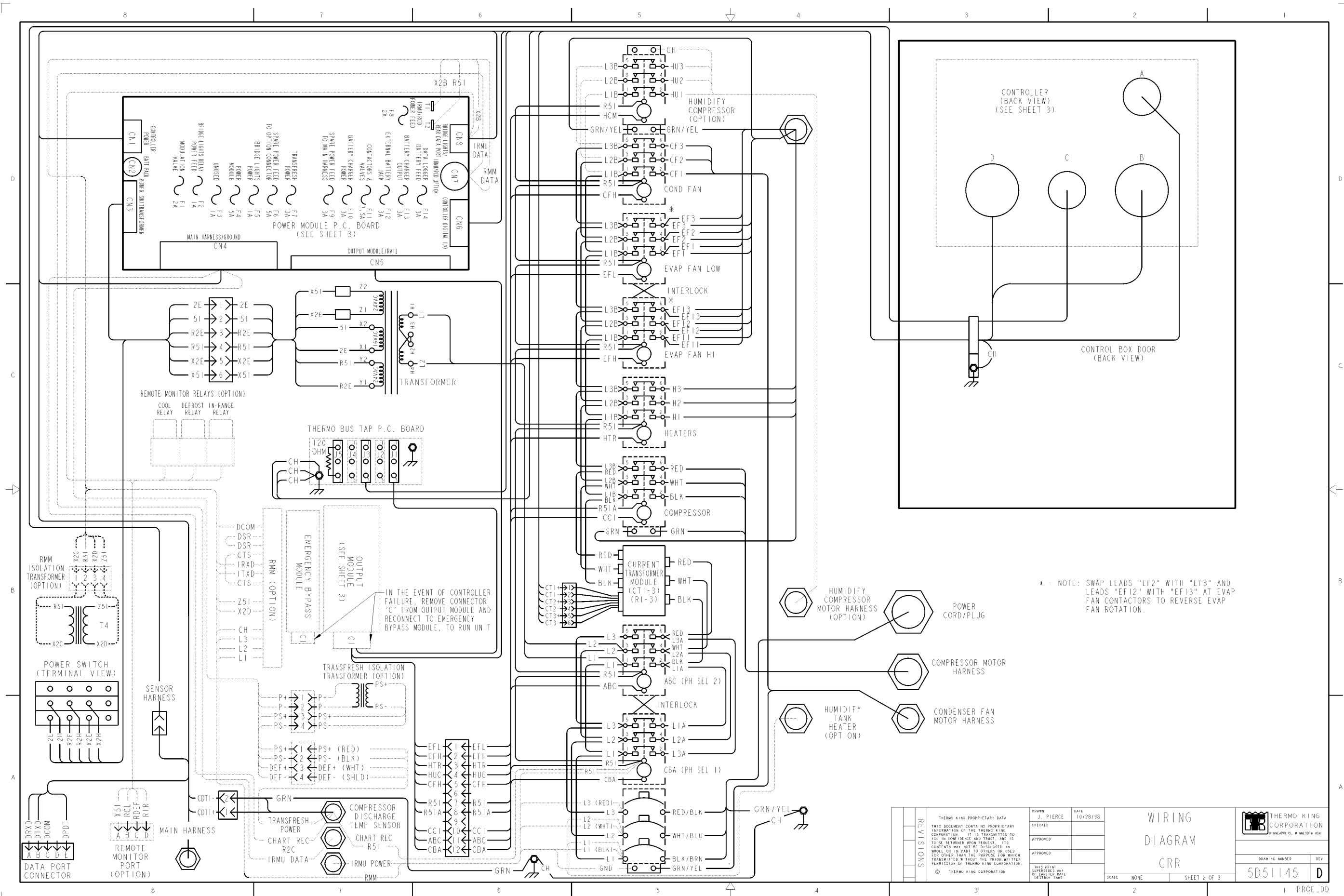

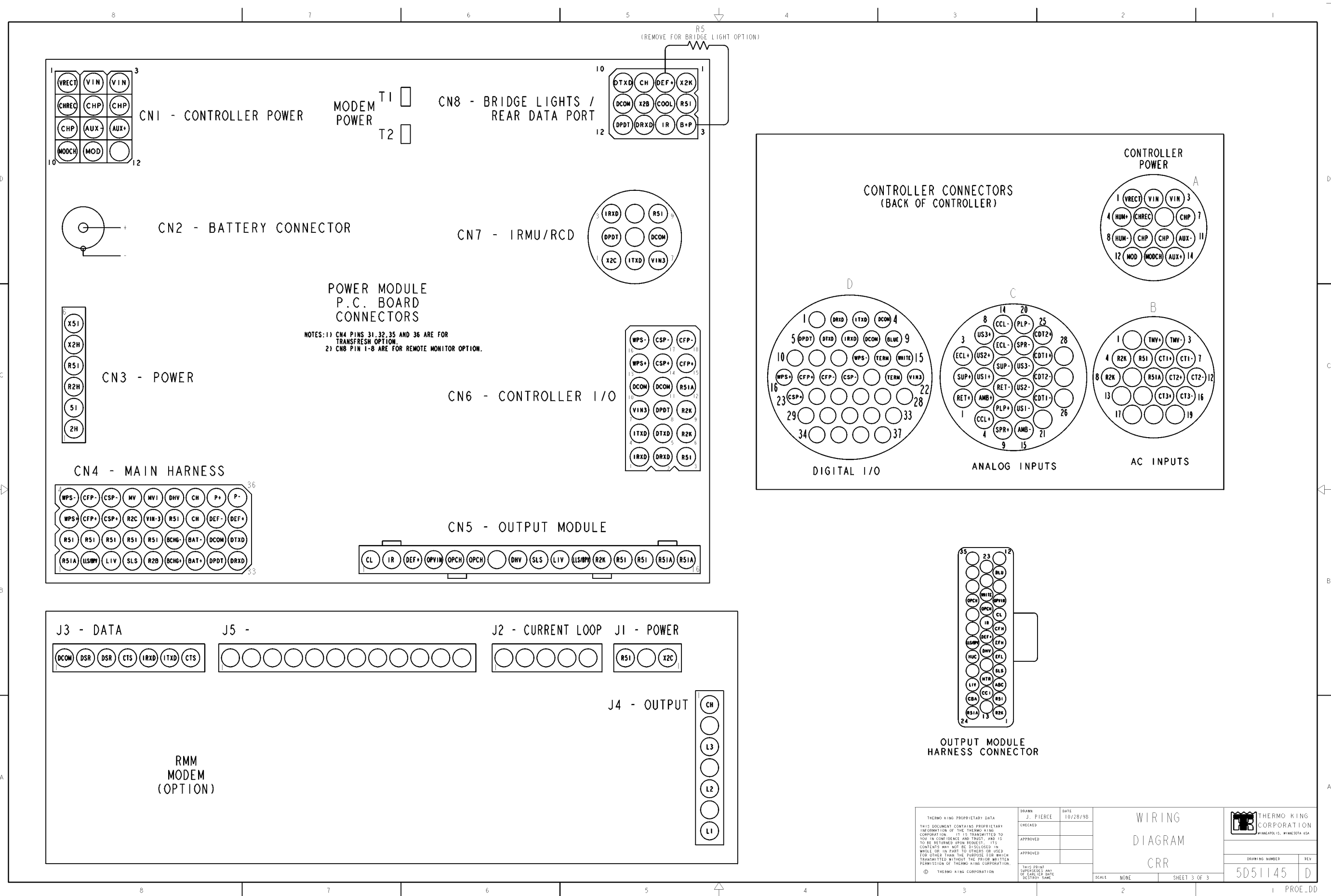

<small>THERMO KING PROPRIETARY DATA THIS DOCUMENT CONTAINS PROPRIETARY INFORMATION OF THE THERMO KING CORPORATION. IT IS TRANSMITTED TO YOU IN CONFIDENCE AND TRUST, AND IS TO BE RETURNED UPON REQUEST. ITS CONTENTS MAY NOT BE DISCLOSED IN WHOLE OR IN PART TO OTHERS OR USED FOR OTHER THAN THE PURPOSE FOR WHICH TRANSMITTED WITHOUT THE EXPRESS WRITTEN PERMISSION OF THERMO KING CORPORATION. © THERMO KING CORPORATION</small>	<small>DRAWN</small> J. PIERCE	<small>DATE</small> 10/28/98	WIRING DIAGRAM CRR	THERMO KING CORPORATION MINNEAPOLIS, MINNESOTA, USA	
	<small>CHECKED</small> 	<small>APPROVED</small> 			<small>DRAWING NUMBER</small> 5D51145
	<small>APPROVED</small> 	<small>SCALE</small> NONE			<small>REV</small> D
	<small>THIS PRINT SUPERSEDES ANY OF EARLIER DATE DESTROY SAME</small>	<small>SHEET</small> 3 OF 3			<small>PROJ.</small> DD

CRR-20 & CRR-40

Refrigeration System Components

1. 3DS Compressor
2. Oil Fill / Drain Fitting
3. Discharge Service Valve (DSV)
4. Condenser Fan Pressure Switch (CFPS)
5. High Pressure Cutout Switch (HPCO)
6. Compressor Head Discharge Temperature Sensor (CDTS)
7. Condenser Coil (Circular)
8. Receiver Tank
9. High Pressure Relief (Fusible Plug)
10. Receiver Tank Service Fitting
11. Sight Glass
12. Condenser Coil Subcooler Circuit
13. Liquid Line Service Valve
14. In-line Filter*
15. Dehydrator (Filter Drier)*
16. Heat Exchanger
17. Liquid Line Solenoid (LLS)
18. Expansion Valve (TXV)
19. Expansion Valve Feeler Bulb
20. Equalizer Line
21. Distributor
22. Evaporator Coil
23. Electric Heaters
24. Return Air Sensor (RET)
25. Evaporator Coil Sensor (ECOIL)
26. Supply Air Sensor (SUP)
27. Condenser Coil Sensor (CCOIL)
28. Ambient Sensor (AMBT)
29. Controller (µP-D)
30. Evaporator Pressure Regulator (KVQ Valve)
31. Suction Service Valve (SSV)
32. Liquid Injection Valve (LIV)
33. Condenser Check Valve (CCV)
34. Dehumidify Solenoid Valve (DSV) (Option)
35. Humidity Sensor (rH) (Option)
36. Water-Cooled Condenser-Receiver Tank** (Option)
37. Water Pressure Switch (WPS) (Option)
38. Water Inlet Coupling (Option)
39. Water Outlet Coupling (Option)
40. High Pressure Relief Valve (Option)

*Units built after 3/9/99 and all models with two evaporator fans feature a large, one-piece Filter Drier/In-line Filter.

**Units built after 8/99 feature a fusible plug and service fitting located on the tank.

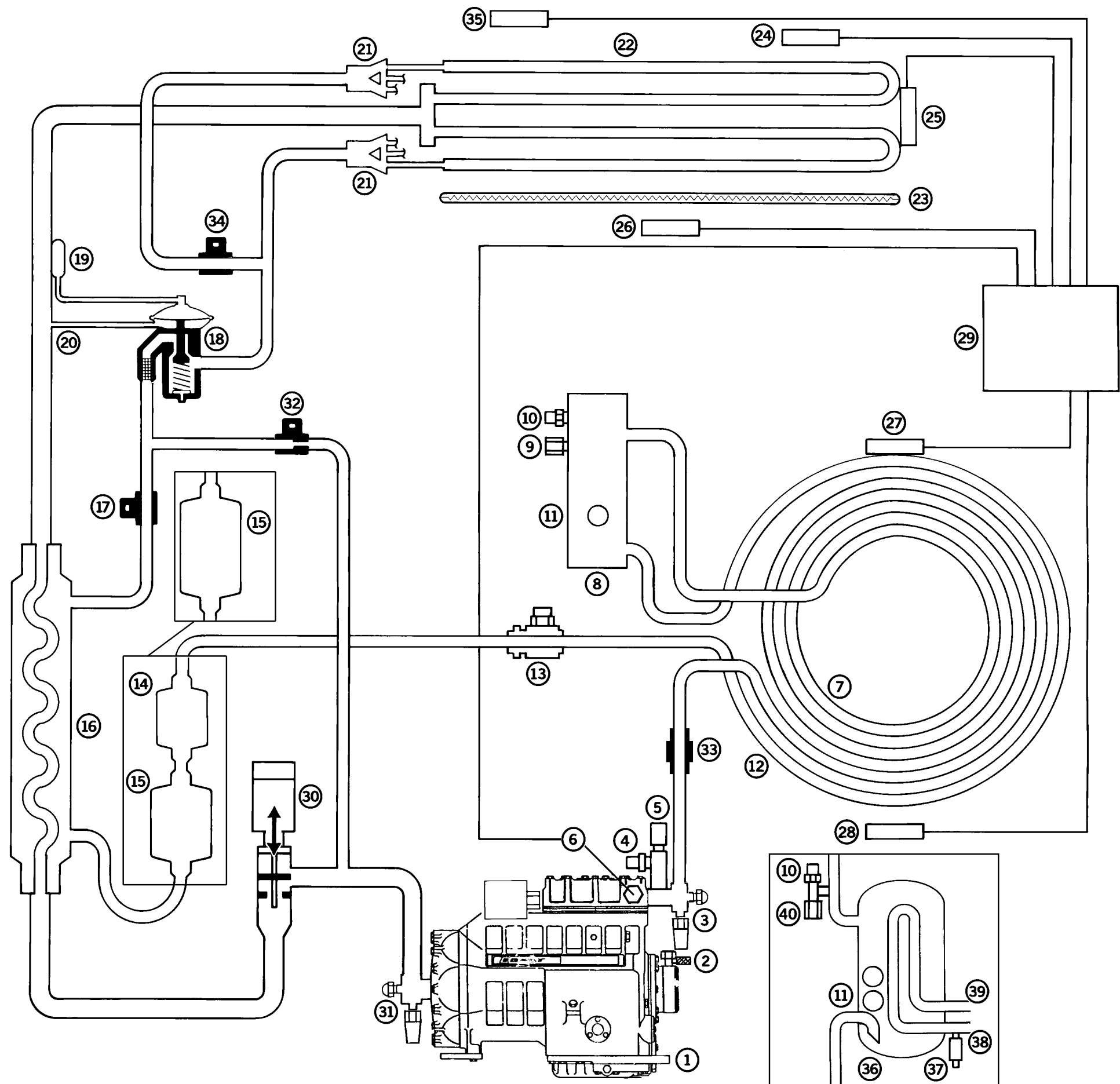

Flow and Pressure Diagram

CRR-20 & CRR-40

Full Cool

1. **3DS Compressor**
Compressor operation has a variable delay on initial start-up when the unit shifts to a cooling mode requiring the compressor to start.
 4. **Condenser Fan Pressure Switch (CFPS)**
Is a normally CLOSED switch.
It OPENS at 1380 +/- 50 kPa, 13.8 +/- 0.5 bar, 200 +/- 7 psig.
It CLOSSES at 1100 +/- 50 kPa, 11.0 +/- 0.5 bar, 160 +/- 7 psig.
 5. **High Pressure Cutout Switch (HPCO)**
Is a normally CLOSED switch.
It OPENS* at 2410 +/- 70 kPa, 24.1 +/- 0.7 bar, 350 +/- 10 psig.
It CLOSSES** at 1655 +/- 70 kPa, 16.5 +/- 0.7 bar, 240 +/- 10 psig.
*CRR-20-63: 2240 +/- 70 kPa, 22.4 +/- 0.7 bar, 325 +/- 10 psig.
**CRR-20-63: at 1590 +/- 70 kPa, 15.9 +/- 0.7 bar, 230 +/- 10 psig.
 9. **High Pressure Relief (Fusible Plug)**
BLOWS at 100 C (212 F).
 29. **Controller (µP-D)**
Thermoguard (µP-D) with digital thermostat, thermometer and fault indicator monitor.
- Null Mode Operation**
During the Null mode, the compressor does not operate. If the condenser fan is ON (based on condensing pressure) when the unit shifts to Null, the condenser fan operates for 30 seconds and stops. Evaporator fans continue to operate (evaporator fan speed is determined by return air temperature and economy mode setting).
37. **Water Pressure Switch (WPS) (Option)**
Is a normally CLOSED switch.
It OPENS at 117 +/- 21 kPa, 1.17 +/- 0.21 bar, 17 +/- 3 psig.
It CLOSSES at 35 +/- 21 kPa, 0.35 +/- 0.21 bar, 5 +/- 3 psig.
 40. **High Pressure Relief Valve (Before 8/99)**
OPENS at 3450 +345/-105 kPa, 34.5 +3.5/-1.0 bar, 500 +50/-15 psig.
CLOSSES at 2760 kPa, 27.6 bar, 400 psig.
- Fusible Plug on Tank (After 8/99)**
BLOWS at 100 C (212 F).

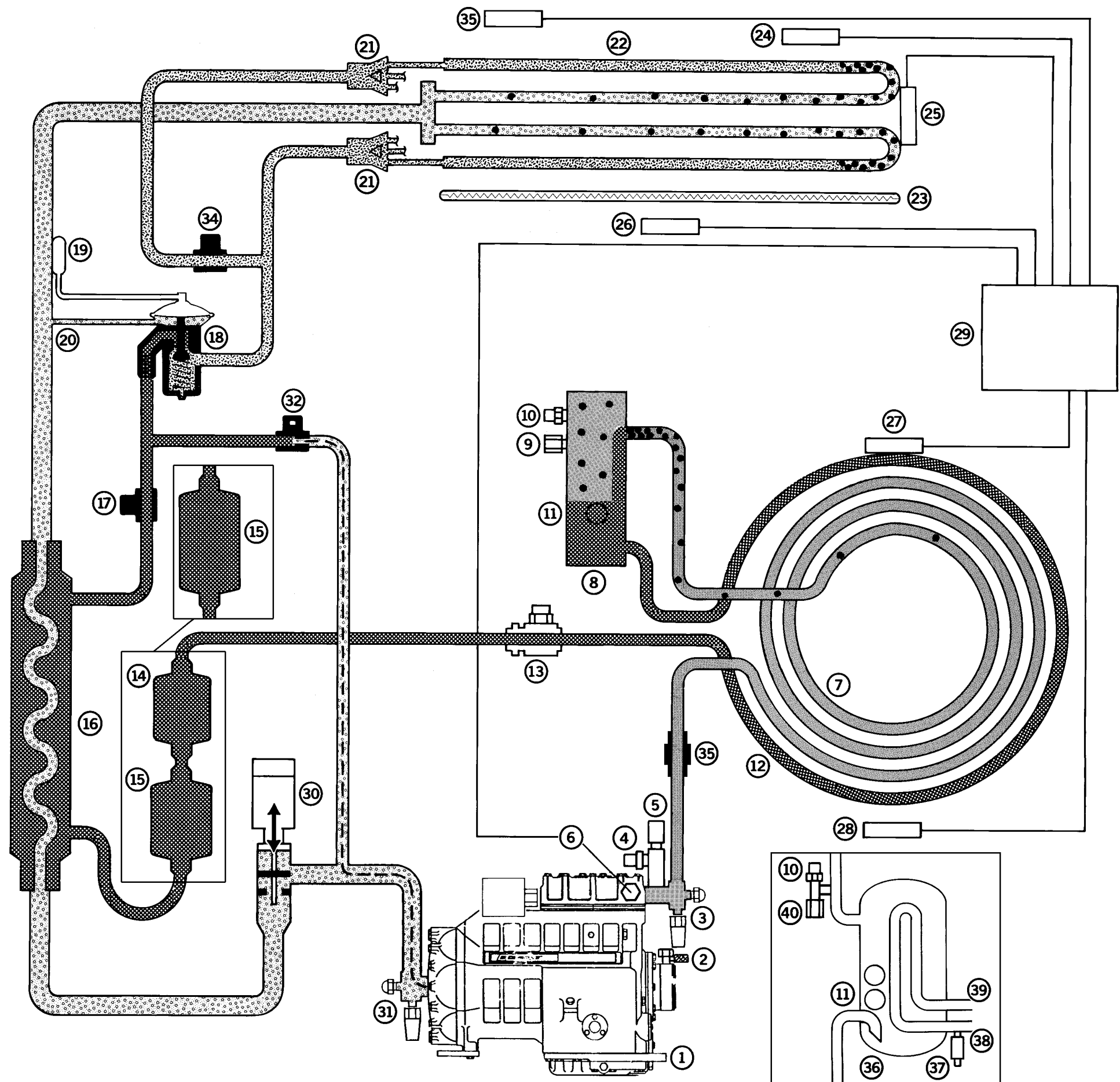
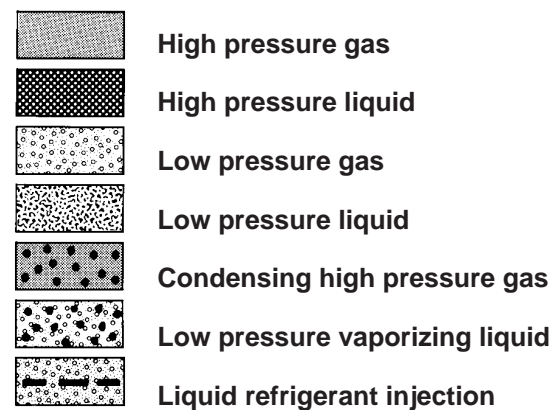

Flow and Pressure Diagram

CRR-20 & CRR-40

Modulation Cool

- 17. Liquid Line Solenoid (LLS)**
Is a normally CLOSED solenoid.
It OPENS when energized, when the compressor operates.
- 23. Electric Heaters**
During the DEFROST mode, the electric heaters are pulsed ON and OFF. The compressor does not operate. The condenser fan and evaporator fans remain OFF.
During the HEAT mode, the electric heaters are pulsed ON and OFF. The compressor does not operate. The condenser fan is OFF. The evaporator fans continue to operate (evaporator fan speed is determined by return air temperature and economy mode setting).
- 30. Evaporator Pressure Regulator (KVQ Valve)**
Is a normally OPEN actuator valve. It CLOSES (or OPENS) according to the strength and frequency of a pulsing voltage signal from the controller. The voltage signal energizes a heating element in the actuator power element. Increasing the temperature of the heating element increases the pressure on the main valve actuator, forcing the valve towards the closed position. Decreasing the temperature of the heating element decreases the pressure on the main valve actuator, drawing the valve towards the open position.
- 32. Liquid Injection Valve (LIV)**
Is a normally CLOSED valve.
It OPENS when energized. When liquid injection is required, the valve is pulsed open and closed on a 10 second cycle.
Liquid injection is controlled by the compressor discharge temperature.

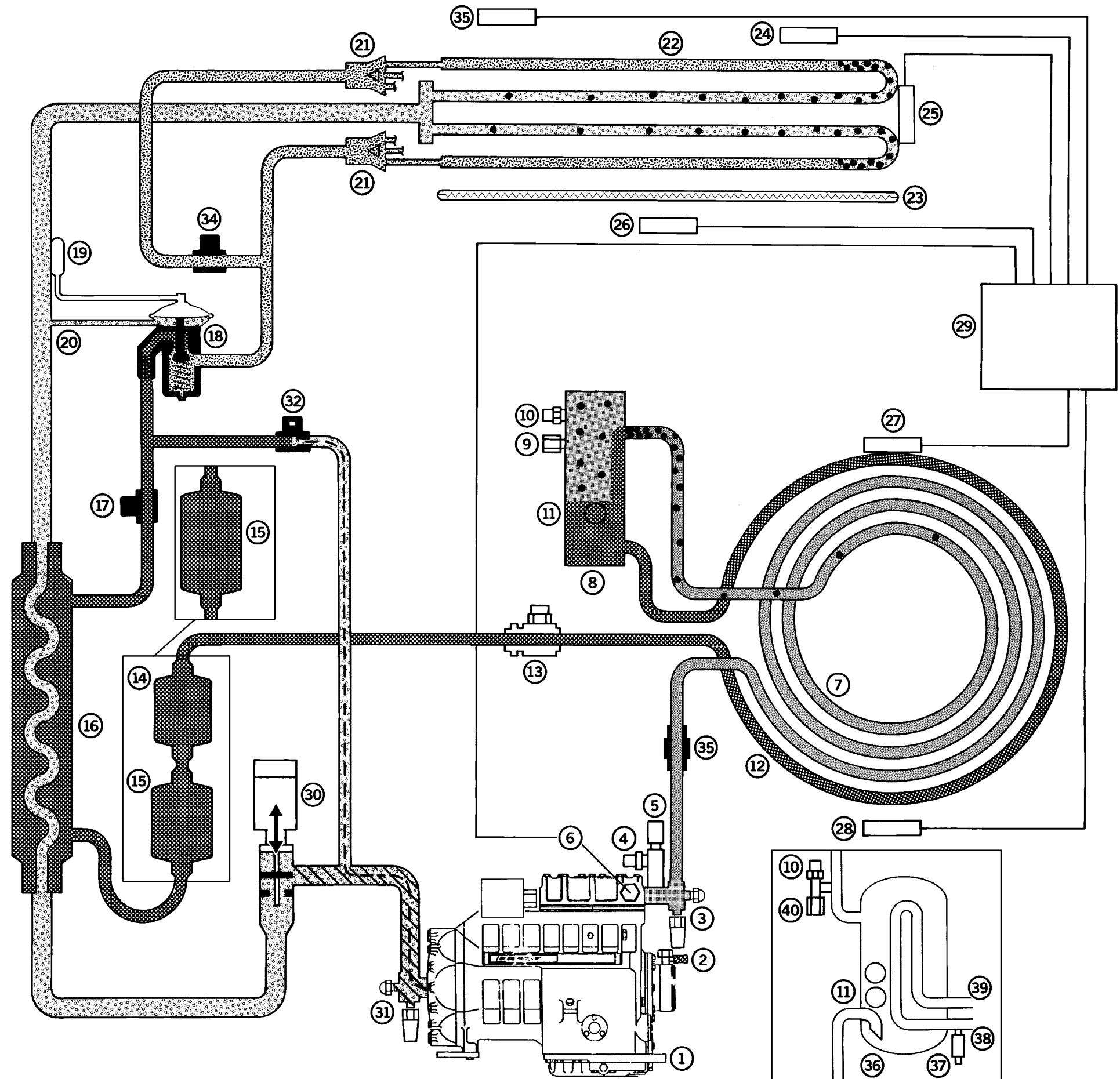
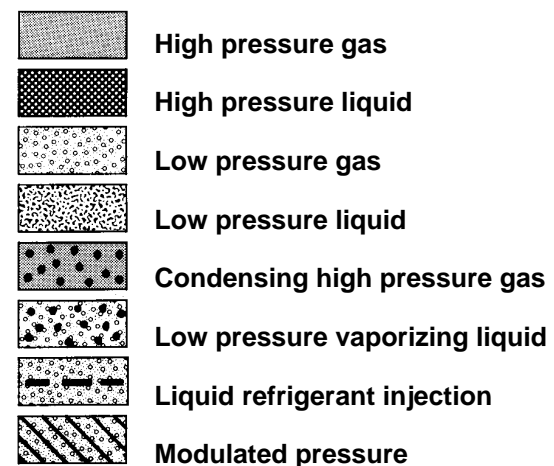

Flow and Pressure Diagram

CRR-20 & CRR-40

Dehumidification

23. Electric Heaters

If the container humidity is 5% or more above the humidity setpoint, and the temperature is in-range, the controller will pulse the electric heaters ON and OFF in addition to energizing (closing) the dehumidify solenoid valve. This increases the cooling load on the evaporator coil, thereby lowering the temperature of the entire coil and condensing more moisture from the container air.

34. Dehumidify Solenoid Valve (DSV) (Option)

Is a normally OPEN valve.

If the container humidity is between 1 and 5% above the humidity setpoint and the temperature is in-range, the controller will energize (CLOSE) the normally open solenoid. This closes refrigerant distribution to 50% of the evaporator coil, thereby lowering the temperature of the active part of the coil and condensing more moisture from the container air.

35. Humidity Sensor (rH) (Option)

The humidity sensor is located at the top right hand side of the evaporator fan deck and measures the humidity of the return air from the cargo space.

