

Operating and service manual

Star Cool refrigeration unit Model SCU-40 and SCI-40

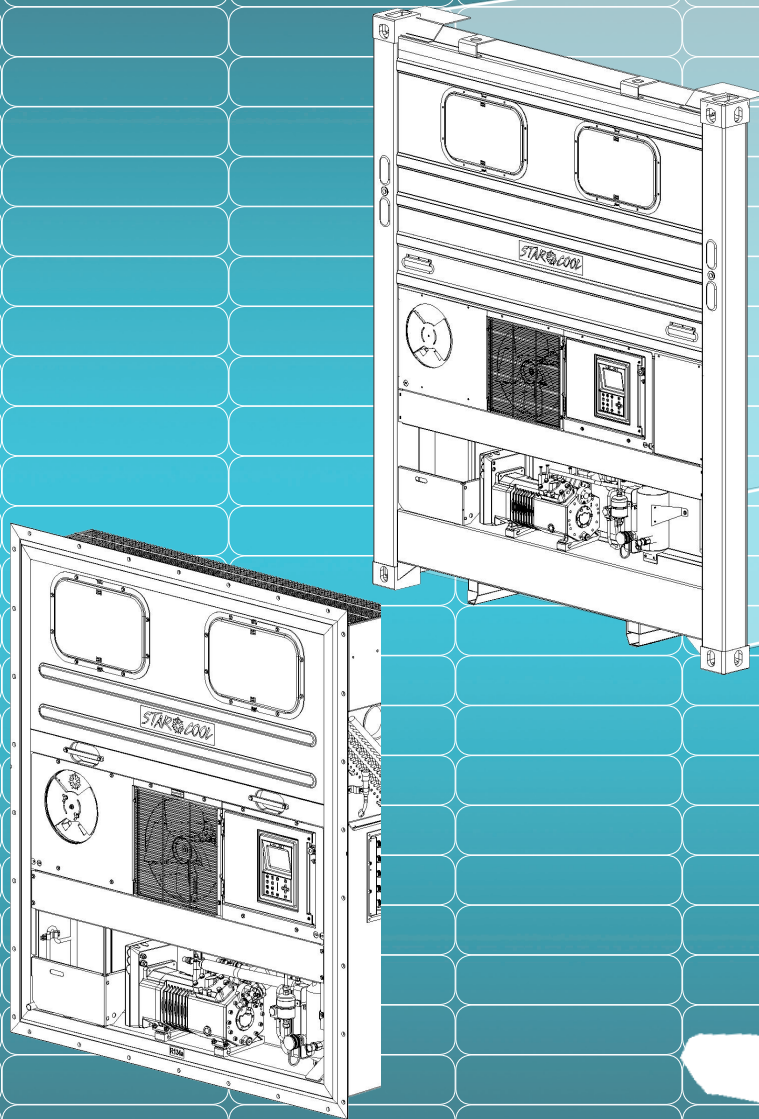



Preface

This version of the manual is dated December 2013, edited by Maersk Container Industry AS. All rights reserved.

This user's manual is valid for software version 0351 or newer versions.

The information herein is subject to change without notice and does not represent a commitment on any part of Maersk Container Industry AS.

While the information herein is assumed to be accurate, Maersk Container Industry AS assumes no responsibility for any errors or omissions that may appear in this documentation.

This manual is valid for:

Model	SCI - 40 and SCU - 40
Release Date	01.12.2013
Part number	810200B and 810300B.

Warnings

Do not operate or maintain this refrigeration unit until you have familiarized yourself completely with the equipment and operating of this unit by reading the instruction in this manual.

Do not perform any welding on the unit before disconnecting the power plug. Furthermore, disconnect the power meas module and main controller (and modem if present).

Disconnect main power supply to unit before inspecting the interior of the controller box.

The unit is charged with R134a and ester oil BSE 55. Do not use any other refrigerant or oil.

Do not use contaminated refrigerant or oil.

Do not release R134a into the atmosphere. Use recovery equipment according to present legislation.

During maintenance please observe that R134a is operating with high and low temperatures in combination with high pressures, which may cause personal injuries if not handled properly.

During recovery and maintenance of R134a unit personal protection equipment has to be worn.









Do not trap any liquid refrigerant inside pipes during soldering work. This may lead to explosion of pipe.



Contents

Preface	1
Warnings	1
Legend	6
General description	8
Function description	9
Start-up procedure.....	9
Climate Control Function	10
Temperature Control	10
Capacity Control and Limiter	10
Expansion Valve.....	11
Economizer Valve	12
Dehumidification	12
Condenser Fan.....	13
Evaporator Fan	13
Defrost Function	13
QUEST (optional).....	15
Frozen economy.....	15
Tests	15
Function test	16
Full PTI	17
Short PTI	17
Data Log	17
Alarm Action System (AAS)	19
Temperature control	19
Expansion valve control	19
Condenser fan control.....	20
Dehumidification control	20
Defrost control.....	20
Electrical control	20
Refrigeration system data	21
Refrigerant charge, R134a.....	21
General specification	22
Compressor – motor assembly.....	22
Frequency converter (FC).....	22
High Pressure cut – out switch.....	22
Fusible plug, receiver.....	22
Economizer.....	22
Evaporator coil.....	22
Condenser coil	23
Evaporator fan	23
Condenser fan	23
Water cooled condenser (optional)	23
Defrosting	23
Fresh air exchange	24
Refrigeration controls	24
Electrical data.....	24
Circuit Breaker.....	24
Contactors	24
Fuses.....	24
Power plug	24
Power Cable	24



USDA socket requirements	25
Evaporator fan motor	25
Condenser fan motor	25
Evaporator coil heaters	26
Temperature sensors, including USDA	26
Pressure transmitters	26
Miscellaneous	26
User Interface	26
Indicator lights	26
Display	27
Key pad	28
Menu overview	29
General Page layout	29
Changing a parameter value	30
Activating a function	30
Air exchange page	30
Operation	31
Menu Structure	31
General Operation	32
Temperature Setting	32
Wake-up Mode 	32
Contrast adjustment of the display	32
PTI or Function Test execution 	33
Info Menu Viewing	36
Operation Parameter Setting 	40
Programs:	40
Multiple Temperature Set points program, MTS	41
Cold Treatment program, CT	42
Alarms	43
Service Function Setting/Viewing 	44
Manual operations:	45
Datalog view:	46
Time adjust:	47
Run time counters:	47
Configuration:	48
Serial Numbers	49
°C and °F Temperature Scale Showing, Alternately 	50
Viewing graph of Supply and Return Temperature 	50
Manual Defrost Initiation 	50
Water-cooling Activation/Deactivation 	51
Emergency Operation	51
FC defective	51
Controller defective	52
External interfaces	52
General requirements	52
List of terms used for external interfaces	53
Functions overview	53
Location of valves	54
Location of motors, temperature sensors, humidity sensor and air exchange potentiometer	55
Location of pressure transmitters, high pressure switch and oil outlet port	56



General trouble shooting	56
Trouble shooting for Star Cool main controller	57
Detailed alarm description	57
Alarm list	58
Events	62
Temperature Sensor Alarms (AL 1XX)	65
Pressure transmitter Alarms (AL 2XX)	86
Other Sensor Alarms (AL 3XX)	91
Power Alarms (AL 4XX)	98
Frequency Converter (FC) Alarms (AL 5XX)	110
Operation Alarms (AL 6XX)	126
Communication Alarms (AL 7XX)	143
Test Alarms (AL 8XX)	148
Controller Alarms (AL 9XX)	162
Calibration of air exchange sensor	188
Sensor calibration using StarView	188
Replacing of unit	189
Replacement Evaporator motor and fan	190
Replacement Condenser motor and fan	190
Replacement of evaporator	191
Replacement of FC	193
Replacement of compressor	194
Replacement of compressor valve plate / cylinder head gasket	195
Service and maintenance	196
Evacuation of refrigerant	196
Compressor pump down, operation	196
Compressor pump down, replaced	197
Pump down of unit	198
Pressure Test	198
Charging of refrigerant	199
Charging of an empty unit	199
Charging of unit low on charge	199
Leakage detection	200
Fan motors (in not using plug)	200
Drying filter	201
Replacing of drying filter	201
Compressor	201
Check of oil level	201
Charging of oil	202
Draining of oil from compressor	202
Soldering	203
Welding	203
Tables	203
Datalog description	203
Temperature Sensor [°C] - Resistance Table	205
Temperature Sensor [°F] - Resistance Table	206



Air exchange Sensor table Voltage - m3/h for 35 CMH	207
Air exchange Sensor table Voltage - m3/h for 75 CMH	207
Voltage – Pressure Table, Low pressure transmitter (AKS)	208
Voltage – Pressure Table, Low pressure transmitter (NSK)	209
Voltage – Pressure Table, High pressure transmitter (AKS)	210
Voltage – Pressure Table, High pressure transmitter (NSK)	211
Temperature Sensor - Voltage Table	212
Pressure/Temperature table for R134a	213
Tightening torques	214
Controller Unit Illustration	215
Star Cool Unit, installation dimensions	217
P & I diagram	219
Overall Wiring Schematic.....	220
Overall wiring schematics (optional)	222



Legend

Short name	Name		
AirEx	Air Exchange	Pdis	Discharge Pressure
AirEx mo	Air exchange motor	Pfc	Power used by Frequency Converter
Alarm	Alarm	PhDir	Phase Direction
AKS	Danfoss pressure transmitter	Psuc	Suction Pressure
Bat	Battery	Ptot	Power Total
CalAex	Calibration value AirEx	PTI	Pre Trip Inspection
CalUs1	Calibration USDA sensor 1	PTI Short	Pre Trip Inspection Short
CalUs2	Calibration USDA sensor 2	Pwr	Power
CalUs3	Calibration USDA sensor 3	RH	Relative Humidity
CalCar	Calibration Cargo sensor	RHset	Humidity Set point
CapAct	Actual capacity	RMM	Remote Monitoring Modem (power line communication)
CapReq	Requested capacity	SHTV	Superheat Thermo Valve
Com	Communication	Shp	High pressure switch
ComQ	Communication Quality FC	SHReq	Superheat Requested
Cpr	Compressor	T0	Calculated Evaporator Temperature
CT	Cold Treatment	Tact	Actual Temperature
FC	Frequency Converter	Tamb	Ambient Temperature
Fcpr	Compressor Frequency	TC	Calculated condenser Temperature
FcprAct	Compressor Frequency actual	Tcargo	Cargo Temperature
FcprReq	Compressor Frequency requested	Tdis	Discharge Temperature
Flower	Compressor Frequency min.	Tevap	Evaporator Temperature
Fpower	Power supply Frequency converter	Tfc	Frequency converter Temperature
Fref	Compressor Frequency requested	Tint	Tinternal (controller board)
Fupper	Compressor Frequency max.	Tret	Return Air Temperature
Gear	Gear	Tset	Temperature Setpoint
Gnd	Ground	Tsuc	Suction Temperature
Hevap	Evaporator Heater	Tsup	Supply Air Temperature
I1	Current Phase 1	Tsup1	Supply Air Temperature 1
I2	Current Phase 2	Tsup2	Supply Air Temperature 2
I3	Current Phase 3	Tusda1	USDA 1 Temperature
Idc	Current in DC Frequency Converter	Tusda2	USDA 2 Temperature
Ifc	Current in AC Compressor Motor	Tusda3	USDA 3 Temperature
IceMas	Theoretical Ice mass in Evaporator	U12	Voltage Phase 1-2
LED	Light Emitting Diode	U13	Voltage Phase 1-3
MaxInt	Max. internal temp. controller	U23	Voltage Phase 2-3
Mcpr	Compressor Motor	U/f	Voltage/frequency ratio
McOH	Condenser Motor Over Heat	Ubat	Battery voltage
Mcond	Condenser Motor	Udc	DC voltage in Frequency Converter
Mevap	Evaporator Motor	Umean	Mean Voltage = (U12+U13+U23)/3
Mevap1	Evaporator Motor 1	Umotor	Mean Voltage Compressor Motor
Mevap2	Evaporator Motor 2	Veco	Economizer Valve
Mevap1OH	Evaporator Motor 1 overheat	Vexp	Expansion Valve
Mevap2OH	Evaporator Motor 2 overheat	Vhg	Hot gas Valve
MTS	Multi Temperature Settings	Warn	Warning
NSK	SAGInoMIYA pressure transmitter		
OprMod	Operation Mode		
PCB	Printed Circuit Board		



Prefix	Description
F	Frequency
H	Heater
I	Current
M	Motor
P	Pressure
Q	Power
RH	Relative humidity
S	Switch / contact / key
SH	Super heat
T	Temperature
T0	Saturated suction temperature
U	Voltage
V	Valve

Contraction	Full name
Amb	Ambient
Bat	Battery
Cond	Condenser
Cpr	Compressor
Dis	Discharge
Eco	Economizer
Evap	Evaporator
Fc	Frequency converter
Motor	Compressor motor
Pwr	Power
Ret	Return
Suc	Suction
Sup	Supply

Suffix	Specification
Act	Actual
In	Input
OH	Overheat
Out	Output
Req	Requested
Set	Setpoint



General description

The STAR*COOL units, models SCU-40 and SCI-40 are electric powered picture frames, cooling and heating units operating on refrigerant R134a.

The unit is designed to maintain cargo temperatures in a range from -30°C (-22°F) to $+30^{\circ}\text{C}$ (86°F).

The unit is designed to operate in ambient temperatures from -30°C (-22°F) to $+50^{\circ}\text{C}$ (122°F).

The outer front frame is constructed of marine grade aluminium, 5000 and 6000 series, designed to serve adequately as the container end wall.

The rear bulkhead is made of food-approved material.

The unit is designed to operate with satisfaction under sea going and environmental conditions as specified below:

- Salt – laden air, sea spray and high humidity.
- Rolling: Amplitude of 30° each side, period of 13 seconds.
- Pitching: Amplitude of 6° each side, period of 8 seconds.
- Permanent list: 15° on each side.
- Shock: 2g horizontal and 5g vertical.
- Vibrations: Of the types encountered on ships, trucks and rail.

The unit consists of the following modules.

- Frame module
- Condenser / compressor module
- Evaporator module
- Evaporator fan module

The cooling system of the unit is equipped with a two – stage compressor, electrically driven through a FC.

The cooling system is also equipped with an economizer, which performs the task of sub-cooling the liquid from receiver to evaporator, thereby increasing the cooling capacity of the cooling unit. The evaporator and economizer are controlled by electronic expansion valves.

The equipment is designed to operate on a nominal 410/450 V AC, 3 phase, 50/60 Hz, primary power source, according to ISO 1496-2.

An integrated dual winding transformer supplies the control circuit voltage. One winding for 24 V AC (for RMM modem supply) and another for 26 V AC converted to DC-Voltage in the controller (for controller and contactor supply). The output voltage is dependent on supply voltage.

An automatic system, power supply sensing and correction, is provided to ensure the correct direction of rotation for the fan motors. This is done regardless of the incoming phase sequence from the primary power supply, provided that all fan motors are wired correctly.

An optional water-cooled condenser is mounted in series with the air-cooled condenser. This water-cooled condenser allows operation of unit below deck, where no air ventilation is possible, provided that water connections are present.

The unit is controlled by an electronic controller manufactured by Lodam Electronics, controlling the supply temperature probe in chilled mode (temperature setting above or equal to -5°C (23°F)) and the return temperature in the frozen mode (temperature setting below -5°C (23°F)). Controller accuracy is $\pm 0.25^{\circ}\text{C}$ ($\pm 0.45^{\circ}\text{F}$).

The unit can operate the evaporator fans in low speed and high speed. From the controller display, Normal or Economy mode can be selected under operation menu.

In economy mode the fans always run on low speed. In normal mode the fan speed can run in high or low speed depending on running conditions.

The air from the unit is delivered to the bottom of the container, with return air through the top of the evaporator coil section (bottom air delivery).

The unit is equipped with a de-humidification function controlled by the electronic controller of



the unit. The humidity setpoint can be set in the range from 95 – 65% (or 50 % with closed ventilation) RH. The unit can control to the lowest level. The de-humidification function is active as long as the temperature control is in set point range. The unit is equipped with heating elements, mounted under the evaporator coil, for the de-humidification. The de-humidification system is also active in economy mode.

The unit is equipped with a dual system for defrosting. There is installed a hot gas valve, in the refrigeration system, for hot gas defrosting of the evaporator coil. Furthermore the heating elements, mounted under the evaporator coil, are energized during defrost. This dual system for defrosting ensures a fast defrost sequence and thereby only a very small input of heat to the container. This results in very small temperature variations for the transported cargo, after a defrost sequence. The dual system for defrost also ensures an even distribution of heat to the evaporator coil. The result of this is that there is no building up of ice in corners or other places of the evaporator coil. The two defrost systems, hot gas and heating elements, are independent. This ensures a defrost sequence to be carried out, even with one system failing. A demand defrost system is integrated in the software ensuring that the evaporator coil will not ice up.

The unit is equipped with a datalogger incorporated in the controller.

The logging interval is in predefined intervals, 15, 30, 60, 120 or 240 minutes. The logging of the USDA – sensors (3 pieces) and Cargo - sensor is done with an interval of one hour according to USDA requirements. With a logging interval of one hour, there is storage capacity for 365 days of temperature loggings. Datalogger accuracy is $\pm 0.25^{\circ}\text{C}$ ($\pm 0.45^{\circ}\text{F}$). The data – log can be retrieved with a PC – system Starview and Psion Logman, via high-speed serial communication port. The controller has a battery back – up system for the datalogger, which after power switch off of the unit continues logging in battery mode 120 times and then stops. The controller is prepared for communication with Remote Monitoring Modem (RMM), according to ISO standard 10368, for monitoring at the ship bridge or control room. Events + Alarms and Short Log can be retrieved by Refcon, Logman, StarView and can be viewed by Refcon, LogView and StarView. Extended Log can only be retrieved by Logman and StarView and shown in LogView and StarView.

Function description

Start-up procedure

The start-up procedure ensures that the system is started safely after the following events:

- Unit has been out of use
- Main failures
- Defrosting
- PTI test
- Service mode
- Alarm mode

The start-up procedure has 5 modes:

1. Initialize: Self check controller.
2. Stabilize: The evaporator fan operates at high speed to ensure that temperature sensors are at current temperature.
3. Crank case heating: If Tamb is lower than 2°C (36°F) heat is applied until Tfc is above 12°C (54°F).
4. Ramp up
5. Terminate: Switching to normal temperature and valve regulation.



Climate Control Function

Temperature Control

This function incorporates the container temperature controller.

The function has 2 modes: Chill and Frozen.

- Chill
If Tset more than ($>$) -5°C (23°F) the chill mode is activated.
If Standard Tact = Tsup if cooling need, and Tact = Tret if heating is needed.
If QUEST is activated, see QUEST
- Frozen
If Tset is less than or equal to (\leq) -5°C (23°F) the frozen mode is activated and Tact = Tret.
The value the Tset limit is dependent on software version.

This function has four modes: Pull down, Pull up, Cool, and Heat.

Pull Down / Pull Up mode:

In Pull Up and Pull Down mode no in-range alarm is given.

Upon start-up, defrost or another mode deactivating temperature control (e.g. manual, set-point alternation, PTI) the temperature control is set to Pull Down or Pull Up mode depending on Tact being above or below Tset.

As long as temperature is not within Tset +/- ranges, the function remains in CoolPullDown or HeatPullUp mode. If temperature is within range, the green "IN-RANGE" indicator light starts flashing. When the temperature has been within Tset +/- ranges for 30 min. the green "IN-RANGE" indicator light is constant on.

Cool / Heat mode:

Temperature is within Tset +/- ranges and the green "IN-RANGE" indicator light is constant on. If temperature is in out-of-range condition for more than 2 hours, the IN-RANGE indicator lights start flashing. After 4 hours out-of-range condition, an in-range alarm is set.

On the basis of Tact and Tset the function calculates the requested capacity (CapReq) value by means of a PID controller. CapReq is the desired chilling / heating capacity. CapReq value can range from -100% to $+100\%$. -100% being maximum cooling and $+100\%$ being maximum heating.

Capacity Control and Limiter

On the basis of requested capacity this function determines operation mode and actions of the individual system components (compressor, valves, heating elements) and ensures that compressor minimum off time is observed.

This function has 5 gears (modes). On the basis of requested capacity, the gear is determined. Compressor frequency is directly dependent upon current mode. Evaporator heater, on the other hand, is gear independent.

There is overlap over the modes to maintain slow mode shifting.

Gear	Function
Off	Everything is turned off.
Start up	If cooling is required, the FC is starting at default frequency before shifting to correct cooling mode.
PWM	On/Off regulation of compressor.
CoolEco	Maximum cooling capacity with use of economizer.
Heat	Only the heaters are used.
Defrost	Heaters are always used and hot gas valve is used if ambient temperature is above 5°C (41°F).

The capacity of the unit is controlled between maximum cooling capacity (-100% capacity) and maximum heating capacity ($+100\%$ capacity). This is done by regulation of the compressor speed



by means of the FC or on/off regulation. In maximum capacity (+100% capacity) the unit uses the heating elements, by means of pulse width modulation, to control the capacity. Below figure indicates the ranges for the capacity and compressor speed (frequency).

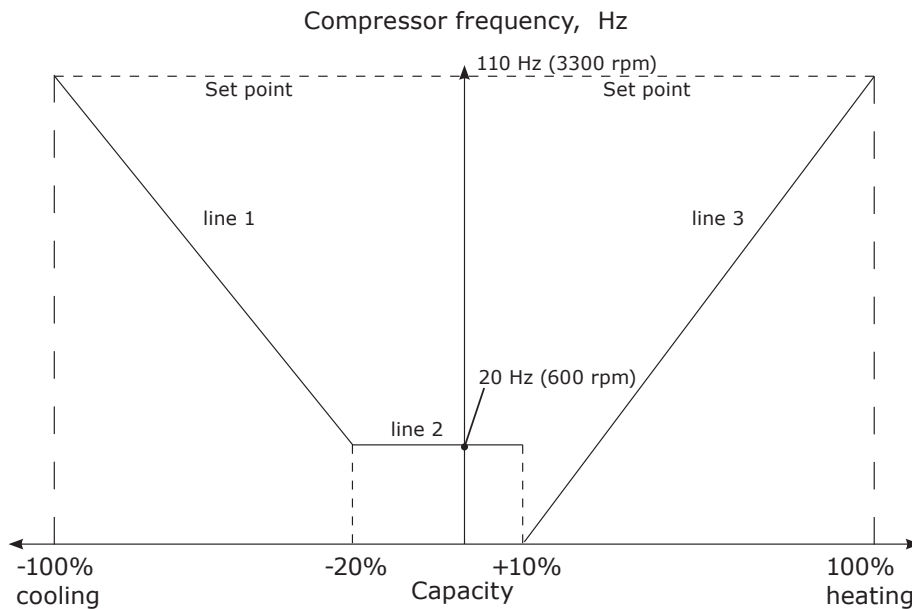

Line 1: The area where cooling is requested, controlled by the frequency converter.

Line 2: The area where the compressor is on/off regulated.

Line 3: The area where heating is requested, controlled by pulsing of heating elements.

The limiter function secures that the controller operates with valid settings to protect the unit in order to maintain the conditions for the cargo. To maintain the set point temperature, capacity control constantly monitors and adjusts the capacity. The limiter acts as a brake to the capacity change requests from capacity control and thereby controlling how fast the capacity can change, so that safe operation of the unit constantly is ensured.

The limiter monitors the following parameters from the unit and generates a limiter factor for each:

- IFC, to limit the maximum current draw from the FC.
- TFC, to limit the maximum internal FC temperature.
- Tc, to limit the maximum condenser pressure (and temperature).
- T0, to ensure a minimum evaporator pressure.

The largest of the factors is used as the active limiter. If the limiter factor is higher than the requested capacity change, the capacity is actually reduced instead of increased.

If for example the ambient temperature is very high, the requested capacity may increase the FC temperature over its limits and so the limiter will reduce the capacity until a safe and stable operation condition for the FC has been reached.

Expansion Valve

This function ensures optimum evaporator superheat (SH) and calculates the percentage of opening (SHVod) and controls the valve. This function is active during compressor operation. Valve is closed during compressor turn off.

Expansion valve function includes the following sub-functions:

- MSS (Minimum Stable Superheat search).
- Superheat control.
- MOP (Maximum Operating Pressure).

MSS

This function searches for minimum stable superheat within the ranges SHmin and SHmax. With a stable T0, SHset is reduced and with an unstable T0, SHset is raised.



SHact: = $T_{suc} - T_0$

Superheating

Function output is the expansion valve opening rate (V_{exp}).

At start-up the opening rate is 0%.

The electronic expansion valve is an on/off valve controlled on the basis of opening rate with a constant cycle time.

MOP function

The MOP function prevents the suction pressure from getting too high.

Economizer Valve

This function ensures optimum sub cooling of liquid to the evaporator and cooling of the FC.

In addition, the cooling capacity is increased, COP is enhanced and compressed gas temperature is reduced.

Function output is the economizer valve opening rate (V_{eco}).

The economizer control has two modes:

- Superheat control
- FC cooler.

Superheat control

Valve opening rate control is based on calculations.

FC cooler

This function is active during compressor operation.

Dehumidification

The dehumidification function dehumidifies air in the container by means of a heater.

This function is can only be activated if the temperature control function is active.

Dehumidification is achieved by decreasing evaporator surface temperature.

This is done through activation of the heater and letting the temperature control increase cooling capacity resulting in an evaporator temperature descending.

This function has 3 modes:

- Off
- Active
- Override

Dehumidification: Off

The dehumidification function is in the OFF position.

Dehumidification: Active

The heater (H_{evap}) is activated when RH is more than ($>$) RHSet and deactivated when RH is less than ($<$) RHSet - 3 [%]

The humidity set point can be set in the range 50% to 95% relative humidity. The range 50% to 64% is only possible with no fresh air - evap. ventilation in low speed. The range 65% - 95% is possible to run with fresh air - evap. ventilation in high speed.



Dehumidification: Override

Accessing override mode if:

- Cooling demand exceeds 80% capacity.
- Large demand for heating.
- PTI
- A fatal alarm is active.
- When operating without FC.
- Manual operation is active.
- Defrosting

Other comments



The dehumidification icon  is shown in the display even if override is active.
The heat icon  follows the current state of the heater.

Condenser Fan

Condenser fan control will reduce condenser pressure through condenser ventilation.
The condenser pressure control also monitors the compressor outlet pressure in case of water-cooling.

This function is activated when control is being in the automatic mode.

Condenser pressure control has two primary modes:

Air-cooled
Water-cooled

Air-cooled

In the air-cooled mode ventilation takes place in the following way:

Depending on the compressor outlet pressure, the fan is Off or runs in 2 different speeds: High and Low.

The fan runs in 4 modes: Off, low-speed, high-speed and a cycle shifting between high and low-speed in two minutes intervals.

If Tamb is more than (>) 48°C (118°F) or the compressor outlet pressure remains constantly high, the condenser fan constantly runs at high speed.

Water-cooled

If the condenser fan is constantly on for more than 1 hour, an alarm will be given.

The fan runs in 4 modes: Off, low-speed, high-speed and a cycles shifting between high and low-speed in two minutes intervals.

Evaporator Fan

The evaporator fan function ensures correct fan speed (high or low).
The function is active in the automatic mode.

This function has 2 modes:

Normal
Economy

Normal

Low speed in the frozen mode or if the following three conditions are set

- Tset is more than or equal to (>) 0°C (32°F)
- No fresh air exchange
- Dehumidification is turned off or humidity set point below 65%

Otherwise high speed

Economy

The fans run at a constant low speed. Exception: Tret > Tsup + 8°C (14°F) then high speed, until Tret > Tsup + 3°C (5°F) is reached

Economy mode is switched on by the operator.

Defrost Function

Defrost function ensures regular evaporator defrosting. The function is active in automatic mode.

The defrost function has 4 modes:

Wait
Initialize
Execute
Terminate



Wait

In the wait mode the time is refreshed for the next defrost provided that the following conditions are satisfied:

- Compressor is running
- T0 is less than (<) T0min.

Wait mode termination can be due to:

- Calculated ice amount in the evaporator is above critical level (Demand defrost)
- Defrosting action initiated manually (Manual defrost initiation)

Initialize

Wait until condenser temperature is above 50°C (122°F), however no more than 300 sec.

Execute

In this mode the actual evaporator defrosting takes place:

A Defrost start event is made in the trip log.

Cooling system termination results in compressor initiation, only ramp up mode is executed.

Evaporator fan is stopped.

Evaporator heating elements are turned on.

Compressor runs at a constant frequency at 83% of full speed.

Expansion valve control is deactivated.

Hot gas valve is used to heat the evaporator from the inside with the hot gas from the compressor.

Evaporator defrosting terminates when evaporator temperature, T_{evap}, is above defrost termination temperature for 2 min. or upon elapse of max. defrost time.

A defrost stop event is made in the data log with the current interval and T_{evap} temperature.

Terminate

Terminate mode is dividable into two parts:

- Evaporator re freezing preventing remaining water drops on evaporator from blowing into container upon evaporator fan initiation.
- Termination ensuring low evaporator fan speed to prevent shock boiling and to ensure that the temperature controller takes over in a controlled way.

After termination, the unit continues normal operation again with the same setpoint temperature as before defrost start.

General information

If the T_{evap} sensor is not OK, adaptive defrosting uses a reduced defrost interval compared to normal calculated defrost intervals.

Set-point alteration leads to a new calculated defrost interval, and defrost starts when the defrost criteria is reached.

With manual defrost initiation the current defrost interval is set to default defrost interval.

Manual defrost termination

Upon manual defrost termination, termination state is entered. No adaptive adjustment takes place when defrosting is manually initiated.

Regarding user interface

Defrost icon is displayed during defrost function execution.

Other comments

If service mode or PTI mode is selected during a defrost, the defrost mode is terminated and the time for the next defrosting is set to the preset value as if a normal defrost end had occurred.

If the unit is shut off for some reason during a defrost and the power disappears for less than (<) 12 hours, the unit will start and try to finish the defrost again when the power returns.

If the unit is shut off for more than 12 hours, the active defrost is terminated and the defrost function enters the wait state.



QUEST (optional)

QUEST is a program based on a fixed protocol designed to reduce the energy consumption of the unit, when operating in the interval -1°C to $+30^{\circ}\text{C}$ (30°F to 86°F). This energy saving is mainly obtained by regulating the compressors on/off time and the evaporator fan speed.

Please note that when T_{sup} is in the range -1°C to $+15^{\circ}\text{C}$ (30°F to 59°F) its value can vary -2°C - $+1^{\circ}\text{C}$ (28°F to 34°F) from setpoint.

Please note that when T_{sup} is in the range $+15^{\circ}\text{C}$ to $+30^{\circ}\text{C}$ (30°F to 86°F) its value can vary -4°C - $+1^{\circ}\text{C}$ (25°F to 34°F) from setpoint.

QUEST is, as default, set to either **AUTO** or **OFF** depending on customer requirements.

To deactivate QUEST:

1. Press
2. Use or to select O03 QUEST and press
3. Select "OFF" by using or and press

To activate QUEST:

1. Press
2. Use or to select O03 QUEST and press

If O03 is empty, QUEST is not installed.

Star Cool is responsible for that the QUEST function is operating within the parameters and the running pattern defined by the protocol. Star Cool is however not liable for any consequent damages caused by the QUEST functionality.

Frozen economy

Frozen economy can not be engaged if $T_{\text{set}} > -15^{\circ}\text{C}$ (5°F).

If $T_{\text{ret}} < T_{\text{set}} - 1^{\circ}\text{C}$ (1.8°F) both compressor and evaporator fans stops.

After 15 min evaporator fans starts and T_{ret} is measured.

If

- $T_{\text{ret}} < T_{\text{set}} + 2^{\circ}\text{C}$ (3.6°F) evaporator fans will stop again.
- $T_{\text{ret}} < T_{\text{set}} + 2^{\circ}\text{C}$ (3.6°F) is not reached within 5 min, both evaporator fans and compressor will run until $T_{\text{ret}} < T_{\text{set}} - 1^{\circ}\text{C}$ (1.8°F) is reached. At that point evaporator fans and compressor will stop again.

Evaporator fans are running on LOW speed when activated.

Tests

The unit has 2 (3) test functions:

- Function test.
- PTI (Pre-Trip Inspection) test.
- PTI short (optional)

The PTI test is a function test followed by a capacity test where the requested temperature must be reached within the time limit.

At test initiation an event is generated in the log.

During function and PTI test the normal alarm system remains active. If an alarm is triggered during test operation, it appears in the display and will be written in the log as it is the case during normal operation.

In case of a fatal alarm during testing the test is terminated and the unit remains off.

Function or PTI sub-test failure causes an alarm "PTI FAILURE" to be generated.

In case of Function or PTI sub-test pass an event, "Test status" is displayed.



For more information, please see event list.

Clear the alarm list before starting a test. If there should be any active alarms in the alarm list when a function or a PTI test is started, the test will always fail even if all the individual test steps PASS without failures.

PTI menu has a primary status and a status for each sub-test with own indexes. Only the primary status for a PTI test is memorized when supply voltage is removed. When PTI is initiated a Trip start is set in the data log.

Function test

Function test is a unit component test. (Non destructive)

Test is based on a GO/NO GO procedure. All tests must be executed without failure one by one for the function test result to be PASS.

Note: The tests can also be performed individually.

Note: If there is too much liquid in the compressor house before compressor test (part of the function test) the compressor test will fail because of high intermediate pressure. This liquid needs to be evaporized. Let the unit run under normal conditions for 10 min, and activate PTI or function test as usual after this.

Function test includes the following items:

1. PTI – init
2. Controller test
3. Power check
4. Evaporator fan (Mevap)
5. Condenser fan (Mcond)
6. Heating element (Hevap)
7. Probe check.
8. Compressor/FC/valve test (Vexpansion, Vhotgas and Veconomizer) - test descriptions as follows:

Compressor/valve test (Vexp, Vhg, Vecon)		
No	Test description (steps)	Passing conditions
80	Compressor High pressure switch test Pump down test	Max. duration 5 min Reached within max. 5 min. 20 Bar < Pdis < 24 Bar If error: AL250 Reached within max. 5 min. Tc - T0 > 20°C If error: AL845
81	Valve leak All valves, reed valves included	Max. duration 5 min T0diff < 25 °C If error: AL840
82	Vecon Testing capacity	Pfc > Pfc,stable + 10-40 % (-30°C - 20°C) Max. duration 2 min. Pfc < Pfc,stable + 10 % Max. duration 6 min. If error: AL843



83	<p>Vexp</p> <p>Testing capacity</p>	<p>Max. duration 5 min <u>When Pdis ≥ 5 Bar:</u> Max. change in Pdis ± 0.75 <u>When Pdis < 5 Bar:</u> Max. change in Pdis ± 0.3 <u>When Tret ≥ -15°C:</u> Min. change in T0 + 20 °K <u>When Tret < -15°C:</u> Min. change in T0 + 10 °K</p> <p>If error: AL842</p>
84	<p>Vhg (hot gas valve)</p> <p>Testing capacity</p>	<p>Max. duration 5 min <u>When Pdis ≥ 5 Bar:</u> Max. change in Pdis ± 0.75 <u>When Pdis < 5 Bar:</u> Max. change in Pdis ± 0.3 <u>When Tret ≥ -15°C:</u> Min. change in T0 + 20 °K <u>When Tret < -15°C:</u> Min. change in T0 + 10 °K</p> <p>If error: AL844</p>

9. Test completion / status

NOTE: At ambient temperature above 40°C (104°F) and below -20°C (-4°F) the unit has to be running in normal operating mode at setpoint of 0°C (32°F) for of 10 minutes with compressor running before executing a function test or PTI test.

The reason for this is to ensure correct function of unit during PTI test or function test.

PTI Test:

The purpose of the PTI test is to verify the presence of cooling performance.

The test is based on a GO/NO GO procedure. All tests must be executed without failure one by one for the PTI test results to be PASS.

PTI test includes the following test items:

Full PTI

1. Function test (see **Function test**)
2. 5°C (41°F) test
3. 0°C (32°F) run test
4. 0°C (32°F) hold test
5. -18°C (-0.4°F) run test
6. Defrosting
7. Test completion / status

Short PTI

Short PTI includes the following test items:

1. Function test
2. 5°C (41°F) test
3. 0°C (32°F) run test
4. 0°C (32°F) hold test
5. Defrosting
6. Test completion / status

Data Log

The controller has a data log to record operation of the unit. The data log includes 4 items:

- Data.



- Extended data.
- Alarms.
- Event data.

The logged data in the data log can be seen:

- On the display menu L01, the viewable temperatures are listed.
- On the display menu L03, the logged temperatures can be viewed graphically.
- Retrieved via the program RefCon and the RMM modem and the power line.
- Retrieved via a program, LogMan, on a PSION pda using the retriever socket.
- Retrieved via the StarView program using the retriever socket.

When an alarm is activated it triggers a complete log, however max. one per 15 min.

The datalogger can hold approximately 10.000 logs or more than 1 year of loggings with default logging interval of one log per hour.

The following tables show retrievables with Starview and Psion Logman software:

File Download Info			
F1		Signature	Header
F2		Container ID	
F3		Controller ID	
F4		Controller Software	
F5		Retriever Software	
F6		Extraction date	
F7		Comments	
Data log			
D1	DT	Date	Stamp
D2		Time	
D3		Log Type [Event, Data, Log]	
D4		Event ID	Events + Alarms
D5		Param. 1	
D6		Param. 2	
D7		Param. 3	
D8		Param. 4	
D9		Param. 5	
D10	Tsup	Supply Air Temperature [°C]	Short Log
D11	Tret	Return Air Temperature [°C]	
D12	Tusda1	USDA 1 Temperature [°C]	
D13	Tusda2	USDA 2 Temperature [°C]	
D14	Tusda3	USDA 3 Temperature [°C]	
D15	Tcargo	Cargo Temperature [°C]	
D16	Tset	Temperature Set Point [°C]	
D17	Humidity	Relative Humidity [%]	
D18	AirEx	Air Exchange [m3/h]	Extended Log Type 1
D19	Psuc	Suction Pressure [BarE]	
D20	Pdis	Discharge Pressure [BarE]	
D21	Fpower	Net frequency [Hz]	
D22	Upower	Highest power voltage of U1, U2, U3	
D23	I1	Current, Ph. 1 [A]	
D24	I2	Current, Ph. 2 [A]	
D25	I3	Current, Ph. 3 [A]	
D26	Ifc	FC current [A]	
D27	Fcpr	Compressor Frequency [Hz]	
D28	Heater	Heating element [%]	
D29	Mevap	Evaporator motor status	
D30	Mcond	Condenser motor status	
D31	Tfc	Frequency module Temperature [°C]	
D32	Tamb	Ambient Temperature [°C]	



D33	Extended Log Type 2	Extended Log Type 2
D34		
D35		
D36		
D37		
D38		
D39		
D40		
D41		
D42		
D43		

Header can be retrieved by Refcon, Logman, StarView and can be viewed in Refcon, LogView and StarView.

Extended Log Type 1 can only be retrieved by Logman and StarView and shown in LogView and StarView.

Extended Log Type 2 can only be retrieved by StarView and viewed in StarView.

StarView is the unique program designed for communication with a Star cool unit through a serial connection to a PC.

Alarm Action System (AAS)

This function defines what to do if a sensor is defect. The strategy is to substitute the missing sensors reading with the value from another sensor + a constant so that the unit can maintain its functionality with reduced precision.

Temperature control

Chill mode

Defect sensor(s)	Substitution sensor / Action	Alarm
Tsup1 (2)	Tact = Tsup2 (1)	
Tsup1 and Tsup2	Tact = Tret + constant	611, Too many sensor err
Tsup1, Tsup2 and Tret	Tact = Tevap + constant	
Tsup1, Tsup2, Tret and Tevap	**	600, No control sensor

Freeze mode

Defective sensor(s)	Substitution sensor / Action	Alarm
Tret	Tact = Tevap + constant	
Tret and Tevap	Tact = Tsup1 + constant	611, Too many sensor err
Tret, Tevap and Tsup1	Tact = Tsup2 + constant	
Tret, Tevap, Tsup1 and Tsup2	**	600, No control sensor

** = No more available sensors for substitution.

Expansion valve control

Defective sensor(s)	Substitution sensor / Action	Alarm
Psuc	Emergency injection	611, Too many sensor err
Tsuc	Emergency injection	611, Too many sensor err



Condenser fan control

Defective sensor(s)	Substitution sensor / Action	Alarm
Pdis	Start up: Condenser fan speed = slow Chill/Freeze mode: Condenser fan speed depends on ambient temperature.	
Tamb	Tamb = Tinternal	
Tret, Tevap and Tsup1	Tact = Tsup2 + constant	
Tamb and Tinternal	Tcmin	

Dehumidification control

If dehumidification is active:

Defective sensor(s)	Substitution sensor / Action	Alarm
RH	Stop dehumidification	614, Humidity deactivated

Defrost control

Defective sensor(s)	Substitution sensor / Action	Alarm
Tevap	Tsuc	
Tc	Tc = constant	
Psuc(T0)	T0 = Tevap	
Psuc (T0) and Tevap	Only electrical defrosting. T0 = constant	
Tsuc	Only electrical defrosting T0 = constant	
Tamb	Tinternal + constant	
Tamb and Tinternal	Always electrical defrosting	

Electrical control

Following graphical illustration shows the accepted volt/Hz range and the set off values for the alarms AL 414, AL 415, AL 416, AL 417, AL 418, AL 419, AL 427, AL 428 and AL 429, based on the table below.

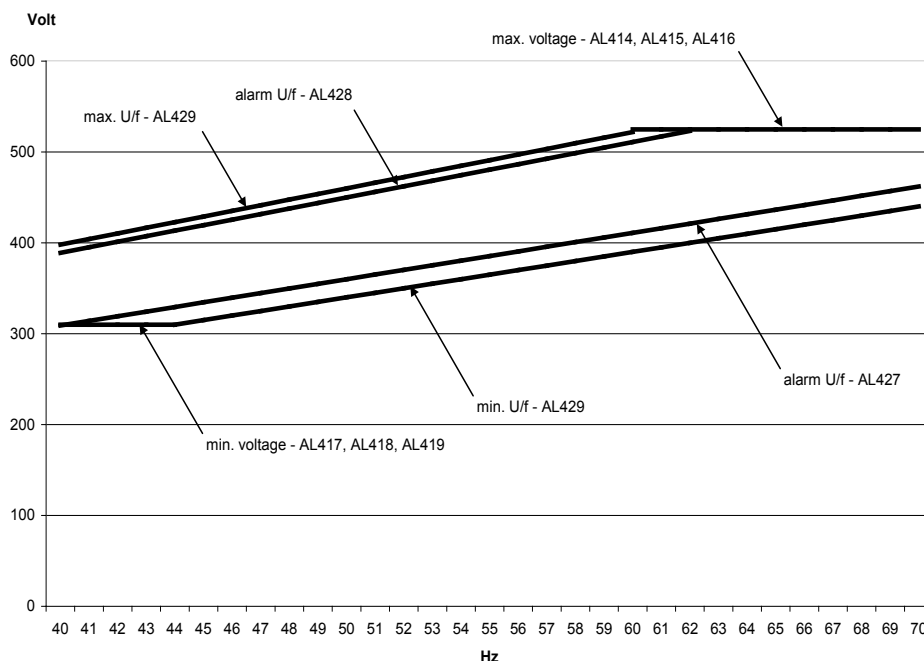



Frequency (f) [Hz]	AL417, AL418, AL419 Min. voltage (U) [V]	AL429 at voltage (U) [V] Fatal Alarm	AL427 at voltage (U) [V]	AL428 at voltage (U) [V]	AL429 at voltage (U) [V] Fatal Alarm	AL414, AL415, AL416 Max. voltage (U) [V] Fatal Alarm
40	335		288	388	403	525
41	335		294	394	409	525
42	335		300	400	415	525
43	335		307	407	422	525
44	335	296	313	413	428	525
45	335	302	319	419	434	525
46	335	308	325	425	440	525
47	335	314	331	431	446	525
48	335	321	338	438	453	525
49	335	327	344	444	459	525
50	335	333	350	450	465	525
51	335	339	356	456	471	525
52	335	345	362	462	477	525
53	335	352	369	469	484	525
54	335	358	375	475	490	525
55	335	364	381	481	496	525
56	335	370	387	487	502	525
57	335	376	393	493	508	525
58	335	383	400	500	515	525
59	335	389	406	506	521	525
60	335	395	412	512	527	525
61	335	401	418	518		525
62	335	407	424	524		525
63	335	414	431			525
64	335	420	437			525
65	335	426	443			525
66	335	432	449			525
67	335	438	455			525
68	335	445	462			525
69	335	451	468			525
70	335	457	474			525

Please note, that values may vary from values in previous software versions.

Refrigeration system data

Refrigerant charge, R134a

4.5 kg, with water cooled and non-water cooled condenser.



General specification

Total unit weight	Range from 400 to 460 kg depending on model		
Dimensions	Height: 2235 mm	Width: 2025 mm	
Noise level	Less than 75 dB(A) in 250 Hz band. Measured 1.5 m in front of unit and 1.2 m above the ground, with the unit operating at 50 Hz.		

Compressor – motor assembly

Type	Semi – hermetic two-stage reciprocating
Number of cylinders	2 Low stage cylinders 2 High stage cylinders
Speed	Variable, FC controlled
Model	S4BCF – 5.2Y.
Nominal power	5.5 kW
Compressor oil type	Reniso Triton SEZ 55 or equivalent
Compressor oil quantity	1.5 L + 0.4 L in system
Compressor housing	Sea water resistant aluminium, unpainted
Weight	58 Kg

Frequency converter (FC)

Type	FCM 375
Frequency range	15 – 110 Hz (450 – 3300 rpm)
Converter housing	Sea water resistant aluminium, unpainted
Tightness	IP 54

High Pressure cut – out switch

Cut – out	22.5 BarE (326.3 psi) ± 0.7 Bar (10.2 Psi)
Cut – in	15.9 BarE (230.6 psi) ± 0.7 Bar (10.2 Psi)

Fusible plug, receiver

Blow temperature	100°C (212°F)
------------------	---------------

Economizer

Type	Brazed plate heat exchanger
Material	Stainless steel, AISI 316 L

Evaporator coil

Tube material	Copper, inner grooved
Fin Material	Aluminium, Hydrophilic treated
Fin spacing	3.4 mm
Attitude	45° from horizontal



Condenser coil

Tube material	Copper, inner grooved
Fin Material	Aluminium
Fin spacing	2.0 mm
Coating, tube/fin	Cataphoresis treatment, with additional acrylic resin

Evaporator fan

Material	Polypropylene, glass fibre reinforced
Type	Axial
Number of fans / blades	2 pcs / 7 pcs
Pitch	25°
Diameter	ø315 mm
Drive	Direct on motor shaft

Condenser fan

Material	Polypropylene, glass fibre reinforced
Type	Axial
Number of fans / blades	1 pcs / 4 pcs
Pitch	30°
Diameter	ø400 mm
Drive	Direct on motor shaft

Water cooled condenser (optional)

Operating water pressure, max.	8 BarE (115 Psi)
Water temperature, max. cooling cap.	30°C (86°F)
Water flow rate	22.7 – 30.2 l/min. (6 – 8 gal/m)
Pressure drop	0.9 Bar (13.05 Psi) – 1.2 Bar (17.4 Psi) at above flow rate
Connections	Inlet: Hansen B-66 or equivalent. Outlet: Hansen B8-HP36-VAA or equivalent.
Condenser tubing	Cu – Ni (90/10)
Water specification	Fresh water or Salt water, without free chlorine

Defrosting

Defrost initiation

- On demand defrost.

Defrosting interval

- The on demand defrost system is constantly monitoring the temperatures for the evaporator in order to prevent that the evaporator will block up with ice. If a blocking up of the evaporator is registered by the system, a demand defrost will be initiated.
- The minimum time between defrost is always 4 hours, but it is adjusted to the actual set point.

Defrosting method: Hot gas, combined with electrical heaters.



Fresh air exchange

Fresh air exchange	Adjustable 0 – 220 m ³ /h (0 – 121 CFM) at 60 Hz. adjustable by steps of 5 m ³ /h. Equivalent to 0 - 170 m ³ /h (0 –100 CFM) at 50 Hz.
AV+ controlled (optional)	0 - 30 m ³ /h (50 Hz) controlled by the controller

Refrigeration controls

Expansion valves	2 solenoid valves, electronically controlled by the controller
Filter Drier	Danfoss DML 164 with O – ring or equivalent
Hot gas valve	Solenoid valve electronically controlled by the controller
Moisture indicator	Incorporated in receiver sight glass. Material: Brass acc. to EN 12164 / CW602N.
Piping	Solid copper tubes according to EN 12735 – 1
Pipe coating	Primer: Epoxy resin zf – a120. Top coat: Polyurethane resin Hipon – 50.

Electrical data

Input power (operational)	3 x 360 V - 460 V 50Hz / 3 x 400 V - 500 V 60 Hz
Control circuit voltage	12 V DC
AUX voltage AC: 19 - 30 V AC	24 V AC Nominal

Circuit Breaker

Main power ampere	16 A
-------------------	------

Contactors

Nominal	9 amp at 40°C (104°F) & 400 volt
Max	7 amp at 70°C (158°F) & 520 volt
Start current	6 x nominal

Fuses

Control circuit supply	0.4 A, tube fuse
------------------------	------------------

Power plug

Type	CEE 17.4 pole, with earth. 32 amp 400/460 V / 50/60 Hz
------	---

Power Cable

Type	4 x 2.5 mm ² , 450 / 750 V, PU – sheath
Length / colour	18 m / Yellow
Temperature Range	-37°C to +90°C (-34.6°F to 194°F)



USDA socket requirements

Location	Rear left side
Number	3 pieces + 1 cargo sensor
Type	Deutsch HD 10, female socket. Tin Plated

Evaporator fan motor

Manufacturer	Grundfos	ABB		
Type	Enclosed, non - vented, dahlander motor			
Frame size	071B14			
Shaft material	Stainless steel, X20CrNi172			
No. of motors	2			
Voltage	3 - phases, 400 / 460 Vac, 50/60 Hz			
Nominal power	0.45/0.07 kW at 460V/60 Hz		0.45/0.07 kW at 460V/60 Hz	
Protection, electrical	Thermistors			
Speed	Dual - speed 3460 / 2850 rpm (60/50 Hz) 1760 / 1425 rpm (60/50 Hz)		Dual - speed 3430 / 2890 rpm (60/50 Hz) 1750 / 1440 rpm (60/50 Hz)	
Rotation	Counter - clockwise, when viewed from shaft end			
Bearings	Permanently lubricated, sealed			
Bearing size	Drive end 6304 2Z C3	Non - drive end 6201 2Z C3	Drive end 6203 2CS C3	Non - drive end 6304 2CS C3
Bearing lubricant	Lubricant Klüberquiet BQH 72 - 102 or equivalent. Temp. range: -40°C to +140°C (-40°F to 284°F)			

Condenser fan motor

Manufacturer	Grundfos dahlander motor		ABB dahlander motor	
Type	Enclosed, non - vented			
Frame size	071B3			
Shaft material	Stainless steel, X20CrNi172			
No. of motors	1			
Voltage	3 - phases, 400 / 460 Vac, 50/60 Hz			
Nominal power	0,25/0,07 kW at 460V/60 Hz		0,30/0,08 kW at 460V/60 Hz	
Protection, electrical	Thermistors			
Speed	Dual - speed 1740 / 1460 rpm (60/50 Hz) 870 / 730 rpm (60/50 Hz)		Dual - speed 1710 / 1420 rpm (60/50 Hz) 830 / 690 rpm (60/50 Hz)	
Rotation	Counter - clockwise, when viewed from shaft end			
Bearings	Permanently lubricated, sealed			
Bearing size	Drive end 6204 2Z C3	Non - drive end 6201 2Z C3	Drive end 6203 2Z C3	Non - drive end 6202 2Z C3
Bearing lubricant	Lubricant Klüberquiet BQH 72 - 102 or equivalent. Temp. range: -40°C to +140°C (-40°F to 284°F)			



Evaporator coil heaters

Type	ø8,5 mm in stainless steel AISI 304
Number	6
Rating	750 W each at 400 V (750 W ±10 W)

Temperature sensors, including USDA

Type	NTC, 10 kOhm at 25°C (77°F) 10K3A1
Operating temp.	-40°C to 100°C (-40°F to 212°F)
Accuracy	±0.15°C, range -30°C to 100°C (±0.5°F, -22°F to 212°F)

Pressure transmitters

Manufacturer	Danfoss AKS 32R	SAGInoMIYA NSK
Range	0 – 32 BarE High pressure side. -1.0 – 12.0 BarE Low and intermediate pressure side	0 – 30 BarE High pressure side. -0.69 – 9.8 BarE Low and intermediate pressure side
Type	Ratio metric pressure transmitter, with sealed gauge measuring principle. ¼" in. female flare connection with deflator	

Miscellaneous

Tin plated electrical wires

Tin plated cables.

2 pieces of incorporated hinges.

2 pieces of removable evaporator hatches.

Bolts, screws and nuts in stainless steel.



Single viper peripheral seal.

Front frame is painted with polyester powder, colour Ral 9003.

Fresh air exchange is measured and logged in m³/h, definition 5 m³/h.

User Interface

Indicator lights

Alarm indicator light		In-range indicator light
SLOW FLASH if there are active alarms. QUICK FLASH if there are fatal alarms.	<p>Alarm</p>  <p>Red</p>	<p>In range</p>  <p>Green</p>
		NORMAL FLASH when controlling temperature probe is inside the acceptable range Constant ON after 30 min. in-range

Both lights only active when the container is connected to a power supply line.

During power up both lights are shortly illuminated to verify their function.

A "Slow flash" is a short flash every 3 sec. A "Quick flash" is a flash every 1 sec. A NORMAL FLASH is a flash every 1½ sec.



Display

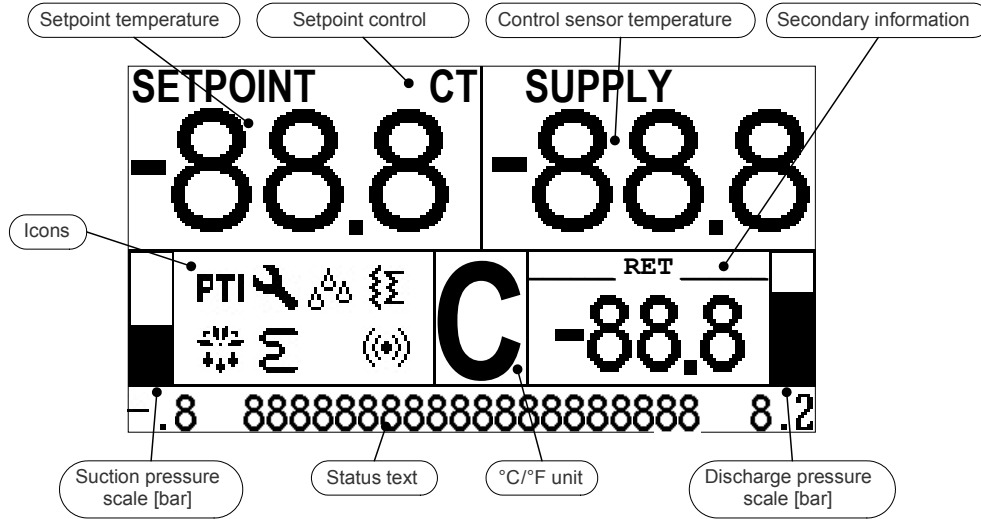

C / F	Temperature and pressure unit selection Celsius + Bar or Fahrenheit + Psi
PTI	Pre Trip Inspection or Function Test is running
	Unit is operated in service mode
	Humidity control is activated
	Water cooled condenser is activated
	Defrosting is running
	Heater elements are switched on
	Alarms are present in the alarm menu
CT	Setpoint is controlled by Cold Treatment, CT program
MTS	Setpoint is controlled by Multiple Temperature Set points, MTS program

It is possible to obtain a datalog graph display ("Datalog view:" p. 46)

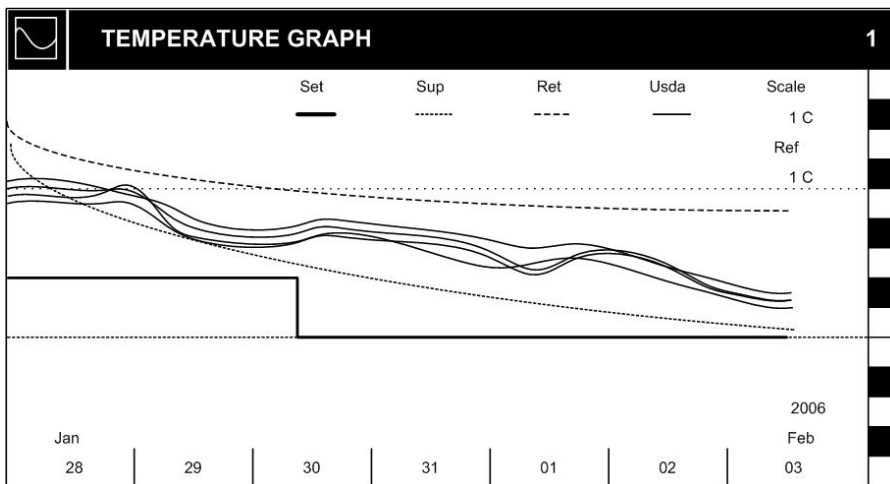



Key pad

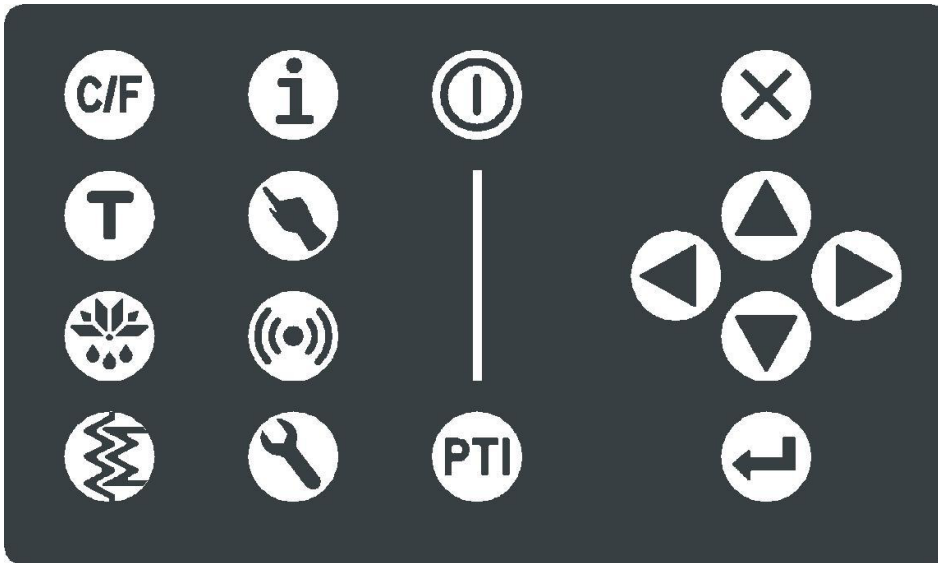

Navigation keys		Use these keys to move menu display up / down and to change parameter values
	Cancel	Leave active sub menu Cancel active parameter adjustment
	Up	Move menu one line up Increment parameter value in menu Increment setpoint on main display page Zoom out (graphical view)
	Down	Move menu one line down Decrement parameter value in menu Decrement setpoint on main display page Zoom in (graphical view)
	Left	Move menu one line to the left Move left (graphical view)
	Right	Move menu one line to the right Move right (graphical view)
	Enter	Select a sub menu Activate a function (press twice) Initiate parameter adjustment Accept parameter adjustment when done
Menu keys		Press key to select menu display Press again to move menu one full page down
	Wake-up	Turn on and off battery powered display operation No display backlight will be active
	PTI	Show PRE TRIP INSPECTION menu (start/stop test and view results)
	Info	Show INFORMATION menu (actual data read out)
	Operation	Show OPERATION menu (settings)
	Alarm	Show ALARM menu (view listing of present alarms)
	Service	Show SERVICE menu (maintenance data and settings)



Function keys		Direct activation and deactivation of commonly used functions
	Unit	As long as the button is pressed, °F is shown instead of °C and Psi is shown instead of Bar in the display. Otherwise °C and Bar is shown when pressed if software is set to °F/Psi default
	Toggle	Shortcut to graphical view of logged temperatures. Toggles information on some sub menus.
	Defrost	Press 3 sec. to start and stop a manual defrost cycle
	Water Cool	Press 3 sec. to activate and deactivate water cooled condenser

If no key is activated for a period of time, the controller will do this:

- 5 sec.: Cancel active parameter adjustment
- 30 sec.: Turn off battery powered display operation when not connected to a power supply line
- 5 min.: Leave service mode operation and return to automatic mode
- 10 min.: Return to main window in display

Menu overview

Menus are selected by pressing a menu key or by pressing the Enter key on a sub menu line shown in the display.

General Page layout

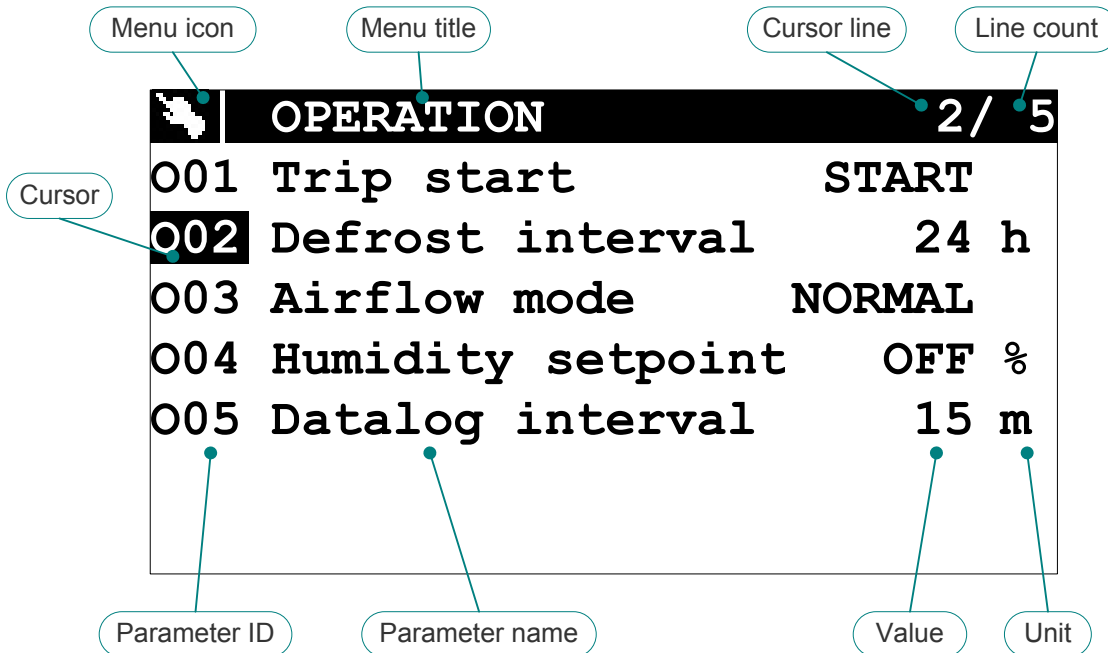



Using the cursor

The parameter ID is only used for identifying each displayed line of the menu system.

Pressing the ▲ and ▼ arrow keys will move the highlighted cursor one menu line up or down.

In the upper right corner of the display is shown the actual line number of the cursor together with the total number of lines in the current menu.

Changing a parameter value

1. First move the cursor up, press ▲ or down, press ▼ to the line of the parameter to be changed.
2. Then press the Enter key ↵ . The cursor will now highlight the parameter value instead of the ID.
3. Use the Up or Down arrow keys to increase or decrease the displayed value.
4. Accept the new parameter value by pressing the Enter key ↵ once more.
5. If not pressing any key for 5 sec. or if pressing the Cancel key ⊗, the value will not be changed.
6. The cursor returns to the ID column and can now be moved to other lines.

Activating a function

1. First move cursor Up press ▲ or Down press ▼ to the line of the function to be activated.
2. Then press the Enter key ↵ . The cursor will now highlight the function value instead of the ID.
3. Do the activation by pressing the Enter key ↵ once more.
4. If not pressing any key for 5 sec. or if pressing the Cancel key ⊗, no function will be activated.
5. The cursor returns to the ID column and can now be moved to other lines.

Air exchange page

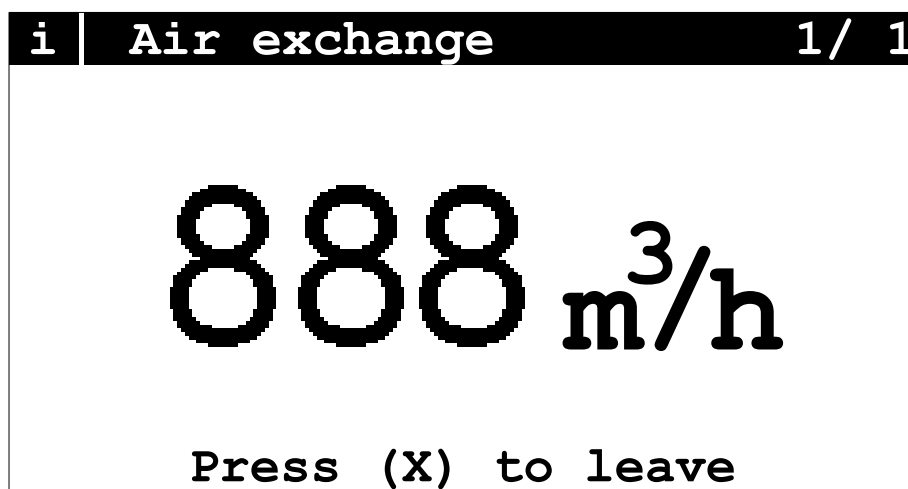

This page is automatically displayed when the user starts changing the air exchange valve position.

The display returns to the main page after 10 min. or when the Cancel key is pressed.

To view actual airflow at a different time use information menu I02



Operation

Menu Structure

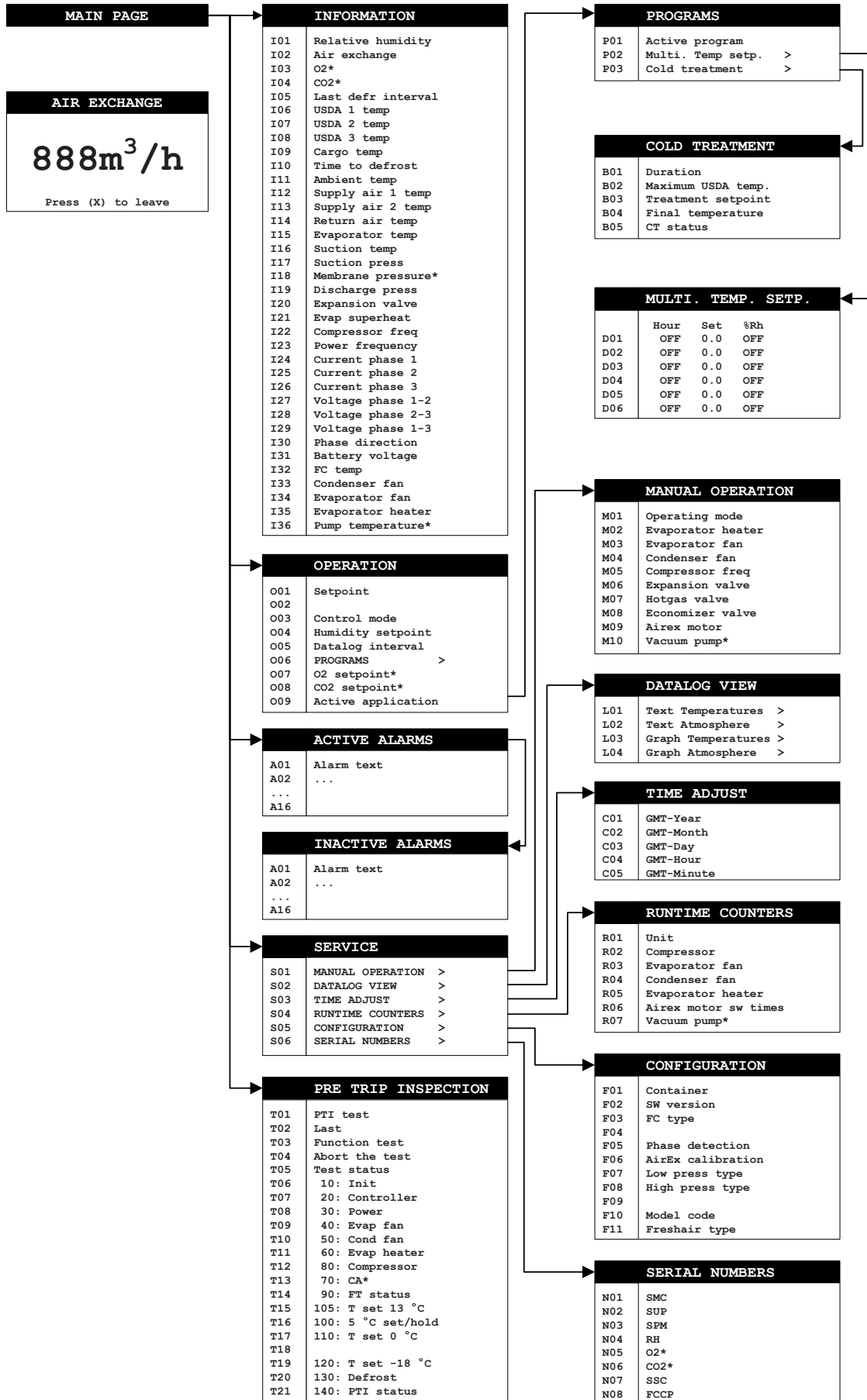

*Only for some models



General Operation

The following text is a general description of operating menus and editing parameters.

By pressing a menu key the menu is selected and its icon is illuminated.

The lower part of the display shows parameter number, parameter value and a short information text in English.

After 30 sec. with no keyboard activities, the display returns to the main display menu. By pressing the display returns to the previous menu level in the menu structure.

If one of the other menu keys is pressed, menu selection changes.

By pressing the and keys the individual parameters are scroll able.

For parameter change, press and the parameter is highlighted in inverse writing. By pressing and keys parameter values are changeable.

When desired value is set, press to accept value and parameter is shown in normal writing again.

As long as the parameter value is shown in inverse writing, setting is erasable by pressing and the previous parameter value is shown again.

If the keys , or are not pressed for 5 sec., setting is cancelled and the previous parameter value is shown again.

Temperature Setting

Temperature set-point adjustment is made from the operating menu.

By pressing or the set-point is adjusted 0.1°C (0.1°F) and the set-point digits are highlighted in inverse writing.

If the key is held, the set-point will automatically be incremented by 0.1°C (0.1°F) until the key is no longer held. After approximately 3 sec. the set-point will be incremented by 1°C (1°F). Upon reaching desired temperature, press and hold for 3 seconds. The set-point will be accepted and shown in normal writing again.

During inverse writing, the new temperature set-point is erasable by pressing and the previous set-point is shown again.

If the keys , or are not pressed for 5 sec., current setting will be cancelled and previous set-point shown again.

Wake-up Mode

When no main power is present the controller is switched off.

The controller includes a battery for "Star Cool" operation when no external voltage supply is present.

For battery saving in this situation, controller will turn itself off upon disappearance of external voltage supply.

By pressing controller is enabled and controller operation will be possible. In case of no keyboard activities for 30 sec., controller will be turned off again.

Controller may be manually turned off in this mode by pressing again.

Contrast adjustment of the display

Press and hold while pressing or to adjust contrast, and or to adjust background lighting of the display. This can be done both in battery mode and when main power is applied. After adjusting the contrast, wait for a period of 25 sec before proceeding for the new setting to be saved. **Make sure contrast is properly set at all times to secure readability.**



PTI or Function Test execution PTI

The test menu is opened by pressing PTI. In the test menu, press keys ▲ or ▼ to scroll the menu.

For a complete PTI test START must be highlighted by pressing ↵ at menu item T01. Pressing ↵ once more initiates the test. If ↵ is not pressed within 5 sec., the controller will cancel the operation and the cursor returns to the menu item – T01.

For a short PTI test START must be highlighted by pressing ↵ at menu item T01. Press keys ▲ or ▼ to scroll the menu to select SHORT. Pressing ↵ once more initiates the test.

A complete PTI test may take several hours: First a complete function test with menu items T04 to T12 and then performance testing in menu items T13 to T17.

A short PTI takes approx. 1.5 hours.

Function test is initiated in the same way by selecting menu T02. A function test performs menu items T04 to T12, without performance testing and takes about 10 – 15 min. to complete. The function test will continue through all the steps even if failures should occur. A PTI or function test can be aborted at T03.

A single item can be tested by highlighting the item, ex. T09. When START is shown in inverse writing, pressing ↵ again will start the test. Only the selected item is tested.

The PTI test is automatically terminated in case of no errors. Finally, temperature set-point will be set to the same value as before test initiation.

If any error occurs during the test, alarms will be shown in the alarm list. Active alarms in the alarm list before start of the PTI test will lead to failure of the PTI test:

1. One alarm for PTI or function test failure. Status are also listed in the menu items T04 – T12(FT)/T18(PTI).
2. One or more alarms for a specific error during the test. Only listed in alarm list.

Failures found during the tests are listed in the alarm list and the results of the separate PTI test steps are in menu items T04 to T18. Alarms found are logged in the datalog.

A detailed description and trouble shooting of an alarm can be found in this manual "Detailed alarm description" p. 57, together with a description of the specific test alarms "Test Alarms (AL 8XX)" p. 148. When the PTI test completes or is aborted, all alarms found during the test are set inactive in the alarm list.

If the alarm list is empty, the unit is completely OK.

If the controller is switched off, only the main status of a PTI test is remembered in menu item T04.

T01 PTI test start (PTI test)

Function:

Start Pre-Trip-Inspection test run to verify full functionality of the unit and performance test at different set point temperatures.

Value:

For starting PTI test, select either NORMAL or SHORT via ▲ or ▼ and press ↵ which initiates the test.

The PTI test is automatically terminated in case of no errors. Finally, temperature set-point will be set to the same value as before test initiation.

T02 Last

Function:

Type and date of latest past PTI

Value:



YYYY-MM-DD FULL, SHORT or ---- (if failed)

T03 Function test start (Function test)

Function:

Start function test runs to verify full functionality of the unit without performance tests.

Value:

For starting function test, START must be highlighted by pressing . Pressing once more initiates the test.

T04 Abort the running test (Abort the test)

Function:

Stop the running PTI or function- test.

Value:

To stop the running test, STOP must be highlighted by pressing . Pressing once more stops the test.

T05 Test status (Test status)

Function:

Shows the status of the last/running test:

Value:

The value depends on the function running.

For PTI the values can be: "RUN" for running, "PASS" for test passed successfully, "ABORT" for test aborted by a user, "FAIL" for a failing PTI test – see the alarm list for specific reason.

T06 Test result: 10 Init (10 Init)

Function:

Shows the status of the test initialization. This test is always done

Value:

"-" if not done yet. "RUN" if still running test. "PASS" if test finished successfully. "FAIL" if the test failed. "ABORT" if the test was aborted by the user.

T07 Test result: 20 Controller (20 Controller)

Function:

Shows the status of the test of the controller.

Value:

"-" if not done yet. "RUN" if still running test. "PASS" if test finished successfully. "FAIL" if the test failed. "ABORT" if the test was aborted by the user. See specific description for AL 801 "Test Alarms (AL 8XX)" p. 148

T08 Test result: 30 Power (30 Power)

Function:

Shows the status of the test of power consumption/connection.

Value:

"-" if not done yet. "RUN" if still running test. "PASS" if test finished successfully. "FAIL" if the test failed. "ABORT" if the test was aborted by the user. See specific description for AL 805

T09 Test result: 40 Evap fan (40 Evap fan)

Function:

Shows the status of the test of the evaporator fans.

Value:

"-" if not done yet. "RUN" if still running test. "PASS" if test finished successfully. "FAIL" if the test failed. "ABORT" if the test was aborted by the user. See specific description for AL 810 - 813

T10 Test result: 50 Condenser fan (50 Cond fan)

Function:

Shows the status of the test of the condenser fan.

Value:



"-" if not done yet. "RUN" if still running test. "PASS" if test finished successfully. "FAIL" if the test failed. "ABORT" if the test was aborted by the user. See specific description for AL 815 - 817

T11 Test result: 60 Evaporator heater (60 Evap heater)

Function:

Shows the status of the test of the evaporator heater.

Value:

"-" if not done yet. "RUN" if still running test. "PASS" if test finished successfully. "FAIL" if the test failed. "ABORT" if the test was aborted by the user. See specific description for AL 820 - 821

T12 Test result: 80 Compressor (80 Compressor)

Function:

Shows the status of the test of the compressor.

Value:

"-" if not done yet.

"RUN" if still running test.

"PASS" if test finished successfully.

"FAIL" if the test failed.

"ABORT" if the test was aborted by the user. See specific description for AL 845 and 846

T14 Test result: 90 FT status (90 FT status)

Function:

Shows the status of the function test.

Value:

"-" if not done yet. "RUN" if still running test. "PASS" if test finished successfully. "FAIL" if the test failed. "ABORT" if the test was aborted by the user.

T16 Test result: 100 Temperature set point 5°C (100 T set 5°C)

Function:

Shows the status of the performance test with temperature set point of 5°C (41°F)

Value:

"-" if not done yet. "RUN" if still running test. "PASS" if test finished successfully. "FAIL" if the test failed. "ABORT" if the test was aborted by the user. See specific description for AL 855

T17 Test result: 110 Temperature set point 0°C (110 T set 0°C)

Function:

Shows the status of the performance test with temperature set point of 0°C (32°F).

Value:

"-" if not done yet. "RUN" if still running test. "PASS" if test finished successfully. "FAIL" if the test failed. "ABORT" if the test was aborted by the user. See specific description for AL 860

T18 Test result: 111 Hold temperature at 0°C (111 Hold 0°C)

Function:

Shows the status of the performance test with holding temperature set point of 0°C (32°F).

Value:

"-" if not done yet. "RUN" if still running test. "PASS" if test finished successfully. "FAIL" if the test failed. "ABORT" if the test was aborted by the user. See specific description for AL 860

T19 Test result: 120 Temperature set point -18°C (120 T set -18°C)

Function:

Shows the status of the performance test with temperature set point of -18°C (-0.4°F).

Value:

"-" if not done yet. "RUN" if still running test. "PASS" if test finished successfully. "FAIL" if the test failed. "ABORT" if the test was aborted by the user. See specific description for AL 870



T20 Test result: 130 Testing of defrost (130 Defrost)

Function:

Shows the status of the performance test of defrost.

Value:

"-" if not done yet. "RUN" if still running test. "PASS" if test finished successfully. "FAIL" if the test failed. "ABORT" if the test was aborted by the user. See specific description for AL 870

T21 Test result: 140 PTI status (140 PTI status)



Function:

Shows the status of the PTI test.

Value:

"-" if not done yet. "RUN" if still running test. "PASS" if test finished successfully. "FAIL" if the test failed. "ABORT" if the test was aborted by the user. See specific description for AL 850

Info Menu Viewing

By pressing  the info menu is selected. The  icon is displayed.

The info menu includes the following parameters:

I01 Relative humidity (Relative humidity)

Function:

Shows current relative humidity in the container.

Value:

Shown as a percent value.

I02 Air exchange in m3/h (Air change m3/h)

Function:

Shows current opening of air exchange valve.

Value:

Shown as m3/h.

I05 Last defrost interval (Last defr interval)

Function:

Show current interval between last two defrostings.

Value:

Shown in hours.

I06 USDA 1 temperature (USDA 1 temp)

Function:

Shows current temperature for USDA 1 sensor.

Value:

Shown in temperature scale °C or °F. Switch by pressing .

I07 USDA 2 temperature (USDA 2 temp)

Function:

Shows current temperature for USDA 2 sensor.

Value:

Shown in temperature scale °C or °F. Switch by pressing .

I08 USDA 3 temperature (USDA 3 temp)

Function:

Shows current temperature for USDA 3 sensor.

Value:



Shown in temperature scale °C or °F. Switch by pressing .

I09 Cargo temperature (Cargo temp)

Function:

Shows current temperature for cargo sensor.

Value:

Shown in temperature scale °C or °F. Switch by pressing .

I10 Time to next defrost (Time to defrost)

Function:

Shows current time to the next defrosting.

Value:

Shown in hours and minutes.

I11 Ambient temperature (Ambient temp)

Function:

Shows current ambient temperature.

Value:

Shown in temperature scale °C or °F. Switch by pressing .

I12 Supply air 1 temperature (Supply air 1 temp)

Function:

Shows current temperature for supply 1 sensor.

Value:

Shown in temperature scale °C or °F. Switch by pressing .

I13 Supply air 2 temperature (Supply 2 air temp)

Function:

Shows current temperature for supply 2 sensor.

Value:

Shown in temperature scale °C or °F. Switch by pressing .

I14 Return air temperature (Return air temp)

Function:

Shows current temperature for return sensor.

Value:

Shown in temperature scale °C or °F. Switch by pressing .

I15 Evaporator temperature (Evaporator temp)

Function:

Show current temperature for evaporator.

Value:

Shown in temperature scale °C or °F. Switch by pressing .

I16 Suction temperature (Suction temp)

Function:

Shows measured suction gas temperature.

Value:

Shown in temperature scale °C or °F. Switch by pressing .

I17 Suction pressure (Suction press)

Function:

Shows current suction pressure for compressor.

Value:



Shown in units of Bar or Psi relative to atmosphere pressure. Switch by pressing C/F (at °C pressure is shown in BarE, at °F in Psi).

I18

Function:

Reserved for future use.

Value:

I19 Discharge pressure (Discharge press)

Function:

Shows current discharge pressure for compressor.

Value:

Shown in units of Bar or Psi relative to atmosphere pressure. Switch by pressing C/F (at °C pressure is shown in BarE, at °F in Psi).

I20 Expansion valve opening (Expansion valve)

Function:

Shows current percentage of expansion valve opening. **Pulse Wide Modulation**

Value:

Shown as a percent value.

I21 Evaporator superheat (Evap superheat)

Function:

Shows current superheat of expansion valve. $T_{suc} - T_0 = SH$

Value:

Shown in temperature scale °C or °F. Switch by pressing C/F . Value is only user-changeable with system in the service mode.

I22 Compressor frequency (Compressor freq)

Function:

Shows current compressor frequency.

Value:

Shown in units of Hz.

I23 Power frequency (Power frequency)

Function:

Shows current power (net) frequency.

Value:

Shown in units of Hz.

I24 Current consumption phase 1 (Current phase 1)

Function:

Shows actual current consumption on phase 1 for the unit excluding the compressor.

Value:

Shown in units of ampere.

I25 Current consumption phase 2 (Current phase 2)

Function:

Shows actual current consumption on phase 2 for the unit excluding the compressor.

Value:

Shown in units of ampere.

I26 Current consumption phase 3 (Current phase 3)

Function:

Shows actual current consumption on phase 3 for the unit excluding the compressor.

**Value:**

Shown in units of ampere.

I27 Voltage between phase 1 and 2 (Voltage phase 1->2)**Function:**

Shows current voltage between phase 1 and 2.

Value:

Units in volt.

I28 Voltage between phase 2 and 3 (Voltage phase 2->3)**Function:**

Shows current voltage between phase 2 and 3.

Value:

Shown in units of volt.

I29 Voltage between phase 1 and 3 (Voltage phase 1->3)**Function:**

Shows current voltage between phase 1 and 3.

Value:

Shown in units of volt.

I30 Phase direction (Phase direction)**Function:**

Shows current phase sequence.

Value:

Shown as CW or CCW or None. Value is not user-changeable. If AL 423 "No phase direction" go to configuration F05 for settings.

I31 Battery voltage (Battery voltage)**Function:**

Shows current Battery voltage.

Value:

Shown as voltage.

I32 Frequency Converter temperature (FC temp)**Function:**

Shows current converter temperature.

Value:

Shown in temperature scale °C or °F. Switch by pressing .

I33 Condenser fan speed (Condenser fan)**Function:**

Shows current speed for condenser fan.

Value:

Shown as OFF, LO, HI or OH (overheat).

I34 Evaporator fan speed (Evaporator fan)**Function:**

Shows current speed for evaporator fan.

Value:

Shown as OFF, LO, HI or OH (overheat).

I35 Evaporator heating (Evaporator heater)**Function:**



Shows current on/off-cycle of evaporator heating element. **Pulse Wide Modulation**

Value:

Shown as a percent value "on" during runtime. Cycle duration is 50 sec.



Operation Parameter Setting

By pressing  the operation menu is selected. The  icon is displayed.

Use the arrow keys  and  to navigate and the Enter key  to select.

Operation menu includes the following parameters:

001 Setpoint (Setpoint)

Function:

The function is used for changing the setpoint.

Change the value to the desired value and press the enter button,  for 3 seconds to acknowledge.

Value:

002 QUEST (optional)

Function:

AUTO/OFF

Value:

003 Control mode (Control mode)

Function:

Setting the control modes: NORMAL or ECONOMY mode.

If NORMAL mode is selected:

In chill mode the fans run at high speed.

In frozen mode the fans run at low speed.

The evaporator fans switch to use low speed whenever

- a) The setpoint is more than (>) 0°C (32°F)
- b) The air exchange is closed
- c) Dehumidification is off

If ECONOMY mode is selected:

Evaporator fans run at constant low speed.

The operator switches manually to economy mode

Value:

Function set to NORMAL, ECONOMY. Default is NORMAL.

004 Reference relative humidity setting (Humidity setpoint)

Function:

Setting of reference relative humidity. Note that container relative humidity is only reducible.

Value:

Shown as 'Off' or a percent value. Value can be set to Off or values from 50% to 95% in 1% increments. Default = off.

005 Datalog interval setting (Datalog interval)

Function:

Setting of interval between loggings in the data log.

Setting the datalog interval to 60 min. (default value) allows logging of data for over a year.

Value:

Interval set to 15, 30, 60, 120 or 240 min. Default 60 min.

Programs:

006 (Programs selection menu) (PROGRAMS)

Function:

Leads to the programs sub-menu.

Value:



Go to the programs sub menu.

009 Active application (Active application)

Function:

Actual application

Value:

-

P01-P03 Show/select active program (Active program)

Function:

Shows active program or activates selected program.

Attention: Program set points have to be set before activating the program is activated.

Value:

Shown as None, CT or MTS. Press  for 3 seconds to activate selected program or stop an active program by selecting None.

Values: NONE, CT and MTS.

Multiple Temperature Set points program, MTS

D01-D06 Settings per step (Hours Set %RH)

Function:

Settings for step 1 to 6 of the Multiple Temperature Set points program.

Value:

D01 – D06: Step number 1 – 6:

Hours: Defines how many hours the temperature set point is used (from 1 to 999 hours). When set point from "Set" is in-range, the time starts.
Setting Hours to Off clears all settings in this step and the succeeding steps.

Set: The set point temperature to use for this step.
Temperature change per hour (ramp) is fixed for cooling, and change is done with maximum cooling capacity available.

%RH: De-humidification - humidity set point. Values: Off, 50% – 95%. Off means the controller maintains as high humidity as possible, at all other values the controller will use the humidity set point to maintain de-humidification. De-humidification is active immediately when the step starts including under temperature ramps.

If the duration (hours) is set to OFF or it is the last step, the program is terminated. After this the unit continues with the temperature set as last step in the MTS.

The Multiple Temperature Set points program stops automatically if the unit has been powered off for more than 48 hours, or if the user stops the program or if PTI or Cold Treatment is initiated.



Cold Treatment program, CT

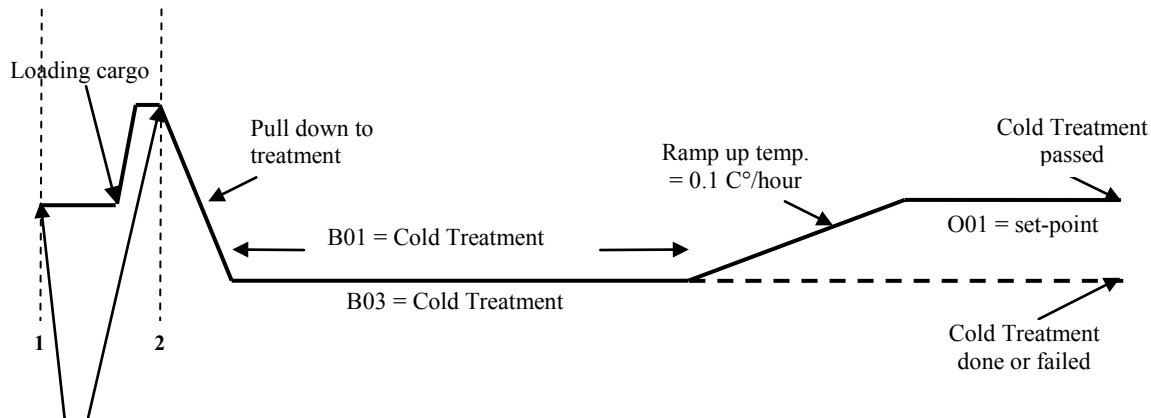

Start cold treatment at 1 or 2

Cold Treatment can only be started when all Tusda sensors are in function.

If one or more Tusda sensors fail under the Cold Treatment period, the treatment temperature is kept as set point for the whole trip. When Cold Treatment is done without any sensor failure, CT pass is written in the display status text. When Cold Treatment is done with 1 or 2 sensor failures, CT done is written in the display ("Display" p. 27). When Cold Treatment is done with 3 sensor failures, CT fail is written in the display ("Display" p. 27).

The CT-status will be displayed until:

- Program status set to none
- Initiated PTI
- Power off more than 48 hours

Termination of an active CT can only be done by manually setting active program (P01) to none or if the unit has been powered off for more than 48 hours.

Datalog interval during CT is default 60 min. (cannot be changed).

Changes in Treatment set point during active Cold Treatment has been limited to a decrement of -2.5°C (4.5 °F) to an increment of up to max. allowable set-point from original Treatment set point.

B01 Duration of the treatment (Duration)

Function:

Setting of duration in days of the Cold Treatment

Value:

Values 1 – 99 days. The number of days to use depends on the cargo and the treatment temperature.

The treatment time is counted from the validity of at least 3 USDA sensors all showing a temperature below the maximum USDA temperature. If one or more USDA sensors is outrange and returns to inrange again, the timer for the Cold Treatment will reset. CT passed shows that all USDA sensors have been under maximum allowed temperature in the duration time in one period.

B02 Maximum allowed temperature for the USDA sensors (Maximum USDA temp)

Function:

Setting of the maximum allowed temperature of the USDA sensors.

Value:

Value: -10.0°C to +30.0°C.

B03 Treatment setpoint (Treatment setpoint)

Function:

Setting of the setpoint during the treatment.

Value:

Value: -10.0°C to +30.0°C.

The setpoint must be chosen so that all USDA sensors show a temperature below the maximum USDA temperature during treatment.



B04 Final temperature (Final temperature)

Function:

Setting of final setpoint

Value:

Value: -10.0°C to +30.0°C.

After the treatment period the cargo might need to be warmed up to a higher temperature. The setpoint is increased by 0.1°C per hour until the final temperature is reached. When the final temperature is reached, the Cold Treatment program is finished and stops automatically and the "CT" sign on the main menu disappears.

B05 Status of cold treatment program (CT status)

Function:

Shows status of the CT program.

Value:

Values: Not active, Active, Aborted, Pass, Done, Fail.

The Cold Treatment program stops automatically if the unit has been powered off for more than 48 hours.

USDA

Function:

The bottom line shows the temperatures of USDA sensors 1 – 3 and the cargo sensor.

Value:

Actual temperature measured of the sensor.

-70°C indicates that the sensor is not mounted! Check alarm list to see if there should be an USDA alarm.

Alarms

The alarm list holds all active and inactive alarms.

By pressing the alarm menu is opened. The icon is displayed in upper left corner of the display. With any alarms in the list the icon is displayed on the main menu.

Alarm handling is to protect the unit with cargo and inform the user in case of error conditions. The main priority is to keep cargo safe.

Alarm handling is split in 2 parts:

1. Detect an abnormal situation and report it as an alarm.
2. React on the alarms and compensate for them (AAS - Alarm Action System).

An alarm can have 4 different levels.

- Log: Information for service. Only in the datalog, not on the display.
No risk for the cargo.
- Warning: Warning of an abnormal situation, but the unit continues to operate with unchanged or little change in functionality in actual running mode.
No risk for the cargo.
- Alarm: The unit operates with reduced or changed functionality.
Risk for the cargo.
- Fatal Alarm: The unit needs service now!
Serious risk for the cargo!

All errors in the 4 levels can have two states: Active or Inactive.

- Active: The alarm is active.
- Inactive: The alarm is no longer active. The alarm can be acknowledged from the alarm list.

The 4 alarm levels will be treated by the controller in the following way:



Alarm type	Datalog	Alarm list	Red LED	Cargo risk
Log	Yes	No	OFF	No risk for the cargo
Warning	Yes	Yes	OFF	No risk for the cargo
Alarm	Yes	Yes	SLOW FLASH 2% ON, 98 % OFF Duty time of 3 sec	Risk for the cargo
Fatal Alarm	Yes	Yes	QUICK FLASH 80% ON, 20 % OFF Duty time of 1 sec	Serious risk for the cargo!

Alarm handling is made to detect abnormal situations, possibly solve problems and report the problems. The alarm types indicate for the operator how severe the problem is for the safety of the cargo.

Some problems are fluctuant where the problem may be fixed if the unit restarts. Some of the alarms are only warnings but will restart the unit to try to solve the problem. There is an individual time out period for the alarms. A warning will not stop the unit permanently!

If a problem with warning type continues to be active over a period, the problem seems to be of a more stable and therefore more severe character and another alarm is triggered with alarm type Alarm.

The **AAS - Alarm Action System** will substitute a missing or malfunctioning sensor with one of the other sensors and thereby try to keep the cargo safe and well as long as absolutely possible. The substitution may lead to a deteriorated control precision, especially in the freeze mode, but the unit is not stopped fully until there are no further sensors to substitute with. The unit may try to restart to see if the malfunctioning is fluctuant.

For example if there is no substitution for a sensor or the substitute sensor is also faulty, alarm "**611 Too many sensor err**" is raised and the specific sensor(s) are listed separately in the alarm list.

The alarm list can include a maximum of 16 active/inactive alarms.

In case of an empty alarm list, + "No alarms" is shown.

An active alarm is shown as Acc AAnn, where cc is the list number from 01 to 16, and nnn is the actual alarm number.





An inactive alarm is shown as Acc IAnn, where cc is the list number from 01 to 16, and nnn is the actual alarm number.

An active alarm is not deletable from the list, but may change to inactive state by eliminating the cause of the alarm.

An inactive alarm is deletable from the list by pressing  during alarm displaying.

Service Function Setting/Viewing

By pressing  the service menu is selected. The  icon appears in the display.

Service menu consists of various sub-menus. Use the arrow keys  and  to navigate and the Enter key  to open a sub-menu. By pressing , the display returns to service menu.

Service menu consists of the following sub-menus:

- Manual operation (M01 – M10) Manual start/stop of motors etc.
- Datalog view (L01 – L04) View of temperature log.
- Time adjust (C01 – C05) Setting of date and time.
- Run time counters (R01 – R07) View of running hours for unit, comp. etc.
- Configuration (F01 – F11) Software version and various configurations
- Serial numbers (N01 – N08) Serial number for various parts



Manual operations:

M01 Operating mode (Operating mode)

Function:

Start/stop of operating mode.

If operating mode is MANUAL, controller stops, and by means of menu items M02 to M08 heaters, motors and valves may be manually operated. In menu item M05 compressor frequency is set. In case of no keyboard activities for 5 min., manual mode is automatically deactivated and unit starts automatically up.



Note that the "Star Cool" should only be set in the manual mode by trained service personnel!

Value:

Set to MANUAL or AUTOMATIC.

The bottom line on the menu shows the current consumption in the three phases (fan motor and heater) and for the frequency converter I1, I2, I3, FC.

M02 Turn the evaporator heater on/off (Evaporator heater)

Function:

Manual heater on/off. Note that value is only accepted if control is in the manual mode (menu item M01 is MANUAL).

Value:

0 - 100 % or OFF.

M03 Turn the evaporator fan on/off (Evaporator fan)

Function:

Manual evaporator fan on/off. Note that value is only accepted if control is in the manual mode (menu item M01 is MANUAL).

Value:

Set to OFF, LO (low speed) or HI (high speed).

M04 Turn the condenser fan on/off (Condenser fan)

Function:

Manual condenser fan on/off. Note that value is only accepted if control is in the manual mode (menu item M01 is MANUAL).

Value:

Set to OFF, LO (low speed) or HI (high speed).

M05 Setting of compressor frequency/capacity (Compressor freq)

Function:

Manual setting of compressor frequency. Note that value is only accepted if control is in the manual mode (menu item M01 is MANUAL).

MANUAL: Compressor frequency is set.

Value:

MANUAL: Set to OFF (compressor stop) or value between 15 and 110 Hz.

M06 Setting of expansion valve % opening (Expansion valve)

Function:

Manual setting of expansion valve % opening. Note that value is only accepted if control is in the manual mode (menu item M01 is MANUAL) and compressor is not running.

Value:

Set from 0 to 100%.

M07 Setting of hot gas valve % opening (Hot gas valve)

Function:

Manual setting of hot gas valve % opening. Note that value is only accepted if control is in the



manual mode (menu item M01 is MANUAL).

Value:

Set from 0 to 100%.

M08 Setting of economizer valve % opening (Economizer valve)

Function:

Manual setting of economizer valve % opening. Note that value is only accepted if control is in the manual mode (menu item M01 is MANUAL).

Value:

Set from 0 to 100%.

M09 AirEx motor

Function:

Opening

Value:

0-100%

Datalog view:

L01 Viewing log of temperatures (Temperatures)

Function:

Viewing of logged temperatures.

Value:

The following temperatures can be viewed: Setpoint temperature, supply air temperature, return air temperature, relative humidity%, air exchange m³/hour, USDA 1 +2 + 3 temperatures and cargo temperature.

When entering the menu, the newest logged temperatures are always shown.

Press  to toggle between stored set of temperatures: Setpoint temperature + supply air temperature, return air temperature, relative humidity%, air exchange and the other set of temperatures: USDA 1 +2 + 3 temperatures and cargo temperature.

To move one page up, press , or down, press , to list the previous or next page of stored set of values from the data log.

L03 Viewing log of temperatures (Graph)

Function:

Viewing of logged temperatures. Press  on the main menu to get directly to this menu.



Value:

The following data can be viewed: Setpoint temperature, supply air temperature, return air temperature, USDA 1 +2 + 3 temperatures and cargo temperature.

When entering the menu, the newest logged temperatures are always shown.

The number under the text **Ref** shows the temperature at the ◀ mark, ex. 5°C.

Press  to toggle between stored set of temperatures: Setpoint temperature + supply air temperature, return air temperature and the other set of temperatures: USDA 1 + 2 + 3 temperatures and cargo temperature.

Press up  or down  to show newer or older stored set of values from the data log.

Press  to change between the 4 zooming levels. The blank and black "bar" at the right-most edge shows a scale of 1°C per Bar.



Time adjust:

C01 Setting of year (GMT-Year)

Function:

Setting of year.

Value:

Set from 1999 to 2099.

C02 Setting of month (GMT-Month)

Function:

Setting of month.

Value:

Set from 1 to 12.

C03 Setting of day (GMT-Day)

Function:

Setting of day.

Value:

Set from 1 to 31.

C04 Setting of hours (GMT-Hour)

Function:

Setting of hours.

Value:

Set from 0 to 23.

C05 Setting of min. (GMT-Minute)

Function:

Setting of min. Note: when min. are set, sec. are set to 00.

Value:

Set from 0 to 59.

Run time counters:

R01 Viewing of operation hours for the Star Cool unit (Unit)

Function:

Viewing of Star Cool unit operation hours.

Value:

Shown as hours.

R02 Viewing of compressor operation hours (Compressor)

Function:

Viewing of compressor operation hours.

Value:

Shown as hours.

R03 Viewing of evaporator fan operation hours (Evaporator fan)

Function:

Viewing of evaporator fan operation hours.

Value:

Shown as hours.

R04 Viewing of condenser fan operation hours (Condenser fan)

Function:

Viewing of condenser fan operation hours.

Value:

Shown as hours.



R05 Viewing of heater operation hours (Evaporator heater)

Function:

Viewing of heater operation hours.

Value:

Shown as hours.

R06 AirEx motor sw times

Function:

Total run time

Value:

Hours

Configuration:

F01 Container ID viewing (Container)

Function:

Viewing of container ID.

Value:

Shown in the lower display line. E.g. MCID 000 001 2

F02 Software version viewing (Software version)

Function:

Viewing of software version and revision

Value:

-

F03 Compressor FC type setting (FC type)

Function:

Setting of actual FC type.

Value:

Setting as DANFOSS for Danfoss VLT® and NONE for no FC mounted ("Emergency Operation" p. 51, for specific information).

F04 Compressor frequency converter ID (FC ID)

Function:

Viewing of ID for FC for compressor.

Value:

-

F05 Setting of phase direction (Phase direction)

Function:

Setting of phase direction.

Value:

Is only possible when AL423 is active.

Default setting is Auto for automatic phase detection – automatically selected when the unit has been switched off for more than 30 min. before switching it on again.

Can be used for manual phase setting: Setting as CW for clockwise rotation or CCW for counter-clockwise rotation.

If manual phase direction is set, heat is reduced to 60% of max.

F06 Calibration of AirExchange sensor (AirEx calibration)

Function:

Zero adjust of AirExchange sensor when the air inlet is closed

Value:

Actual value of sensor is set to zero when enter key, , is pressed.



F07 Type of low pressure transmitter (Low pres type)

Function:

Set the pressure transmitter that is physically mounted for low pressure measurement. Press Enter for 3 sec. to make the selection.

Value:

AKS for Danfoss pressure transmitter, NSK for SAGInoMIYA pressure transmitter.

F08 Type of high pressure transmitter (High pres type)

Function:

Set the pressure transmitter that is physically mounted for high pressure measurement. Press Enter for 3 sec. to make the selection.

Value:

AKS for Danfoss pressure transmitter, NSK for SAGInoMIYA pressure transmitter.

F09 Serial number of controller board (Main PCB)

Function:

Shows the serial number of the controller board

Value:

-

F10 Model code

Function:

Model

Value:

-

F11 Freshair type

Function:

Type

Value:

35 CMH or 75 CMH

Serial Numbers

N01 SMC

Function:

Main controller

Value:

Main controller serial no.

N02 SUP

Function:

User panel

Value:

User panel serial no.

N03 SPM

Function:

Power meas

Value:

Power meas serial no.

N04 RH

Function:

Humidity sensor

Value:

Humidity sensor serial no.

**N05 O2****Function:**

O2 sensor

Value:

O2 sensor serial no.

N06 CO2**Function:**

CO2 sensor

Value:

CO2 sensor serial no.

N07 SSC**Function:**

Sub controller

Value:

Sub controller serial no.



N08 FCCP**Function:**

Frequency converter

Value:

Frequency converter serial no.

°C and °F Temperature Scale Showing, Alternately

While button  is pressed, °F is shown instead of °C and Psi is shown instead of Bar. If software is default °F/Psi, then °C and Bar is shown instead while  is pressed.

Permanently change to °F/Psi is available with the use of StarView.

Permanently change to °C/Bar for machines initially set to °F/Psi is also possible with StarView.

Though a power cycle will reset this back to °F/Psi.



Shown pressure is relative to atmosphere pressure.

Viewing graph of Supply and Return Temperature

Press  to enter graphical view (this function is a shortcut to L03 ("Datalog view:" p. 46)).



To return to main page press  two times.



Press  to toggle between stored set of temperatures: Setpoint temperature + supply air temperature, return air temperature and the other set of temperatures: USDA 1 + 2 + 3 temperatures and cargo temperature.

Press up  or  down, , to show newer or older stored set of values from the data log.

Manual Defrost Initiation

A manual defrost is only accepted if Tevap less than (<) 15°C (59°F)

Defrosting is manually initiated by pressing the  key and holding it for 3 sec. The display shows the  icon as an acceptance of defrost initiation.

A automatically or manually initiated defrosting may be terminated by pressing  and holding it for 3 sec. The display will cancel the  icon.





Water-cooling Activation/Deactivation

The following only applies for with water cooling (WC)

Water-cooling connecting is executed as follows:

- The container must be connected to the water-cooling system.
- Press  and hold it for 3 sec. The display shows the icon as an acceptance of water-cooling operation. The condenser fan is deactivated.

Water-cooling turn-off is executed as follows:

- Press  and hold it for 3 sec. The display turns off the  icon as an acceptance of non-operating water-cooling. The condenser fan turns on automatically.
- The container can be disconnected from the water-cooling system.

If the water supply is insufficient (the water hose is jammed, the water is not running or the water temperature is too high), the temperature in the condenser will rise and cooling capacity is decreasing and thereby threatening the cargo.

If the condenser temperature rises above 58°C (136°F), the system will automatically switch to air-cooling of condenser by turning the condenser fan on. If the water flow is restored, the controller stops air-cooling of the condenser.

If the temperature stays at the high temperature for more than 1 hour, an alarm is given.

The actual setting of water-cooling is remembered if the unit is switched off or there should be a power loss. Water-cooling is only turned off when the set point temperature is changed or when water-cooling is turned off manually.

Emergency Operation



Warning: High Voltage. Unit must be disconnected from power. Only to be done by trained personnel.

FC defective

If FC is defect and no replacement part is available, compressor may be run in the on / off mode. Defect FC is dismantled and the 3 phases are directly applied to the compressor supply terminals. Also a wire-jumper has to be fitted on the remaining 3 terminals, see below figure.

In the configuration menu, **F03 FC TYPE**, the parameter **NONE** is selected. Unit will then run in the on / off mode with deteriorated temperature controlling performance.

The connection for the FC is shown on below drawings:

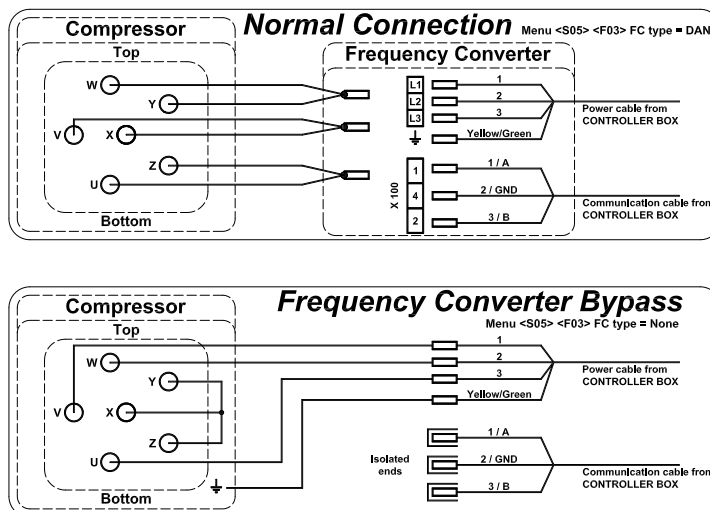



Controller defective

If the controller of the unit is malfunctioning or defective and no replacement is available, the unit can be run in a emergency mode with deteriorated temperature controlling performance. This operation is only recommended for cargo being transported in frozen mode, setpoint below -10°C (14°F). If the cargo is transported in chilled mode, it is recommended that the defective controller is replaced with one from a unit operating in frozen mode.

The emergency procedure for a unit with a defective controller, running in frozen mode, is as follows:

1. Dismount the frequency converter and connect the compressor directly to the power supply. Use the contactor in the controller as a main switch for the compressor.
2. Connect the evaporator fans in low speed and the condenser fan in high speed directly to the power supply.
3. Mount permanent magnet on the electrical expansion valve, pos. 18 (P & I diagram).
4. Install a service gauge manifold on the unit to the two evacuation points, pos. 6 & 27 (P & I - diagram).
5. Close the stop valve pos. 14 (P & I - diagram).
6. Energize the fans and the compressor.
7. Carefully open the stopvalve pos. 14 (P & I - diagram), observing the pressure readings on the service gauge manifold as this is done.
8. For a setpoint temperature of -20°C ($-4,0^{\circ}\text{F}$) a suction pressure of -24°C ($-11,2^{\circ}\text{F}$) is to be maintained. In general the suction pressure (temperature) is to be 5°C (7°F) below the set point temperature. In general the discharge pressure (temperature) is to be 10°C (18°F) above ambient temperature.
9. If there is ice building up on the compressor, it indicates that there is coming to much liquid back from the evaporator. Close the stopvalve pos. 14 (P & I - diagram) slightly.

External interfaces

The Star Cool controller can be accessed externally in the following ways:

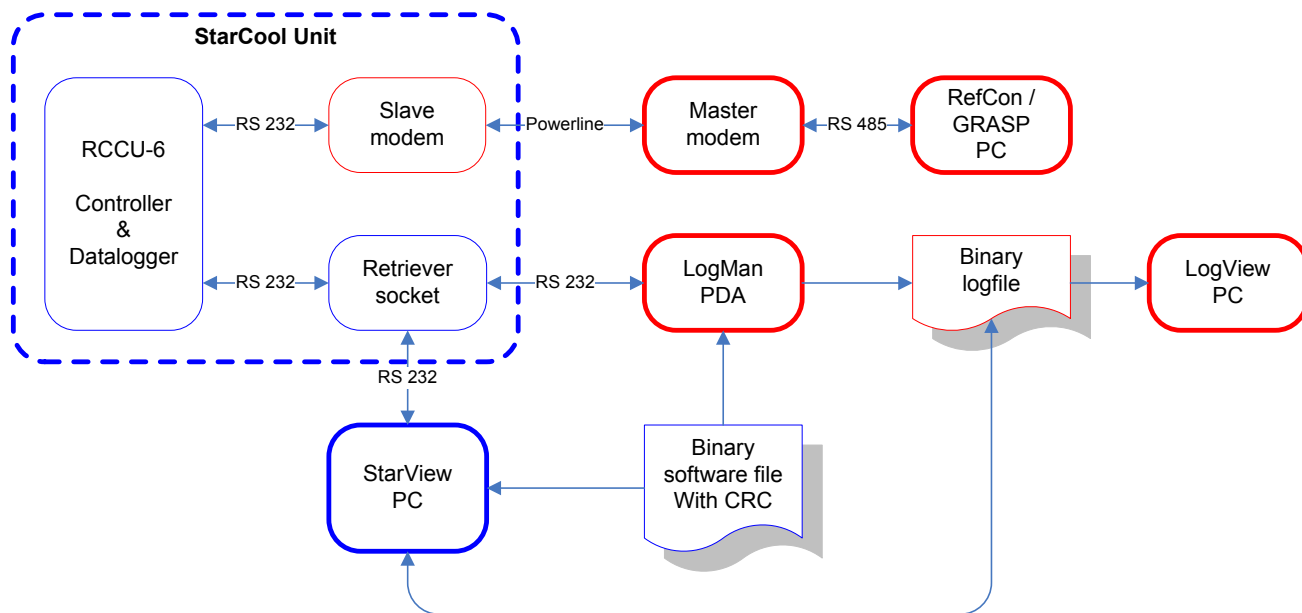

General requirements

1. Serial port setup is 19200, 8, N, 1
2. Unless otherwise stated, byte order is low byte first



List of terms used for external interfaces

Term	Description
LM	Local Monitor serial communication port on the container unit
LogMan	Hand held datalog retriever terminals
LogView	PC software viewer for container datalog files
SCCU6	Reefer Container Controller Unit (Star Control)
RefCon	Powerline based container monitoring system and PC software
RMM	Remote Monitor Modem for power line communication
Star Cool	Reefer container unit name
StarView	PC software Star Cool unit monitor

Functions overview

It is defined in the table below, which Star Cool functions each device and system will support.

Function	LogMan	LogView	RefCon	StarView	Controller
Display basic data ¹			x	x	x
Display alarm list			x	x	x
Display controller information			x	x	(x)
Change container ID	x		x	x	
Change temperature setpoint			x		x
Change humidity setpoint			x		x
Change controller date and time	x		x		x
Change units from °C/Bar to °F/Psi				x	
Calibrate USDA and Cargo sensors	x			x	x
Acknowledge alarms				x	x
Initiate manual defrost			x		
Initiate Trip Start	x		x		
Initiate Function- and PTI test			x	x	x
Terminate Function- and PTI test			x	x	x
Display Function- and PTI test results			x	x	x
Retrieve datalog from unit	x		x	x	
Save datalog file (binary)	x			x	
Save datalog file (RefCon)			x		
Save datalog file (CSV text)				x	
Display datalog file (binary)		x		x	
Display datalog file (RefCon)			x		
Display datalog file (CSV text)				x	
Erase datalog memory					
Update controller software via bootloader	x				
Update controller software via protocol				x	
Operate controller in manual mode					x

(1) Basic data: Tset, Tsup, Tret, RH,Tusda1..3, Tcargo, Operation mode, Ubat

(x) Not all information is visible on the controllers display.



Location of valves

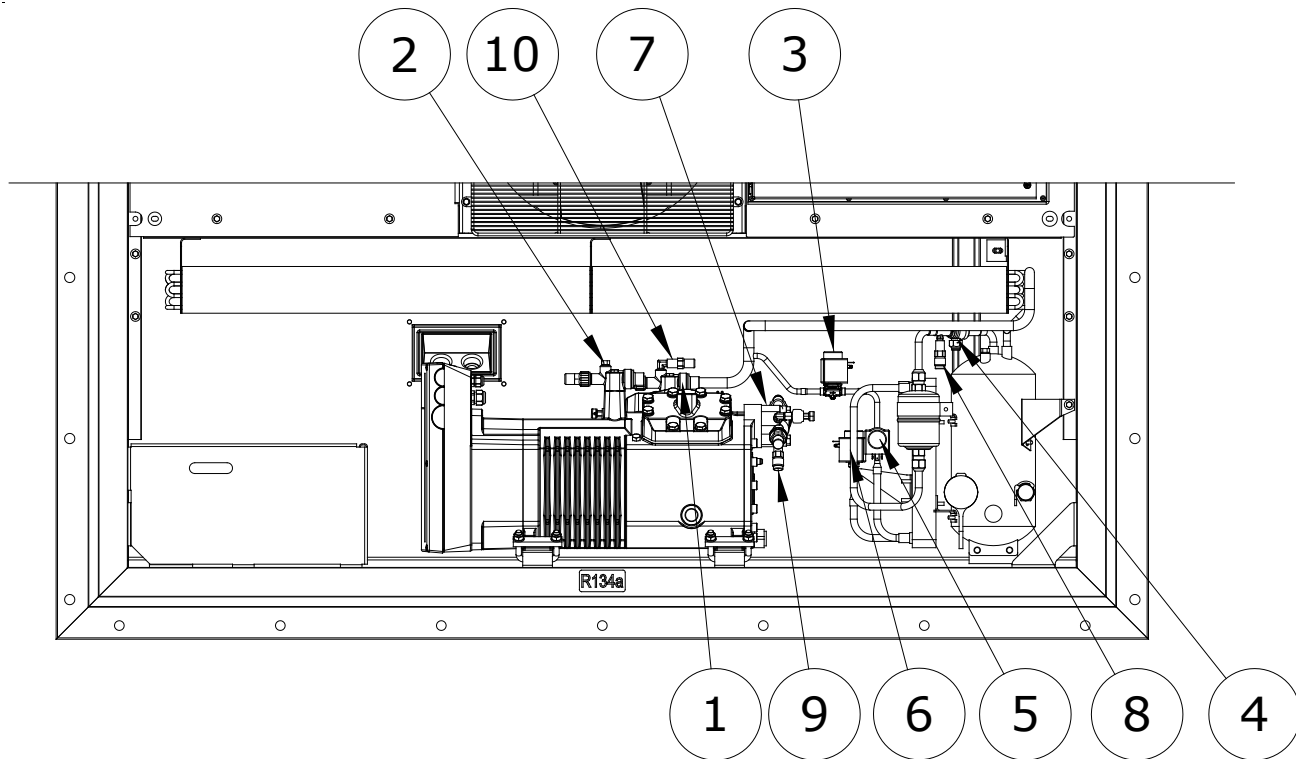

Position	Description
1	Discharge service valve
2	Economizer suction service valve
3	Hot gas valve
4	Service valve, economizer
5	Electronical expansion valve, evaporator
6	Electronical expansion valve, economizer
7	Suction service valve
8	Liquid charging valve
9	Evacuation valve
10	Evacuation valve



Location of motors, temperature sensors, humidity sensor and air exchange potentiometer

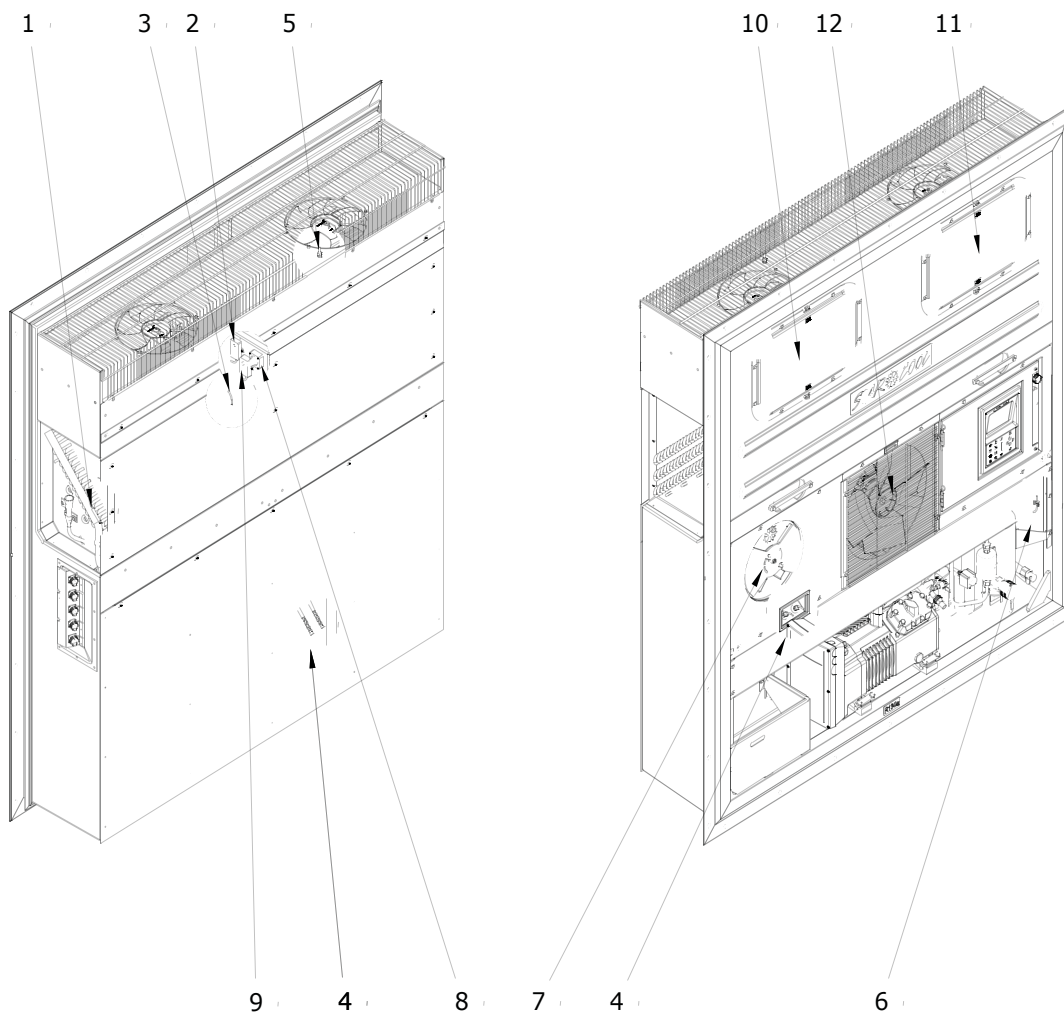

Pos	Description	Short name	Number	Location	Accessibility
1	Suction temperature sensor	Tsuc	1	Inside	Through inspection hatch
2	Relative humidity sensor	RH	1	Inside	Through inspection hatch
3	Evaporator temperature sensor	Tevap	1	Inside	Through inspection hatch
4	Supply temperature sensor	Tsup	2	Outside	
5	Return temperature sensor	Tret	1	Inside	Through inspection hatch
6	Ambient temperature sensor	Tamb	1	Outside	
7	Air Exchange potentiometer	AirEx	1	Outside	Behind fresh air cover panel
8*	Carbon dioxide sensor	CO2	1	Inside	Through inspection hatch
9*	Oxygen sensor	O2	1	Inside	Through inspection hatch
10	Evaporator motor no. 1	Mevap1	1	Inside	Through inspection hatch
11	Evaporator motor no. 2	Mevap2	1	Inside	Through inspection hatch
12	Condenser motor	Mcond	1	Inside	Through fan grill

*) Optional



Location of pressure transmitters, high pressure switch and oil outlet port

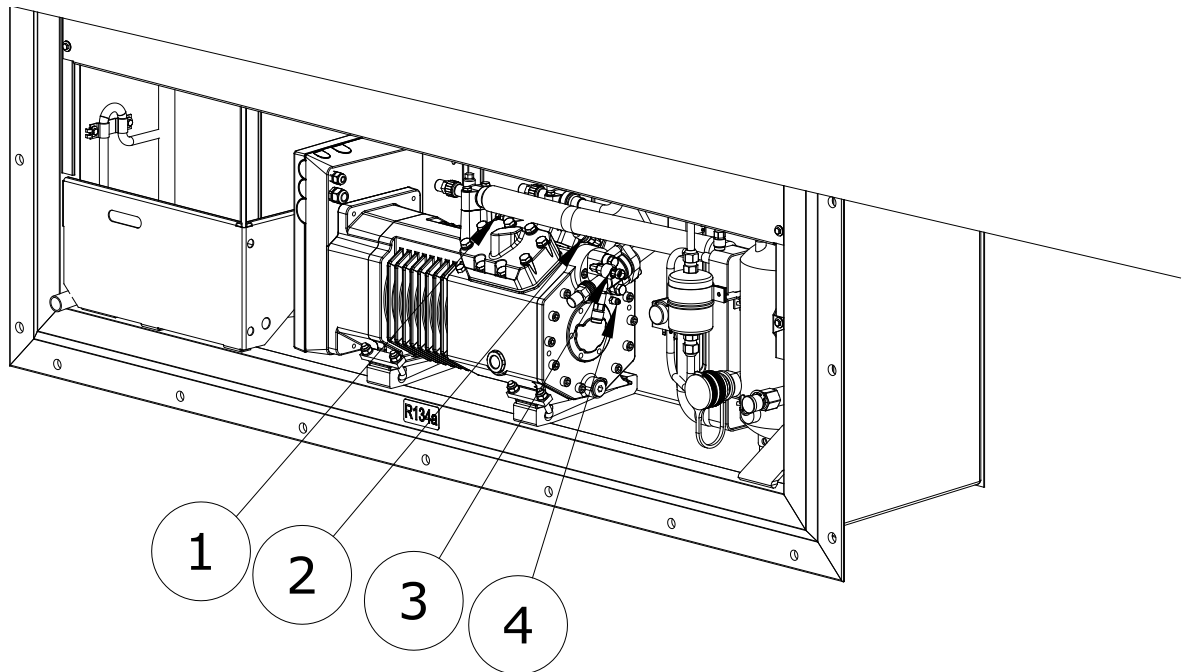



Pos	Description	Short name	Number	Location
1	Discharge Pressure transmitter	Pdis	1	Outside
2	High pressure switch	Shp	1	Outside
3	Suction Pressure transmitter	Psuc	1	Outside
4	Oil outlet port		1	Outside

General trouble shooting

Hints for general trouble shooting.

- Unit will not start up.
Check that power is applied to the unit.
Check that fuses at QS1, F1 and or F2 are not blown.
Check alarm list and clear alarms and alarm causes.

The unit is wired for emergency operation but the parameter F03 FC type under service menu,  is not set to NONE.

The menu F03 under service menu,  is set to NONE for emergency operation but the wires have not been correctly mounted for emergency operation.

- Unit starts but stops shortly after.
Check that the condenser motor is rotating and that the air is blowing away from the unit.
Check if the high pressure switch alarm is active in the alarm list.
Temperature sensors not working properly. Check that they are placed on the pipes and are inside the isolation.
- Unit is running but is not bringing the temperature down to temperature setpoint.
The cargo is very warm – it takes a long time to cool it down.
The ambient temperature is very high – the condenser can only cool a little so the cooling capacity is small and the cool down process takes longer time.



The hot gas valve may be leaking so that the hot gas is by-passing the condenser and is pumped into the evaporator and heating it up.
 The expansion valve is not opening and no cooling refrigerant is pumped into the evaporator.
 The condenser pressure will be very high.
 The unit has been put in manual phase detecting mode and all motors are running the wrong way. The compressor will pump correctly but there is very little cooling capacity in the condenser and the air flow is wrong inside in the box.
 One of the motors (condenser or evaporator) is running in the opposite direction.

4. Liquid refrigerant is entering the compressor through the evaporator.
 The temperature sensor, Tsuc is not working properly. Check that the sensor is mounted close to the pipe and is placed beneath the isolation.
 The pressure transmitter, Psuc is not working properly.
 The evaporator sensor, Tevap is not working properly.
5. Display is blank.
 Adjust contrast ("Contrast adjustment of the display" p. 32)

Trouble shooting for Star Cool main controller

A method to check if the controller is performing correct readings.

If there is a problem with a sensor or a transmitter, the X22, X23, X24 and X25 cable on the main controller must be disconnected to see if the defective is with the sensor/transmitter or the main controller. The procedure is:

1. Set unit to "Manual Operation Mode" by choosing "Service Menu" and "Operation Mode" and changing "Auto" to "Manual".
2. Disconnect the X22, X23, X24 and X25 cable from the main controller.
3. After a while enter the "Information Menu". In here the following values shall appear:
 - a. Temperature drops to -70°C
 - b. Psuc shows: -1.0 BarE
 - c. Pdis shows: 0.0 BarE
 - d. AirEx must read: 0 m3
 - e. Humidity: 0%
4. If one of these listed values does not appear, the main controller must be replaced.

Detailed alarm description

In the following all alarms are listed with a description and their causes.

- Alarm text is the text shown in the controller display.
- A cross to the right of Log indicates that the alarm is logged into the data log.
- A cross to the right of alarm indicates that error is shown in the controller alarm list.
- To the right of **Light** the following texts can be shown:
 - Off** indicates that the alarm diodes are de-energized and there are **no active** alarms,
 - Slow flash** indicates that the diodes are turned on shortly every 3 sec. and that there are **active alarm(s)**,
 - Quick flash** that the diodes are turned on 0.8 sec. every 1 sec. and that there is an **active fatal alarm(s)**.

When troubleshooting several alarms, it is generally advisable to start with the active alarm that has the lowest number and then go on to the active alarms with higher numbers. Remember that some alarms have a time out of 30 sec. and more.



Alarm list

The following list includes a view of all alarms as listed on the display and a longer text. This list is subject to constant updates - be sure to visit www.mcicontainers.com/Service/Pages/alarmlists.aspx for latest update

Id	Display text	Description	Alarm type
1. Temperature sensor alarms			
100	Tret open	Return Air Temperature Sensor Open Circuit	Warning
101	Tret short	Return Air Temperature Sensor Short Circuit	Warning
102	Tret invalid	Return Air Temperature Sensor Invalid	Warning
103	Tsup 1 open	Supply Air Temperature Sensor 1 Open Circuit	Warning
104	Tsup 1 short	Supply Air Temperature Sensor 1 Short Circuit	Warning
105	Tsup 1 invalid	Supply Air Temperature Sensor 1 Invalid	Alarm
106	Tsup 2 open	Supply Air Temperature Sensor 2 Open Circuit	Warning
107	Tsup 2 short	Supply Air Temperature Sensor 2 Short Circuit	Warning
108	Tsup 2 invalid	Supply Air Temperature Sensor 2 Invalid	Alarm
109	Tusda 1 open	USDA 1 Temperature Sensor Open Circuit	Warning
110	Tusda 1 short	USDA 1 Temperature Sensor Short Circuit	Warning
111	Tusda 1 invalid	USDA 1 Temperature Sensor Invalid	Log
112	Tusda 2 open	USDA 2 Temperature Sensor Open Circuit	Warning
113	Tusda 2 short	USDA 2 Temperature Sensor Short Circuit	Warning
114	Tusda 2 invalid	USDA 2 Temperature Sensor Invalid	Log
115	Tusda 3 open	USDA 3 Temperature Sensor Open Circuit	Warning
116	Tusda 3 short	USDA 3 Temperature Sensor Short Circuit	Warning
117	Tusda 3 invalid	USDA 2 Temperature Sensor Invalid	Log
118	Tcargo open	Cargo Temperature Sensor Open Circuit	Warning
119	Tcargo short	Cargo Temperature Sensor Short Circuit	Warning
120	Tcargo invalid	Cargo Temperature Sensor Invalid	Log
121	Tevap open	Evaporator Temperature Sensor Open Circuit	Warning
122	Tevap short	Evaporator Temperature Sensor Short Circuit	Warning
123	Tevap invalid	Evaporator Temperature Sensor Invalid	Warning
124	Tsuc open	Suction Temperature Sensor Open Circuit	Warning
125	Tsuc short	Suction Temperature Sensor Short Circuit	Warning
126	Tsuc invalid	Suction Temperature Sensor Invalid	Warning
127	Tamb open	Ambient Temperature Sensor Open Circuit	Warning
128	Tamb short	Ambient Temperature Sensor Short Circuit	Warning
129	Tamb invalid	Ambient Temperature Sensor Invalid	Warning
2. Pressure transmitter alarms			
200	Pdis open	Compressor Discharge Pressure Transmitter Open Circuit	Warning
201	Pdis short	Compressor Discharge Pressure Transmitter Short Circuit	Warning
202	Pdis fault	Compressor Discharge Pressure Transmitter Open or Short Circuit	Warning
203	Pdis invalid	Compressor Discharge Pressure Transmitter Invalid	Warning
204	Psuc open	Compressor Suction Pressure Transmitter Open Circuit	Warning
205	Psuc short	Compressor Suction Pressure Transmitter Short Circuit	Warning



206	Psuc fault	Indication of loose connection, short-circuited, defective or complete lack of compressor suction pressure transmitter.	Warning
207	Psuc invalid	Compressor Suction Pressure Transmitter Invalid	Warning
250	Press sensor type	Wrong Suction Pressure Transmitter	Alarm
3. Other sensors			
302	RH invalid	Relative Humidity Sensor Invalid	Warning
303	AirEx No connection	Air Exchange Sensor Short Circuit	Warning
304	AirEx short	Air Exchange Sensor Short Circuit <i>Not implemented yet</i>	Warning
305	AirEx invalid	Air Exchange Sensor Invalid. <i>Not implemented yet</i>	Warning
306	High press switch	High pressure switch is active	Warning
314	Replace CO2 sensor	Replace CO2 sensor	Alarm
315	Replace O2 sensor	Replace O2 sensor	Alarm
316	Replace CO2 sensor	Replace CO2 sensor	Warning
317	Replace O2 sensor	Replace O2 sensor	Warning
4. Power alarms			
400	Mevap 1 over heat	Evaporator Motor 1 overheat	Warning
401	Mevap 2 over heat	Evaporator Motor 2 overheat	Warning
402	Mcond over heat	Condenser Motor overheat	Warning
410	Unstable supply	Power supply unstable	Fatal Alarm
411	Unit over current	Unit overcurrent	Log
414	U1-2 over voltage	U1-2 overvoltage	Fatal Alarm
415	U2-3 over voltage	U2-3 overvoltage	Fatal Alarm
416	U1-3 over voltage	U1-3 overvoltage	Fatal Alarm
417	U1-2 under voltage	U1-2 undervoltage	Fatal Alarm
418	U2-3 under voltage	U2-3 undervoltage	Fatal Alarm
419	U1-3 under voltage	U1-3 undervoltage	Fatal Alarm
420	I1 over current	I1 overcurrent	Log
421	I2 over current	I2 overcurrent	Log
422	I3 over current	I3 overcurrent	Log
423	No phase direction	Phase Direction Not Detectable	Fatal alarm
424	Power frequency	Phase Frequency Error	Log
425	Frequency too high	Power Frequency too high	Warning
426	Frequency too high	Power Frequency too high	Alarm
427	U/f ratio low	Bad power supply - over loaded / under supplied	Alarm
428	U/f ratio high	Bad power supply - voltage regulation out of order	Alarm
429	U/f ratio	Bad power supply	Fatal alarm
430	Cpr connection	Power Cable From FC to Compressor Faulty	Alarm
5. FC alarms			
501	FC local control	FC Local Mode Fault	Alarm
508	FC short circ	FC Short Circuit Fault Alarm	Alarm
509	FC 24 V fault	FC Internal 24 V Supply Fault Alarm	Alarm
510	FC earth fault	FC Earth Fault Alarm	Alarm
511	FC over cur	FC Overcurrent Fault Alarm	Alarm



512	FC motor therm	FC Compressor Motor Over temperature	Alarm
513	FC overload	FC Overload Fault Alarm	Alarm
514	FC under volt	FC Voltage Low Fault Alarm	Alarm
515	FC over volt	FC Voltage High Fault Alarm	Alarm
516	FC phase loss	FC Phase Loss Fault Alarm	Alarm
517	FC over temp	FC Over temperature Fault Alarm	Alarm
518	FC inrush	FC Inrush Fault Alarm	Alarm
519	FC internal	FC Internal Error Fault Alarm	Alarm
521	FC high volt	FC High Voltage Fault Warning	Warning
522	FC high temp	FC Over temperature Fault Warning	Log
523	FC phase loss	FC Phase Loss Fault Warning	Warning
524	FC current limit	FC Current Limit Fault Warning	Warning
525	FC overload	FC Overload Fault Warning	Warning
529	FC setup error	FC Setup Fault Warning	Warning
566	FC undefined alarm	FC Undefined Alarm	Warning
599	FC Trip Lock	FC has tripped and stopped	Log
6. Operation alarms			
600	No control sensors	Supply Air Sensor 1, Supply Air Sensor 2, Return Air Sensor All Malfunctioning	Fatal Alarm
601	No watercooling	Water-cooling fault	Warning
602	Tset unreachable	Tset Unreachable. <i>Not implemented yet</i>	Alarm
603	In range fault	In-range Fault	Fatal Alarm
604	High press trouble	High Pressure Safety Switch is active	Fatal Alarm
607	AirEx open	Air exchange valve open in conflict with settings	Fatal Alarm
608	Select AirEx Type	AirEx type missing	Warning
609	Defrost Trouble	Defrost is running	Warning
610	Defrost time exceed	Max. defrost time exceeded	Warning
611	Too many sensor err	Too many (controlling) sensors have errors	Alarm
612	FC trouble	There have been several FC alarms within short time	Alarm
613	Motor trouble	Evaporator Motor 1 or 2 Overheated several times or permanently within short time	Alarm
614	Humidity deactivated	Humidity control deactivated	Alarm
615	Mcond trouble	Condenser fan motor overheated several times	Alarm
616	Mevap trouble	Evaporator fan motor overheated several times	Alarm
620	Cpr start failed	Not implemented yet	Fatal Alarm
621	Cpr restarted	The Compressor Has Been Restarted	Warning
622	Loss of cooling	Attempts to cool down but Tsup is above Tret	Warning
623	Loss of cooling	Attempts to cool down but Tsup is above Tret	Fatal Alarm
625	CT outrange	Cold Treatment out of range	Alarm
630	Manual phase dir	Manually Selected Phase Direction	Warning
631	Fuse blown	Blown Fuse	Warning
632	Phase Missing	Phase missing	Fatal Alarm
7. Communication alarms			
700	FC missing	FC missing	Fatal Alarm



710	Display missing	(Can only be seen in Star View)	Warning
711	Display com	Reduced communication with display	Warning
720	Power module missing	Communication to power module is missing	Alarm
721	Power module com	Communication to power module missing	Warning
730	RH sensor missing	RH sensor is missing	Alarm
8. Test alarms			
800	Func test failed	Function Test Fault	Alarm
801	Controller	Controller Internal Voltage Reference Fault	Alarm
805	Idle current	Unit Idle Overcurrent Fault	Alarm
810	Mevap cur LO speed	Evaporator Motor Low Speed Current Fault	Alarm
811	Mevap cur HI speed	Evaporator Motor High Speed Current Fault	Alarm
812	Mevap current OFF	Evaporator Motor Off Current Fault	Alarm
813	Mevap direction	<i>Not implemented yet</i>	Alarm
815	Mcond cur LO speed	Condenser Motor Low Speed Current Fault	Alarm
816	Mcond cur HI speed	Condenser Motor High Speed Current Fault	Alarm
817	Mcond current OFF	Condenser Motor Off Current Fault	Alarm
820	Hevap current ON	Evaporator Heater On Current Fault	Alarm
821	Hevap current OFF	Evaporator Heater Off Current Fault	Alarm
840	Valve leaks	Valve Leak Fault	Alarm
842	Expansion valve	Expansion Valve Fault	Alarm
843	Economizer valve	Economizer Valve Fault	Alarm
844	Hot gas valve	Hot gas Valve Fault	Alarm
845	Cpr pump down	Compressor pump down fault	Alarm
846	FC check	FC internal fault	Alarm
850	PTI test failed	PTI Test Fault	Alarm
855	PTI Tset 5	PTI 5°C Set Fault	Alarm
860	PTI Tset 0	PTI 0°C Set Fault	Alarm
870	PTI defrost	PTI Defrost Fault	Alarm
880	PTI Tset -18	PTI -18°C Set Fault	Alarm
9. Controller alarms			
900	User stop	User stop was executed from PC-program	Fatal Alarm
902	Battery malfunction	Battery Malfunctioning	Alarm
904	Datalog error	SCCU6 Data log Fault	Alarm
905	Database corrupt	SCCU6 Database Fault	Log
906	Invalid date/time	Date and time not valid	Log
907	Realtime error	Real-time Clock Unreliable	Alarm
908	Realtime invalid	Real-time Clock Unavailable	Log
910	Main power failure	Main Power Fault	Log
911	Battery voltage LO	Low Battery Voltage	Warning
912	Battery voltage HI	High Battery Voltage	Log
953	Temp ref 1 LO	Controller Internal Voltage Reference Fault	Warning
954	Temp ref 1 HI	Controller Internal Voltage Reference Fault	Warning



955	Temp ref 2 LO	Controller Internal Voltage Reference Fault	Warning
956	Temp ref 2 HI	Controller Internal Voltage Reference Fault	Warning
961	Pdis sens sup LO	Controller Internal Voltage Reference Fault	Warning
962	Pdis sens sup HI	Controller Internal Voltage Reference Fault	Warning
963	Psuc sens sup LO	Controller Internal Voltage Reference Fault	Warning
964	Psuc sens sup HI	Controller Internal Voltage Reference Fault	Warning
965	Controller sup LO	Controller Internal Voltage Reference Fault	Warning
966	Controller sup HI	Controller Internal Voltage Reference Fault	Warning
967	AirExMot sup LO	Controller Internal Voltage Reference Fault	Warning
968	AirExMot sup HI	Controller Internal Voltage Reference Fault	Warning
969	AirEx sens sup LO	Controller Internal Voltage Reference Fault	Warning
970	AirEx sens sup HI	Controller Internal Voltage Reference Fault	Warning
971	Sensor bus sup LO	Controller Internal Voltage Reference Fault	Warning
972	Sensor bus sup HI	Controller Internal Voltage Reference Fault	Warning
973	SUP6 SPM6 sup LO	Supply voltage SUP6 SPM6 low	Warning
974	SUP6 SPM6 sup HI	Supply voltage SUP6 SPM6 HI	Warning
975	Internal sup LO	12 V supply voltage low on SMC6	Warning
976	Internal sup HI	12 V supply voltage high on SMC6	Warning
980	Tinternal LO	Controller Internal Voltage Reference Fault	Warning
981	Tinternal HI	Controller Internal Voltage Reference Fault	Warning
988	Powermeas cali-brat	Powermeas calibration not possible	Warning
989	Software test ver	Software test version	Warning
990	Firmware update fail	Failed to activate firmware	Alarm
991	Select model code	Model code missing	Warning
995	Replace ctrl. module	Controller module must be replaced	Fatal Alarm
996	Software CRC error	Prom CRC Fault	Alarm
999	Keyboard failure	Indication of defective keyboard	Warning

Events

No.	Name	Parameter explanation				
		No. 1	No. 2	No. 3	No. 4	No. 5
0	Temperature set-point	Old set-point	New set-point	-	-	SW revision
1	Humidity set-point	Old set-point	New set-point	-	-	-
2	Watercool deselect	-	-	-	-	-
3	Watercool select	-	-	-	-	-
4	FT start	Version	-	-	-	Alarms count
5	FT step OK	Step ID	-	-	-	-
6	FT abort	Step ID	-	-	time (sec)	Alarms count
7	-	-	-	-	-	-
8	PTI start	PTI Version	1: Full PTI 2: Short PTI 3: CA PTI	-	-	Alarms count
9	PTI step OK	PTI test ID	-	-	-	-



10	PTI abort	PTI test ID	-	-	time (sec)	Alarms count
11	-	-	-	-	-	-
12	Manual mode select	-	-	-	-	-
13	Manual mode deselect	-	-	-	-	-
14	Defrost Start	1: Manual start 2: Ice counter 3: Demand defrost start	0 Not demand 1 Tevap 2 Abnormal 3 Tsuc 4 Tret	0: Hot gas 2: Elec.	Ice counter	-
15	Defrost Stop	Current defrost interval [sec]	Tevap	0: Hot gas 2: Elec.	-	-
16	Trip Start	1: Auto trip-start 0: User trip-start	SW ver. low	SW ver. high	-	SW rev.
17	Sensor Calibrated	1 = USDA 1 2 = USDA 2 3 = USDA 3 4 = CARGO	Old Cal. Value	New Cal. Value	-	-
20	Power Up	Unit run time [hours]	Compr. run time [hours]	Mevap run time [hours]	Mcond run time [hours]	Hevap run time [hours]
21	User Wake-up	-	-	-	-	-
22	Power Down	SW ver. low	SW ver. high	Vbatt.	Power up count	Reset count
23	Software update	Current sw ver low	Current sw ver high	New sw ver low	New sw ver high	-
25	Real time clock	Old date	Old time	New date	New time	-
26	FC type	Old	New	-	-	-
27	Datalog interval	Old	New	-	-	-
28	Defrost interval	Old [min] (*)	New [min] (*)	-	-	-
29	FC ID	Old ID	Old ID hibernate	New ID	New ID hibernate	
30	Container ID change	1st: Old	-	-	-	-
31	Press sensor type	Old LP	New LP	Old HP	New HP	-
32	Parameter change	Source	Parameter id / Telegram id	Old value	New value	n/a
40	Cold Treatment (CT) start	0: Normal	CT Duration [min.]	CT setpoint emp.	CT high limit	Final setpoint temp
41	CT period start	Actual temp.	Tusda1	Tusda2	Tusda3	Tcargo
42	CT Passed		Duration [min.]	CT setpoint temp.	CT high limit	Final setpoint temp.
43	CT ramp up	Tact	Tusda1	Tusda2	Tusda3	Tcargo
44	Multiple Temperature Set points (MTS) start	Step number	Step duration	Step setpoint	Step temp. chg./hour	Step humidity setpoint
45	MTS step stop	Step number	0: Normal 1: Aborted	Step setpoint	Step temp. chg./hour	Step humidity setpoint
47	CT Done	Number of valid USDA sensors	CT Duration [min.]	CT setpoint temp.	CT high temp. limit	Final setpoint temp.
48	CT Failed	0: Sensor error 1: Aborted	CT high temp. limit	Tusda1	Tusda2	Tusda3
60	QUEST mode	Old	New	n/a	n/a	n/a
61	QUEST2 start	Last event reason	New	n/a	n/a	n/a



62	QUEST2 stop	Last event reason	n/a	n/a	n/a	n/a
70**	Atm control start	O2 setpoint	CO2 Setpoint	Type: O2 or CO2	Pump runtime	Airex sw time
71**	Atm control stop	n/a	n/a	n/a	Pump runtime	n/a
72**	Atm setpoint	Old	New	Type: O2 or CO2	n/a	n/a
73	Module removed	1 = RH, 2 = O2, 3 = CO2, 4 = LOM, 5 = LPM, 6 = LUP	Old SN	Old SN	Old SN	Old SN
74	Module added	1 = RH, 2 = O2, 3 = CO2, 4 = LOM, 5 = LPM, 6 = LUP	New SN	New SN	New SN	New SN
75**	Calibration finished	2 = O2, 3 = CO2	0= Failed, 1= Passed	New O2 or CO2 measurement	Old O2 or CO2 measurement	Sign of old measurement (CO2 only)
76**	Calibration start denied	2 = O2, 3 = CO2	Sensor in session	O2 or CO2 measurement	Pmem	0
77	Controller moved	Number of changed SN's	Change bit-mask	0	0	0
90	Debug (intern. use)	1	Alarm count	Expected alarm count	-	-
92	Database updated	ErrorFlag	ErrorIndex	-	-	-

(*) The time is stored as minutes: 360 min = 6 * 60 min. = 6 hours

(**) Only for some models



Temperature Sensor Alarms (AL 1XX)

100	Tret open	Warning			
Description	Return Air Temperature Sensor Open Circuit				
Cause	Indication of loose connection, defective or lack of return air temperature sensor				
Trouble shooting	<p><u>Possible causes:</u></p> <ul style="list-style-type: none"> • Temperature sensor Tret or its cable defective. • X24 and X25 cable is defective. • Main controller defective. <p><u>Accompanied alarms:</u></p> <ul style="list-style-type: none"> • AL 102. <p><u>Trouble shooting:</u></p> <ol style="list-style-type: none"> 1) Disconnect the sensor cable for sensor Tret from the connector on the main controller, according to the wiring schematics inside in the control cabinet. 2) Measure the resistance between the two wires. <ol style="list-style-type: none"> a) If the resistance is more than 1.5 MΩ, the cable or the sensor is defective, replace sensor and cable. b) If the resistance matches the resistance and temperature in "Tables" p. 203, the temperature sensor and cable are OK. 3) Measure the voltage over the connector for Tret. It should be between 3.2 and 3.4 V DC <ol style="list-style-type: none"> a) If the voltage is inside the above range, connect sensor again. Measure the voltage over the sensor and check voltage/temperature according to "Tables" p. 203 b) If the voltage is outside the above range, the main controller is defective or other sensors may be defective and pulling the voltage down. Check other alarms and "Trouble shooting for Star Cool main controller" p. 57 before replacing main controller. 				
Criteria	Value below low alarm limit -60°C (-76°F)				
Controller action	Replaced by new value from AAS system				
	Log	X	Alarm	X	Alarm light
Consequence	Deteriorated control precision in the freeze mode				
Elimination	When sensor value becomes valid, it is marked as inactive in the alarm list and may then be deleted				
Log data	Parm 1	Parm 2	Parm 3	Parm 4	Parm 5
	Active/Inactive	Low limit	High limit	Present	



101	Tret short					Warning
Description	Return Air Temperature Sensor Short Circuit					
Cause	Indication of short-circuited return air temperature sensor					
Trouble shooting	<p><u>Possible causes:</u></p> <ul style="list-style-type: none"> • Temperature sensor Tret or its cable defective. • X24 and X25 cable is defective. • Main controller defective. <p><u>Accompanied alarms:</u></p> <ul style="list-style-type: none"> • AL 102. <p><u>Trouble shooting:</u></p> <ol style="list-style-type: none"> 1) Disconnect the sensor cable for sensor Tret from the connector on the main controller, according to the wiring schematics inside in the control cabinet. 2) Measure the resistance between the two wires. <ol style="list-style-type: none"> a) If the resistance is less than (<) 230 Ω, the cable or the sensor is defective, replace sensor cable. b) If the resistance matches the resistance and temperature in "Tables" p. 203), the temperature sensor and cable are OK. 3) Measure the voltage over the connector for Tret, it should be between 3.2 and 3.4 V DC <ol style="list-style-type: none"> a) If the voltage is inside the above range, connect sensor again. Measure the voltage over the sensor and check voltage/temperature ("Tables" p. 203) b) If the voltage is outside the above range, the main controller is defective or other sensors may be defective and pulling the voltage down. Check other alarms and "Trouble shooting for Star Cool main controller" p. 57 before replacing main controller. 					
Criteria	Value above high alarm limit +140°C (+284°F).					
Controller action	Replaced by new value from AAS system					
	Log	X	Alarm	X	Alarm light	Off
Consequence	Deteriorated control precision in the freeze mode					
Elimination	When sensor value becomes valid, it is marked as inactive in the alarm list and may then be deleted.					
Log data	Parm 1	Parm 2	Parm 3	Parm 4	Parm 5	
	Active/Inactive	Low limit	High limit	Present		



102	Tret invalid					Warning
Description	Return Air Temperature Sensor Invalid					
Cause	Indication of defective return air temperature sensor or its measuring circuitry					
Trouble shooting	<p><u>Possible causes:</u></p> <ul style="list-style-type: none"> Active alarms AL 100, AL 101 or AL 901 (if CIM5 software) Temperature sensor reading is out of valid range: -60°C (-76°F) or above +140°C (284°F). <p><u>Accompanied alarms:</u></p> <ul style="list-style-type: none"> AL 100 or AL 101 may also be active. <p><u>Trouble shooting:</u></p> <ol style="list-style-type: none"> If alarms AL 100 or AL 101 are active, check their trouble shooting section first. Disconnect the sensor cable for sensor Tret from the connector on the main controller, according to the wiring schematics inside in the control cabinet. If AL 901 is active, see trouble shooting for AL 901 Measure the resistance between the two wires. <ol style="list-style-type: none"> If the resistance is out of range of the resistance and temperature table, "Tables" p. 203, the temperature sensor and cable are defective and should be replaced. If the resistance is within range, perform main controller check "Trouble shooting for Star Cool main controller" p. 57 before replacing main controller. 					
Criteria	Sensor is defective and the missing sensor reading has been substituted by a value from AAS system. See "Alarm Action System (AAS)" p. 19					
Controller action	Replaced by new value from AAS system					
	Log	X	Alarm	X	Alarm light	Off
Consequence	Deteriorated control precision in the freeze mode					
Elimination	When sensor value becomes valid, it is marked as inactive in the alarm list and may then be deleted. Value must be valid for 60 sec. to set alarm inactive.					
Log data	Parm 1	Parm 2	Parm 3	Parm 4	Parm 5	
	Active/Inactive					



103	Tsup 1 open					Warning
Description	Supply Air Temperature Sensor 1 Open Circuit					
Cause	Indication of loose connection, defective or lack of supply air temperature sensor					
Trouble shooting	<p><u>Possible causes:</u></p> <ul style="list-style-type: none"> • Temperature sensor Tsup1 or its cable defective. • X24 and X25 cable is defective. • Main controller defective. <p><u>Accompanied alarms:</u></p> <ul style="list-style-type: none"> • AL 105. <p><u>Trouble shooting:</u></p> <p>1) Same trouble shooting is to be used for Tsup1 as used for Tret in AL100</p>					
Criteria	Value below low alarm limit -60°C (-76°F)					
Controller action	Replacement by new value from AAS system					
	Log	X	Alarm	X	Alarm light	Off
Consequence	Deteriorated control precision in the chill mode					
Elimination	When sensor value becomes valid, it is marked as inactive in the alarm list and may then be deleted.					
Log data	Parm 1	Parm 2	Parm 3	Parm 4	Parm 5	
	Active/Inactive	Low limit	High limit	Present		

104	Tsup 1 short					Warning
Description	Supply Air Temperature Sensor 1 Short Circuit					
Cause	Indication of short-circuited supply air temperature sensor					
Trouble shooting	<p><u>Possible causes:</u></p> <ul style="list-style-type: none"> • Temperature sensor Tsup1 or its cable defective. • X24 and X25 cable is defective. • Main controller defective. <p><u>Accompanied alarms:</u></p> <ul style="list-style-type: none"> • AL 105. <p><u>Trouble shooting:</u></p> <p>1) Same trouble shooting is to be used for Tsup1 as used for Tret in AL 101.</p>					
Criteria	Value above high alarm limit +140°C (284°F)					
Controller action	Replaced by new value from AAS system					
	Log	X	Alarm	X	Alarm light	Off
Consequence	Deteriorated control precision in the chill mode.					
Elimination	When sensor value becomes valid, it is marked as inactive in the alarm list and may then be deleted.					
Log data	Parm 1	Parm 2	Parm 3	Parm 4	Parm 5	
	Active/Inactive	Low limit	High limit	Present		



105	Tsup 1 invalid					Alarm
Description	Supply Air Temperature Sensor 1 Invalid					
Cause	Indication of defective supply air temperature sensor, its measuring circuitry or sensor not mounted correctly in unit					
Trouble shooting	<p><u>Possible causes:</u></p> <ul style="list-style-type: none"> • Active alarms AL 103, AL 104 or AL 901 (if CIM5 software) • Temperature sensor reading is out of valid range: -60°C (-76°F) or above +140°C (284°F). • Difference between Tsup1 and Tsup2 is larger than 1°C: 1°C difference for more than 30 min. up to 10°C difference in more than 3 min. <p><u>Accompanied alarms:</u></p> <ul style="list-style-type: none"> • AL 103 or AL 104 may also be active. <p><u>Trouble shooting:</u></p> <ol style="list-style-type: none"> 1) If alarms AL 103 or AL 104 are active, check their trouble shooting section first. 2) Check that both sensors, Tsup1 and Tsup2 are mounted correct in the supply air pockets. 3) If AL 901 is active, see trouble shooting for AL 901 4) Disconnect the sensor cable for sensor Tsup1 from the connector on the main controller, according to the wiring schematics inside in the control cabinet. 5) Measure the resistance between the two wires. <ol style="list-style-type: none"> a) If the resistance is out of range of the resistance and temperature table, "Tables" p. 203 , the temperature sensor and cable are defective and should be replaced. b) If the resistance is within range, perform main controller check "Trouble shooting for Star Cool main controller" p. 57 before replacing main controller. 					
Criteria	Value is below alarm limit -60°C (-76°F) or above +140°C (284°F) or difference between Tsup1 and Tsup2 is more than (>) 1°C (34°F) for 30 min. Value invalid for 30 sec. for alarm activation.					
Controller action	Replacement by new value from AAS system					
	Log	X	Alarm	X	Alarm light	Off
Consequence	Deteriorated control precision in the chill mode.					
Elimination	When sensor value becomes valid, it is marked as inactive in the alarm list and may then be deleted. Value must be valid for 60 sec. to set alarm inactive.					
Log data	Parm 1	Parm 2	Parm 3	Parm 4	Parm 5	
	Active/Inactive					



106	Tsup 2 open					Warning
Description	Supply Air Temperature Sensor 2 Open Circuit					
Cause	Indication of loose connection, defective or lack of supply air temperature sensor					
Trouble shooting	<p><u>Possible causes:</u></p> <ul style="list-style-type: none"> • Temperature sensor Tsup2 or its cable defective. • X24 and X25 cable is defective. • Main controller defective. <p><u>Accompanied alarms:</u></p> <ul style="list-style-type: none"> • AL 108. <p><u>Trouble shooting:</u></p> <p>1) Same trouble shooting is to be used for Tsup2 as used for Tret in AL 100</p>					
Criteria	Value below low alarm limit -60°C (-76°F)					
Controller action	Replacement by new value from AAS system					
	Log	X	Alarm	X	Alarm light	Off
Consequence	Deteriorated control precision in the chill mode.					
Elimination	When sensor value becomes valid, it is marked as inactive in the alarm list and may then be deleted.					
Log data	Parm 1	Parm 2	Parm 3	Parm 4	Parm 5	
	Active/Inactive	Low limit	High limit	Present		

107	Tsup 2 short					Warning
Description	Supply Air Temperature Sensor 2 Short Circuit					
Cause	Indication of short-circuited supply air temperature sensor					
Trouble shooting	<p><u>Possible causes:</u></p> <ul style="list-style-type: none"> • Temperature sensor Tsup2 or its cable defective. • X24 and X25 cable is defective. • Main controller defective. <p><u>Accompanied alarms:</u></p> <ul style="list-style-type: none"> • AL 108. <p><u>Trouble shooting:</u></p> <p>1) Same trouble shooting is to be used for Tsup2 as used for Tret in AL 101.</p>					
Criteria	Value above high alarm limit +140°C (284°F)					
Controller action	Replacement by new value from AAS system					
	Log	X	Alarm	X	Alarm light	Off
Consequence	Deteriorated control precision in the chill mode.					
Elimination	When sensor value becomes valid, it is marked as inactive in the alarm list and may then be deleted.					
Log data	Parm 1	Parm 2	Parm 3	Parm 4	Parm 5	
	Active/Inactive	Low limit	High limit	Present		



108	Tsup 2 invalid					Alarm
Description	Supply Air Temperature Sensor 2 Invalid					
Cause	Indication of defective supply air temperature sensor or its measuring circuitry or sensor not mounted correctly in unit					
Trouble shooting	<p><u>Possible causes:</u></p> <ul style="list-style-type: none"> • Active alarms AL 106, AL 107 or AL 901 (if CIM5 software) • Temperature sensor reading is out of valid range: -60°C (-76°F) or above +140°C (284°F). • Difference between Tsup1 and Tsup2 is larger than 1°C: 1°C difference for more than 30 min. or up to 10°C difference in more than 3 min. <p><u>Accompanied alarms:</u></p> <ul style="list-style-type: none"> • AL 106 or AL 107 may also be active. <p><u>Trouble shooting:</u></p> <ol style="list-style-type: none"> 1) If alarms AL 106 or AL 107 are active, check their trouble shooting section first. 2) Check that both sensors, Tsup1 and Tsup2 are mounted correct in the supply air pockets. 3) If AL 901 is active, see trouble shooting for AL 901 4) Disconnect the sensor cable for sensor Tsup2 from the connector on the main controller, according to the wiring schematics inside in the control cabinet. 5) Measure the resistance between the two wires. <ol style="list-style-type: none"> a) If the resistance is out of range of the resistance and temperature table, "Tables" p. 203, the temperature sensor and cable are defective and should be replaced. b) If the resistance is within range, perform main controller check "Trouble shooting for Star Cool main controller" p. 57 before replacing main controller. 					
Criteria	Value is below alarm limit -60°C (-°F) or above +140°C (284°F) or difference between Tsup1 and Tsup2 is more than (>) 1°C for 30 min. or up to 10°C difference. Value invalid for 30 sec. for alarm activation.					
Controller action	Replacement by new value from AAS system					
	Log	X	Alarm	X	Alarm light	Off
Consequence	Deteriorated control precision in the chill mode.					
Elimination	When sensor value becomes valid, it is marked as inactive in the alarm list and may then be deleted. Value must be valid for 60 sec. to set alarm inactive.					
Log data	Parm 1	Parm 2	Parm 3	Parm 4	Parm 5	
	Active/Inactive					



109	Tusda 1 open					Warning
Description	USDA 1 Temperature Sensor Open Circuit					
Cause	Indication of loose connection, defective or lack of USDA 1 temperature sensor					
Trouble shooting	<p><u>Possible causes:</u></p> <ul style="list-style-type: none"> • Temperature sensor Tusda1 or its cable defective. • X24 and X25 cable is defective. • Defective plug inside or cable on the unit backside. • Main controller defective. <p><u>Accompanied alarms:</u></p> <ul style="list-style-type: none"> • N/A. <p><u>Trouble shooting:</u></p> <ol style="list-style-type: none"> 1) Disconnect the sensor cable for sensor Tusda1 from the connector on the main controller, according to the wiring schematics inside in the control cabinet. 2) Measure the resistance between the two wires. <ol style="list-style-type: none"> a) If the resistance is more than 1.5 MΩ, the cable or the plug on the backside of the unit or the sensor is defective. Check plug before replacing the sensor and cable. b) If the resistance matches the resistance and temperature in "Tables" p. 203, the temperature sensor and cable are OK. 3) Measure the voltage over the connector for Tusda1. It should be between 3.2 and 3.4 V DC <ol style="list-style-type: none"> a) If the voltage is inside the above range, connect sensor again. Measure the voltage over the sensor and check voltage/temperature according to "Tables" p. 203 b) If the voltage is outside the above range, the main controller is defective or other sensors may be defective and pulling the voltage down. Check other alarms and see "Trouble shooting for Star Cool main controller" p. 57 before replacing main controller. 					
Criteria	Value below low alarm limit -60°C (-76°F) and the sensor reading has been in the valid area since power-up.					
Controller action	None					
	Log	X	Alarm	(X)	Alarm light	Off
Consequence	May be incomplete USDA data logging. If activated Cold Treatment (CT), it will be affected.					
Elimination	When sensor value becomes valid, it is marked as inactive in the alarm list and may then be deleted.					
Log data	Parm 1	Parm 2	Parm 3	Parm 4	Parm 5	
	Active/Inactive	Low limit	High limit	Present		



110	Tusda 1 short					Warning
Description	USDA 1 Temperature Sensor Short Circuit					
Cause	Indication of short-circuited USDA 1 temperature sensor					
Trouble shooting	<p><u>Possible causes:</u></p> <ul style="list-style-type: none"> • Temperature sensor Tusda1 or its cable defective. • X24 and X25 cable is defective. • Defective plug inside or cable on the unit backside. • Main controller defective. <p><u>Accompanied alarms:</u></p> <ul style="list-style-type: none"> • N/A. <p><u>Trouble shooting:</u></p> <ol style="list-style-type: none"> 1) Disconnect the sensor cable for sensor Tusda1 from the connector on the main controller, according to the wiring schematics inside in the control cabinet. 2) Measure the resistance between the two wires. <ol style="list-style-type: none"> a) If the resistance is less than (<) 230 Ω, the cable, the plug inside in the unit or the sensor is defective. Check the plug before replacing sensor and cable. b) If the resistance matches the resistance and temperature "Tables" p. 203, the temperature sensor and cable are OK. 3) Measure the voltage over the connector for Tusda1. It should be between 3.2 and 3.4 V DC <ol style="list-style-type: none"> a) If the voltage is inside the above range, connect sensor again. Measure the voltage over the sensor and check voltage/temperature according to table in "Tables" p. 203 b) If the voltage is outside the above range, the main controller is defective or other sensors may be defective and pulling the voltage down. Check other alarms and "Trouble shooting for Star Cool main controller" p. 57 before replacing main controller. 					
Criteria	Value is above high alarm limit +140°C (+284°F) and the sensor reading has been in the valid area since power-up.					
Controller action	None					
	Log	X	Alarm	(X)	Alarm light	Off
Consequence	May be incomplete USDA data logging. If activated Cold Treatment (CT), it will be affected					
Elimination	When sensor value becomes valid, it is marked inactive in the alarm list and may then be deleted.					
Log data	Parm 1	Parm 2	Parm 3	Parm 4	Parm 5	
	Active/Inactive	Low limit	High limit	Present		



111	Tusda 1 invalid					Log
Description	USDA 1 Temperature Sensor Invalid					
Cause	Indication of defective supply air temperature sensor or its measuring circuitry or sensor not mounted correctly in unit					
Trouble shooting	<p><u>Possible causes:</u></p> <ul style="list-style-type: none"> • Active alarms AL 110, AL 109 or AL 901 (if CIM5 software) • Temperature sensor reading is out of valid range: -60°C (-76°F) or above +70°C (284°F). <p><u>Accompanied alarms:</u></p> <ul style="list-style-type: none"> • AL 110, AL 109 or AL 901 may also be active. <p><u>Trouble shooting:</u></p> <ol style="list-style-type: none"> 1) If alarms AL 110 or AL 109 are active, check their trouble shooting section first. 2) If AL 901 is active, see trouble shooting for AL 901 3) Disconnect the sensor cable for sensor Tusda1 from the connector on the main controller, according to the wiring schematics inside in the control cabinet. 4) Measure the resistance between the two wires. <ol style="list-style-type: none"> a) If the resistance is out of range of the resistance and temperature table, "Tables" p. 203, the temperature sensor and cable are defective and should be replaced. b) If the resistance is within range, perform main controller check "Trouble shooting for Star Cool main controller" p. 57 before replacing main controller. 					
Criteria	Activated by UWS or AL 901					
Controller action	Replacement by new value from AAS system					
	Log	X	Alarm	X	Alarm light	Off
Consequence	If activated Cold Treatment (CT), it will be affected					
Elimination	When sensor value becomes valid, it is marked as inactive in the alarm list and may then be deleted. Value must be valid for 60 sec. to set alarm inactive.					
Log data	Parm 1	Parm 2	Parm 3	Parm 4	Parm 5	
	Active/Inactive					



112	Tusda 2 open					Warning
Description	USDA 2 Temperature Sensor Open Circuit					
Cause	Indication of loose connection, defective or lack of USDA 2 temperature sensor.					
Trouble shooting	<p><u>Possible causes:</u></p> <ul style="list-style-type: none"> • Temperature sensor Tusda2 or its cable defective. • Defective plug inside or cable on the unit backside. • Main controller defective. <p><u>Accompanied alarms:</u></p> <ul style="list-style-type: none"> • N/A. <p><u>Trouble shooting:</u></p> <p>1) Same trouble shooting to be used for Tusda2 as used for Tusda1 in AL 109</p>					
Criteria	Value below low alarm limit -60°C (-76°F) and the sensor reading has been in the valid area since power-up.					
Controller action	None					
	Log	X	Alarm	(X)	Alarm light	Off
Consequence	May be incomplete USDA data logging. If activated Cold Treatment (CT), it will be affected					
Elimination	When sensor value becomes valid, it is marked as inactive in the alarm list and may then be deleted.					
Log data	Parm 1	Parm 2	Parm 3	Parm 4	Parm 5	
	Active/Inactive	Low limit	High limit	Present		

113	Tusda 2 short					Warning
Description	USDA 2 Temperature Sensor Short Circuit					
Cause	Indication of short-circuited USDA 2 temperature sensor					
Trouble shooting	<p><u>Possible causes:</u></p> <ul style="list-style-type: none"> • Temperature sensor Tusda2 or its cable defective. • X24 and X25 cable is defective. • Defective plug inside or cable on the unit backside. • Main controller defective. <p><u>Accompanied alarms:</u></p> <ul style="list-style-type: none"> • N/A. <p><u>Trouble shooting:</u></p> <p>1) Same trouble shooting is to be used for Tusda2 as for Tusda1 in AL 110.</p>					
Criteria	Value above high alarm limit +140°C (+284°F) and the sensor reading has been in the valid area since power-up.					
Controller action	None					
	Log	X	Alarm	(X)	Alarm light	Off
Consequence	May be incomplete USDA data logging. If activated Cold Treatment (CT), it will be affected					
Elimination	When sensor value becomes valid, it is marked as inactive in the alarm list and may then be deleted.					
Log data	Parm 1	Parm 2	Parm 3	Parm 4	Parm 5	
	Active/Inactive	Low limit	High limit	Present		



114	Tusda 2 invalid					Log
Description	USDA 2 Temperature Sensor Invalid					
Cause	Indication of defective supply air temperature sensor or its measuring circuitry or sensor not mounted correctly in unit					
Trouble shooting	<p><u>Possible causes:</u></p> <ul style="list-style-type: none"> Active alarms AL 112, AL 113 or AL 901 (if CIM5 software) Temperature sensor reading is out of valid range: -60°C (-76°F) or above +140°C (284°F). <p><u>Accompanied alarms:</u></p> <ul style="list-style-type: none"> AL 112, AL 113 or AL 901 may also be active. <p><u>Trouble shooting:</u></p> <ol style="list-style-type: none"> If alarms AL 112 or AL 113 are active, check their trouble shooting section first. If AL 901 is active, see trouble shooting for AL 901 Disconnect the sensor cable for sensor Tusda1 from the connector on the main controller, according to the wiring schematics inside in the control cabinet. Measure the resistance between the two wires. <ol style="list-style-type: none"> If the resistance is out of range of the resistance and temperature table in "Tables" p. 203, the temperature sensor and cable are defective and should be replaced. If the resistance is within range, perform main controller check "Trouble shooting for Star Cool main controller" p. 57 before replacing main controller. 					
Criteria	Activated by UWS or AL 901					
Controller action	Replacement by new value from AAS system					
	Log	X	Alarm	X	Alarm light	Off
Consequence	If activated Cold Treatment (CT), it will be affected					
Elimination	When sensor value becomes valid, it is marked as inactive in the alarm list and may then be deleted. Value must be valid for 60 sec. to set alarm inactive.					
Log data	Parm 1	Parm 2	Parm 3	Parm 4	Parm 5	
	Active/Inactive					



115	Tusda 3 open					Warning
Description	USDA 3 Temperature Sensor Open Circuit					
Cause	Indication of loose connection, defective or lack of USDA 3 temperature sensor					
Trouble shooting	<p><u>Possible causes:</u></p> <ul style="list-style-type: none"> • Temperature sensor Tusda3 or its cable defective. • X22, X23, X24 and X25 cable is defective. • Defective plug inside or cable on the unit backside. • Main controller defective. <p><u>Accompanied alarms:</u></p> <ul style="list-style-type: none"> • N/A. <p><u>Trouble shooting:</u></p> <p>1) Same trouble shooting is to be used for Tusda3 as used for Tusda1 in AL 109</p>					
Criteria	Value below low alarm limit -60°C (-76°F) and the sensor reading has been in the valid area since power-up.					
Controller action	None					
	Log	X	Alarm	(X)	Alarm light	Off
Consequence	May be incomplete USDA data logging. If activated Cold Treatment (CT), it will be affected.					
Elimination	When sensor value becomes valid, it is marked as inactive in the alarm list and may then be deleted.					
Log data	Parm 1	Parm 2	Parm 3	Parm 4	Parm 5	
	Active/Inactive	Low limit	High limit	Present		

116	Tusda 3 short					Warning
Description	USDA 3 Temperature Sensor Short Circuit					
Cause	Indication of short-circuited USDA 3 temperature sensor					
Trouble shooting	<p><u>Possible causes:</u></p> <ul style="list-style-type: none"> • Temperature sensor Tusda3 or its cable defective. • X24 and X25 cable is defective. • Defective plug inside or cable on the unit backside. • Main controller defective. <p><u>Accompanied alarms:</u></p> <ul style="list-style-type: none"> • N/A. <p><u>Trouble shooting:</u></p> <p>1) Same trouble shooting is to be used for Tusda3 as for Tusda1 in AL 110.</p>					
Criteria	Value above high alarm limit +140°C (+284°F) and the sensor reading has been in the valid area since power-up.					
Controller action	None					
	Log	X	Alarm	(X)	Alarm light	Off
Consequence	May be incomplete USDA data logging. If activated Cold Treatment (CT), it will be affected.					
Elimination	When sensor value becomes valid, it is marked as inactive in the alarm list and may then be deleted.					
Log data	Parm 1	Parm 2	Parm 3	Parm 4	Parm 5	
	Active/Inactive	Low limit	High limit	Present		



117	Tusda 3 invalid					Log
Description	USDA 3 Temperature Sensor Invalid					
Cause	Indication of defective supply air temperature sensor or its measuring circuitry or sensor not mounted correctly in unit					
Trouble shooting	<p><u>Possible causes:</u></p> <ul style="list-style-type: none"> Active alarms AL 115, AL 116 or AL 901 (if CIM5 software) Temperature sensor reading is out of valid range: -60°C (-76°F) or above +140°C (284°F). <p><u>Accompanied alarms:</u></p> <ul style="list-style-type: none"> AL 115, AL 116 or AL 901 may also be active. <p><u>Trouble shooting:</u></p> <ol style="list-style-type: none"> If alarms AL 115 or AL 116 are active, check their trouble shooting section first. If AL 901 is active, see trouble shooting for AL 901 Disconnect the sensor cable for sensor Tusda1 from the connector on the main controller, according to the wiring schematics inside in the control cabinet. Measure the resistance between the two wires. <ol style="list-style-type: none"> If the resistance is out of range of the resistance and temperature table in "Tables" p. 203 the temperature sensor and cable are defective and should be replaced. If the resistance is within range, perform main controller check "Trouble shooting for Star Cool main controller" p. 57 before replacing main controller. 					
Criteria	Activated by UWS or AL 901					
Controller action	Replacement by new value from AAS system					
	Log	X	Alarm	X	Alarm light	Off
Consequence	If activated Cold Treatment (CT), it will be affected					
Elimination	When sensor value becomes valid, it is marked as inactive in the alarm list and may then be deleted. Value must be valid for 60 sec. to set alarm inactive.					
Log data	Parm 1	Parm 2	Parm 3	Parm 4	Parm 5	
	Active/Inactive					



118	Tcargo open					Warning
Description	Cargo Temperature Sensor Open Circuit					
Cause	Indication of loose connection, defective or lack of cargo temperature sensor					
Trouble shooting	<p><u>Possible causes:</u></p> <ul style="list-style-type: none"> • Temperature sensor Tcargo or its cable defective. • X24 and X25 cable is defective. • Defective plug inside or cable on the unit backside. • Main controller defective. <p><u>Accompanied alarms:</u></p> <ul style="list-style-type: none"> • N/A. <p><u>Trouble shooting:</u></p> <p>1) Same trouble shooting is to be used for Tcargo as used for Tusda1 AL 109.</p>					
Criteria	Value below low alarm limit -60°C (-76°F) and the sensor reading has been in the valid area since power-up.					
Controller action	None					
	Log	X	Alarm	(X)	Alarm light	Off
Consequence	May be incomplete cargo data logging					
Elimination	When sensor value becomes valid, it is marked as inactive in the alarm list and may then be deleted.					
Log data	Parm 1	Parm 2	Parm 3	Parm 4	Parm 5	
	Active/Inactive	Low limit	High limit	Present		

119	Tcargo short					Warning
Description	Cargo Temperature Sensor Short Circuit					
Cause	Indication of short-circuited cargo temperature sensor					
Trouble shooting	<p><u>Possible causes:</u></p> <ul style="list-style-type: none"> • Temperature sensor Tcargo or its cable defective. • X24 and X25 cable is defective. • Defective plug inside or cable on the unit backside. • Main controller defective. <p><u>Accompanied alarms:</u></p> <ul style="list-style-type: none"> • N/A. <p><u>Trouble shooting:</u></p> <p>1) Same trouble shooting is to be used for Tcargo as for Tusda1 in AL 110.</p>					
Criteria	Value above high alarm limit +140°C (+284°F) and the sensor reading has been in the valid area since power-up.					
Controller action	None					
	Log	X	Alarm	(X)	Alarm light	Off
Consequence	May be incomplete cargo data logging					
Elimination	When sensor value becomes valid, it is marked as inactive in the alarm list and may then be deleted.					
Log data	Parm 1	Parm 2	Parm 3	Parm 4	Parm 5	
	Active/Inactive	Low limit	High limit	Present		



120	Tcargo invalid					Log
Description	Cargo Temperature Sensor Invalid					
Cause	Indication of defective supply air temperature sensor or its measuring circuitry or sensor not mounted correctly in unit					
Trouble shooting	<p><u>Possible causes:</u></p> <ul style="list-style-type: none"> Active alarms AL 118, AL 119 or AL 901 (if CIM5 software) Temperature sensor reading is out of valid range: -60°C (-76°F) or above +140°C (284°F). <p><u>Accompanied alarms:</u></p> <ul style="list-style-type: none"> AL 118, AL 119 or AL 901 may also be active. <p><u>Trouble shooting:</u></p> <ol style="list-style-type: none"> If alarms AL 118 or AL 119 are active, check their trouble shooting section first. If AL 901 is active, see trouble shooting for AL 901 Disconnect the sensor cable for sensor Tusda1 from the connector on the main controller, according to the wiring schematics inside in the control cabinet. Measure the resistance between the two wires. <ol style="list-style-type: none"> If the resistance is out of range of the resistance and temperature in "Tables" p. 203 the temperature sensor and cable are defective and should be replaced. If the resistance is within range, perform main controller check "Trouble shooting for Star Cool main controller" p. 57 before replacing main controller. 					
Criteria	Activated by UWS or AL 901					
Controller action	Replacement by new value from AAS system					
	Log	X	Alarm	X	Alarm light	Off
Consequence	If activated Cold Treatment (CT), it will be affected					
Elimination	When sensor value becomes valid, it is marked as inactive in the alarm list and may then be deleted. Value must be valid for 60 sec. to set alarm inactive.					
Log data	Parm 1	Parm 2	Parm 3	Parm 4	Parm 5	
	Active/Inactive					



121	Tevap open					Warning
Description	Evaporator Temperature Sensor Open Circuit					
Cause	Indication of loose connection, defective or lack of evaporator temperature sensor					
Trouble shooting	<p><u>Possible causes:</u></p> <ul style="list-style-type: none"> • Temperature sensor Tevap or its cable defective. • X24 and X25 cable is defective. • Main controller defective. <p><u>Accompanied alarms:</u></p> <ul style="list-style-type: none"> • AL 123. <p><u>Trouble shooting:</u></p> <p>1) Same trouble shooting is to be used for Tevap as used for Tret in AL 100</p>					
Criteria	Value below low alarm limit -60°C (-76°F)					
Controller action	Replacement by new value from AAS system					
	Log	X	Alarm	X	Alarm light	Off
Consequence						
Elimination	When sensor value becomes valid, it is marked as inactive in the alarm list and may then be deleted.					
Log data	Parm 1	Parm 2	Parm 3	Parm 4	Parm 5	
	Active/Inactive	Low limit	High limit	Present		

122	Tevap short					Warning
Description	Evaporator Temperature Sensor Short Circuit					
Cause	Indication of short-circuited evaporator temperature sensor					
Trouble shooting	<p><u>Possible causes:</u></p> <ul style="list-style-type: none"> • Temperature sensor Tevap or its cable defective. • X24 and X25 cable is defective. • Main controller defective. <p><u>Accompanied alarms:</u></p> <ul style="list-style-type: none"> • AL 123. <p><u>Trouble shooting:</u></p> <p>1) Same trouble shooting is to be used for Tevap as used for Tret in AL 101.</p>					
Criteria	Value above high alarm limit +140°C (+284°F)					
Controller action	Replacement by new value from AAS system					
	Log	X	Alarm	X	Alarm light	Off
Consequence						
Elimination	When sensor value becomes valid, it is marked as inactive in the alarm list and may then be deleted.					
Log data	Parm 1	Parm 2	Parm 3	Parm 4	Parm 5	
	Active/Inactive	Low limit	High limit	Present		



123	Tevap invalid					Warning
Description	Evaporator Temperature Sensor Invalid					
Cause	Indication of defective evaporator temperature sensor or its measuring circuitry					
Trouble shooting	<p><u>Possible causes:</u></p> <ul style="list-style-type: none"> • Active alarms AL 121, AL 122 or AL 901 (if CIM5 software) • Temperature sensor reading is out of valid range: -60°C (-76°F) or above +140°C (284°F). <p><u>Accompanied alarms:</u></p> <ul style="list-style-type: none"> • AL 121 or AL 22 may also be active. <p><u>Trouble shooting:</u></p> <ol style="list-style-type: none"> 1) If alarms AL 121 or AL 122 are active, check their trouble shooting section first. 2) Disconnect the sensor cable for sensor Tevap from the connector on the main controller, according to the wiring schematics inside in the control cabinet. 3) If AL 901 is active, see trouble shooting for AL 901 4) Measure the resistance between the two wires. <ol style="list-style-type: none"> a) If the resistance is out of range of the resistance and temperature table in "Tables" p. 203 the temperature sensor and cable are defective and should be replaced. b) If the resistance is within range, perform main controller check "Trouble shooting for Star Cool main controller" p. 57 before replacing main controller. 					
Criteria	Value below alarm limit -60°C (-76°F) or above +140°C (+284°F). Value must be invalid for 30 sec. for alarm activation.					
Controller action	Replacement by new value from AAS system					
	Log	X	Alarm	X	Alarm light	Off
Consequence						
Elimination	When sensor value becomes valid, it is marked as inactive in the alarm list and may then be deleted. Value must be valid for 60 sec. to set alarm inactive.					
Log data	Parm 1	Parm 2	Parm 3	Parm 4	Parm 5	
	Active/Inactive					



124	Tsuc open					Warning
Description	Suction Temperature Sensor Open Circuit					
Cause	Indication of loose connection, defective or complete lack of suction temperature sensor					
Trouble shooting	<p><u>Possible causes:</u></p> <ul style="list-style-type: none"> • Temperature sensor Tsuc or its cable defective. • X24 and X25 cable is defective. • Main controller defective. <p><u>Accompanied alarms:</u></p> <ul style="list-style-type: none"> • AL 126. <p><u>Trouble shooting:</u></p> <p>1) Same trouble shooting is to be used for Tsuc as used for Tret in AL 100.</p>					
Criteria	Value below low alarm limit -60°C (-76°F)					
Controller action	Replacement by new value from AAS system					
	Log	X	Alarm	X	Alarm light	Off
Consequence	Superheat control deactivation					
Elimination	When sensor value becomes valid, it is marked as inactive in the alarm list and may then be deleted.					
Log data	Parm 1	Parm 2	Parm 3	Parm 4	Parm 5	
	Active/Inactive	Low limit	High limit	Present		

125	Tsuc short					Warning
Description	Suction Temperature Sensor Short Circuit					
Cause	Indication of short-circuited suction temperature sensor					
Trouble shooting	<p><u>Possible causes:</u></p> <ul style="list-style-type: none"> • Temperature sensor Tsuc or its cable defective. • X24 and X25 cable is defective. • Main controller defective. <p><u>Accompanied alarms:</u></p> <ul style="list-style-type: none"> • AL 126. <p><u>Trouble shooting:</u></p> <p>1) Same trouble shooting is to be used for Tsuc as used for Tret in AL 101.</p>					
Criteria	Value above high alarm limit +140°C (+284°F)					
Controller action	Replacement by new value from AAS system					
	Log	X	Alarm	X	Alarm light	Off
Consequence	Superheat control deactivation					
Elimination	When sensor value becomes valid, it is marked as inactive in the alarm list and may then be deleted.					
Log data	Parm 1	Parm 2	Parm 3	Parm 4	Parm 5	
	Active/Inactive	Low limit	High limit	Present		



126	Tsuc invalid					Warning
Description	Suction Temperature Sensor Invalid					
Cause	Indication of defective suction temperature sensor or its measuring circuitry					
Trouble shooting	<p><u>Possible causes:</u></p> <ul style="list-style-type: none"> • Active alarms AL 124, AL 125 or AL 901 (if CIM5 software) • Temperature sensor reading is out of valid range: -60°C (-76°F) or above +140°C (+284°F). <p><u>Accompanied alarms:</u></p> <ul style="list-style-type: none"> • AL 124, AL 125 or AL 901 may also be active. <p><u>Trouble shooting:</u></p> <ol style="list-style-type: none"> 1) If alarms AL 124 or AL 125 are active, check their trouble shooting section first. 2) Disconnect the sensor cable for sensor Tsuc from the connector on the main controller, according to the wiring schematics inside in the control cabinet. 3) If AL 901 is active, see trouble shooting for AL 901 4) Measure the resistance between the two wires. <ol style="list-style-type: none"> a) If the resistance is out of range of the resistance and temperature in "Tables" p. 203 the temperature sensor and cable are defective and should be replaced. b) If the resistance is within range, perform main controller check "Tables" p. 203 before replacing main controller. 					
Criteria	Value below alarm limit -60°C (-76°F) or above +140°C (+284°F). Value must be invalid for 30 sec. for alarm activation.					
Controller action	Replacement by new value from AAS system					
	Log	X	Alarm	X	Alarm light	Off
Consequence	Superheat control deactivation					
Elimination	When sensor value becomes valid, it is marked as inactive in the alarm list and may then be deleted.					
Log data	Parm 1	Parm 2	Parm 3	Parm 4	Parm 5	
	Active/Inactive					



127	Tamb open					Warning
Description	Ambient Temperature Sensor Open Circuit					
Cause	Indication of loose connection, defective or lack of ambient temperature sensor					
Trouble shooting	<p><u>Possible causes:</u></p> <ul style="list-style-type: none"> • Temperature sensor Tamb or its cable defective. • X24 and X25 cable is defective. • Main controller defective. <p><u>Accompanied alarms:</u></p> <ul style="list-style-type: none"> • AL 129. <p><u>Trouble shooting:</u></p> <p>1) Same trouble shooting is to be used for Tamb as used for Tret in AL 100.</p>					
Criteria	Value below low alarm limit -60°C (-76°F)					
Controller action	Replacement by new value from AAS system					
	Log	X	Alarm	X	Alarm light	Off
Consequence	No consequence as to control					
Elimination	When sensor value becomes valid, it is marked as inactive in the alarm list and may then be deleted.					
Log data	Parm 1	Parm 2	Parm 3	Parm 4	Parm 5	
	Active/Inactive	Low limit	High limit	Present		

128	Tamb short					Warning
Description	Ambient Temperature Sensor Short Circuit					
Cause	Indication of short-circuited ambient temperature sensor					
Trouble shooting	<p><u>Possible causes:</u></p> <ul style="list-style-type: none"> • Temperature sensor Tamb or its cable defective. • X24 and X25 cable is defective. • Main controller defective. <p><u>Accompanied alarms:</u></p> <ul style="list-style-type: none"> • AL 129. <p><u>Trouble shooting:</u></p> <p>1) Same trouble shooting is to be used for Tamb as used for Tret in AL 101.</p>					
Criteria	Value above high alarm limit +140°C (+284°F)					
Controller action	Replacement by new value from AAS system					
	Log	X	Alarm	X	Alarm light	Off
Consequence	No consequence as to control					
Elimination	When sensor value becomes valid, it is marked as inactive in the alarm list and may then be deleted.					
Log data	Parm 1	Parm 2	Parm 3	Parm 4	Parm 5	
	Active/Inactive	Low limit	High limit	Present		



129	Tamb invalid					Warning
Description	Ambient Temperature Sensor Invalid					
Cause	Indication of defective supply ambient sensor or its measuring circuitry					
Trouble shooting	<p><u>Possible causes:</u></p> <ul style="list-style-type: none"> Active alarms AL 127, AL 128 or AL 901 (if CIM5 software) Temperature sensor reading is out of valid range: -60°C (-76°F) or above +140°C (+284°F). <p><u>Accompanied alarms:</u></p> <ul style="list-style-type: none"> AL 127, AL 128 or AL 901 may also be active. <p><u>Trouble shooting:</u></p> <ol style="list-style-type: none"> If alarms AL 127 or AL 128 are active, check their trouble shooting section first. Disconnect the sensor cable for sensor Tamb from the connector on the main controller, according to the wiring schematics inside in the control cabinet. If AL 901 is active, see trouble shooting for AL 901 Measure the resistance between the two wires. <ol style="list-style-type: none"> If the resistance is out of range of the resistance and temperature table, "Tables" p. 203 the temperature sensor and cable are defective and should be replaced. If the resistance is within range, perform main controller check "Trouble shooting for Star Cool main controller" p. 57 before replacing main controller. 					
Criteria	Value below alarm limit -60°C (-58°F) or above +140°C (284°F). Value must be invalid for 30 sec. for alarm activation.					
Controller action	Replacement by new value from AAS system					
	Log	X	Alarm	X	Alarm light	Off
Consequence	No consequence as to control					
Elimination	When sensor value becomes valid, it is marked as inactive in the alarm list and may then be deleted. Value must be valid for 120 sec. to set alarm inactive.					
Log data	Parm 1	Parm 2	Parm 3	Parm 4	Parm 5	
	Active/Inactive					

Pressure transmitter Alarms (AL 2XX)

200	Pdis open (see AL 202)	Warning
201	Pdis short (see AL 202)	Warning



202	Pdis fault					Warning	
Description	Compressor Discharge Pressure Transmitter Open or Short Circuit						
Cause	Indication of loose connection, defective, short-circuited or lack of compressor discharge pressure transmitter.						
Trouble shooting	<p><u>Possible causes:</u></p> <ul style="list-style-type: none"> • Connector for high HP transmitter Pdis disconnected or not correctly mounted. • HP transmitter Pdis defective. • Cable for HP transmitter Pdis defective. • X22 and cable is defective. • Main controller defective. <p><u>Accompanied alarms:</u></p> <ul style="list-style-type: none"> • AL 200 or AL 201 or AL 203 may also be active. <p><u>Trouble shooting:</u></p> <p>Disconnect the cable for Pdis from the main controller according to the wiring schematics inside the control cabinet and from the HP transmitter.</p> <p>1) Check that the connector is mounted correctly according to the drawing for pressure transmitter AKS or NSK respectively. The earth stud must be on the opposite side of the cable (AKS):</p> <div style="display: flex; justify-content: space-around;"> <div data-bbox="483 913 657 1120"> <p>Figure for AKS</p> </div> <div data-bbox="738 936 987 1120"> <p>Figure for NSK</p> </div> </div> <p>2) Check the cable (measure the resistance in the cable). If the cable is defective, replace cable.</p> <p>3) Mount the cable for Pdis in controller cabinet and on the transmitter. Disconnect signal wire on main controller. Measure voltage between wire and GND on main controller. AKS: If voltage is below 0.5 V DC, transmitter or connection between transmitter and cable is defective. If voltage is between 0.5 V DC and 4.5 V DC, continue to 4). NSK: If voltage is below 0.37 V DC, transmitter or connection between transmitter and cable is defective. If voltage is between 0.37 V DC and 4.0 V DC, continue to 4).</p> <p>4) Mount signal wire. Measure voltage between SIGNAL and GND. AKS: If voltage is between 0.5 V DC and 4.5 V DC and this alarm is still active, replace main controller. NSK: If the voltage is between 0.37 V DC and 4.0 V DC and this alarm is still active, replace main controller.</p> <p>Before replacing main controller see "Trouble shooting for Star Cool main controller" p. 57</p>						
Criteria	Value above high alarm limit 32 BarE (464 Psi) for AKS Value above high alarm limit 30 BarE (435 Psi) for NSK Value below low alarm limit -0.1 BarE (-1.5 Psi) AKS Value below low alarm limit -0.15 BarE (-2 Psi) NSK						
Controller action	Replacement by new value from AAS system						
	Log	X	Alarm	X	Alarm light	Off	
Consequence							
Elimination	When transmitter value becomes valid, it is marked as inactive in the alarm list and may then be deleted. Value must be valid for 120 sec. to set alarm inactive.						
Log data	Parm 1	Parm 2	Parm 3	Parm 4	Parm 5		
	Active/Inactive	Low limit	High limit	Present 6 sec			



203	Pdis invalid					Warning
Description	Compressor Discharge Pressure Transmitter Invalid					
Cause	Indication of defective compressor discharge pressure transmitter or its measuring circuitry					
Trouble shooting	<p><u>Possible causes:</u></p> <ul style="list-style-type: none"> • Connector for high pressure transmitter Pdis not correctly mounted. • High pressure transmitter Pdis defective. • Cable for high pressure transmitter Pdis defective. • X22 and cable is defective. • Main controller defective. <p><u>Accompanied alarms:</u></p> <ul style="list-style-type: none"> • AL 200, AL 201 or AL 202 may also be active. <p><u>Trouble shooting:</u></p> <p>See Trouble shooting for AL 202</p>					
Criteria	Value below alarm limit 0.1 BarE (2 Psi) or above 30/31.9 BarE (435/462 Psi). Value invalid for 30 sec. for alarm activation.					
Controller action	Replacement by new value from AAS system					
	Log	X	Alarm	X	Alarm light	Off
Consequence						
Elimination	When transmitter value becomes valid, it is marked as inactive in alarm list and may then be deleted. Value must be valid for 60 sec. to set alarm inactive.					
Log data	Parm 1	Parm 2	Parm 3	Parm 4	Parm 5	
	Active/Inactive					

204	Psuc open (see AL 206)	Warning
------------	-------------------------------	----------------

205	Psuc short (see AL 206)	Warning
------------	--------------------------------	----------------



206	Psuc fault				Warning	
Description	Compressor Suction Pressure Transmitter Open or Short Circuit					
Cause	Indication of loose connection, short-circuited, defective or complete lack of compressor suction pressure transmitter.					
Trouble shooting	<p><u>Possible causes:</u></p> <ul style="list-style-type: none"> • Connector for suction pressure transmitter Psuc disconnected or not correctly mounted. • Suction pressure transmitter Psuc defective. • Cable for suction pressure transmitter Psuc defective. • X22 and cable is defective. • Shortage between Ground and Output • Main controller defective. <p><u>Accompanied alarms:</u></p> <ul style="list-style-type: none"> • AL 204 or AL 205 or AL 207 may also be active. <p><u>Trouble shooting:</u></p> <p>Disconnect the cable for Psuc on the main controller according to the wiring schematics inside the control cabinet and from the suction pressure transmitter.</p> <p>1) Check that the connector is mounted correctly according to the drawing for pressure transmitter AKS or NSK respectively. The earth stud must be on the opposite side of the cable (AKS):</p> <div style="display: flex; justify-content: space-around;"> <div style="text-align: center;"> <p>Figure for AKS</p> </div> <div style="text-align: center;"> <p>Figure for NSK</p> </div> </div> <p>2) Check the cable (measure the resistance in the cable). If the cable is defective, replace cable.</p> <p>3) Mount the cable for Psuc in controller cabinet and on the transmitter. Disconnect signal wire on main controller. Measure voltage between wire and GND on main controller. AKS: If voltage is below 0.5 V DC, transmitter or connection between transmitter and cable is defective. If voltage is between 0.5 V DC and 4.5 V DC, continue to 4). NSK: If voltage is below 0.37 V DC, transmitter or connection between transmitter and cable is defective. If voltage is between 0.37 V DC and 4.0 V DC, continue to 4).</p> <p>4) Mount signal wire. Measure voltage between SIGNAL and GND. AKS: If voltage is between 0.5 V DC and 4.5 V DC and this alarm is still active, replace main controller. NSK: If the voltage is between 0.37 V DC and 4.0 V DC and this alarm is still active, replace main controller.</p> <p>Before replacing main controller see "Trouble shooting for Star Cool main controller" p. 57</p>					
Criteria	Value below low limit -1.1 BarE (-16 Psi) for AKS Value below low limit -0.9 BarE (-13 Psi) for NSK Value above high alarm limit 11.9 BarE (172 Psi) for AKS Value above high alarm limit 9.8 BarE (142 Psi) for NSK					
Controller action	Replacement by new value from AAS system					
Consequence	Log	X	Alarm	X	Alarm light	Off
Elimination	When sensor value becomes valid, it is marked as inactive in alarm list. Can be deleted.					
Log data	Parm 1	Parm 2	Parm 3	Parm 4	Parm 5	
Log data	Active/Inactive	Low limit	High limit	Present 6 sec		



207	Psuc invalid					Warning
Description	Compressor Suction Pressure transmitter Invalid					
Cause	Indication of defective compressor suction pressure transmitter or its measuring circuitry					
Trouble shooting	<p><u>Possible causes:</u></p> <ul style="list-style-type: none"> • Connector for suction pressure transmitter Psuc not correctly mounted. • Suction pressure transmitter Psuc defective. • Cable for suction pressure transmitter Psuc defective. • X22 and cable is defective. • Main controller defective. <p><u>Accompanied alarms:</u></p> <ul style="list-style-type: none"> • AL 204, AL 205, AL 206 or 250 may also be active. <p><u>Trouble shooting:</u></p> <p>See Trouble shooting for AL 206</p>					
Criteria	Value below alarm limit -0.9 BarE (-13 Psi) or above 11.8 BarE (171 Psi). Value invalid for 30 sec. for alarm activation.					
Controller action	Replacement by new value from AAS system.					
	Log	X	Alarm	X	Alarm light	Off
Consequence						
Elimination	When sensor value becomes valid, it is marked as inactive in alarm list and may then be deleted. Value must be valid for 60 sec. to set alarm inactive					
Log data	Parm 1	Parm 2	Parm 3	Parm 4	Parm 5	
	Active/Inactive	0	0	0		

250	Press sensor type					Alarm
Description	Saved FC ID (controller) does not match the current FC ID					
Cause	Controller or FC has been replaced, requires manually setting of pressure transmitter (NSK / ASK)					
Trouble shooting	<p><u>Possible causes:</u></p> <ul style="list-style-type: none"> • Wrong settings NSK / AKS • Pressure transmitter or high pressure switch defective <p><u>Accompanied alarms:</u></p> <ul style="list-style-type: none"> • AL 207, AL 611 and or AL 845 <p><u>Trouble shooting:</u></p> <ol style="list-style-type: none"> 1. Manually select the type of pressure transmitters in the configuration on menu F07 and F08. 2. If AL 845 is accompanied, see trouble shooting for AL 845 					
Criteria	The saved Frequency Converter ID does not match the new Frequency Converter ID in the controller.					
Controller action	Replacement by new value from AAS system.					
	Log	X	Alarm	X	Alarm light	On
Consequence	The unit will continue operation with AAS value.					
Elimination	The operator has to manually select the type of pressure transmitters in the configuration on menu F07 and F08					
Log data	Parm 1	Parm 2	Parm 3	Parm 4	Parm 5	
	Active/Inactive	T0	Tc	LP Type	HP Type	



Other Sensor Alarms (AL 3XX)

302	RH invalid					Log
Description	Relative Humidity Sensor Invalid					
Cause	Indication of defective relative humidity sensor or its measuring circuitry					
Trouble shooting	<p><u>Possible causes:</u></p> <ul style="list-style-type: none"> Relative humidity sensor RH or cable defective. X10 cable is defective. Main controller defective. <p><u>Accompanied alarms:</u></p> <ul style="list-style-type: none"> AL 300 or AL 301 may also be active. <p><u>Trouble shooting:</u></p> <p>Disconnect the cable for RH on the main controller according to the wiring schematics inside the control cabinet and from the RH sensor.</p> <ol style="list-style-type: none"> If the cable by inspection is defective, replace cable. Dismount the sensor from the cable. Dismount the cable terminals from the controller. Measure the resistance between the terminals at the controller end. If the resistance is less than (<) 230 Ω, the cable is defective and must be replaced. Mount the cable for RH in controller cabinet and on the sensor. Disconnect signal wire on main controller. Measure voltage between wire and GND on the main controller. If voltage is below 0.5 V DC, sensor or connection between sensor and cable is defective. If voltage is between 0.5 V DC and 10 V DC, continue to 4). Mount signal wire. Measure voltage between SIGNAL and GND. If voltage is between 0.5 V DC and 10 V DC and this alarm is still active, replace main controller. <p>Before replacing main controller see "Trouble shooting for Star Cool main controller" p. 57</p>					
Criteria	Value below alarm limit 10% RH or above 110% RH. Value invalid for 120 sec. for alarm activation.					
Controller action	None					
	Log	X	Alarm	X	Alarm light	Off
Consequence	Dehumidification impossible					
Elimination	When sensor value becomes valid, it is marked as inactive in alarm list and may then be deleted. Value must be valid for 120 sec. to set alarm inactive.					
Log data	Parm 1	Parm 2	Parm 3	Parm 4	Parm 5	
	Active/Inactive					



303	AirEx No connection				Warning	
Description	Air Exchange Sensor Short Circuit					
Cause	Indication of a loose connection, defective or lack of air exchange sensor					
Trouble shooting	<p><u>Possible causes:</u></p> <ul style="list-style-type: none"> • AirEx is out of calibration • Air exchange sensor AirEx or cable defective. • X23 cable is defective. • Main controller defective. <p><u>Accompanied alarms:</u></p> <ul style="list-style-type: none"> • AL 305. <p><u>Trouble shooting:</u></p> <ol style="list-style-type: none"> 1) If the cable by inspection is defective, replace cable. 2) Calibrate AirEx see "Calibration of air exchange sensor" p. 188. If the value shown in controller is wrong or alarm still active then disconnect the cable for AirEx on the main controller according to the wiring schematics inside the control cabinet and from the AirEx sensor. 3) Mount the cable for AirEx in controller cabinet and on the sensor. Disconnect signal wire on main controller. Measure voltage between wire and GND on the main controller. If the voltage is over 4.0 V DC, sensor or connection between sensor and cable is defective. If the voltage is between 0.2 V DC and 4.0 V DC, continue to 4). 4) Mount signal wire. Measure voltage between SIGNAL and GND. If the voltage is between 0.2 V DC and 4.0 V DC and this alarm is still active continue to 5). 5) Check controller, see "Trouble shooting for Star Cool main controller" p. 57 before replacing main controller. 					
Criteria	Value above alarm limit 225 m3/hour					
Controller action	None					
	Log	X	Alarm	X	Alarm light	Off
Consequence						
Elimination	When sensor value becomes valid, it is marked as inactive in alarm list and may then be deleted.					
Log data	Parm 1	Parm 2	Parm 3	Parm 4	Parm 5	
	Active/Inactive	Low limit	High limit	Present		



304	AirEx short					Warning	
Description	Air Exchange Sensor Short Circuit. <i>Not implemented yet</i>						
Cause	Indication of short-circuited air exchange sensor						
Trouble shooting	<p><u>Possible causes:</u></p> <ul style="list-style-type: none"> • AirEx is out of calibration • Air exchange sensor AirEx or cable defective. • X23 cable is defective. • Main controller defective. <p><u>Accompanied alarms:</u></p> <ul style="list-style-type: none"> • AL 305. <p><u>Trouble shooting:</u></p> <ol style="list-style-type: none"> 1) If the cable by inspection is defective, replace cable. 2) Calibrate AirEx, see "Calibration of air exchange sensor" p. 188 If the value shown in controller is wrong or alarm still active, then disconnect the cable for AirEx on the main controller according to the wiring schematics inside the control cabinet and from the AirEx sensor. 3) Mount the cable for AirEx in controller cabinet and on the sensor. Disconnect signal wire on main controller. Measure voltage between wire and GND on the main controller. If the voltage is below 0.2 V DC, sensor or connection between sensor and cable is defective. If the voltage is between 0.2 V DC and 4.0 V DC, continue to 4). 4) Mount signal wire. Measure voltage between SIGNAL and GND. If the voltage is between 0.2 V DC and 4.0 V DC and this alarm is still active, continue to 5) 5) Check controller, see "Trouble shooting for Star Cool main controller" p. 57 before replacing main controller. 						
Criteria	Value below alarm limit 0 m3/hour						
Controller action	None						
	Log	X	Alarm	X	Alarm light	Off	
Consequence							
Elimination	When sensor value becomes valid, it is marked as inactive in alarm list and may then be deleted.						
Log data	Parm 1	Parm 2	Parm 3	Parm 4	Parm 5		
	Active/Inactive	Low limit	High limit	Present			



305	AirEx invalid				Log
Description	Air Exchange Sensor Invalid. <i>Alarm not implemented yet!</i>				
Cause	Indication of defective air exchange sensor or its measuring circuitry				
Trouble shooting	<p><u>Possible causes:</u></p> <ul style="list-style-type: none"> • AirEx is out of calibration • Air exchange sensor AirEx or cable defective. • X23 cable is defective. • Main controller defective. <p><u>Accompanied alarms:</u></p> <ul style="list-style-type: none"> • AL 303 or AL 304 may also be active. <p><u>Trouble shooting:</u></p> <ol style="list-style-type: none"> 1) If the cable by inspection is defective, replace cable. 2) Calibrate AirEx, see "Calibration of air exchange sensor" p. 188. If the value shown in controller is wrong or alarm still active then Disconnect the cable for AirEx on the main controller according to the wiring schematics inside the control cabinet and from the AirEx sensor. 3) Mount the cable for AirEx in controller cabinet and on the sensor. Disconnect signal wire on main controller. Measure voltage between wire and GND on the main controller. If the voltage is below 0.2 V DC, sensor or connection between sensor and cable is defective. If the voltage is between 0.0 V DC and 4.0 V DC, continue to 4). 4) Mount signal wire. Measure voltage between SIGNAL and GND. If the voltage is between 0.2 V DC and 4.0 V DC and this alarm is still active, continue to 5) 5) Check controller, see "Trouble shooting for Star Cool main controller" p. 57 before replacing main controller. 				
Criteria	Value above alarm limit 225 m3/hour Value below alarm limit 0 m3/hour				
Controller action					
	Log	X	Alarm	X	Alarm light Off
Consequence					
Elimination	When sensor value becomes valid, it is marked as inactive in alarm list and may then be deleted. Value must be valid for 60 sec. to set alarm inactive.				
Log data	Parm 1	Parm 2	Parm 3	Parm 4	Parm 5
	Active/Inactive				



306	High press switch					Warning
Description	High pressure switch is active					
Cause	Discharge pressure is too high and the high pressure switch off					
Trouble shooting	<p>Possible causes:</p> <ul style="list-style-type: none"> • High pressure due to <ul style="list-style-type: none"> – Ambient temperature is over spec. limit +50°C (+122°F) – Manual valve after compressor closed – HP pipe damaged – Condenser fan motor is not running – Condenser blocked • High pressure switch or cable is defective • Wrong pressure transmitter in relation to controller settings • Pressure transmitter defective • X15 cable is defective • Main controller defective <p>Accompanied alarms:</p> <ul style="list-style-type: none"> • AL 604 may be or get active. <p>Trouble shooting:</p> <ol style="list-style-type: none"> 1) The unit uses cooling refrigerant R134a and it is very difficult to operate at temperatures above specification. The unit needs cooler surroundings, better ventilation or water cooling. 2) If the pressure rises very quickly after start of the compressor, check that the valve after the compressor (discharge side) is not closed or only partially open. Make sure valve is fully open. 3) Check that there are no damages to the pipes after the compressor. Repair if they are damaged and check cooling liquid level (R134a). 4) Check that there are no alarm for the condenser fan motor, AL 402, AL 426 and that, the fan is rotating and that the condenser is not blocked for airflow. 5) If condenser is blocked, clean the condenser to secure any residues is removed. <p>Disconnect the cable for high pressure switch on the main controller according to the wiring schematics inside the control cabinet.</p> <ol style="list-style-type: none"> 6) Measure the voltage between the two connectors for the high pressure switch on the connector PCB. If the voltage is below 15 V AC, replace the main controller. 7) Check the cable (measure the resistance in the cable). If the cable is defective, replace cable and high pressure switch. 8) Mount the cable for the high pressure switch again. If this alarm is still active on the display, replace the main controller. 9) Look in display to see if pressure transmitter is according to settings (see "Configuration:" p. 48 (F08)) and set controller according to transmitter. 10) If pressure transmitter type is correct, perform troubleshooting for AL 203. 					
Criteria	Pressure is above high pressure switch safety limit. Cut – out: 22.5 BarE ± 0.7 Bar (326.3 psi ± 10.2 psi), Cut – in: 15.9 BarE ± 0.7 Bar (230.6 psi ± 10.2 psi).					
Controller action	Frequency controller is stopped and unit stops					
	Log	X	Alarm	X	Alarm light	Off
Consequence	Unit stops					
Elimination	Unit restarts after 5 min. When sensor value becomes valid, it is marked as inactive in alarm list and may then be deleted. Value must be valid for 60 sec. to set alarm inactive.					
Log data	Parm 1	Parm 2	Parm 3	Parm 4	Parm 5	
	Active/Inactive	Pdis 6 sec	0	Psuc 6 sec	FCtemp 6 sec	



314	Replace CO2 sensor					Alarm
Description	Replace CO2 sensor					
Cause	CO2 measurement after calibration (PTI) is out of range					
Trouble shooting	<p><u>Possible causes:</u></p> <ul style="list-style-type: none"> Sensor measurement out of range from last PTI (calibration) and CA/AV+ is active <p><u>Accompanied alarms:</u></p> <ul style="list-style-type: none"> Replacing AL 316 when CA/AV+ is active. Al 316 visible in log <p><u>Trouble shooting:</u></p> <p>1) Replace CO2 sensor with new</p>					
Criteria	After a passed PTI test, the CO2 measurement value should be between -0,26% and 0,34%.					
Controller action	Alarm					
	Log	X	Alarm	X	Alarm light	On
Consequence	None					
Elimination	When sensor is replaced, alarm is marked as inactive in alarm list and may then be deleted					
Log data	Parm 1	Parm 2	Parm 3	Parm 4	Parm 5	
	CO2 meas	0	0	0	0	

315	Replace O2 sensor					Alarm
Description	Replace O2 sensor					
Cause	O2 measurement after calibration (PTI) is out of range					
Trouble shooting	<p><u>Possible causes:</u></p> <ul style="list-style-type: none"> Sensor measurement out of range from last PTI (calibration) and CA/AV+ is active <p><u>Accompanied alarms:</u></p> <ul style="list-style-type: none"> Replacing AL 317 when CA/AV+ is active. Al 317 visible in log <p><u>Trouble shooting:</u></p> <p>1) Replace O2 sensor with new</p>					
Criteria	After a passed PTI test, the O2 measurement value should be between 20,4% & 21,4%					
Controller action	Alarm					
	Log	X	Alarm	X	Alarm light	On
Consequence	None					
Elimination	When sensor is replaced, alarm is marked as inactive in alarm list and may then be deleted					
Log data	Parm 1	Parm 2	Parm 3	Parm 4	Parm 5	
	O2 meas	0	0	0	0	



316	Replace CO2 sensor					Warning
Description	Replace CO2 sensor					
Cause	CO2 measurement after calibration (PTI) is out of range					
Trouble shooting	<p><u>Possible causes:</u></p> <ul style="list-style-type: none"> Sensor measurement out of range from last PTI (calibration) and CA/AV+ is active <p><u>Accompanied alarms:</u></p> <ul style="list-style-type: none"> Replacing AL 314 when CA/AV+ is inactive. AI 314 visible in log <p><u>Trouble shooting:</u></p> <p>1) Replace CO2 sensor with new</p>					
Criteria	After a passed PTI test, the CO2 measurement value should be between -0,26% and 0,34%.					
Controller action	None					
	Log	X	Alarm	X	Alarm light	Off
Consequence	None					
Elimination	When sensor is replaced, alarm is marked as inactive in alarm list and may then be deleted					
Log data	Parm 1	Parm 2	Parm 3	Parm 4	Parm 5	
	CO2 meas	0	0	0	0	

317	Replace O2 sensor					Warning
Description	Replace O2 sensor					
Cause	O2 measurement after calibration (PTI) is out of range					
Trouble shooting	<p><u>Possible causes:</u></p> <ul style="list-style-type: none"> Sensor measurement out of range from last PTI (calibration) and CA/AV+ is active <p><u>Accompanied alarms:</u></p> <ul style="list-style-type: none"> Replacing AL 315 when CA/AV+ is inactive. AI 315 visible in log <p><u>Trouble shooting:</u></p> <p>1) Replace O2 sensor with new</p>					
Criteria	After a passed PTI test, the O2 measurement value should be between 20,4% & 21,4%					
Controller action	None					
	Log	X	Alarm	X	Alarm light	Off
Consequence	None					
Elimination	When sensor is replaced, alarm is marked as inactive in alarm list and may then be deleted					
Log data	Parm 1	Parm 2	Parm 3	Parm 4	Parm 5	
	O2 meas	0	0	0	0	



Power Alarms (AL 4XX)

400	Mevap 1 overheat				Warning	
Description	Evaporator Motor 1 Overheat					
Cause	Indication of an overheated motor or a loose thermistor cable connection					
Trouble shooting	<p><u>Possible causes:</u></p> <ul style="list-style-type: none"> • Evaporator motor 1 defective. • Cable for measuring evaporator motor 1 overheat defective. • Main controller defective. • Damage on cable for Mevap 1 <p><u>Accompanied alarms:</u></p> <ul style="list-style-type: none"> • N/A. <p><u>Trouble shooting:</u></p> <ol style="list-style-type: none"> 1) Turn off unit! Open inspection hatch and see if the evaporator fan can turn freely. If it cannot turn, remove ice or replace the motor. If the motor is hot, it may be overloaded and jammed or defective. 2) If the cable for Mevap1 by inspection is defective, if unable to repair cable, replace it. 3) Disconnect the wires for Mevap1 on the main controller according to the wiring schematics inside the control cabinet. 4) Measure the resistance in the cable. If the resistance is more than 1 MΩ, the cable or the motor is defective and should be replaced. If the resistance is less than (<) 5 kΩ, the cable and motor should be OK. 5) Turn unit on again. Measure the voltage across the connector for Mevap1. It should be between 4.80 V DC and 5.20 V DC. <ol style="list-style-type: none"> a) If the voltage is inside the above range, connect cable again. Measure the voltage across the thermistor and check the voltage. If the voltage is less than (<) 2.5 V DC, the measurement is OK. If the alarm after 30 sec. is still active in the display, the main controller is defective - replace main controller. b) If the voltage is outside the range, main controller is defective or another error might affect the voltage. Check other alarms before replacing main controller. 					
Criteria	Value above high alarm limit 10K Ohm.					
Controller action	Both evaporator fan motors stop					
	Log	X	Alarm	X	Alarm light	Off
Consequence	Air circulation in container stops causing unit to stop					
Elimination	When overheating disappears, alarm will be marked as inactive in alarm list and may then be deleted. Control is again released, but fan motors will only be allowed to operate at low speed for the first 5 min. If the error does not reoccur, problem will be considered solved and evaporator fan high speed is again released.					
Log data	Parm 1	Parm 2	Parm 3	Parm 4	Parm 5	
	Active/Inactive		High limit	Present		



401	Mevap 2 overheat					Warning
Description	Evaporator Motor 2 Overheat					
Cause	Indication of an overheated motor or a loose thermistor cable connection					
Trouble shooting	<p><u>Possible causes:</u></p> <ul style="list-style-type: none"> • Evaporator motor 2 defective. • Cable for measuring evaporator motor 2 overheat defective. • Main controller defective. • Damage on cable for Mevap 2 <p><u>Accompanied alarms:</u></p> <ul style="list-style-type: none"> • N/A. <p><u>Trouble shooting:</u></p> <ol style="list-style-type: none"> 1) Turn off unit! Open inspection hatch and see if the evaporator fan can turn freely. If it cannot turn, remove ice or replace the motor. If the motor is hot, it may be overloaded and jammed or defective. 2) If the cable for Mevap2 by inspection is defective, if unable to repair cable, replace it. 3) Disconnect the wires for Mevap2 on the main controller according to the wiring schematics inside the control cabinet. 4) Measure the resistance in the cable. If the resistance is more than 1 MΩ, the cable or the motor is defective and should be replaced. If the resistance is less than (<) 5 kΩ, the cable and motor should be OK. 5) Turn unit on again. Measure the voltage across the connector for Mevap2. It should be between 4.80 V DC and 5.20 V DC. <ol style="list-style-type: none"> a) If the voltage is inside the above range, connect sensor again. Measure the voltage across the thermistor and check the voltage. If the voltage is less than (<) 2.5 V DC, the measurement is OK. If the alarm after 30 sec. is still active on the display, the main controller is defective - replace main controller. b) If the voltage is outside the range, main controller is defective or another error might affect the voltage. Check other alarms before replacing main controller. 					
Criteria	Value above high alarm limit 10K Ohm.					
Controller action	Both evaporator fan motors are stopped					
	Log	X	Alarm	X	Alarm light	Off
Consequence	Air circulation in container stops causing unit to stop					
Elimination	When overheating ceases, alarm will be marked as inactive in alarm list and may then be deleted. Control is again released but fan motors will only be allowed to operate at low speed for the first 5 min. If error does not reoccur, problem will be considered solved and evaporator fan high speed is again released.					
Log data	Parm 1	Parm 2	Parm 3	Parm 4	Parm 5	
	Active/Inactive		High limit	Present		



402	Mcond overheat	Warning
Description	Condenser Motor Overheat	
Cause	Indication of an overheated motor or a loose thermistor cable connection	
Trouble shooting	<p><u>Possible causes:</u></p> <ul style="list-style-type: none"> • Condenser motor defective. • Cable for measuring condenser motor overheat defective. • Main controller defective. <p><u>Accompanied alarms:</u></p> <ul style="list-style-type: none"> • N/A. <p><u>Trouble shooting:</u></p> <ol style="list-style-type: none"> 1) Turn off unit! See if the condenser fan can turn freely. If it cannot turn, replace the motor. If the motor is hot, it may be overloaded and jammed or defective. 2) If the cable for McondOH by inspection is defective, if unable to repair cable, replace it. 3) Disconnect the cable for Mcond on the main controller according to the wiring schematics inside the control cabinet. 4) Measure the resistance in the cable. If the resistance is more than 1 MΩ, the cable or the motor is defective and should be replaced. If the resistance is less than (<) 5 kΩ, the cable and motor should be OK. 5) Turn unit on again. Measure the voltage across the connector for Mcond. It should be between 4.80 V DC and 5.20 V DC. <ol style="list-style-type: none"> a) If the voltage is inside the above range, connect sensor again. Measure the voltage across the thermistor and check the voltage. If the voltage is less than (<) 2.5 V DC, the measurement is OK. If the alarm after 30 sec. is still active in the display, the main controller is defective - replace the main controller. b) If the voltage is outside the range, main controller is defective or another error might affect the voltage. Check other alarms before replacing main controller. 	
Criteria	Value above top alarm limit 10K Ohm	
Controller action	Condenser fan motor is stopped	
	Log	X
	Alarm	X
	Alarm light	Off
Consequence	Air circulation in container stops causing unit to stop	
Elimination	When overheating disappears, alarm will be marked as inactive in alarm list and may then be deleted. Control is again released, but fan motor will only be allowed to operate at low speed for the first 5 min. If the error does not reoccur, problem will be considered solved and condenser fan high speed is again released.	
Log data	Parm 1	Parm 2
	Active/Inactive	High limit
		Present



410	Unstable supply					Fatal
Description	Unit power supply is unstable					
Cause	A drop out in the power supply has occurred					
Trouble shooting	<p><u>Possible causes:</u></p> <ul style="list-style-type: none"> Inadequate power supply and or bad genset <p><u>Accompanied alarms:</u></p> <ul style="list-style-type: none"> AL 414, 415, 416, 417, 418, 419, 424, 425, 426, 427, 428 and 429 <p><u>Trouble shooting:</u></p> <ol style="list-style-type: none"> If there are other active alarms, check these first. Clear these alarms first using their trouble shooting. If the unit is supplied with a genset, try to replace the genset first and see if error still persists. If the unit is supplied from a stable power grid and the problem still persists, replace main controller module. 					
Criteria	The main controller measures the zero crosses on the supply voltage, if a drop out of more than on period occurs, the alarm is triggered.					
Controller action	Controller breaks supply after 5 sec. After 30 sec. the unit restarts with a normal startup procedure					
	Log	X	Alarm	X	Alarm light	On
Consequence	Unit stops					
Elimination	Solve the issue according to Trouble Shooting guidelines.					
Log data	Parm 1	Parm 2	Parm 3	Parm 4	Parm 5	
	Active/Inactive	U1-2	U2-3	U1-3	Freq	

411	Unit over current					Log
Description	Unit Over current					
Cause	Indication of short circuit					
Trouble shooting	<p><u>Possible causes:</u></p> <ul style="list-style-type: none"> The unit is using too much power. <p><u>Accompanied alarms:</u></p> <ul style="list-style-type: none"> N/A. <p><u>Trouble shooting:</u></p> <ol style="list-style-type: none"> The voltage may have been too low for too long. Check for loose connections. When cargo is unloaded, run a PTI test and see if one of the motors or heater is using too much power. Check power cables for short circuits and damages. Check cables for heaters and motors for short circuits and damages. 					
Criteria	Maximum current consumption has been exceeded					
Controller action	Controller breaks supply					
	Log	X	Alarm		Alarm light	Off
Consequence	Unit stops					
Elimination						
Log data	Parm 1	Parm 2	Parm 3	Parm 4	Parm 5	
	Active/Inactive	Phase no.	Present	Limit		

This alarm is used for service purposes, the fuses are protecting the unit



414	U1-2 over voltage					Fatal Alarm
Description	U1-2 over voltage					
Cause	Indication of error in container supply voltage between phases 1 and 2					
Trouble shooting	<p>Possible causes:</p> <ul style="list-style-type: none"> The unit is supplied with a voltage above specified level. <p>Accompanied alarms:</p> <ul style="list-style-type: none"> N/A. <p>Trouble shooting:</p> <ol style="list-style-type: none"> Measure the voltage applied to the unit. Apply correct voltage to the unit. <p>The FC will be destroyed if it is running at a too high voltage.</p> <ol style="list-style-type: none"> Measure the actual voltage and compare with the value in the display. If the measurement differs the power module PCB may be defective. Replace or bypass power module PCB by pressing  selecting configuration then phase direction and then cw. If condenser fan rotates in the wrong direction, choose ccw. This action is to be performed at every unit start up 					
Criteria	Value above top alarm limit 525 Volt					
Controller action	Controller breaks supply after 60 sec. After 30 sec. the unit restarts with a normal startup procedure.					
	Log	X	Alarm	X	Alarm light	Quick flash
Consequence	Unit stops					
Elimination	Alarm will be marked as inactive if another phase voltage measuring is below limit. It may then be deleted.					
Log data	Parm 1	Parm 2	Parm 3	Parm 4	Parm 5	
	Active/Inactive	Low limit	High limit	Voltage	0	

415	U2-3 over voltage					Fatal Alarm
Description	U2-3 over voltage					
Cause	Indication of error in container supply voltage between phases 2 and 3					
Trouble shooting	For trouble shooting see AL 414					
Criteria	Value above top alarm limit 525 Volt					
Controller action	Controller breaks supply after 60 sec. After 30 sec. the unit restarts with a normal startup procedure.					
	Log	X	Alarm	X	Alarm light	Quick flash
Consequence	Unit stops					
Elimination	Alarm will be marked as inactive if another phase voltage measuring is below limit. It may then be deleted.					
Log data	Parm 1	Parm 2	Parm 3	Parm 4	Parm 5	
	Active/Inactive	Low limit	High limit	Voltage	0	



416	U1-3 over voltage					Fatal Alarm
Description	U1-3 over voltage					
Cause	Indication of error in container supply voltage between phases 1 and 3					
Trouble shooting	For trouble shooting see AL 414					
Criteria	Value above top alarm limit 525 Volt					
Controller action	Controller breaks supply after 60 sec. After 30 sec. the unit restarts with a normal startup procedure.					
	Log	X	Alarm	X	Alarm light	Quick flash
Consequence	Unit stops					
Elimination	Alarm will be marked as inactive if another phase voltage measuring is below limit. It may then be deleted.					
Log data	Parm 1	Parm 2	Parm 3	Parm 4	Parm 5	
	Active/Inactive	Low limit	High limit	Voltage	0	

417	U1-2 under voltage					Fatal Alarm
Description	U1-2 under voltage					
Cause	Indication of error in container supply voltage between phases 1 and 2					
Trouble shooting	<u>Possible causes:</u>					
	<ul style="list-style-type: none"> • The unit is supplied with a voltage below specified level. • Defective Power module PCB 					
	<u>Accompanied alarms:</u>					
	<ul style="list-style-type: none"> • N/A. 					
Trouble shooting	<u>Trouble shooting:</u>					
	1) Measure the voltage applied to the unit.					
	2) Apply correct voltage to the unit.					
	The FC will not be able to maintain stable speed of the compressor motor due to a too low voltage and therefore the unit will make a restart.					
Trouble shooting	3) Measure the actual voltage and compare with the value in the display. If the measurement differs the power module PCB may be defective. Replace or bypass power module PCB by pressing  selecting configuration then phase direction and then cw. If condenser fan rotates in the wrong direction, choose ccw. This action is to be performed at every unit start up.					
	Criteria					
	Value below low alarm limit 335 Volt					
	Controller action	Controller breaks supply after 60 sec. After 30 sec. the unit restarts with a normal startup procedure.				
Log		X	Alarm	X	Alarm light	Off
Consequence	Unit stops					
Elimination	Alarm will be marked as inactive if another phase voltage measuring is above limit. It may then be deleted.					
Log data	Parm 1	Parm 2	Parm 3	Parm 4	Parm 5	
	Active/Inactive	Low limit	High limit	Voltage	0	



418	U2-3 under voltage					Fatal Alarm
Description	U2-3 under voltage					
Cause	Indication of error in container supply voltage between phases 2 and 3					
Trouble shooting	See trouble shooting for AL 417					
Criteria	Value below low alarm limit 335 Volt					
Controller action	Controller breaks supply after 60 sec. After 30 sec. the unit restarts with a normal startup procedure.					
	Log	X	Alarm	X	Alarm light	Off
Consequence	Unit stops					
Elimination	Alarm will be marked as inactive if another phase voltage measuring is above limit. It may then be deleted.					
Log data	Parm 1	Parm 2	Parm 3	Parm 4	Parm 5	
	Active/Inactive	Low limit	High limit	Voltage	0	

419	U1-3 under voltage					Fatal Alarm
Description	U1-3 under voltage					
Cause	Indication of error in container supply voltage between phases 1 and 3					
Trouble shooting	See trouble shooting for AL 417					
Criteria	Value below low alarm limit 335 Volt					
Controller action	Controller breaks supply after 60 sec. After 30 sec. the unit restarts with a normal startup procedure.					
	Log	X	Alarm	X	Alarm light	Off
Consequence	Unit stops					
Elimination	Alarm will be marked as inactive if another phase voltage measuring is above limit. It may then be deleted.					
Log data	Parm 1	Parm 2	Parm 3	Parm 4	Parm 5	
	Active/Inactive	Low limit	High limit	Voltage	0	



420	I1 over current					Log
Description	I1 over current					
Cause	Indication of short circuit in electric installations of Star Cool unit					
Trouble shooting	<p><u>Possible causes:</u></p> <ul style="list-style-type: none"> The unit is using too much power on one phase. Defective Power module PCB <p><u>Accompanied alarms:</u></p> <ul style="list-style-type: none"> N/A. <p><u>Trouble shooting:</u></p> <ol style="list-style-type: none"> The voltage may have been too low for too long. Check power cables for short circuits and damages. Check cables for heaters and motors for short circuits and damages. Measure the actual current and compare with the value in the display. If the measurement differs, the power module PCB may be defective. Replace or bypass power module PCB by pressing  selecting configuration then phase direction and then cw. If condenser fan rotates in the wrong direction, choose ccw. This action is to be performed at every unit start up 					
Criteria	Value above upper alarm limit 20 Amp					
Controller action	None					
	Log	X	Alarm		Alarm light	Off
Consequence	Unit stops					
Elimination						
Log data	Parm 1	Parm 2	Parm 3	Parm 4	Parm 5	
	Active/Inactive		High limit	Present	0	

This alarm is used for service purposes. The fuses are protecting the unit

421	I2 over current					Log
Description	I2 over current					
Cause	Indication of short circuit in electric installations of Star Cool unit					
Trouble shooting	<u>See trouble shooting for AL 420</u>					
Criteria	Value above upper alarm limit 20 Amp					
Controller action	None					
	Log	X	Alarm		Alarm light	Off
Consequence	Unit stops					
Elimination						
Log data	Parm 1	Parm 2	Parm 3	Parm 4	Parm 5	
	Active/Inactive		High limit	Present	0	

This alarm is used for service purposes. The fuses are protecting the unit



422	I3 over current					Log
Description	I3 Over current					
Cause	Indication of short circuit in electric installations of Star Cool unit					
Trouble shooting	<u>See trouble shooting for AL 420</u>					
Criteria	Value above upper alarm limit 20 Amp					
Controller action	None					
	Log	X	Alarm		Alarm light	Off
Consequence	Unit stops					
Elimination						
Log data	Parm 1	Parm 2	Parm 3	Parm 4	Parm 5	
	Active/Inactive		High limit	Present	0	

This alarm is used for service purposes. The fuses are protecting the unit

423	No phase direction					Fatal Alarm
Description	Phase direction not detectable					
Cause	Phases may be lacking or there may be extremely high noise in one or more phases in the detection moment					
Trouble shooting	<u>Possible causes:</u>					
	<ul style="list-style-type: none"> • The unit is supplied with an unstable voltage. • The power frequency is out of specified range. • Defective Power module PCB 					
	<u>Accompanied alarms:</u>					
	<ul style="list-style-type: none"> • AL 424 may also be active. 					
Trouble shooting	<u>Trouble shooting:</u>					
	1) Check if voltage on all 3 phases is within specified range.					
	2) Verify that power frequency is within specified range.					
	3) Check/replace power module PCB.					
Trouble shooting	4) If 1) to 6) are OK, then replace the main controller or set the correct phase direction on the Configuration menu F05 to clockwise or counterclockwise .					
	Criteria					
	Impossible to detect phase sequence in power supply					
	Controller action	Controller breaks supply				
Log		X	Alarm	X	Alarm light	Quick flash
Consequence	Unit stops					
Elimination	Alarm will be marked as inactive in alarm list when phase sequence can be established. Alarm may then be deleted.					
Log data	Parm 1	Parm 2	Parm 3	Parm 4	Parm 5	
	Active/Inactive	No. of CW	No. of CCW	Min. no. OK		



424	Power frequency					Log
Description	Phase frequency error					
Cause	Indication of error on StarCool unit power supply					
Trouble shooting	<p><u>Possible causes:</u></p> <ul style="list-style-type: none"> The unit is supplied with an unstable voltage. The power frequency is out of specified range. <p><u>Accompanied alarms:</u></p> <ul style="list-style-type: none"> AL 423 may also be active. <p><u>Trouble shooting:</u></p> <ol style="list-style-type: none"> Check if voltage on all 3 phases is within specified range. Verify that all 3 phases are applied to the unit and for example not just 2 phases. Verify that power frequency is within specified range. Apply correct voltage to the unit 					
Criteria	Value out of limits. Power frequency must be between 47.5 Hz and 62.5 Hz					
Controller action	None					
	Log	X	Alarm		Alarm light	Off
Consequence	At very low frequencies this error will lead to AL 423. Otherwise, normal operation can take place; The measuring system, however, will perform badly					
Elimination	Power frequency within range again					
Log data	Parm 1	Parm 2	Parm 3	Parm 4	Parm 5	
	Active/Inactive	Sample U1	Sample U2	Sample U3		

425	Frequency too high					Warning
Description	Power Frequency Too High Warning					
Cause	Power generator adjusted to too high frequency					
Trouble shooting	<p><u>Possible causes:</u></p> <ul style="list-style-type: none"> The power frequency is out of specified range. <p><u>Accompanied alarms:</u></p> <ul style="list-style-type: none"> AL 423 may also be active. <p><u>Trouble shooting:</u></p> <ol style="list-style-type: none"> Adjust the frequency of the power generator to a lower frequency. Verify that power frequency is within specified range. Apply correct voltage to the unit 					
Criteria	Power frequency above 66 Hz					
Controller action	Mcond, Mevap1 and Mevap2 fan motors forced to low speed					
	Log	X	Alarm	X	Alarm light	Off
Consequence	Reduced capacity of unit					
Elimination	Power frequency within range again					
Log data	Parm 1	Parm 2	Parm 3	Parm 4	Parm 5	
	Active/Inactive	Frequency				



426	Frequency too high					Alarm
Description	Power Frequency Too High Alarm					
Cause	Power generator adjusted to too high frequency					
Trouble shooting	<p><u>Possible causes:</u></p> <ul style="list-style-type: none"> The power frequency is out of specified range. <p><u>Accompanied alarms:</u></p> <ul style="list-style-type: none"> AL 423 or AL 425 may also be active. <p><u>Trouble shooting:</u></p> <ol style="list-style-type: none"> Adjust the frequency of the power generator to a lower frequency. Verify that power frequency is within specified range. Apply correct voltage to the unit. 					
Criteria	Power frequency above 66 Hz for 5 min. or above 70 Hz					
Controller action	Mcond, Mevap1 and Mevap2 fan motors forced to low speed					
	Log	X	Alarm	X	Alarm light	Off
Consequence	Reduced capacity of unit					
Elimination	Power frequency within range again					
Log data	Parm 1	Parm 2	Parm 3	Parm 4	Parm 5	
	Active/Inactive	Frequency				

427	(Voltage/freq.) U/f ratio low					Alarm
Description	Bad power supply - over loaded / under supplied					
Cause	Power generator adjusted to too high frequency compared to supply voltage					
Trouble shooting	<p><u>Possible causes:</u></p> <ul style="list-style-type: none"> Overload of power supply Bad connection in plug <p><u>Accompanied alarms:</u></p> <ul style="list-style-type: none"> 429 <p><u>Trouble shooting:</u></p> <ol style="list-style-type: none"> Find better cable and or plug Find failure in the supply system If no AL 429, watch the unit more often 					
Criteria	U_{mean} is less than ($<$) $40 + 6.2 * \text{frequency}$ $U_{mean} = (U1-2 + U2-3 + U1-3)/3$					
Controller action	None					
	Log	X	Alarm	X	Alarm light	Slow flash
Consequence	None					
Elimination	Alarm will be marked as inactive in alarm list when proper supply is established. Alarm may then be deleted.					
Log data	Parm 1	Parm 2	Parm 3	Parm 4	Parm 5	
	Active/Inactive	U1-2	U2-3	U1-3	NetFreq	



428	(Voltage/freq.) U/f ratio high					Alarm
Description	Bad power supply - voltage regulation out of order.					
Cause	Power generator adjusted to too high voltage					
Trouble shooting	<p><u>Possible causes:</u></p> <ul style="list-style-type: none"> Failure in generator voltage control <p><u>Accompanied alarms:</u></p> <ul style="list-style-type: none"> AL 429 <p><u>Trouble shooting:</u></p> <ol style="list-style-type: none"> Find a better supply If no AL 429, watch the unit more often 					
Criteria	Umean is more than (>) $140 + 6.2 * \text{frequency}$ $U_{\text{mean}} = (U_{1-2} + U_{2-3} + U_{1-3})/3$					
Controller action	None					
	Log	X	Alarm	X	Alarm light	Slow flash
Consequence	None					
Elimination	Alarm will be marked as inactive in alarm list when proper supply is established. Alarm may then be deleted.					
Log data	Parm 1	Parm 2	Parm 3	Parm 4	Parm 5	
	Active/Inactive	U1-2	U2-3	U1-3	NetFreq	

429	(Voltage/freq.) U/f ratio					Fatal alarm
Description	Bad power supply					
Cause	See AL 427 and AL 428					
Trouble shooting	<p><u>Possible causes:</u></p> <ul style="list-style-type: none"> See AL 427 and AL 428 <p><u>Accompanied alarms:</u></p> <ul style="list-style-type: none"> AL 427 and AL 428 <p><u>Trouble shooting:</u></p> <ol style="list-style-type: none"> See AL 427 and AL 428 					
Criteria	Lower limit: Umean is less than (<) $23 + 6.2 * \text{frequency}$ Upper limit: Umean is more than (>) $155 + 6.2 * \text{frequency}$ $U_{\text{mean}} = (U_{1-2} + U_{2-3} + U_{1-3})/3$					
Controller action	All contacts are released					
	Log	X	Alarm	X	Alarm light	Quick flash
Consequence	All fans forced into Low Speed					
Elimination	Alarm will be marked as inactive in alarm list when proper supply is established. Alarm may then be deleted.					
Log data	Parm 1	Parm 2	Parm 3	Parm 4	Parm 5	
		U1-2	U2-3	U1-3	NetFreq	



430	Cpr connection					Alarm
Description	Power Cable From FC to Compressor is Faulty					
Cause	Indication of error with power cable between FC and compressor. The compressor is not using any power					
Trouble shooting	<p><u>Possible causes:</u></p> <ul style="list-style-type: none"> The power cable between the FC and the compressor motor is defective. The current measuring circuit in the FC is faulty. The compressor motor is damaged. <p><u>Accompanied alarms:</u></p> <ul style="list-style-type: none"> N/A. <p><u>Trouble shooting:</u></p> <ol style="list-style-type: none"> Check if voltage on all 3 phases is within specified range. Check that the power cable between the FC and the compressor motor is not damaged. Measure that the compressor motor is not damaged. The FC may be defective. 					
Criteria	FC is running but the current from the FC is below alarm limit					
Controller action	Mcond, Mevap1 and Mevap2 fan motors forced to low speed					
	Log	X	Alarm	X	Alarm light	Slow flash
Consequence	Controller will retry after 1 min.					
Elimination						
Log data	Parm 1	Parm 2	Parm 3	Parm 4	Parm 5	
	Active/Inactive	Fact	Idc			

Frequency Converter (FC) Alarms (AL 5XX)

For some of the alarms in this section, the FC may be faulty and must be replaced. For continuing operation until replacement is possible, the unit can be rewired and started for emergency operation: See "Emergency Operation" p. 51.

501	FC local control					Alarm
Description	FC setting in Local Mode					
Cause	Indication of FC set in the local control mode					
Trouble shooting	<p><u>Possible causes:</u></p> <ul style="list-style-type: none"> Cable FC-com periodically defective. Internal fault in the FC. Defective FC. <p><u>Accompanied alarms:</u></p> <ul style="list-style-type: none"> One or more AL 5XX may also be active. <p><u>Trouble shooting:</u></p> <ol style="list-style-type: none"> Check that the cable FC-com is connected and not damaged. If the alarm is then still active, the FC is defective and must be replaced. <p>If there is no FC replacement available, the unit can be rewired for emergency operation: See "Emergency Operation" p. 51</p>					
Criteria	FC in the local mode					



Controller action	Mcond, Mevap1 and Mevap2 fan motors forced to low speed					
	Log	X	Alarm	X	Alarm light	Slow flash
Consequence	Unit stop					
Elimination	Alarm will be marked as inactive in alarm list when local mode is reset on frequency converter. Alarm may then be deleted.					
Log data	Parm 1	Parm 2	Parm 3	Parm 4	Parm 5	
	Active/Inactive	Fact	IFC	Psuc	Pdis	

508	FC short circ	Alarm				
Description	FC Short Circuit Alarm					
Cause	Indication of defective "cable", compressor motor or FC					
Trouble shooting (A16)	<p><u>Possible causes:</u></p> <ul style="list-style-type: none"> • Short-circuit on the FC power output. • Damaged cable and/or plugs. <p><u>Accompanied alarms:</u></p> <ul style="list-style-type: none"> • One or more AL 5XX may also be active. <p><u>Trouble shooting:</u></p> <p>1) There is a short-circuit on the compressor motor (Mcpr) terminals or in the motor. Check the cable and replace if it is defective.</p> <p>2) The FC is defective and must be replaced.</p> <p>If there is no FC replacement available, the unit can be rewired for emergency operation: See "Emergency Operation" p. 51</p>					
Criteria	Short circuit in compressor or its terminals. Motor current has been above 40 Amp					
Controller action	FC shut-down					
	Log	X	Alarm	X	Alarm light	Slow flash
Consequence	Unit stop					
Elimination	Alarm will be marked as inactive in alarm list when reset by FC, and can then be deleted.					
Log data	Parm 1	Parm 2	Parm 3	Parm 4	Parm 5	
	Active/Inactive	Freq FC	I FC	Psuc	Pdis	

509	FC 24 V fault	Alarm
Description	FC Internal 24 V Supply Fault Alarm	
Cause	Indication of problems with FC	
Trouble shooting (A15)	<p><u>Possible causes:</u></p> <ul style="list-style-type: none"> • Internal fault in the FC. <p><u>Accompanied alarms:</u></p> <ul style="list-style-type: none"> • One or more AL 5XX may also be active. <p><u>Trouble shooting:</u></p> <p>1) Switch off the unit and wait 10 min. before switching on the unit again.</p> <p>2) If the alarm is then still active, the FC is defective and must be replaced.</p> <p>If there is no FC replacement available, the unit can be rewired for emergency operation: See "Emergency Operation" p. 51</p>	
Criteria	Internal 24 V supply error	



Controller action	FC shut-down					
	Log	X	Alarm	X	Alarm light	Slow flash
Consequence	Unit stop					
Elimination	Alarm will be marked as inactive in alarm list when reset by FC. Alarm may then be deleted.					
Log data	Parm 1	Parm 2	Parm 3	Parm 4	Parm 5	
	Active/Inactive	Freq FC	I FC	Psuc	Pdis	

510	FC earth fault	Alarm				
Description	FC Earth Fault Alarm					
Cause	Indication of problems with cable, compressor or FC					
Trouble shooting (A14)	<p><u>Possible causes:</u></p> <ul style="list-style-type: none"> Isolation damaged on the FC power output to the compressor. Defective FC. Damaged cable and/or plugs. <p><u>Accompanied alarms:</u></p> <ul style="list-style-type: none"> One or more AL 5XX may also be active. <p><u>Trouble shooting:</u></p> <ol style="list-style-type: none"> The power cable for the compressor motor (Mcpr) may have defective isolation. Check the cable and replace if it is defective. Measure resistance fase to ground (must be above 2 MΩ). The FC is defective and must be replaced. <p>If there is no FC replacement available, the unit can be rewired for emergency operation: See "Emergency Operation" p. 51</p>					
Criteria	Leakage current from outlets to ground of FC. Current 3 A for more than 10 µsec (0.00001 sec)					
Controller action	FC shut-down					
	Log	X	Alarm	X	Alarm light	Slow flash
Consequence	Unit stop					
Elimination	Alarm will be marked as inactive in alarm list when reset by FC. Alarm may then be deleted.					
Log data	Parm 1	Parm 2	Parm 3	Parm 4	Parm 5	
	Active/Inactive	Freq FC	I FC	Psuc	Pdis	



511	FC over cur					Alarm
Description	FC Overcurrent Alarm					
Cause	Indication of problems with compressor					
Trouble shooting (A13)	<p><u>Possible causes:</u></p> <ul style="list-style-type: none"> • The compressor motor draws too much current. • Defective FC. • Condenser blocked due to dirt and residue. <p><u>Accompanied alarms:</u></p> <ul style="list-style-type: none"> • One or more AL 5XX may also be active. Check also these alarms before replacing anything. <p><u>Trouble shooting:</u></p> <ol style="list-style-type: none"> 1) The compressor motor draws too much current from the FC. The motor may be jammed or defective. 2) Turn off unit and wait 10 min. before turning on the unit again. 3) If the compressor cannot run or runs very short time before this alarm comes again, the compressor is defective and must be replaced. 4) If the compressor can run several min. without alarm, the FC may be defective and must be replaced if the alarm comes again. If there is no FC replacement available, the unit can be rewired for emergency operation: See "Emergency Operation" p. 51 5) Clean condenser. 					
Criteria	FC overloaded. Current above 38 Amp for approx. 1 sec					
Controller action	FC shut-down					
	Log	X	Alarm	X	Alarm light	Slow flash
Consequence	Unit stop					
Elimination	Alarm will be marked as inactive in alarm list when reset by FC. Alarm may then be deleted					
Log data	Parm 1	Parm 2	Parm 3	Parm 4	Parm 5	
	Active/Inactive	Freq FC	I FC	Psuc	Pdis	

512	FC motor therm					Alarm
Description	FC- Compressor Motor Over temperature					
Cause	Indication of defective compressor or lack of oil					
Trouble shooting (A11)	<i>This alarm is not used at the moment</i>					
Criteria	Over temperature in compressor motor					
Controller action	FC shut-down					
	Log	X	Alarm	X	Alarm light	Slow flash
Consequence	Unit stop					
Elimination	Alarm will be marked as inactive in alarm list when reset by FC. Alarm may then be deleted					
Log data	Parm 1	Parm 2	Parm 3	Parm 4	Parm 5	
	Active/Inactive	Freq FC	I FC	Psuc	Pdis	



513	FC overload				Alarm	
Description	FC Overload Alarm					
Cause	Indication of problems with compressor					
Trouble shooting (A9)	<p><u>Possible causes:</u></p> <ul style="list-style-type: none"> • The FC cannot deliver enough power to the compressor. • Insufficient cooling for the FC. • Defective FC. <p><u>Accompanied alarms:</u></p> <ul style="list-style-type: none"> • AL 522 or AL 525 may also be active and should be checked first. <p><u>Trouble shooting:</u></p> <p>At very high ambient temperatures and very low setpoint temperatures, the FC may get too hot to generate enough power. Therefore it can be cooled by the refrigerant in the compressor.</p> <ol style="list-style-type: none"> 1) Check that all bolts fixing the FC to the compressor are properly fastened and nothing is jammed between the FC and the compressor. 2) Check the motor cable and replace it if it is defective. Fasten bolts properly for better cooling. 3) The compressor is wearing down and drawing increasingly power from the FC. Check other alarms if there have been more alarms from the FC. <ol style="list-style-type: none"> a. If the ambient temperature is not high, the compressor must be replaced. b. If the ambient temperature is high, the compressor and FC should be OK but close to operating limit. Monitor unit and see if problem continues. 4) The FC is defective and must be replaced. <p>If there is no FC replacement available, the unit can be rewired for emergency operation: See "Emergency Operation" p. 51</p>					
Criteria	FC overloaded. Current has been above 24 Amp for 20 sec.					
Controller action	FC shut-down					
	Log	X	Alarm	X	Alarm light	Slow flash
Consequence	Unit stop					
Elimination	The FC will be restarted after 10 min. Alarm will be marked as inactive in alarm list when reset by FC. Alarm may then be deleted.					
Log data	Parm 1	Parm 2	Parm 3	Parm 4	Parm 5	
	Active/Inactive	Freq FC	I FC	Psuc	Pdis	



514	FC under volt					Alarm
Description	FC Undervoltage Fault Alarm					
Cause	Indication of problems with supply voltage					
Trouble shooting (A9)	<p><u>Possible causes:</u></p> <ul style="list-style-type: none"> The FC is supplied with too low voltage for continuous operation. Defective FC. <p><u>Accompanied alarms:</u></p> <ul style="list-style-type: none"> AL 417, AL 418 or AL 419 may be active. <p><u>Trouble shooting:</u></p> <ol style="list-style-type: none"> Supply unit with correct power voltage according to specification. If voltage is within specification and not unstable, the FC may be defective and must be replaced. <p>If no FC replacement is available, the unit can be rewired for emergency operation: See "Emergency Operation" p. 51</p>					
Criteria	Supply voltage to FC is less than (<) 330 V AC with full load. The minimum voltage depends on the load of the FC.					
Controller action	FC shut-down					
	Log	X	Alarm	X	Alarm light	Slow flash
Consequence	Unit stop					
Elimination	Alarm will be marked as inactive in alarm list when reset by FC. Alarm may then be deleted.					
Log data	Parm 1	Parm 2	Parm 3	Parm 4	Parm 5	
	Active/Inactive	Freq FC	I FC	Psuc	Pdis	

515	FC over volt					Alarm
Description	FC Overvoltage Fault Alarm					
Cause	Indication of problems with supply voltage					
Trouble shooting (A7)	<p><u>Possible causes:</u></p> <ul style="list-style-type: none"> The FC is supplied with too high voltage for continuous operation. Defective FC. <p><u>Accompanied alarms:</u></p> <ul style="list-style-type: none"> AL 414, AL 415, AL 416 or AL 521 may be active. <p><u>Trouble shooting:</u></p> <ol style="list-style-type: none"> Supply unit with correct power voltage according to specification. The FC will be destroyed at too high voltages and is therefore being shut down. If voltage is within specification and not unstable, the FC may be defective and must be replaced. <p>If there is no FC replacement available, the unit can be rewired for emergency operation: See "Emergency Operation" p. 51</p>					
Criteria	Supply voltage of FC is more than (>) 550 V AC (800 V DC)					
Controller action	FC shut-down					
	Log	X	Alarm	X	Alarm light	Slow flash
Consequence	Unit stop					
Elimination	Alarm will be marked as inactive in alarm list when reset by FC. Alarm may then be deleted.					
Log data	Parm 1	Parm 2	Parm 3	Parm 4	Parm 5	
	Active/Inactive	Freq FC	I FC	Psuc	Pdis	



516	FC phase loss					Alarm
Description	FC Phase Loss Fault Alarm					
Cause	Indication of lack of phase or defective FC					
Trouble shooting (A4)	<p><u>Possible causes:</u></p> <ul style="list-style-type: none"> • One or more phases are not applied to the FC. • Unstable power supply (generator). • Defective FC. <p><u>Accompanied alarms:</u></p> <ul style="list-style-type: none"> • AL 523 • AL 417, AL 418, AL 419 may be active. <p><u>Trouble shooting:</u></p> <ol style="list-style-type: none"> 1) Verify that all 3 phases are present and voltage is correct. 2) Verify that voltage difference between the 3 phases is less than (<) 20 V AC. 3) If supply from the generator is unstable, adjust supply frequency to 50-55 Hz (see "Info Menu Viewing" p. 36 (I22)) to avoid self-oscillation. 4) If 1) to 4) do not solve the problem, then replace the FC. <p>If no FC replacement is available, the unit can be rewired for emergency operation.</p> <p>Remind to use oscilloscope for determination of unstable supply from generator caused by uneven torque on generator cylinders.</p>					
Criteria	FC cannot maintain DC filter voltage (or too much ripple in DC voltage). AL 523 has been active for more than 50 sec.					
Controller action	FC shut-down					
	Log	X	Alarm	X	Alarm light	Slow flash
Consequence	Unit stop					
Elimination	Alarm will be marked as inactive in alarm list when reset by FC. Alarm may then be deleted.					
Log data	Parm 1	Parm 2	Parm 3	Parm 4	Parm 5	
	Active/Inactive	Freq FC	I FC	Psuc	Pdis	



517	FC over temp					Alarm
Description	FC Overtemperature Fault Alarm					
Cause	Indication of problems with compressor or FC					
Trouble shooting (A36)	<p><u>Possible causes:</u></p> <ul style="list-style-type: none"> • FC operates at operating limits. • Insufficient cooling for the FC. • Defective FC. <p><u>Accompanied alarms:</u></p> <ul style="list-style-type: none"> • AL 522. <p><u>Trouble shooting:</u></p> <ol style="list-style-type: none"> 1) Verify that supply voltage is not too high. 2) Check that the FC is mounted and tightened correctly to the compressor. If the FC is mounted correctly, it should not be possible to insert an air gap gauge between FC and compressor. 3) Motor cable between FC and compressor may be jammed between FC and compressor. Cooling of FC is insufficient. If this alarm appears more than once: Dismount FC and check motor cable before mounting the FC again. Fasten bolts properly for better cooling. <p>If no FC replacement is available, the unit can be rewired for emergency operation: See "Emergency Operation" p. 51</p>					
Criteria	FC temperature exceeds +85°C (185°F), or above 78°C (172°F) for more than 15 min.					
Controller action	FC shut-down					
	Log	X	Alarm	X	Alarm light	Slow flash
Consequence	Unit stops and restarts when FC has cooled down					
Elimination	Alarm will be marked as inactive in alarm list when reset by FC. Alarm may then be deleted.					
Log data	Parm 1	Parm 2	Parm 3	Parm 4	Parm 5	
	Active/Inactive	Freq FC	I FC	Psuc	Pdis	



518	FC inrush				Alarm	
Description	FC Inrush Fault Alarm					
Cause	Indication of problems with supply voltage					
Trouble shooting (A36)	<p><u>Possible causes:</u></p> <ul style="list-style-type: none"> • The FC has had too many restarts within short time. • Manual activation of contactor (K8) on/off too many times. • Loose power connection for the FC. • Loose FC-com cable for communication with the FC. • Defective FC. <p><u>Accompanied alarms:</u></p> <ul style="list-style-type: none"> • There may be other AL 5XX alarms. <p><u>Trouble shooting:</u></p> <ol style="list-style-type: none"> 1) Verify that supply power for the unit is stable and within specification. 2) Check the FC-com cable for damages and loose connection. 3) Check supply power cables for the FC. 4) The FC may be defective and should be replaced. <p>If no FC replacement is available, the unit can be rewired for emergency operation: See "Emergency Operation" p. 51</p>					
Criteria	May occur if FC is activated too many times during a one minute period (the primary side). FC has been switched on/off more than twice within 1 minute.					
Controller action	FC shut-down					
	Log	X	Alarm	X	Alarm light	Slow flash
Consequence	Unit stops and restarts after some min.					
Elimination	Alarm will be marked as inactive in the alarm list when reset by the FC. The alarm may then be deleted.					
Log data	Parm 1	Parm 2	Parm 3	Parm 4	Parm 5	
	Active/Inactive	Freq FC	I FC	Psuc	Pdis	



519	FC internal					Warning
Description	Frequency converter high voltage fault warning					
Cause	Indication of problems with supply voltage					
Trouble shooting (W7)	<p><u>Possible causes:</u></p> <ul style="list-style-type: none"> Defective FC <p><u>Accompanied alarms:</u></p> <ul style="list-style-type: none"> There may be other AL 5XX alarms. <p><u>Trouble shooting:</u></p> <ol style="list-style-type: none"> The FC reports an internal failure. See if there should be other FC alarms (AL 5XX) and if they can be deleted first. Turn of the unit off for 10 min. and then start again. If this alarm becomes active again, the FC has a permanent internal fault and must be replaced. <p>If no FC replacement is available, the unit can be rewired for emergency operation: See "Emergency Operation" p. 51</p>					
Criteria	Internal error in FC					
Controller action	FC shut-down					
	Log	X	Alarm	X	Alarm light	Slow flash
Consequence	Unit stops					
Elimination	Alarm reset requires that supply voltage is disconnected from frequency converter. Alarm will be marked as inactive in alarm list when reset by FC. The alarm may then be deleted.					
Log data	Parm 1	Parm 2	Parm 3	Parm 4	Parm 5	
	Active/Inactive	Freq FC	I FC	Psuc	Pdis	

521	FC high volt					Warning
Description	FC High Voltage Fault Warning					
Cause	Indication of problems with supply voltage					
Trouble shooting (W7)	<p><u>Possible causes:</u></p> <ul style="list-style-type: none"> The unit is supplied with voltage above specification. Defective FC. <p><u>Accompanied alarms:</u></p> <ul style="list-style-type: none"> AL 515. <p><u>Trouble shooting:</u></p> <ol style="list-style-type: none"> Measure if the power voltage to the unit is within specification. Apply correct voltage. Turn the unit off for 10 min. and then start it again. If this alarm becomes active again, the FC has an internal fault and must be replaced. <p>If no FC replacement is available, the unit can be rewired for emergency operation: See "Emergency Operation" p. 51</p>					
Criteria	Supply voltage of FC has exceeded 535 V AC (760 V DC)					
Controller action	None					
	Log	X	Alarm	X	Alarm light	Off
Consequence	If not solved, this problem can cause FC to stop due to alarm 515					
Elimination	Warning will be marked as inactive in alarm list when reset by FC. Alarm may then be deleted.					



Log data	Parm 1	Parm 2	Parm 3	Parm 4	Parm 5
	Active/Inactive	Freq FC	I FC	Psuc	Pdis

522	FC high temp					Log
Description	FC Overtemperature Warning					
Cause	Indication of problems with compressor or FC					
Trouble shooting (W36)	<p><u>Possible causes:</u></p> <ul style="list-style-type: none"> • FC operates at operating limits. • Insufficient cooling for the FC. • Defective FC. <p><u>Accompanied alarms:</u></p> <ul style="list-style-type: none"> • None <p><u>Trouble shooting:</u></p> <ol style="list-style-type: none"> 1) Verify that supply voltage is not too high. 2) Check that the FC is mounted and tightened correctly to the compressor. If the FC is mounted correctly, it should not be possible to insert an air gap gauge between FC and compressor. 3) Motor cable between FC and compressor may be jammed between FC and compressor. Cooling of FC is insufficient. If this alarm appears more than once: Dismount FC and check motor cable before mounting the FC again. Fasten bolts properly for better cooling. <p>If no FC replacement is available, the unit can be rewired for emergency operation: See "Emergency Operation" p. 51</p>					
	Criteria	FC temperature has exceeded warning limit +78°C				
Controller action	None					
	Log	X	Alarm	X	Alarm light	Off
Consequence	If not solved, this problem can cause FC to stop due to alarm 517					
Elimination						
Log data	Parm 1	Parm 2	Parm 3	Parm 4	Parm 5	
	Active/Inactive	Freq FC	I FC	Psuc	Pdis	



523	FC phase loss					Warning
Description	FC Phase Loss Fault Warning					
Cause	Indication of defective FC or missing phase					
Trouble shooting (W36)	<p><u>Possible causes:</u></p> <ul style="list-style-type: none"> • One or more phases are not applied to the FC. • Unstable power supply (generator). • Defective FC. <p><u>Accompanied alarms:</u></p> <ul style="list-style-type: none"> • AL 417, AL 418, AL 419, AL 516 may be active. <p><u>Trouble shooting:</u></p> <ol style="list-style-type: none"> 1) Verify that voltage levels are the same for all 3 phases (difference in voltage below 14 V AC). 2) Supply unit with correct power voltage according to specification. 3) Replace the FC. <p>If no FC replacement is available, the unit can be rewired for emergency operation.</p>					
Criteria	More than 70 V diff. in min./max. for phases in power supply.					
Controller action	None					
	Log	X	Alarm	X	Alarm light	Off
Consequence	If not solved, this problem can cause FC to stop due to alarm 516					
Elimination	Warning will be marked as inactive in alarm list when reset by FC. Alarm may then be deleted.					
Log data	Parm 1	Parm 2	Parm 3	Parm 4	Parm 5	
	Active/Inactive	Freq FC	I FC	Psuc	Pdis	



524	FC current limit					Warning
Description	FC Current Limit Fault Warning					
Cause	Indication of problems with compressor. Error may be seen during pull-down					
Trouble shooting (A12)	<p><u>Possible causes:</u></p> <ul style="list-style-type: none"> • The compressor motor draws too much current. • Defective FC. <p><u>Accompanied alarms:</u></p> <ul style="list-style-type: none"> • One or more AL 5XX may also be active. Check these alarms also before replacing anything. <p><u>Trouble shooting:</u></p> <ol style="list-style-type: none"> 1) The compressor motor draws too much current from the FC. The motor may be jammed or defective. 2) Turn off unit and wait 10 min. before turning the unit on again. 4) If the compressor cannot run or runs very shortly before this alarm appears again, the compressor is defective and must be replaced. 5) If the compressor can run several min. without alarm, the FC may be defective and must be replaced if the alarm appears again. <p>If no FC replacement is available, the unit can be rewired for emergency operation: See "Emergency Operation" p. 51</p>					
Criteria	Motor current above 24 Amp for approx. 10 sec					
Controller action	None					
	Log	X	Alarm	X	Alarm light	Off
Consequence	If not solved, this problem can cause FC to stop due to alarm 511					
Elimination	Warning will be marked as inactive in alarm list when reset by FC. Alarm may then be deleted.					
Log data	Parm 1	Parm 2	Parm 3	Parm 4	Parm 5	
	Active/Inactive	Freq FC	I FC	Psuc	Pdis	



525	FC overload					Warning
Description	FC Overload Warning					
Cause	Indication of problems with compressor					
Trouble shooting (W9)	<p><u>Possible causes:</u></p> <ul style="list-style-type: none"> • The FC cannot supply enough power to the compressor. • Insufficient cooling for the FC. • Defective FC. <p><u>Accompanied alarms:</u></p> <ul style="list-style-type: none"> • AL 522 or AL 525 may also be active and should be checked first. <p><u>Trouble shooting:</u></p> <p>At very high ambient temperatures and very low setpoint temperatures, the FC may get too hot to generate enough power.</p> <ol style="list-style-type: none"> 1) Check that all bolts fixing the FC to the compressor are fastened and nothing is jammed between the FC and the compressor. 2) The power cable for the compressor motor (Mcpr) may have been mounted incorrectly and therefore the cooling contact between the FC and the compressor is not good enough. Check the motor cable and replace it if it is defective. Fasten bolts properly for better cooling. 3) The compressor is wearing down and drawing increasingly power from the FC. Check other alarms if there have been more alarms from the FC. <ol style="list-style-type: none"> a. If the ambient temperature is not high, the compressor must be replaced. b. If the ambient temperature is high, the compressor and FC should be OK but close to operating limit. Monitor unit and see if problem continues. 4) The FC is defective and must be replaced. <p>If no FC replacement is available, the unit can be rewired for emergency operation: See "Emergency Operation" p. 51</p>					
	Criteria	FC load has exceeded warning limit of 24 Amp				
Controller action	None					
	Log	X	Alarm	X	Alarm light	Off
Consequence	If not solved, this problem can cause FC to stop due to AL 513					
Elimination	Warning will be marked as inactive in alarm list when reset by FC. Alarm may then be deleted.					
Log data	Parm 1	Parm 2	Parm 3	Parm 4	Parm 5	
	Active/Inactive	Freq FC	I FC	Psuc	Pdis	



529	FC setup error					Warning
Description	FC Setup Warning					
Cause	The setup of the FC is rejected by the FC. Either communication problems or phase fault					
Trouble shooting (A37)	<p><u>Possible causes:</u></p> <ul style="list-style-type: none"> Defective FC. <p><u>Accompanied alarms:</u></p> <ul style="list-style-type: none"> There may be other AL 5XX alarms. <p><u>Trouble shooting:</u></p> <ol style="list-style-type: none"> The FC reports a failure in its factory setup data. See if there should be other FC alarms (AL 5XX) and if they can be removed first. Turn the unit off for 10 min. and then start it again. If this alarm becomes active again, the FC has a permanent internal fault and must be replaced. <p>If no FC replacement is available, the unit can be rewired for emergency operation: See "Emergency Operation" p. 51</p>					
Criteria	FC error reports its setup data					
Controller action	FC shut-down					
	Log	X	Alarm	X	Alarm light	Off
Consequence	The compressor will not start					
Elimination	Warning will be marked as inactive in alarm list when reset by FC. Alarm may then be deleted.					
Log data	Parm 1	Parm 2	Parm 3	Parm 4	Parm 5	
	Active/Inactive	Freq FC	I FC	Psuc	Pdis	

566	FC undefined alarm					Warning
Description	FC Undefined Alarm					
Cause	The FC has an undefined alarm/warning					
Trouble shooting	<p><u>Possible causes:</u></p> <ul style="list-style-type: none"> Defective FC. Defective power cable from FC to compressor motor. <p><u>Accompanied alarms:</u></p> <ul style="list-style-type: none"> There may be other AL 5XX alarms. <p><u>Trouble shooting:</u></p> <ol style="list-style-type: none"> The FC reports an undefined alarm/warning. See if there should be other FC alarms (AL 5XX) and if they can be deleted first. Turn the unit off for 10 min. and then start it again. If this alarm/warning becomes active again, the FC has a permanent internal fault and must be replaced. <p>If no FC replacement is available, the unit can be rewired for emergency operation: See "Emergency Operation" p. 51</p>					
Criteria	FC reports an undefined alarm					
Controller action	FC shut-down					
	Log	X	Alarm	X	Alarm light	Off
Consequence	Unit stop					



Elimination	Warning will be marked as inactive in alarm list when reset by FC. Alarm may then be deleted.				
Log data	Parm 1	Parm 2	Parm 3	Parm 4	Parm 5
	Active/Inactive	Freq FC	FC AL number	Psuc	Pdis

599	FC Trip Lock					Log
Description	The FC has tripped and stopped					
Cause	Alarm indicates problem with compressor or frequency controller					
Trouble shooting	<p><u>Possible causes:</u></p> <ul style="list-style-type: none"> • Other alarms have tripped (stopped) the FC. • Defective FC. <p><u>Accompanied alarms:</u></p> <ul style="list-style-type: none"> • There is another alarm(s), especially AL 5XX alarms. <p><u>Trouble shooting:</u></p> <ol style="list-style-type: none"> 1) The FC has tripped due to another AL 5XX alarm and then stopped. See if there should be other FC alarms (AL 5XX) and act accordingly to these. 2) Turn the unit off for 10 min. and then start it again. If this alarm becomes active again, the FC may have an internal fault and must be replaced. <p>If no FC replacement is available, the unit can be rewired for emergency operation: See "Emergency Operation" p. 51</p>					
Criteria	The FC has stopped due to an error and must be reset					
Controller action	FC is being reset					
	Log	X	Alarm		Alarm light	Off
Consequence	There is no cooling until the FC is ready again. The FC may need to cool down before restarting.					
Elimination						
Log data	Parm 1	Parm 2	Parm 3	Parm 4	Parm 5	
	Active/Inactive	Freq FC	I FC	Psuc	Pdis	



Operation Alarms (AL 6XX)

600	No control sensors					Fatal Alarm
Description	Supply Air Sensor 1, Supply Air Sensor 2, Return Air Sensor and Evaporator Sensor are all malfunctioning.					
Cause	Alarm indicates that all control-relevant sensors are defective or unreliable. See also "Temperature control" p. 19 and "Expansion valve control" p. 19					
Trouble shooting	<p><u>Possible causes:</u></p> <ul style="list-style-type: none"> Supply Air Sensor 1, Supply Air Sensor 2, Return Air Sensor and Evaporator Sensor are all malfunctioning. X22, X23, X24 and X25 cable is defective. Main controller defective. <p><u>Accompanied alarms:</u></p> <ul style="list-style-type: none"> AL 100 to AL 108. <p><u>Trouble shooting:</u></p> <ol style="list-style-type: none"> Verify all other sensor alarms AL 100 to AL 3XX and try to remove these alarms. If this alarm remains active, replace main controller. 					
Criteria	No valid control sensor values					
Controller action						
	Log	X	Alarm	X	Alarm light	Quick flash
Consequence	Unit stop					
Elimination	When one of the control sensor values enters into the valid area, it is again possible to control container temperature. For reliability reasons at least one of the control sensor values must be valid for 30 sec. before sensor may be used as control reference again.					
Log data	Parm 1	Parm 2	Parm 3	Parm 4	Parm 5	
	Active/Inactive					



601	No water cooling					Warning
Description	Water-cooling fault					
Cause	Lack of water-cooling					
Trouble shooting	<p><u>Possible causes:</u></p> <ul style="list-style-type: none"> • Water cooling selected and no water cooling active. • Insufficient water cooling capacity. • If program is chosen, warning can occur in units without water cooling. <p><u>Accompanied alarms:</u></p> <ul style="list-style-type: none"> • Other alarms might be active. <p><u>Trouble shooting:</u></p> <ol style="list-style-type: none"> 1) Verify that water cooling hoses are applied and water is running when selecting water cooling. 2) Verify that the water is not too hot and not able to be used for cooling the unit. 					
Criteria	Compressor discharge temperature exceeds limit for water-cooling, 60°C (+140°F) in more than 1 hour					
Controller action	Water-cooling is deactivated					
	Log	X	Alarm	X	Alarm light	Off
Consequence						
Elimination	Alarm will be marked as inactive in alarm list next time water-cooling is activated. Alarm may then be deleted.					
Log data	Parm 1	Parm 2	Parm 3	Parm 4	Parm 5	
	Active/Inactive	Tc	Wc off			



602	Tset unreachable					Alarm
Description	Tset Unreachable. <i>(Not implemented yet)</i>					
Cause	Indication of insufficient yield					
Trouble shooting	<p><u>Possible causes:</u></p> <ul style="list-style-type: none"> • Container doors are open or gasket defective. • Not enough refrigerant for the compressor. • Insufficient airflow though evaporator. • Insufficient airflow though condenser. • Defective hot gas valve (leaking). • Commodities are producing more heat than the cooling system can remove. <p><u>Accompanied alarms:</u></p> <ul style="list-style-type: none"> • Other alarms may be active. <p><u>Trouble shooting:</u></p> <p>The unit will continue the cooling but the next steps could be checked anyway.</p> <ol style="list-style-type: none"> 1) If other alarms – follow troubleshooting for these alarms. 2) Check container doors and gaskets. 3) Check if there is enough refrigerant in the unit. Check if the evaporator is filled with ice or dirt blocking air circulation. Check if evaporator motors can rotate. Watch fingers – turn unit off first! 4) Check if the condenser is filled with dirt and blocking air circulation. Check if condenser motor can rotate. Watch fingers – turn unit off first! 5) Check hot gas valve for leaking. Let the compressor run in manual for some time. Stop compressor and see if the suction pressure rises more than normal. If valve is defective, replace valve. 					
Criteria	Tset unreachable within time limit					
Controller action	None					
Consequence	If error is detected during PTI-test, PTI-test will fail					
Elimination	Alarm will be marked as inactive in alarm list when Tset is reached. Alarm may then be deleted.					
Log data	Parm 1	Parm 2	Parm 3	Parm 4	Parm 5	
	Active/Inactive					



603	In range fault					Fatal Alarm
Description	In-range fault					
Cause	Indication of insufficient yield or defective controller					
Trouble shooting	<p><u>Possible causes:</u></p> <ul style="list-style-type: none"> • Container doors are open or gasket defective. • Not enough refrigerant for the compressor. • Insufficient airflow though evaporator. • Insufficient airflow though condenser. • Defective hot gas valve (leaking). <p><u>Accompanied alarms:</u></p> <ul style="list-style-type: none"> • Other alarms may be active. <p><u>Trouble shooting:</u></p> <p>The unit will continue the cooling but the next steps could be checked anyway.</p> <ol style="list-style-type: none"> 1) If other alarms – follow troubleshooting for these alarms. 2) Check container doors and gaskets. 3) Check if there is enough refrigerant in the unit. Check if the evaporator is filled with ice or dirt blocking air circulation. Check if evaporator motors can rotate. Watch fingers – turn unit off first! 4) Check if the condenser is filled with dirt and blocking air circulation. Check if condenser motor can rotate. Watch fingers – turn unit off first! 5) Check hot gas valve for leaking. Let the compressor run in manual for some time. Stop compressor and see if the suction pressure rises more than normal. If valve is defective, replace valve. 					
Criteria	Temperature no longer in-range. Has been in range for minimum 30 min. and after that in out-range for more than 4 consecutive hours.					
Controller action	None					
	Log	X	Alarm	X	Alarm light	Quick flash
Consequence	If error is detected during PTI-test, PTI-test will fail					
Elimination	Alarm will be marked as inactive in alarm list when in-range is reached and alarm may then be deleted.					
Log data	Parm 1	Parm 2	Parm 3	Parm 4	Parm 5	
	Active/Inactive	Tset	Tact			



604	High press trouble					Fatal Alarm
Description	High Pressure Switch is active					
Cause	Hot gas valve, expansion valve and economizer valves are all closed and compressor is running					
Trouble shooting	<p><u>Possible causes:</u></p> <ul style="list-style-type: none"> Repeated high pressure alarms. <p><u>Accompanied alarms:</u></p> <ul style="list-style-type: none"> AL 306. <p><u>Trouble shooting:</u></p> <p>1) See and clear error for alarm AL 306</p>					
Criteria	AL 306 has been active 3 times within 30 min.					
Controller action	Control not possible					
	Log	X	Alarm	X	Alarm light	Quick flash
Consequence	Unit stop					
Elimination	Alarm 604 will be marked as inactive in alarm list when alarm 306 disappears. After 30 min. restart delay unit starts again and alarm may then be deleted.					
Log data	Parm 1	Parm 2	Parm 3	Parm 4	Parm 5	
	Active/Inactive					

607	AirEx open					Fatal Alarm
Description	Air exchange valve open in conflict with settings					
Cause	Indication of user having left air exchange open					
Trouble shooting	<p><u>Possible causes:</u></p> <ul style="list-style-type: none"> Air exchange valve open in freeze mode or AV+ mode Air exchange open in 50% - 60% RH. Cable or air exchange sensor defective or not calibrated correctly <p><u>Accompanied alarms:</u></p> <ul style="list-style-type: none"> Possibly AL 305. <p><u>Trouble shooting:</u></p> <p>Calibrate the air exchange sensor (see Controller System Menu decal for air exchange sensor calibration)</p> <p>1) See and clear error for alarm AL 305.</p> <p>2) Close air exchange. If air exchange is closed, cable for air exchange sensor or sensor is defective see AL 305 for trouble shooting.</p>					
Criteria	Air exchange is open while unit being in the frozen mode, dehumidification with set point below 60%, and or with CA or AV+ running.					
Controller action	None					
	Log	X	Alarm	X	Alarm light	Quick flash
Consequence	Deteriorated control precision					
Elimination	Alarm will be marked as inactive in alarm list when air exchange is closed and may then be deleted.					
Log data	Parm 1	Parm 2	Parm 3	Parm 4	Parm 5	
	Active/Inactive					

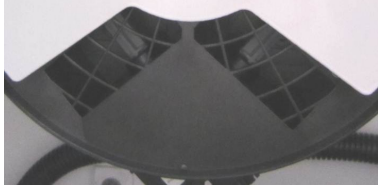

608	Select AirEx type					Warning
Description	AirEx type missing					
Cause	AirEx type not set					
Trouble shooting	<p><u>Possible causes:</u></p> <ul style="list-style-type: none"> AirEx type is set to NONE in Settings <p><u>Accompanied alarms:</u></p> <ul style="list-style-type: none"> None <p><u>Trouble shooting:</u></p> <p>Go to Settings and Configuration, and choose either 35m3/h or 75m3/h depending on valve type.</p> <p>35 m3/h</p>  <p>75 m3/h</p> 					
Criteria	-					
Controller action	None					
	Log	X	Alarm	X	Alarm light	None
Consequence	-					
Elimination	Alarm will be marked as inactive in alarm list when air exchange is set and may then be deleted.					
Log data	Parm 1	Parm 2	Parm 3	Parm 4	Parm 5	
	Active/Inactive	0	0	0	0	



609	Defrost Trouble					Warning
Description	Defrost is running					
Cause	Defrost terminated on Tsuc					
Trouble shooting	<p><u>Possible causes:</u></p> <ul style="list-style-type: none"> • Hot gas valve not working probably. • Defective Psuc. • Defective Tevap. <p><u>Accompanied alarms:</u></p> <ul style="list-style-type: none"> • Maybe AL 207 • Maybe AL 123 • Maybe AL 610 <p><u>Trouble shooting:</u></p> <ol style="list-style-type: none"> 1) If companied alarms AL 207 or AL 123 run troubleshooting for these alarms first. 2) Hot gas valve is not working probably. Let the compressor run by 35 Hz in manual. Open hot gas valve 50% and control the valve function. Is the sound as usual? If not control with a permanent magnet and test coil function. 3) If it looks like the hot gas valve is working as usual run function test step compressor. If alarms, look for troubleshooting for these alarms. 4) If no alarms, run a manual activated defrost and follow the behavior of Tevap, Tsuc, Tret, and Psuc 					
Criteria	Defrost terminated on Tsuc above 30°C (86°F)					
Controller action	None					
	Log	X	Alarm	X	Alarm light	Off
Consequence	If not solved, the defrost takes longer time than necessary					
Elimination	Warning will be marked as inactive in the alarm list when a defrost runs as expected. Alarm may then be deleted.					
Log data	Parm 1	Parm 2	Parm 3	Parm 4	Parm 5	
	Active/Inactive	Tsuc	Tevap	T0	Defrost time	



610	Defrost time exceed					Warning
Description	Max. defrost time exceeded					
Cause	Defrost terminated on time > 45 minutes					
Trouble shooting	<p><u>Possible causes:</u></p> <ul style="list-style-type: none"> • There has been too much ice in the evaporator. • The heaters are not working/defective. • Defective Psuc pressure transmitter. • Defective Pdis pressure transmitter. • Defective Tevap evaporator temperature sensor. • Lack of refrigerant <p><u>Accompanied alarms:</u></p> <ul style="list-style-type: none"> • Maybe alarm AL 203 is active. <p><u>Trouble shooting:</u></p> <ol style="list-style-type: none"> 1) Check and clear other alarms first. Check refrigerant level. 2) Check pressure transmitter configuration and confirm values from Psuc and Pdis by comparing them to gauge readings. 3) Start a manual defrost time to remove remaining ice now. See if there has been used current for the heaters on the information menu - Current phase 1, 2 and 3 should be above 6 A when the heater symbol, Σ, is shown on the display. If current is lower, check if there is power for the heaters. 4) Run a PTI test after the cargo is unloaded. 					
Criteria	Defrost time has exceeded 45 min.					
Controller action	None					
	Log	X	Alarm	X	Alarm light	Off
Consequence	All the ice may not have been melted with a deteriorated yield					
Elimination	Alarm will be marked as inactive when a new defrosting is terminated on temperature and may then be deleted.					
Log data	Parm 1	Parm 2	Parm 3	Parm 4	Parm 5	
	Active/Inactive	Max defrost time	Act. max defr. time			



611	Too many sensor errors				Alarm
Description	Too many (controlling) sensors have errors				
Cause	If too many (controlling) sensors have errors, the controller cannot maintain correct temperature. See also "Temperature control" p. 19 and "Expansion valve control" p. 19				
Trouble shooting	<p><u>Possible causes:</u></p> <ul style="list-style-type: none"> • One or more temperature sensors are defective. • One or more pressure transmitters are defective. <p><u>Accompanied alarms:</u></p> <ul style="list-style-type: none"> • Alarms AL 1XX or AL 2XX are active. <p><u>Trouble shooting:</u></p> <p>This alarm only appears when one or more controlling sensors have failure and there are no substitute sensors.</p> <p>1) See alarm list for the specific sensors</p>				
Criteria	Can not substitute faulty sensors with value from another sensor				
Controller action	None				
	Log	X	Alarm	X	Alarm light
Consequence	Deteriorated control precision in the frozen mode				
Elimination	When a sensors slot value enters valid range, it is marked as inactive in alarm list and may then be deleted. Values must be valid for 120 sec. to set alarm inactive.				
Log data	Parm 1	Parm 2	Parm 3	Parm 4	Parm 5
	Active/Inactive				

612	FC trouble				Alarm
Description	There have been several FC alarms within short time				
Cause	The FC reports unstable operation within 30 min. or a permanent FC error within the last 15 min.				
Trouble shooting	<p><u>Possible causes:</u></p> <ul style="list-style-type: none"> • Repeated FC errors. <p><u>Accompanied alarms:</u></p> <ul style="list-style-type: none"> • Alarms AL 5XX are/have been active. <p><u>Trouble shooting:</u></p> <p>1) Check and clear other FC alarms first – AL 5XX. Then this alarm should disappear. Turn unit off and turn it on again to make a quicker start up after alarms have been removed.</p> <p>If this alarm continues, the FC must be replaced and the unit can meanwhile run in emergency mode, "Emergency Operation" p. 51</p>				
Criteria	There have been several FC errors within the last 30 min. or a constant FC error				
Controller action					
	Log	X	Alarm	X	Alarm light
Consequence	Restart time for the FC is extended to 15 min.				
Elimination	When the FC has been without errors for more than 1 hours, this alarm is marked inactive and can be deleted.				
Log data	Parm 1	Parm 2	Parm 3	Parm 4	Parm 5
	Active/Inactive				



613	Motor trouble					Alarm
Description	Evaporator fan motor 1 or 2 or condenser fan motor overheated several times					
Cause	One or both evaporator fan motors or the condenser fan motor are overheating either permanently or repeatedly generated overheat alarm within the last 30 min.					
Trouble shooting	<p><u>Possible causes:</u></p> <ul style="list-style-type: none"> • Repeated evaporator fan motor trouble • Repeated condenser fan motor trouble <p><u>Accompanied alarms:</u></p> <ul style="list-style-type: none"> • Alarms AL 400, AL 401 or AL 402 are/have been active <p><u>Trouble shooting:</u></p> <ol style="list-style-type: none"> 1) Check and clear AL 400, AL 401 or AL 402 first 2) Check that the condenser fan can rotate freely 3) Check that the evaporator fans can rotate freely 4) Check contactors, interlock and aux. contactors 5) Change the defective motor 					
Criteria	There have been several overheating signals or a permanent overheating signal from evaporator fan motor 1 or 2 or condenser fan motor within 30 min.					
Controller action	Restart delay increased to 10-12 min.					
	Log	X	Alarm	X	Alarm light	Slow flash
Consequence	Evaporator fan motor: There is no or limited air circulation in the container. Condenser fan motor: There is limited capacity in the condenser.					
Elimination	When the evaporator fan motors and the condenser fan motor have been without errors for more than 1 hour, this alarm is marked inactive and can be deleted.					
Log data	Parm 1	Parm 2	Parm 3	Parm 4	Parm 5	
	Active/Inactive					

614	Humidity deactivated					Alarm
Description	Humidity control deactivated					
Cause	Indication of defective relative humidity sensor or its measuring circuitry					
Trouble shooting	<p><u>Possible causes:</u></p> <ul style="list-style-type: none"> • Defective humidity sensor. <p><u>Accompanied alarms:</u></p> <ul style="list-style-type: none"> • Alarms AL 302 are/have been active. <p><u>Trouble shooting:</u></p> <ol style="list-style-type: none"> 1) Check and clear AL 400 or AL 401 first. 					
Criteria	Value below alarm limit 5% or above 110%. Value invalid for 120 sec. for alarm activation.					
Controller action	None					
	Log	X	Alarm	X	Alarm light	Slow flash
Consequence	Dehumidification impossible					
Elimination	When sensor value becomes valid, it is marked as inactive in alarm list and may then be deleted. Value must be valid for 120 sec. to set alarm inactive.					
Log data	Parm 1	Parm 2	Parm 3	Parm 4	Parm 5	
	Active/Inactive					



615	Mcond trouble					Alarm
Description	Condenser fan motor overheated several times					
Cause	Condenser fan motor is overheating either permanently or has repeatedly generated overheat alarm within the last 30 min.					
Trouble shooting	<p><u>Possible causes:</u></p> <ul style="list-style-type: none"> Repeated condenser fan motor trouble <p><u>Accompanied alarms:</u></p> <ul style="list-style-type: none"> Alarms AL 402 is/has been active <p><u>Trouble shooting:</u></p> <ol style="list-style-type: none"> 1) Check and clear AL 402 first 2) Check that the condenser fan can rotate freely 3) Check contactor K4 and K5, interlock and aux. contactor K5B 4) Change the defective motor 					
Criteria	There have been several overheating signals or a permanent overheating signal from condenser fan motor within 30 min.					
Controller action	Restart delay increased to 10-12 min.					
	Log	X	Alarm	X	Alarm light	Slow flash
Consequence	There is limited capacity in the condenser.					
Elimination	When the condenser fan motor have been without errors for more than 1 hour, this alarm is marked inactive and can be deleted.					
Log data	Parm 1	Parm 2	Parm 3	Parm 4	Parm 5	
	Active/Inactive					

616	Mevap trouble					Alarm
Description	Evaporator fan motor(s) overheated several times					
Cause	Evaporator fan motor(s) is overheating either permanently or has repeatedly generated overheat alarm within the last 30 min.					
Trouble shooting	<p><u>Possible causes:</u></p> <ul style="list-style-type: none"> Repeated evaporator fan motor(s) trouble <p><u>Accompanied alarms:</u></p> <ul style="list-style-type: none"> Alarms AL 400 and/or AL 401 is/has been active <p><u>Trouble shooting:</u></p> <ol style="list-style-type: none"> 1) Check and clear AL 400 and/or AL 401 first 2) Check the cabeling and that the evaporator fan can rotate freely 3) Check contactor K6 and K7, interlock and aux. contactor K7B 4) Change the defective motor 					
Criteria	There have been several overheating signals or a permanent overheating signal from evaporator fan motor within 30 min.					
Controller action	Restart delay increased to 10-12 min.					
	Log	X	Alarm	X	Alarm light	Slow flash
Consequence	There is limited air flow to cargo and possibly reduced capacity in the evaporator					
Elimination	When the evaporator fan motor(s) has been running without errors for more than 1 hour, this alarm is set as inactive and can be deleted.					
Log data	Parm 1	Parm 2	Parm 3	Parm 4	Parm 5	
	Active/Inactive					



620	Cpr start failed					Fatal Alarm
Description						
Cause						
Trouble shooting	Accompanied alarms: <ul style="list-style-type: none"> AL 621 Trouble shooting: 1) See AL 621					
Criteria						
Controller action	None					
	Log	X	Alarm	X	Alarm light	Quick flash
Consequence	No cooling of the cargo					
Elimination						
Log data	Parm 1	Parm 2	Parm 3	Parm 4	Parm 5	
	Active/Inactive					

621	Cpr restarted					Warning
Description	The compressor has been restarted					
Cause	No signal from FC that motor is running					
Trouble shooting	Possible causes: <ul style="list-style-type: none"> Too high discharge pressure at start up, unit will restart after a delay. Unit in emergency mode, but cables not rewired for emergency mode. Compressor defective. Accompanied alarms: <ul style="list-style-type: none"> There may be other alarms, ex. AL 306. Trouble shooting: 1) Check and clear AL 306 first (high pressure alarm). 2) The discharge pressure is too high at start up, unit will restart after a delay. 3) Check and clear AL 5XX (FC) alarms first. 4) Check wiring for the compressor motor, especially if unit is in emergency mode. 5) If this alarm remains active after several restarts, the compressor is defective and should be replaced.					
Criteria	The compressor did not start on the first attempt within 3 min.					
Controller action	None					
	Log	X	Alarm	X	Alarm light	Off
Consequence	There will be a longer start delay					
Elimination	When the compressor has started, the alarm is marked inactive and can be deleted					
Log data	Parm 1	Parm 2	Parm 3	Parm 4	Parm 5	
	Active/Inactive					



622	Loss of cooling				Warning
Description	The refrigeration systems tries to cool down but Tsup is above Tret				
Cause	No cooling capacity				
Trouble shooting	<p><u>Possible causes:</u></p> <ul style="list-style-type: none"> • System leak – loss of refrigerant • Defective compressor valve plate(s) • Defective compressor • Defective valves <p><u>Accompanied alarms:</u></p> <ul style="list-style-type: none"> • AL 623 <p><u>Trouble shooting:</u></p> <ol style="list-style-type: none"> 1) If more alarms are active, see troubleshooting for these alarms first 2) Check refrigerant level. If low, find leak point, repair and recharge unit 3) Check the function of these valves: Vexp, Veco and Vhg. Perform a function test and troubleshoot according to the test alarms 4) If the compressor has low performance, isolate the compressor. Recover the refrigerant from the compressor and check LP and HP valve plates for damage. Defective valve plates can be replaced if the bore of the cylinder is not damaged 5) Replace the defective compressor if replacement of valve plates is not possible or if another part of the compressor is defective 				
Criteria	Compressor is running AND evaporator heaters are off AND Tret is 0.5°C below Tsup AND inrange LED is off AND requested capacity is -100. All above criterieas must be true for 30 min. before alarm is activated.				
Controller action	None				
	Log	X	Alarm	X	Alarm light Off
Consequence	None				
Elimination				
Log data	Parm 1	Parm 2	Parm 3	Parm 4	Parm 5
	Tret	Tsup	FCType	FreqAct	Hevap pct.



623	Loss of cooling					Fatal Alarm
Description	The refrigeration systems tries to cool down but Tsup is above Tret					
Cause	No cooling capacity					
Trouble shooting	<p>Possible causes:</p> <ul style="list-style-type: none"> • System leak – loss of refrigerant • Defective compressor valve plate(s) • Defective compressor • Defective valves <p>Accompanied alarms:</p> <ul style="list-style-type: none"> • AL 622 <p>Trouble shooting:</p> <p>1) See AL 622</p>					
Criteria	Compressor running AND evaporator heaters are off AND Trest is 0.5°C below Tsup AND inrange LED is off AND requested capacity is -100. All above criterias must be true for 120 min. before the alarm is activated.					
Controller action	Unit stops until it is power cycled					
	Log	X	Alarm	X	Alarm light	Quick flash
Consequence	Unit stops until it is power cycled					
Elimination						
Log data	Parm 1	Parm 2	Parm 3	Parm 4	Parm 5	
	Tret	Tsup	FCType	FreqAct	Hevap pct.	



625	CT outrange				Alarm	
Description	Cold Treatment out of range					
Cause	Indication of insufficient yield or defective controller					
Trouble shooting	<p><u>Possible causes:</u></p> <ul style="list-style-type: none"> • Difference between treatment setpoint and maximum USDA temperature too small. • Container doors are open. • Other alarms active. • Not enough refrigerant for the compressor. • Defective or jammed evaporator motors. • Defective or jammed condenser motor. <p><u>Accompanied alarms:</u></p> <ul style="list-style-type: none"> • Other alarms may be active, especially USDA sensor alarms AL 109 to AL 120. <p><u>Trouble shooting:</u></p> <p>The unit will continue the cooling but the next steps could be checked anyway.</p> <ol style="list-style-type: none"> 1. Larger difference between treatment setpoint and maximum USDA temperature: <ul style="list-style-type: none"> - Treatment setpoint must be cooler. - Maximum USDA temperature must be warmer. Attention: Will require a longer duration!! 2. Close container doors. 3. Check and clear other alarms first. 4. Check if there is enough refrigerant in the unit. 5. Check if the condenser is filled with dirt and blocking air circulation. 6. Check if evaporator motors can rotate. Watch fingers – turn unit off first! 7. Check if condenser motor can rotate. Watch fingers – turn unit off first! 					
Criteria	USDA measured temperatures are no longer in-range					
Controller action	None					
	Log	X	Alarm	X	Alarm light	Quick flash
Consequence	Already passed treatment time will be reset					
Elimination	Alarm will be marked as inactive in alarm list when in-range is reached or CT is aborted and alarm may then be deleted.					
Log data	Parm 1	Parm 2	Parm 3	Parm 4	Parm 5	
	Active/Inactive	Tset	Tact	CT duration	CT remain days	



630	Manual phase dir					Warning
Description	Manually Selected Phase Direction					
Cause	Indication of insufficient yield or defective controller					
Trouble shooting	<p><u>Possible causes:</u></p> <ul style="list-style-type: none"> The user has selected a manual phase direction. <p><u>Accompanied alarms:</u></p> <ul style="list-style-type: none"> AL 423 should have been active before using manual phase direction has been used. <p><u>Trouble shooting:</u></p> <ol style="list-style-type: none"> The quality of the power frequency is so poor that the user must decide phase direction. Apply valid power supply to the unit. Ensure condenser fan is running the right direction if no better power supply is available. There is a failure in the power wiring for the unit. Check that there are 3 valid phases for the unit. There is a fault in the phase direction detection circuit. Turn unit off and on again and see if the phase can be detected now. If phases still can't be detected, replace the power module PCB. The main controller is defective. Replace main controller. 					
Criteria	User has manually selected phase direction					
Controller action	Use the selected phase direction					
	Log	X	Alarm	X	Alarm light	Slow flash
Consequence	User controls the rotation direction of the motors					
Elimination	When switched to automatic, the alarm is marked as inactive and can be deleted					
Log data	Parm 1	Parm 2	Parm 3	Parm 4	Parm 5	
	Active/Inactive		Manual phase dir. CW/CCW			



631	Fuse blown					Warning
Description	Blown Fuse for fan motors and heaters					
Cause	Indication of blown fuse					
Trouble shooting	<p><u>Possible causes:</u></p> <ul style="list-style-type: none"> • A 10 A fuse is blown. • Unit has used too much power. • There is a short-circuit in the power cables used in the unit. <p><u>Accompanied alarms:</u></p> <ul style="list-style-type: none"> • There may be other alarms. <p><u>Trouble shooting:</u></p> <ol style="list-style-type: none"> 1) Check the defective fuse in the control cabinet. Replace a defective fuse but only once! If it blows again, there is a short circuit! 2) Remove short circuits in the power supply or cables before applying power again. 					
Criteria	Supply voltages U1-2, U2-3, U1-3 are OK. Power consumption too high! The average current of the 2 highest currents is more than the double of the lowest current of I1, I2 or I3. Not checked during defrost. The evaporator motors must run.					
Controller action	FC will soon trip with error 516 and stop compressor					
	Log	X	Alarm	X	Alarm light	Off
Consequence	Deteriorated control precision and capacity					
Elimination	When currents are normal, it is marked as inactive in alarm list and may then be deleted. Value must be valid for 30 sec. to set alarm inactive.					
Log data	Parm 1	Parm 2	Parm 3	Parm 4	Parm 5	
	Active/Inactive	Index	I1	I2	I3	

632	Phase missing					Fatal alarm
Description	Phase missing					
Cause	Indication of lack of supply from one fase					
Trouble shooting	<p><u>Possible causes:</u></p> <ul style="list-style-type: none"> • Bad connection between controller and supply. • Bad connection or defective supply cable and or plug • Defect power meas module <p><u>Accompanied alarms:</u></p> <ul style="list-style-type: none"> • AL 423 <p><u>Trouble shooting:</u></p> <ol style="list-style-type: none"> 1) Check the connection from power meas module to power supply. 2) If supply is OK check power meas module. Replace power meas module if defective. If no replacement is available, disconnect communication cable manually. Set phase direction manually in configuration. 					
Criteria	Difference between highest and lowest measured phase voltage is more than 50 V AC					
Controller action						
	Log	X	Alarm	X	Alarm light	Off
Consequence	Deteriorated control precision and capacity					
Elimination	When currents are normal, it is marked as inactive in alarm list and may then be deleted. Value must be valid for 30 sec. to set alarm inactive.					



Log data	Parm 1	Parm 2	Parm 3	Parm 4	Parm 5
	Active/Inactive	Index	I1	I2	I3

Communication Alarms (AL 7XX)

700	FC missing					Fatal Alarm
Description	FC Missing					
Cause	Indication of defective FC, lack of or improper connection					
Trouble shooting	<p><u>Possible causes:</u></p> <ul style="list-style-type: none"> • Communication with FC broken. • Power voltage to the FC not applied (wired for emergency operation?). • Defective FC. • X8 cable is defective. • Main controller defective. <p><u>Accompanied alarms:</u></p> <ul style="list-style-type: none"> • AL 306 or one or more AL 5XX may also be active. <p><u>Trouble shooting:</u></p> <ol style="list-style-type: none"> 1) Verify that cable FC-com is mounted correctly according to wiring diagram inside the controller cabinet and not being damaged. 2) Check that power to the FC is not wired for emergency operation. 3) Verify that there are correct voltages on all 3 phases for the FC. 4) Measure with a multimeter that there is a small DC signal on the connector PCB for cable FC-com. <ol style="list-style-type: none"> a) If there is no signal: The main controller is defective. Replace the main controller. b) If there is signal: The FC is defective and must be replaced. If there is no FC replacement available, the unit can be rewired for emergency operation: See "Emergency Operation" p. 51 					
Criteria	Communication with FC not possible					
Controller action	Mcond, Mevap1 and Mevap2 fan motors forced to low speed					
	Log	X	Alarm	X	Alarm light	Quick flash
Consequence	Unit stop					
Elimination	When sensor value becomes valid, it is marked as inactive in alarm list and may then be deleted.					
Log data	Parm 1	Parm 2	Parm 3	Parm 4	Parm 5	
	Active/Inactive		Status		Quality	



710	Display missing (Seen in Star View)					Warning
Description	No communication with display					
Cause	Indication of defective display, lack of or improper connection					
Trouble shooting	<p><u>Possible causes:</u></p> <ul style="list-style-type: none"> • Communication with display broken. • Defective display. • X11 cable is defective. • Main controller defective. <p><u>Accompanied alarms:</u></p> <ul style="list-style-type: none"> • AL 720, AL 721 and AL 9XX may also be active. <p><u>Trouble shooting:</u></p> <ol style="list-style-type: none"> 1) Verify that cable COM is mounted correctly (and is not damaged) according to wiring diagram inside the controller cabinet. 2) Verify that there are correct voltages 12 V DC on wire 1. 3) Measure with a multimeter that there is a small DC signal on the wires 2 and 3 connector PCB for cable COM. <ol style="list-style-type: none"> a) If there is no signal: The main controller is defective. Replace the main controller. b) If there is signal: The display is defective and must be replaced. If there is no display permanent replacement available, a substitution display can be used for setting values and evaluate the unit's status. 					
Criteria	Communication via the display is not possible					
Controller action	None, unit can perform normally without display					
	Log	X	Alarm	X	Alarm light	(not working)
Consequence	Unit stop					
Elimination	When sensor value becomes valid, it is marked as inactive in alarm list and may then be deleted.					
Log data	Parm 1	Parm 2	Parm 3	Parm 4	Parm 5	
	Active/Inactive	0	0	0	Error code	



711	Display com (Seen in Star View)					Warning
Description	Reduced communication with display (Not yet implemented)					
Cause	Indication of defective display, lack of or improper connection					
Trouble shooting	<p><u>Possible causes:</u></p> <ul style="list-style-type: none"> • Communication with display broken. • Defective display. • X11 cable is defective. • Main controller defective. <p><u>Accompanied alarms:</u></p> <ul style="list-style-type: none"> • AL 710, AL 730 and AL 9XX may also be active. <p><u>Trouble shooting:</u></p> <ol style="list-style-type: none"> 1) Verify that cable COM is mounted correctly (and is not damaged) according to wiring diagram inside the controller cabinet. 2) Verify that there are correct voltages 12 V DC on wire 1. 3) Measure with a multimeter that there is a small DC signal on the wires 2 and 3 connector PCB for cable COM. <ol style="list-style-type: none"> a) If there is no signal: The main controller is defective. Replace the main controller. b) If there is signal: The display is defective and must be replaced. If there is no display permanent replacement available, a substitution display can be used for setting values and evaluate the unit's status. 					
Criteria	Communication via the display is not possible					
Controller action	None, unit can perform normally without display					
	Log	X	Alarm	X	Alarm light	(not working)
Consequence	Unit stop					
Elimination	When sensor value becomes valid, it is marked as inactive in alarm list and may then be deleted.					
Log data	Parm 1	Parm 2	Parm 3	Parm 4	Parm 5	
	Active/Inactive	0	0	0	0	



720	Power module missing					Alarm
Description	No communication					
Cause	Indication of defective power module, lack of or improper connection					
Trouble shooting	<p><u>Possible causes:</u></p> <ul style="list-style-type: none"> • Communication with power module SPM6 broken. • 12 V DC to the power module SPM6 not applied. • Defective power module SPM6. • X11 cable is defective. • Main controller defective. <p><u>Accompanied alarms:</u></p> <ul style="list-style-type: none"> • AL 710, AL 711, AL 720 and one or more AL 9XX may also be active. <p><u>Trouble shooting:</u></p> <ol style="list-style-type: none"> 1) Verify that power module cable is mounted correctly (and is not damaged) according to wiring diagram inside the controller cabinet. 2) Verify that plugs are properly connected. 3) Verify that there are correct voltages on all 3 phases for the power module. 4) Measure with a multimeter that there is a small DC signal on the connector PCB for power module-com. <ol style="list-style-type: none"> a) If there is no signal: The main controller is defective. Replace the main controller. b) If there is signal: The power module is defective and must be replaced. 					
Criteria	Communication with controller not possible					
Controller action	Mcond, Mevap1 and Mevap2 fan motors forced to low speed					
	Log	X	Alarm	X	Alarm light	Quick flash
Consequence	Unit stop					
Elimination	When sensor value becomes valid, it is marked as inactive in alarm list and may then be deleted.					
Log data	Parm 1	Parm 2	Parm 3	Parm 4	Parm 5	
	Active/Inactive	0	0	0	Error code	

721	Power module com					Warning
Description	Reduced communication power module (Not yet implemented)					
Cause	Indication of defective power module, lack of or improper connection					
Trouble shooting	See AL 720					
Criteria	Communication with controller not possible					
Controller action	Mcond, Mevap1 and Mevap2 fan motors forced to low speed					
	Log	X	Alarm	X	Alarm light	Quick flash
Consequence	Unit stop					
Elimination	When sensor value becomes valid, it is marked as inactive in alarm list and may then be deleted.					
Log data	Parm 1	Parm 2	Parm 3	Parm 4	Parm 5	
	Active/Inactive	Quality	0	0	0	



730	RH sensor missing				Alarm	
Description	RH sensor communication missing					
Cause	Indication of defective RH sensor, or lack of or improper connection					
Trouble shooting	<p><u>Possible causes:</u></p> <ul style="list-style-type: none"> • Communication with RH sensor broken. • Defective RH sensor. • X10 cable is defective. • Main controller defective. • CO2 sensor defective (for some models). • O2 sensor defective (for some models). <p><u>Accompanied alarms:</u></p> <ul style="list-style-type: none"> • AL 302 or one or more AL 9XX may also be active. <p><u>Trouble shooting:</u></p> <ol style="list-style-type: none"> 1) Verify that cable RH-com is mounted correctly (and is not damaged) according to wiring diagram inside the controller cabinet. 2) Verify that plugs are properly connected. 3) Verify that there are correct voltages 12 V DC between 1 and 4 on X10 or between 1 and 2 on X73. 4) If model has CO2 and or O2 sensor, see troubleshooting for AL 740 and or AL 760 in "Operating and service manual Controlled Atmosphere" 5) Measure with a multimeter that there is a small DC signal between 2 and 3 on X10, and between 2 and 3 on X75. <ol style="list-style-type: none"> a) If there is no signal: The main controller is defective and must be replaced. b) If there is signal: The RH sensor is defective and must be replaced. 					
Criteria	Communication with RH sensor not possible					
Controller action	Dehumidification is overruled					
	Log	X	Alarm	X	Alarm light	Slow flash
Consequence	Dehumidification is impossible and dehumidification will stop					
Elimination	When sensor value becomes valid, it is marked as inactive in alarm list and may then be deleted.					
Log data	Parm 1	Parm 2	Parm 3	Parm 4	Parm 5	
	Active/Inactive	0	0	0	Error code	



731	RH sensor com					Warning
Description	RH sensor communication reduced (Not yet implemented)					
Cause	Indication of defective RH sensor, or lack of or improper connection					
Trouble shooting	<p><u>Possible causes:</u></p> <ul style="list-style-type: none"> • Communication with RH sensor broken. • Defective RH sensor. • X10 cable is defective. • Main controller defective. • CO2 sensor defective (for some models). • O2 sensor defective (for some models). <p><u>Accompanied alarms:</u></p> <ul style="list-style-type: none"> • - <p><u>Trouble shooting:</u></p> <p>1) Further description to follow upon implementation</p>					
Criteria	Communication with RH sensor not possible					
Controller action	Dehumidification is overruled					
	Log	X	Alarm	X	Alarm light	Slow flash
Consequence	Dehumidification is impossible and dehumidification will stop					
Elimination	When sensor value becomes valid, it is marked as inactive in alarm list and may then be deleted.					
Log data	Parm 1	Parm 2	Parm 3	Parm 4	Parm 5	
		0	0	0	0	

Test Alarms (AL 8XX)

800	Func test failed					Alarm
Description	Function Test Fault					
Cause						
Trouble shooting	<p><u>Possible causes:</u></p> <ul style="list-style-type: none"> • One or more of the individual test steps have failed. <p><u>Accompanied alarms:</u></p> <ul style="list-style-type: none"> • AL 8XX. <p><u>Trouble shooting:</u></p> <p>1) See individual AL 8XX alarms for cause</p>					
Criteria	One or more of the individual test steps have failed					
Controller action	FC will soon trip with error 516 and stop compressor					
	Log	X	Alarm	X	Alarm light	Slow flash
Consequence	Deteriorated control precision and capacity					
Elimination	When currents are normal, it is marked as inactive in alarm list and may then be deleted. Value must be valid for 30 sec. to set alarm inactive.					
Log data	Parm 1	Parm 2	Parm 3	Parm 4	Parm 5	
	Active/Inactive					



801	Controller				Alarm	
Description	Controller Internal Voltage Reference Fault					
Cause						
Trouble shooting	<p><u>Possible causes:</u></p> <ul style="list-style-type: none"> • Power supply for main controller is not sufficient. • Main controller defective. <p><u>Accompanied alarms:</u></p> <ul style="list-style-type: none"> • Check for AL 951 up to AL 996 • There may be other accompanied alarms. <p><u>Trouble shooting:</u></p> <ol style="list-style-type: none"> 1) See trouble shooting for accompanied alarms. If none appears, then proceed with 3). 2) Clear other active sensor alarms. 3) The power supply or power-cable for main controller defective. Measure voltage for the main controller. <ol style="list-style-type: none"> a. If voltage is OK, the main controller is defective and main controller must be replaced. b. Measure voltage for all sensors. Should be between 4.80 V DC and 5.20 V DC for temperature and pressure transmitters. Humidity sensor must be between 12.00 V DC and 34.00 V DC. If not OK, the sensor or cable is defective. Replace sensor. c. Measure outlet on transformer between T3 and T4. Correct range 15.30 V AC – 24.30 V AC. Measure between T5 and T6. Correct range 18.86 V AC – 30.00 V AC. If within range transformer is OK. d. Replace main controller. 					
Criteria	One or more of the internal reference voltages are out of limits					
Controller action	FC will soon trip with AL 516 and stop compressor					
	Log	X	Alarm	X	Alarm light	Slow flash
Consequence	Test failed					
Elimination	Alarm may then be deleted after test completed					
Log data	Parm 1	Parm 2	Parm 3	Parm 4	Parm 5	
	Active/Inactive	Step no.				



805	Idle current					Alarm
Description	Unit idle overcurrent fault					
Cause						
Trouble shooting	<p><u>Possible causes:</u></p> <ul style="list-style-type: none"> • There is a short-circuit in the main controller. • The power module PCB is defective. <p><u>Accompanied alarms:</u></p> <ul style="list-style-type: none"> • N/A. <p><u>Trouble shooting:</u></p> <ol style="list-style-type: none"> 1) Check cables for sensors for damages. 2) The main controller is defective. Replace the main controller. 					
Criteria	Idle current exceeds limit of 0.3 A with only controller running					
Controller action	None					
	Log	X	Alarm	X	Alarm light	Slow flash
Consequence	Test failed					
Elimination	Alarm may then be deleted after test completed					
Log data	Parm 1	Parm 2	Parm 3	Parm 4	Parm 5	
	Active/Inactive	INom	I1	I2	I3	

810	Mevap cur LO speed					Alarm
Description	Evaporator motor low speed current fault					
Cause	Indication of defective motor or defective supply cables to motor					
Trouble shooting	<p><u>Possible causes:</u></p> <ul style="list-style-type: none"> • Evaporator motor jammed or defective. • Evaporator motor cables defective. • Bad connection in plug • Evaporator motor cables wired wrong in controller cabinet. <p><u>Accompanied alarms:</u></p> <ul style="list-style-type: none"> • N/A. <p><u>Trouble shooting:</u></p> <ol style="list-style-type: none"> 1) Check the evaporator motor fans can rotate freely. Turn off power first! Replace motor or make it turn freely again. 2) Check evaporator motor cables for damages. 3) Check that the evaporator motor cables are mounted correctly 					
Criteria	Evaporator fan motors have exceeded current limit at low speed. 0.6 – 0.7 Amp on one or more phases					
Controller action	None					
	Log	X	Alarm	X	Alarm light	Slow flash
Consequence	Test failed					
Elimination	Alarm may then be deleted after test completed					
Log data	Parm 1	Parm 2	Parm 3	Parm 4	Parm 5	
	Active/Inactive	INom	I1	I2	I3	



811	Mevap cur HI speed					Alarm
Description	Evaporator motor high speed current fault					
Cause	Indication of defective motor or defective supply cables to motor					
Trouble shooting	<p><u>Possible causes:</u></p> <ul style="list-style-type: none"> • Evaporator motor jammed or defective. • Evaporator motor cables defective. • Bad connection in plug • Evaporator motor cables wired wrong in controller cabinet. <p><u>Accompanied alarms:</u></p> <ul style="list-style-type: none"> • N/A. <p><u>Trouble shooting:</u></p> <ol style="list-style-type: none"> 1) Check the evaporator motor fans can rotate freely. Turn off power first! Replace motor(s) or make it turn freely again. 2) Check evaporator motor cables for damages. 3) Check that the evaporator motor cables are mounted correct 					
Criteria	Evaporator fan motors have exceeded current limit at high speed. 50 Hz: 1.8 – 1.9 Amp 60 Hz: 2.1 – 2.6 Amp					
Controller action	None					
	Log	X	Alarm	X	Alarm light	Slow flash
Consequence	Test failed					
Elimination	Alarm may then be deleted after test completed					
Log data	Parm 1	Parm 2	Parm 3	Parm 4	Parm 5	
	Active/Inactive	INom	I1	I2	I3	

812	Mevap current OFF					Alarm
Description	Evaporator Motor Off Current Fault					
Cause	Indication of defective motor contactor or contactor driver circuitry					
Trouble shooting	<p><u>Possible causes:</u></p> <ul style="list-style-type: none"> • Defective evaporator motor contactor. • Defective contactor driver circuit. <p><u>Accompanied alarms:</u></p> <ul style="list-style-type: none"> • N/A <p><u>Trouble shooting:</u></p> <ol style="list-style-type: none"> 1) Check the evaporator motor contactor for defects. Replace the contactor. 2) Check that the evaporator motor cables are mounted correctly 					
Criteria	Evaporator fan motors have exceeded off current limit					
Controller action	None					
	Log	X	Alarm	X	Alarm light	Slow flash
Consequence	Test failed					
Elimination	Alarm may then be deleted after test completed					
Log data	Parm 1	Parm 2	Parm 3	Parm 4	Parm 5	
	Active/Inactive	INom	I1	I2	I3	



813	Mevap direction	Alarm
Description	Not implemented yet	

815	Mcond cur LO speed	Alarm
Description	Condenser Motor Low Speed Current Fault	
Cause	Indication of defective motor or defective supply cables to motor	
Trouble shooting	<p><u>Possible causes:</u></p> <ul style="list-style-type: none"> • Condenser motor jammed or defective. • Condenser motor cable defective. • Bad connection in plug • Condenser motor cable wired wrongly in controller cabinet or motor. <p><u>Accompanied alarms:</u></p> <ul style="list-style-type: none"> • N/A. <p><u>Trouble shooting:</u></p> <ol style="list-style-type: none"> 1) Check the condenser motor fan can rotate freely. Turn off power first! Replace motor or make it turn freely again. 2) Check motor cable for damages. 3) Check that the condenser motor cable is mounted correctly. 	
Criteria	Condenser fan motor has exceeded current limit at low speed. 0.2 – 0.3 Amp	
Controller action	None	
	Log	X Alarm X Alarm light Slow flash
Consequence	Test failed	
Elimination	Alarm may then be deleted after test completed	
Log data	Parm 1	Parm 2 Parm 3 Parm 4 Parm 5
	Active/Inactive	INom I1 I2 I3

816	Mcond cur HI speed	Alarm
Description	Condenser Motor High Speed Current Fault	
Cause	Indication of defective motor or defective supply cable to motor	
Trouble shooting	<p><u>Possible causes:</u></p> <ul style="list-style-type: none"> • Condenser motor jammed or defective. • Condenser motor cable defective. • Condenser motor cable wired wrongly in controller cabinet. <p><u>Accompanied alarms:</u></p> <ul style="list-style-type: none"> • N/A. <p><u>Trouble shooting:</u></p> <ol style="list-style-type: none"> 1) Check the Condenser motor fan can rotate freely. Turn off power first! Replace motor or make it turn freely again. 2) Check motor cable for damages. 3) Check that the condenser motor cables are mounted correctly 	
Criteria	Condenser fan motor has exceeded current limit at high speed. 50 Hz: 0.7 – 0.8 Amp 60 Hz: 1.0 – 1.8 Amp	
Controller action	None	
	Log	X Alarm X Alarm light Slow flash



Consequence	Test failed				
Elimination	Alarm may then be deleted after test completed				
Log data	Parm 1	Parm 2	Parm 3	Parm 4	Parm 5
	Active/Inactive	INom	I1	I2	I3

817	Mcond current OFF					Alarm
Description	Condenser Motor Off Current Fault					
Cause	Indication of defective motor contactor or defective contactor driver circuitry					
Trouble shooting	<p><u>Possible causes:</u></p> <ul style="list-style-type: none"> Defective condenser motor contactor. Defective contactor driver circuit. <p><u>Accompanied alarms:</u></p> <ul style="list-style-type: none"> N/A. <p><u>Trouble shooting:</u></p> <ol style="list-style-type: none"> Check the condenser motor contactor for defects. Replace the contactor. Check that the condenser motor cable is mounted correctly 					
Criteria	Condenser fan motor has exceeded off current limit					
Controller action	None					
	Log	X	Alarm	X	Alarm light	Slow flash
Consequence	Test failed					
Elimination	Alarm may then be deleted after test completed					
Log data	Parm 1	Parm 2	Parm 3	Parm 4	Parm 5	
	Active/Inactive	INom	I1	I2	I3	

820	Hevap current ON					Alarm
Description	Evaporator Heater On Current Fault					
Cause	Indication of defective heater(s) or defective supply cables to heater					
Trouble shooting	<p><u>Possible causes:</u></p> <ul style="list-style-type: none"> Heaters defective. Heater power cable defective. <p><u>Accompanied alarms:</u></p> <ul style="list-style-type: none"> N/A. <p><u>Trouble shooting:</u></p> <ol style="list-style-type: none"> Check the power cable for the heaters for defects. Replace cables if they are defective. The heater(s) are defective. Dismount the power for the heaters one by one to find the defective heater, see wiring schematics inside in the controller cabinet. Replace the defective heater. 					
Criteria	Evaporator heater has exceeded on current limit					
Controller action	None					
	Log	X	Alarm	X	Alarm light	Slow flash
Consequence	Test failed					
Elimination	Alarm may then be deleted after test completed					



Log data	Parm 1	Parm 2	Parm 3	Parm 4	Parm 5
	Active/Inactive	INom	I1	I2	I3

821	Hevap current OFF					Alarm
Description	Evaporator Heater Off Current Fault					
Cause	Indication of defective heater contactor or defective contactor driver circuitry					
Trouble shooting	<p><u>Possible causes:</u></p> <ul style="list-style-type: none"> Defective heater contactor. Defective contactor driver circuit. <p><u>Accompanied alarms:</u></p> <ul style="list-style-type: none"> N/A. <p><u>Trouble shooting:</u></p> <ol style="list-style-type: none"> Check the heater contactor for defects. Replace the contactor. Check that the heater power cable are mounted correctly 					
Criteria	Evaporator heater has exceeded off current limit					
Controller action	None					
	Log	X	Alarm	X	Alarm light	Slow flash
Consequence	Test failed					
Elimination	Alarm may then be deleted after test completed					
Log data	Parm 1	Parm 2	Parm 3	Parm 4	Parm 5	
	Active/Inactive	INom	I1	I2	I3	

840	Valve leaks					Alarm
Description	Valve Leak Fault					
Cause	Indication of leakage of one or more of the valves or problems with the compressor					
Trouble shooting	<p><u>Possible causes:</u></p> <ul style="list-style-type: none"> One or more valves have leaks (defective) <p><u>Accompanied alarms:</u></p> <ul style="list-style-type: none"> See other AL 84X alarms for valve failures. <p><u>Trouble shooting:</u></p> <ol style="list-style-type: none"> Check and clear other valve alarms, AL 84X 					
Criteria	Temperature indicates cooling					
Controller action	None					
	Log	X	Alarm	X	Alarm light	Slow flash
Consequence	Test failed					
Elimination	Alarm may then be deleted after test completed					
Log data	Parm 1	Parm 2	Parm 3	Parm 4	Parm 5	
	81.0X	T0	T0 old	Pdis	Pdis old	

See "Function test" p. 16



842	Expansion valve				Alarm	
Description	Expansion Valve Fault					
Cause	Indication of non-operating electronic expansion valve					
Trouble shooting	<p><u>Possible causes:</u></p> <ul style="list-style-type: none"> • Cable for expansion valve mounted on wrong valve. • Cable for expansion valve defective. • Expansion valve defective. • Driver circuit for expansion valve defective. <p><u>Accompanied alarms:</u></p> <ul style="list-style-type: none"> • N/A. <p><u>Trouble shooting:</u></p> <ol style="list-style-type: none"> 1) If there is more than one valve failure, the cables for the valves are presumably switched. Mount cables for valves on the correct valve. 2) Listen if the expansion valve is opening and closing. If not, then go to 4) If the valve is opening and closing, close service valve (pos. 14 P-I diag.) Run FT again. If the test now is a pass, the expansion valve is defective and should be replaced. 3) Check that the cable for the expansion valve is not defective. Replace cable if it is damaged. 4) Disconnect the cable for valve and measure that there is voltage on the output for the expansion valve when it should open. <ol style="list-style-type: none"> a. If there is no voltage, the main controller is defective. Replace the main controller. 					
Criteria	Pdis more than (>) 5 BarE: Max change on Pdis: ±0.75 Bar Pdis is less than (<) 5 BarE: Max change on Pdis: ±0.30 Bar Tret more than or equal (≥) to -15°C: Min change on T0: +20°K Tret is less than (<) -15°C: Min change on T0: +10°K					
Controller action	None					
	Log	X	Alarm	X	Alarm light	Slow flash
Consequence	Test failed					
Elimination	Alarm may then be deleted after test completed					
Log data	Parm 1	Parm 2	Parm 3	Parm 4	Parm 5	
	83.XX	T0	T0 diff.	Pdis	Pdis diff	

See "Function test" p. 16



843	Economizer valve					Alarm
Description	Economizer Valve Fault					
Cause	Indication of non-operating economizer valve					
Trouble shooting	<p><u>Possible causes:</u></p> <ul style="list-style-type: none"> • Cable for economizer valve mounted on wrong valve. • Cable for economizer valve defective. • Economizer valve defective. • Driver circuit for economizer valve defective. <p><u>Accompanied alarms:</u></p> <ul style="list-style-type: none"> • N/A. <p><u>Trouble shooting:</u></p> <ol style="list-style-type: none"> 1) If there is more than one valve failure, the cables for the valves are presumably switched. Mount cables for valves on the correct valve. 2) Listen if the economizer valve is opening and closing. If not, then go to 4). If the valve is opening and closing, close service valve (pos. 30 P-I diagr. intermediate line). Run the FT again, if the test now is a pass the economizer valve is defective and should be replaced. 3) Check that the cable for the expansion valve is not defective. Replace cable if it is damaged. 4) Disconnect the cable for valve and measure that there is voltage on the output for the expansion valve when it should open. <ol style="list-style-type: none"> a. If there is no voltage, the main controller is defective. Replace the main controller. 					
Criteria	Tsuc not changed at least 10°C (50°F) when opening economizer valve a certain time					
Controller action	None					
	Log	X	Alarm	X	Alarm light	Slow flash
Consequence	Test failed					
Elimination	Alarm may then be deleted after test completed					
Log data	Parm 1	Parm 2	Parm 3	Parm 4	Parm 5	
	82.XX	T0	Tc	FC power	PFC diff	

See "Function test" p. 16



844	Hot gas valve				Alarm	
Description	Hot gas Valve Fault					
Cause	Indication of non-operating hot gas valve					
Trouble shooting	<p><u>Possible causes:</u></p> <ul style="list-style-type: none"> • Cable for hot gas valve mounted on wrong valve. • Cable for hot gas valve defective. • Hot gas valve defective. • Driver circuit for hot gas valve defective. <p><u>Accompanied alarms:</u></p> <ul style="list-style-type: none"> • N/A. <p><u>Trouble shooting:</u></p> <ol style="list-style-type: none"> 1) If there is more than one valve failure, the cables for the valves are presumably switched. Mount cables for valves on the correct valve. 2) Listen if the hot gas valve is opening and closing, if not go to step 4). If the valve is opening and closing disconnect power to the solenoid coil, when the valve is closed and there is hot temperature after the valve (pos. 32 in the P – I diagram), the hot gas valve has a leak and should be replaced. Internal parts of the hot gas valve can be replaced separately. 3) Check that the cable for the hot gas valve is not defective. Replace cable if it is damaged. 4) Disconnect the cable for valve and measure that there is voltage on the output for the hot gas valve when it should open. <ol style="list-style-type: none"> a. If there is no voltage, the main controller is defective. Replace the main controller. 					
Criteria	Pdis more than (>) 5 BarE: Max change on Pdis: ±0.75 Bar Pdis is less than (<) 5 BarE: Max change on Pdis: ±0.30 Bar Tret is more than or equal (≥) to -15°C: Min. change on T0: +20°K Tret is less than (<) -15°C: Min. change on T0: +10°K					
Controller action	None					
	Log	X	Alarm	X	Alarm light	Slow flash
Consequence	Test failed					
Elimination	Alarm may then be deleted after test completed					
Log data	Parm 1	Parm 2	Parm 3	Parm 4	Parm 5	
	84.0X	T0	T0 diff.	Pdis	Pdis diff.	

See "Function test" p. 16



845	Cpr pump down					Alarm
Description	Compressor pump down fault					
Cause	Indication of insufficient performance in the compressor					
Trouble shooting	<p><u>Possible causes:</u></p> <ul style="list-style-type: none"> • Sensor defective (high pressure transmitter and or high pressure switch) • One or more valves defective. • Compressor needs repair. <p><u>Accompanied alarms:</u></p> <ul style="list-style-type: none"> • AL 250 <p><u>Trouble shooting:</u></p> <ol style="list-style-type: none"> 1) If alarm 250 is displayed check the high pressure transmitter settings and the high pressure switch. 2) If only alarm 845 is displayed, check that there is sufficient refrigerant on the unit. 3) If only alarm 845 is displayed, replace compressor valve plates. 					
Criteria	Tc - T0 more than (>) 20°C.					
Controller action	None					
	Log	X	Alarm	X	Alarm light	Slow flash
Consequence	Test failed					
Elimination	Alarm may then be deleted after test completed					
Log data	Parm 1	Parm 2	Parm 3	Parm 4	Parm 5	
	80.XX	T0	Psuc	Pdis	Tamb	

See "Function test" p. 16

846	FC Check					Alarm
Description	Internal fault in FC					
Cause	Indication of internal failure in the FC					
Trouble shooting	<p><u>Possible causes:</u></p> <ul style="list-style-type: none"> • Internal failure in the FC <p><u>Accompanied alarms:</u></p> <ul style="list-style-type: none"> • N/A. <p><u>Trouble shooting:</u></p> <ol style="list-style-type: none"> 1) Check and clear other alarms first. 2) Check that FC cover is mounted correctly with all screws. 3) Check motor cable (Connection cable between FC and compressor). 4) The FC needs repair and should be replaced 					
Criteria	FC temperature not increased by 15°C within 5 min. during step 8 of Function test					
Controller action	None					
	Log	X	Alarm	X	Alarm light	Slow flash
Consequence	Test failed					
Elimination	Alarm may then be deleted after test completed					
Log data	Parm 1	Parm 2	Parm 3	Parm 4	Parm 5	
	80.XX	Tfc	Tfc diff	Umotor	Ifc	



850	PTI test failed					Alarm
Description	PTI Test Fault					
Cause	Normal function will be affected					
Trouble shooting	<p><u>Possible causes:</u></p> <ul style="list-style-type: none"> • There is one or more alarms. <p><u>Accompanied alarms:</u></p> <ul style="list-style-type: none"> • AL 8XX and maybe other alarms. <p><u>Trouble shooting:</u></p> <p>1) There are other AL 8XX alarms. Check and clear the other alarms first. Then a new PTI test can be run.</p>					
Criteria	One or more of the individual PTI test steps have failed					
Controller action	None					
	Log	X	Alarm	X	Alarm light	Slow flash
Consequence	Test failed					
Elimination	Alarm may then be deleted after test completed					
Log data	Parm 1	Parm 2	Parm 3	Parm 4	Parm 5	
	Active/Inactive	ID	State	Test time [sec]	Alarm count	

855	PTI Tset 5					Alarm
Description	PTI 5°C Set Fault					
Cause	Indication of insufficient performance					
Trouble shooting	<p><u>Possible causes:</u></p> <ul style="list-style-type: none"> • Doors are open. • The heaters do not operate correctly. • There may not be enough refrigerant in the unit. • The cooling capacity is too limited. <p><u>Accompanied alarms:</u></p> <ul style="list-style-type: none"> • N/A. <p><u>Trouble shooting:</u></p> <p>1) Verify that the doors are closed.</p> <p>2) If start temperature was below +5°C, the heaters may be defective. Start the heaters in manual mode and see if the current consumption is higher than 5 A each phase.</p> <p>3) The unit may be lacking refrigerant. Check if the small red balls in the sight glass in the receiver (receiver tank) are not at the bottom when the unit is turned off. Search for leaks, repair and charge the unit.</p>					
Criteria	Set-point +5°C was not reached within the 3 hour limit					
Controller action	None					
	Log	X	Alarm	X	Alarm light	Slow flash
Consequence	Test failed					
Elimination	Alarm may then be deleted after test completed					
Log data	Parm 1	Parm 2	Parm 3	Parm 4	Parm 5	
	Active/Inactive	Tset	Tact	Tevap	Tret	



860	PTI Tset 0					Alarm
Description	PTI 0°C Set Fault					
Cause	Indication of insufficient performance					
Trouble shooting	<p><u>Possible causes:</u></p> <ul style="list-style-type: none"> • Doors are open. • The heaters do not operate normally. • There may not be enough refrigerant in the unit. • The cooling capacity is too limited. <p><u>Accompanied alarms:</u></p> <ul style="list-style-type: none"> • N/A. <p><u>Trouble shooting:</u></p> <ol style="list-style-type: none"> 1) Verify that the doors are closed. 2) If start temperature was below 0°C, the heaters may be defective. Start the heaters in manual mode and see if the current consumption is higher than 5 A each phase. 3) The unit may need refrigerant. Check if the small red balls in the sight glass in the receiver (receiver tank) are not at the bottom when the unit is turned off. Search for leaks, repair and charge the unit. 					
Criteria	Set-point 0°C was not reached within the 3 hour time limit					
Controller action	None					
	Log	X	Alarm	X	Alarm light	Slow flash
Consequence	Test failed					
Elimination	Alarm may then be deleted after test completed					
Log data	Parm 1	Parm 2	Parm 3	Parm 4	Parm 5	
	Active/Inactive	Tset	Tact	Tevap	Tret	



870	PTI defrost					Alarm
Description	PTI Defrost Fault					
Cause						
Trouble shooting	<p><u>Possible causes:</u></p> <ul style="list-style-type: none"> Defective Tevap temperature sensor. Defective Psuc pressure transmitter. Defective heaters. Defective hot gas valve. Evaporator was filled with too much ice. <p><u>Accompanied alarms:</u></p> <ul style="list-style-type: none"> N/A. <p><u>Trouble shooting:</u></p> <ol style="list-style-type: none"> Defrosting is terminated when Tevap rises above +15°C (+59°F). Check Tevap and Psuc sensors according to trouble shooting in alarms AL 123 and AL 207. The heaters may be defective. Start the heaters in manual mode and see if the current consumption is higher than 5 A per phase else the heaters or the power cables for the heaters may be defective. The hot gas valve is not working properly and the heaters may be defective. Check trouble shooting for the hot gas valve in alarm AL 844. See if the evaporator is filled with ice (through the inspection holes). Be careful with the evaporators fans! 					
Criteria	Defrost terminated on 45 min. time-out					
Controller action	None					
	Log	X	Alarm	X	Alarm light	Slow flash
Consequence	Test failed					
Elimination	Alarm may then be deleted after test completed					
Log data	Parm 1	Parm 2	Parm 3	Parm 4	Parm 5	
	Active/Inactive	Tset	Tact	Tevap	Tret	



880	PTI Tset -18					Alarm
Description	PTI -18°C Set Fault					
Cause	Indication of insufficient performance					
Trouble shooting	<p><u>Possible causes:</u></p> <ul style="list-style-type: none"> • Doors are open. • There may not be enough refrigerant in the unit. • The cooling capacity is too limited. • Hot gas valve leaking. <p><u>Accompanied alarms:</u></p> <ul style="list-style-type: none"> • N/A. <p><u>Trouble shooting:</u></p> <ol style="list-style-type: none"> 1) Verify that the doors are closed. 2) The unit may need refrigerant. Check if the small red balls in the sight glass in the receiver (receiver tank) are not at the bottom when the unit is turned off. Refill with refrigerant. 3) Hot gas valve is leaking. Feel both sides (before and after) the valve - there should be a temp. diff. in this case. 					
Criteria	Setpoint -18°C was not reached within the 3 hour time limit					
Controller action	None					
	Log	X	Alarm	X	Alarm light	Slow flash
Consequence	Test failed					
Elimination	Alarm may then be deleted after test completed					
Log data	Parm 1	Parm 2	Parm 3	Parm 4	Parm 5	
	Active/Inactive	Tset	Tact	Tevap	Tret	

Controller Alarms (AL 9XX)

900	User stop					Fatal Alarm
Description	User stop was executed from PC-program					
Cause						
Criteria	User stop was executed from PC-program					
Controller action						
	Log	X	Alarm	X	Alarm light	Quick flash
Consequence	Unit stops					
Elimination	User stop may be deleted from alarm list by means of keypad or PC-program. Unit will then restart.					
Log data	Parm 1	Parm 2	Parm 3	Parm 4	Parm 5	
	Active/Inactive					



902	Battery malfunction					Alarm
Description	Battery Malfunctioning					
Cause	Indication of defective battery					
Trouble shooting	<p><u>Possible causes:</u></p> <ul style="list-style-type: none"> The battery used for logging is defective. <p><u>Accompanied alarms:</u></p> <ul style="list-style-type: none"> AL 801 will be activated during FT- or PTI test. <p><u>Trouble shooting:</u></p> <p>The battery is defective. Dismount main controller, replace battery and remount main controller.</p>					
Criteria	Battery voltage is below limit for low battery alarm 8 V					
Controller action	None					
	Log	X	Alarm	X	Alarm light	Slow flash
Consequence	Logging in the battery mode not possible. When detected during test, test will fail					
Elimination	Alarm will be marked as inactive in alarm list when voltage reoccurs on battery. Alarm may then be deleted.					
Log data	Parm 1	Parm 2	Parm 3	Parm 4	Parm 5	
	Active/Inactive	Low limit		Present		

904	Datalog error					Alarm
Description	SCCU6 Data log Fault					
Cause	Circuit for storing the datalog is faulty					
Trouble shooting	<p><u>Possible causes:</u></p> <ul style="list-style-type: none"> Datalog in controller has become defective. <p><u>Accompanied alarms:</u></p> <ul style="list-style-type: none"> AL 801 will be activated during FT- or PTI test. <p><u>Trouble shooting:</u></p> <p>The unit will continue its temperature control, but the logging of data is unreliable.</p> <p>1) Replace main controller.</p>					
Criteria	Controller data log corrupted					
Controller action						
	Log	X	Alarm	X	Alarm light	Slow flash
Consequence	Data logging unreliable. Temperature control is functioning					
Elimination						
Log data	Parm 1	Parm 2	Parm 3	Parm 4	Parm 5	
	Active/Inactive	1 = R, W = 2				



905	Database corrupt					Log
Description	SCCU6 Database Faulty					
Cause	Failed validation of EEPROM backup					
Trouble shooting	<p><u>Possible causes:</u></p> <ul style="list-style-type: none"> Main controller defective. <p><u>Accompanied alarms:</u></p> <ul style="list-style-type: none"> AL 801 will be activated during FT- or PTI test. <p><u>Trouble shooting:</u></p> <p>1) Replace main controller.</p>					
Criteria	Controller database corrupted					
Controller action	Default value preset					
	Log	X	Alarm		Alarm light	Off
Consequence	Parameters may have changed					
Elimination						
Log data	Parm 1	Parm 2	Parm 3	Parm 4	Parm 5	
	Active/Inactive					

906	Invalid date and time					Alarm
Description	Invalid date and time					
Cause	Date and time not valid					
Trouble shooting	<p><u>Possible causes:</u></p> <ul style="list-style-type: none"> Date and time not entered correctly Real-time clock battery defective <p><u>Accompanied alarms:</u></p> <ul style="list-style-type: none"> AL 907 and AL 908 <p><u>Trouble shooting:</u></p> <p>1) Set date and time. Let the unit run for a couple of hours. Power off unit and wait a few minutes, then power on the unit again. Check date and time.</p> <p>2) If step 1 did not correct the problem, the real-time clock battery is defective. Replace main controller.</p>					
Criteria	Date and time not correct					
Controller action	None					
	Log	X	Alarm	X	Alarm light	Slow flash
Consequence	Invalid time/date in datalog					
Elimination	Set time/date. When alarm becomes inactive, it can be deleted					
Log data	Parm 1	Parm 2	Parm 3	Parm 4	Parm 5	
	Day	Month	Year	Hour	Minute	



907	Realtime error					Alarm
Description	Real-time Clock Unreliable					
Cause	Real-time clock battery defective					
Trouble shooting	<p><u>Possible causes:</u></p> <ul style="list-style-type: none"> Real-time clock battery defective. <p><u>Accompanied alarms:</u></p> <ul style="list-style-type: none"> AL 801 will be activated during FT- or PTI test. <p><u>Trouble shooting:</u></p> <ol style="list-style-type: none"> Turn on the unit and let it run for a couple of hours Real-time clock battery defective. Replace main controller. 					
Criteria	No acknowledge from real time clock					
Controller action						
	Log	X	Alarm	X	Alarm light	Slow flash
Consequence	Invalid date/time setting in datalog					
Elimination	Check real-time clock battery. Set time. Alarm may then be deleted					
Log data	Parm 1	Parm 2	Parm 3	Parm 4	Parm 5	
	Active/Inactive					

908	Realtime invalid					Log
Description	Real-time Clock Unavailable					
Cause	Real-time clock battery defective					
Trouble shooting	<p><u>Possible causes:</u></p> <ul style="list-style-type: none"> Real-time clock battery defective. <p><u>Accompanied alarms:</u></p> <ul style="list-style-type: none"> AL 801 will be activated during FT- or PTI test. <p><u>Trouble shooting:</u></p> <ol style="list-style-type: none"> Real-time clock battery defective. Replace main controller. 					
Criteria	Invalid reply from real time clock					
Controller action						
	Log	X	Alarm	X	Alarm light	Slow flash
Consequence	Invalid date/time setting in datalog					
Elimination	Check / replace real-time clock battery. Set time. Alarm may then be deleted					
Log data	Parm 1	Parm 2	Parm 3	Parm 4	Parm 5	
	Active/Inactive					



910	Main power failure					Log
Description	Main Power Fault					
Cause	Indication of insufficient supply voltage					
Trouble shooting	<p><u>Possible causes:</u></p> <ul style="list-style-type: none"> Unstable or insufficient power supply. <p><u>Accompanied alarms:</u></p> <ul style="list-style-type: none"> N/A. <p><u>Trouble shooting:</u></p> <p>1) Supply unit with power according to specification.</p>					
Criteria	Supply voltage below warning limit					
Controller action	Controller tries safe close-down. If power reappears, system restarts and triggers this alarm.					
	Log	X	Alarm	X	Alarm light	Off
Consequence	All contractors released, unit stops. Display and main controller remains active					
Elimination	Unit starts when correct power is available					
Log data	Parm 1	Parm 2	Parm 3	Parm 4	Parm 5	
	Active/Inactive					

911	Battery voltage LO					Warning
Description	Low Battery Voltage					
Cause	Indication of defective battery					
Trouble shooting	<p><u>Possible causes:</u></p> <ul style="list-style-type: none"> Battery defective or used. Battery cables defective. <p><u>Accompanied alarms:</u></p> <ul style="list-style-type: none"> AL 801 will be activated during FT- or PTI test. <p><u>Trouble shooting:</u></p> <p>1) Check that connectors/cables for the battery are not damaged. If so replace the battery.</p>					
Criteria	Battery voltage below warning limit for low battery voltage 11 V					
Controller action	None					
	Log	X	Alarm	X	Alarm light	Off
Consequence	If main power is removed, data logging may not be possible					
Elimination	Alarm will be marked as inactive in alarm list when battery voltage reoccurs. Alarm may then be deleted.					
Log data	Parm 1	Parm 2	Parm 3	Parm 4	Parm 5	
	Active/Inactive	Low limit	High limit	Actual		



912	Battery voltage HI					Log
Description	High Battery Voltage					
Cause						
Trouble shooting	<p><u>Possible causes:</u></p> <ul style="list-style-type: none"> • Battery defective. • Battery cables defective. <p><u>Accompanied alarms:</u></p> <ul style="list-style-type: none"> • AL 801 will be activated during FT- or PTI test. <p><u>Trouble shooting:</u></p> <p>1) Check that cables for the battery are not damaged and in contact with other voltages. If so replace the battery.</p>					
Criteria	Battery voltage above warning limit for high battery voltage 18 V					
Controller action	None					
	Log	X	Alarm		Alarm light	Off
Consequence	None					
Elimination						
Log data	Parm 1	Parm 2	Parm 3	Parm 4	Parm 5	
	Active/Inactive	Low limit	High limit	Actual		

Internal Voltage Reference Alarms

953	Temp ref 1 LO					Warning
Description	Controller Internal Voltage Reference Fault					
Cause	Indication of controller internal voltage reference fault					
Trouble shooting	<p><u>Possible causes:</u></p> <ul style="list-style-type: none"> • Defective power supply for main controller. • Defective sensor pulling power supply down. • Defective main controller. <p><u>Accompanied alarms:</u></p> <ul style="list-style-type: none"> • There may be sensor alarms. • AL 801 will be activated during FT- or PTI test. <p><u>Trouble shooting:</u></p> <p>1) Check if there are other active (sensor) alarms. Clear these alarms first using their trouble shooting.</p> <p>2) Check voltage level of 24 V DC and 5 V signals to see if power supply has a short circuit or other damages. If OK, the main controller is defective. Replace main controller.</p>					
Criteria	Reference voltage 1 below 3.16 V DC					
Controller action	None					
	Log	X	Alarm		Alarm light	Off
Consequence	Temperature measurement to high					
Elimination	Alarm will be marked as inactive in alarm list when supply voltage is correct. Alarm may then be deleted					
Log data	Parm 1	Parm 2	Parm 3	Parm 4	Parm 5	
	Active/Inactive	Low limit	High limit	Actual value	0	

The measured voltage is internal on the main controller and cannot easily be measured



954	Temp ref 1 HI					Warning
Description	Controller Internal Voltage Reference Fault					
Cause	Indication of controller internal voltage reference fault					
Trouble shooting	<p><u>Possible causes:</u></p> <ul style="list-style-type: none"> Defective power supply for main controller. Defective main controller. <p><u>Accompanied alarms:</u></p> <ul style="list-style-type: none"> There may be sensor alarms. AL 801 will be activated during FT- or PTI test. <p><u>Trouble shooting:</u></p> <ol style="list-style-type: none"> Check if there are other active (sensor) alarms. Clear these alarms first using their trouble shooting. Check voltage level of 24 V DC and 5 V signals to see if power supply has an open circuit or other damages. If voltages are OK, the main controller is defective. Replace main controller. 					
Criteria	Reference voltage 1 above 3.29 V DC					
Controller action	None					
	Log	X	Alarm		Alarm light	Off
Consequence	Temperature measurement to low					
Elimination	Alarm will be marked as inactive in alarm list when supply voltage is correct. Alarm may then be deleted					
Log data	Parm 1	Parm 2	Parm 3	Parm 4	Parm 5	
	Active/Inactive	Low limit	High limit	Actual value	0	

The measured voltage is internal on the main controller and cannot easily be measured

955	Temp ref 2 LO (See AL 953)					Warning
------------	-----------------------------------	--	--	--	--	----------------

The measured voltage is internal on the main controller and cannot easily be measured

956	Temp ref 2 HI (See AL 954)					Warning
------------	-----------------------------------	--	--	--	--	----------------



961	Pdis sens sup LO					Warning
Description	Controller Internal Voltage Reference Fault					
Cause	Indication of controller internal voltage reference fault					
Trouble shooting	<p><u>Possible causes:</u></p> <ul style="list-style-type: none"> Defective power supply for main controller. Defective Pdis pressure transmitter. Defective main controller. <p><u>Accompanied alarms:</u></p> <ul style="list-style-type: none"> There may be sensor alarms, especially AL 203. AL 801 will be activated during FT- or PTI test. <p><u>Trouble shooting:</u></p> <ol style="list-style-type: none"> Check if there are other active (sensor) alarms. Clear these alarms first using their trouble shooting. Access the "special menu" by pressing  for more than 3 sec. Scroll down until you see the label "U Pdis" in the display. The value of "U Pdis" should be in the range between 4.50 V and 5.5 V DC. While displaying "U Pdis", remove the connector at Pdis. <ul style="list-style-type: none"> If "U Pdis" is now inside the above range, the Pdis pressure transmitter is defective. Replace the Pdis pressure transmitter. If "U Pdis" is still outside the above range, proceed to next step. While displaying "U Pdis", disconnect Pdis from the terminals according to wiring schematics inside in the control cabinet. <ul style="list-style-type: none"> If "U Pdis" is now inside the above range, the cable for Pdis is defective. Replace cable for Pdis. If the correct voltage is measured at X22 then circuit is defective. Replace the main controller. 					
Criteria	Reference voltage Pdis below 5.50 V DC					
Controller action	None					
	Log	X	Alarm		Alarm light	Off
Consequence	Less accurate readings from measurement					
Elimination	Alarm will be marked as inactive in alarm list when supply voltage is correct. Alarm may then be deleted					
Log data	Parm 1	Parm 2	Parm 3	Parm 4	Parm 5	
	Active/Inactive	Low limit	High limit	Actual value	0	



962	Pdis sens sup HI					Warning
Description	Controller Internal Voltage Reference Fault					
Cause	Indication of controller internal voltage reference fault					
Trouble shooting	<p>Possible causes:</p> <ul style="list-style-type: none"> • Defective power supply for main controller. • Defective main controller. <p>Accompanied alarms:</p> <ul style="list-style-type: none"> • There may be sensor alarms, especially AL 203 • AL 801 will be activated during FT- or PTI test. <p>Trouble shooting:</p> <p>1) See "Trouble shooting" AL 961</p>					
Criteria	Reference voltage Pdis above 5.50 V DC					
Controller action	None					
	Log	X	Alarm		Alarm light	Off
Consequence	Less accurate readings from measurement					
Elimination	Alarm will be marked as inactive in alarm list when supply voltage is correct. Alarm may then be deleted					
Log data	Parm 1	Parm 2	Parm 3	Parm 4	Parm 5	
	Active/Inactive	Low limit	High limit	Actual value	0	



963	Psuc sens sup LO					Warning
Description	Controller Internal Voltage Reference Fault					
Cause	Indication of controller internal voltage reference fault					
Trouble shooting	<p><u>Possible causes:</u></p> <ul style="list-style-type: none"> Defective power supply for main controller. Defective Psuc pressure transmitter. Defective main controller. <p><u>Accompanied alarms:</u></p> <ul style="list-style-type: none"> There may be sensor alarms, especially AL 207. AL 801 will be activated during FT- or PTI test. <p><u>Trouble shooting:</u></p> <ol style="list-style-type: none"> Check if there are other active (sensor) alarms. Clear these alarms first using their trouble shooting. Access the "special menu" by pressing  for more than 3 sec. Scroll down until you see the label "U Psuc" in the display. The value of "U Psuc" should be in the range between 4.50 V and 5.5 V DC. While displaying "U Psuc", remove the connector at Psuc. <ul style="list-style-type: none"> If "U Psuc" is now inside the correct above range (4.50 V – 5.5 V DC), the Psuc pressure transmitter is defective. Replace the Psuc pressure transmitter. If "U Psuc" is still outside the above range, proceed to next step. While displaying "U Psuc", disconnect Pdis from the terminals according to wiring schematics inside in the control cabinet. <ul style="list-style-type: none"> If "U Psuc" is now inside the above range the cable for Psuc is defective. Mount connector correctly or replace connector cable for Psuc. If the correct voltage is measured at X22 then circuit is defective. Replace the main controller. 					
Criteria	Reference voltage Psuc below 4.50 V DC					
Controller action	None					
	Log	X	Alarm		Alarm light	Off
Consequence	Less accurate readings from measurement					
Elimination	Alarm will be marked as inactive in alarm list when supply voltage is correct. Alarm may then be deleted					
Log data	Parm 1	Parm 2	Parm 3	Parm 4	Parm 5	
	Active/Inactive	Low limit	High limit	Actual value	0	



964	Psuc sens sup HI					Warning
Description	Controller Internal Voltage Reference Fault					
Cause	Indication of controller internal voltage reference fault					
Trouble shooting	<p><u>Possible causes:</u></p> <ul style="list-style-type: none"> Defective power supply for main controller. Defective main controller. <p><u>Accompanied alarms:</u></p> <ul style="list-style-type: none"> There may be sensor alarms. AL 801 will be activated during FT- or PTI test. <p><u>Trouble shooting:</u></p> <p>1) See "Trouble shooting" for AL 963</p>					
Criteria	Reference voltage Psuc above 5.50 V DC					
Controller action	None					
	Log	X	Alarm		Alarm light	Off
Consequence	Less accurate readings from measurement					
Elimination	Alarm will be marked as inactive in alarm list when supply voltage is correct. Alarm may then be deleted					
Log data	Parm 1	Parm 2	Parm 3	Parm 4	Parm 5	
	Active/Inactive	Low limit	High limit	Actual value	0	

965	Controller sup LO					Warning
Description	Controller Internal Voltage Reference Fault					
Cause	Indication of controller internal voltage reference fault					
Trouble shooting	<p><u>Possible causes:</u></p> <ul style="list-style-type: none"> Defective power supply for main controller. Defective main controller. <p><u>Accompanied alarms:</u></p> <ul style="list-style-type: none"> There may be sensor alarms, especially AL 1XX and AL 2XX. AL 801 will be activated during FT- or PTI test. <p><u>Trouble shooting:</u></p> <p>1) Check if there are other active (sensor) alarms. Clear these alarms first using their trouble shooting.</p> <p>2) The main controller is defective. Replace the main controller.</p>					
Criteria	Reference voltage below 4.50 V DC					
Controller action	None					
	Log	X	Alarm		Alarm light	Off
Consequence	Less accurate readings from measurement from sensors X22 and X23					
Elimination	Alarm will be marked as inactive in alarm list when supply voltage is correct. Alarm may then be deleted					
Log data	Parm 1	Parm 2	Parm 3	Parm 4	Parm 5	
	Active/Inactive	Low limit	High limit	Actual value	0	



966	Controller sup HI					Warning
Description	Controller Internal Voltage Reference Fault					
Cause	Indication of controller internal voltage reference fault					
Trouble shooting	<p><u>Possible causes:</u></p> <ul style="list-style-type: none"> Defective power supply for main controller. Defective main controller. <p><u>Accompanied alarms:</u></p> <ul style="list-style-type: none"> There may be sensor alarms. AL 801 will be activated during FT- or PTI test. <p><u>Trouble shooting:</u></p> <ol style="list-style-type: none"> Check if there are other active (sensor) alarms. Clear these alarms first using their trouble shooting. Check voltage level of 24 V DC and 5 V signals to see if power supply has an open circuit or other damages. If voltages are OK, the main controller is defective. Replace main controller. 					
Criteria	Reference voltage above 5.50 V DC					
Controller action	None					
	Log	X	Alarm		Alarm light	Off
Consequence	Less accurate readings from measurement from sensors X22 and X23					
Elimination	Alarm will be marked as inactive in alarm list when supply voltage is correct. Alarm may then be deleted					
Log data	Parm 1	Parm 2	Parm 3	Parm 4	Parm 5	
	Active/Inactive	Low limit	High limit	Actual value	0	

The measured voltage is internal on the main controller and cannot easily be measured



967	AirExMot sup LO					Warning
Description	Controller Internal Voltage Reference Fault					
Cause	Indication of controller internal voltage reference fault					
Trouble shooting	<p><u>Possible causes:</u></p> <ul style="list-style-type: none"> Defective power supply for main controller. Defective sensor pulling power supply down. Defective main controller. <p><u>Accompanied alarms:</u></p> <ul style="list-style-type: none"> There may be sensor alarms, AL 3XX. AL 801 will be activated during FT- or PTI test. <p><u>Trouble shooting:</u></p> <ol style="list-style-type: none"> Check if there are other active (sensor) alarms. Clear these alarms first using their trouble shooting. Access the "special menu" by pressing  for more than 3 sec. Scroll down until you see the label "U Motor pos" in the display. The value of "U Motor pos" should be in the range between 4.50 and 5.5 V DC. While displaying "U Motor pos", remove the connector at AirEx potentiometer. <ul style="list-style-type: none"> If "U Motor pos" is now inside the correct above range (4.50 – 5.50 V DC), the motor potentiometer is defective. Replace the "AirMotor". If "U Motor pos" is still outside the above range, proceed to next step. While displaying "U Motor pos", disconnect "AirMotor" from the terminals according to wiring schematics inside in the control cabinet. <ul style="list-style-type: none"> If "U AirEx" is now inside the above range the cable for "AirMotor" is defective. Mount connector correctly or replace connector cable for "AirMotor". If the correct voltage is measured at X23 then circuit is defective. Replace the main controller. 					
Criteria	Reference voltage AirMotor below 4.50 V DC					
Controller action	None					
	Log	X	Alarm		Alarm light	Off
Consequence	Less accurate readings from measurement					
Elimination	Alarm will be marked as inactive in alarm list when supply voltage is correct. Alarm may then be deleted					
Log data	Parm 1	Parm 2	Parm 3	Parm 4	Parm 5	
	Active/Inactive	Low limit	High limit	Actual value	0	



968	AirExMot sup HI					Warning
Description	Controller Internal Voltage Reference Fault					
Cause	Indication of controller internal voltage reference fault					
Trouble shooting	<p><u>Possible causes:</u></p> <ul style="list-style-type: none"> Defective power supply for main controller. Defective main controller. <p><u>Accompanied alarms:</u></p> <ul style="list-style-type: none"> There may be sensor alarms, AL 3XX. AL 801 will be activated during FT- or PTI test. <p><u>Trouble shooting:</u></p> <ol style="list-style-type: none"> Check if there are other active (sensor) alarms. Clear these alarms first using their trouble shooting. Check voltage level of 24 V DC and 5 V signals to see if power supply has an open circuit or other damages. If the correct voltage is measured at X23 then circuit is defective. Replace main controller. 					
Criteria	Reference voltage motor pos above 5.50 V DC					
Controller action	None					
	Log	X	Alarm		Alarm light	Off
Consequence	Less accurate readings from measurement					
Elimination	Alarm will be marked as inactive in alarm list when supply voltage is correct. Alarm may then be deleted					
Log data	Parm 1	Parm 2	Parm 3	Parm 4	Parm 5	
	Active/Inactive	Low limit	High limit	Actual value	0	



969	AirEx sens sup LO					Warning
Description	Controller Internal Voltage Reference Fault					
Cause	Indication of controller internal voltage reference fault					
Trouble shooting	<p><u>Possible causes:</u></p> <ul style="list-style-type: none"> • Defective power supply for main controller. • Defective sensor pulling power supply down. • Defective main controller. <p><u>Accompanied alarms:</u></p> <ul style="list-style-type: none"> • There may be sensor alarms, AL 3XX. • AL 801 will be activated during FT- or PTI test. <p><u>Trouble shooting:</u></p> <ol style="list-style-type: none"> 1) Check if there are other active (sensor) alarms. Clear these alarms first using their trouble shooting. 2) Access the "special menu" by pressing  for more than 3 sec. Scroll down until you see the label "U AirEx" in the display. The value of "U AirEx" should be in the range between 4.50 V DC and 5.5 V DC. 3) While displaying "U AirEx", remove the connector at AirEx potentiometer. <ul style="list-style-type: none"> – If "U AirEx" is now inside the correct above range (4.50 – 5.50 V DC), the AirEx potentiometer is defective. Replace the AirEx potentiometer – If "U AirEx" is still outside the above range, proceed to next step. 4) While displaying "U AirEx", disconnect "AirEx" from the terminals according to wiring schematics inside in the control cabinet. <ul style="list-style-type: none"> – If "U AirEx" is now inside the above range the cable for "AirEx" is defective. Mount connector correctly or replace connector cable for "AirEx". – If the correct voltage is measured at X22 and at X23 then circuit is defective. Replace the main controller. 					
Criteria	Reference voltage AirEx below 4.50 V DC					
Controller action	None					
	Log	X	Alarm		Alarm light	Off
Consequence	Less accurate readings from measurement					
Elimination	Alarm will be marked as inactive in alarm list when supply voltage is correct. Alarm may then be deleted					
Log data	Parm 1	Parm 2	Parm 3	Parm 4	Parm 5	
	Active/Inactive	Low limit	High limit	Actual value	0	



970	AirEx sens sup HI					Warning
Description	Controller Internal Voltage Reference Fault					
Cause	Indication of controller internal voltage reference fault					
Trouble shooting	<p><u>Possible causes:</u></p> <ul style="list-style-type: none"> Defective power supply for main controller. Defective main controller. <p><u>Accompanied alarms:</u></p> <ul style="list-style-type: none"> There may be sensor alarms, AL 3XX. AL 801 will be activated during FT- or PTI test. <p><u>Trouble shooting:</u></p> <ol style="list-style-type: none"> Check if there are other active (sensor) alarms. Clear these alarms first using their trouble shooting. Check voltage level of 24 V DC and 5 V signals to see if power supply has an open circuit or other damages. If the correct voltage is measured at X22 and at X23 then circuit is defective. Replace main controller. 					
Criteria	Reference voltage AirEx above 5.50 V DC					
Controller action	None					
	Log	X	Alarm		Alarm light	Off
Consequence	Less accurate readings from measurement					
Elimination	Alarm will be marked as inactive in alarm list when supply voltage is correct. Alarm may then be deleted					
Log data	Parm 1	Parm 2	Parm 3	Parm 4	Parm 5	
	Active/Inactive	Low limit	High limit	Actual value	0	



971	Sensor bus sup LO					Warning
Description	Supply voltage sensor bus low					
Cause	Indication of controller voltage reference fault					
Trouble shooting	<p><u>Possible causes:</u></p> <ul style="list-style-type: none"> • Defective 12 V power supply on main controller. • Defective main controller. • Short circuit on sensor <p><u>Accompanied alarms:</u></p> <ul style="list-style-type: none"> • There may be sensor alarms (AL 730 and or 740) • AL 801 will be activated during FT- or PTI test. <p><u>Trouble shooting:</u></p> <ol style="list-style-type: none"> 1) Check if there are other active (sensor) alarms. Clear these alarms first using their trouble shooting. 2) Access the "special menu" by pressing  for more than 3 sec. Scroll down until you see the label "U sensor bus" in the display. The value of "U sensor bus" should be in the range between 11 and 14 V DC. 3) While displaying "U sensor bus", remove the connector on the RH cable at the first bus sensor (RH and or CO2 sensor). <ul style="list-style-type: none"> – If "U sensor bus" is now inside the correct above range (10 – 14 V DC), the RH and or CO2 sensor is defective. Replace the sensor(s) connected to sensor bus cable. – If "U sensor bus" is still outside the above range, proceed to next step. 4) While displaying "U sensor bus", disconnect sensor from the terminals according to wiring schematics inside in the control cabinet. <ul style="list-style-type: none"> – If "U sensor bus" is now inside the above range the cable for the RH and or CO2 sensor(s) is defective. Mount connector correctly or replace connector cable for RH and or CO2 sensor(s). – If the correct voltage is measured at X10 then circuit is defective. Replace the main controller. 					
Criteria	Reference voltage U sensor bus below 10 V DC					
Controller action	None					
	Log	X	Alarm		Alarm light	Off
Consequence						
Elimination						
Log data	Parm 1	Parm 2	Parm 3	Parm 4	Parm 5	
	Active/Inactive	Low limit	High limit	Actual value	0	



972	Sensor bus sup HI					Warning
Description	Controller Internal Voltage Reference Fault					
Cause	Indication of controller internal voltage reference fault					
Trouble shooting	<p><u>Possible causes:</u></p> <ul style="list-style-type: none"> Defective 12 V power supply on main controller. Defective main controller. Short circuit between 24 V DC and 12 V DC <p><u>Accompanied alarms:</u></p> <ul style="list-style-type: none"> There may be sensor alarms, AL 3XX. AL 801 will be activated during FT- or PTI test. <p><u>Trouble shooting:</u></p> <ol style="list-style-type: none"> Check if there are other active (sensor) alarms. Clear these alarms first using their trouble shooting. Check voltage level of 24 V DC and 12 V signals to see if power supply has an short circuit or other damages. If the correct voltage is measured at X10 then circuit is defective. Replace main controller. 					
Criteria	Reference voltage sensor bus above 14 V DC					
Controller action	None					
	Log	X	Alarm		Alarm light	Off
Consequence	Less accurate readings from measurement and damage to sensors					
Elimination	Alarm will be marked as inactive in alarm list when supply voltage is correct. Alarm may then be deleted					
Log data	Parm 1	Parm 2	Parm 3	Parm 4	Parm 5	
	Active/Inactive	Low limit	High limit	Actual value	0	



973	SUP6 SPM6 sup LO					Warning
Description	Supply voltage SUP6 SPM6 low					
Cause	Indication of controller voltage reference fault					
Trouble shooting	<p>Possible causes:</p> <ul style="list-style-type: none"> • Defective 12 V power supply to SUP6 or SMP6. • Defective main controller. • Short circuit on SUP6 SPM6 <p>Accompanied alarms:</p> <ul style="list-style-type: none"> • There may be sensor alarms (AL 302) • AL 801 will be activated during FT- or PTI test. <p>Trouble shooting:</p> <ol style="list-style-type: none"> 1) Check if there are other active (sensor) alarms (AL 971 and or AL 972) Clear these alarms first using their trouble shooting. 2) Access the "special menu" by pressing  for more than 3 sec. Scroll down until you see the label "SUP6 SPM6" in the display. The value of "U SUP6 SPM6" should be in the range between 11 and 14 V DC. 3) While displaying "U SUP6 SPM6", remove the connector at X9. <ul style="list-style-type: none"> – If "U SUP6 SPM6" is now inside the correct above range (11 – 14 V DC), the display and or power module is defective. Test with another display and or power module. – If "U SUP6 SPM6" is still outside the above range, proceed to next step. 4) While displaying "U SUP6 SPM6", disconnect display and or power module from the terminals according to wiring schematics inside in the control cabinet. <ul style="list-style-type: none"> – If "U SUP6 SPM6" is now inside the above range the cable for the display and or power module is defective. Mount connector correctly or replace connector cable for display and or power module. – If the correct voltage is measured at X11 then circuit is defective. Replace the main controller. 					
Criteria	Reference voltage U sensor bus below 10 V DC					
Controller action	None					
	Log	X	Alarm		Alarm light	Off
Consequence						
Elimination						
Log data	Parm 1	Parm 2	Parm 3	Parm 4	Parm 5	
	Active/Inactive	Low limit	High limit	Actual value	0	



974	Sensor bus sup HI					Warning
Description	Controller Internal Voltage Reference Fault					
Cause	Indication of controller internal voltage reference fault					
Trouble shooting	<p><u>Possible causes:</u></p> <ul style="list-style-type: none"> Defective 12 V power supply to sensor bus. Defective main controller. Short circuit between 24 V DC and 12 V DC <p><u>Accompanied alarms:</u></p> <ul style="list-style-type: none"> There may be sensor alarms, AL 3XX. AL 801 will be activated during FT- or PTI test. <p><u>Trouble shooting:</u></p> <ol style="list-style-type: none"> Check if there are other active (sensor) alarms. Clear these alarms first using their trouble shooting. Check voltage level of 24 V DC and 12 V signals to see if power supply has an short circuit or other damages. If the correct voltage is measured at X11 then circuit is defective. Replace main controller. 					
Criteria	Reference voltage sensor bus above 14 V DC					
Controller action	None					
	Log	X	Alarm		Alarm light	Off
Consequence	Less accurate readings from measurement and damage to sensors					
Elimination	Alarm will be marked as inactive in alarm list when supply voltage is correct. Alarm may then be deleted					
Log data	Parm 1	Parm 2	Parm 3	Parm 4	Parm 5	
	Active/Inactive	Low limit	High limit	Actual value	0	



975	Internal sup LO					Warning
Description	12 V supply voltage low on SMC6					
Cause	Indication of 12 V power supply fault					
Trouble shooting	<p><u>Possible causes:</u></p> <ul style="list-style-type: none"> Defective 12 V power supply on SMC6. Defective main controller. Short circuit on SUP6 and SPM6 or RH sensor and CO sensor <p><u>Accompanied alarms:</u></p> <ul style="list-style-type: none"> There may be sensor alarms (AL 302) AL 971 and or AL 973 AL 801 will be activated during FT- or PTI test. <p><u>Trouble shooting:</u></p> <ol style="list-style-type: none"> Check if there are other active (sensor) alarms (AL 971 and or AL 972) Clear these alarms first using their trouble shooting. (Future possibility) <p>Access the "special menu" by pressing  for more than 3 sec. Scroll down until you see the label "SUP6 SPM6" in the display. The value of "U SUP6 SPM6" should be in the range between 10 and 14 V DC.</p> While displaying "U SUP6 SPM6", remove the connector at X10. <ul style="list-style-type: none"> If "U SUP6 SPM6" is inside the correct range at X11 pin 1 and 4, the display and or power module is defective. Test with another display and or power module. If "U SUP6 SPM6" is still outside the above range, proceed to next step. While displaying "U SUP6 SPM6", disconnect RH at X10 and measure voltage. If not in-range, SMC6 may be defective or have insufficient supply at X1. If in-range, check SUP6 at X80 and SPM6 at X41. 					
Criteria	Internal power supply below 10 V DC					
Controller action	None					
	Log	X	Alarm		Alarm light	Off
Consequence	Less accurate readings from measurements.					
Elimination						
Log data	Parm 1	Parm 2	Parm 3	Parm 4	Parm 5	
	Active/Inactive	Low limit	High limit	Actual value	0	



976	Internal sup HI					Warning
Description	12 V supply voltage high on SMC6					
Cause	Indication of controller internal voltage reference fault					
Trouble shooting	<p><u>Possible causes:</u></p> <ul style="list-style-type: none"> Defective 12 V power supply. Defective main controller. Short circuit between 24 V DC and 12 V DC <p><u>Accompanied alarms:</u></p> <ul style="list-style-type: none"> There may be other alarms, AL 971 and AL 973 AL 801 will be activated during FT- or PTI test. <p><u>Trouble shooting:</u></p> <p>1) See trouble shooting for AL 974</p>					
Criteria	Internal power supply above 14 V DC					
Controller action	None					
	Log	X	Alarm		Alarm light	Off
Consequence	Less accurate readings from measurements and risk for damage to sensors					
Elimination	Alarm will be marked as inactive in alarm list when supply voltage is correct. Alarm may then be deleted					
Log data	Parm 1	Parm 2	Parm 3	Parm 4	Parm 5	
	Active/Inactive	Low limit	High limit	Actual value	0	

980	Tinternal LO					Warning
Description	Controller Internal Voltage Reference Fault					
Cause	Indication of controller internal voltage reference fault					
Trouble shooting	<p><u>Possible causes:</u></p> <ul style="list-style-type: none"> Defective power supply for main controller. Defective main controller. <p><u>Accompanied alarms:</u></p> <ul style="list-style-type: none"> AL 801 will be activated during FT- or PTI test. <p><u>Trouble shooting:</u></p> <p>1) Check if there are other active (sensor) alarms. Clear these alarms first using their trouble shooting.</p> <p>2) The main controller is defective. Replace the main controller.</p>					
Criteria	Internal temperature sensor below -40°C (-40°F)					
Controller action	None					
	Log	X	Alarm		Alarm light	Off
Consequence						
Elimination						
Log data	Parm 1	Parm 2	Parm 3	Parm 4	Parm 5	
	Active/Inactive	Low limit	High limit	Actual value	0	

The measured temperature is internal on the main controller and cannot be measured



981	Tinternal HI					Warning
Description	Controller Internal Temperature Sensor High Temperature Fault					
Cause	Indication of controller internal temperature sensor fault					
Trouble shooting	<p><u>Possible causes:</u></p> <ul style="list-style-type: none"> Defective power supply for main controller. Defective main controller. <p><u>Accompanied alarms:</u></p> <ul style="list-style-type: none"> AL 801 will be activated during FT- or PTI test. <p><u>Trouble shooting:</u></p> <ol style="list-style-type: none"> Check if there are other active (sensor) alarms. Clear these alarms first using their trouble shooting. Check voltage level of 24 V DC and 5 V signals to see if power supply has an open circuit or other damages. If voltages are OK, the main controller is defective. Replace main controller. 					
Criteria	Internal temperature sensor above +70°C (158°F)					
Controller action	None					
	Log	X	Alarm		Alarm light	Off
Consequence						
Elimination						
Log data	Parm 1	Parm 2	Parm 3	Parm 4	Parm 5	
	Active/Inactive	Low limit	High limit	Actual value	0	

The measured temperature is internal on the main controller and cannot be measured

988	Powermeas calibrat					Warning
Description	Powermeas calibration not possible					
Cause	Voltage difference between powermeas and frequency converter too large					
Trouble shooting	<p><u>Possible causes:</u></p> <ul style="list-style-type: none"> Defective powermeas Defective frequency converter. <p><u>Accompanied alarms:</u></p> <ul style="list-style-type: none"> AL 414, 415, 416, 417, 418, 419, 424, 425, 426, 427, 428 and 429 <p><u>Trouble shooting:</u></p> <ol style="list-style-type: none"> If there are other active alarms, check these first. Clear these alarms first using their trouble shooting. Measure the actual phase/phase voltages and check with the values in the display. If they are within +/- 30 V AC proceed to step 3) Set the unit in manual mode. Press and hold service key. Go to page 6 (Frequency converter) and check the Udc value. Take this value and divide it with 1.4142 and compare the result with the actual phase/phase voltage. If the voltage is not within +/- 20 V AC replace the FC. 					
Criteria	Difference between FC Udc voltage and voltage measurements from the power module PCB is too large. $Udc/1.4142=U1-2, U1-3$ and $U2-3$ within +/-50 V AC					
Controller action	Use old calibration value					
	Log	X	Alarm		Alarm light	Off
Consequence	None					



Elimination	Solve the issue according to Trouble Shooting guidelines and power cycle the controller				
Log data	Parm 1	Parm 2	Parm 3	Parm 4	Parm 5
	Active/Inactive	U1-2	U2-3	U1-3	Udc

989	Software test ver					Warning
Description	Software test version					
Cause	Indication of Software test version loading into controller					
Trouble shooting	<u>Possible causes:</u> <ul style="list-style-type: none"> • Test sw in the main controller. 					
	<u>Accompanied alarms:</u> <ul style="list-style-type: none"> • AL 801 will be activated during FT- or PTI test. 					
Trouble shooting	<u>Trouble shooting:</u> <ol style="list-style-type: none"> 1) There is a wrong sw version (test software) in the main controller. Update the software in the controller to the latest version. 2) If updated software is not accepted by the PCB, replace PCB. 					
Criteria						
Controller action	None					
	Log	X	Alarm	X	Alarm light	Off
Consequence						
Elimination	Replace software					
Log data	Parm 1	Parm 2	Parm 3	Parm 4	Parm 5	
	Active/Inactive					

990	Firmware update fail					Alarm
Description	Failed to activate firmware					
Cause	Hardware or operation miss match					
Trouble shooting	<u>Possible causes:</u> <ul style="list-style-type: none"> • Operating software is not compatible with hardware (SUP6, SMC6, SPM6) 					
	<u>Accompanied alarms:</u> <ul style="list-style-type: none"> • AL 996 and AL 997 will be activated during FT- or PTI test. 					
Trouble shooting	<u>Trouble shooting:</u> <ol style="list-style-type: none"> 1) Check if the software is to be used with unit. 2) Test the software with unit of the same type as the failing one. If software is running then see 3) 3) There is still a fault on either SUP6, SMC6, SPM6 					
Criteria						
Controller action	None					
	Log	X	Alarm	X	Alarm light	Slow flash
Consequence						
Elimination						
Log data	Parm 1	Parm 2	Parm 3	Parm 4	Parm 5	
	Active/Inactive	SMC6	SUP6	SPM6	SCC6	



991	Select model code					Warning
Description	Model code missing					
Cause	Installed software without model code					
Trouble shooting	<p><u>Possible causes:</u></p> <ul style="list-style-type: none"> • New software • New controller <p><u>Accompanied alarms:</u></p> <ul style="list-style-type: none"> • None <p><u>Trouble shooting:</u></p> <p>1) Go to service menu. Select configuration S05 and F10. Select model code according to Data Decal (placed on the unit)</p>					
Criteria	-					
Controller action	-					
	Log	X	Alarm		Alarm light	Off
Consequence						
Elimination						
Log data	Parm 1	Parm 2	Parm 3	Parm 4	Parm 5	
	-	-	-	-	-	

995	Replace ctrl. module					Fatal Alarm
Description	Controller module must be replaced					
Cause	Internal error on the main controller module which requires replacement					
Trouble shooting	<p><u>Possible causes:</u></p> <ul style="list-style-type: none"> • Internal memory error <p><u>Accompanied alarms:</u></p> <ul style="list-style-type: none"> • None <p><u>Trouble shooting:</u></p> <p>1) Replace controller module</p>					
Criteria	Type 0 (parameter 1 in the event log): Wrong dataflash page size					
Controller action	None					
	Log	X	Alarm	X	Alarm light	Quick flash
Consequence	Power cycle could lead to non operating controller. Possible corruption of datalog.					
Elimination	Replace main controller module					
Log data	Parm 1	Parm 2	Parm 3	Parm 4	Parm 5	
	Type (see above)	Type 0: Flash page size	-	-	-	



996	Software CRC error					Alarm
Description	Prom CRC Fault					
Cause						
Trouble shooting	<p><u>Possible causes:</u></p> <ul style="list-style-type: none"> Validity check of the program failed. <p><u>Accompanied alarms:</u></p> <ul style="list-style-type: none"> AL 801 will be activated during FT- or PTI test. <p><u>Trouble shooting:</u></p> <ol style="list-style-type: none"> There is a fault on the main controller. Update the software in the controller to the latest version. There is still a fault on the main controller. Replace the main controller. 					
Criteria						
Controller action	None					
	Log	X	Alarm	X	Alarm light	Slow flash
Consequence						
Elimination						
Log data	Parm 1	Parm 2	Parm 3	Parm 4	Parm 5	
	Active/Inactive	CRC sum	CRC check			

999	Keyboard Failure					Warning
Description	Indication of defective keyboard					
Cause	Keys on the keyboard pressed without user interaction					
Trouble shooting	<p><u>Possible causes:</u></p> <ul style="list-style-type: none"> Defective keyboard, defective user panel <p><u>Accompanied alarms:</u></p> <ul style="list-style-type: none"> AL 710 <p><u>Trouble shooting:</u></p> <ol style="list-style-type: none"> If any accompanied alarms are active, handle these first. Exchange the keyboard. Exchange the user panel. 					
Criteria	A key has been pressed for minimum 20 times during 1 hour					
Controller action	None					
	Log	X	Alarm	X	Alarm light	
Consequence	Menus can change automatically					
Elimination	Solve issue with trouble shooting guidelines					
Log data	Parm 1	Parm 2	Parm 3	Parm 4	Parm 5	
	Active/Inactive					



Calibration of air exchange sensor

Air exchange sensor calibration:

1. Close the fresh air cover plate.
2. In the "Service menu" line "F06 "Air exchange calibration" select "START" and press the "Enter button"
3. Calibration is done.

Sensor calibration using StarView

USDA and Cargo temperature probe offset adjustment.

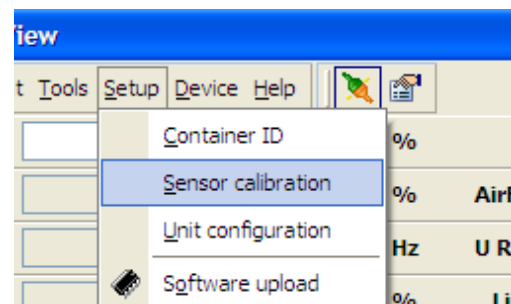

When placing the USDA and cargo probes in ice water, they should display 0° C. If any reading deviates from this value the probe requires calibration.

Calibration is simply done by looking at the reading for the USDA sensor and then double clicks in e.g. CalUs1. In the popup window enter the calibration value required in order for the sensor to reach 0° C. Then press enter. Do this calibration for each of the USDA and Cargo sensors. Max offset calibration is 3K. If more is required, the probe must be replaced.



Replacing of unit

Handling of SCU unit during replacement is done by means of a special yoke, see below sketch. Depending on the model, use either position 1, 2 or 3 for the yoke.

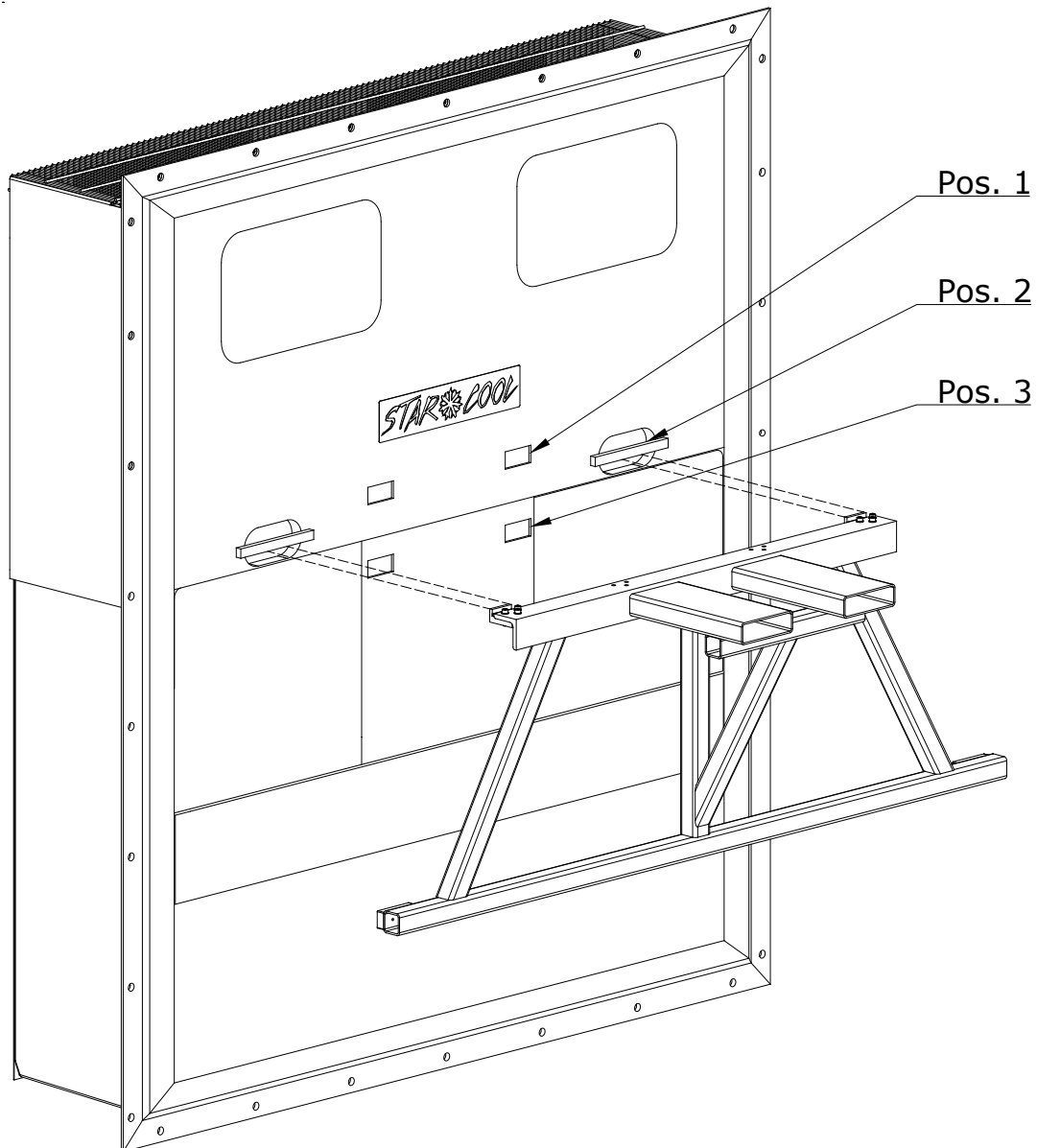



Replacement Evaporator motor and fan

Note: Turn off main power supply for unit before replacing evaporator motor and fan.
Note: Due to high aerodynamic requirements (decreased energy consumption) beware of sharp edges is located in this area!

Disconnect the power supply to the motor by removing the motor cover and unscrew the earth wire placed directly on the motor. Do not disconnect the other cable connection which is connected directly in the motor cover. Remove the 4 x M6 bolts that hold the evaporator motor bracket, incl. motor and fan.

Then the evaporator motor bracket with motor and fan can slide right through the inspection opening of the unit, by dragging it towards yourself.

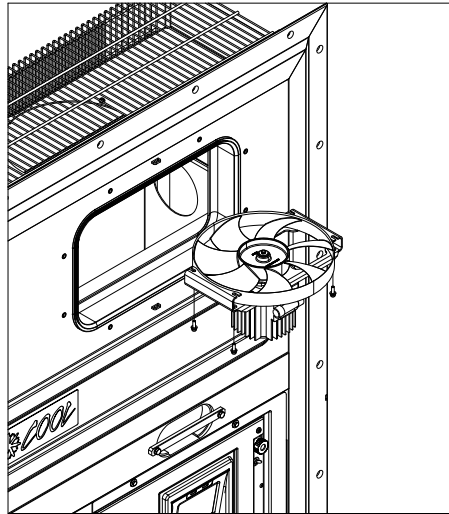
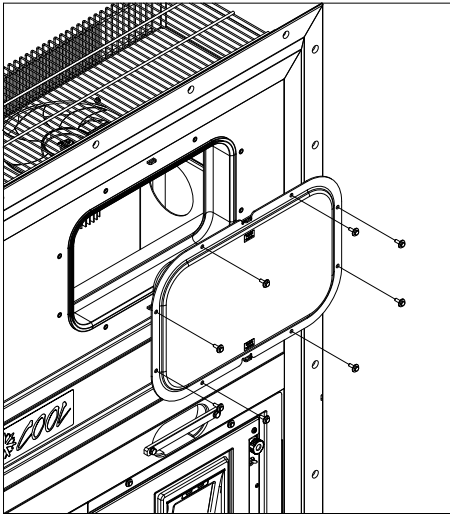

Replace the defective parts and reinstall the evaporator fan module.
 Prior to mounting the motor cover, check the sealing for any damages. If damaged, the sealing must be replaced.

Replacement Condenser motor and fan

Note: Turn off main power supply for unit before replacing condenser motor and fan.

Remove the condenser grill and disconnect the power supply to the motor by removing the motor cover and unscrew the earth wire, which is placed directly on the motor.

Do not disconnect the other cable connection which is connected directly in the motor cover.

Replace the defective parts and reinstall the parts.

Prior to mounting the motor cover, check the sealing for any damages, if damaged the sealing must be replaced.

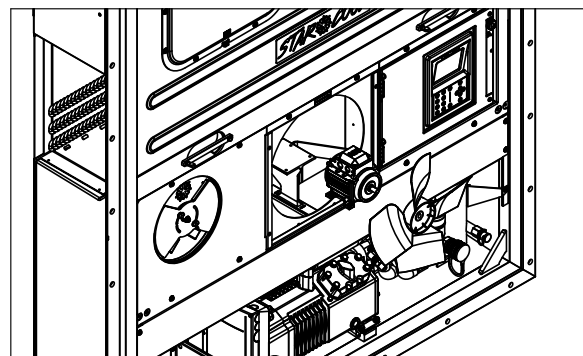
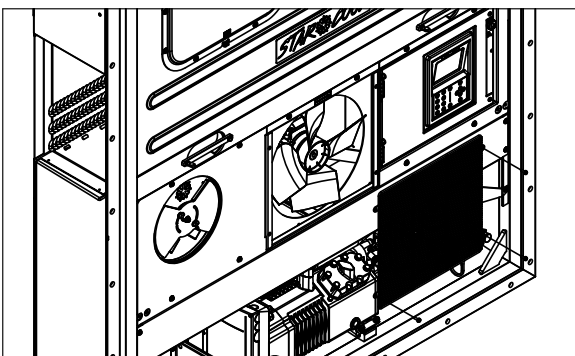



Replacement of evaporator

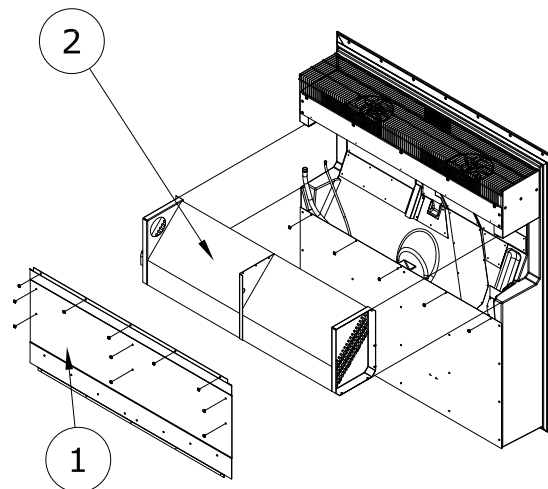

Position	Description
1	Back plate, unit
2	Evaporator

The replacing of evaporator is done in the following steps:

1. Evacuate refrigerant as described in this manual (see "Evacuation of refrigerant" p. 196)
2. Remove pos. 1.
3. Remove heating elements below pos. 2.
4. Remove the sensors for evaporator temperature / suction temperature / humidity.
5. Dismount / cut the suction and liquid pipe for pos. 2 on a proper place.
6. Remove / drill out rivets heads and remove pos. 2.
7. Punch the remaining rivet pieces into the foam using a (max $\varnothing 5$ mm) tool.
8. Mount new evaporator on chassis with appropriate rivets.
9. Connect the suction and liquid pipe to the new evaporator.
10. Reinstall the heating elements.
11. Reinstall the sensors for evaporator temperature / suction temperature / humidity.
12. Reinstall pos. 1.
13. Pump down the unit (see "Pump down of unit" p. 198)
14. Charge unit as described in this manual (see "Charging of refrigerant" p. 199)



Replacement of heating elements

Dismount the upper back plate for the unit and replace the defective heating element.

After replacing heating elements reinstall back plate for unit.

Please note that the illustrated model may be different from the actual model.

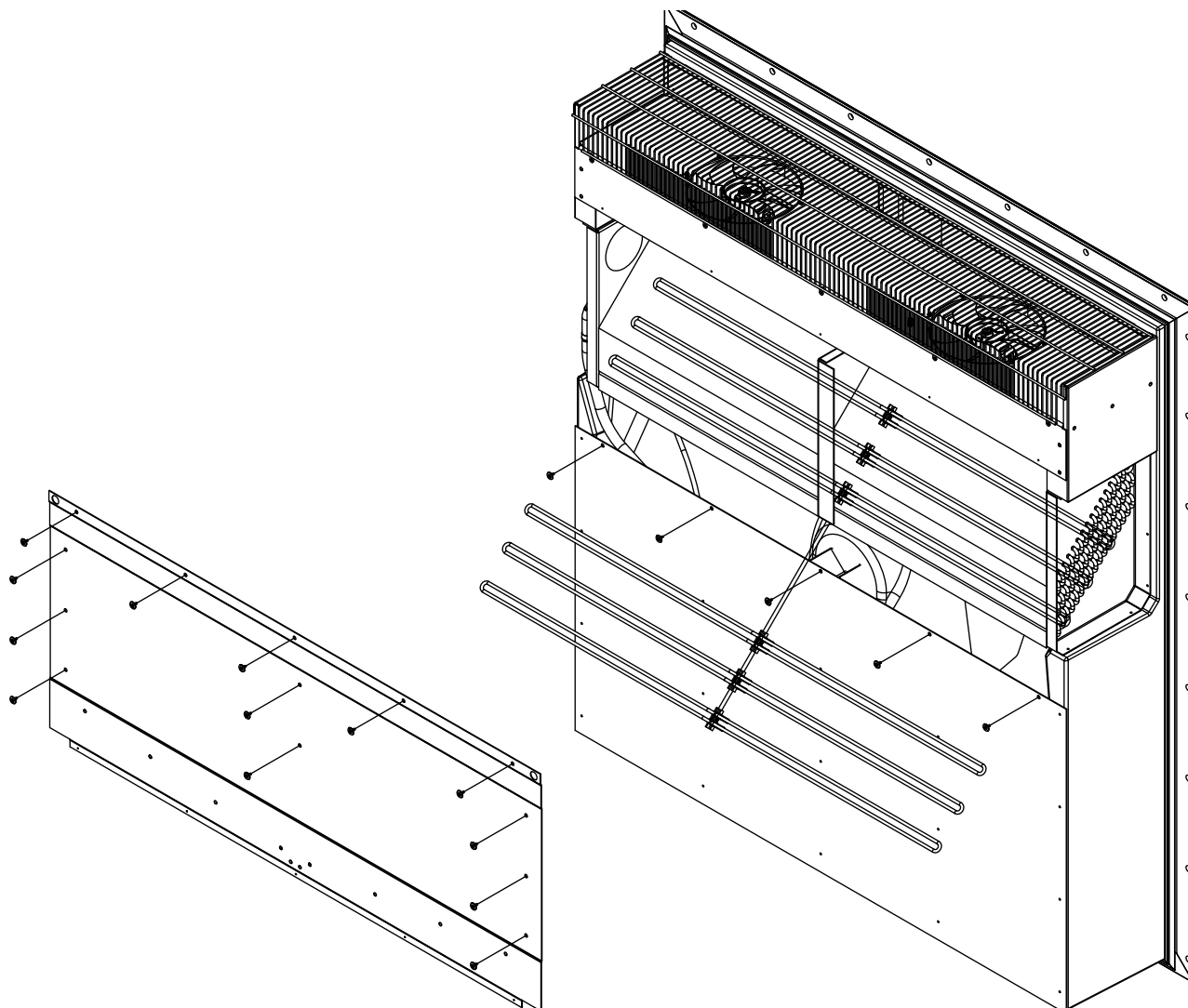



Replacement of FC

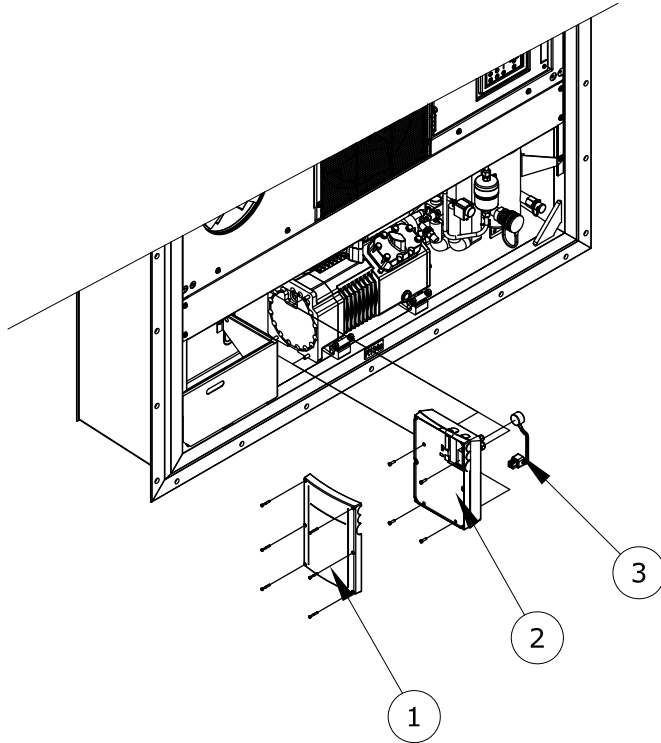

Position	Description
1	Cover for FC
2	FC
3	Motor cable

The procedure for replacing the FC is as follows:

(Please ensure correct tightening torque is used throughout replacement)

1. Remove the cover for FC, pos. 1.
2. Remove the FC, pos. 2 and motor cable, pos. 3.
3. Reinstall motor cable. Please observe that the motor cable is not damaged and squeezed between compressor and FC.
4. Mount new FC. Make sure that the FC is mounted correctly on the compressor and that there is no air gap between FC and compressor.
5. Reinstall cover for FC and cable room cover.



Replacement of compressor

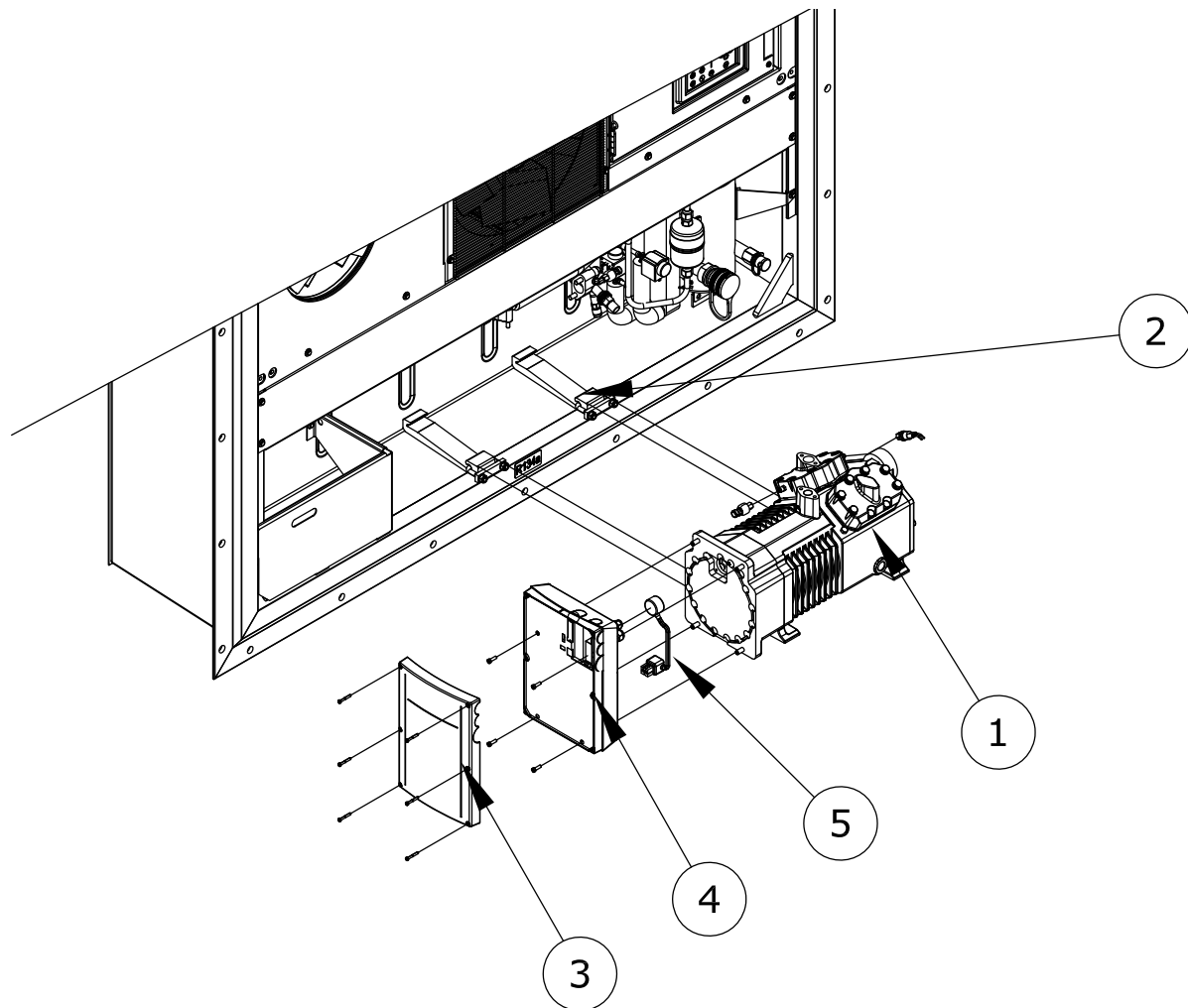

Position	Description
1	Compressor
2	Bracket for compressor
3	Cover for FC
4	FC
5	Motor cable

The procedure for replacing the compressor is as follows:

(Please ensure correct tightening torque is used throughout replacement)

If the compressor is NOT running, close all 3 stop valves and evacuate refrigerant, and proceed from pt. 1.

If the compressor IS running but needs replacement, complete the following before going to pt. 1.

- a. Close Veco and Vsuc
 - b. Go to service menu and enter the manual operation and set compressor freq to 20 Hz.
 - c. Let pressure drop to vacuum
 - d. Stop the compressor by pressing Off on the controller and close discharge stop valve.
 - e. Press wake up on the controller, and read pressure on display corner. Ensure it is 0 Bar.
1. Remove the cover for FC, pos. 3.
 2. Remove the FC, pos. 4 and motor cable, pos. 5.
 3. Dismount all pressure transmitters and high pressure switch.
 4. Loosen all bolts for compressor stop valves.
 5. Loosen bracket for compressor and turn it downwards.
 6. Slide compressor out.
 7. Slide new compressor in place. Observe that the rear compressor foot is inserted firmly into



the bracket slot.

8. Reinstall the compressor brackets.
9. Reinstall all pressure transmitters and high pressure switch.
10. Fasten all bolts for all 3 compressor stop valves.
11. Reinstall motor cable, please observe that the motor cable is not damaged and squeezed between compressor and FC.
12. Reinstall FC. Make sure that the FC is mounted correctly on the compressor and that there is no air gap between FC and compressor.
13. Reinstall cover for FC and cable room cover.
14. Evacuate the compressor before starting up, as described in this manual.

Replacement of compressor valve plate / cylinder head gasket

1. Depressurize the compressor.
2. Dismount cylinder head and valve plate (using a rubber mallet, if necessary). Carefully clean all sealing surfaces.
3. Check valve plate; Exchange entire valve plate if damaged. Determine the cause and eliminate it.
4. Mount the cylinder head, valve plate and new gaskets correctly. If located in an inconvenient mounting position, use mounting pins.
5. Tighten the bolts in the illustrated sequence in two steps. Starting with bolt no. 1 and no. 2 tightened firmly by hand, and then in sequence no. 3 to no. 10 by tightening torque: 70 Nm (see bolt numbers on fig. below).

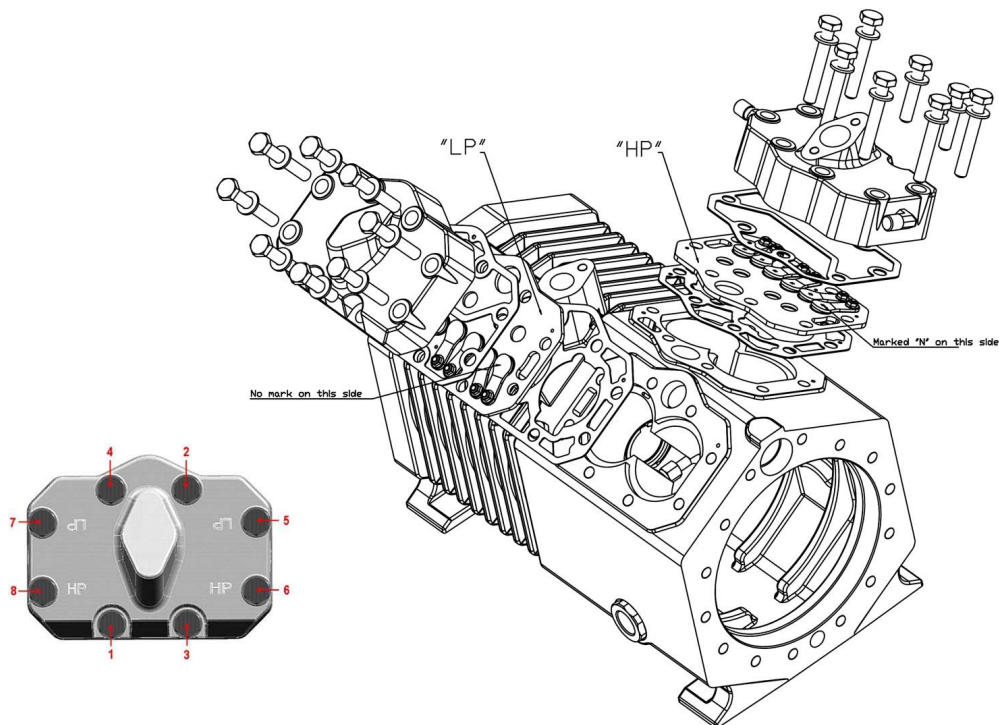



Service and maintenance

Evacuation of refrigerant

Evacuation of refrigerant for the unit is done by the following procedure:

1. Connect a service gauge manifold to the evacuation point, pos. 6 and 27 (P & I – diagram) on the compressor.
2. Connect a recovery unit to the gauge manifold.
 - a. Connect a recycling bottle to the recovery unit.
 - b. Use a scale underneath the bottle, for measuring the amount of recycled refrigerant.
3. Vapor recovery: If it is NOT possible to run the compressor.
 - a. Remove the electrical coils and install permanent magnet on the 3 valves pos. 16, 18 and 32 (P & I – diagram).
 - b. Turn off unit.
 - c. Close and open again, the discharge service valve pos. 5 (P & I – diagram) approx. 4 turns.
 - d. Check that the Recovery unit is set for "Vapor recovery".
 - e. Open both service gauge manifold valves (LP/HP).
Continue to 5.
4. Vapor recovery: If possible to run the compressor.
 - a. Continue operation on compressor.
 - b. Close service valve, economizer, pos. 14 (P & I diagram), from the receiver, and run a pump down of the LP side of the compressor to approx. -0.8 BarE
 - c. Turn off the compressor.
 - d. Close the suction service valve, pos. 26 (P & I diagram).
 - e. Check the Recovery unit is set for "Vapor recovery".
 - f. Remove the electrical coils and install permanent magnet on the 2 valves, pos. 16 and 18 (P & I diagram).
 - g. Open only the HP valve on the service gauge manifold.
5. Start and operate the recovery unit as long as necessary to evacuate desired amount of refrigerant from the unit, until no pressure left.
6. Open suction service valve fully.
7. Check the service gauge manifold, should be in slight vacuum.
8. Close all valves and stop the recovery unit; Evacuation done!

Note: refer to operating and service manuals for the recovery equipment.

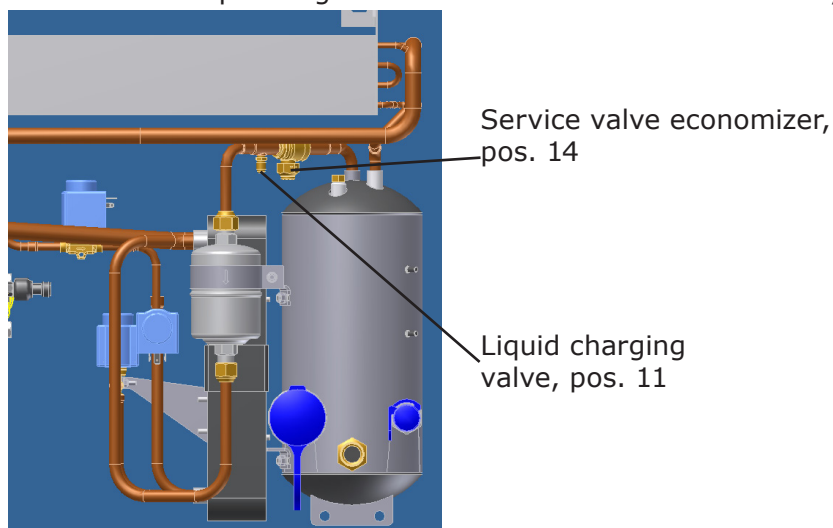

Compressor pump down, operation

Pump down of the compressor is done by the following procedure:

1. Connect a service gauge manifold to the two evacuation points, pos. 6 and 27 (P & I – dia-



- gram) on the compressor.
2. Connect a recovery unit to the gauge manifold
 - a. Connect a recycling bottle to the recovery unit
 - b. Use a scale underneath the bottle, for measuring the amount of recycled refrigerant.
3. Close the suction service valve and economizer suction service valve, pos. 26 and 30 (P & I – diagram).
4. Close the discharge service valve, pos. 5 (P & I diagram), approx. 4 turns.
5. Run the compressor in manual operation on 50 Hz, as described in “Manual operation” section.
6. Observe the LP indication: Until a vacuum of – 0.5 Bar/E (-7.3 Psi) has been reached.

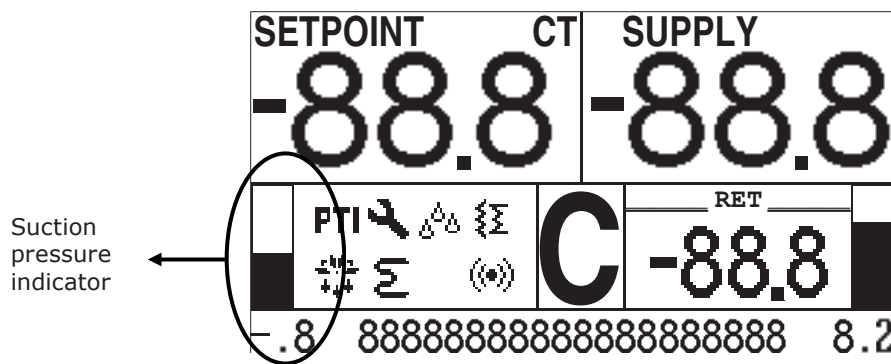

7. Turn of the compressor
8. Close the discharge service valve pos. 5 (P & I – diagram)
 - a. The evacuation points, pos. 6 and 27 (P & I – diagram), are open, when the service valves, pos. 5 and 26 (P & I – diagram), are closed.
9. Open the HP valve on the service gauge manifold.
10. Check that the Recovery unit are set for “Vapor recovery”.
11. Start and operate the recovery unit as long as necessary to evacuate the remaining pressure.
12. Check the service gauge manifold, should be in a slight vacuum.
13. After disconnecting evacuation unit, the compressor is now ready to be replaced.

Compressor pump down, replaced

Pump down of a new / replaced compressor is done by the following procedure:

1. Connect a vacuum pump with a service gauge manifold to the two evacuation points, pos. 6 and 27 (P & I – diagram).
2. Check that all service valves are still closed, pos. 5, 26 and 30 (P & I – diagram).
3. Pump down the ambient pressure in the compressor to a vacuum, indicated on the gauges of the service gauge manifold.
4. Continue vacuum – pumping for at least 2 hours. (Removing eventually moisture in the oil)
5. Close the service gauge manifold LP/HP valves.
6. Switch off the vacuum pump. (write down the vacuum reading, from the service gauge manifold.)
7. Observe the vacuum for minimum 0.5 hour.
8. If there has been no change in the vacuum, open all service valves, pos. 5, 26 and 30 (P & I – diagram)
9. If the vacuum is not maintained, there is a possible leak somewhere. Check all “service gauge manifold hoses”, connections, between compressor and vacuum pump. If these are OK, check the compressor & valves for leak.
10. Disconnect the service gauge manifold and operate the unit as normal.



Pump down of unit

Main power supply to unit shall be switched off during pump down of unit.

Pump down of unit is done by the following procedure:

1. Connect a service gauge manifold to the evacuation points, pos. 6 and 27 (P & I – diagram) on the compressor.
2. Connect a recovery unit to the gauge manifold.
 - 2a Connect a recycling bottle to the recovery unit.
 - 2b Use a scale underneath the bottle, for measuring the amount of recycled refrigerant.
3. Close (4 turns only), service valves, pos. 5 and 26 (P & I – diagram). (Pos. 30 still full open).
4. Replace the electrical coils with permanent magnet on pos. 16 and 18 (P & I – diagram).
5. Check that the Recovery unit is set for "Vapor recovery".
6. Open both service gauge manifold valves. (LP/HP)
7. Start and operate the recovery unit as long as necessary to evacuate desired amount of refrigerant from the unit, until there is no pressure left (slight vacuum)
8. Close the service gauge manifold LP/HP valves.
9. Connect a Vacuum pump – and start.
10. Open the service gauge manifold LP/HP valves
11. Continue vacuum – pumping for at least 2 hours.
12. Switch off the vacuum pump and close all service gauge manifold valves,
13. Observe the vacuum for minimum 0.5 hour.
14. If the vacuum is maintained, then the unit can be charged as described in this manual.
15. If the vacuum is not maintained, there is a possible leak somewhere.
 - 15a. Open all service valves complete pos. 5, 26 and 30 (P & I – diagram),
 - 15b. Start the vacuum pump, open all service gauge manifold valves run to max vacuum, (There is no connection to the unit, only your tools are checked)
 - 15c. Close only the service gauge manifold valve which connects the vacuum pump
 - 15d. Switch of the vacuum pump.
 - 15e. Observe the vacuum for minimum 0.5 hour, if the vacuum is OK, the SC unit has a leak!
 - 15f. Checking for leak – Please read "Pressure Test"

Pressure Test

After performing a major repair to the unit piping system, it is recommended to perform a pressure test.

Pressure test has the purpose of checking the piping system for leakages.

The pressure test is done by means of a high pressurized gas, ex. N₂, which is let into the piping system through the two evacuation points, pos. 6 and 27 (P & I – diagram). The procedure for this is as follows:

NOTE: DO NOT USE OXYGEN (O₂) FOR A PRESSURE TEST, BUT ONLY NITROGEN (N₂)

1. Install a service gauge manifold on the unit to the two evacuation points, pos. 6 and 27 (P & I – diagram).
2. Close the compressor discharge stopvalve and compressor suction stopvalve, pos. 5 and 26 (P & I– diagram), 4 turns.
3. Connect the pressurized gas bottle (ex. N₂) to the discharge stopvalve of the service gauge manifold.
4. Remove the electrical coils and mount permanent magnet on the two electronically expansion valves, pos. 16 and 18 (P & I – diagram).
5. Open the discharge stopvalve of the service gauge manifold.
6. Carefully open the hand valve of the pressurized gas bottle until the two gauges of the service gauge manifold show a pressure of 12 BarE.
7. Close the discharge stopvalve of the service gauge manifold.
8. Do a leakage detection as described in this manual.
9. Leave the unit pressurized for minimum 2 hours. If the pressure gauges still show 12 BarE after 2 hours, the unit is without any leakages.
10. If the pressure gauges are below 12 BarE, perform a leakage detection as described in this manual.



11. Disconnect the pressurized gas bottle.
12. Open the discharge stopvalve on the service gauge manifold to release the pressure from the unit.
13. Do a pump down of unit as described in this manual.
14. Charge the unit as described in this manual.

Charging of refrigerant

Charging of an empty unit

The power to the unit must be off.

The charging of an empty unit is done by weight, by the following procedure:

1. Pump down unit as described in this manual.
2. Open Discharge service valve complete pos. 5 (P & I – diagram).
3. Close HP valve on the service gauge manifold
4. Connect HP service gauge manifold to the Liquid charging valve pos. 11 (P & I – diagram).
5. Close Service valve economizer pos. 14 (P & I – diagram).
6. With installed service gauge manifold to the evacuation points, LP on: pos. 27 and HP on: Liquid charging valve pos. 11 (P & I – diagram).
7. Place a refrigerant bottle on a scale for weighing. Record the weight of the refrigerant bottle.
8. Connect manifold service hose to refrigerant bottle and purge as needed.
9. Set refrigerant bottle for liquid charging and open refrigerant bottle hand valve.
10. Check that service valve pos. 26 are fully open and 1 turn closed, (for service manifold gauge reading) (keep the manifold gauge LP valve closed)
11. Open the HP valve on the service gauge manifold slowly, only allowing liquid R134a to pass.
12. Observe the scale and close the hand valve located on the refrigerant bottle, when the correct amount of refrigerant has been charged. The refrigerant charge of the unit is: 4.5 kg R134a.
 - 8a. To speed up the charging time, it is recommended to start up the unit in manual mode, with a compressor speed not more than 20 Hz – until finishing charging.
13. Open Service valve economizer pos. 14 (P & I – diagram).
14. Close the valves on the service gauge manifold.
15. Open all the service valves "full", on the compressor, pos. 5, 26, and 30 (P & I – diagram).
16. Remove all tools again.
17. Make sure to install all valve cap's again.
18. Operate the unit as normal.

Note: If the correct amount of refrigerant is not charged by this procedure, follow the procedure described in charging of unit low on charge in this manual.

Charging of unit low on charge

If during normal stable in-range operation it is observed that the set-point temperature cannot be maintained it might be an indication of missing refrigerant. Please observe the unit for a period of at least 6 hours to ensure a stable tendency. During this observation time please observe the following:

1. The red balls in the sight glass for the receiver are constantly at bottom level.
2. Veco is more than (>) 80% open for 0.5 hour.
3. Vexp will steadily increase to 100%.
4. Psuc (T0) is steadily going down

If based on the above, it is determined that the unit is too low on refrigerant charge, additional refrigerant may be charged by following this procedure:



1. Install a service gauge manifold to the unit, and connect the HP hose to the Liquid charging line, pos. 11 (P & I – diagram) and the LP to the closed suction service valve. Pos 27 (P & I – diagram).
2. Connect the service gauge manifold to the refrigerant bottle with scale. Purge as needed.
3. Close the Service valve economizer pos. 14 (P & I – diagram).
4. Set the refrigerant bottle for liquid charging, and open the valve.
5. Open the LP service gauge manifold valve full, and check the refrigerant bottle pressure. (suction service valve pos 26 remain fully closed)
6. Operate the unit under normal condition, means it will pump down the LP.
7. Open the HP valve on the service gauge manifold to allow refrigerant to enter into the system.
8. Charge max. 0.5 kg (1 Lbs) (if there is a need for more – Check and repair the leak first!)
9. Close the refrigerant bottle valve.
10. Close the service gauge manifold valves and remove them!
11. Open the Service valve economizer pos. 14 (P & I – diagram).
12. Run the unit ½ h and check the R134a level in the receiver.
13. Make sure to install all valve caps again.

Caution: Do not overcharge the unit.

Leakage detection

Leakage detection is done under pressure test, as described in this manual.

While the unit is pressurized it is possible to check all soldered and screwed joints of the piping system. This is done with a leakage detection agent or with a solution with high foam building soap. The agent or water / soap solution is sprayed upon the joints. If there is a leakage bubbling, foam will occur. This leakage detection test can also be done while the unit is running charged with refrigerant by means of a refrigerant detector or soap solution. Leakage detection is also done during pump down of unit or compressor, as described in this manual.

Fan motors (in not using plug)

In order to prevent a single wire from getting caught between Ground screw and junction box cover, a cable tie collecting all wires except ground wire, needs to be placed in the center of the junction box. Furthermore is insulation tape applied on top of the Ground screw. This reduces the possibility of sharp edges on the top of the Ground Screw to damage nearby wiring.





Drying filter

Replacing of drying filter

Before replacing the drying filter, the power plug to the unit has to be disconnected.

The drying filter has to be changed every time the compressor is changed or if the moisture indicators indicate too much moisture is in the refrigerant circuit.

To change the drying filter, follow the following procedure:

1. Power off the unit.
2. Close the stop valve, pos. 14 (P & I – diagram).
3. Start the unit in "Manual" operation.
4. Select compressor frequency to 40 Hz.
5. Observe the Suction Pressure (Psuc). When Psuc = 0 BarE, power off the unit.
6. Carefully loosen the two union nuts for the drying filter.
Beware of pressurized escaping refrigerant. **Always wear protective goggles and gloves**
7. Replace the drying filter with a Danfoss DML 164 O - ring or equivalent.
Before mounting of the filter, put some drops of compressor ester oil on the flare in order to ensure correct tightness.
8. Tighten the two union nuts for the drying filter. See torque values in tables.
9. Remove the electrical coils and mount permanent magnet on the two electronically expansion valves, pos. 16 & 18 (P & I – diagram).
10. Carefully loosen the upper union nut for the drying filter, allowing a little amount of refrigerant gas to escape.
11. Tighten the union nut.
12. Remove the permanent magnets and reinstall the electrical coils on the two electronically expansion valves, pos. 16 & 18 (P & I – diagram).
13. Open the stop-valve, pos. 14 (P & I - diagram).
14. Power up the unit

Compressor

Check of oil level

The oil level can be checked on the sight glass of the compressor.

During normal operation the oil level should be between 1/3 and 2/3 sight glass full.

Normal operation is when the unit has been running on setpoint in a steady condition for minimum 6 hours. If the oil level is below sight glass after a period of minimum 6 hours' normal operation, additional oil may be added, as described in this manual

Note: Do not overfill the compressor with oil.

Check if the oil level of the compressor is equivalent to the oil level after running 6 hours at set point in a steady condition (1/3 to 2/3 sight glass full).

Due to dissolved refrigerant the oil level shown in the compressor sight glass may be too high if the unit has not been running for a longer period of time. In that case:

- Let the unit run for 20 minutes with set point below cargo set point.
- Turn off the compressor and check the sight glass.
- If the oil level is still too high, remove oil until 1/3 to 2/3 sight glass full is obtained.

In case the oil level is too low in the sight glass:

- Run the unit at a set point above the cargo set point for 20 minutes.
- Then let the unit run for 20 minutes above cargo set point.
- Turn off the compressor and check the sight glass.
- If the oil level is still too low, add oil until 1/3 to 2/3 sight glass full is obtained.



Charging of oil

If during normal operation it has been observed that there is too little oil charge on the compressor, additional oil may be charged.

The compressor is filled with 1,5 L Reniso Triton SEZ 55 or equivalent oil from the factory.

The procedure for adding oil is as follows:

1. Pump down the compressor, as described in this manual.
2. Remove plug on top of the stop valve for the intermediate pressure.
3. Start by adding 0.25 liter of compressor oil.
4. Reinstall plug on top of the stop valve for the intermediate pressure.
5. Evacuate the compressor as described in this manual
6. Open the compressor stopvalves, pos. 5, 26 and 30 (P & I – diagram).
7. Disconnect the vacuum pump.
8. Start up the unit.
9. Check the oil level during start up and after 6 hours in normal stable operation.
10. If oil is still missing, repeat above.

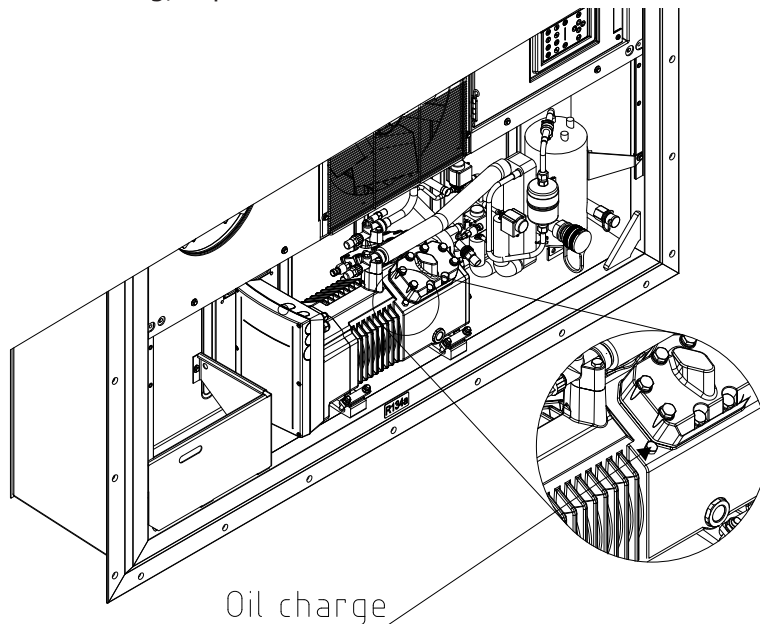

Draining of oil from compressor

If the compressor has been overcharged with oil, the procedure for drainage is as follows:

1. The two oil outlets are placed on a tee-piece located on the compressor end opposite of the FC end. Please observe that only one of the oil outlet ports is equipped with a schröder valve.
2. Connect a service gauge manifold to the outlet port with schröder valve of the oil pump.
3. Only connect the discharge hose to the outlet port of the oil pump.
Make sure that all stopvalves on the service gauge manifold are closed.
4. Open the discharge gauge stopvalve on the service gauge manifold.
5. Insert the hose from the suction gauge on the service gauge manifold into a small measuring cup.
6. Run the compressor in manual operation on 25 Hz.
7. Carefully open the suction gauge stopvalve on the service gauge manifold.
8. While observing the oil level in the sight glass of the compressor, carefully let out oil, until the oil level in the sight glass has reached a mid – level.
9. Close the suction gauge stopvalve and discharge gauge stopvalve on the service gauge manifold.
10. Disconnect the service gauge manifold.
11. Cap the oil outlet from the oil pump.
12. Set the controller to "AUTOMATIC" operation.
13. Run the unit in normal operation.
14. Observe the oil level when the unit is running minimum 6 hours in a stable condition.



Soldering

When soldering and desoldering components on the unit, please observe the following:

1. Use the following material for soldering:
 For Copper - Copper (all pipes):
 Soldering rod: L - Ag15P according to DIN 8513 or B - CuP5 according to AWS A 5.8.
 Example for product name: Chem - weld product 550 or Castolin RB 5283
 Soldering flux: Due to the high content of Phosphor in the soldering rod no flux is needed.
 For Copper - Stainless (connections for water cooled condenser and economizer):
 Soldering rod: L - Ag40Cd according to DIN 8513 or B - Ag 1 according to AWS A 5.8.
 Example for product name: Chem - weld product 511B or Castolin 1802 or 1802 F.
 Soldering flux: F - SH 1 according to DIN 8511 or FB 3A according to AWS A 5.31.
 Example for product name: Chem - weld product 110 or Castolin 1802
 N - Atmosin.
2. Use wet cloths to protect sensitive valves and other equipment against heat input during soldering and desoldering.
3. Use inert back gas as Nitrogen (N₂) during soldering and desoldering.

Welding

Do not perform welding on the unit before disconnecting the power plug. Furthermore, disconnect the power meas module and main controller (and modem if present).

Tables

Datalog description

Explanations of datalog loggings:

Temperatures are stored in °C and are converted to Fahrenheit on retrieval or listing on the display. Pressures are stored in BarE and are converted to Psi on retrieval.

The logged data in the data log can be seen:

- On the display menu L01, the viewable temperatures are listed.
- On the display menu L03, the logged temperatures can be viewed graphically.
- Retrieved via the program RefCon and the RMM modem and the powerline.
- Retrieved via a program, LogMan, on a PSION pda using the retriever socket.
- Retrieved via the StarView program using the retriever socket.

Data:

No.	Name	Value	Unit
1	Tsupply temperature	Temperature from supply sensor	°C
2	Treturn temperature	Temperature from return sensor	°C
3	Tusda 1 temperature	Temperature from USDA sensor 1	°C
4	Tusda 2 temperature	Temperature from USDA sensor 2	°C
5	Tusda 3 temperature	Temperature from USDA sensor 3	°C
6	Tcargo temperature	Temperature from cargo sensor	°C
7	Tset temperature	Set-point temperature	°C
8	Humidity %	Humidity from humidity sensor	%
9	AirEx airflow	Airflow from AirExchange sensor	m ³ /h



Extended data:

No.	Name	Value	Unit
1	Psuc pressure	Suction pressure (effective)	BarE
2	Pdis pressure	Discharge pressure (effective)	BarE
3	Fpower frequency	Power frequency	Hz
4	(Reserved)	--	--
5	Upower voltage	Highest power voltage of U1, U2, U3	V
No.	Name	Value	Unit
6	I1 current	Current I1	A
7	I2 current	Current I2	A
8	I3 current	Current I3	A
9	I _{fc} current	Current FC	A
10	Fcpr frequency	Compressor frequency	Hz
11	Heater status	Heater on-time	%
12	(Reserved)		--
13	Mevap status	Evaporator motor [OFF, LO, HI, ERR]	--
14	Mcond status	Condenser motor [OFF, LO, HI, ERR]	--
No.	Name	Value	Unit
15	T _{fc} temperature	Temperature of frequency controller	°C
16	T _{ambient} temperature	Ambient temperature [-30 - 96]	°C

Extended data 2 (only retrievable by StarView)

No.	Name	Value	Unit
1	T _{sup1}	Supply air temperature	°C
2	T _{sup2}	Supply air temperature	°C
3	T _{evap}	Evaporator temperature	°C
4	T _{suc}	Suction temperature	°C
5	V _{hg}	Hot gas valve opening	%
6	V _{exp}	Expansion valve opening	%
7	V _{eco}	Economizer valve opening	%
8	SH _{ref}	Super heat ref.	°C
9	T _{int}	Internal temp.	°C

Alarms:

Alarms which may occur and a detailed explanation and trouble shooting is described previously in this manual.



Temperature Sensor [°C] - Resistance Table

Resistance [Ω]	Temp [°C]	Resistance [Ω]	Temp [°C]	Resistance [Ω]	Temp [°C]	Resistance [Ω]	Temp [°C]	Resistance [Ω]	Temp [°C]
3,095,611.00	-70	138,322.00	-26	13,682.60	18	2,315.20	62	570.82	106
2,851,363.00	-69	130,243.00	-25	13,052.80	19	2,234.70	63	554.86	107
2,627,981.00	-68	122,687.00	-24	12,493.70	20	2,156.70	64	539.44	108
2,423,519.00	-67	115,613.00	-23	11,943.30	21	2,082.30	65	524.51	109
2,236,398.00	-66	108,991.00	-22	11,420.00	22	2,010.80	66	510.06	110
2,064,919.00	-65	102,787.00	-21	10,922.70	23	1,942.10	67	496.08	111
1,907,728.00	-64	96,974.00	-20	10,449.90	24	1,876.00	68	482.55	112
1,763,539.00	-63	91,525.00	-19	10,000.00	25	1,812.60	69	469.45	113
1,631,173.00	-62	86,415.00	-18	9,572.00	26	1,751.60	70	456.76	114
1,509,639.00	-61	81,621.00	-17	9,164.70	27	1,693.00	71	444.48	115
1,397,935.00	-60	77,121.00	-16	8,777.00	28	1,636.63	72	432.58	116
1,295,239.00	-59	72,895.00	-15	8,407.70	29	1,582.41	73	421.06	117
1,200,732.00	-58	68,927.00	-14	8,056.00	30	1,530.28	74	409.90	118
1,113,744.00	-57	65,198.00	-13	7,720.90	31	1,480.12	75	399.08	119
1,033,619.00	-56	61,693.00	-12	7,401.70	32	1,431.87	76	388.59	120
959,789.00	-55	58,397.00	-11	7,097.20	33	1,385.37	77	378.44	121
891,689.00	-54	55,298.00	-10	6,807.00	34	1,340.68	78	368.59	122
828,865.00	-53	52,380.00	-9	6,530.10	35	1,297.64	79	359.05	123
770,880.00	-52	49,663.00	-8	6,266.10	36	1,256.17	80	349.79	124
717,310.00	-51	47,047.00	-7	6,014.20	37	1,216.23	81	340.82	125
667,828.00	-50	44,610.00	-6	5,773.70	38	1,177.75	82	332.11	126
622,055.00	-49	42,314.60	-5	5,544.10	39	1,140.71	83	323.67	127
579,718.00	-48	40,149.50	-4	5,324.90	40	1,104.99	84	315.48	128
540,530.00	-47	38,108.50	-3	5,115.60	41	1,070.58	85	307.53	129
504,230.00	-46	36,182.80	-2	4,915.50	42	1,037.40	86	299.82	130
470,609.00	-45	34,366.10	-1	4,724.30	43	1,005.40	87	292.34	131
439,445.00	-44	32,650.80	0	4,541.60	44	974.56	88	285.08	132
410,532.00	-43	31,030.40	1	4,366.90	45	944.81	89	278.03	133
383,712.00	-42	29,500.10	2	4,199.90	46	916.11	90	271.19	134
358,806.00	-41	28,054.20	3	4,040.10	47	888.41	91	264.54	135
335,671.00	-40	26,687.60	4	3,887.20	48	861.70	92	258.09	136
314,179.00	-39	25,395.50	5	3,741.10	49	835.93	93	251.82	137
294,193.00	-38	24,172.70	6	3,601.00	50	811.03	94	245.74	138
275,605.00	-37	23,016.00	7	3,466.90	51	786.99	95	239.82	139
258,307.00	-36	21,921.70	8	3,338.60	52	763.79	96	234.08	140
242,195.00	-35	20,885.20	9	3,215.60	53	741.38	97	228.50	141
227,196.00	-34	19,903.50	10	3,097.90	54	719.74	98	223.08	142
213,219.00	-33	18,973.60	11	2,985.10	55	698.82	99	217.80	143
200,184.00	-32	18,092.60	12	2,876.90	56	678.63	100	212.68	144
188,026.00	-31	17,257.40	13	2,773.20	57	659.10	101	207.70	145
176,683.00	-30	16,465.10	14	2,673.90	58	640.23	102	202.86	146
166,091.00	-29	15,714.00	15	2,578.50	59	622.00	103	198.15	147
156,199.00	-28	15,001.20	16	2,487.10	60	604.36	104	193.57	148
146,959.00	-27	14,324.60	17	2,399.40	61	587.31	105	189.12	149



Temperature Sensor [°F] - Resistance Table

Resistance [Ω]	Temp [°F]	Resistance [Ω]	Temp [°F]	Resistance [Ω]	Temp [°F]	Resistance [Ω]	Temp [°F]	Resistance [Ω]	Temp [°F]
3,095,611.00	-94	138,322.00	-15	13,682.60	64	2,315.20	144	570.82	223
2,851,363.00	-92	130,243.00	-13	13,052.80	66	2,234.70	145	554.86	225
2,627,981.00	-90	122,687.00	-11	12,493.70	68	2,156.70	147	539.44	226
2,423,519.00	-89	115,613.00	-9	11,943.30	70	2,082.30	149	524.51	228
2,236,398.00	-87	108,991.00	-8	11,420.00	72	2,010.80	151	510.06	230
2,064,919.00	-85	102,787.00	-6	10,922.70	73	1,942.10	153	496.08	232
1,907,728.00	-83	96,974.00	-4	10,449.90	75	1,876.00	154	482.55	234
1,763,539.00	-81	91,525.00	-2	10,000.00	77	1,812.60	156	469.45	235
1,631,173.00	-80	86,415.00	0	9,572.00	79	1,751.60	158	456.76	237
1,509,639.00	-78	81,621.00	1	9,164.70	81	1,693.00	160	444.48	239
1,397,935.00	-76	77,121.00	3	8,777.00	82	1,636.63	162	432.58	241
1,295,239.00	-74	72,895.00	5	8,407.70	84	1,582.41	163	421.06	243
1,200,732.00	-72	68,927.00	7	8,056.00	86	1,530.28	165	409.90	244
1,113,744.00	-71	65,198.00	9	7,720.90	88	1,480.12	167	399.08	246
1,033,619.00	-69	61,693.00	10	7,401.70	90	1,431.87	169	388.59	248
959,789.00	-67	58,397.00	12	7,097.20	91	1,385.37	171	378.44	250
891,689.00	-65	55,298.00	14	6,807.00	93	1,340.68	172	368.59	252
828,865.00	-63	52,380.00	16	6,530.10	95	1,297.64	174	359.05	253
770,880.00	-62	49,663.00	18	6,266.10	97	1,256.17	176	349.79	255
717,310.00	-60	47,047.00	19	6,014.20	99	1,216.23	178	340.82	257
667,828.00	-58	44,610.00	21	5,773.70	100	1,177.75	180	332.11	259
622,055.00	-56	42,314.60	23	5,544.10	102	1,140.71	181	323.67	261
579,718.00	-54	40,149.50	25	5,324.90	104	1,104.99	183	315.48	262
540,530.00	-53	38,108.50	27	5,115.60	106	1,070.58	185	307.53	264
504,230.00	-51	36,182.80	28	4,915.50	108	1,037.40	187	299.82	266
470,609.00	-49	34,366.10	30	4,724.30	109	1,005.40	189	292.34	268
439,445.00	-47	32,650.80	32	4,541.60	111	974.56	190	285.08	270
410,532.00	-45	31,030.40	34	4,366.90	113	944.81	192	278.03	271
383,712.00	-44	29,500.10	36	4,199.90	115	916.11	194	271.19	273
358,806.00	-42	28,054.20	37	4,040.10	117	888.41	196	264.54	275
335,671.00	-40	26,687.60	39	3,887.20	118	861.70	198	258.09	277
314,179.00	-38	25,395.50	41	3,741.10	120	835.93	199	251.82	279
294,193.00	-36	24,172.70	43	3,601.00	122	811.03	201	245.74	280
275,605.00	-35	23,016.00	45	3,466.90	124	786.99	203	239.82	282
258,307.00	-33	21,921.70	46	3,338.60	126	763.79	205	234.08	284
242,195.00	-31	20,885.20	48	3,215.60	127	741.38	207	228.50	286
227,196.00	-29	19,903.50	50	3,097.90	129	719.74	208	223.08	288
213,219.00	-27	18,973.60	52	2,985.10	131	698.82	210	217.80	289
200,184.00	-26	18,092.60	54	2,876.90	133	678.63	212	212.68	291
188,026.00	-24	17,257.40	55	2,773.20	135	659.10	214	207.70	293
176,683.00	-22	16,465.10	57	2,673.90	136	640.23	216	202.86	295
166,091.00	-20	15,714.00	59	2,578.50	138	622.00	217	198.15	297
156,199.00	-18	15,001.20	61	2,487.10	140	604.36	219	193.57	298
146,959.00	-17	14,324.60	63	2,399.40	142	587.31	221	189.12	300



Air exchange Sensor table Voltage - m3/h for 35 CMH

There is an offset of 0.2 V due to mechanical design. The air exchange must be properly calibrated before measuring.

Voltage [V]	Air exchange [m3/h]	Voltage [V]	Air exchange [m3/h]	Voltage [V]	Air exchange [m3/h]	Voltage [V]	Air exchange [m3/h]
0.20	0	1.45	60	2.25	120	3.35	180
0.30	5	1.50	65	2.35	125	3.40	185
0.50	10	1.55	70	2.40	130	3.50	190
0.65	15	1.65	75	2.50	135	3.60	195
0.80	20	1.70	80	2.55	140	3.65	200
0.85	25	1.75	85	2.65	145	3.80	205
0.95	30	1.90	90	2.70	150	3.85	210
1.05	35	1.95	95	2.80	155	3.95	215
1.15	40	2.00	100	2.90	160	4.00	220
1.20	45	2.05	105	3.00	165		
1.30	50	2.10	110	3.10	170		
1.35	55	2.20	115	3.20	175		

Air exchange Sensor table Voltage - m3/h for 75 CMH

Voltage [V]	Air exchange [m3/h]	Voltage [V]	Air exchange [m3/h]	Voltage [V]	Air exchange [m3/h]	Voltage [V]	Air exchange [m3/h]
0.20	10	1.50	90	2.65	155	3.65	220
0.35	20	1.60	95	2.70	160	3.70	225
0.50	30	1.70	100	2.80	165	3.75	230
0.65	35	1.80	105	2.85	170	3.80	235
0.75	40	1.90	110	2.95	175	3.90	240
0.85	45	2.00	115	3.00	180	3.95	245
1.00	50	2.10	120	3.10	185	4.00	250
1.10	60	2.25	130	3.25	195		
1.20	65	2.35	135	3.35	200		
1.30	75	2.40	140	3.40	205		
1.35	80	2.45	145	3.50	210		
1.45	85	2.55	150	3.55	215		



Voltage – Pressure Table, Low pressure transmitter (AKS)

Vcc = 5 V. Pressure is relative

Voltage [V]	Pressure [BarE]	Pressure [Psi]	Voltage [V]	Pressure [BarE]	Pressure [Psi]
0.50	-1.000	-14.50	2.55	5.663	82.13
0.55	-0.838	-12.15	2.60	5.825	84.48
0.60	-0.675	-9.79	2.65	5.988	86.85
0.65	-0.513	-7.44	2.70	6.150	89.20
0.70	-0.350	-5.08	2.75	6.313	91.56
0.75	-0.188	-2.73	2.80	6.475	93.91
0.80	-0.025	-0.36	2.85	6.638	96.28
0.85	0.138	2.00	2.90	6.800	98.63
0.90	0.300	4.35	2.95	6.963	100.99
0.95	0.463	6.72	3.00	7.125	103.34
1.00	0.625	9.06	3.05	7.288	105.70
1.05	0.788	11.43	3.10	7.450	108.05
1.10	0.950	13.78	3.15	7.613	110.42
1.15	1.113	16.14	3.20	7.775	112.77
1.20	1.275	18.49	3.25	7.938	115.13
1.25	1.438	20.86	3.30	8.100	117.48
1.30	1.600	23.21	3.35	8.263	119.84
1.35	1.763	25.57	3.40	8.425	122.19
1.40	1.925	27.92	3.45	8.588	124.56
1.45	2.088	30.28	3.50	8.750	126.91
1.50	2.250	32.63	3.55	8.913	129.27
1.55	2.413	35.00	3.60	9.075	131.62
1.60	2.575	37.35	3.65	9.238	133.99
1.65	2.738	39.71	3.70	9.400	136.34
1.70	2.900	42.06	3.75	9.563	138.70
1.75	3.063	44.43	3.80	9.725	141.05
1.80	3.225	46.77	3.85	9.888	143.41
1.85	3.388	49.14	3.90	10.050	145.76
1.90	3.550	51.49	3.95	10.213	148.13
1.95	3.713	53.85	4.00	10.375	150.48
2.00	3.875	56.20	4.05	10.538	152.84
2.05	4.038	58.57	4.10	10.700	155.19
2.10	4.200	60.92	4.15	10.863	157.55
2.15	4.363	63.28	4.20	11.025	159.90
2.20	4.525	65.63	4.25	11.188	162.27
2.25	4.688	67.99	4.30	11.350	164.62
2.30	4.850	70.34	4.35	11.513	166.98
2.35	5.013	72.71	4.40	11.675	169.33
2.40	5.175	75.06	4.45	11.838	171.70
2.45	5.338	77.42	4.50	12.000	174.05
2.50	5.500	79.77			



Voltage – Pressure Table, Low pressure transmitter (NSK)

Vcc = 5 V. Pressure is relative

Voltage [V]	Pressure [BarE]	Pressure [Psi]	Voltage [V]	Pressure [BarE]	Pressure [Psi]
	-0,69	-10,01	1,9	4,57	66,34
0,3	-0,65	-9,49	1,95	4,74	68,71
0,35	-0,49	-7,12	2	4,90	71,08
0,4	-0,33	-4,75	2,05	5,06	73,45
0,45	-0,16	-2,38	2,1	5,23	75,82
0,5	0,00	-0,01	2,15	5,39	78,19
0,55	0,16	2,36	2,2	5,55	80,56
0,6	0,33	4,73	2,25	5,72	82,93
0,65	0,49	7,10	2,3	5,88	85,30
0,7	0,65	9,47	2,35	6,04	87,67
0,75	0,82	11,84	2,4	6,21	90,04
0,8	0,98	14,21	2,45	6,37	92,41
0,85	1,14	16,58	2,5	6,53	94,78
0,9	1,31	18,95	2,55	6,70	97,15
0,95	1,47	21,32	2,6	6,86	99,52
1	1,63	23,69	2,65	7,02	101,89
1,05	1,80	26,06	2,7	7,19	104,26
1,1	1,96	28,43	2,75	7,35	106,63
1,15	2,12	30,80	2,8	7,51	109,00
1,2	2,29	33,17	2,85	7,68	111,37
1,25	2,45	35,54	2,9	7,84	113,74
1,3	2,61	37,91	2,95	8,00	116,11
1,35	2,78	40,28	3	8,17	118,48
1,4	2,94	42,65	3,05	8,33	120,85
1,45	3,10	45,02	3,1	8,49	123,22
1,5	3,27	47,39	3,15	8,66	125,59
1,55	3,43	49,76	3,2	8,82	127,96
1,6	3,59	52,13	3,25	8,98	130,33
1,65	3,76	54,50	3,3	9,15	132,70
1,7	3,92	56,87	3,35	9,31	135,07
1,75	4,08	59,24	3,4	9,47	137,44
1,8	4,25	61,61	3,45	9,64	139,81
1,85	4,41	63,97	3,5	9,80	142,18



Voltage – Pressure Table, High pressure transmitter (AKS)

Vcc = 5 V. Pressure is relative

Voltage [V]	Pressure [BarE]	Pressure [Psi]	Voltage [V]	Pressure [BarE]	Pressure [Psi]
0.50	0.00	0.00	2.55	16.40	237.86
0.55	0.40	5.80	2.60	16.80	243.66
0.60	0.80	11.60	2.65	17.20	249.46
0.65	1.20	17.40	2.70	17.60	255.27
0.70	1.60	23.21	2.75	18.00	261.07
0.75	2.00	29.01	2.80	18.40	266.87
0.80	2.40	34.81	2.85	18.80	272.67
0.85	2.80	40.61	2.90	19.20	278.47
0.90	3.20	46.41	2.95	19.60	284.27
0.95	3.60	52.21	3.00	20.00	290.08
1.00	4.00	58.02	3.05	20.40	295.88
1.05	4.40	63.82	3.10	20.80	301.68
1.10	4.80	69.62	3.15	21.20	307.48
1.15	5.20	75.42	3.20	21.60	313.28
1.20	5.60	81.22	3.25	22.00	319.08
1.25	6.00	87.02	3.30	22.40	324.88
1.30	6.40	92.82	3.35	22.80	330.69
1.35	6.80	98.63	3.40	23.20	336.49
1.40	7.20	104.43	3.45	23.60	342.29
1.45	7.60	110.23	3.50	24.00	348.09
1.50	8.00	116.03	3.55	24.40	353.89
1.55	8.40	121.83	3.60	24.80	359.69
1.60	8.80	127.63	3.65	25.20	365.50
1.65	9.20	133.43	3.70	25.60	371.30
1.70	9.60	139.24	3.75	26.00	377.10
1.75	10.00	145.04	3.80	26.40	382.90
1.80	10.40	150.84	3.85	26.80	388.70
1.85	10.80	156.64	3.90	27.20	394.50
1.90	11.20	162.44	3.95	27.60	400.30
1.95	11.60	168.24	4.00	28.00	406.11
2.00	12.00	174.05	4.05	28.40	411.91
2.05	12.40	179.85	4.10	28.80	417.71
2.10	12.80	185.65	4.15	29.20	423.51
2.15	13.20	191.45	4.20	29.60	429.31
2.20	13.60	197.25	4.25	30.00	435.11
2.25	14.00	203.05	4.30	30.40	440.91
2.30	14.40	208.85	4.35	30.80	446.72
2.35	14.80	214.66	4.40	31.20	452.52
2.40	15.20	220.46	4.45	31.60	458.32
2.45	15.60	226.26	4.50	32.00	464.12
2.50	16.00	232.06			



Voltage – Pressure Table, High pressure transmitter (NSK)

Vcc = 5 V. Pressure is relative

Voltage [V]	Pressure [BarE]	Pressure [Psi]	Voltage [V]	Pressure [BarE]	Pressure [Psi]
0,5	0,00	0	2,05	15,50	224,874
0,55	0,50	7,254	2,1	16,00	232,128
0,6	1,00	14,508	2,15	16,50	239,382
0,65	1,50	21,762	2,2	17,00	246,636
0,7	2,00	29,016	2,25	17,50	253,89
0,75	2,50	36,27	2,3	18,00	261,144
0,8	3,00	43,524	2,35	18,50	268,398
0,85	3,50	50,778	2,4	19,00	275,652
0,9	4,00	58,032	2,45	19,50	282,906
0,95	4,50	65,286	2,5	20,00	290,16
1	5,00	72,54	2,55	20,50	297,414
1,05	5,50	79,794	2,6	21,00	304,668
1,1	6,00	87,048	2,65	21,50	311,922
1,15	6,50	94,302	2,7	22,00	319,176
1,2	7,00	101,556	2,75	22,50	326,43
1,25	7,50	108,81	2,8	23,00	333,684
1,3	8,00	116,064	2,85	23,50	340,938
1,35	8,50	123,318	2,9	24,00	348,192
1,4	9,00	130,572	2,95	24,50	355,446
1,45	9,50	137,826	3	25,00	362,7
1,5	10,00	145,08	3,05	25,50	369,954
1,55	10,50	152,334	3,1	26,00	377,208
1,6	11,00	159,588	3,15	26,50	384,462
1,65	11,50	166,842	3,2	27,00	391,716
1,7	12,00	174,096	3,25	27,50	398,97
1,75	12,50	181,35	3,3	28,00	406,224
1,8	13,00	188,604	3,35	28,50	413,478
1,85	13,50	195,858	3,4	29,00	420,732
1,9	14,00	203,112	3,45	29,50	427,986
1,95	14,50	210,366	3,5	30,00	435,24
2	15,00	217,62			



Temperature Sensor - Voltage Table

Temperature sensors except for reference temperature sensor.

V_{cc} = 5 V

Voltage [V]	Temp [°C]	Temp [°F]	Voltage [V]	Temp [°C]	Temp [°F]	Voltage [V]	Temp [°C]	Temp [°F]
3.00	-40	-40.0	2.03	-9	15.8	0.85	22	71.6
2.98	-39	-38.2	1.98	-8	17.6	0.82	23	73.4
2.97	-38	-36.4	1.94	-7	19.4	0.79	24	75.2
2.95	-37	-34.6	1.89	-6	21.2	0.77	25	77.0
2.92	-36	-32.8	1.85	-5	23.0	0.74	26	78.8
2.90	-35	-31.0	1.81	-4	24.8	0.72	27	80.6
2.88	-34	-29.2	1.77	-3	26.6	0.69	28	82.4
2.86	-33	-27.4	1.73	-2	28.4	0.67	29	84.2
2.83	-32	-25.6	1.68	-1	30.2	0.65	30	86.0
2.81	-31	-23.8	1.64	0	32.0	0.63	31	87.8
2.78	-30	-22.0	1.60	1	33.8	0.61	32	89.6
2.75	-29	-20.2	1.56	2	35.6	0.58	33	91.4
2.73	-28	-18.4	1.52	3	37.4	0.57	34	93.2
2.69	-27	-16.6	1.48	4	39.2	0.55	35	95.0
2.67	-26	-14.8	1.43	5	41.0	0.53	36	96.8
2.63	-25	-13.0	1.39	6	42.8	0.51	37	98.6
2.60	-24	-11.2	1.35	7	44.6	0.49	38	100.4
2.57	-23	-9.4	1.32	8	46.4	0.48	39	102.2
2.53	-22	-7.6	1.28	9	48.2	0.46	40	104.0
2.49	-21	-5.8	1.24	10	50.0	0.44	41	105.8
2.46	-20	-4.0	1.21	11	51.8	0.43	42	107.6
2.42	-19	-2.2	1.17	12	53.6	0.42	43	109.4
2.39	-18	-0.4	1.14	13	55.4	0.40	44	111.2
2.35	-17	1.4	1.10	14	57.2	0.38	45	113.0
2.31	-16	3.2	1.06	15	59.0	0.37	46	114.8
2.27	-15	5.0	1.03	16	60.8	0.36	47	116.6
2.23	-14	6.8	1	17	62.6	0.35	48	118.4
2.19	-13	8.6	0.97	18	64.4	0.34	49	120.2
2.15	-12	10.4	0.94	19	66.2	0.32	50	122.0
2.11	-11	12.2	0.90	20	68.0			
2.07	-10	14.0	0.88	21	69.8			



Pressure/Temperature table for R134a

°F	°C	Bar	Psi
-40	-40	-0,5	-7.3
-36	-38	-0,45	-6.5
-33	-36	-0,38	-5.6
-29	-34	-0,32	-4.6
-26	-32	-0,25	-3.6
-22	-30	-0,17	-2.5
-18	-28	-0,09	-1.3
-15	-26	0	0
-11	-24	0,1	1.4
-8	-22	0,2	2.9
-4	-20	0,31	4.6
-0,4	-18	0,43	6.3
3	-16	0,56	8.1
7	-14	0,69	10.1
10	-12	0,84	12.2
14	-10	0,99	14.4
18	-8	1,16	16.8
21	-6	1,33	19.3
25	-4	1,51	21.9
28	-2	1,71	24.8
32	0	1,91	27.8
36	2	2,13	30.9
39	4	2,36	34.3
43	6	2,61	37.8
46	8	2,86	41.5
50	10	3,13	45.4
54	12	3,42	49.6
57	14	3,72	53.9
61	16	4,03	58.4
64	18	4,36	63.2

°F	°C	Bar	Psi
68	20	4,7	68.2
72	22	5,07	73.5
75	24	5,44	79
79	26	5,84	84.7
82	28	6,26	90.7
86	30	6,69	97
90	32	7,14	103.6
93	34	7,61	1.4
97	36	8,1	117.6
100	38	8,62	125
104	40	9,15	132.7
108	42	9,71	1.8
111	44	10,29	149.2
115	46	10,89	157.9
118	48	11,52	167
122	50	12,17	176.5
126	52	12,84	186.2
129	54	13,54	196.4
133	56	14,27	207
136	58	15,02	217.9
140	60	15,8	229.2
144	62	16,61	241
147	64	17,45	253.2
151	66	18,32	265.8
154	68	19,22	278.8
158	70	20,15	292.3
162	72	21,12	306.3
165	74	22,12	3.8
169	76	23,15	335.7
172	78	24,22	351.2
176	80	25,32	367.2



Tightening torques

Description	Type	Torque [Nm] ± 5%
General		
Hex Head Bolt + Nut, M5		5,5
Hex Head Bolt + Nut, M6		9
Hex Head Bolt + Nut, M8		23
Hex Head Bolt + Nut, M10		47
Hex Socket Counters. Head Bolt, M6		9
Hex Socket Counters. Head Bolt, M8		23
Flare Nut ½", Brass		70
Schräder Valve, 1/8"		24
Cable Gland, M12	Lock Nut	2
	Cap Nut	1
Cable Gland, M16	Gland	5
	Cap Nut	2
Cable Gland, M20	Gland	7
	Lock Nut	4
	Cap Nut	3
Cable Gland, M25	Lock Nut	6
	Cap Nut	4
Fresh Air System		
Air Exchange Potentiometer	Slotted Cheese Head Screw, M3	1
Damper for Fresh Air	Wing Screw, M6	5
FC		
FC Mounting	Hex Lobular Socket Screw, M6	9
	Threaded bushing, sq. 8 mm	1
Compressor		
Cylinder Head	Hex Head, M10	70
Bearing Cover	Hex Socket Counters. Head Bolt, M10	54
Oil Pump Cover	Hex Head Bolt, M8	10
Sight Glass	Hex Head	60
Terminal Block	Hex Socket Counters. Head Bolt, M6	14
Pressure Transmitter, AKS	Hex Head	18
Pressure Transmitter, NSK	Hex Head	14
High Pressure Switch	Hex Head	14
Receiver		
Water Inlet Coupling, Female (brass)		70
Water Outlet Coupling, Male (brass)	Hex Head	70
Water Inlet Coupling, Female (Alu)		50
Water Outlet Coupling, Male (Alu)	Hex Head	50
Sight Glass	Hex Head	60
Melt Fuse	Hex Head	65
Valves		
Suction Gas Valve	Hex Head Bolt, M10	54
Suction Gas Valve Flange	Hex Socket Counters. Head Bolt, M10	50
Discharge- and Intermediate Valve	Hex Head Bolt, M8	30
Evacuation Valve	Hex Head	18
Unit Backside		
Evaporator Cover Plate	Hex Lobular Tapping Screw, ø4.8	5
Fresh air module		
Insect net and AirEx motor	Screw, ø4.0x16	4
AirEx potentiometer	Screw, ø4.0x25	4



Controller Unit Illustration

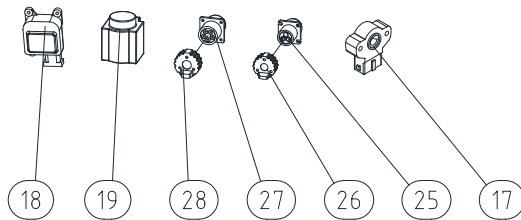
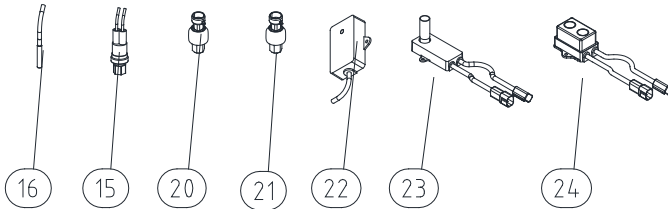
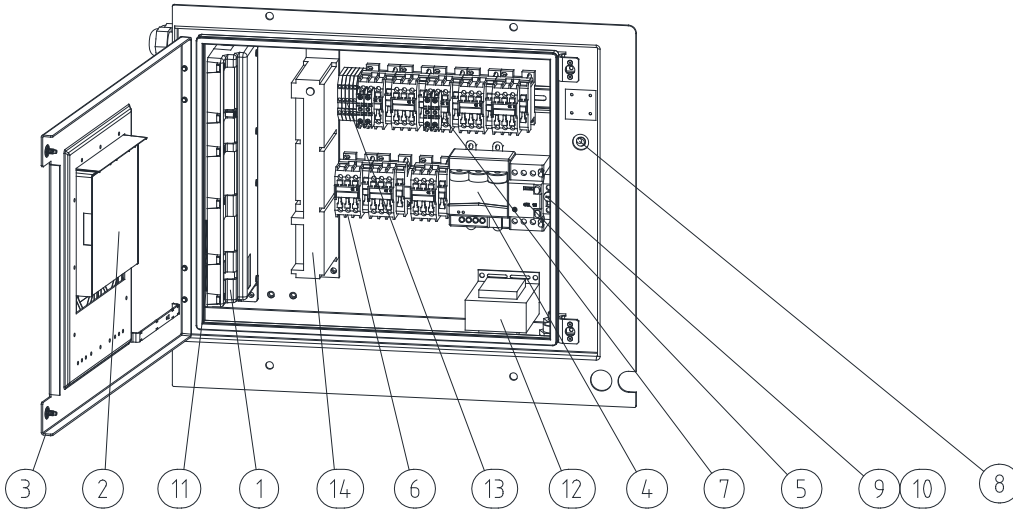

28	Retreiver Socket Cap
27	Retreiver Socket
26	USDA Socket Cap
25	USDA Socket
24	Sensor, CO2
23	Sensor, O2
22	Humidity Sensor, X-HUM digital
21	Pressure Transmitter 0-30 Bar
20	Pressure Transmitter -0.69-9.8 Bar
19	Solenoid Coil, 10W, 24VAC
18	Motor, Fresh Air
17	Air Exchange Potentiometer
16	Temperature Sensor, 1.8 m
15	High Pressure Switch
14	RMM Slave Modem, York
13	Duo Terminal
12	Transformer, 105VA
11	Battery Pack
10	Fuse, 400mA
9	Fuseholder for 0.4A Fuse
8	On/Off Switch (incl cable)
7	Auxiliary Contact
6	Contactor
5	Main Circuit Breaker, 16A
4	Power Meas Module (SPM6)
3	Controller Hatch, Mech. Part
2	User Panel (SUP6)
1	Controller Module (SMC6)
Pos.	Item Description

Setup may vary depending on model





Star Cool Unit, installation dimensions

Type: SCU

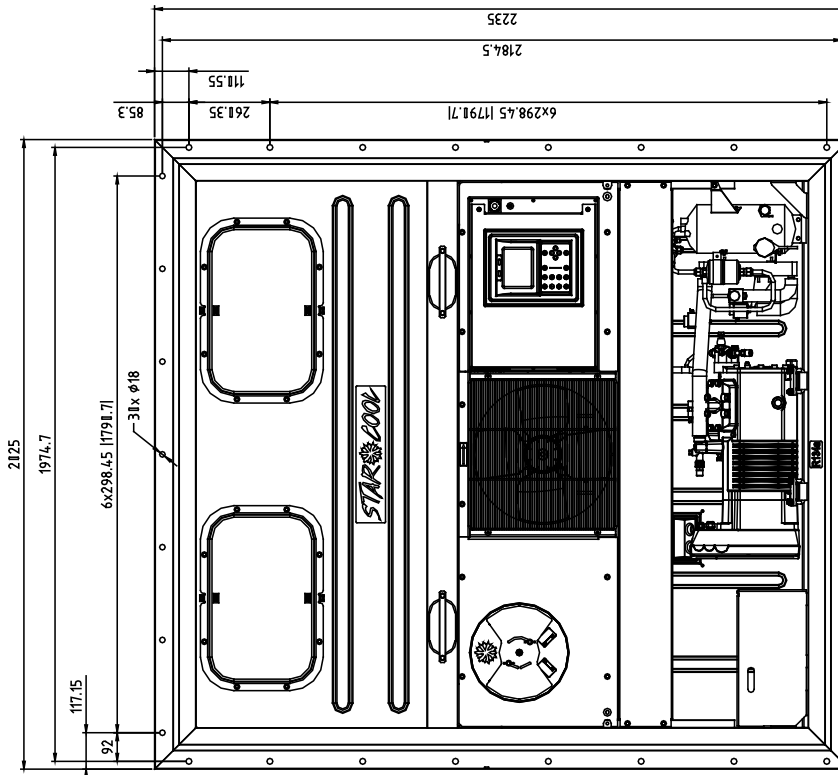
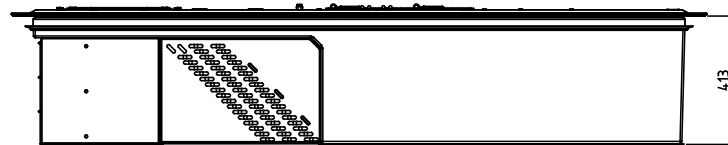
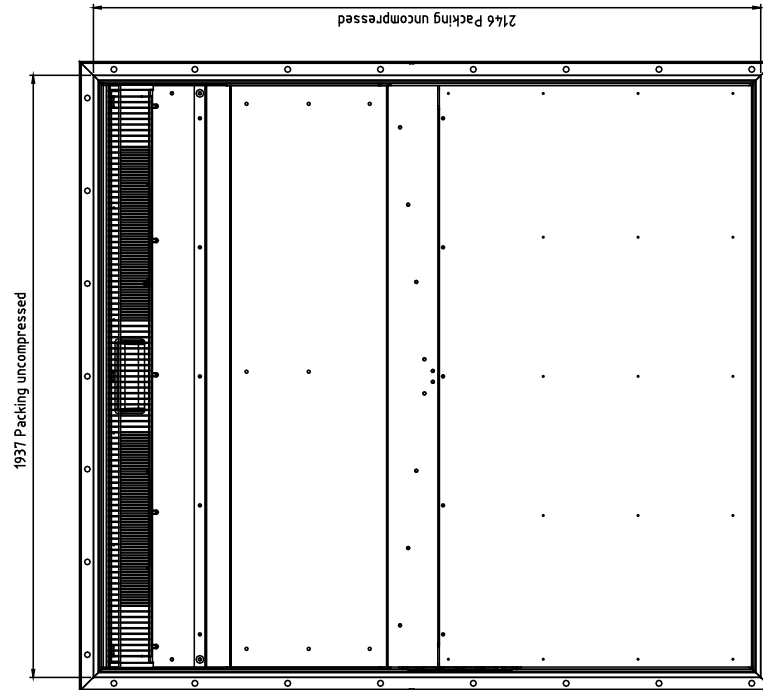



Type: SCI

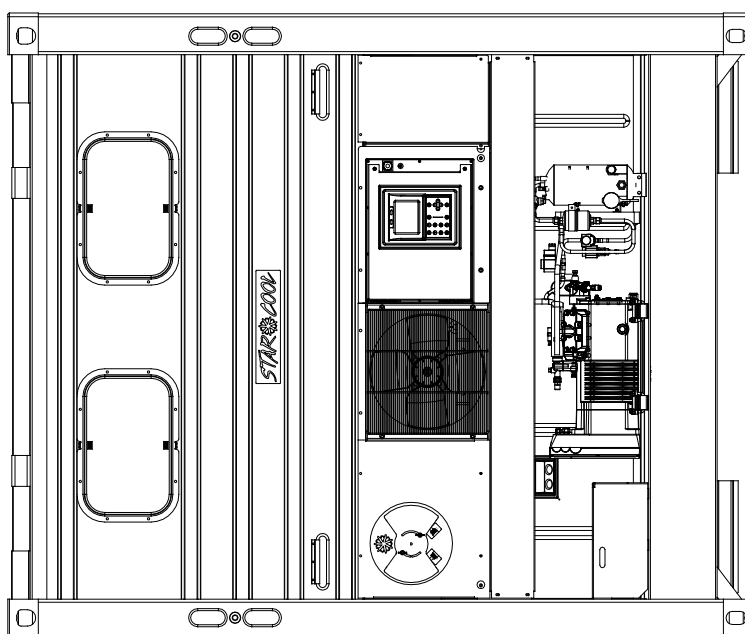
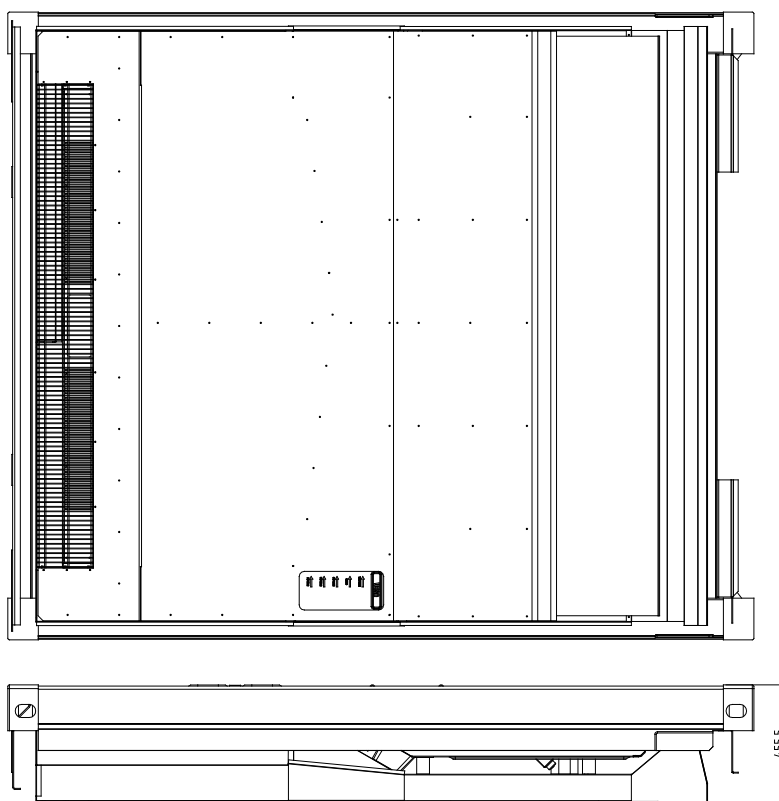



P & I diagram

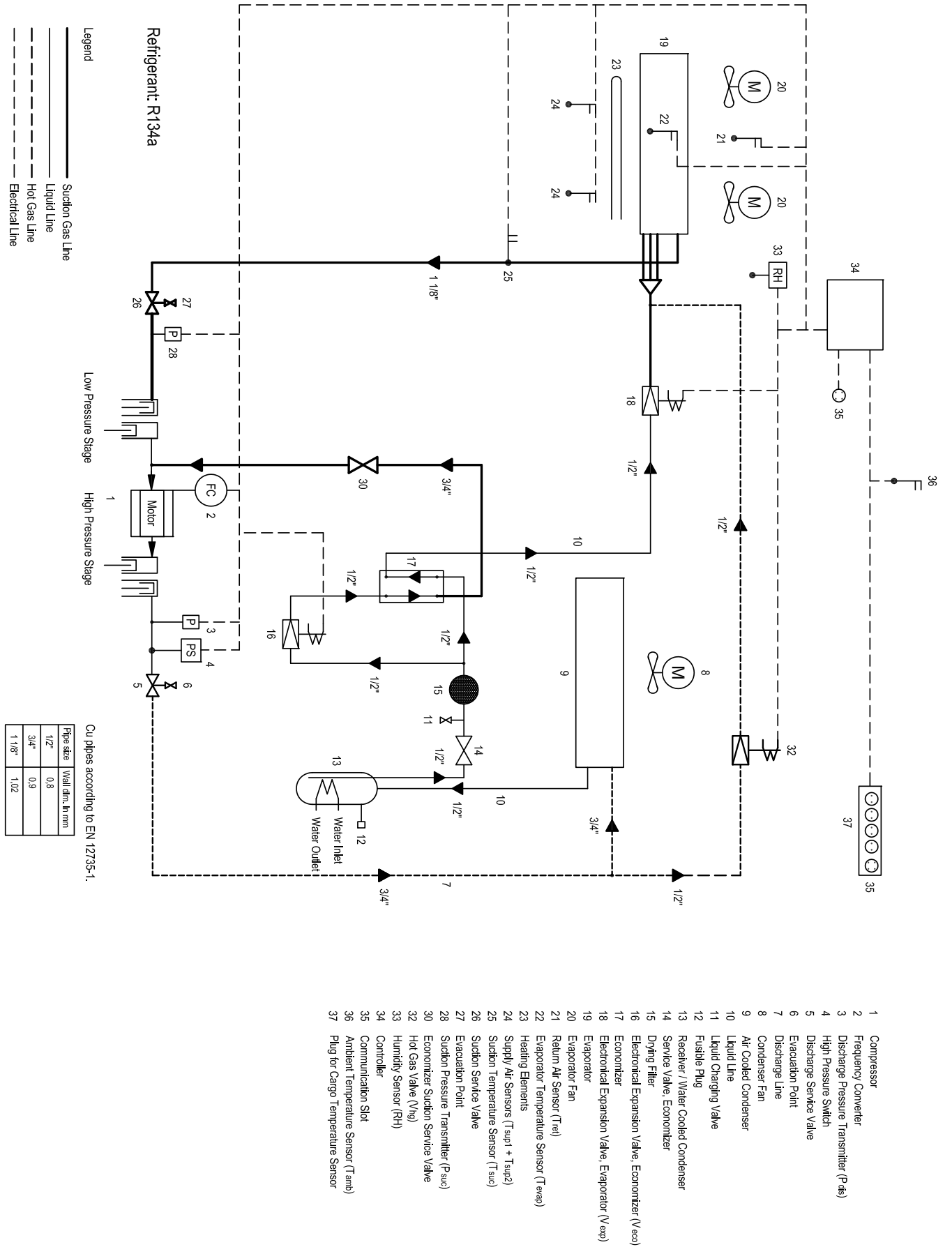

- 1 Compressor
- 2 Frequency Converter
- 3 Discharge Pressure Transmitter (P dis)
- 4 High Pressure Switch
- 5 Discharge Service Valve
- 6 Evacuation Point
- 7 Discharge Line
- 8 Condenser Fan
- 9 Air Cooled Condenser
- 10 Liquid Line
- 11 Liquid Charging Valve
- 12 Fusible Plug
- 13 Receiver / Water Cooled Condenser
- 14 Service Valve, Economizer
- 15 Drying Filter
- 16 Electronical Expansion Valve, Economizer (V eco)
- 17 Economizer
- 18 Electronical Expansion Valve, Evaporator (V exp)
- 19 Evaporator
- 20 Evaporator Fan
- 21 Return Air Sensor (T rel)
- 22 Evaporator Temperature Sensor (T exp)
- 23 Heating Elements
- 24 Supply / Air Sensors (T sup1 + T sup2)
- 25 Suction Temperature Sensor (T suc)
- 26 Suction Service Valve
- 27 Suction Service Valve
- 28 Evacuation Point
- 29 Suction Pressure Transmitter (P suc)
- 30 Economizer Suction Service Valve
- 31 Hot Gas Valve (V hg)
- 32 Humidity Sensor (RH)
- 33 Humidity Sensor (RH)
- 34 Controller
- 35 Communication Slot
- 36 Ambient Temperature Sensor (T amb)
- 37 Plug for Cargo Temperature Sensor



Overall Wiring Schematic

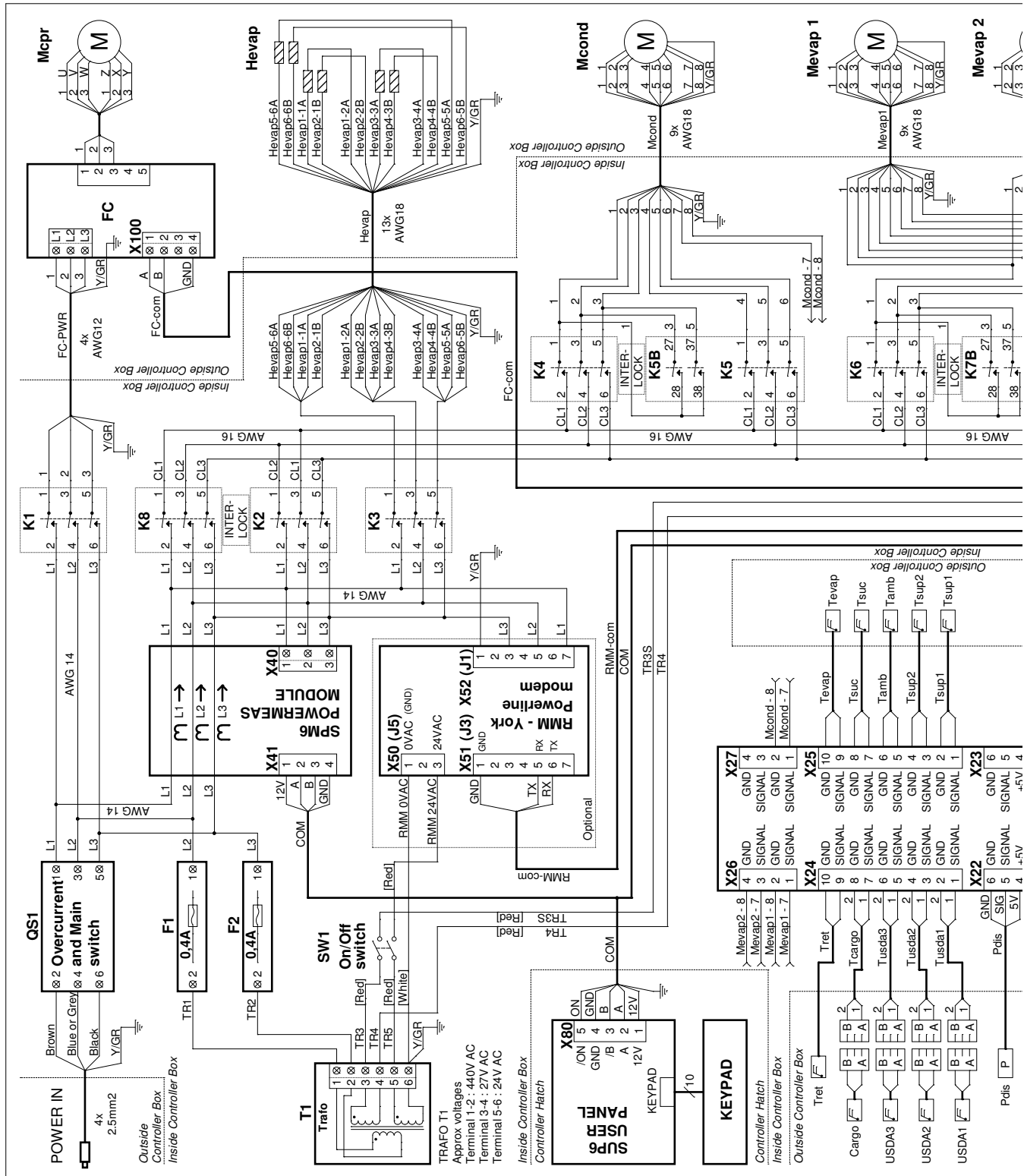

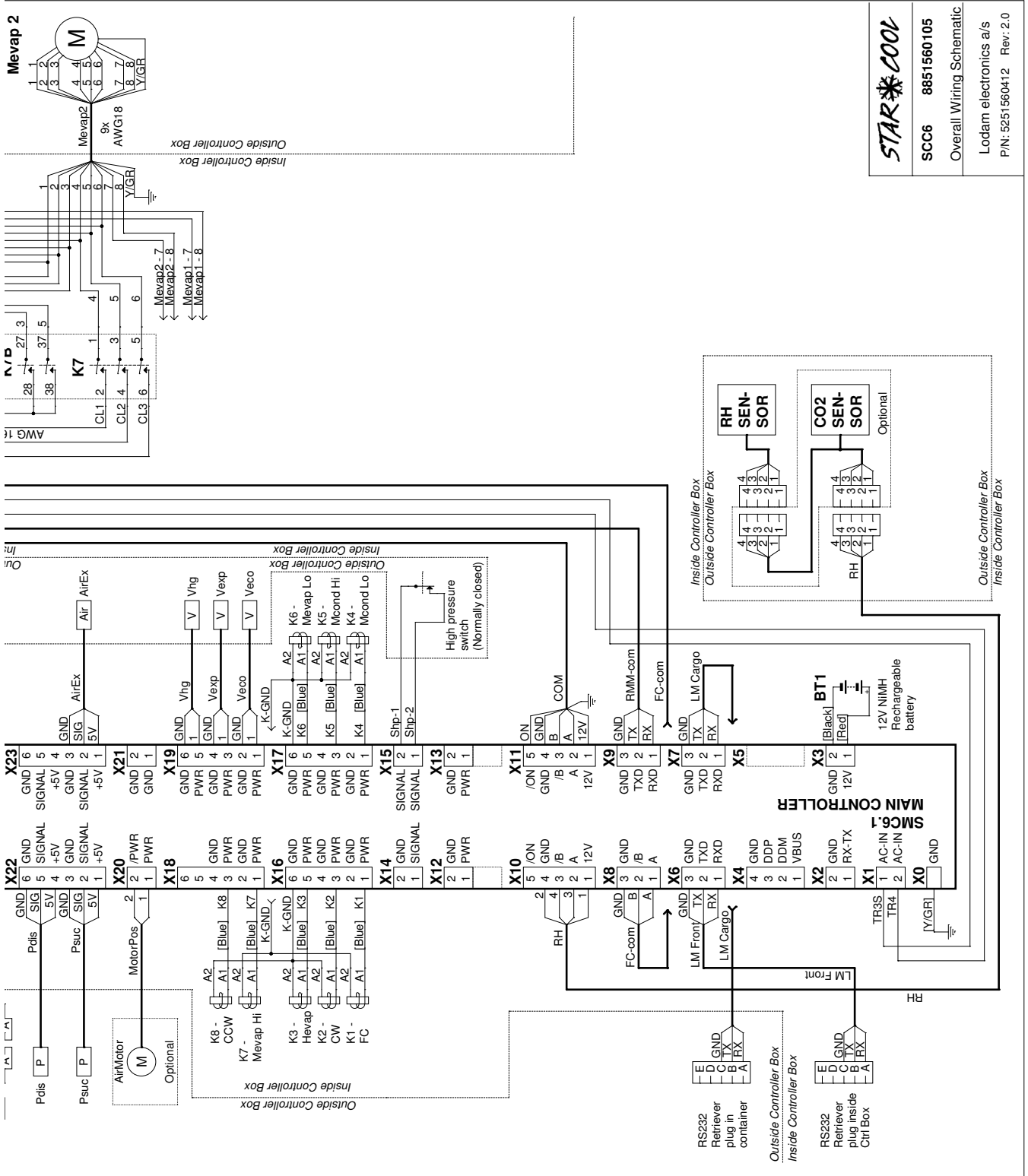

STAR COOL
SCC6 8851560105
 Overall Wiring Schematic.
 Lodam electronics a/s
 P/N: 5251560412 Rev: 2.0



Overall wiring schematics (optional)

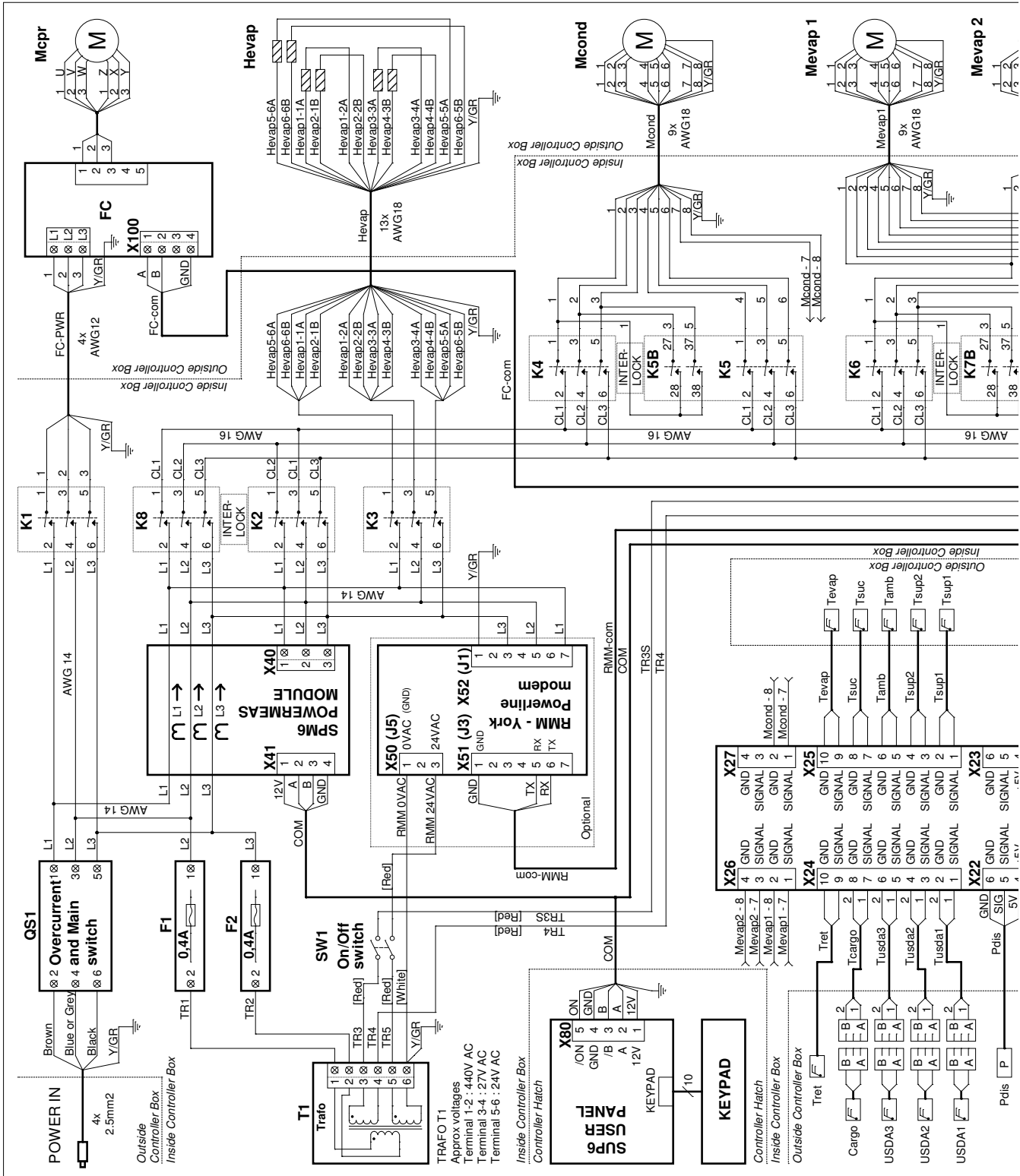

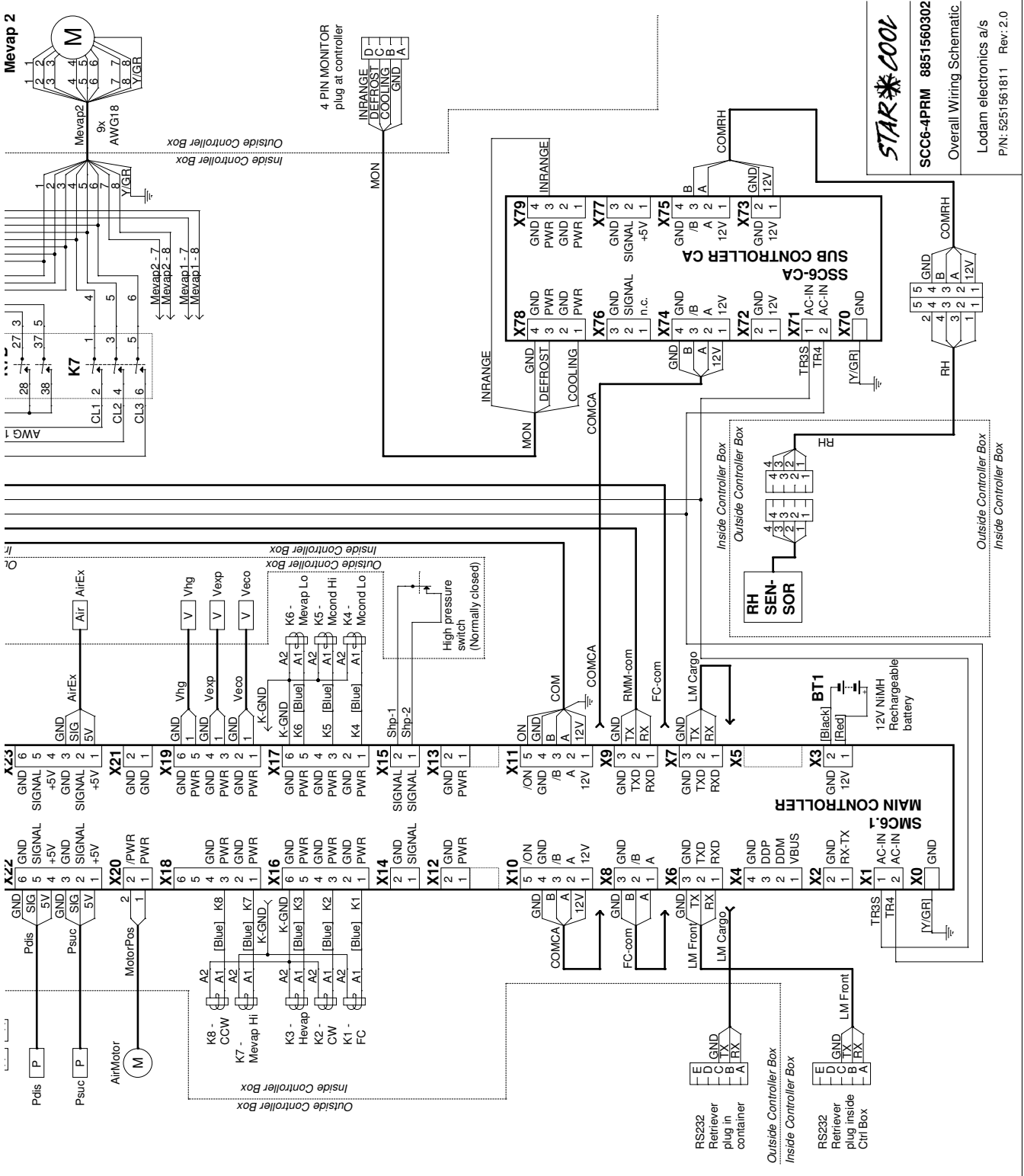

STAR*COOL
SCC6-4PRM 8851560302
Overall Wiring Schematic
Lodam electronics a/s
P/N: 5251561811 Rev: 2.0

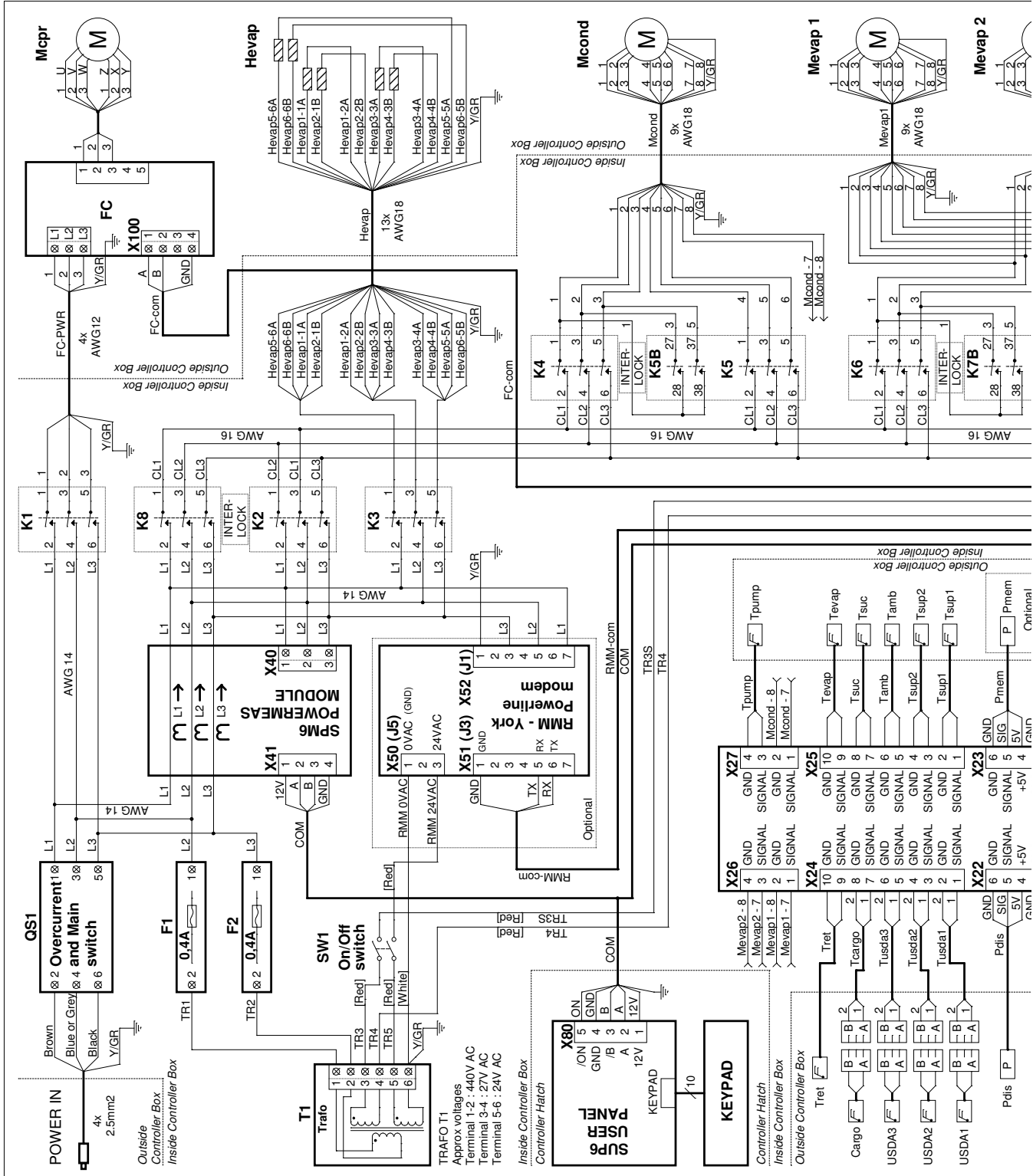

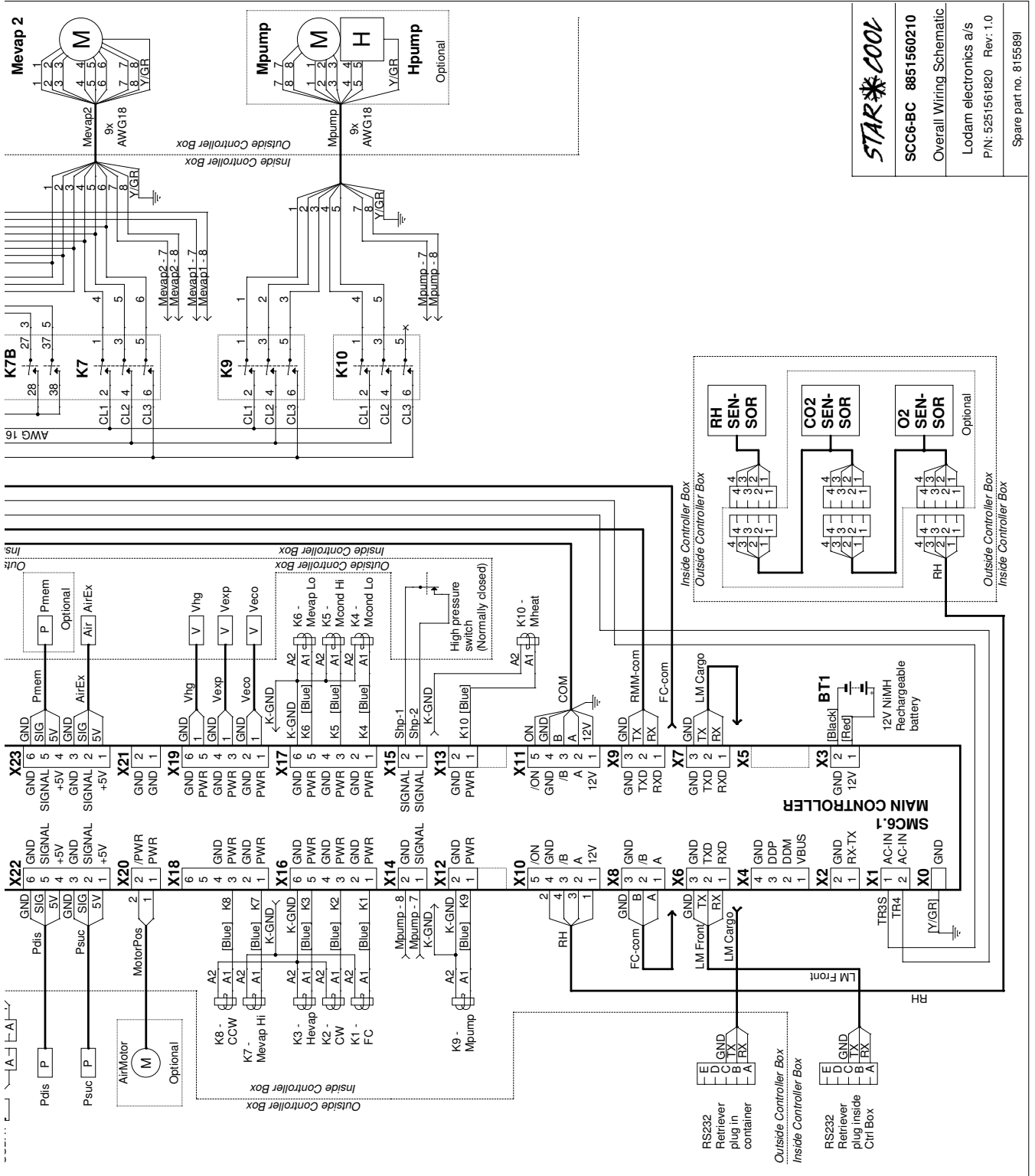



24-hour hotline support

Call us at +45 7364 3500 or send us an e-mail at service@starcool.com. Our service department is available 24 hours a day, 7 days a week - providing easy access to the answers You need.

For further troubleshooting help, go to our website URL: m.starcool.com or simply scan the QR code with Your smartphone



Bjerndrupvej 47,
6360 Tinglev, Denmark
Phone: +45 73 64 34 00
Fax.: +45 73 64 35 69
E-mail: starcool@starcool.com
www.starcool.com

STAR ❄️ **COOL**
... Cool Thinking!