

ELEPHANT GV

***instructions
for
installation***

Document number: QSM000095E

Revision: "-"

Date of first issue: 21.Jan.04

Date of latest issue: 21.Jan.04

COSTAN[®]

F3000

| | | | | | |
|--|-------------------------|------|------|------|---|
| COSTAN TECHNICAL DOCUMENTATION PRODUCT: ELEPHANT GV CHAP. No. 1 DOC. no. QSM000095E CHAPTER: CONTENTS | CHAPTER REVISION STATUS | | | | IN CONFORMITY WITH APPROVED ORIGINAL PAGE: 1/1 DATE of 1st ISSUE: 21.Jan.04 ISSUED BY MKT |
| | ORD. | DATE | ORD. | DATE | |
| | A | | D | | |
| | B | | E | | |
| | C | | F | | |

| CHAP. NO. | CHAPTER | NUMBER OF PAGES | REVISION STATUS |
|-----------|---------------------------------------|-----------------|-----------------|
| 1 | CONTENTS | 1 | "_" |
| 2 | SECTIONS | 1 | "_" |
| 3 | INSTALLATION DIAGRAMS | 3 | "_" |
| 4 | POSITION OF PROBES | 1 | "_" |
| 5 | HEAT EXTRACTION RATE DETAILS | 2 | "_" |
| 6 | ELECTRICAL DETAILS | 1 | "_" |
| 7 | THERMOSTATIC VALVE FEATURES | 2 | "_" |
| 8 | CONTROLLER ADJUSTMENT - EKC201-EKC414 | 3 | "_" |
| 9 | WIRING DIAGRAMS | 7 | "_" |
| 10 | MULTIPLEXING CABINETS | 6 | "_" |
| 11 | PLACEMENT OF DRAINS | 2 | "_" |

KEY

- "_" First issue
- A, B, C..... Chapter revision index

| ORD. | DATE | ORD. | DATE |
|------|------|------|------|
| A | | D | |
| B | | E | |
| C | | F | |

SECTIONS - ELEPHANT GV

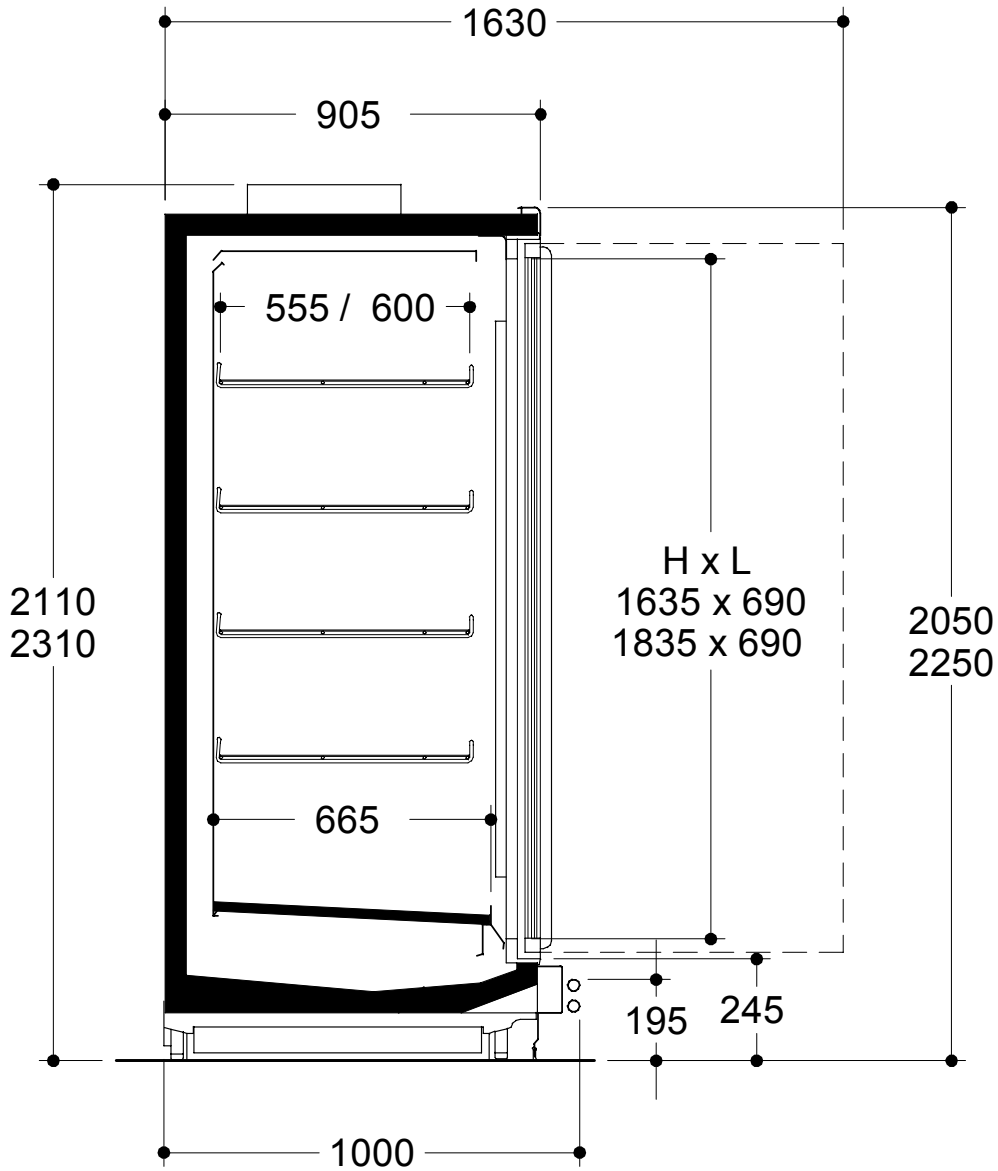

| | | | | | | |
|--|-------------------------|------|------|------|--------------------------------------|--|
| COSTAN TECHNICAL DOCUMENTATION | CHAPTER REVISION STATUS | | | | IN CONFORMITY WITH APPROVED ORIGINAL | PAGE: 1/3 |
| | ORD. | DATE | ORD. | DATE | | DATE of 1st ISSUE: 21.Jan.04 |
| PRODUCT: ELEPHANT GV CHAP. No. 3 DOC. no. QSM000095E CHAPTER: INSTALLATION DIAGRAMS | A | | D | | ISSUED BY MKT | |
| | B | | E | | | |
| | C | | F | | | |

INSTALLATION DIAGRAMS

SECTION OF WATER AND REFRIGERATING CONNECTIONS

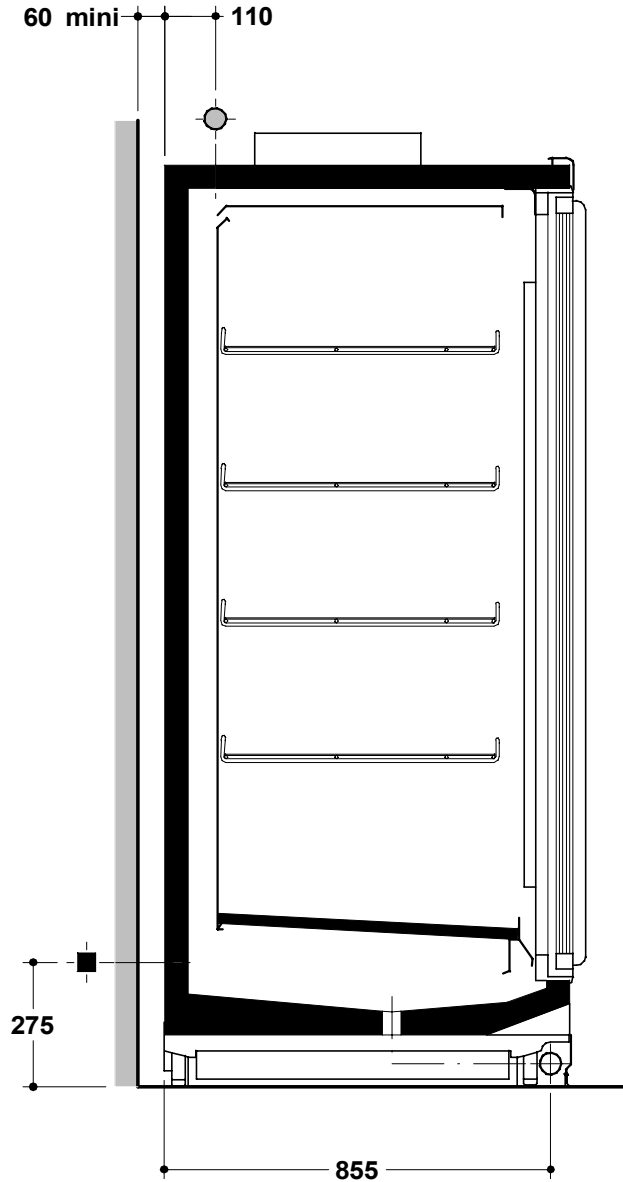

⊕ WATER OUTLET

● FREON OUTLET

| ORD. | DATE | ORD. | DATE |
|------|------|------|------|
| A | | D | |
| B | | E | |
| C | | F | |

| |
|--|
| DATE of 1st ISSUE: 21.Jan.04 |
| ISSUED BY MKT |

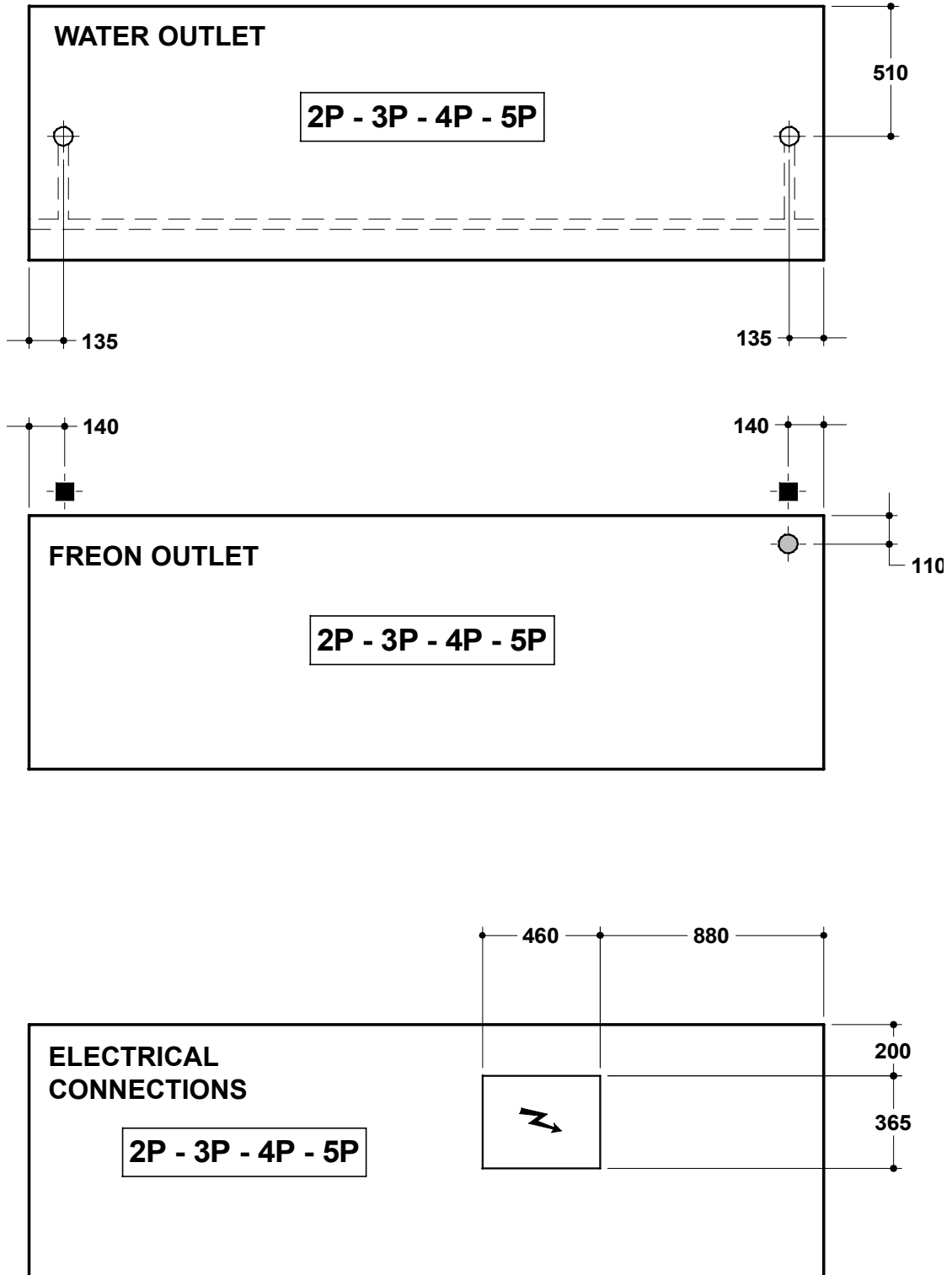

| | | | | | | |
|---------------------------------------|-------------------------|------|------|------|--------------------------------------|--|
| COSTAN TECHNICAL DOCUMENTATION | CHAPTER REVISION STATUS | | | | IN CONFORMITY WITH APPROVED ORIGINAL | PAGE: 3/3 |
| | ORD. | DATE | ORD. | DATE | | DATE of 1st ISSUE: 21.Jan.04 |
| PRODUCT: ELEPHANT GV | A | | D | | ISSUED BY MKT | |
| CHAP. No. 3 DOC. no. QSM000095E | B | | E | | | |
| CHAPTER: INSTALLATION DIAGRAMS | C | | F | | | |

POSITION OF FEET

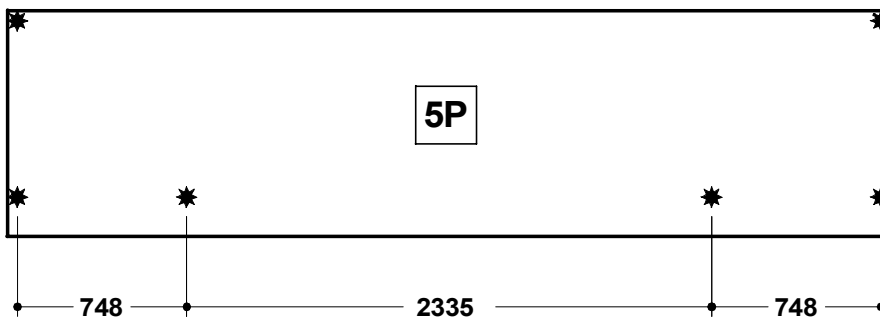
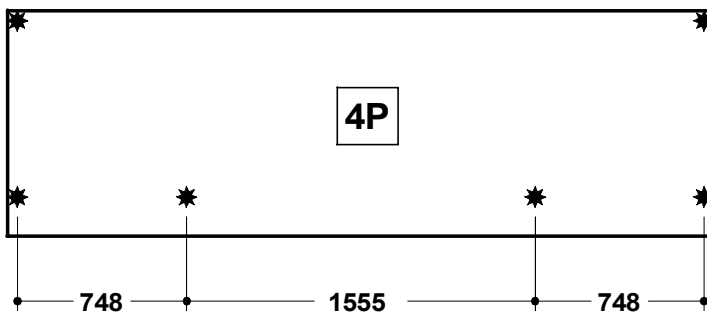
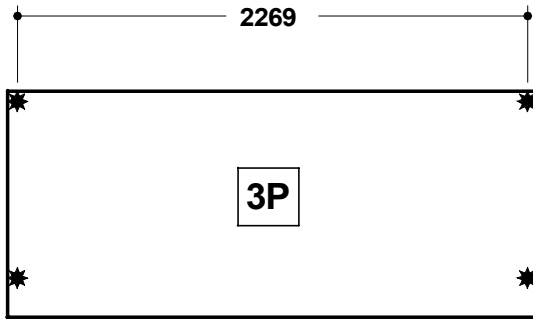
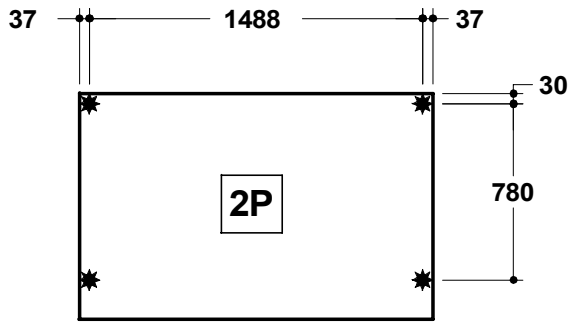

| | | | | | | |
|---|-------------------------|------|------|------|--------------------------------------|--|
| COSTAN TECHNICAL DOCUMENTATION | CHAPTER REVISION STATUS | | | | IN CONFORMITY WITH APPROVED ORIGINAL | PAGE: 1/1 |
| | ORD. | DATE | ORD. | DATE | | DATE of 1st ISSUE: 21.Jan.04 |
| PRODUCT: ELEPHANT GV | A | | D | | ISSUED BY MKT | |
| CHAP. No. 4 | B | | E | | | |
| N° DOC. QSM000095E CHAPTER: POSITION OF PROBES | C | | F | | | |

POSITION OF PROBES - CONTROLLER - THERMOSTATIC VALVE

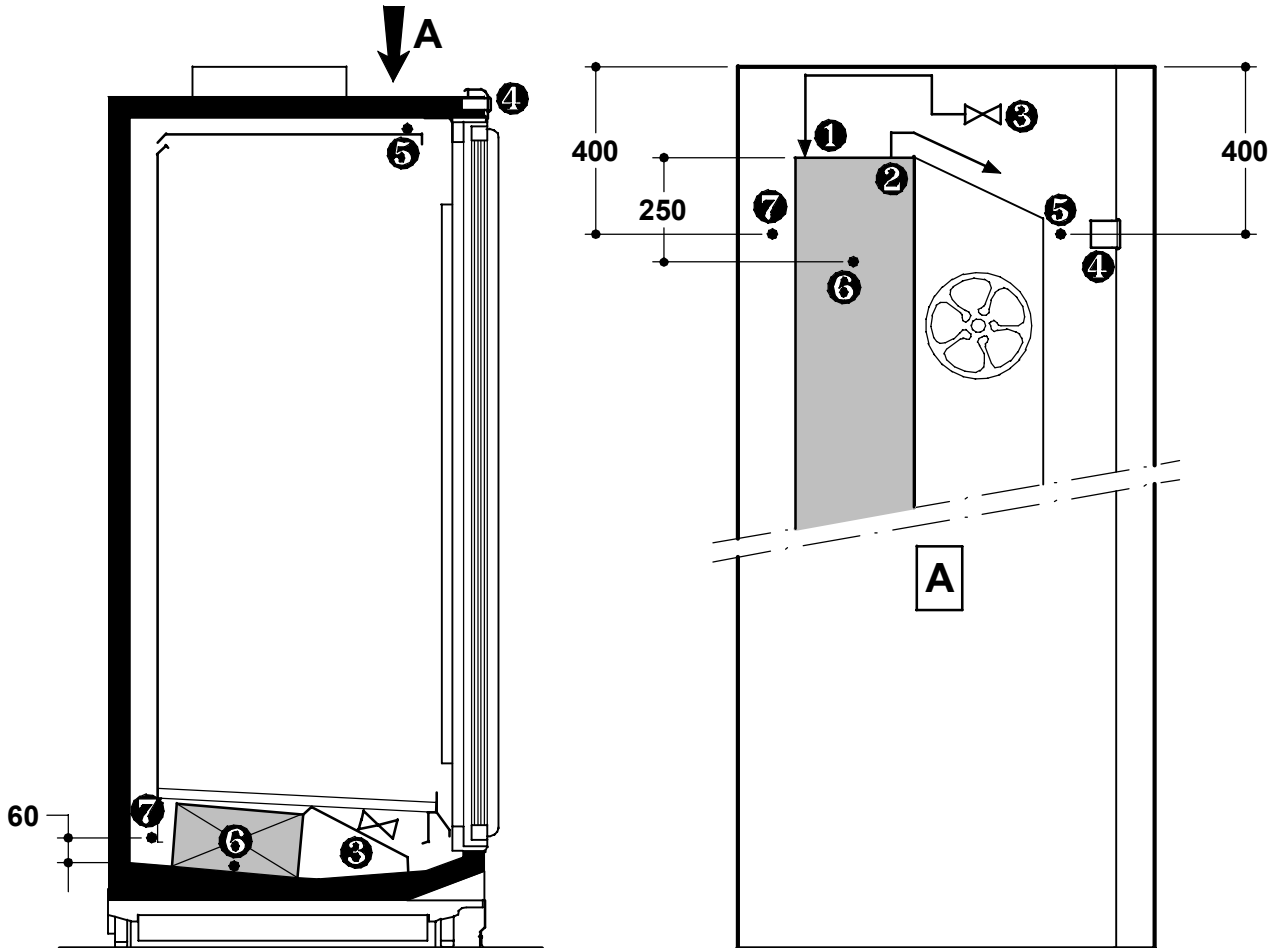

- ❶ Evaporator in-going piping
- ❷ Evaporator out-going piping
- ❸ Thermostatic valve
- ❹ Controller
- ❺ Position of air-outlet probes
- ❻ Position of defrost-end probes
- ❼ Safety thermostat

| | | | | | | |
|---|-------------------------|------|------|------|--------------------------------------|--|
| COSTAN TECHNICAL DOCUMENTATION PRODUCT: ELEPHANT GV CHAP. No. 5 DOC. no. QSM000095E CHAPTER: HEAT EXTRACTION RATE | CHAPTER REVISION STATUS | | | | IN CONFORMITY WITH APPROVED ORIGINAL | PAGE: 1/1 |
| | ORD. | DATE | ORD. | DATE | | DATE of 1st ISSUE: 21.Jan.04 |
| | A | | D | | | ISSUED BY MKT |
| | B | | E | | | |
| C | | F | | | | |

REQUIRED HEAT EXTRACTION RATE - SETTINGS

ISO 1992 / II EN 441-4 : 1994 EN 441-12 : 1997
 CLA 3 : 25° C - 60% HR

| ELEPHANT GV | C | IF | T _o °C | Φ _o (W) | | | | | |
|-------------|-----|------|-------------------|--------------------|--|------|------|------|------|
| | | | | W/m | | 2P | 3P | 4P | 5P |
| H 2200 | 3L1 | HNLS | -34 | 810 | | 1265 | 1900 | 2535 | 3165 |
| H 2000 | 3L1 | HNLS | -34 | 735 | | 1150 | 1725 | 2300 | 2875 |
| H 2200 | 3M1 | HNLS | -10 | 440 | | 690 | 1030 | 1375 | 1720 |
| H 2000 | 3M1 | HNLS | -10 | 400 | | 625 | 940 | 1250 | 1565 |

| S.L.C. | | | | | | | | | | |
|-------------|-----|------|-------------------|-------------------|---------|--------|--------------------|--------------------|-------------------|-------------------|
| ELEPHANT GV | C | IF | Ctrl | | defrost | | | | | |
| | | | C _i °C | C _o °C | Type | N/24 h | T [°] ter | t _{sbrin} | t _{sgoc} | t _{vent} |
| | | | | | | | °C | min | min | min |
| H 2200 | 3L1 | HNLS | -27 | -28 | Elet. | 1 | 15 | 30 | 10 | 5 |
| H 2000 | | | | | | | | | | |
| H 2200 | 3M1 | HNLS | -3 | -4 | Elet. | 1 | 10 | 10 | 5 | 0 |
| H 2000 | | | | | | | | | | |

t_{sbrin} : defrost duration
 t_{sgoc} : drip-off duration
 t_{vent} : fan start delay

| | | | | | | |
|--|-------------------------|------|------|------|--------------------------------------|--|
| COSTAN TECHNICAL DOCUMENTATION | CHAPTER REVISION STATUS | | | | IN CONFORMITY WITH APPROVED ORIGINAL | PAGE: 1/2 |
| | ORD. | DATE | ORD. | DATE | | DATE of 1st ISSUE: 21.Jan.04 |
| | A | | D | | | ISSUED BY MKT |
| | B | | E | | | |
| PRODUCT: ELEPHANT GV CHAP. No. 7 DOC. no. QSM000095E CHAPTER: THERMAL-EXPANSION VALVE | C | | F | | | |

FEATURES OF DANFOSS THERMOSTATIC VALVE

FEATURES OF DANFOSS THERMOSTATIC VALVE WITHOUT MOP - FITTING TO BE SOLDERED

Selection rules:

- effective heat extraction rate and evaporating temperature at lab conditions (25 °C 60% R.H. class 3);
- condensing pressure equivalent to a temperature of +35°C;
- undercooling 10 K.

| | | R404A | | | |
|------------------------|-------------|------------------------|---------------|------------------------|---------------|
| | | 3L1 / Range - B | | 3M1 / Range - N | |
| ELEPHANT GV | L | <i>TYPE</i> | <i>NOZZLE</i> | <i>TYPE</i> | <i>NOZZLE</i> |
| | | H 2000 | 2P | TS2 | 02 |
| 3P | 03 | | 01 | | |
| 4P | 03 | | 01 | | |
| 5P | TES2 | | 04 | TES2 | 01 |
| H 2200 | 2P | TS2 | 02 | TS2 | 00 |
| | 3P | | 03 | | 01 |
| | 4P | | 04 | | 01 |
| | 5P | TES2 | 04 | TES2 | 02 |

Refrigerating details refer to cabinets with thermostatic valves set to provide an undercooling value of 5K.

| | | | | | | |
|--|-------------------------|------|------|------|--------------------------------------|--|
| COSTAN TECHNICAL DOCUMENTATION | CHAPTER REVISION STATUS | | | | IN CONFORMITY WITH APPROVED ORIGINAL | PAGE: 2/2 |
| | ORD. | DATE | ORD. | DATE | | DATE of 1st ISSUE: 21.Jan.04 |
| | A | | D | | | ISSUED BY MKT |
| | B | | E | | | |
| PRODUCT: ELEPHANT GV CHAP. No. 7 N° DOC. QSM000095E CHAPTER: THERMAL-EXPANSION VALVE | C | | F | | | |

FEATURES OF DANFOSS THERMOSTATIC VALVE

Selection rules:

- effective heat extraction rate and evaporating temperature at lab conditions (25 °C 60% R.H. class 3);
- condensing pressure equivalent to a temperature of +35°C;
- undercooling 10 K.
- considering overcapacity as 25% and valve opening between 50 and 75%.

| | | | R404A | |
|--------------------|------------|---------------|---------------|---------------|
| | | | 3L1 | 3M1 |
| ELEPHANT GV | L | Type | Nozzle | Nozzle |
| H 2200 | 2 P | AKV 10 | 3 | 1 |
| | 3 P | | 4 | 2 |
| | 4 P | | 5 | 3 |
| | 5 P | | 5 | 3 |
| H 2000 | 2 P | | 3 | 1 |
| | 3 P | | 4 | 2 |
| | 4 P | | 4 | 3 |
| | 5 P | | 5 | 3 |

Refrigerating details refer to cabinets with thermostatic valves set to provide an undercooling value of 5K.

Ø DISCHARGE PIPING - SUCTION PIPING: 7

| REFRIGERANT | | | | | | | | |
|------------------------|----------------------------|--|-----------|--|-----------|--|------------------------------|--------------------------|
| ELEPHANT GV | Ø (mm) SUCTION SIDE | | | | | | Ø (mm) DISCHARGE SIDE | |
| | 2P | | 3P | | 4P | | 5P | 2P - 3P - 4P - 5P |
| H2000 H2200 | 15 | | 18 | | 18 | | 22 | 10 |

| GLYCOL COOLANT | |
|------------------------|--------------------------|
| ELEPHANT GV | Ø (mm) |
| | 2P - 3P - 4P - 5P |
| H2000 H2200 | 28 |

SETTINGS FOR CONTROLLER EKC201

| Parameter function | Parameters for Danfoss Controller | Min. value for Danfoss Controller | Max. value for Danfoss Controller | | | | | | | | | | | | | | | | | | | | | | | | | | | | | | |
|---|-----------------------------------|-----------------------------------|-----------------------------------|--|--|----|----|---|---|----|----|---|---|--|--|-----|-----|----------|----------|--|--|-----|-----|-----|-----|----|----|-----|-----|-----|-----|---|---|
| Thermostat parameters | | | | | | | | | | | | | | | | | | | | | | | | | | | | | | | | | |
| 1. Cutout T° for S4 / Sout * | OUT | -50°C | 50°C | | | | | | | | | | | | | | | | | | | | | | | | | | | | | | |
| 2. Temperature unit (°C/°F) | r05 | °C | °F | | | | | | | | | | | | | | | | | | | | | | | | | | | | | | |
| 3. S4 / Sout differential (r07 = Sout cut-in T° * - cut-out T°) | r07 | 0.1 K | 20 K | | | | | | | | | | | | | | | | | | | | | | | | | | | | | | |
| 4. S3 / Sin differential (r08 = cut-in T° * - cut-out T° Sin) | r08 | 0.1 K | 20 K | | | | | | | | | | | | | | | | | | | | | | | | | | | | | | |
| 5. Correction of signal from S4/Sout | r09 | -20.0 K | 20.0 K | | | | | | | | | | | | | | | | | | | | | | | | | | | | | | |
| 6. Correction of signal from S3/Sin | r10 | -20.0 K | 20.0 K | | | | | | | | | | | | | | | | | | | | | | | | | | | | | | |
| 7. Sin – Sout differential | r20 | 0 K | 10 K | | | | | | | | | | | | | | | | | | | | | | | | | | | | | | |
| Alarm parameters | | | | | | | | | | | | | | | | | | | | | | | | | | | | | | | | | |
| 1. Timing of temperature alarm * | A03 | 0 min | 90 min | | | | | | | | | | | | | | | | | | | | | | | | | | | | | | |
| 2. Timing of door alarm | A04 | 0 min | 90 min | | | | | | | | | | | | | | | | | | | | | | | | | | | | | | |
| 3. Upper limit exceeded S4/Sout (A05 =threshold * - cut-out T° of Sout) | A05 | 0 K | 50 K | | | | | | | | | | | | | | | | | | | | | | | | | | | | | | |
| 4. Lower limit of S4/Sout exceeded | A06 | -50 K | 0 K | | | | | | | | | | | | | | | | | | | | | | | | | | | | | | |
| 5. Upper limit of S3/Sout exceeded (A07 =threshold * - cut-out T° of Sin) | A07 | 0 K | 50 K | | | | | | | | | | | | | | | | | | | | | | | | | | | | | | |
| 6. Lower limit of S3/Sin exceeded | A08 | -50 K | 0 K | | | | | | | | | | | | | | | | | | | | | | | | | | | | | | |
| 7. S3/Sin alarm time-lag with night covers | A09 | -50 K | 50 K | | | | | | | | | | | | | | | | | | | | | | | | | | | | | | |
| VEM Parameters | | | | | | | | | | | | | | | | | | | | | | | | | | | | | | | | | |
| 1. Min. ON-time | c01 | 0 min | 15 min | | | | | | | | | | | | | | | | | | | | | | | | | | | | | | |
| 2. Gap between two defrosts | c02 | 0 min | 15 min | | | | | | | | | | | | | | | | | | | | | | | | | | | | | | |
| 3. Cut-in frequency in case of probe fault | c03 | 0% | 100% | | | | | | | | | | | | | | | | | | | | | | | | | | | | | | |
| 4. Compressor cut-out on door opening (yes/no) | c04 | No | Yes | | | | | | | | | | | | | | | | | | | | | | | | | | | | | | |
| Defrost parameters | | | | | | | | | | | | | | | | | | | | | | | | | | | | | | | | | |
| 1. Compressor On when under defrosting | d01 | No | Yes | | | | | | | | | | | | | | | | | | | | | | | | | | | | | | |
| 2. Defrost-end T° * (probe selection automatic according to d10) | d02 | 0 | 25 °C | | | | | | | | | | | | | | | | | | | | | | | | | | | | | | |
| 3. Gap between 2 defrosts (d03=24 / n° of defrosts per day) | d03 | OFF | 48 h | | | | | | | | | | | | | | | | | | | | | | | | | | | | | | |
| 4. Safety time * | d04 | 0 min | 180 min | | | | | | | | | | | | | | | | | | | | | | | | | | | | | | |
| 5. Defrost signal time-lag after start-up | d05 | 0 min | 60 min | | | | | | | | | | | | | | | | | | | | | | | | | | | | | | |
| 6. Drip off time | d06 | 0 min | 20 min | | | | | | | | | | | | | | | | | | | | | | | | | | | | | | |
| 7. Timing of fan start on defrost end | d07 | 0 min | 20 min | | | | | | | | | | | | | | | | | | | | | | | | | | | | | | |
| 8. Fan start temperature (>25C°=OFF) | d08 | -25 | 26°C | | | | | | | | | | | | | | | | | | | | | | | | | | | | | | |
| 9. Fan operation when defrosting (yes/no) | d09 | No | Yes | | | | | | | | | | | | | | | | | | | | | | | | | | | | | | |
| 10. Defrost probe | d10 | OUT | DEF | | | | | | | | | | | | | | | | | | | | | | | | | | | | | | |
| 11. Alarm delay on defrost end * | d11 | 0 min | 200 min | | | | | | | | | | | | | | | | | | | | | | | | | | | | | | |
| 12. Delay of display view after defrost end | d12 | 0 min | 30 min | | | | | | | | | | | | | | | | | | | | | | | | | | | | | | |
| 13. Defrost on start-up | d13 | No | Yes | | | | | | | | | | | | | | | | | | | | | | | | | | | | | | |
| Real time clock parameters | | | | | | | | | | | | | | | | | | | | | | | | | | | | | | | | | |
| 1. 1. Defrost start, hour | t01 | OFF | 23 h | | | | | | | | | | | | | | | | | | | | | | | | | | | | | | |
| 2. 1. Defrost start, minutes | t11 | 0 min | 59 min | | | | | | | | | | | | | | | | | | | | | | | | | | | | | | |
| 3. 2. Defrost start, hour | t02 | OFF | 23 h | | | | | | | | | | | | | | | | | | | | | | | | | | | | | | |
| 4. 2. Defrost start, minutes | t12 | 0 min | 59 min | | | | | | | | | | | | | | | | | | | | | | | | | | | | | | |
| 5. 3. Defrost start, hour | t03 | OFF | 23 h | | | | | | | | | | | | | | | | | | | | | | | | | | | | | | |
| 6. 3. Defrost start, minutes | t13 | 0 min | 59 min | | | | | | | | | | | | | | | | | | | | | | | | | | | | | | |
| 7. 4. Defrost start, hour | t04 | OFF | 23 h | | | | | | | | | | | | | | | | | | | | | | | | | | | | | | |
| 8. 4. Defrost start, minutes | t14 | 0 min | 59 min | | | | | | | | | | | | | | | | | | | | | | | | | | | | | | |
| 9. 5. Defrost start, hour | t05 | OFF | 23 h | | | | | | | | | | | | | | | | | | | | | | | | | | | | | | |
| 10. 5. Defrost start, minutes | t15 | 0 min | 59 min | | | | | | | | | | | | | | | | | | | | | | | | | | | | | | |
| 11. 6. Defrost start, hour | t06 | OFF | 23 h | | | | | | | | | | | | | | | | | | | | | | | | | | | | | | |
| 12. 6. Defrost start, minutes | t16 | 0 min | 59 min | | | | | | | | | | | | | | | | | | | | | | | | | | | | | | |
| 13. Adjustment of hour | t07 | 0 h | 23 h | | | | | | | | | | | | | | | | | | | | | | | | | | | | | | |
| 14. Adjustment of minutes | t08 | 0 min | 59 min | | | | | | | | | | | | | | | | | | | | | | | | | | | | | | |
| Ventilation parameters | | | | | | | | | | | | | | | | | | | | | | | | | | | | | | | | | |
| 1. Fans off when compressors are off | F01 | No | Yes | | | | | | | | | | | | | | | | | | | | | | | | | | | | | | |
| 2. Fan off time | F02 | 0 min | 15 min | | | | | | | | | | | | | | | | | | | | | | | | | | | | | | |
| 3. Fans off on door opening | F03 | No | Yes | | | | | | | | | | | | | | | | | | | | | | | | | | | | | | |
| Other parameters | | | | | | | | | | | | | | | | | | | | | | | | | | | | | | | | | |
| 1. Output delay on startup | o01 | 0 sec | 600 sec | | | | | | | | | | | | | | | | | | | | | | | | | | | | | | |
| 2. Digital input signals | o02 | OFF | 5 | | | | | | | | | | | | | | | | | | | | | | | | | | | | | | |
| 3. Network address (from 0 to 60) | o03 | 0 | 990 | | | | | | | | | | | | | | | | | | | | | | | | | | | | | | |
| 4. LON service connector | o04 | OFF | ON | | | | | | | | | | | | | | | | | | | | | | | | | | | | | | |
| 5. Access code | o05 | OFF | 100 | | | | | | | | | | | | | | | | | | | | | | | | | | | | | | |
| 6. Type of probe used (Pt/PTC) | o06 | Pt | PTC | | | | | | | | | | | | | | | | | | | | | | | | | | | | | | |
| 7. Max. delay after defrost synchronised with branch cabinets | o13 | OFF | 2 | | | | | | | | | | | | | | | | | | | | | | | | | | | | | | |
| 8. Selection of regulation probe | o14 | Aut | OUT | | | | | | | | | | | | | | | | | | | | | | | | | | | | | | |
| 9. Temperature display scale | o15 | No | Yes | | | | | | | | | | | | | | | | | | | | | | | | | | | | | | |
| 10. Max wait time after synchronized defrost | o16 | 1 min | 30 min | | | | | | | | | | | | | | | | | | | | | | | | | | | | | | |
| 11. Selection of display probe signal | o17 | Aut | In | | | | | | | | | | | | | | | | | | | | | | | | | | | | | | |
| 12. Manual output command | o18 | OFF | 5 | | | | | | | | | | | | | | | | | | | | | | | | | | | | | | |
| 13. Relay functions (alarm/lighting) | o36 | 1 | 2 | | | | | | | | | | | | | | | | | | | | | | | | | | | | | | |
| <p>Values to be defined at the time of installation only for Danfoss Controllers model S or S/C</p> <table border="1" style="width:100%; border-collapse: collapse;"> <tr><td>No</td><td>No</td></tr> <tr><td>0</td><td>0</td></tr> <tr><td>No</td><td>No</td></tr> <tr><td>0</td><td>0</td></tr> <tr><td colspan="2" style="text-align: center;">Values to be defined at the time of installation</td></tr> <tr><td>OFF</td><td>OFF</td></tr> <tr><td>Pt / PTC</td><td>Pt / PTC</td></tr> <tr><td colspan="2" style="text-align: center;">Values to be defined at the time of installation only for Danfoss Controller Models S or S/C</td></tr> <tr><td>OUT</td><td>OUT</td></tr> <tr><td>Yes</td><td>Yes</td></tr> <tr><td>15</td><td>15</td></tr> <tr><td>OUT</td><td>OUT</td></tr> <tr><td>OFF</td><td>OFF</td></tr> <tr><td>1</td><td>1</td></tr> </table> | | | | | | No | No | 0 | 0 | No | No | 0 | 0 | Values to be defined at the time of installation | | OFF | OFF | Pt / PTC | Pt / PTC | Values to be defined at the time of installation only for Danfoss Controller Models S or S/C | | OUT | OUT | Yes | Yes | 15 | 15 | OUT | OUT | OFF | OFF | 1 | 1 |
| No | No | | | | | | | | | | | | | | | | | | | | | | | | | | | | | | | | |
| 0 | 0 | | | | | | | | | | | | | | | | | | | | | | | | | | | | | | | | |
| No | No | | | | | | | | | | | | | | | | | | | | | | | | | | | | | | | | |
| 0 | 0 | | | | | | | | | | | | | | | | | | | | | | | | | | | | | | | | |
| Values to be defined at the time of installation | | | | | | | | | | | | | | | | | | | | | | | | | | | | | | | | | |
| OFF | OFF | | | | | | | | | | | | | | | | | | | | | | | | | | | | | | | | |
| Pt / PTC | Pt / PTC | | | | | | | | | | | | | | | | | | | | | | | | | | | | | | | | |
| Values to be defined at the time of installation only for Danfoss Controller Models S or S/C | | | | | | | | | | | | | | | | | | | | | | | | | | | | | | | | | |
| OUT | OUT | | | | | | | | | | | | | | | | | | | | | | | | | | | | | | | | |
| Yes | Yes | | | | | | | | | | | | | | | | | | | | | | | | | | | | | | | | |
| 15 | 15 | | | | | | | | | | | | | | | | | | | | | | | | | | | | | | | | |
| OUT | OUT | | | | | | | | | | | | | | | | | | | | | | | | | | | | | | | | |
| OFF | OFF | | | | | | | | | | | | | | | | | | | | | | | | | | | | | | | | |
| 1 | 1 | | | | | | | | | | | | | | | | | | | | | | | | | | | | | | | | |
| * Parameters to be adapted to the climatic class required by the foods in question | | | | | | | | | | | | | | | | | | | | | | | | | | | | | | | | | |

SETTINGS FOR CONTROLLER EKC414 - TAB.1

| Function | | | | | Parameter | MIN | MAX | EC5 T°- ELEPHANT GV | EC5 T°+ ELEPHANT GV |
|----------------------------|--|-----|---------|----------|-----------|-----|-----|--|------------------------------|
| Thermostat | | | | | | | | | |
| Set point • | | | | | | | | | |
| | | | | | | | | -28 | -4 |
| 1 | Differential | r01 | 0.1K | 10.0K | | | | 1 | 1 |
| 2 | Max. limitation of thermostat set-point | r02 | -49°C | 50°C | | | | -25 | 0 |
| 3 | Min. limitation of thermostat set-point | r03 | -50°C | 49°C | | | | -35 | -10 |
| 4 | Temperature unit | r05 | °C | °F | | | | °C | °C |
| 5 | Correction of the signal from S4 (Sout) | r09 | -10.0K | 10.0K | | | | 0 | 0 |
| 6 | Correction of the signal from S3 (Sin) | r10 | -10.0K | 10.0K | | | | 0 | 0 |
| 7 | Main switch for the controller | r12 | OFF | ON | | | | ON | ON |
| 8 | Night Offset | r13 | -20.0K | 20.0K | | | | 0 | 0 |
| 9 | Thermostat mode 1 = ON/OFF, 2 = Modulating | r14 | 1 | 2 | | | | 1 | 1 |
| 10 | Weighting of sensors for thermostat 100%=S4 (Sout), 0%=S3 (Sin) | r15 | 0% | 100% | | | | 100 | 100 |
| 11 | Interval between defrost starts | r16 | 0 h | 10 h | | | | 0 | 0 |
| 12 | Defrost duration | r17 | 0 min | 10 min | | | | 0 | 0 |
| Alarms | | | | | | | | | |
| 1 | Delay for temperature alarm | A03 | 0 min | 120 min | | | | 10 | 10 |
| 2 | Delay for door alarm | A04 | 0 min | 90 min | | | | 90 | 90 |
| 3 | Delay for pulldown | A12 | 0 min | 240 min | | | | 60 | 60 |
| 4 | High temperature limit • | A13 | -50°C | 50°C | | | | -15 | 5 |
| 5 | Low temperature limit | A14 | -50°C | 50°C | | | | -50 | -50 |
| Compressor function | | | | | | | | | |
| 1 | Min. ON-time | c01 | 0 min. | 50 min. | | | | 0 | 0 |
| 2 | Min. OFF-time | c02 | 0 min. | 50 min. | | | | 0 | 0 |
| Defrost | | | | | | | | | |
| 1 | Defrost stop temperature | d02 | 0 | 25°C | | | | 15 | 10 |
| 2 | Interval between defrost starts • | d03 | OFF | 48 h | | | | 24 | 24 |
| 3 | Max. defrost duration | d04 | 0 | 180 min | | | | 45 | 20 |
| 4 | Defrost delay after power up | d05 | 0 | 240 min | | | | 0 | 0 |
| 5 | Drip-off time | d06 | 0 | 60 min | | | | 10 | 5 |
| 6 | Delay for fan start after defrost | d07 | 0 | 60 min | | | | 5 | 0 |
| 7 | Fan start temperature | d08 | -15 | 0°C | | | | 0 | 0 |
| 8 | Fans on during defrost (yes/no) | d09 | No | yes | | | | No | No |
| 9 | Defrost sensor 0=S4 (Sout), 1=S5 (Sdef), 2=none i.e. time-controlled stop | d10 | 0 | 2 | | | | 1 | 1 |
| 10 | Defrost start on power up | d13 | No | yes | | | | No | No |
| Realtime clock | | | | | | | | | |
| 1 | 1. Defrost start. Hours | t01 | OFF | 23hours | | | | Values for Controller Danfoss C or S/C to be defined at the time of installation | |
| 2 | 1. Defrost start. Minutes | t11 | 0 | 59 min | | | | | |
| 3 | 2. Defrost start. Hours | t02 | OFF | 23hours | | | | | |
| 4 | 2. Defrost start. Minutes | t12 | 0 | 59 min | | | | | |
| 5 | 3. Defrost start. Hours | t03 | OFF | 23hours | | | | | |
| 6 | 3. Defrost start. Minutes | t13 | 0 | 59 min | | | | | |
| 7 | 4. Defrost start. Hours | t04 | OFF | 23hours | | | | | |
| 8 | 4. Defrost start. Minutes | t14 | 0 | 59 min | | | | | |
| 9 | 5. Defrost start. Hours | t05 | OFF | 23hours | | | | | |
| 10 | 5. Defrost start. Minutes | t15 | 0 | 59 min | | | | | |
| 11 | 6. Defrost start. Hours | t06 | OFF | 23hours | | | | | |
| 12 | 6. Defrost start. Minutes | t16 | 0 | 59 min | | | | | |
| 13 | Setting of Hours | t07 | 0 | 23hours | | | | | |
| 14 | Setting of minutes | t08 | 0 | 59 min | | | | | |
| 15 | Start time of day operation (0=constant day) | t17 | 0 | 23 | | | | | |
| 16 | Start time night operation (0=constant day) | t18 | 0 | 23 | | | | | |
| Injection control | | | | | | | | | |
| 1 | Max. limit of superheat reference | n09 | 3.0 K | 15.0 K | | | | 6 | 6 |
| 2 | Min. limit of superheat reference | n10 | 3.0 K | 10.0 K | | | | 4 | 4 |
| 3 | MOP Temperature | n11 | -50.0°C | 15°C/off | | | | OFF | OFF |
| 5 | AKV pulsing period | n13 | 3 sec. | 6 sec. | | | | 6 | 6 |
| 10 | Stability | n18 | 0 | 10 | | | | 4 | 4 |
| 11 | Forced closing ON =AkV closed | n36 | OFF | ON | | | | OFF | OFF |

| | | | | | | |
|---|-------------------------|------|------|------|--------------------------------------|---|
| COSTAN TECHNICAL DOCUMENTATION PRODUCT: ELEPHANT GV CHAP. no. 8 DOC. no. QSM000095E CHAPTER: CONTROLLER ADJUSTMENT | CHAPTER REVISION STATUS | | | | IN CONFORMITY WITH APPROVED ORIGINAL | PAGE: 3/3 DATE of 1st ISSUE: 21.Jan.04 ISSUED BY MKT |
| | ORD. | DATE | ORD. | DATE | | |
| | A | | D | | | |
| | B | | E | | | |
| | | C | | F | | |

SETTINGS FOR CONTROLLER EKC414 - TAB.2

| | | | | | EC5 T ⁻ ELEPHANT GV | EC5 T ⁺ ELEPHANT GV |
|--|--|-----------|--------|----------|--|---|
| Function | | Parameter | MIN | MAX | | |
| Fan control | | | | | | |
| 1 | Fan stop on compressor cut out | F01 | No | yes | No | No |
| 2 | Fan stop delay when compressor cuts out | F02 | 0 min | 30 min | 0 | 0 |
| 3 | Temperature limit for fan stopped via S5 (Sdef) value | F04 | -50.0 | 50.0/off | OFF | OFF |
| Miscellaneous | | | | | | |
| 1 | Delay of output signal after start up | o01 | 0 sec | 600 sec | 0 | 0 |
| 2 | DI control OFF=not used, 1=door alarm, 2=Defrost start, 3=Night, 4=Main switch, 5=Slave defrost | o02 | OFF | 5 | Values to be defined at the time of installation | |
| 3 | Network address | o03 | 0 | 990 | | |
| 4 | ON/OFF Switch (service-pin message) | o04 | OFF | ON | | |
| 5 | Access code | o05 | OFF | 100 | | |
| 6 | Used sensor type (Pt/PTC) | o06 | Pt | PTC | Pt/PTC | Pt/PTC |
| 7 | Language 0=English, 1=German, 2=French, 3=Danish, 4=Spanish, 5=Italian | o11 | 0 | 5 | 0 | 0 |
| 7 | Voltage selection 50/60 Hz | o12 | 50 | 60 | 50 | 50 |
| 8 | DO output controls OFF=not used, 1=Def. Master, 2=Def. Slave | o13 | 0 | 2 | Values for controller Danfoss C or S/C to be defined at the time of installation | |
| 10 | Display step no=0.1, yes =0.5 | o15 | No | yes | yes | yes |
| 11 | Max. standby on defrost end | o16 | 1 min | 30 min | 15 | 30 |
| 12 | Display S4 % (Sout) 0%=S3 (Sin) 100%=S4 (Sout) | o17 | 0% | 100% | 100 | 100 |
| 13 | Manual control of output via EKC | o18 | OFF | 7 | OFF | OFF |
| 14 | Pressare min. value | o20 | -1 bar | 5 bar | -1 | -1 |
| 15 | Pressure max. value | o21 | 6 bar | 36 bar | 12 | 12 |
| 16 | ON input control | o29 | 1 | 4 | 1 | 1 |
| 17 | Refrigerant selection ONLY for the use of R404A . WARNING: Wrong selection of refrigerant may cause damage to the compressor | o30 | 0 | 30 | 19 | 19 |
| Service | | | | | | |
| 1 | u09 ... u26 | | | | read only | read only |
| <ul style="list-style-type: none"> Parameter to be adapted to food temperature class or ambient conditions. | | | | | | |

| | | | | | | |
|---|-------------------------|------|------|------|--|--|
| COSTAN TECHNICAL DOCUMENTATION PRODUCT: ELEPHANT GV CHAP. No. 9 N° DOC. QSM000095E CHAPTER: WIRING DIAGRAMS | CHAPTER REVISION STATUS | | | | IN CONFORMITY WITH APPROVED ORIGINAL | PAGES: 1/7 |
| | ORD. | DATE | ORD. | DATE | | DATE of 1st ISSUE: 21.Jan.04 |
| | A | | D | | | ISSUED BY MKT |
| | B | | E | | | |
| C | | F | | | | |

WIRING DIAGRAMS

| ORD. | DATE | ORD. | DATE |
|------|------|------|------|
| A | | D | |
| B | | E | |
| C | | F | |

FTB WIRING DIAGRAM
(FINAL TERMINAL STRIP)

★ According to equipment

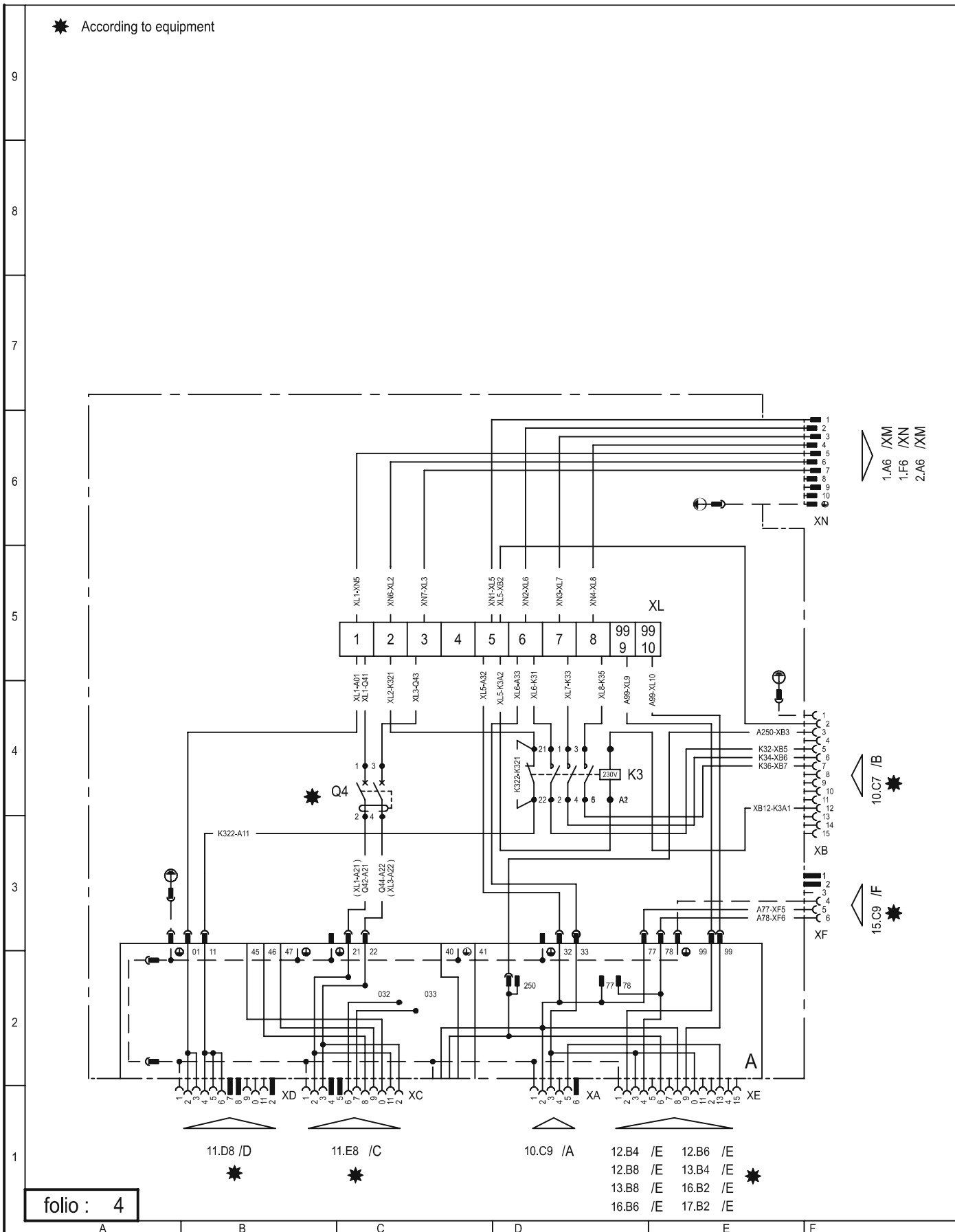

1.A6 /XM
1.F6 /XN
2.A6 /XM

10.C7 /B ★

15.C9 /F ★

11.D8 /D ★ 11.E8 /C ★ 10.C9 /A 12.B4 /E 12.B6 /E
 12.B8 /E 13.B4 /E ★ 13.B8 /E 16.B2 /E
 16.B6 /E 17.B2 /E

folio : 4

| ORD. | DATE | ORD. | DATE |
|------|------|------|------|
| A | | D | |
| B | | E | |
| C | | F | |

| |
|--|
| DATE of 1st ISSUE: 21.Jan.04 |
| ISSUED BY MKT |

WIRING DIAGRAM (FANS/DEFROST/SAFETY THERMOSTAT)

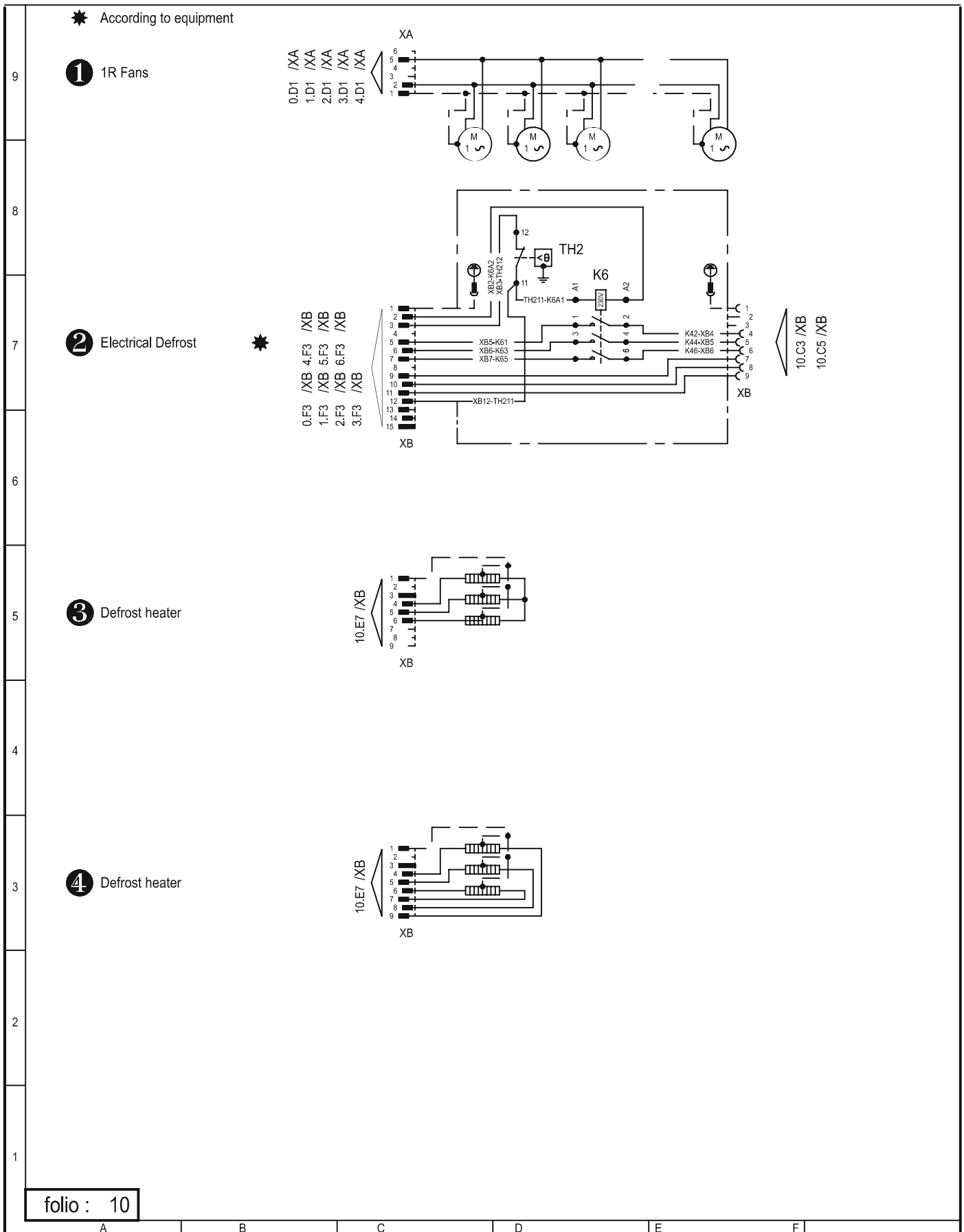

| ORD. | DATE | ORD. | DATE |
|------|------|------|------|
| A | | D | |
| B | | E | |
| C | | F | |

WIRING DIAGRAM (EKC201)

★ According to equipment

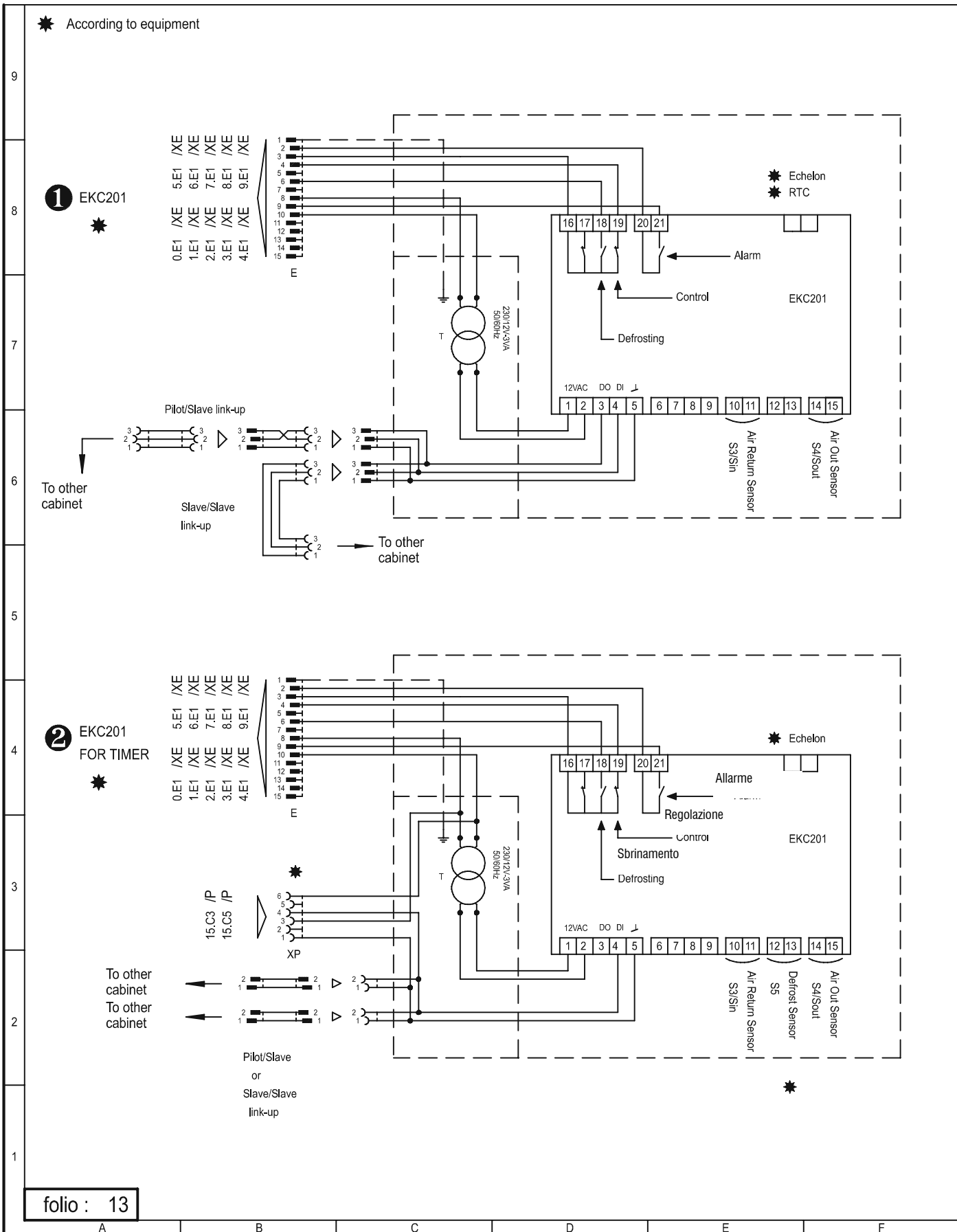

WIRING DIAGRAM (EKC414A)

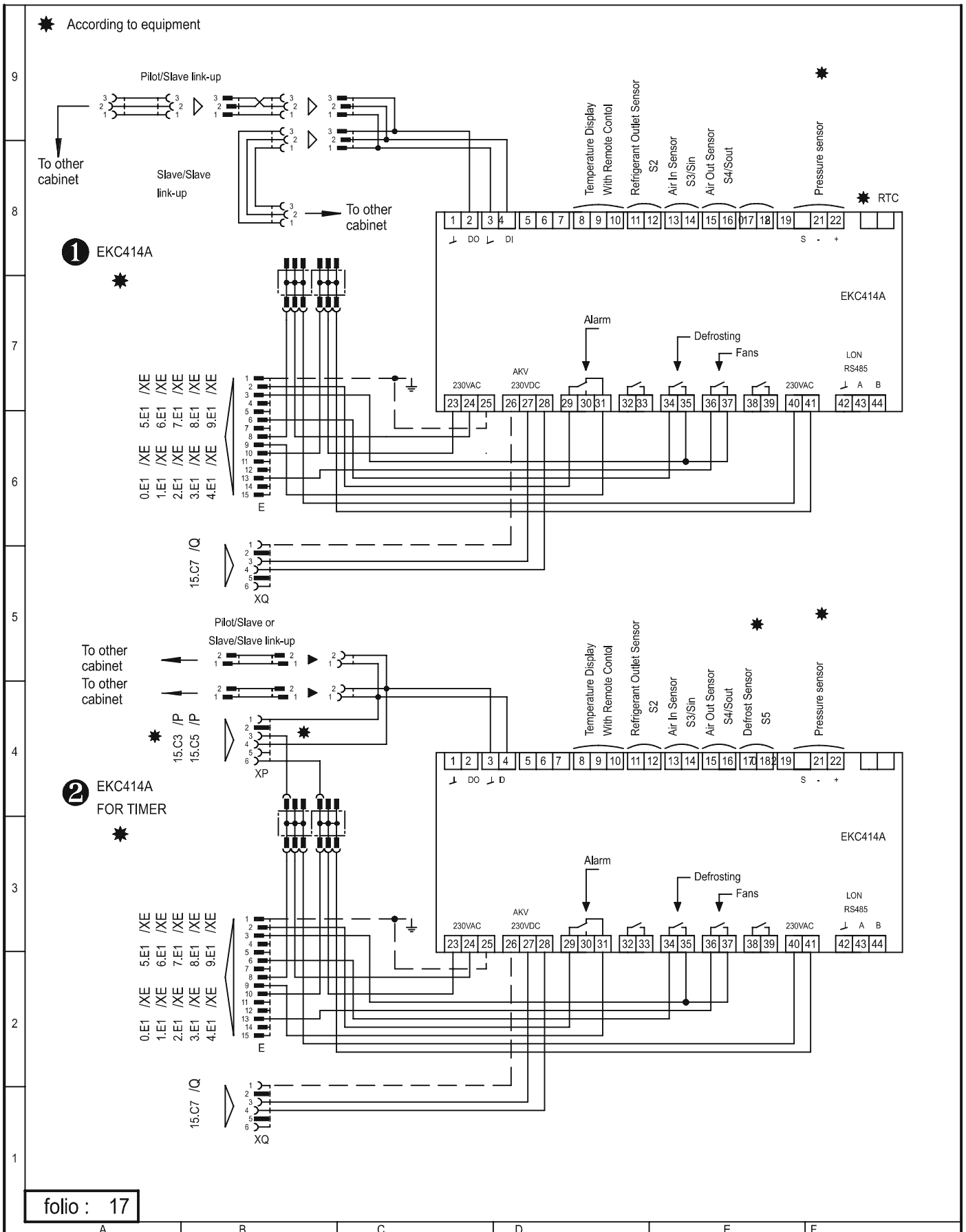

| ORD. | DATE | ORD. | DATE |
|------|------|------|------|
| A | | D | |
| B | | E | |
| C | | F | |

| |
|--|
| DATE of 1st ISSUE: 21.Jan.04 |
| ISSUED BY MKT |

WIRING DIAGRAM (EMV AC-DC/DEF.RELAY/TIMER)

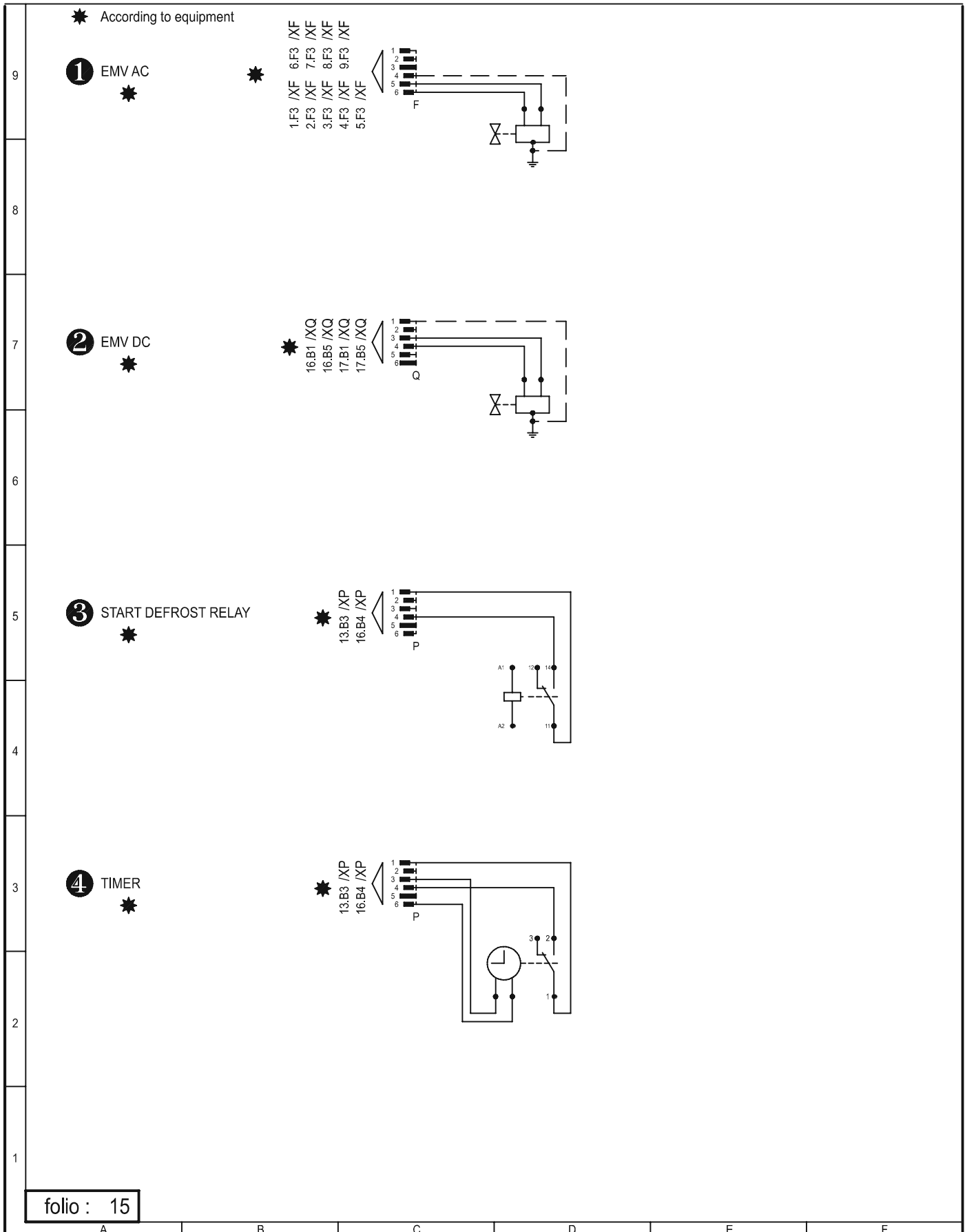

| | | | | | | |
|---------------------------------------|-------------------------|------|------|------|--------------------------------------|--|
| COSTAN TECHNICAL DOCUMENTATION | CHAPTER REVISION STATUS | | | | IN CONFORMITY WITH APPROVED ORIGINAL | PAGE: 1/6 |
| | ORD. | DATE | ORD. | DATE | | DATE of 1st ISSUE: 21.Jan.04 |
| PRODUCT: ELEPHANT GV | A | | D | | ISSUED BY MKT | |
| CHAP. no. 10 DOC. no. QSM000095E | B | | E | | | |
| CHAPTER: MULTIPLEXING CABINETS | C | | F | | | |

MULTIPLEXING CABINETS

UNPACK THE CABINETS

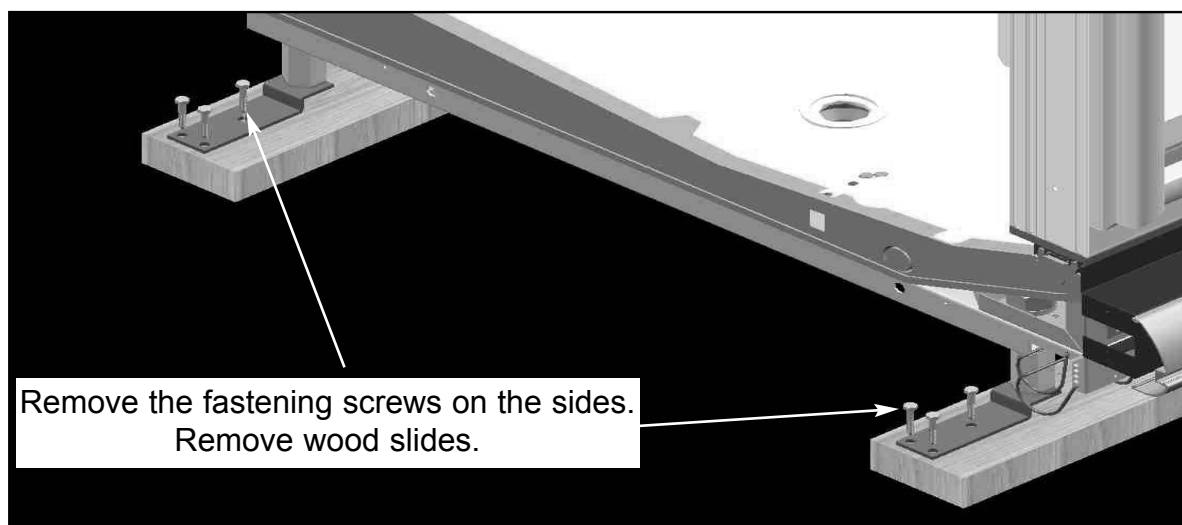
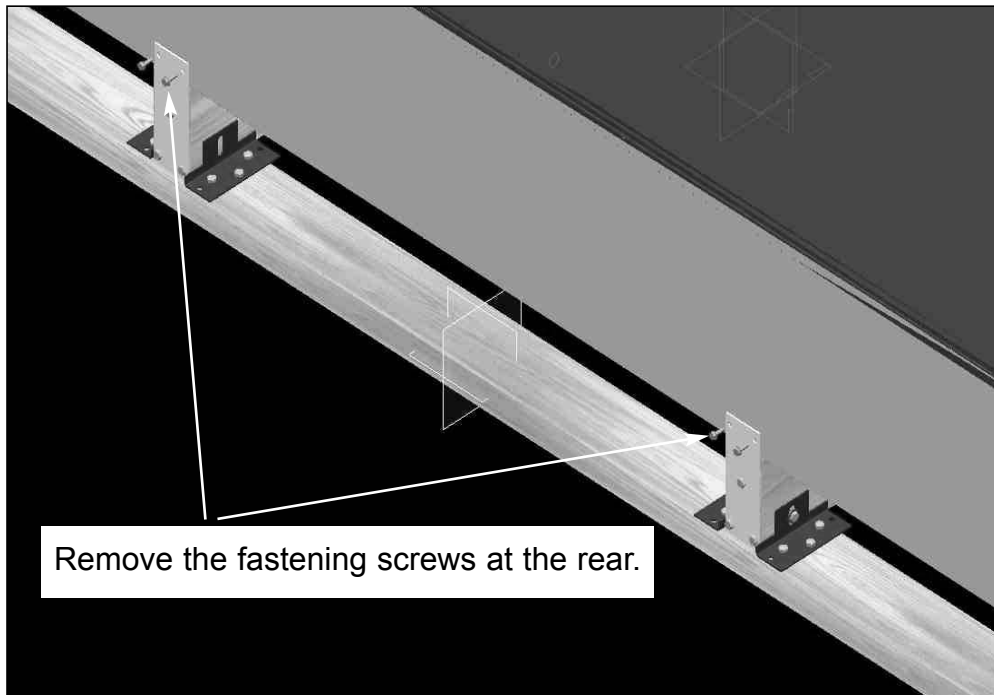

| ORD. | DATE | ORD. | DATE |
|------|------|------|------|
| A | | D | |
| B | | E | |
| C | | F | |

LEVEL THE CABINET

Remove bottom plates.

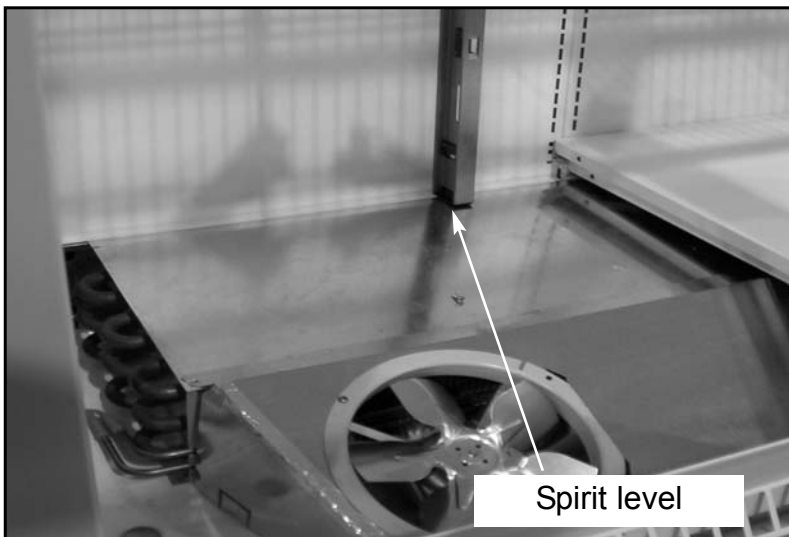
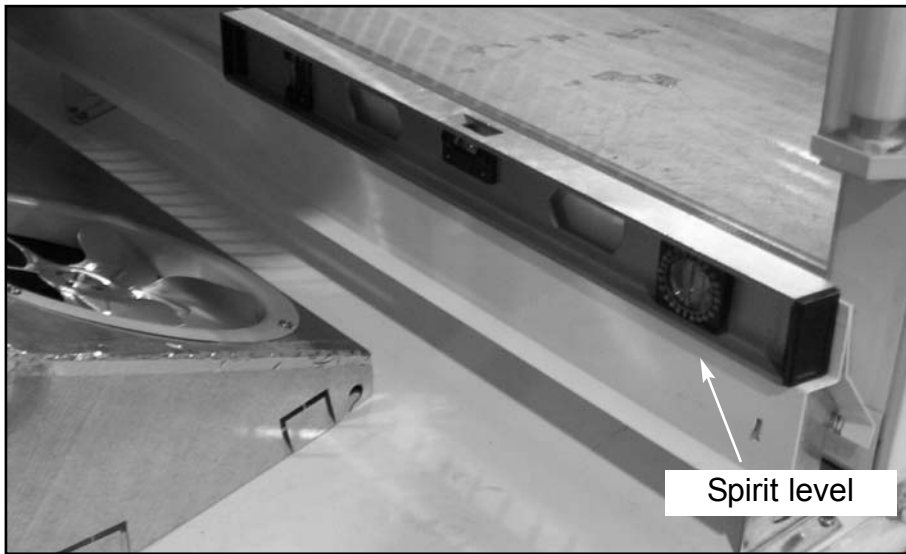
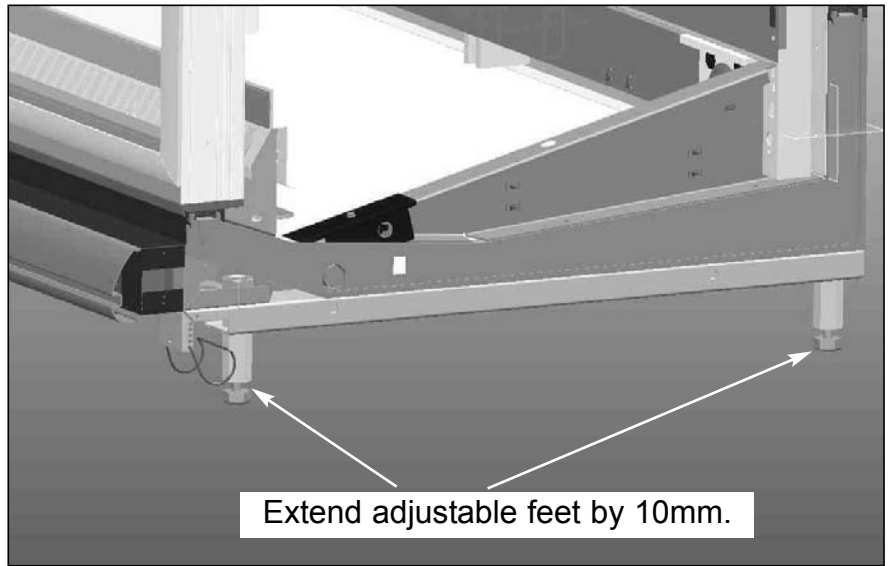

Raise fore feet further 5mm so that the cabinet slants backwards.

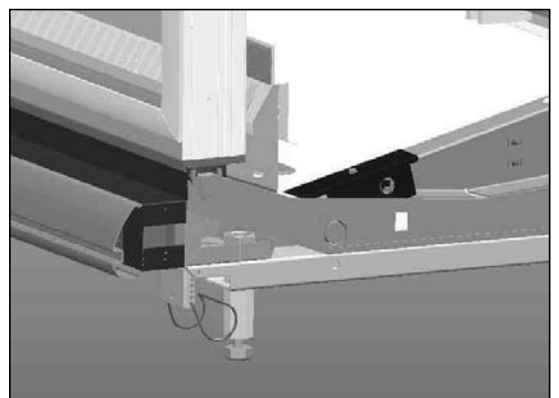

| | | | | | | |
|---------------------------------------|-------------------------|------|------|------|--------------------------------------|--|
| COSTAN TECHNICAL DOCUMENTATION | CHAPTER REVISION STATUS | | | | IN CONFORMITY WITH APPROVED ORIGINAL | PAGE: 3/6 |
| | ORD. | DATE | ORD. | DATE | | DATE of 1st ISSUE: 21.Jan.04 |
| PRODUCT: ELEPHANT GV | A | | D | | ISSUED BY MKT | |
| CHAP. no. 10 DOC. no. QSM000095E | B | | E | | | |
| CHAPTER: MULTIPLEXING CABINETS | C | | F | | | |

APPLY SPONGE RUBBER

Apply sponge rubber onto one of the cabinets to be coupled as shown in the drawing.

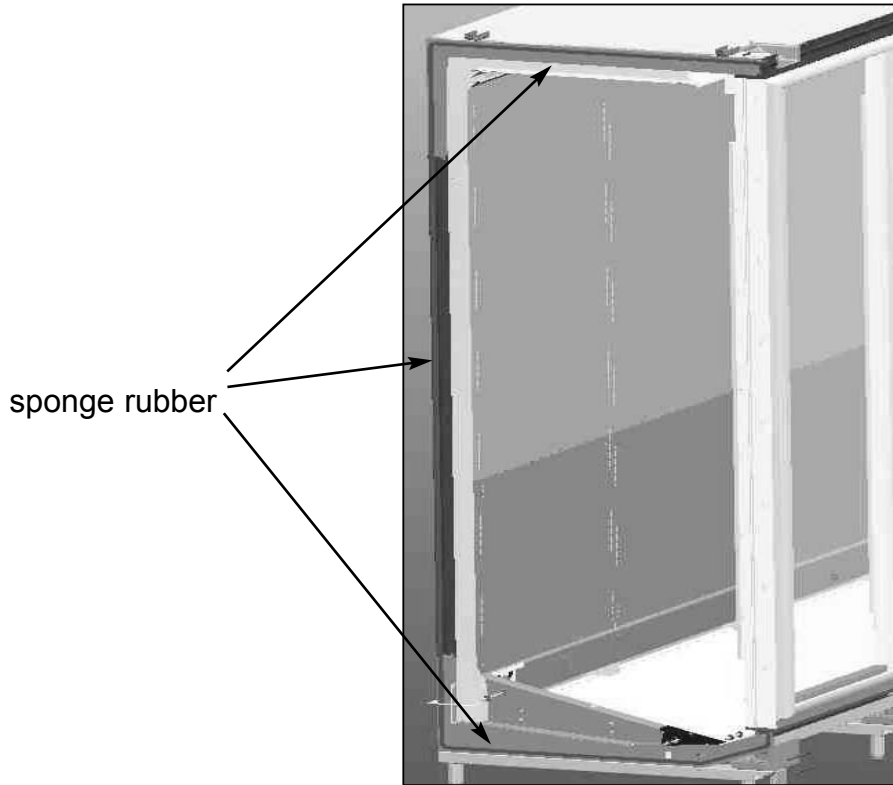

PLACE ALIGNMENT PINS

Insert two alignment pins into the canopy of one of the cabinets to be coupled.
Insert both plastic alignment joints in the steel bumper rail of one of the cabinets to be coupled.

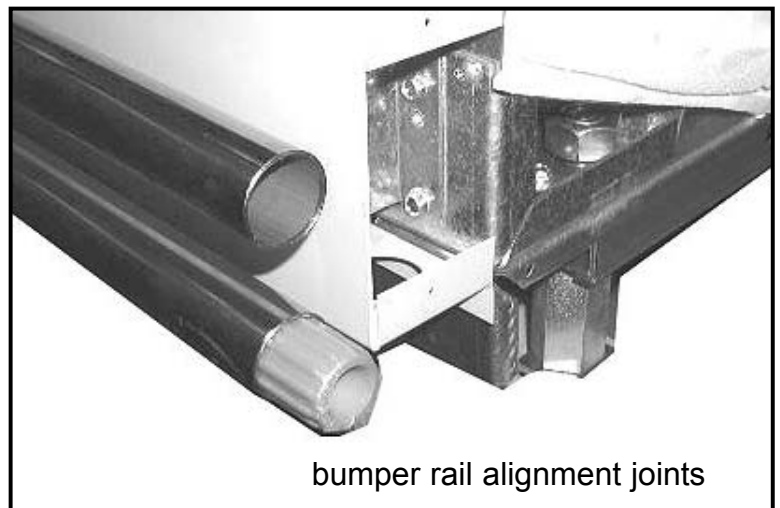
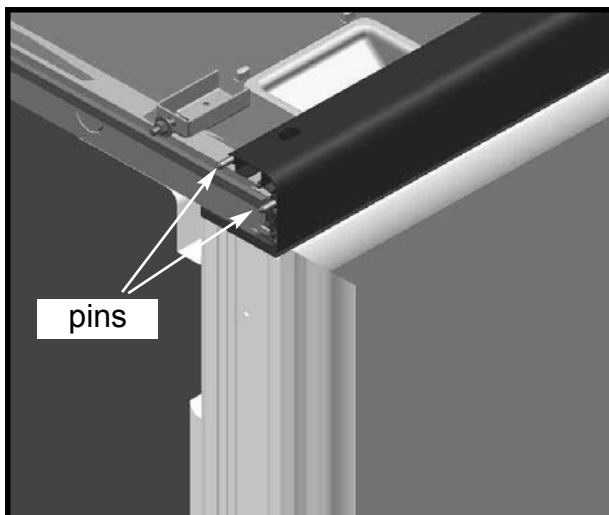

| | | | | | | |
|---------------------------------------|-------------------------|------|------|------|--------------------------------------|--|
| COSTAN TECHNICAL DOCUMENTATION | CHAPTER REVISION STATUS | | | | IN CONFORMITY WITH APPROVED ORIGINAL | PAGE: 4/6 |
| | ORD. | DATE | ORD. | DATE | | DATE of 1st ISSUE: 21.Jan.04 |
| PRODUCT: ELEPHANT GV | A | | D | | ISSUED BY MKT | |
| CHAP. No. 10 N° DOC. QSM000095E | B | | E | | | |
| CHAPTER: MULTIPLEXING CABINETS | C | | F | | | |

BRING THE CABINETS TOGETHER AND FASTEN THEM TO EACH OTHER

Secure the upper parts of the cabinets to each other using the two brackets on the roof plus hex-head bolts and nuts M6x80.

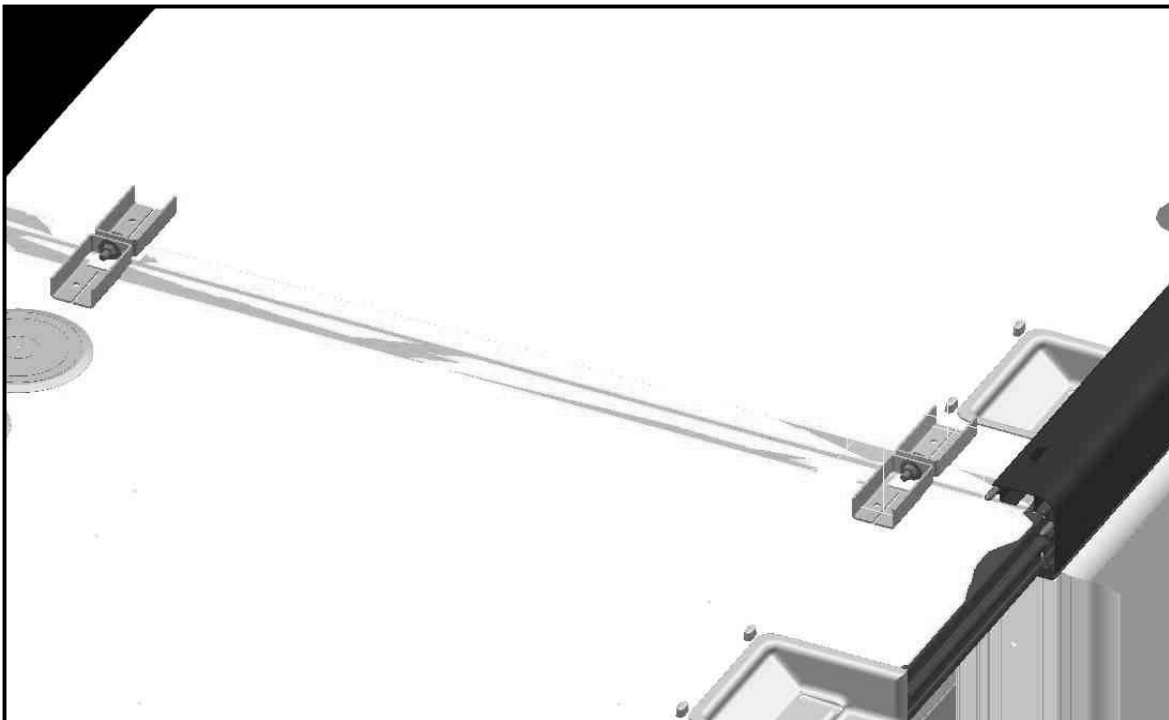
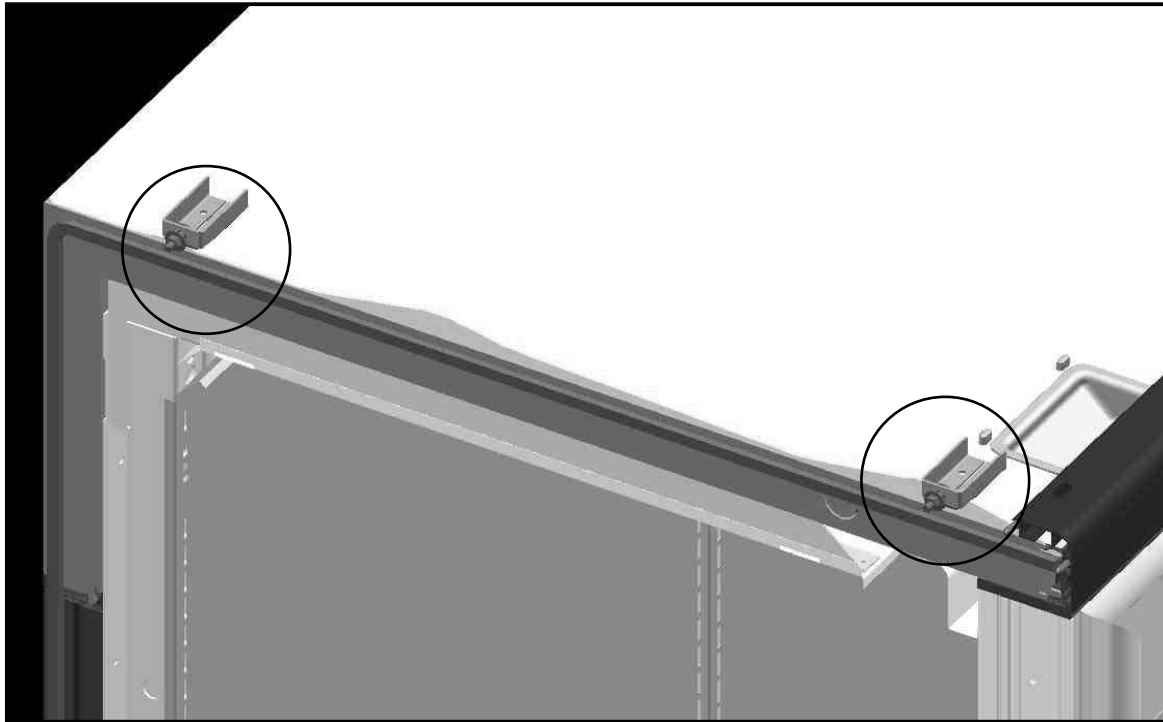

| | | | | | | |
|---------------------------------------|-------------------------|------|------|------|--------------------------------------|--|
| COSTAN TECHNICAL DOCUMENTATION | CHAPTER REVISION STATUS | | | | IN CONFORMITY WITH APPROVED ORIGINAL | PAGE: 5/6 |
| | ORD. | DATE | ORD. | DATE | | DATE of 1st ISSUE: 21.Jan.04 |
| PRODUCT: ELEPHANT GV | A | | D | | ISSUED BY MKT | |
| CHAP. no. 10 DOC. no. QSM000095E | B | | E | | | |
| CHAPTER: MULTIPLEXING CABINETS | C | | F | | | |

Secure the cabinets to each other at the bottom in the three points highlighted in the figure using hex-head bolts and nuts M8x90.

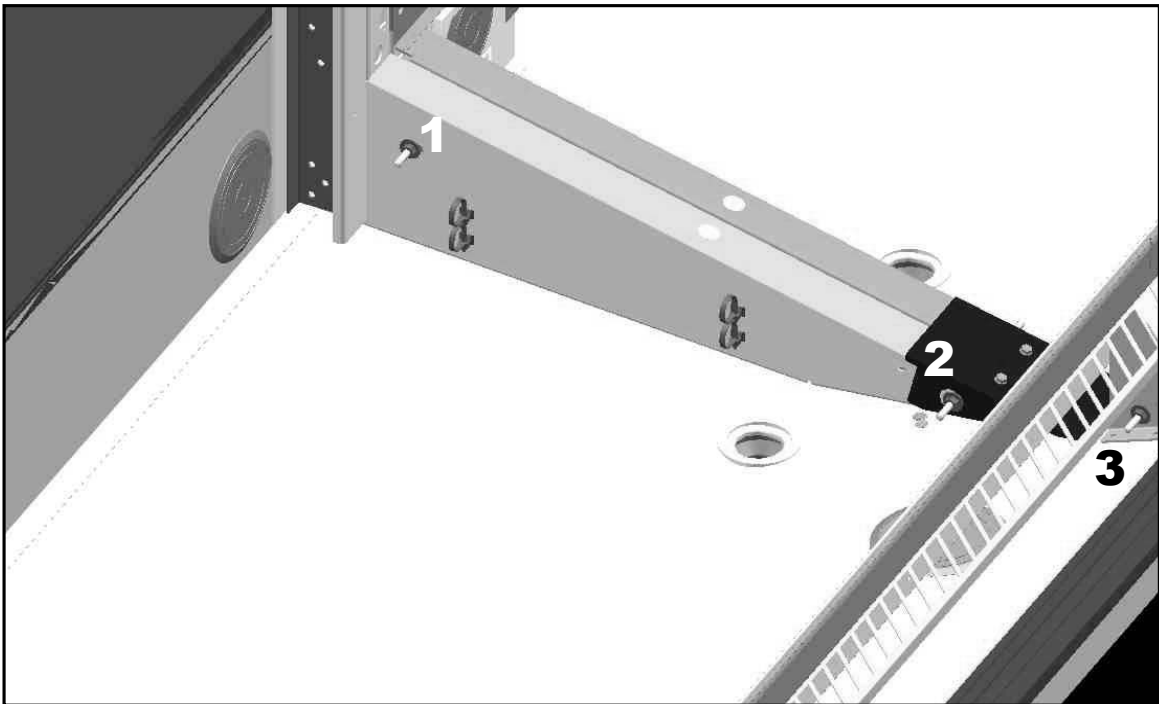
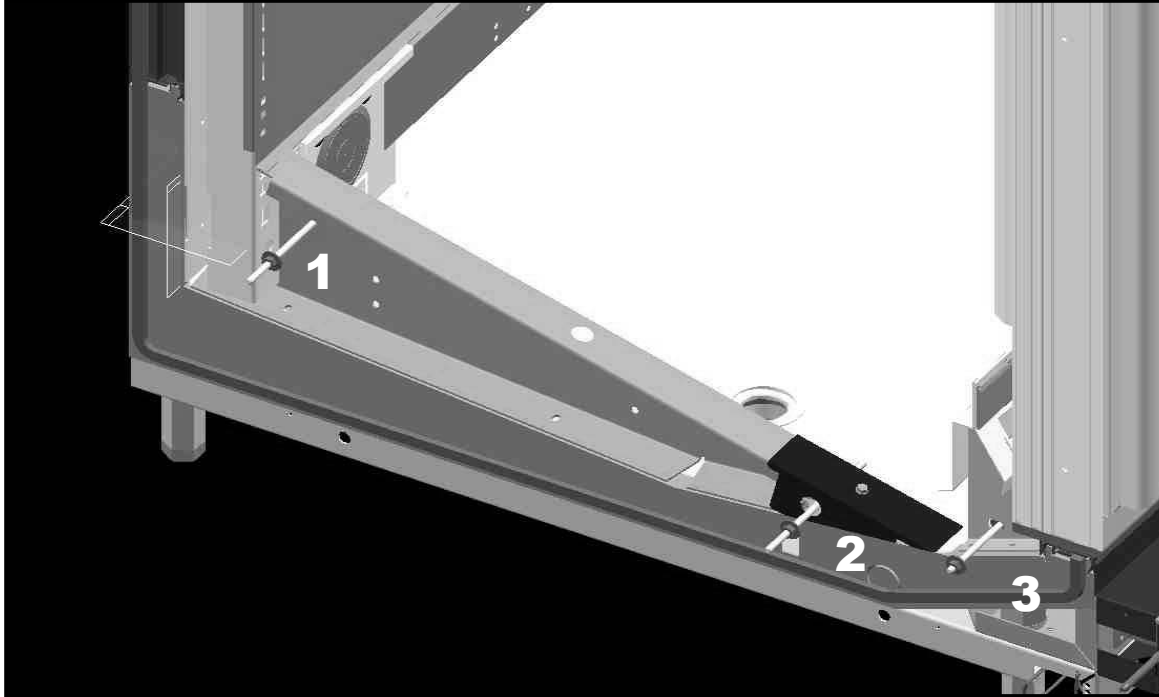

| | | | | | | |
|---------------------------------------|-------------------------|------|------|------|--------------------------------------|--|
| COSTAN TECHNICAL DOCUMENTATION | CHAPTER REVISION STATUS | | | | IN CONFORMITY WITH APPROVED ORIGINAL | PAGE: 6/6 |
| | ORD. | DATE | ORD. | DATE | | DATE of 1st ISSUE: 21.Jan.04 |
| PRODUCT: ELEPHANT GV | A | | D | | ISSUED BY MKT | |
| CHAP. No. 10 N° DOC. QSM000095E | B | | E | | | |
| CHAPTER: MULTIPLEXING CABINETS | C | | F | | | |

ADJUST PLINTHS

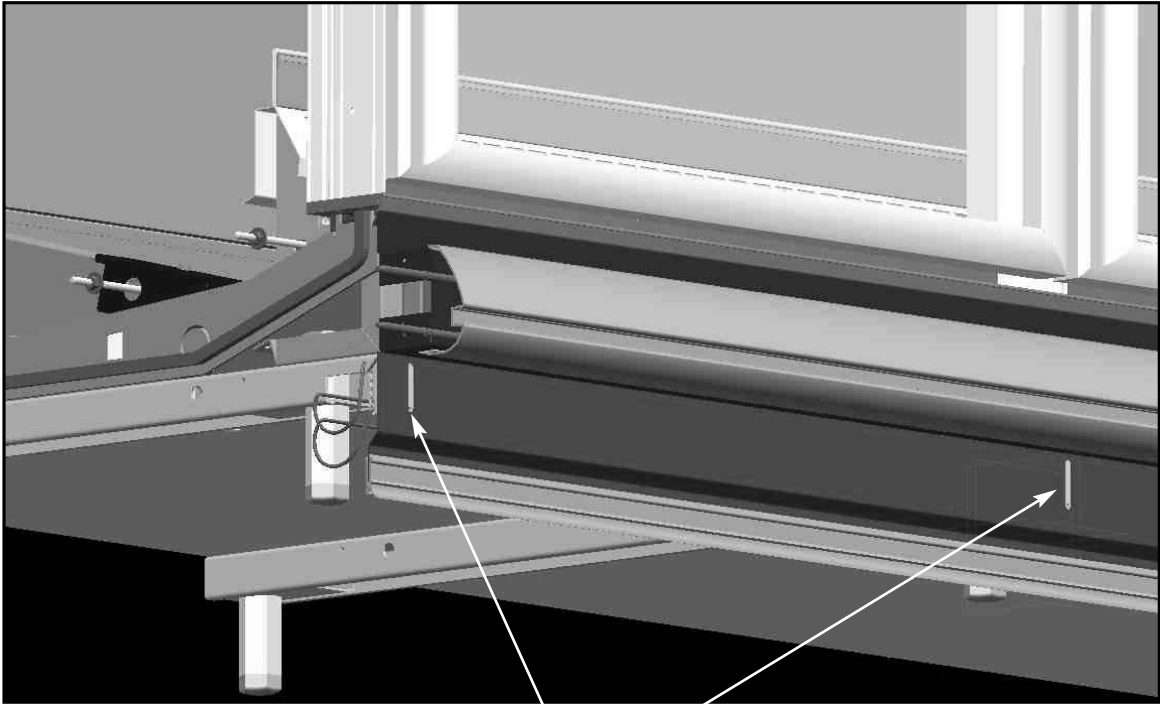

Adjust the height of front plinths using the bolts and slots existing on the plinths themselves.

| | | | | | | |
|--|-------------------------|------|------|------|--------------------------------------|--|
| COSTAN TECHNICAL DOCUMENTATION | CHAPTER REVISION STATUS | | | | IN CONFORMITY WITH APPROVED ORIGINAL | PAGE: 1/2 |
| | ORD. | DATE | ORD. | DATE | | DATE of 1st ISSUE: 21.Jan.04 |
| PRODUCT: ELEPHANT GV | A | | D | | ISSUED BY MKT | |
| CHAP. No. 11 DOC. no. QSM000095E | B | | E | | | |
| CHAPTER: PLACEMENT OF WATER DRAINS | C | | F | | | |

PLACEMENT OF WATER DRAINS

First position contemplated for the placement of the water drain.

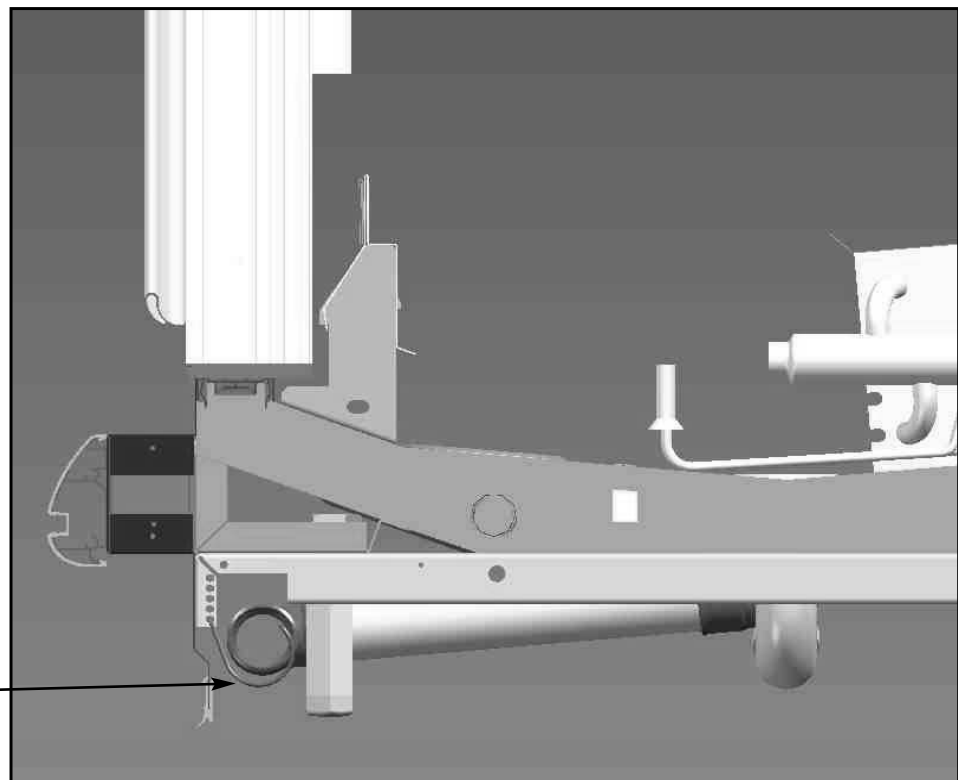
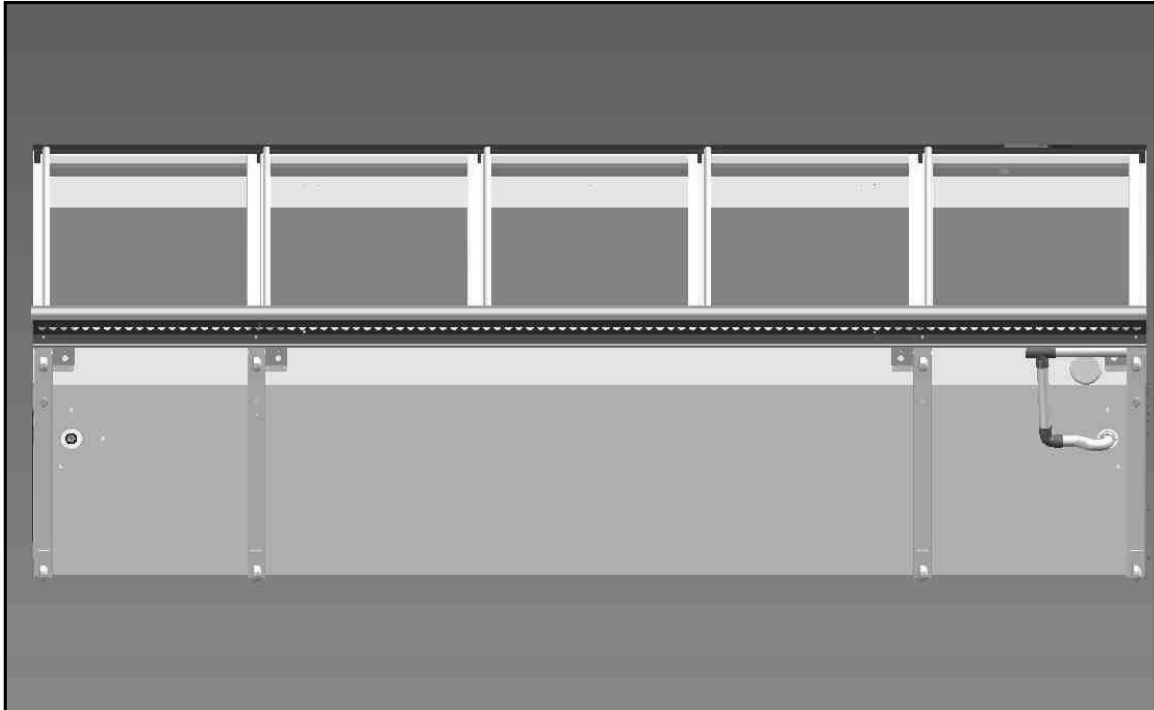

Adjustment of
drain piping
slope.

| | | | | | | |
|---------------------------------------|-------------------------|------|------|------|--------------------------------------|--|
| COSTAN TECHNICAL DOCUMENTATION | CHAPTER REVISION STATUS | | | | IN CONFORMITY WITH APPROVED ORIGINAL | PAGE: 2/2 |
| | ORD. | DATE | ORD. | DATE | | DATE of 1st ISSUE: 21.Jan.04 |
| PRODUCT: ELEPHANT GV | A | | D | | ISSUED BY MKT | |
| CHAP. No. 11 N° DOC. QSM000095E | B | | E | | | |
| CHAPTER: PLACEMENT OF WATER DRAINS | C | | F | | | |

Second position contemplated for the placement of the water drain.

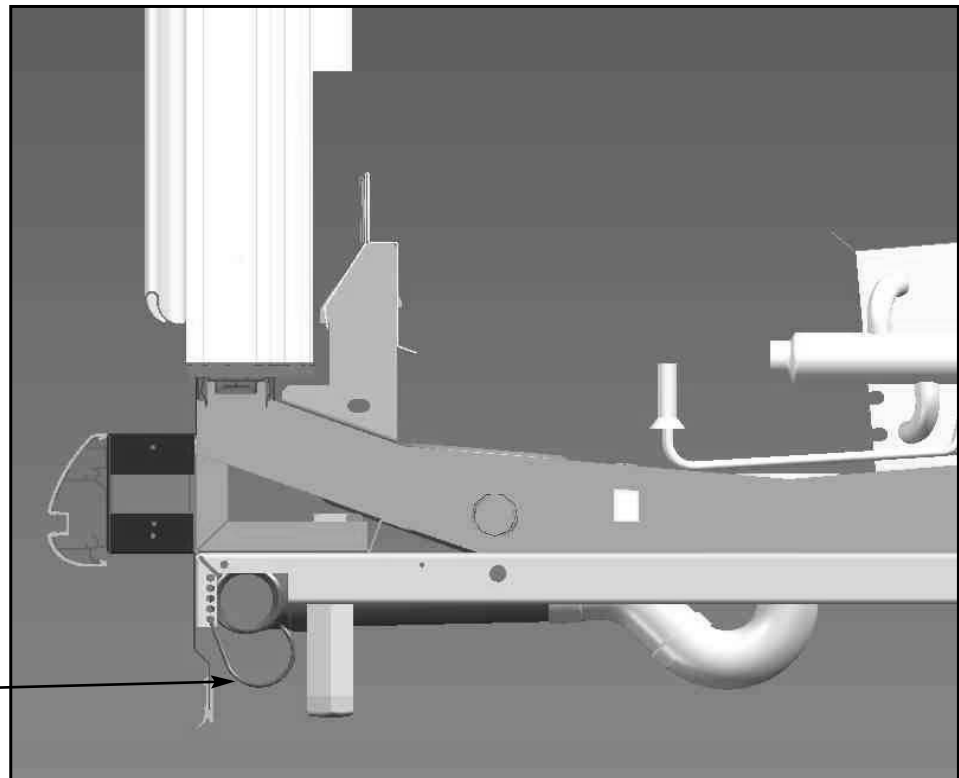
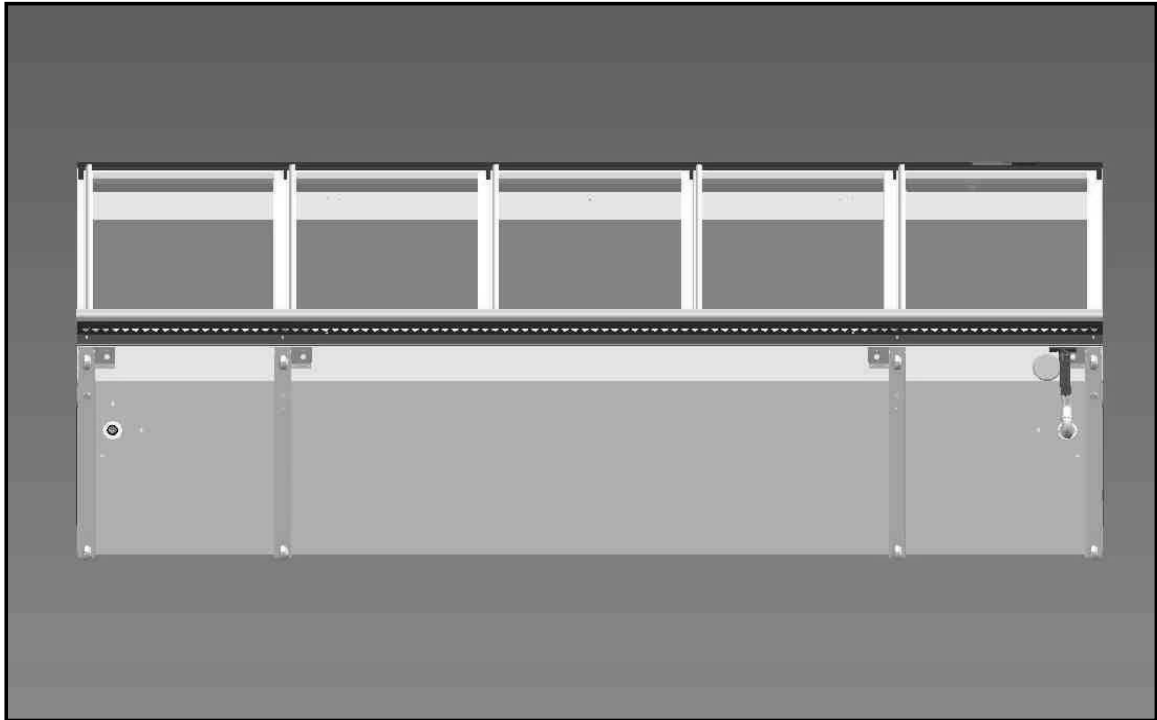

Adjustment of
drain piping
slope.