

frost-trol

FTS - AV07A00 105

MISTRAL HPV-S-PAE

Vitrina tradicional
 Traditional serve over
 Vitrine traditionnelle
 K htheke

CLASE 3M1
 3M2
 S/ EN 441 - 4-6

VENTO LINE

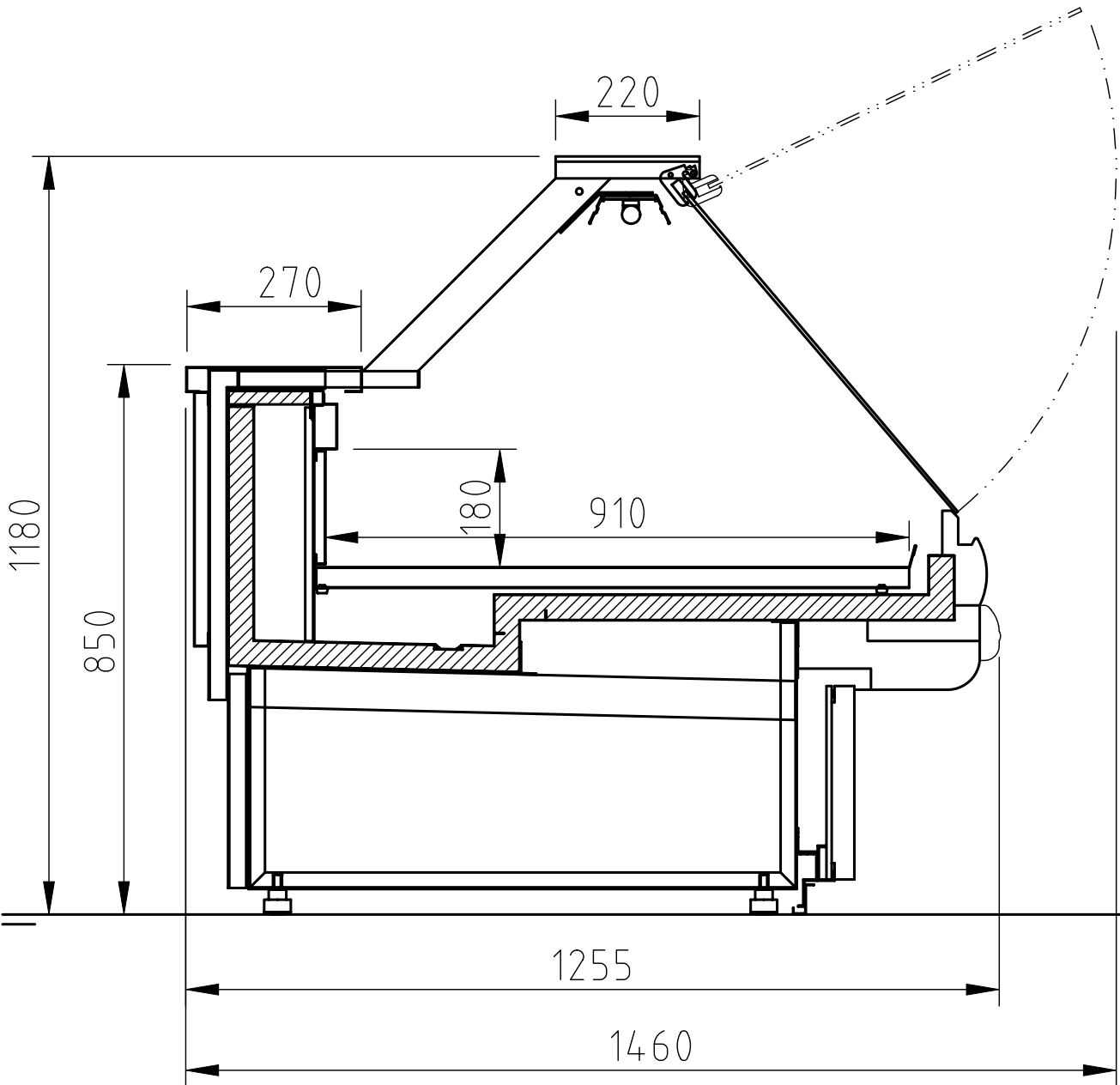

Modelos y caracter sticas pueden variar sin previo aviso - Subject to change without prior notice - Caract ristiques et mod les pouvant  tre modifi s sans pr avis - Technische Ver nderungen vorbehalten

SEG N LA NORMA EUROPEA • IN ACCORDANCE WITH EUROPEAN STANDARD
 EN CONFORMIT  AVEC LA NORME EUROP ENNE • GEM B DER EUROP ISCHEN NORM

EN 441 - 3

M DULO MODULE MODULE MODUL

Dimensiones exteriores Overall dimensions Dimensions hors tout Au�enma�e	Incremento por lateral • increase for each gable end accroissement par joue • Verl�ngerung mit einem Seitenteil +85	937	1250	1875	2500	3125	3750	DATE 2005
	Incremento lateral intermedio • increase for each intermediate end accroissement par joue interm�diaire • Verl�ngerung mit einem Innenseitentell +50							
Volumen �til • Useful volume • Volume utile • Nutzraum	largo • length • longueur • L�nge	937	1250	1875	2500	3125	3750	mm
	alto x ancho • height x depth • haut x larg • H�he x Breite	1180x1225						mm
TDA • Apertura expo. • Total Display Area • Surface totale d'exposition • Gesamtdisplayfl�che		0.147	0.196	0.294	0.393	0.491	0.589	m ³
Sup. carga • Load area • Aire chargement • Auslagefl�che		0.63	0.85	1.27	1.69	2.11	2.53	m ²
		0.85	1.14	1.71	2.18	2.84	3.41	m ²