

Technical brochure

Electronically operated evaporating pressure valve - KVQ



ADAP-KOOL®
Refrigeration control systems

Introduction



KVQ is an electronically operated evaporating pressure valve designed for small refrigerating systems. The KVQ valve is normally controlled by a controller from the Danfoss' range of ADAP-KOOL®- Refrigeration control system.

The KVQ valve consists of 2 main components:

- Actuator
- Valve

The valve can be used in small refrigerating systems, e.g. supermarket installations and cold rooms for fruit, vegetables and meat products.

The valve functions as an evaporating pressure valve. A modulating voltage signal is transmitted to the actuator from the controller. The signal is supplied in pulse sequences of up to 10 sec. duration. In this way a force is produced in the actuator's pressure container. This force will act on the charge in the bellows, move the pressure pin, and hence the valve plate.

The evaporating pressure rises when the valve closes. By varying the amount of power applied the controller ensures correct positioning of the valve plate. The evaporating pressure will therefore maintain the value resulting in the correct media temperature. Changes of the suction pressure are of no consequence, as the area of the bellows equals the orifice area. If the supply voltage is cut out, the valve opens.

Features

- Accurate pressure control
- Capacity: 8 to 19 kW (R22)
- All fluorinated refrigerants
- Regulating range: 0 - 7 bar

Approvals

C[®]US listed, fil SA7200

Technical data

Regulating range	$p_e = 0 \rightarrow 7$ bar		
Refrigerent temperature in regulating range	Refrigerant	$p_e = 0$ bar (p_e)	$p_e = 7$ bar (p_e)
	R 22	-41°C	15°C
	R 134a	-30°C	32.5°C
	R 404A	-47°C	10°C
	R 407C	-35°C	17°C
	R 507	-47°C	8°C
Refrigerants	CFC, HCFC and HFC		
Ambient temperature	During operation: -45 → +40°C During transport: -50 → +70°C		
Max. working pressure PB	21.5 bar		
Max. test pressure p'	28 bar		
Power supply	24 V pulsating a.c. from regulator		
Max. consumption	35 VA / 24 V a.c.		
Enclosure	IP 54 acc. to IEC 529		
Cable entry	Pg 13.5		

During forced closing by hot-gas defrosting

Max. closing pressure	17.5 bar
Max. hot gas temperature	120°C

Capacity

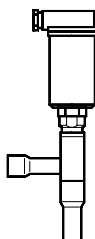

Refrigerant	t_e °C	Capacity in kW											
		KVQ 15-22						KVQ 28-35					
		Pressure drop Δp bar											
		0.05	0.1	0.2	0.3	0.5	0.7	0.05	0.1	0.2	0.3	0.5	0.7
R 22	-40	2.1	2.9	3.9	4.6	5.3	5.6	4.9	6.8	9.3	10.8	12.5	12.9
	-30	2.7	3.7	5.1	6.1	7.5	8.2	6.3	8.8	12.1	14.4	17.5	19.3
	-20	3.3	4.7	6.5	7.8	9.7	11.1	7.9	11.0	15.3	18.4	22.9	26.0
	-10	4.1	5.7	8.0	9.7	12.2	14.1	9.6	13.5	18.9	22.9	28.8	33.2
	0	4.9	6.9	9.7	11.8	14.9	17.4	11.6	16.3	22.9	27.8	35.3	41.0
	+10	5.8	8.2	11.6	14.1	17.9	21.0	13.8	19.4	27.3	33.2	42.3	49.5
R 134a	-30	1.8	2.6	3.5	4.1	4.7	4.9	4.4	6.1	8.2	9.6	11.0	11.2
	-20	2.4	3.3	4.6	5.5	6.6	7.2	5.7	7.9	10.9	12.8	15.5	17.0
	-10	3.1	4.3	6.0	7.2	8.9	10.0	7.3	10.2	14.1	17.0	21.0	23.6
	0	3.8	5.4	7.5	9.0	11.3	13.0	9.0	12.7	17.7	21.5	27.0	30.7
	+10	4.7	6.6	9.3	11.2	14.1	16.4	11.1	15.7	22.0	26.5	33.5	38.8
R 404A/ R 507	-40	1.8	2.4	3.3	3.9	4.7	5.0	4.1	5.8	7.9	9.2	11.0	11.9
	-30	2.2	3.2	4.5	5.3	6.5	7.3	5.4	7.5	10.4	12.4	15.3	17.2
	-20	2.9	4.0	5.6	6.8	8.5	9.7	6.8	9.4	13.2	15.9	20.0	22.9
	-10	3.6	5.1	7.2	8.7	10.9	12.7	8.6	12.1	16.9	20.5	26.0	30.0
	0	4.5	6.2	8.8	10.8	13.6	16.0	10.5	14.8	20.8	25.3	32.2	37.5
	+10	5.4	7.6	10.7	13.1	16.7	19.5	12.7	18.0	25.3	30.7	39.3	46.0
R 407C	-40	1.7	2.3	3.1	3.6	4.2	4.4	3.9	5.4	7.3	8.5	9.9	10.2
	-30	2.3	3.1	4.3	5.2	6.4	7.0	5.4	7.5	10.3	12.2	14.9	16.4
	-20	2.9	4.1	5.7	6.9	8.5	9.8	7.0	9.7	13.5	16.2	20.2	22.9
	-10	3.7	5.2	7.3	8.8	11.1	12.8	8.7	12.3	17.2	20.8	26.2	30.2
	0	4.6	6.5	9.1	11.1	14.0	16.4	10.9	15.3	21.5	26.1	33.2	38.5
	+10	5.6	8.0	11.3	13.7	17.4	20.4	13.4	18.8	26.5	32.2	41.0	48.0

1 kW = 0,284 ton (TR)

The values in the capacity table refer to the evaporator capacity and are based on liquid temperature $t_l = +25^\circ\text{C}$ ahead of the thermostatic expansion valve.
Dry, saturated vapour ahead of the KVQ valve is assumed.

Correction factors for liquid temperature t_l

t_l °C	10	15	20	25	30	35	40	45	50
R 134a	0.88	0.92	0.96	1.0	1.05	1.10	1.16	1.23	1.31
R 22	0.90	0.93	0.96	1.0	1.05	1.10	1.13	1.18	1.24
R 404A/ R 507	0.84	0.89	0.94	1.0	1.07	1.16	1.26	1.40	1.57
R 407C	0.88	0.91	0.95	1.0	1.05	1.11	1.18	1.26	1.35

Sizing

For optimum performance, it is important to select a KVQ valve according to system conditions and application. The selection is also dependant on the acceptable pressure drop across the valve. The following data must be used:

- Refrigerant
- Evaporator capacity Q_e in kW
- Evaporating temperature t_e in °C
- Liquid temperature ahead of expansion valve t_l in °C
- Max. acceptable pressure drop in the valve in bar
- Connection size in inches or mm.

Valve selection Example

When selecting the appropriate valve it may be necessary to convert the actual evaporator capacity using a correction factor. This is required when your system conditions are different than the table conditions. The selection is also dependant on the acceptable pressure drop across the valve. The following example illustrates how this is done.

Refrigerant: R 22
 Evaporator capacity: $Q_e = 20$ kW
 Evaporating temperature: $t_e = 0^\circ\text{C} \sim 4.0$ bar
 Liquid temperature ahead of expansion valve:
 $t_l = 35^\circ\text{C}$
 Max. pressure drop in the valve $\Delta p = 0.2$ bar
 Connection type: Solder
 Connection size: $1 \frac{1}{8}$ in.

Valve selection Step 1

Determine the correction factor for liquid temperature t_l ahead of expansion valve.

From the correction factors table (see below) a liquid temperature of 35°C , R 22 corresponds to a factor of 1.10.

Correction factors for liquid temperature t_l

t_l °C	10	15	20	25	30	35	40	45	50
R 134a	0.88	0.92	0.96	1.0	1.05	1.10	1.16	1.23	1.31
R 22	0.90	0.93	0.96	1.0	1.05	1.10	1.13	1.18	1.24
R 404A/ R 507	0.84	0.89	0.94	1.0	1.07	1.16	1.26	1.40	1.57
R 407C	0.88	0.91	0.95	1.0	1.05	1.11	1.18	1.26	1.35

Step 2

Corrected evaporator capacity is
 $Q_e = 20 \times 1.1 = 22$ kW

Step 3

Now select the appropriate capacity table R 22 and choose the column for an evaporating temperature of $t_e = 0^\circ\text{C}$.

Using the corrected evaporator capacity, select a valve that provides an equivalent or greater capacity at an acceptable pressure drop across the valve of 0.2 bar.

KVQ 28/35 delivers 22.9 kW at a 0.2 bar pressure drop across the valve.

Based on the required connection size of $1 \frac{1}{8}$ in., the KVQ 28 is the proper selection for this example.

Step 4

KVQ 28, $1 \frac{1}{8}$ in. solder connection:
code no. 034L0115 and actuator
code no. 034L0106, see Ordering

Ordering

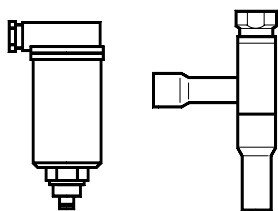

Type	Rated capacity ¹⁾ kW				Valve			Actuator
					Connection		Code no.	Code no.
	R 22	R 134a	R 404A/R 507	R 407C	mm	in.		
KVQ 15	8.0	6.0	7.2	7.3	16	5/8	034L0117	034L0105
KVQ 22	8.0	6.0	7.2	7.3	22	7/8	034L0114	
KVQ 28	18.9	14.1	16.9	17.2	28		034L0119	034L0106
KVQ 35					35	1 1/8	034L0115	
						1 3/8	034L0120	

¹⁾ Rated capacity is the valve capacity at evaporating temperature $t_e = -10^\circ\text{C}$, condensing temperature $t_c = +25^\circ\text{C}$ and pressure drop across valve $\Delta p = 0.2 \text{ bar}$.
1 kW = 0.284 ton (TR).

Design

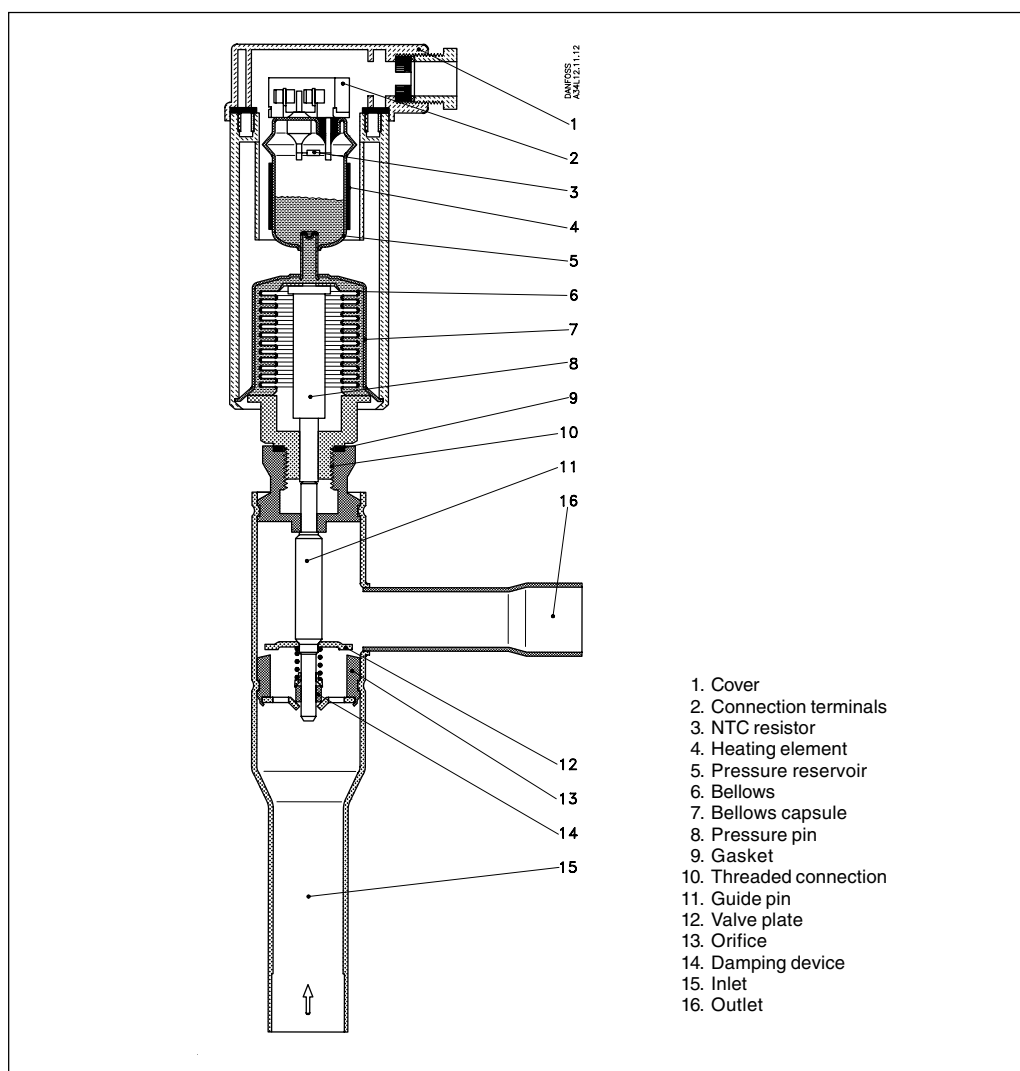

1. Cover
2. Connection terminals
3. NTC resistor
4. Heating element
5. Pressure reservoir
6. Bellows
7. Bellows capsule
8. Pressure pin
9. Gasket
10. Threaded connection
11. Guide pin
12. Valve plate
13. Orifice
14. Damping device
15. Inlet
16. Outlet

Dimensions and weights

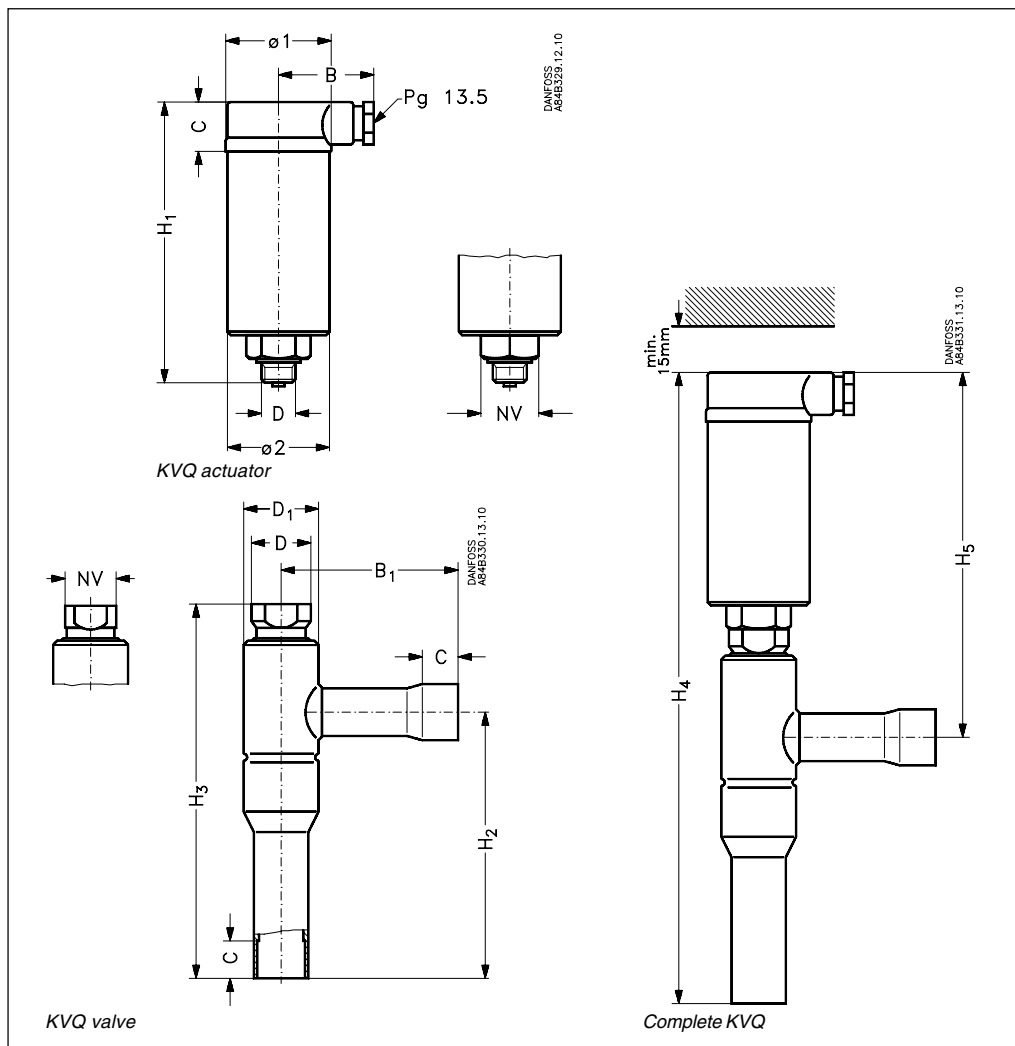

KVQ actuator

Type	H_1 mm	B mm	C mm	NV mm	D mm	D 1 mm	D 2 mm	Weight kg
KVQ 15-22	162.5	54	27	32	M16 × 1.5	63	60	0.5
KVQ 28-35	162.5	54	27	32	M18 × 1.5	63	60	0.5

KVQ valve

Type	Connect. Solder		Total mm	H_2 mm	H_3 mm	B_1 mm	C mm	D_1 mm	D mm	NV mm	Weight kg
	in.	mm									
KVQ 15	5/8	16	303	99	154	64	12	30	28	24	0.4
KVQ 22	7/8	22	303	99	154	64	17	30	28	24	0.4
KVQ 28	1 1/8		366	151	215	105	22	43	35	30	0.9
KVQ 28		28	366	151	215	105	22	43	35	30	0.9
KVQ 35	1 3/8	35	366	151	215	105	25	43	35	30	0.9

Complete KVQ

Type	H_4 mm	H_5 mm
KVQ 15-22	303	204
KVQ 28-35	366	211

Danfoss can accept no responsibility for possible errors in catalogues, brochures and other printed material. Danfoss reserves the right to alter its products without notice. This also applies to products already on order provided that such alterations can be made without subsequential changes being necessary in specifications already agreed. All trademarks in this material are property of the respective companies. Danfoss and the Danfoss logotype are trademarks of Danfoss A/S. All rights reserved.



**DK-6430 Nordborg
Denmark**

