

Danfoss

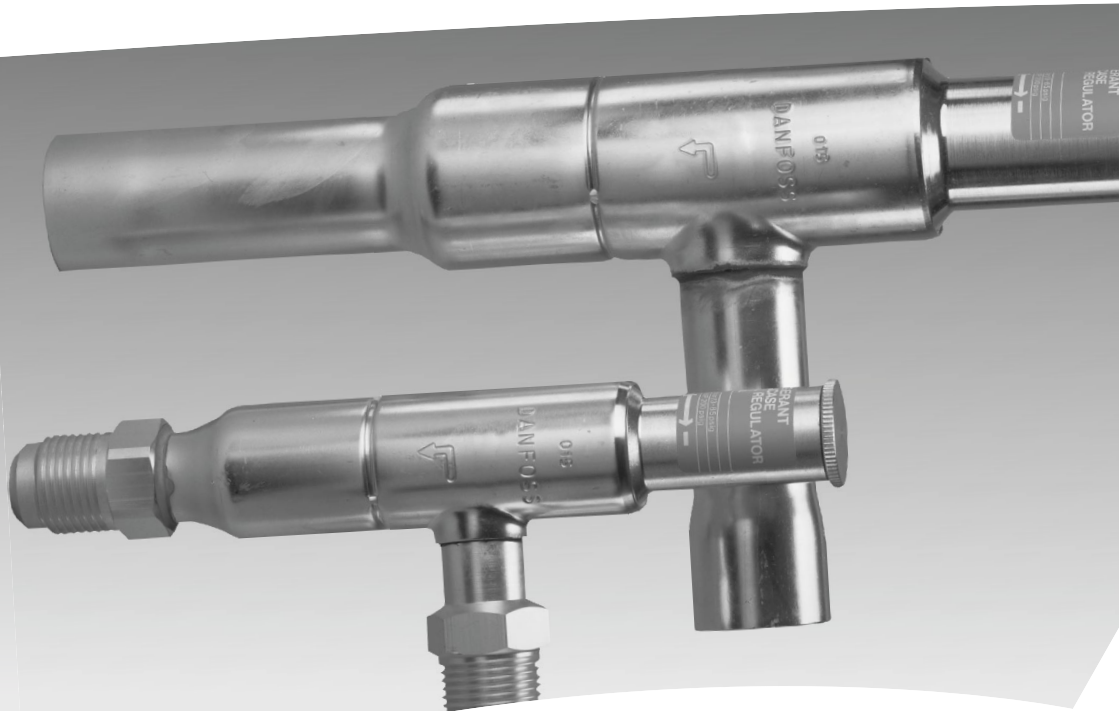

KV pressure regulators

REFRIGERATION AND
AIR CONDITIONING

Fitters notes

Contents	Page
Application	3
KVP evaporating pressure regulator	3
KVR condensing pressure regulator	4
KVL crankcase pressure regulator.....	5
KVC capacity regulator	6
KVD receiver pressure regulator.....	7
Identification	7
Installation	8
Soldering/brazing	8
Pressure testing.....	9
Evacuation	9
Setting	10
KVP evaporating pressure regulators.....	10
KVL crankcase pressure regulators.....	11
KVR + NRD condensing pressure regulator	11
KVR + KVD condensing pressure regulator	12
Fault location	13
Danfoss pressure regulators.....	15

Application

Type KV pressure regulators will control the low and high pressure sides of the system under varying load conditions:

- KVP is used as an evaporating pressure regulator.
- KVR is used as a condensing pressure regulator.
- KVL is used as a crankcase pressure regulator.
- KVC is used as a capacity regulator.
- KVD is used as a receiver pressure regulator.
- NRD is used as a differential pressure regulator.



Ak0_0031

KVP evaporating pressure regulator

The evaporating pressure regulator is installed in the suction line after the evaporator to regulate the evaporating pressure in refrigeration systems with one or more evaporators and one compressor.

In such refrigeration systems (operating on different evaporating pressures) KVP is installed after the evaporator with the highest evaporating pressure.

To prevent refrigerant migration during standstill, remember to install an NRV check valve in the suction line after the evaporator with the lowest evaporating pressure.

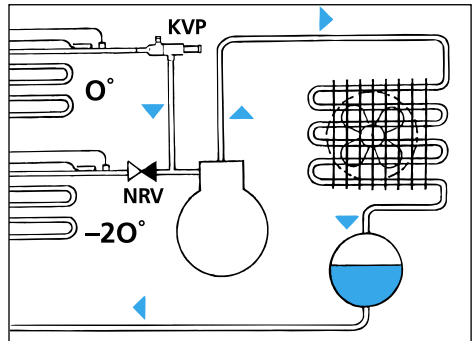

Ak0_0025

In refrigeration systems with parallel coupled evaporators and common compressors, and where the same evaporating pressure is required, KVP must be installed in the common suction line.

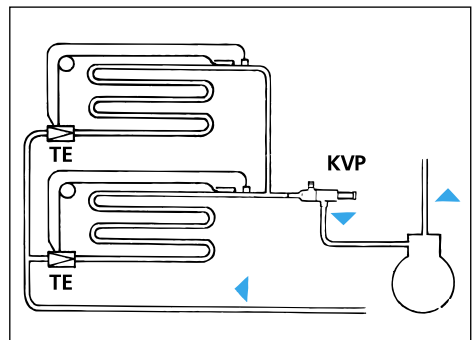

Ak0_0019

The KVP evaporating pressure regulator has a pressure gauge connection for use when setting the evaporating pressure. KVP maintains constant pressure in the evaporator.

KVP opens on rising inlet pressure (evaporating pressure).

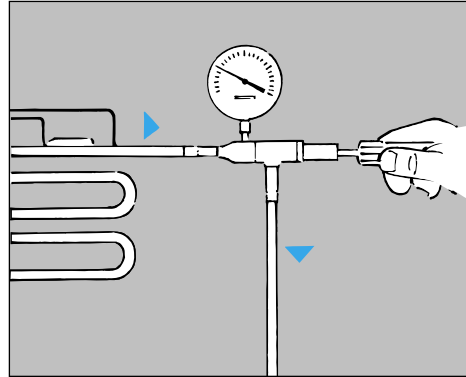

Ak0_0023

KVR condensing pressure regulator

KVR is normally installed between the air-cooled condenser and the receiver. KVR maintains constant pressure in air-cooled condensers. It opens on rising inlet pressure (condensing pressure).

KVR together with a KVD or an NRD ensures a sufficiently high liquid pressure in the receiver during varying operating conditions.

The KVR condensing pressure regulator has a pressure gauge connection for use when setting the condensing pressure.

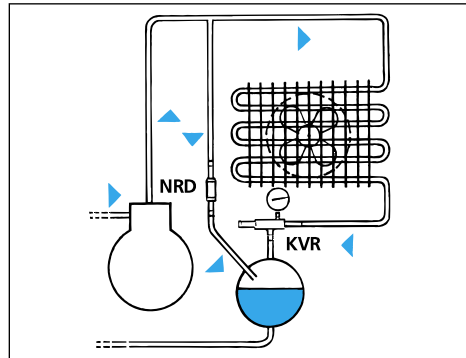

Ak0_0026

In situations where both the air-cooled condenser and the receiver are located outdoors in very cold surroundings it can be difficult to start the refrigeration system after a long standstill period.

In such conditions, KVR is installed ahead of the air-cooled condenser, with an NRD in a bypass line around the condenser.

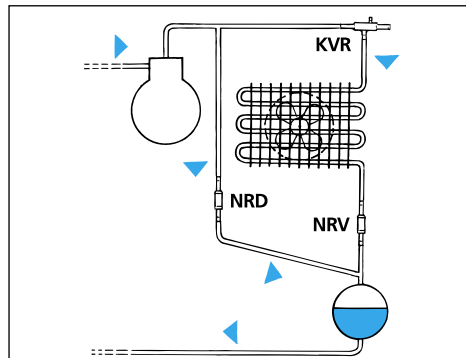

Ak0_0027

KVR is also used in heat recovery. In this application, KVR is installed between the heat recovery vessel and condenser.

It is necessary to install an NRV between condenser and receiver in order to prevent back-condensation of the liquid in the condenser.

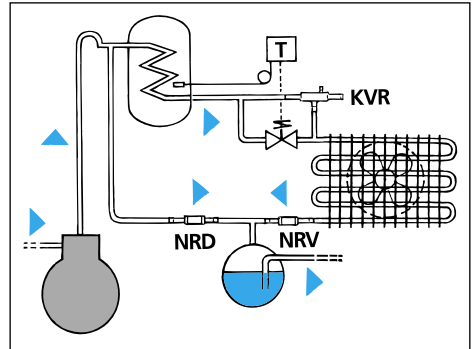

Ak0_0028

KVR can be used as a relief valve in refrigeration systems with automatic defrosting. Here, KVR is installed between the outlet tube from evaporator and receiver.

Note!

KVR must never be used as a safety valve.

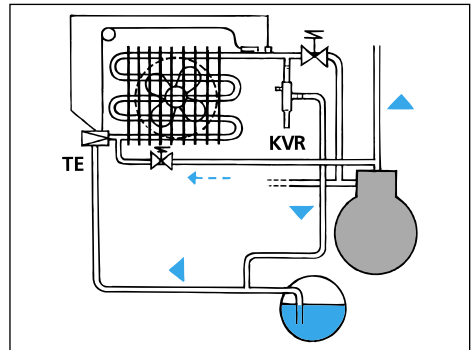

Ak0_0029

KVL crankcase pressure regulator

KVL crankcase pressure regulator limits compressor operation and start-up if the suction pressure becomes too high.

It is installed in the refrigeration system suction line immediately ahead of the compressor.

KVL is often used in refrigeration systems with hermetic or semihermetic compressors designed for low-temperature ranges.

KVL opens on falling outlet pressure (suction pressure).

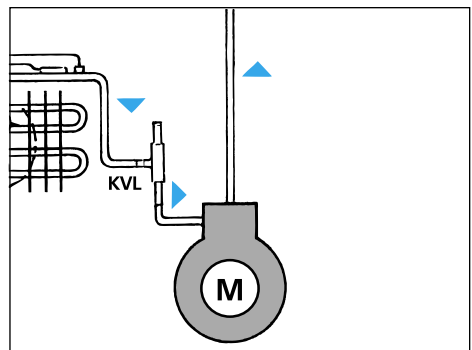

Ak0_0024

KVC capacity regulator

KVC is used for capacity regulation in refrigeration systems where low-load situations occur and where it is necessary to avoid low suction pressure and “compressor cycling”.

Too low a suction pressure will also cause vacuum in the refrigeration system and thus create the risk of moisture ingress in refrigeration systems with open compressor. KVC is normally installed in a bypass line between compressor discharge tube and suction tube. KVC opens on falling outlet pressure (suction pressure).

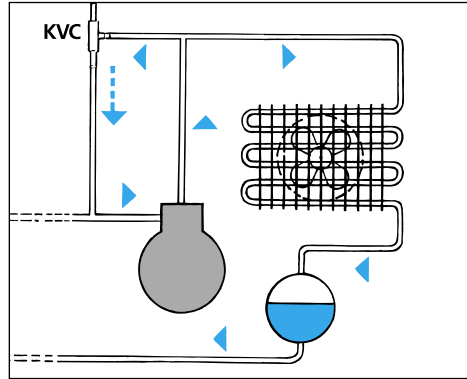

Ak0_0030

A CPCE capacity regulator can be used as an alternative to KVC if the requirement is greater accuracy in the regulation of low suction pressure.

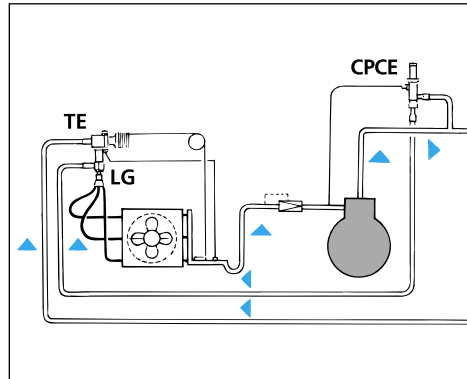

Ak0_0002

KVC can also be installed in a bypass line from the compressor discharge pipe, with valve outlet led to a point between expansion valve and evaporator.

This arrangement can be used on a liquid cooler with several parallelcoupled compressors and where no liquid distributor is used.

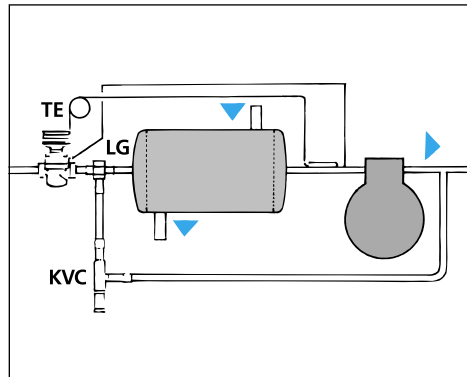

Ak0_0003

KVD receiver pressure regulator

KVD is used to maintain sufficiently high receiver pressure in refrigeration systems with or without heat recovery.

KVD is used together with a KVR condensing pressure regulator.

The KVD receiver pressure regulator has a pressure gauge connection for use when setting receiver pressure.

KVD opens on falling outlet pressure (receiver pressure).

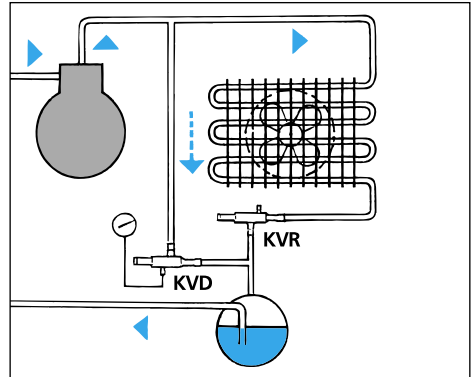

Ak0_0004

Identification

All KV pressure regulators carry a label giving the valve function and type, e.g. CRANKCASE PRESS. REGULATOR type KVL.

The label also gives the operating range of the valve and its max. permissible working pressure (PS/MWP).

A double-ended arrow (“+” and “-”) is printed on the bottom of the label. Direction “+” (plus) means higher pressure and “-” (minus) means lower pressure.

KV pressure regulators can be used with all existing refrigerants except ammonia (NH₃), provided valve pressure ranges are respected.

The valve body is stamped with the valve size, e.g. KVP 15, with an arrow to indicate valve flow direction.

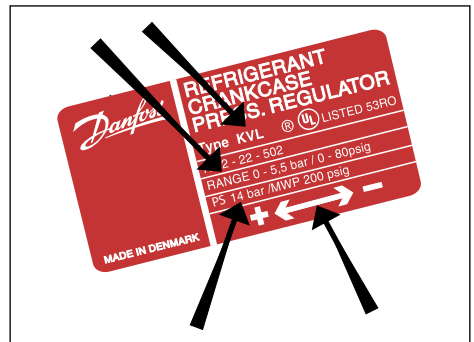

Ak0_0032

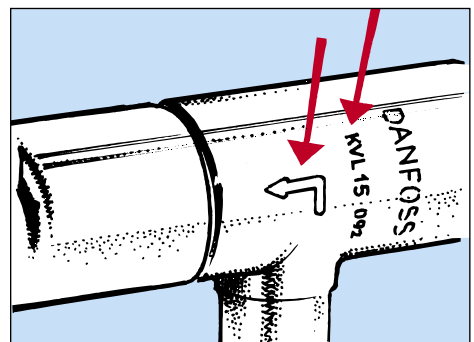

Ak0_0005

Installation

Ensure that piping around KV valves is clean and well-secured. This will protect valves against vibration.

All KV pressure regulators must always be installed so that flow is in the direction of the arrow.

KV pressure regulators can otherwise be installed in any position, but they must never be able to create an oil or liquid lock.

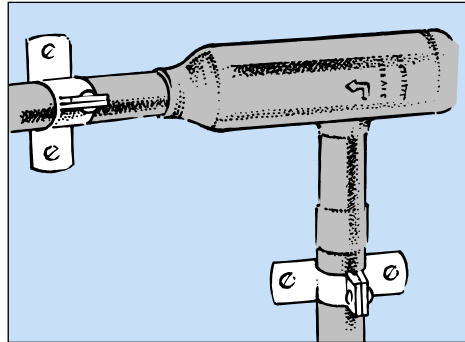

Ak0_0006

Soldering/brazing

During soldering, it is important to wrap a wet cloth around the valve.

Always point the gas flame away from the valve so that the valve is never subjected to direct heat. When soldering, be careful not to leave soldering material in the valve as this can impair function.

Before soldering a KV valve, be sure that any pressure gauge insert has been removed. Always use inert gas when soldering KV valves.

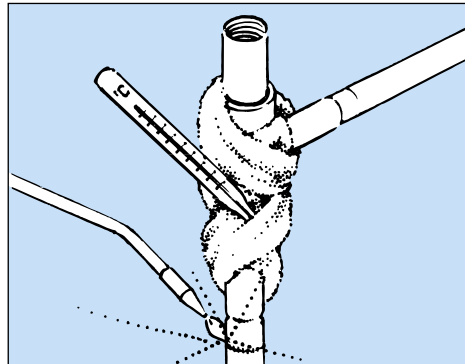

Ak0_0007



Warning!

Alloys in soldering materials and flux give off smoke which can be hazardous to health. Please read suppliers' instructions and follow their safety precautions. Keep the head away from the smoke during soldering. Use good ventilation and/or an extract at the flame and do not inhale smoke and gases. It is a good idea to use safety goggles.

Soldering while refrigerant is present in the system is not recommended.

Aggressive gases might be created which can, for example, break down the bellows in KV valves or other parts in the refrigeration system.

Pressure testing

KV pressure regulators can be pressure-tested after they have been installed, provided the test pressure does not exceed the maximum permissible pressure on the valves.

The maximum test pressure for KV valves is shown in the table.

Type	Test pressure, bar
KVP 12 - 15 - 22	28
KVP 28 - 35	25
KVL 12 - 15 - 22	28
KVL 28 - 35	25
KVR 12 - 15 - 22	31
KVR 28 - 35	31
KVD 12 - 15	31
KVC 12 - 15 - 22	31

Evacuation

During evacuation of the refrigeration system, all KV valves must be open.

Factory-set KV valves will have the following positions when supplied:

- KVP, closed
- KVR, closed
- KVL, open
- KVC, open
- KVD, open

It is therefore necessary to screw the set-ting spindle of KVP and KVR right back counter-clockwise during system evacuation.

In individual cases it can be necessary to evacuate from both discharge side and low-pressure side in the refrigeration system.

Evacuation through the pressure gauge connections of KVP, KVR and KVD is not advisable because the orifice in these ports are very small.

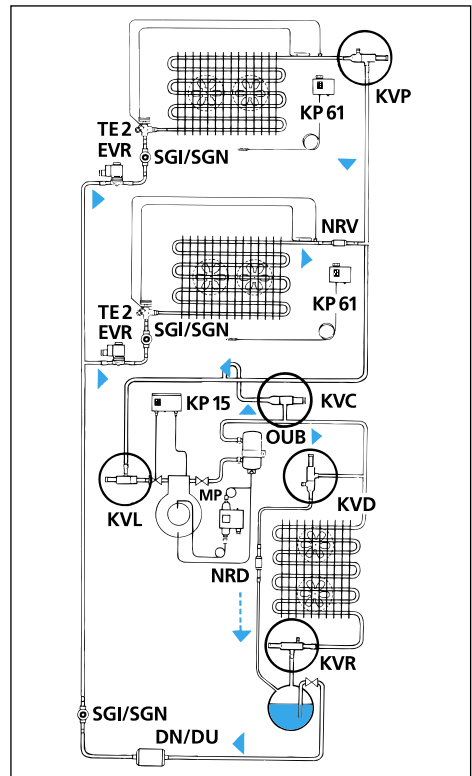

Ak0_0009

Setting

When setting KV pressure regulators in refrigeration systems it can be a good idea to use the factory setting as the starting-out point.

The factory setting for individual pressure regulators can be found again by measuring from the top of the valve to the top of the setting screw.

The table shows the factory setting, the distance "x" and the pressure change per revolution of the setting screw for all KV types.

Type	Factory setting	X mm	bar/rev.
KVP 12 - 15 - 22	2	13	0.45
KVP 28 - 35	2	19	0.30
KVL 12 - 15 - 22	2	22	0.45
KVL 28 - 35	2	32	0.30
KVR 12 - 15 - 22	10	13	2.5
KVR 28 - 35	10	15	1.5
KVD 12 - 15	10	21	2.5
KVC 12 - 15 - 22	2	13	0.45

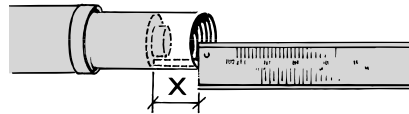

Ak0_0010

KVP evaporating pressure regulators

KVP evaporating pressure regulators are always supplied with a factory setting of 2 bar. Turning clockwise gives higher pressure and turning counterclockwise gives lower pressure.

After the system has been in normal operation for a time, fine adjustment is necessary. Always use a pressure gauge when making fine adjustments.

If KVP is used for frost protection, fine adjustment must be made when the system is operating under minimum load.

Remember to always replace the protective cap on the setting screw after final setting.

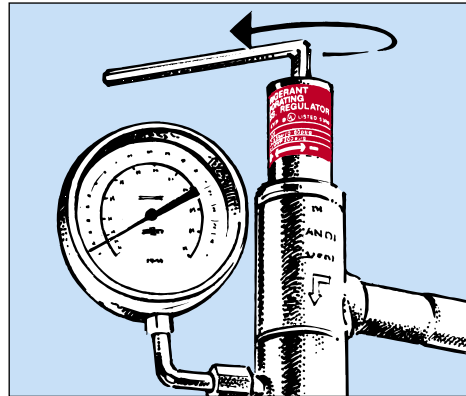

Ak0_0011

KVL crankcase pressure regulators

KVL crankcase pressure regulators are always supplied with a factory setting of 2 bar.

Turning clockwise gives higher pressure and turning counterclockwise gives lower pressure.

The factory setting is the point at which KVL begins to open or where it just closes. Since the compressor must be protected, the KVL setting is the max. permissible suction pressure of the compressor.

The setting must be made using the compressor suction pressure gauge.

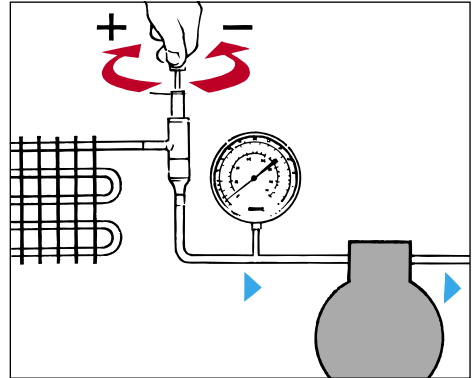

Ak0_0012

KVR + NRD condensing pressure regulator

In refrigeration systems with KVR + NRD, the setting of KVR must give a suitable receiver pressure.

Pressure in the condenser of between 1.4 and 3.0 bar (pressure drop across NRD) higher than the pressure in the receiver should be acceptable. If it cannot be accepted, an arrangement with KVR + KVD must be used.

This setting is best made during operating in a winter period.

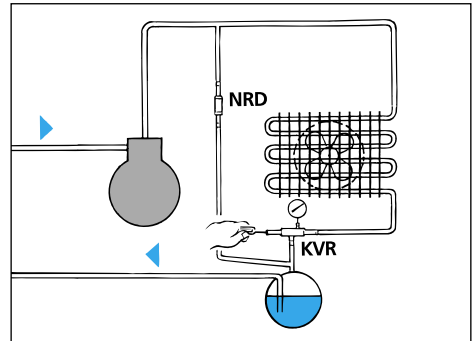

Ak0_0013

KVR + KVD condensing pressure regulator

In refrigeration systems with KVR + KVD, the condensing pressure must first be set with KVR while KVD is closed (setting screw turned back fully counterclockwise).

Then, KVD must be set to a receiver pressure, e.g. about 1 bar lower than condensing pressure. A pressure gauge must be used for this setting which is best made during operation in a winter period.

If the condensing pressure is set during summer operation, one of two procedures can be used:

- 1) In a newly-installed refrigeration system with a KVR/KVD setting of 10 bar as the starting out point, the system can be set by counting the number of turns on the setting screw.
- 2) In an existing refrigeration system, where the KVR/KVD setting is not known, the starting-out point must first be established. The number of turns on the setting screw can then be counted.

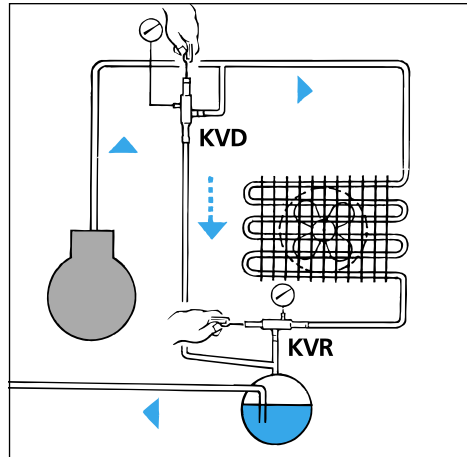

Ak0_0014

Fault location

Symptom	Possible cause	Action
Room temperature too high.	KVP evaporating pressure regulator set too high.	Reduce the setting of the evaporating pressure regulator. The setting should be about 8-10 K lower than required room temperature. Remember to screw on protective cap after final setting.
	Bellows leak in KVP evaporating pressure regulator.	Slowly loosen protective cap. If pressure or traces of refrigerant exist under the cap, there is a leak in the bellows. Replace the valve.
Room temperature too low.	KVP evaporating pressure regulator set too low.	Increase the setting of the evaporating pressure regulator. The setting should be about 8-10 K lower than the required room temperature. Remember to screw on protective cap after final setting.
Suction pressure hunts.	KVP evaporating pressure regulator too large.	Replace evaporating pressure regulator with smaller size. Remember to screw on the protective cap after final setting.
	KVC capacity regulator too large.	Replace capacity regulator with smaller size. Remember to screw on protective cap after final setting.
Suction pressure too high.	KVC capacity regulator defective or set too high.	Replace capacity regulator. Set capacity regulator at lower pressure. Remember to screw on protective cap after final setting.
Condensing pressure too high, air-cooled condensers.	KVR condensing pressure regulator set too high.	Set condensing pressure regulator at correct pressure. Remember to screw on protective cap after final setting.
Condensing pressure too high, water-cooled condensers.	Bellows in KVR condensing pressure regulator might be leaking.	Slowly loosen protective cap. If pressure or traces of refrigerant exist under the cap, there is a leak in the bellows. Replace valve.

Symptom	Possible cause	Action
Crankcase pressure regulator setting drift.	Bellows leak in KVL crankcase pressure regulator.	Slowly loosen protective cap. If pressure or traces of refrigerant exist under the cap, there is a leak in the bellows. Replace the valve.
Compressor discharge pipe too hot.	Probable bellows leak in KVC capacity regulator.	Slowly loosen protective cap. If pressure or traces of refrigerant exist under the cap, there is a leak in the bellows. Replace valve.
	Hot gas quantity too large.	If necessary, set the KVC capacity regulator at lower pressure. An injection valve (e.g. TE2) can be installed in the suction line.
Temperature in receiver too high. No subcooled liquid.	KVD receiver pressure regulator set for too low a pressure.	Set the receiver pressure regulator at a higher pressure. It might also be necessary to increase the setting of the condensing pressure regulator.
	Bellows in KVD receiver pressure regulator might be leaking.	Slowly loosen protective cap. If pressure or traces of refrigerant exist under the cap, there is a leak in the bellows. Replace valve.

Danfoss pressure regulators

Product	Used as	Opens	Pressure range
KVP	Evaporating pressure regulator	on a rise in pressure on the inlet side	0 - 5.5 bar
KVR	Condensing pressure regulator	on a rise in pressure on the inlet side	5 - 17.5 bar
KVL	Crankcase pressure regulator	at a fall in pressure on the outlet side	0.2 - 6 bar
KVC	Capacity regulator	at a fall in pressure on the outlet side	0.2 - 6 bar
CPCE	Capacity regulator	at a fall in pressure on the outlet side	0 - 6 bar
KVD	Receiver pressure regulator	at a fall in pressure on the outlet side	3 - 20 bar
NRD	Differential pressure valve	Begins to open when the pressure drop in the valve is 1.4 bar, and is fully open when the pressure drop is 3 bar.	3 - 20 bar

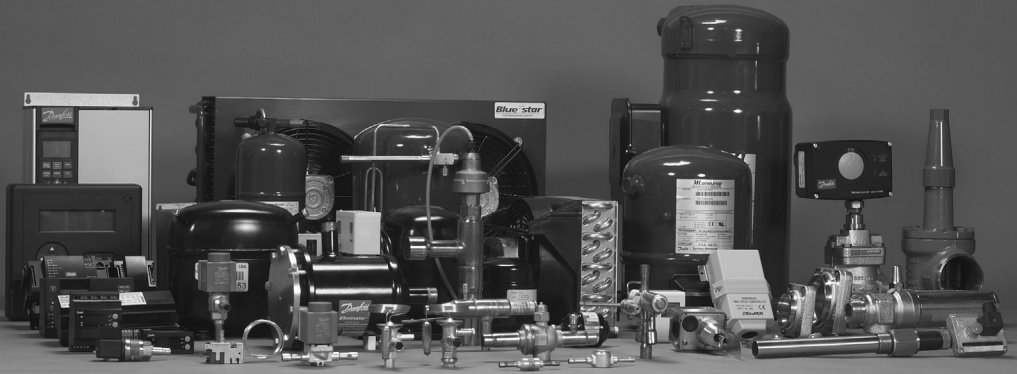

The Danfoss product range for the refrigeration and air conditioning industry

Appliance Controls

General temperature controls for the home appliance industry. The product range comprises CFC-free electromechanical and electronic thermostats for refrigerators and freezers produced to customer specifications as well as service thermostats for all refrigeration and freezing appliances.

Commercial Compressors

Large hermetic reciprocating and scroll compressor technologies for commercial air conditioning and refrigeration. The compressors and condensing units are used in a large array of applications in both businesses. This ranges from water chillers, large packaged air conditioners as well as medium and low temperature refrigeration systems for food storage and processing.

Danfoss Compressors

Hermetic compressors and fan-cooled condensing units for refrigerators, freezers and light commercial applications such as bottle coolers and display counters. Danfoss also produces compressors for heating pump systems as well as 12 and 24 volt compressors for refrigerators and freezers used in mobile applications and solar power. The division has a leading position within energy utilisation, noise filtering and know-how about environment-friendly compressors.

Refrigeration and air conditioning controls

A comprehensive and highly reputed range of self-acting valves, electronic valves and regulators as well as system protectors and line components for the refrigeration and air conditioning market. These products include thermostatic expansion valves, solenoid valves, thermostat and pressure controls, modulation pressure regulators, filter driers, shut-off valves, sight glasses, check valves, non-return valves and water valves. Decentralised electronic systems for full regulation and control of refrigeration applications are also developed and produced at Danfoss.

Industrial Controls

Products and customer specific solutions for industrial monitoring and controls systems based on the principles of pressure and temperature measurement, electrical power and fluid control. Products include a wide range of automatic controls for process control and regulation such as contactors and motor starters, electrically, pneumatically and temperature activated valves as well as temperature and pressure transmitters and switches.