



LG

<http://biz.lgservice.com>

REFRIGERATOR

SERVICE MANUAL

CAUTION
BEFORE SERVICING THE UNIT, READ THE "SAFETY
PRECAUTIONS" IN THIS MANUAL.

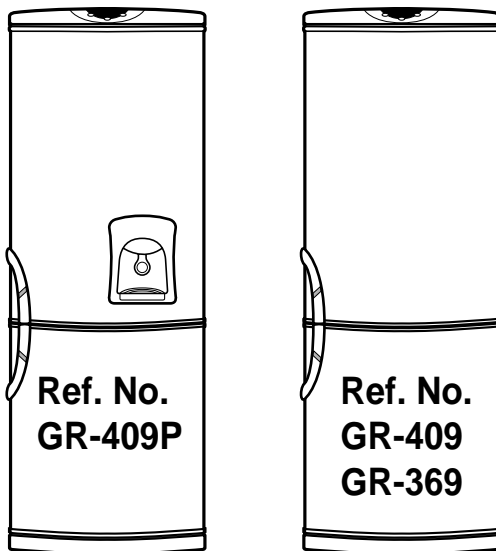

MODEL: GR-409/409P/369

COLOR:

CONTENTS

SAFETY PRECAUTIONS	2
SERVICING PRECAUTIONS	3
SPECIFICATIONS	4
PARTS IDENTIFICATION	5
REPLACEMENT OF DOOR OPENING TYPE	6
DISASSEMBLY	7-8
DOOR.....	7
DOOR SWITCH.....	7
FAN AND FAN MOTOR.....	7
DEF' CONTROL ASM	8
LAMP	8
ADJUSTMENT	9-10
COMPRESSOR.....	9
PTC-STARTER.....	9
OLP (OVER LOAD PROTECTOR)	10
CIRCUIT DIAGRAM	10
TROUBLESHOOTING	11-16
COMPRESSOR AND ELECTRIC COMPONENTS.....	11
PTC AND OLP.....	12
ANOTHER ELECTRIC COMPONENT	13
SERVICE DIAGNOSIS CHART.....	14
REFRIGERATING CYCLE	15-16
MICOM FUNCTION & PCB CIRCUIT EXPLANATION	17-34
EXPLODED VIEW	35-39
REPLACEMENT PARTS LIST	40

SAFETY PRECAUTIONS

Please read the following instructions before servicing your refrigerator.

1. Check the set for electric losses.
2. Unplug prior to servicing to prevent electric shock.
3. Whenever testing with power on, wear rubber gloves to prevent electric shock.
4. If you use any kind of appliance, check regular current, voltage and capacity.
5. Don't touch metal products in the freezer with wet hands. This may cause frostbite.
6. Prevent water from following onto electric elements in the mechanical parts.
7. When standing up after having checked the lower section of the refrigerator with the upper door open, move with care to avoid hitting the upper door.
8. When tilting the set, remove any materials on the set, especially the thin plates(ex. Glass shelf or books.)
9. When servicing the evaporator, wear cotton gloves. This is to prevent injuries from the sharp evaporator fins.
10. Leave the disassembly of the refrigerating cycle to a specialized service center. The gas inside the circuit may pollute the environment.
11. When you discharge the refrigerant, wear the protective safety glasses or goggle for eye safety.
12. When you repair the cycle system in refrigerator, the work area is well ventilated. Especially if the refrigerant is R600a, there are no fire or heat sources. (No smoking)

SERVICING PRECAUTIONS

Features of refrigerant (R600a)

- Achromatic and odor less gas.
- Flammable gas and the ignition (explosion) at 494°C.
- Upper/lower explosion limit: 1.8%~8.4%/Vol.

Features of the R600a refrigerator

- Charging of 60% refrigerant compared with a R134a model
- The suction pressure is below 1bar (abs) during the operation.
- Because of its low suction pressure, the external air may flow in the cycle system when the refrigerant leak, and it causes malfunction in the compressor.
- The displacement of compressor using R600a must be at least 1.7 times larger than that of R134a.
- Any type of dryer is applicable (XH-5, 7, 9).
- The EVAPORATOR or any other cycle part that has welding joint is hidden in the foam. (If not hidden inside, the whole electric parts must be tested with the LEAKAGE TEST according to the IEC Standard.)
- The compressor has label of the refrigerant R600a.
- Only the SVC man must have an access to the system.

Installation place

- Must be well ventilated.
- Must be 20 m³ or larger.
- Must be no-smoking area.
- No ignitable factors must be present.

Utilities

- Refrigerant cylinder (MAX NET 300g)
- Manometer
- Vacuum pump (600 ℓ/min)
- Piercing Clamp
- Quick coupler
- Hoses (5m-1EA, 1m-3EA)
- LOKRING
- Portable Leakage detector (3g/year↓)
- Nitrogen cylinder (for leakage test)
- Concentration gauge

Make sure before Servicing

- Refrigerant
Confirm the refrigerant by checking Name Plate and the label on the compressor, after opening the COVER ASSY, BACK-M/C.
- If the refrigerant is R600a, you must not weld or apply a heat source.

Air Recharging in Compressor

Before refilling the refrigerant, you must perform the test according to Chapter 5 (TROUBLESHOOTING CHART). When the defects are found, you must discharge the residual refrigerant (R600a) in the outdoor. For discharging the refrigerant R600a, break the narrow portion of tube extension by hand or with a pipe cutter as shown in Figure 1. Leave it for 30min in outside to stabilize the pressure with ambient. Then, check the pressure by piercing the dryer part with piercing pliers. If the refrigerant is not completely discharged, let the refrigerator alone for more 30min in outside.

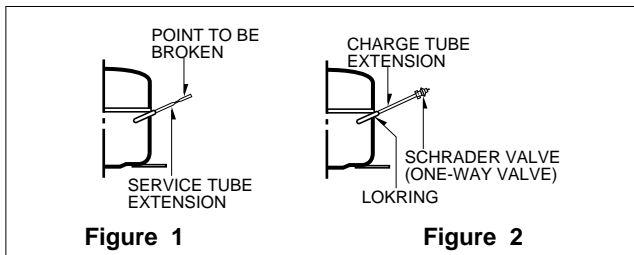

Figure 1

Figure 2

Attach the service tube installed with a Schrader valve (one-way valve) by using the LOKRING (Figure 2). Then, connect the Schrader valve (one-way valve) to the pump that is connected to the discharging hose leading to the outside. When discharging the residual refrigerant, repeat 3 cycle that includes 3min of the pump running->pump off->30sec of the compressor running.

After the refrigerant (R600a) is completely discharged, repair any defective parts and replace the dryer. At any case you must use the LOKRING for connecting or replacing any part in the cycle (No Fire, No Welding). Connect the Schrader valve to pump with the coupler. And then turn the pump on for vacuum state (Figure 3). Let the pump run until the low-pressure gauge indicates the vacuum (gauge pressure 0, absolute pressure -1atm or -760mmHg). Recommended vacuum time is 30 min. Charge the N₂ gas in order to check for leakage from welding points and the LOKRING. If leakages are found, repair the defects and repeat the vacuum process.

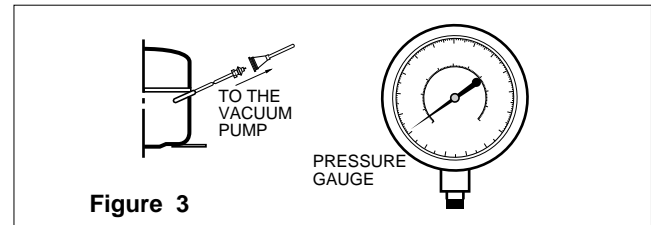

Figure 3

After the system is completely vacuumed, fill it with the refrigerant R600a up to what has been specified at your refrigerator Name Plate. The amount of refrigerant (R600a) must be precisely measured within the error of ±2g by an electron scale (Figure 4).

If you use the manifold connected with both the refrigerant (R600a) cylinder and the vacuum pump simultaneously, make sure the pump valve is closed (Figure 5).

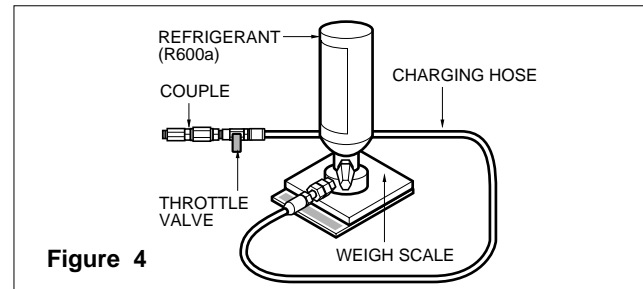

Figure 4

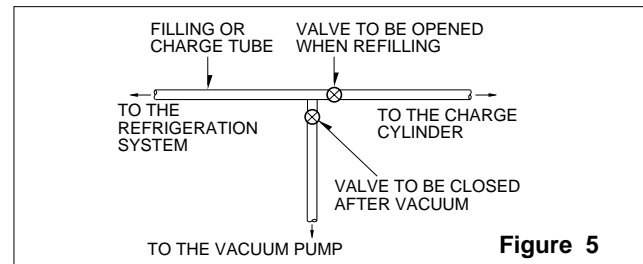

Figure 5

Connect the charging hose (that is connected to the refrigerant (R600a) cylinder) to the Schrader valve installed on the service tube. Then, charge the refrigerant (R600a) by controlling the Throttle valve. When you do so, do not fully open the Throttle valve because it may make damage to the compressor. Gradually charge the refrigerant (R600a) by changing open and close the Throttle Valve (5g at each time). The charging hose must use a one-way valve to prevent the refrigerant reflux. Close the Schrader valve cap after the refrigerant (R600a) is completely recharged.

After you completely recharge the refrigerant (R600a), perform the leakage test by using a portable leakage detector or soapy water. Test the low pressure (suction) parts in compressor off time and high pressure parts in compressor on time. If the leakages are found, restart from the refrigerant (R600a) discharging process and repairs defects of leaks.

After the leakage test, check the temperature of each parts of the cycle. Check with hands if the CONDENSER and the case (HOT-LINE pipe) that is contacted to the door gasket are warm. Confirm that frost is uniform distributed on the surface of the EVAPORATOR.

SPECIFICATIONS

1.Ref. No: GR-409/409P

ITEMS		SPECIFICATIONS	ITEMS	SPECIFICATIONS
DIMENSIONS (mm)		595(W)x626(D)x1880(H)	REFRIGERATOR COMPARTMENT	Transparent Shelf(3 EA)
NET WEIGHT (kg)		77		Vegetable Container(1 EA)
COOLING SYSTEM		Fan Cooling		Vegetable Container Cover(1 EA)
TEMPERATURE CONTROL	REFRIGERATOR	Knob Dial		Fresh Zone Container(1 EA)*
	FREEZER	Button	DOOR POCKET	Dairy Pocket Cover(2 EA)
DEFROSTING SYSTEM		Full Automatic		Egg Tray(2 EA)
		Heater Defrost		Little Pocket(5 EA) 4 or 3 EA
DOOR FINISH		Pre-Coated Metal or Vinyl Coated Metal		Bottle Pocket(1 EA)
OUT CASE		Painted Steel Sheet	FREEZER	Tray Drawer(4 EA)
INNER CASE		ABS	COMPARTMENT	Ice Tray(1 EA)
INSULATION		Polyurethane Foam	COMPRESSOR	PTC Starting Type
DEFROSTING DEVICE		Heater, Sheath & Heater, Cord-L	EVAPORATOR	Fin Tube Type
REFRIGERANT		R600a(60g)	CONDENSER	Side & Wire Condenser
LUBRICATION OIL		FREOL S10(280 cc)	WATER DISPENSER	WATER TANK(1 EA)*

* Optional Parts

2.Ref. No: GR-369

ITEMS		SPECIFICATIONS	ITEMS	SPECIFICATIONS
DIMENSIONS (mm)		595(W)x626(D)x1710(H)	REFRIGERATOR COMPARTMENT	Transparent Shelf(2 EA)
NET WEIGHT (kg)		72		Vegetable Container(1 EA)
COOLING SYSTEM		Fan Cooling		Vegetable Container Cover(1 EA)
TEMPERATURE CONTROL	REFRIGERATOR	Knob Dial		Fresh Zone Container(1 EA)*
	FREEZER	Button	DOOR POCKET	Dairy Pocket Cover(2 EA)
DEFROSTING SYSTEM		Full Automatic		Egg Tray(1 EA)
		Heater Defrost		Little Pocket(3 EA)
DOOR FINISH		Pre-Coated Metal or Vinyl Coated Metal		Bottle Pocket(1 EA)
OUT CASE		Painted Steel Sheet	FREEZER	Tray Drawer(4 EA)
INNER CASE		ABS	COMPARTMENT	Ice Tray(1 EA)
INSULATION		Polyurethane Foam	COMPRESSOR	PTC Starting Type
DEFROSTING DEVICE		Heater, Sheath & Heater, Cord-L	EVAPORATOR	Fin Tube Type
REFRIGERANT		R600a(60g)	CONDENSER	Side & Wire Condenser
LUBRICATION OIL		FREOL S10(280 cc)		

* Optional Parts

PARTS IDENTIFICATION

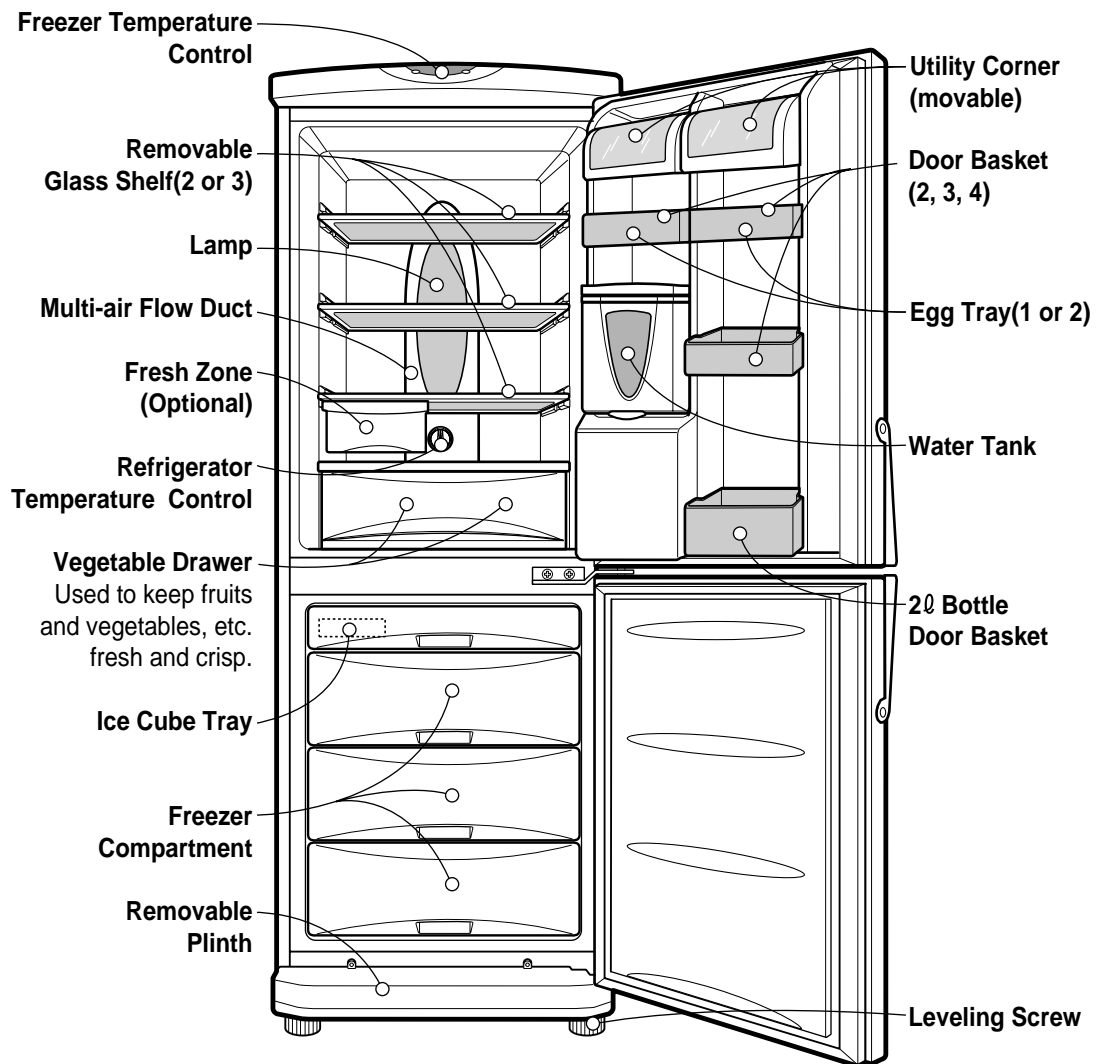

NOTE : This is a basic model. The shape of refrigerator is subject to change.

REPLACEMENT OF DOOR OPENING TYPE

1. PRECAUTION

- 1) Before reversing the door, first of all, you should take out food and accessories like shelves or trays which are not fixed in the refrigerator.
- 2) Use Torque Wrench or Spanner to fix or remove the bolt.
- 3) Don't lay the refrigerator down in working with it, it will cause to get out of order.
- 4) Be careful not to drop the door in disassembling or assembling the freezer or the refrigerator door.

2. HOW TO REVERSE THE DOORS

- 1) Remove SCREWS 3 after removing a CAP 2 from the right part of the refrigerator room HANDLE 1. Remove 2 SCREWS 3 on the bottom part of the refrigerator room HANDLE 1. The freezer room HANDLE 5 may be also separated in the same sequence as in the refrigerator room HANDLE 1.

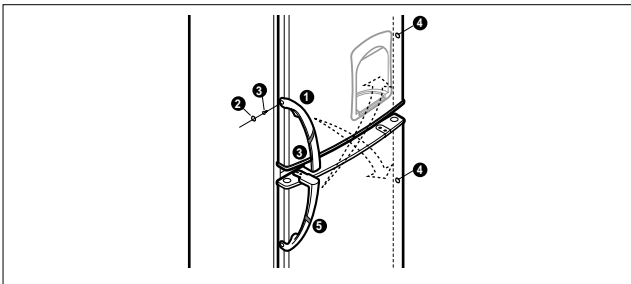

- 2) Remove screw 7 and remove Cover 6 and move Cap Cover 8. And, remove screw 9, Hinge-L 10, and remove pin 11. Remove the Freezer Door 26, and move the position of the cap 12. Move the position of bracket door 13 and screw 14.

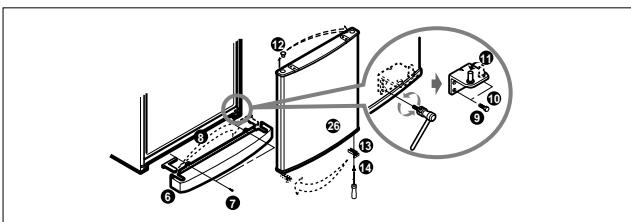

- 3) Remove bolt 15 and remove the Hinge-C 16 and the Fridge Door 17. Move the position of the cap 18. Move the position of bracket door 22 and screw 21.

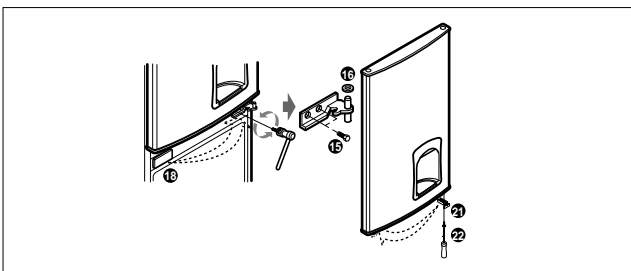

- 4) Move the position of Hinge-U pin 19, and Cap, Top cover 20 Assemble the Fridge Door 17 Assemble Hinge-C 16 and bolt 15 Assemble F-Door 26. Assemble the Hinge-L 10 and bolt 9. Assemble Low Cover 6 and screw 7.

- 5) Install HANDLES 5 installed at the existing freezer room, at the refrigerator room. Adjust the bottom part of HANDLES to the groove and then fasten 2 screws 3 after removing the CAP 27. After bolting SCREWS in the side of the refrigerator room DOOR, press and insert the CAP 2 Insert the CAP 4 to hole which the HANDLE 1 was installed previous. The freezer room HANDLES 1 are assembled in the same manner as above using the existing.

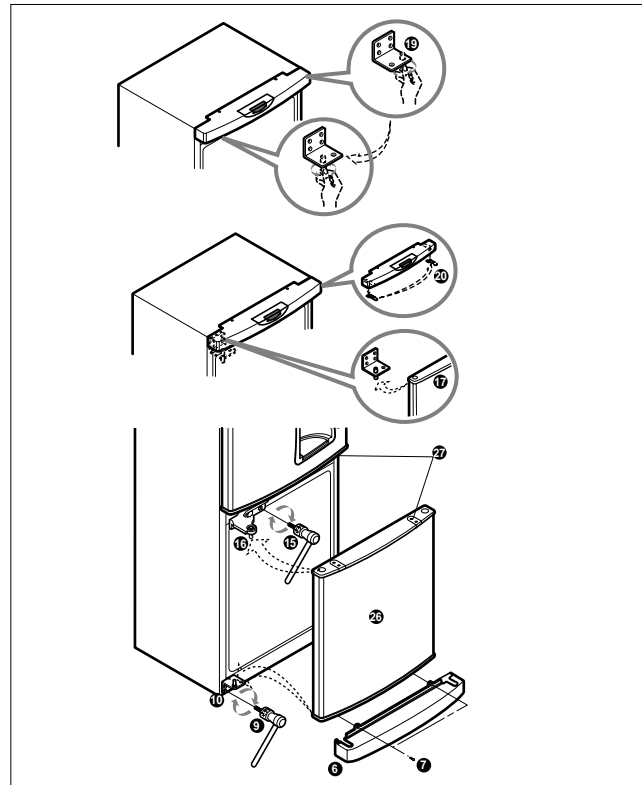

- 6) Stop the groom where the existing HANDLE 1, 5 was installed at by using the CAP 27 removed in the initial installation.

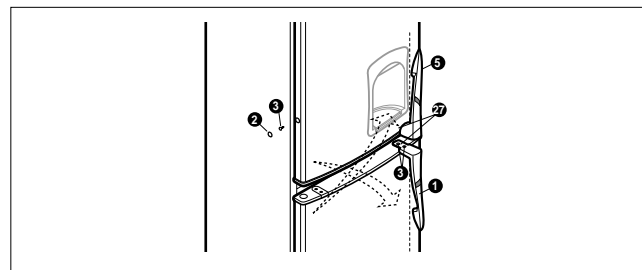

DISASSEMBLY

1 DOOR

● Freezer Door

- 1) Loosen 2 screws and pull the Lower Cover.
- 2) Loosen hexagonal bolts fixing the lower hinge to the body to remove the freezer door only.

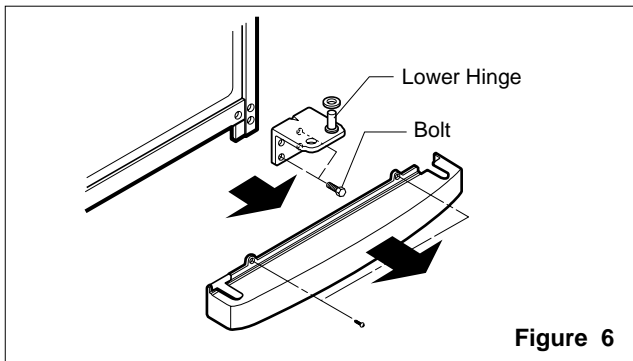

- 3) Pull out the Door Gasket to remove from the Door Foam Assy, F.

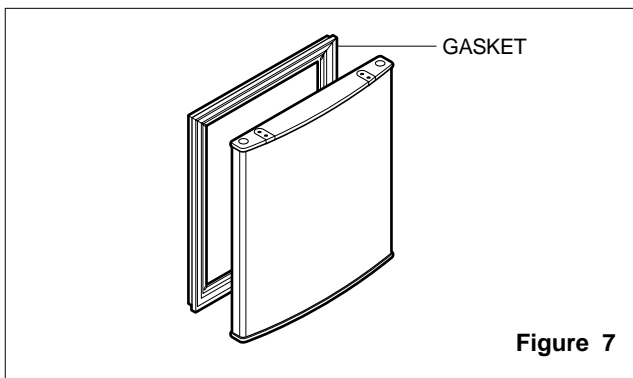

● Refrigerator Door

- 1) Loosen hexagonal bolts fixing the center hinge(Hinge,C) to the body to remove the refrigerator door only.

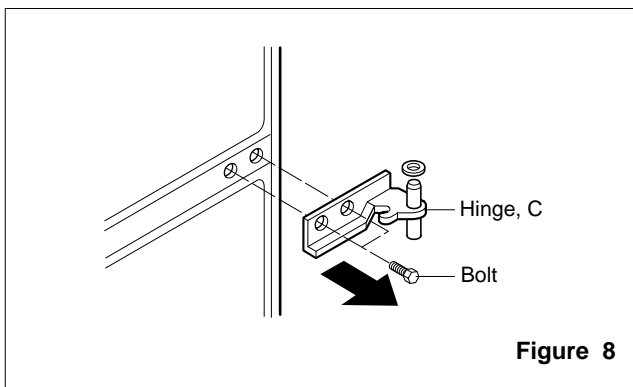

- 2) Pull out the Door Gasket to remove from the Door Foam Assy, R.

2 DOOR SWITCH

- 1) Loosen four screws in upper part and disconnect top cover.
- 2) Disconnect Lead Wire from switch.
- 3) Disengage hook behind the switch by pressing it with hands.

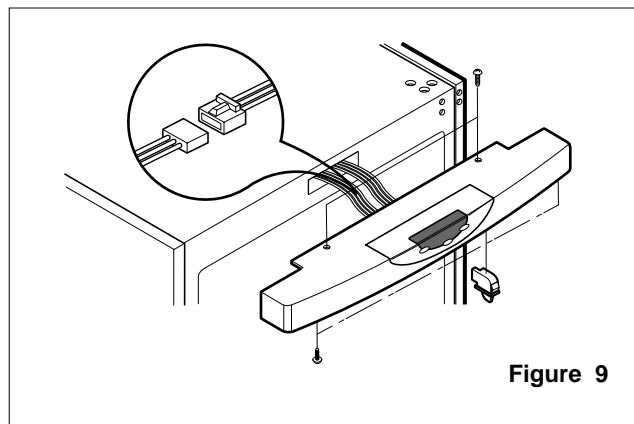

3 REFRIGERATOR ROOM LAMP

- 1) Remove the Cover Lamp, R by pulling with a '-' type driver.
- 2) Remove the Lamp by turning.

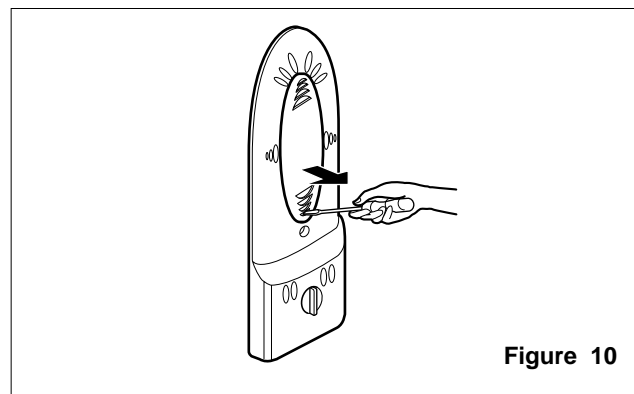

- 3) After removing the lamp, you must check the O-RING, which is made by rubber and prevent electric spark, in the socket.

4 FAN AND FAN MOTOR

- 1) Remove freezer drawers.
- 2) Remove two cap, screws and loosen two screws in Grille Fan.
- 3) Pull out the Grille Fan and Shroud, F.
- 4) Disconnect the housing of lead wire.
- 5) Separate the Fan Assy.
- 6) Lose 2 screw fixed to the Bracket.
- 7) Pull out Shroud, F remove the Fan Motor Assy.
- 8) Separate the Motor Bracket and Rubber.

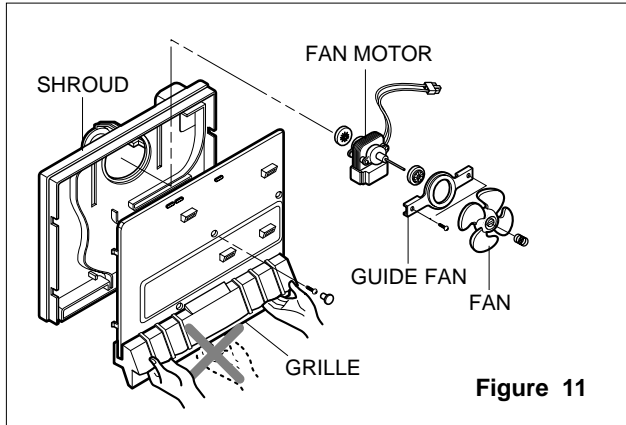

Figure 11

5 DEFROST CONTROL ASSY

Defrost Control Assy consists of Thermistor and Fuse, Melting. Thermistor functions to defrost automatically and it is attached to metal side of the Evaporator and senses temperature. Fuse, Melting is a kind of safety device for preventing overheating of the Heater when defrosting. At the temperature of 72°C, it stops the emission of heat from the Heater.

- 1) Pull out the Shroud, F after removing the Grille.
- 2) Separate the connector connected with the Defrost Control Assy and replace new one.

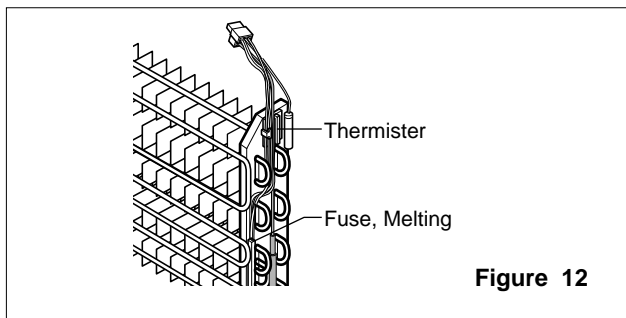

Figure 12

6 DAMPER CONTROL

- 1) Remove the Cover Lamp, R and loosen 2 screw.
- 2) Pull the Control Box, R and separate the lead wire housing.
- 3) Remove the Cover Lamp, R.
- 4) Separate the Insulation Multi Duct and Control Box, R.
- 5) Disassemble the Knob.
- 6) Separate the Damper Control and Control Box, R.
- 7) Separate the Damper Control and Resistor.
- 8) Disconnect the lead wire.

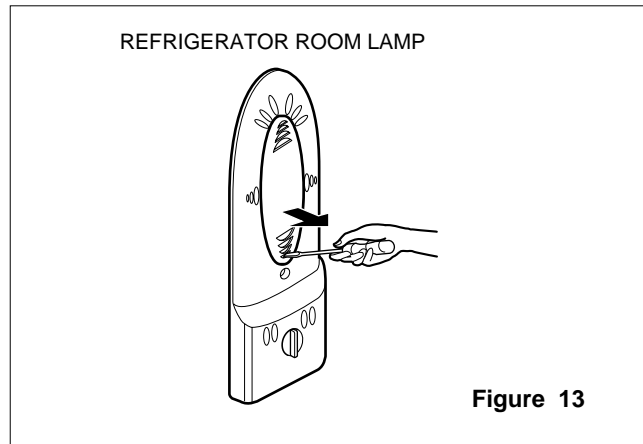

Figure 13

7 HEATER, SHEATH & HEATER, CORD-L

In this refrigerator, Heater, Sheath & Heater, Cord-L are used for defrosting heater. During heating, the temperature of heater rises about 300~350°C. Therefore, be careful not to burn while servicing.

- 1) After removing the Grille and Shroud, separate the Heater, Sheath by disconnecting the connectors.
- 2) Exchanged Heater, Sheath and connected the housing.

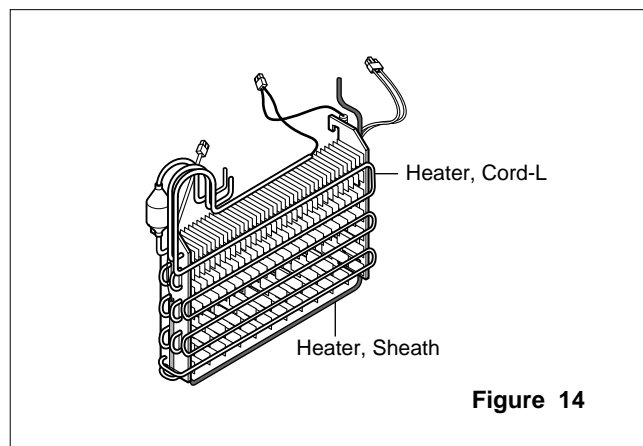

Figure 14

- 3) If the Heater, Cord-L is defected, disconnect the connectors, and separate the Heater, Cord-L with Long Nose.
- 4) Replace and assembly the Heater, Cord-L and connect the connectors.

ADJUSTMENT

1 COMPRESSOR

1) Role

The compressor intakes low temperature and low pressure gas evaporated from Evaporator of the Refrigerator, and condenses this gas to high temperature and high pressure gas, and then plays delivering role to Condenser.

2) Composition

The Compressor is Composed of Compressor Apparatus compressing gas, Compressor Motor moving Compressor Apparatus and Case protecting Compressor Apparatus and Motor. There is Relay Assy (one set of PTC-Starter and Over Load Protector (OLP)) in Compressor. On the other hand, because the Compressor consists of 1/1000mm processing precision components and is sealed after production in absence of dust or humidity, deal and repair with care.

3) Note for Usage

- (1) Be careful not to allow over-voltage and over-current.
- (2) No Strike
If applying forcible power or strike (dropping or careless dealing), poor operation and noise may occur.
- (3) Use proper electric components appropriate to the Compressor.
- (4) Note to Keep Compressor.
If Compressor gets wet in the rain and rust in the pin of Hermetic Terminal, the result may be poor operation and poor contact may cause.
- (5) Be careful that dust, humidity, and flux welding don't inflow in the Compressor inside in replacing the Compressor. Dust, humidity, and flux due to welding which inflows to Cylinder may cause lockage and noise.

2 PTC-STARTER

1) Composition of PTC-Starter

- (1) PTC (Positive Temperature Coefficient) is a no-contact semiconductor starting device which uses ceramic material and this material consists of BaTiO₃.
- (2) The higher the temperature is, the higher becomes the resistance value. These features are used as starting device for the Motor.

2) Role of PTC-Starter

- (1) PTC is attached to Hermetic Compressor used for Refrigerator, Show Case and starts Motor.
- (2) Compressor for household refrigerator applies to single-phase induction Motor.
For normal operation of the single-phase induction motor, in the starting operation flows in both main coil and sub-coil. After the starting is over, the current in subcoil is cut off. The proper features of PTC play all the above roles. So, PTC is used as a motor starting device.

3) PTC-Applied Circuit Diagram

● According to Starting Method for the Motor

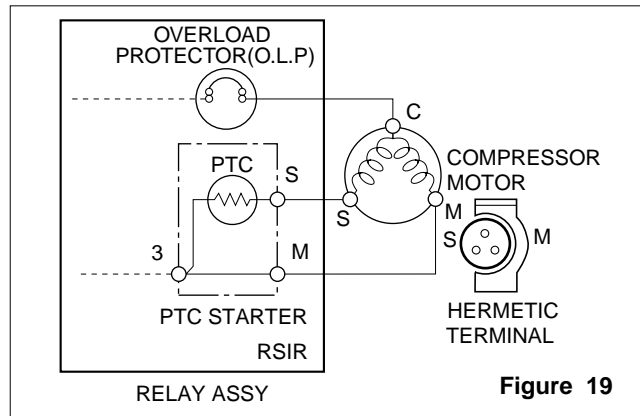

Figure 19

4) Motor Restarting and PTC Cooling

- (1) For restarting after power off during normal Compressor Motor operation, plug the power cord after 5 min. for pressure balance of Refrigerating Cycle and PTC cooling.
- (2) During normal operation of the Compressor Motor, PTC elements generate heat continuously. Therefore, if PTC isn't cooled for a while after the power has been shut off, Motor can't operate again.

5) Relation of PTC-Starter and OLP

- (1) If the power is off during operation of Compressor and the power is on before the PTC is cooled, (instant shut-off within 2 min. or reconnect a power plug due to misconnecting), the PTC isn't cooled and a resistance value grows. As a result, current can't flow to the sub-coil and the Motor can't operate and the OLP operates by flowing over current in only in the main-coil.
- (2) While the OLP repeats on and off operation about 3-5 times, PTC is cooled and Compressor Motor performs normal operation.
If OLP doesn't operate when PTC is not cooled, Compressor Motor is worn away and causes circuit-short and fire. Therefore, use a properly fixed OLP without fail.

6) Note to Use PTC-Starter

- (1) Be careful not to allow over-voltage and over-current.
- (2) No Strike
Don't apply a forcible power or strike.
- (3) Keep apart from any liquid.
If liquid such as oil or water away enter the PTC, PTC materials it may break due to insulation breakdown of the material itself.
- (4) Don't change PTC at your convenience.
Don't disassemble PTC and mold. If the exterior to the PTC-starter is damaged, resistance value is altered and it may cause poor starting of the compressor motor may cause.
- (5) Use a properly fixed PTC.

3 OLP (OVER LOAD PROTECTOR)

1) Definition of OLP

- (1) OLP (OVER LOAD PROTECTOR) is attached to the Hermetic Compressor and protects the Motor by cutting off current in Compressor Motor in case of over-rising temperature by Bimetal in the OLP.
- (2) When over-voltage flows to Compressor motor, the Bimetal works by heating the heater inside the OLP, and the OLP protects Motor by cutting off current which flows to the Compressor Motor.

2) Role of the OLP

- (1) The OLP is attached to the Hermetic Compressor used for the Refrigerator and Show Case and prevents the Motor Coil from being started in the Compressor.
- (2) Do not turn the Adjust Screw of the OLP in any way for normal operation of the OLP.
(Composition and connection Diagram of OLP)

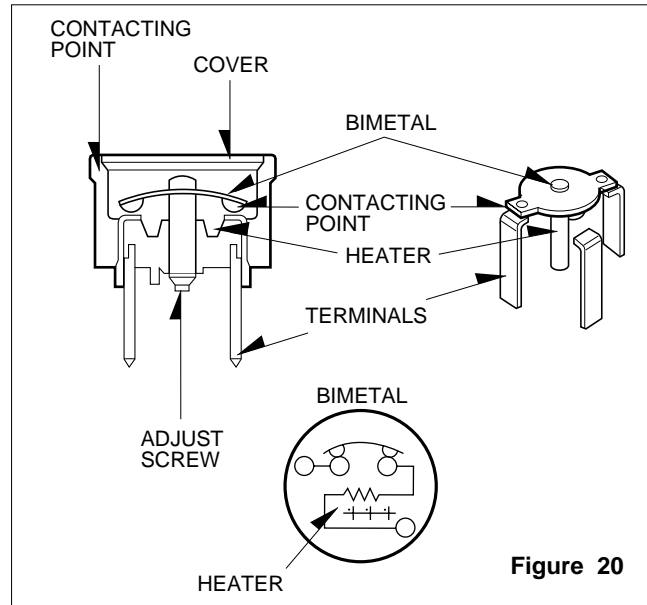
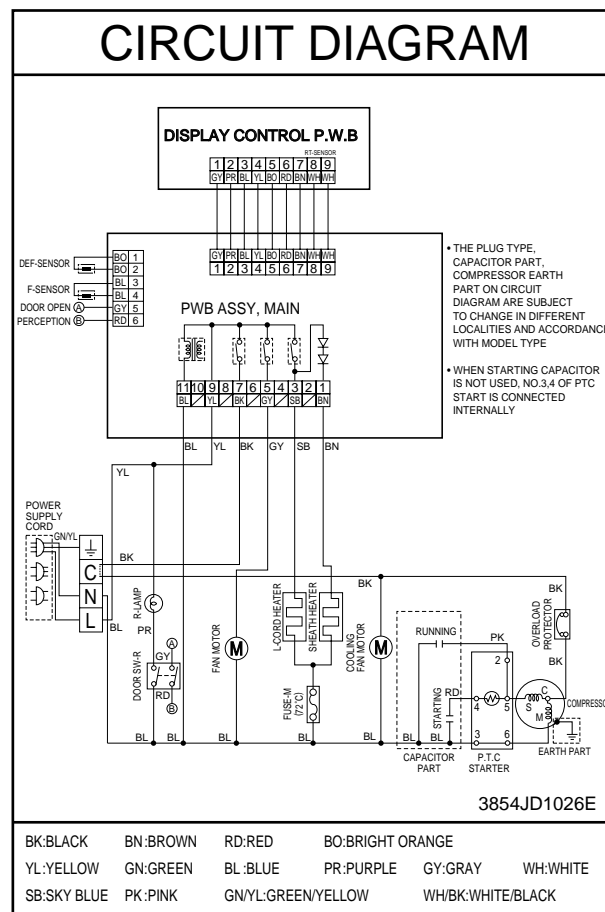

Figure 20

CIRCUIT DIAGRAM



NOTE : 1. This is a basic diagram and specifications vary in different localities.

TROUBLESHOOTING (Mechanical Part)

1 COMPRESSOR AND ELECTRIC COMPONENTS

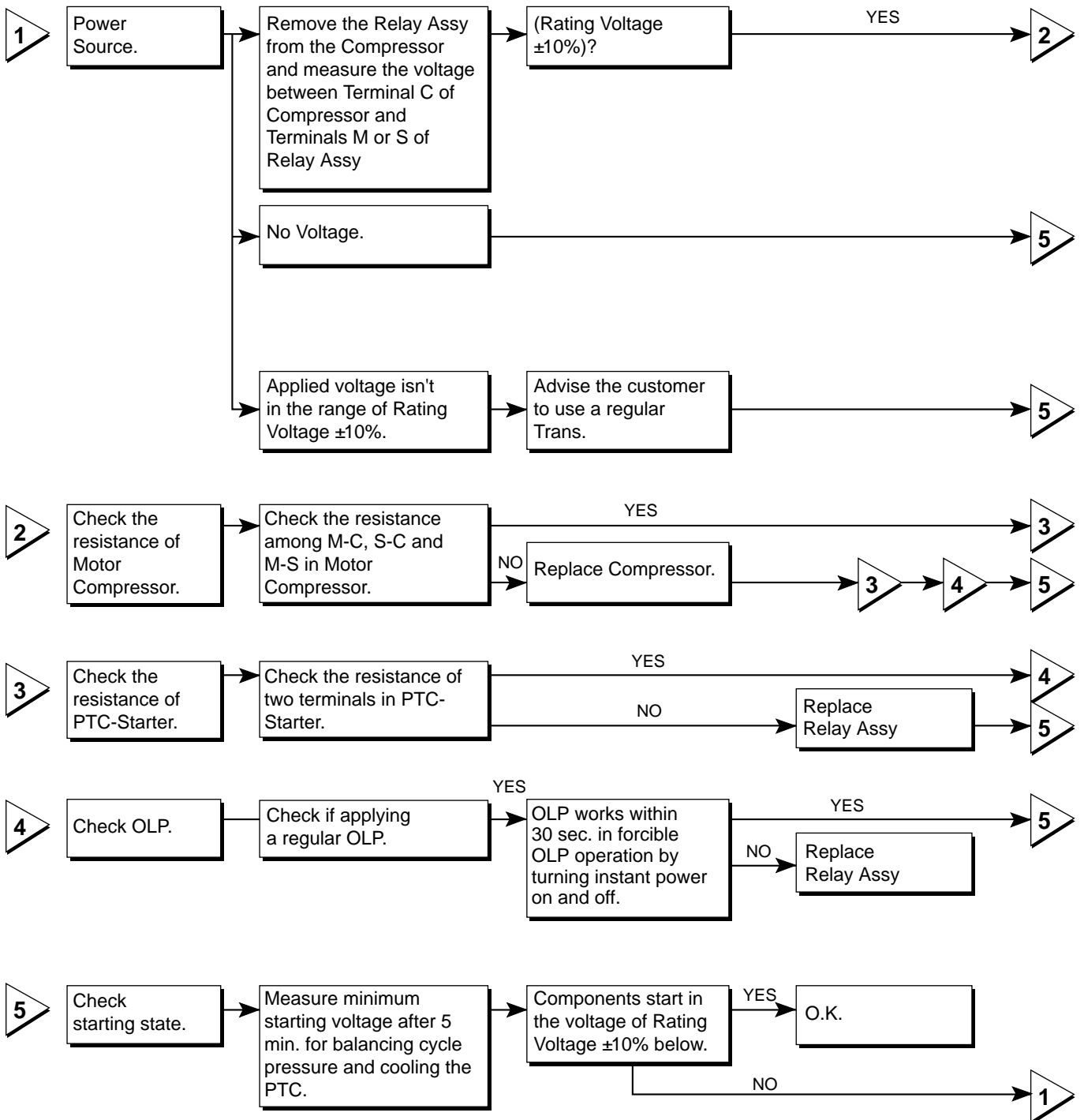

2 RELAY ASSY (PTC AND OLP)

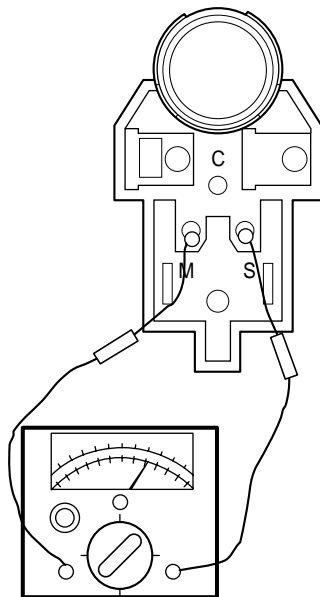
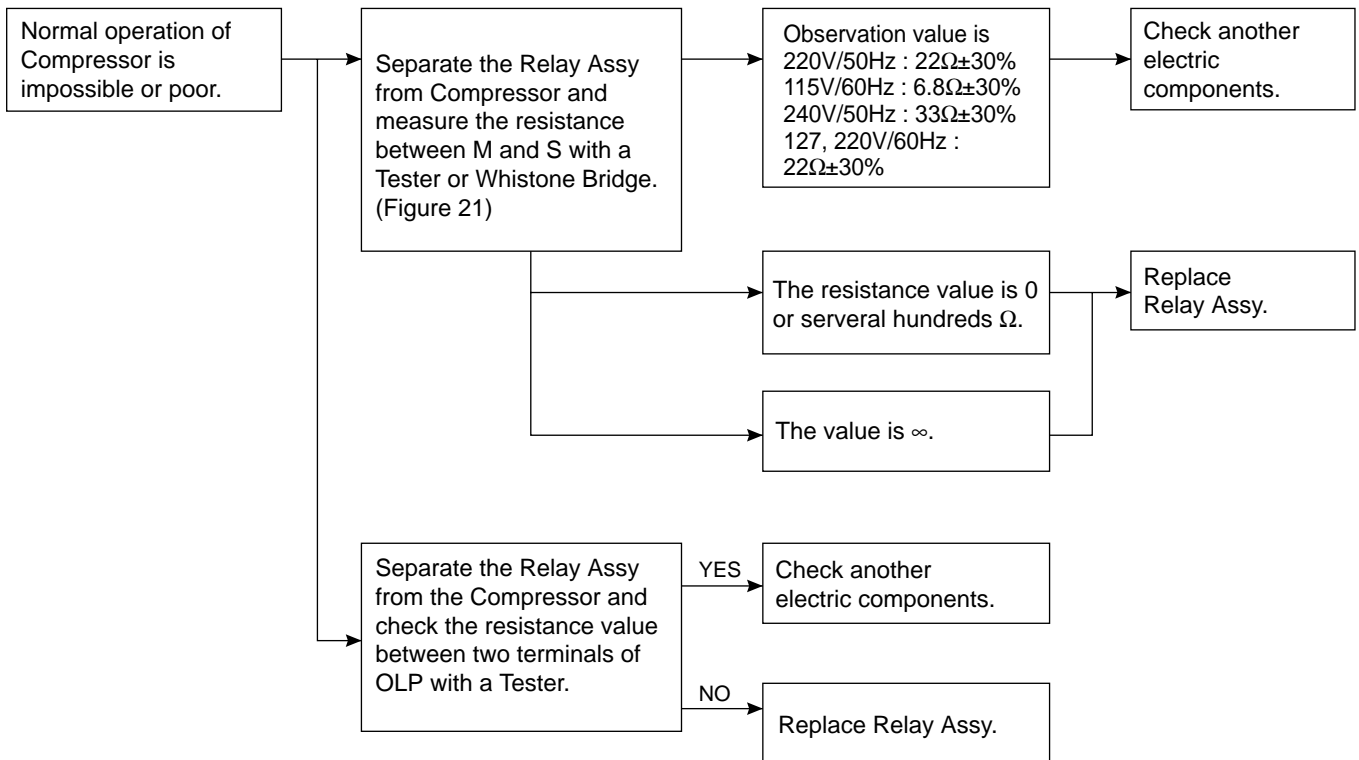

Figure 21

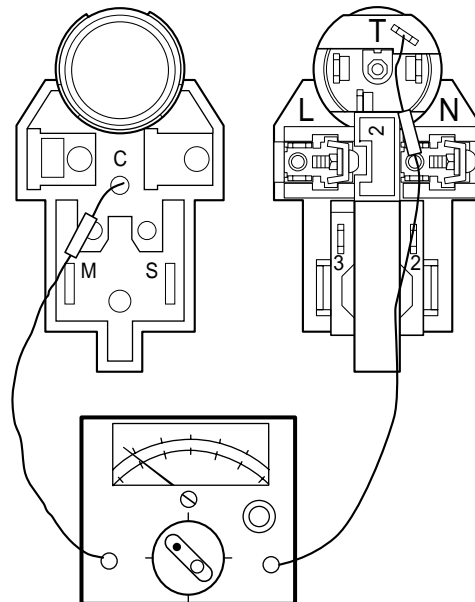
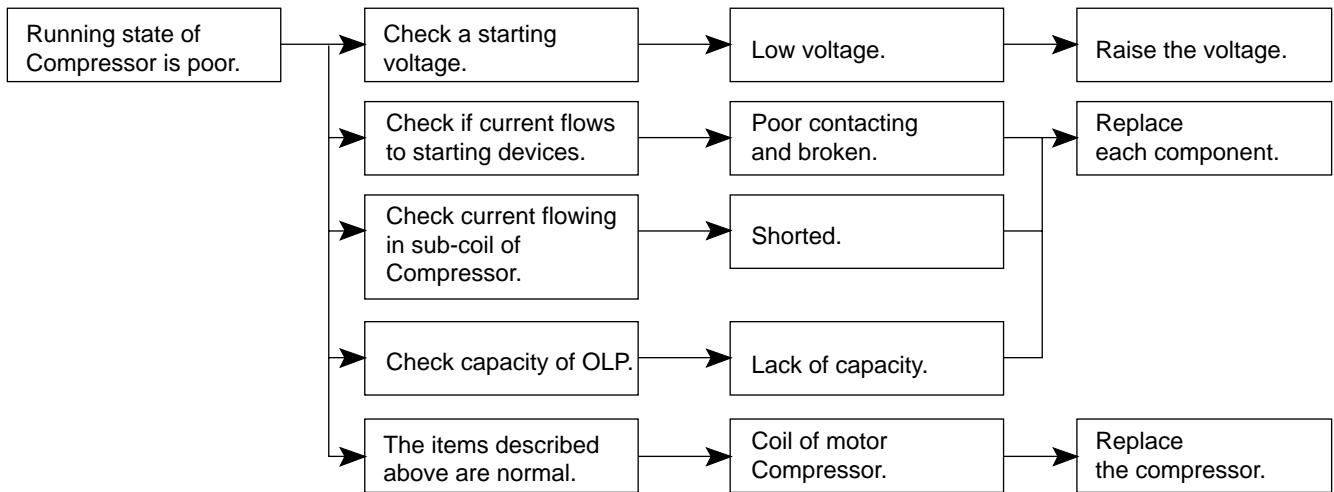
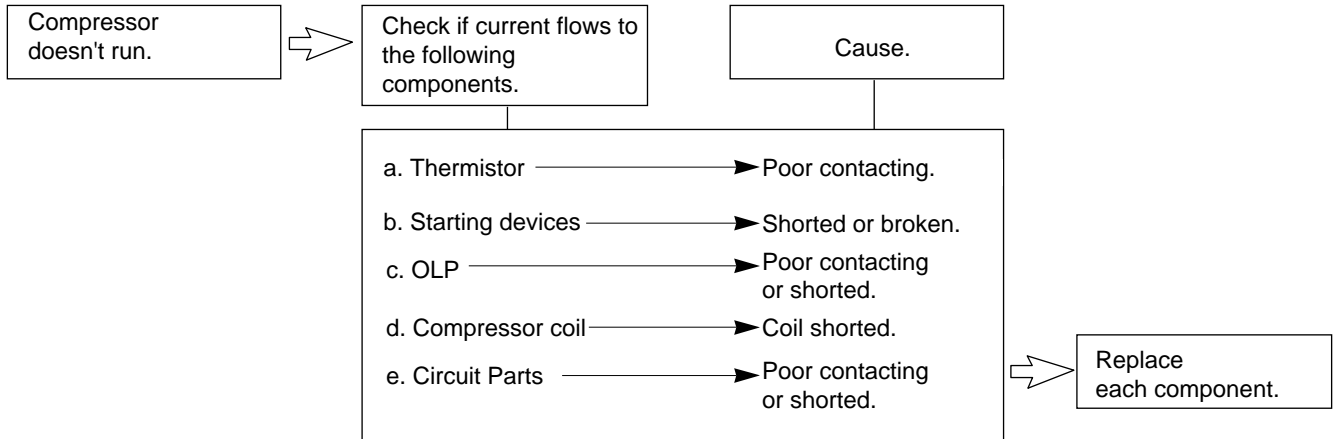

Figure 22

3 ANOTHER ELECTRIC COMPONENTS

▼ Cooling is impossible



▼ Cooling ability is poor

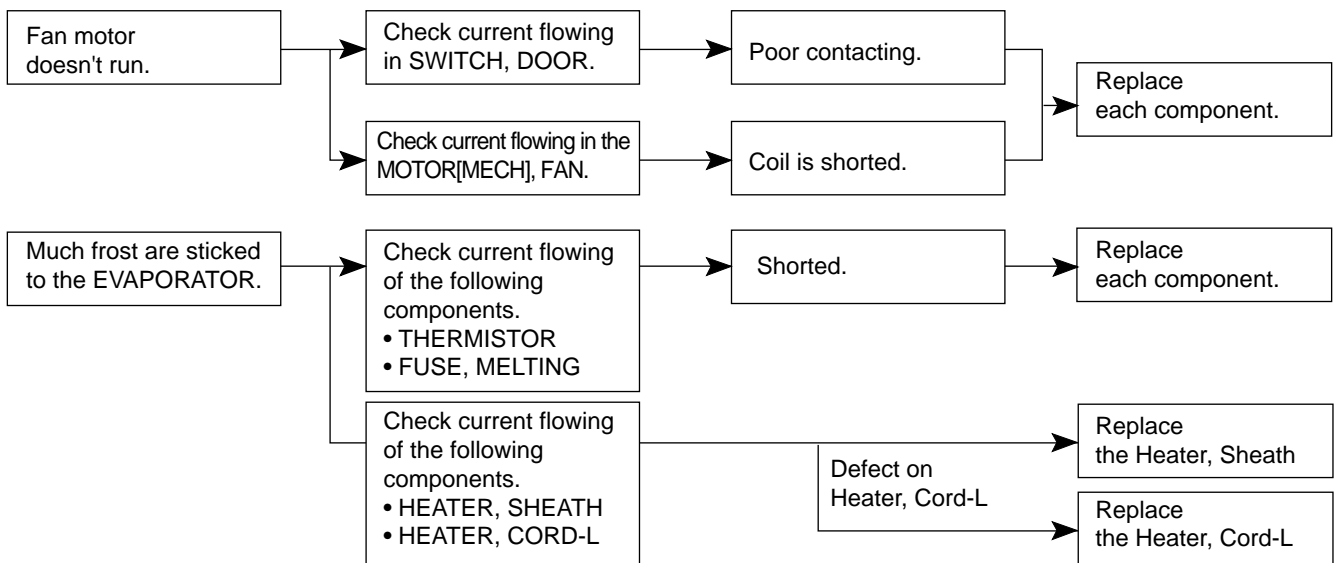

4 SERVICE DIAGNOSIS CHART

COMPLAINT	POINTS TO BE CHECKED	REMEDY
Cooling is impossible.	<ul style="list-style-type: none"> • Is the power cord unplugged from the outlet? • Check if the power switch is set to OFF. • Check if the fuse of power switch is shorted. • Measure the voltage of power outlet. 	<ul style="list-style-type: none"> • Plug to the outlet. • Set the switch to ON. • Replace a regular fuse. • If voltage is low, wire newly.
Cooling ability is poor.	<ul style="list-style-type: none"> • Check if the set is placed close to wall. • Check if the set is placed close to stove, gas cooker and direct rays. • Is the ambient temperature high or the room door closed? • Check if put in is hot. • Did you open the door of the set too often or check if the door is closed up? • Check if the Damper Control is set to "cold-position". 	<ul style="list-style-type: none"> • Place the set with the space of about 10cm. • Place the set apart from these heat appliances. • Make the ambient temperature below. • Put in foods after cooled down. • Don't open the door too often and close it firmly. • Set the control to mid-position.
Foods in the Refrigerator are frozen.	<ul style="list-style-type: none"> • Is foods placed in cooling air outlet? • Check if the control is set to "cold-position". • Is the ambient temperature below 5°C? 	<ul style="list-style-type: none"> • Place foods in high temperature section. (Front Part) • Set the control to "mid-position". • Set the control to "warm-position".
Dew or ice forms in the chamber of the set.	<ul style="list-style-type: none"> • Is liquid food stored? • Check if put in is hot. • Did you open the door of the set too often or check if the door is closed up. 	<ul style="list-style-type: none"> • Seal up liquid foods with wrap. • Put in foods after cooled down. • Don't open the door too often and close it firmly.
Dew forms in the Exterior Case.	<ul style="list-style-type: none"> • Check if ambient temperature and humidity of surrounding air are high. • Is there gap in the door packed? 	<ul style="list-style-type: none"> • Wipe dew with a dry cloth. This occurrence is solved naturally in low temperature and humidity. • Fill up the gap.
Abnormal noise generates.	<ul style="list-style-type: none"> • Are the set positioned in a firm and even place? • Are any unnecessary objects set in the back side of the set? • Check if the Tray Drip is not firmly fixed. • Check if the cover of mechanical room in below and front side is taken out. 	<ul style="list-style-type: none"> • Adjust the Adjust Screw, and position in the firm place. • Remove the objects. • Fix it firmly on the original position. • Place the cover at the original position.
To close the door is not handy.	<ul style="list-style-type: none"> • Check if the door packing is dirty with filth such as juice. • Is the set positioned in a firm and even place? • Is too much food putted in the set? 	<ul style="list-style-type: none"> • Clean the door packing. • Position in the firm place and adjust the Adjust Screw. • Keep foods not to reach the door.
Ice and foods smell unpleasant.	<ul style="list-style-type: none"> • Check if the inside of the set is dirty. • Did you keep smelly foods without wrapping? • It smells of plastic. 	<ul style="list-style-type: none"> • Clean the inside of the set. • Wrap smelly foods. • The new products smells of plastic, but it is eliminated after 1-2 weeks.

● In addition to the items described left, refer to the followings to solve the complaint.

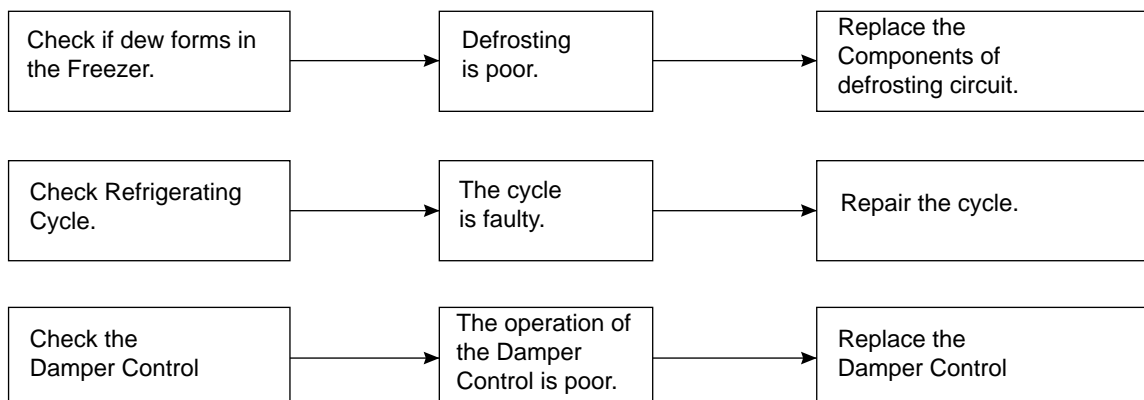

5 REFRIGERATING CYCLE

▼ Troubleshooting Chart

CAUSE		STATE OF THE SET	STATE OF THE EVAPORATOR	TEMPERATURE OF THE COMPRESSOR	REMARKS
LEAKAGE	PARTIAL LEAKAGE	Freezer room and Refrigerator don't cool normally.	Low flowing sound of Refrigerant is heard and frost forms in inlet only	A little high more than ambient temperature.	<ul style="list-style-type: none"> A little Refrigerant discharges. Normal cooling is possible when injecting of Refrigerant the regular amount.
	WHOLE LEAKAGE	Freezer room and Refrigerator don't cool normally.	Flowing sound of Refrigerant is not heard and frost isn't formed.	Equal to ambient temperature.	<ul style="list-style-type: none"> No discharging of Refrigerant. Normal cooling is possible when injecting of Refrigerant the regular amount.
CLOGGED BY DUST	PARTIAL CLOG	Freeze room and Refrigerator don't cool normally.	Flowing sound of Refrigerant is heard and frost forms in inlet only.	A little high more than ambient temperature.	<ul style="list-style-type: none"> Normal discharging of refrigerant. The capillary tube is faulty.
	WHOLE CLOG	Freezer room and Refrigerator don't cool.	Flowing sound of Refrigerant is not heard and frost isn't formed.	Equal to ambient temperature.	<ul style="list-style-type: none"> Normal discharging of Refrigerant.
MOISTURE CLOG		Cooling operation stops periodically.	Flowing sound of Refrigerant is not heard and frost melts.	Low than ambient temperature	<ul style="list-style-type: none"> Cooling operation restarts when heating the inlet of capillary tube.
DEFECTIVE COMPRESSION	COMP-RESSION	Freezer and Refrigerator don't cool.	Low flowing sound of Refrigerant is heard and frost forms in inlet only.	A little high than ambient temperature.	<ul style="list-style-type: none"> The pressure of high pressure part in compressor is low.
	NO COMP-RESSION	No compressing operation.	Flowing sound of Refrigerant is not heard and no frost.	Equal to ambient temperature.	<ul style="list-style-type: none"> No pressure of high pressure part in the compressor.

▼ Leakage Detection

- Observe discharging point of refrigerant which may be in the oil discharging part in the compressor and hole of evaporator.

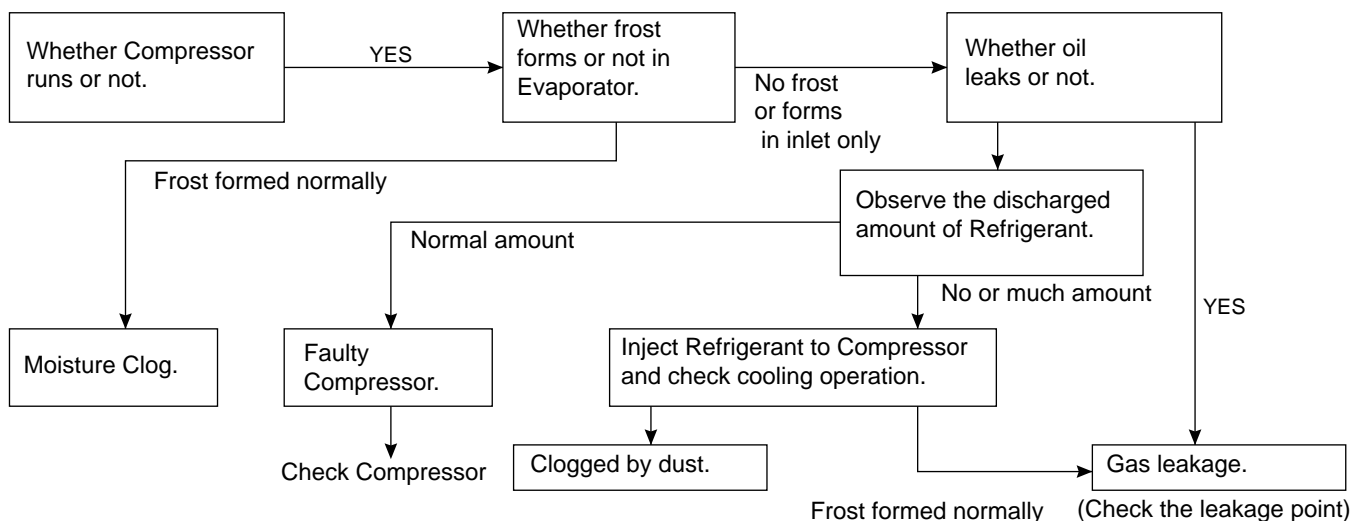

▼ General Control of Refrigerating Cycle

NO.	ITEMS	CONTENTS AND SPECIFICATIONS	REMARKS
1	WELDING ROD	(1) H 30 <ul style="list-style-type: none"> • Chemical Ingredients Ag: 30%, Cu: 27%, Zn: 23%, Cd: 20% • Brazing Temperature: 710~840°C (2) Bcup-2 <ul style="list-style-type: none"> • Chemical Ingredients Cu: About 93% P: 6.8~7.5% The rest: within 0.2% • Brazing Temperature: 735~840°C 	<ul style="list-style-type: none"> • Recommend H34 containing 34% Ag in the Service Center.
2	FLUX	<ul style="list-style-type: none"> • Ingredients and how to make Borax 30% Borax 35% Fluoridation kalium: 35% Water: 4% Mix the above ingredients and boil until they are transformed into liquid. 	<ul style="list-style-type: none"> • Make amount for only day. Holding period: 1 day • Close the cover of container to prevent dust putting in the FLUX. • Keep it in a stainless steel container.
3	LOKRING (Figure 23,24)	(1) Both of the tube is inserted up to the stop. (2) Both of the LOKRING is pushed up to the stop (3) The bending point is not too close to the joint ending. (4) During the assembly it is important that both ends remain completely within the joint.	<ul style="list-style-type: none"> • For a hermetically sealed metal/metal connection, the tube ends have to be clean. • LOKPREP is distributed all of out-surface of the tube ends.
4	DRIER ASM	(1) Assemble the drier within 30min. after unpacking. (2) Keep the unpacked drier at the temperature of 80~100°C.	<ul style="list-style-type: none"> • Don't keep the drier in a outdoors because humidity damages to it.
5	VACUUM	(1) When measuring with pirant Vacuum gauge the charging M/C, vacuum degree is within 1 Torr. (2) If the vacuum degree of the cycle inside is 10 Torr. below for low pressure and 20 Torr. for high pressure, it says no vacuum leakage state. (3) Vacuum degree of vacuum pump must be 0.05 Torr. below after 5 min. (4) Vacuum degree must be same to the value described item (2) above for more than 20 min.	<ul style="list-style-type: none"> • Apply M/C Vacuum Gauge without fail. • Perform vacuum operation until a proper vacuum degree is built up. • If a proper vacuum degree isn't built up, check the leakage from the Cycle Pipe line part and Quick Coupler Connecting part.
6	DRY AND AIR NITROGEN GAS	(1) The pressure of dry air must be more than 12~16kg/cm ² (2) Temperature must be more than -20~-70°C. (3) Keep the pressure at 12~6kg/cm ² also when substituting dry air for Nitrogen Gas.	
7	NIPPLE AND COUPLER	(1) Check if gas leaks with soapy water. (2) Replace Quick Coupler in case of leakage.	<ul style="list-style-type: none"> • Check if gas leaks from joint of the Coupler.
8	PIPE	<ul style="list-style-type: none"> • Put all Joint Pipes in a clean box and cover tightly with the lid so that dust or humidity is not inserted. 	

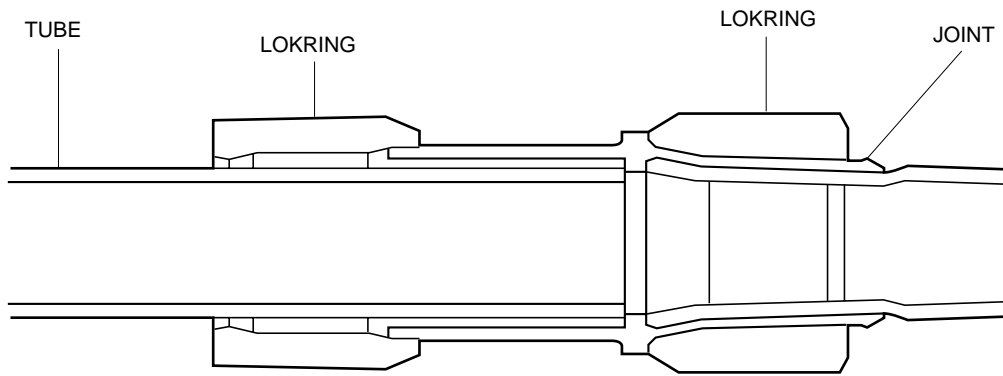
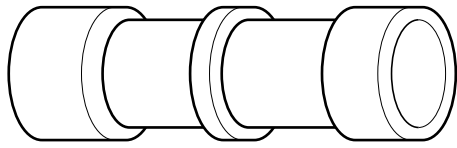

Figure 23. LOKRING

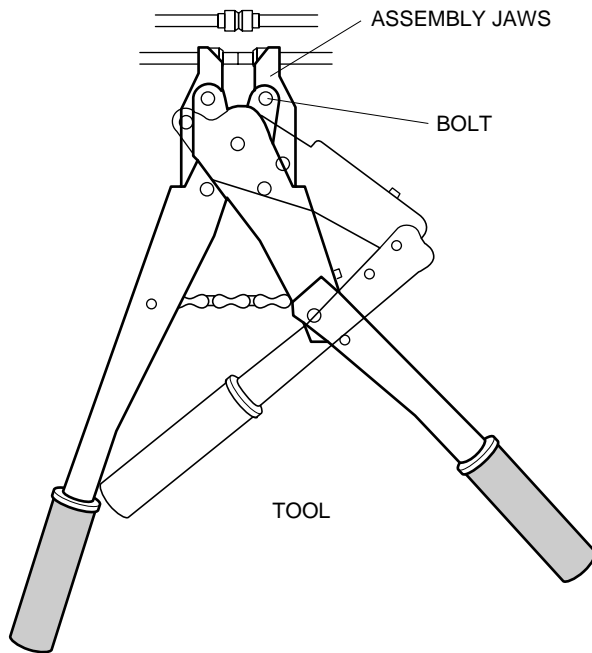

Figure 24. LOKRING TOOL

MICOM FUNCTION & PCB CIRCUIT EXPLANATION

This description is made for GR-349, 389SQ. Please refer to overall PCB circuits for other models.

1 FUNCTION EXPOSITION

1) FUNCTION

- (1) The refrigerator starts from optimum condition when electric power is first on. But the operation condition changes "Mid" → "Mid/Max" → "Max" → "Min" → "Min/Mid" → "Mid" whenever pressing the FREEZE TEMP button.
- (2) It returns to "Mid" conditions if power off and on again.

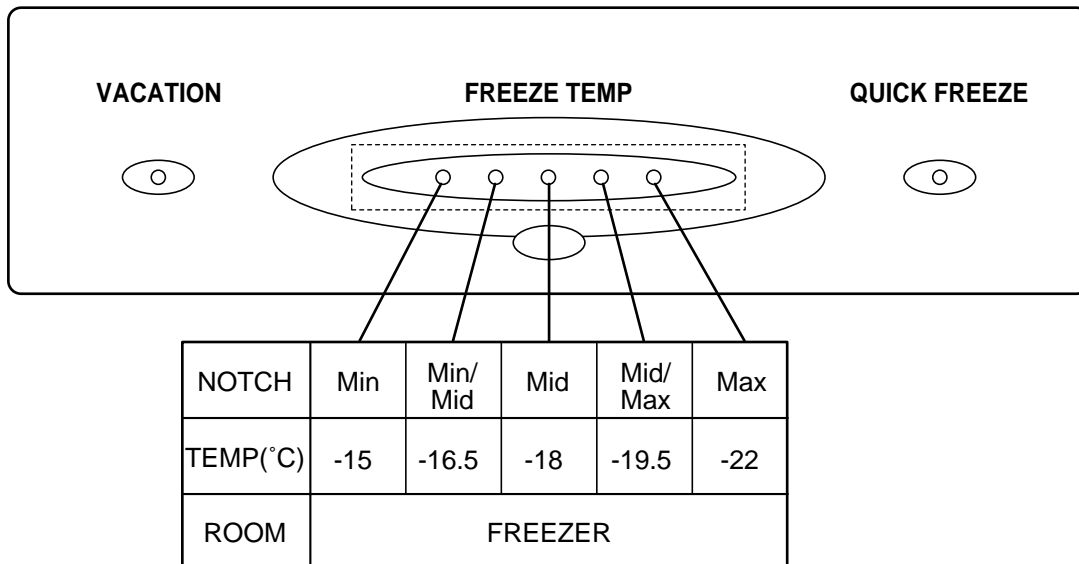

2) QUICK FREEZER

- (1) Function to raise the freezing speed by operating the COMP successively. As pressing the QUICK FREEZE button, the QUICK FREEZE LED is displayed. Then after 3 hours' successive operation of COMP, the QUICK FREEZING function will be released.
- (2) Defrosting During the QUICK FREEZING operates as follow.
When the QUICK FREEZING time is below 90 minutes, defrost and then operate the QUICK FREEZING for the remaining time. When the QUICK FREEZING time is over 90 minutes, defrost and then operate the QUICK FREEZING for 2 hours
- (3) If QUICK FREEZE button is pressed during defrosting, the QUICK FREEZE LED is lit up. But the QUICK FREEZING operates for 3 hours after 7 minutes from the end of defrosting.
- (4) If VACATION button is pressed during the QUICK FREEZING, the QUICK FREEZING LED function is released.
- (5) If power off during the QUICK FREEZING and power on again, the QUICK FREEZING function is released.

3) VACATION FUNCTION

- (1) Function for Energy Saving. As pressing the VACATION button, the VACATION LED is displayed and this function is operated.
- (2) Freezer Compartment is not kept by compressor at the notch displayed but at $-13^{\circ}\text{C} \pm$ differential.
- (3) Defrosting and Fan control is same as normal operation.
- (4) If QUICK FREEZE button is pressed during the VACATION FUNCTION, VACATION FUNCTION is released.
- (5) If power off during the VACATION FUNCTION and power on again, the VACATION FUNCTION is released.

4) DOOR OPENING ALARM

- (1) When the REFRIGERATOR DOOR is opened and won't be closed after 1 minute from the its opened, BUZZER sounds to notify it.
- (2) At first, BUZZER sounds three times at each intervals of 0.5 second. Then makes a 0.5 second ON/OFF alarm three times at intervals of 30 seconds.
- (3) If the REFRIGERATOR door closed during ALARM, it is released.

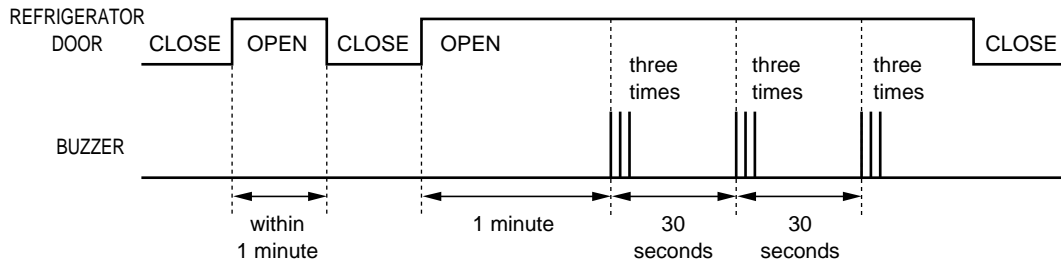

5) DISPLAY BUTTON RING

- (1) If display function button(FREEZE TEMP, QUICK FREEZE, VACATION) of the front of the TOP COVER is pushed, BUZZER rings with "DING~ DONG~"(See the BUZZER OPERATION CHECK)

6) DEFROSTING

- (1) If the accumulated time for the operation of the COMPRESSOR is meet with 7 hours, the DEFROSTING HEATER is started.
- (2) The first defrosting is performed at 4 hours(compressor ON) later since the power is on.
- (3) If DEFROST SENSOR is over 7°C during DEFROSTING, end the operation of DEFROSTING with DEFROSTING HEATER paused, And after 7 minutes, the operation for the freezing is started.
But, if DEFROST SENSOR is not reach to 7°C after 2 hours' operation of the defrosting heater, it represents a defrosting trouble.(See the TROUBLE REPRESENTING FUNCTION)
- (4) If DEFROST SENSOR is short or open, defrosting is not performed.

7) ORDERLY OPERATION OF ELECTRIC PARTS

To avoid NOISE and DAMAGE, the items containing an electric parts such as COMP, DEFROSTING HEATER and FAN MOTOR operate in order as follows.

	OPERATION STATE	OPERATION ORDER
WHEN PLUGGED AT FIRST	WHEN DEFROST SENSOR TEMPERATURE IS OVER 7°C. (WHEN PURCHASING OR MOVING)	POWER ON → after 0.5 sec. → COMP ON → after 0.5 sec. → FAN ON
	WHEN DEFROST SENSOR TEMPERATURE IS BELOW 7°C. (WHEN POWER FAILURE OR SERVICING)	POWER ON → after 0.5 sec. → DEFROSTING HEATER ON → after 10 sec. → DEFROSTING HEATER ON after 0.5 sec. → COMP ON → after 0.5 sec. → FAN ON
	WHEN RETURNING TO NORMAL STATE FROM TEST MODE	All Elec. Parts OFF → after 7 min. → COMP ON → after 0.5 sec. → FAN ON

8) SELF-TEST

- (1) Function to make service easy in case of occurring a trouble in the product.
- (2) When occurring a trouble, if the button is pushed, but the function could not operate.
- (3) If a trouble release during the representation of trouble, a refrigerator performs the normal function(RESET).
- (4) To represent a ERROR CODE, it use FREEZE TEMP LEDs on TOP COVER. If ERROR occurs, the other LEDs except ERROR CODE LEDs are all off.

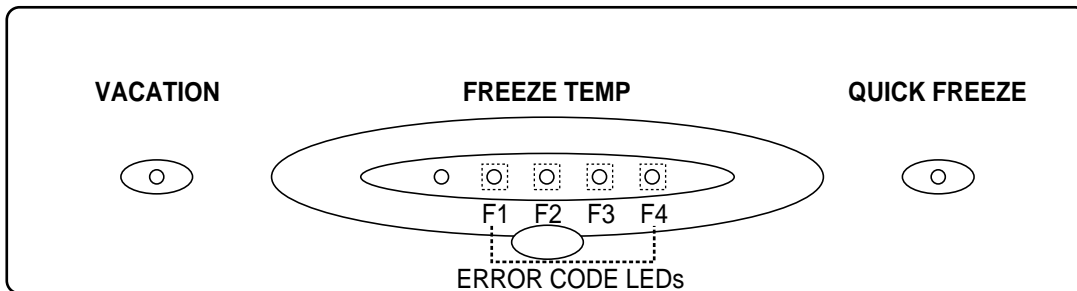

O : OPERATE NORMAL : ON
 : OFF

NO.	ITEMS	ERROR CODE LEDs F1 F2 F3 F4	DESCRIPTION	OPERATION IN TROUBLE'S OCCURRING		
				COMP	FAN	DEFROST HEATER
1	FREEZER SENSOR abnormal		FREEZER SENSOR open or short.	15 minutes On/ 15 minutes Off	O	O
2	DEFROST SENSOR abnormal		DEFROST SENSOR open or short.	O	O	No defrosting
3	DEFROSTING FUNCTION is abnormal		DEFROST HEATER, TEMP. FUSE open or disconnection (Displayed after at least 4 hours from the trouble's occurring.)	O	O	O
4	RT-SENSOR abnormal	NOTE 1)	Room Temperature SENSOR open or short	O	O	O

* NOTE 1) If one second pass after pressing the QUICK FREEZE and FREEZE TEMP buttons together in normal operation, operates as follow.

RT-SENSOR If normal, LEDs on the TOP COVER is all on.
 If abnormal, LEDs are all on except VACATION LED.

9) FUNCTION TEST

- (1) Function to check the testing function of PCB and refrigerator and to find where the trouble.
- (2) The test switch is on the MAIN PCB of refrigerator.
TEST FUNCTION is released and RESET after MAX. 2hours regardless of TEST MODE.
- (3) If the buttons on TOP COVER is pushed during TEST MODE, Function is not operated and only BUZZER ring with "DING~ DONG~"
- (4) After the end of TEST MODE, pull out the power cord and plug it in again(RESET).
- (5) If a ERROR occurs during the TEST MODE, TEST FUNCTION is released and DISPLAY LEDs represent ERROR CODE.
- (6) If the TEST swithch is pushed during ERROR CODE, TEST FUNCTION is not operated.

MODE	OPERATION	CONTENTS	REMARKS
TEST 1	Press TEST button once.	1. COMP OPERATES SUCCESSIVELY. 2. FAN OPERATES SUCCESSIVELY. 3. DEFROSTING HEATER OFF 4. ALL DISPLAY LEDS ON.	
TEST 2	Press TEST button once in the state of TEST MODE 1.	1. COMP OFF. 2. FAN OFF. 3. DEFROST HEATER ON. 4. ALL THE DISPLAY LEDS OFF EXCEPT QUICK FREEZE AND VACATION LEDS.	If DEFROST HEATER is over 7°C, it returns to the NORMAL STATE.
NORMAL STATE	Press TEST button once in the state of TEST MODE 2.	Return to the initial condition. (RESET)	Comp starts after 7 minutes.

- **LED Check Function** : Press the QUICK FREEZE and FREEZE TEMP buttons at the same time. After 1 sec., all the LEDs of the DISPLAY are ON simultaneously. If release the BUTTON, return to the previous condition.

2 FUNCTION DESCRIPTION

1) ELECTRIC CIRCUITS

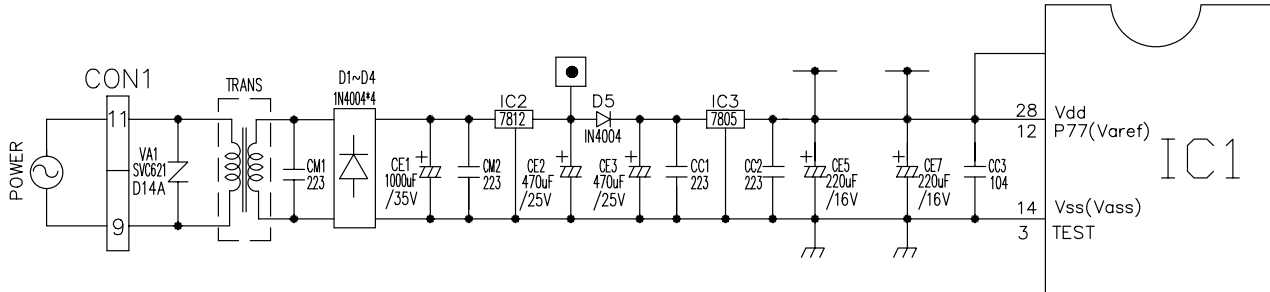

TRANS secondary side is composed of electric power circuits for RELAY driving electricity (12Vdc) and for supplying electricity to MICOM and IC (5Vdc). The voltage in each part is as follows.

PARTS	both ends of VA1	both ends of CM1	both ends of CM2	both ends of CE2	both ends of CC2
VOLTAGE	230Vac	14Vac	17Vdc	12Vdc	5Vdc

VA1 is the part to protect over voltage and noise. When more than 385V is applied, the thermal-fuse(130°C cut-off, local option) in a first part of TRANS is cut so that the elements in the secondary side of TRANS are protected.

2) OSCILLATION CIRCUIT

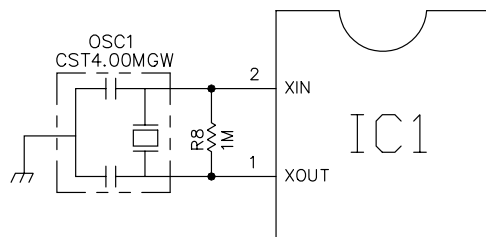

CIRCUIT for occurring CLOCK which motivates the internal local element of IC1 to transmit and receive an information and BASIC TIME for calculating time. Use a proper form for OSC 1. Because in case that SPECIFICATION is changed, the calculated time in IC1 is changed or IC1 isn't able to operate.

3) RESET CIRCUIT

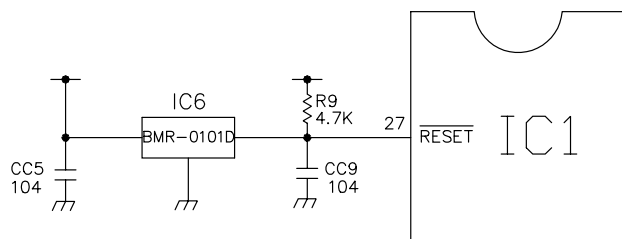

All the internal parts of MICOM(IC1) return to the initial condition when the early power ON or apply power again in MICOM after temporary power failure. As a result, all the functions operate according to the early condition. At the early period of power ON the "LOW" voltage is applied in the RESET terminal of MICOM for the fixed time. The RESET terminal is 5V during the general operation.

4) LOAD/BUZZER OPERATION, DOOR OPENING SENSING CIRCUIT

(1) LOAD OPERATION CHECK

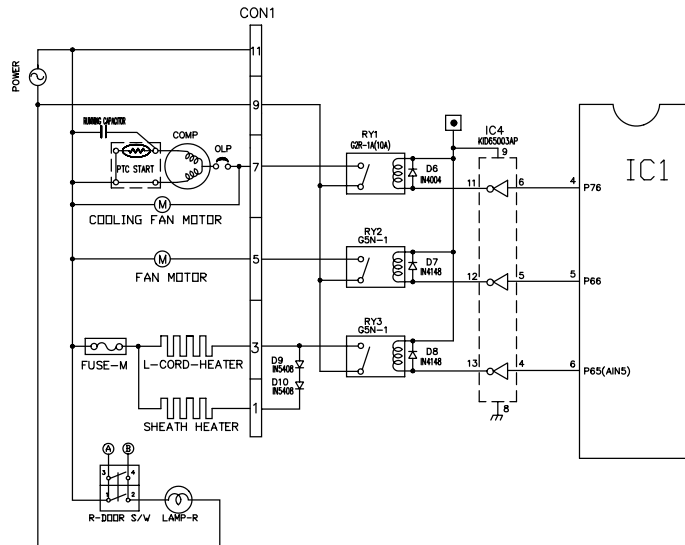

KIND OF LOAD		COMP, COMP COOLING FAN	FAN MOTOR	DEFROSTING HEATER
MEASURING POINT (IC4)		No.11	No.12	No.13
STATE	ON	below 1V		
	OFF	12V		

- If the DOOR-R is opened during FAN MOTOR is operated, FAN MOTOR is stopped immediately.
- The (A), (B) of DOOR S/W-R is connected DOOR OPEN DETECTION CIRCUIT as follow.
- If the DOOR-R is opened or closed, then the DOOR S/W-R is ON/OFF, and the LAMP-R is ON/OFF, and at the same time, S/W of the (A), (B) of DOOR S/W-R for detection of DOOR-R open is ON/OFF.

(2) DOOR OPENING PERCEPTION CHECK

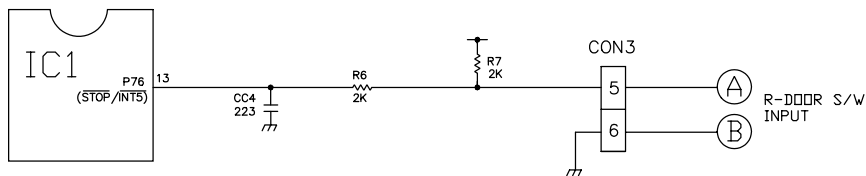

*NOTICE: If you would change DOOR S/W-R, must use the component of right PART NUMBER. Because there is a similar type DOOR S/W-R of NOT MICOM MODEL, it's logic of the A, B of DOOR S/W-R is reversed.

MEASURING POINT	NO.13 OF IC 1 (MICOM)
REFRIGERATOR DOOR	
CLOSE	5V(S/W of (A), (B) is OFF state)
OPEN	0V(S/W of (A), (B) is ON state)

- Even though LAMP-R is operated a normal ON/OFF according to DOOR S/W-R, but the MICOM couldn't detect a DOOR-R opened or closed of lead wire of the (A), (B) is abnormal or S/W of the (A), (B) of DOOR S/W-R is abnormal.
- When DOOR-R open isn't detected : Even though DOOR-R is opened, FAN MOTOR couldn't stop.
When DOOR-R close isn't detected : Even though DOOR-R is closed, BUZZER sounds a DOOR OPEN ALARM.
check a lead wire of the (A), (B) and DOOR S/W-R.

(3)BUZZER OPERATION CHECK

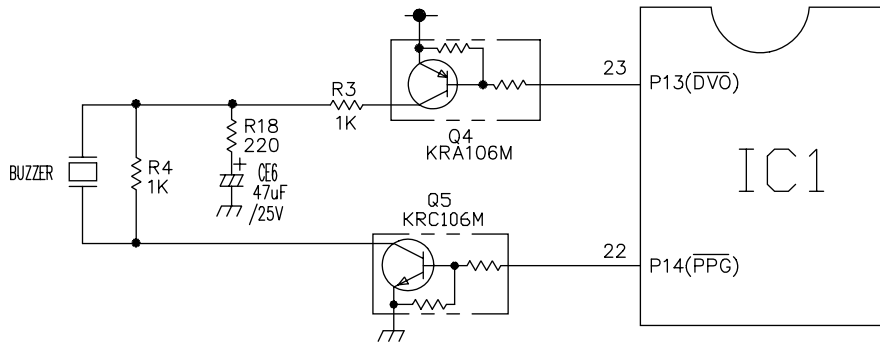

CONDITIONS MEASURING POINT	DISPLAY FUNCTION BUTTON RING (DING~ DONG~)	DOOR OPEN ALARM (SCREECHING)	OFF
IC1 (No.23 Pin)			0V
IC1 (No.22 Pin)			0V

5) TEMP SENSOR CIRCUITS

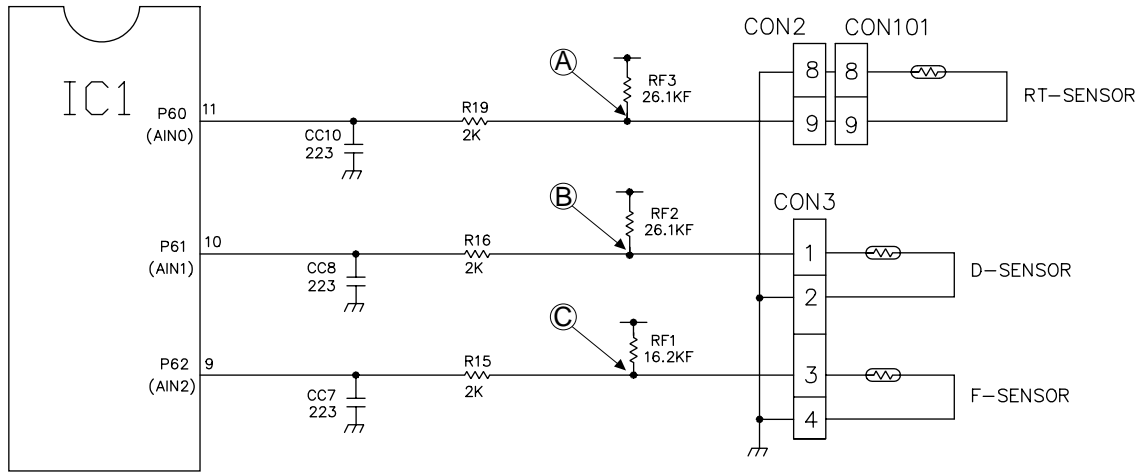

The above circuit reads the surrounding temperature, DEFROSTING temperature and FREEZER ROOM temperature into MICOM(IC1). OPEN or SHORT state of each SENSOR is as follows.

SENSOR	CHECK POINT	NORMAL (-30°C~50°C)	SHORT	OPEN
ROOM TEMPERATURE SENSOR	POINT A Voltage	0.5V ~ 4.5V	0V	5V
DEFROST SENSOR	POINT B Voltage			
FREEZER SENSOR	POINT C Voltage			

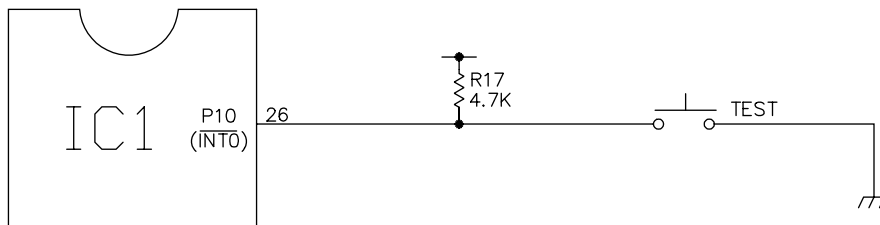

6) SWITCH INPUT CIRCUIT

The following circuit is a test switch input circuit for checking the refrigerator.

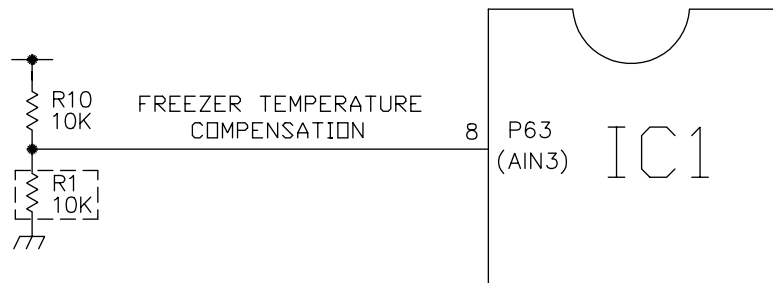

7) TEMPERATURE COMPENSATION



FREEZER ROOM		REMARKS
RESISTANCE VALUES(R1)	TEMPERATURE COMPENSATION	
180 kΩ	+ 5.0°C	COMPENSATE WARMLY 
56 kΩ	+4.0°C	
33 kΩ	+3.0°C	
18 kΩ	+2.0°C	
12 kΩ	+1.0°C	
10 kΩ	0°C	STANDARD
8.2 kΩ	-1.0°C	 COMPENSATE COOLLY
5.6 kΩ	-2.0°C	
3.3 kΩ	-3.0°C	
2 kΩ	-4.0°C	
470 Ω	-5.0°C	

- TEMPERATURE COMPENSATION TABLE by adjusting resistance values. (the temp difference compared to the present temp.)

eg) If the compensation resistance of freezer compartment is changed from 10K (present resistance) to 18K (revised resistance), the temp of freezer compartment goes up by +2°C.

• TEMPERATURE COMPENSATION OF FREEZER ROOM

	Revised resistance	470Ω	2kΩ	3.3kΩ	5.6kΩ	8.2kΩ	10kΩ	12kΩ	18kΩ	33kΩ	56kΩ	180kΩ
	Present resistance											
FREEZER ROOM (R1)	470Ω	NOT COMPENSATE	1°C↑	2°C↑	3°C↑	4°C↑	5°C↑	6°C↑	7°C↑	8°C↑	9°C↑	10°C↑
	2kΩ	1°C↓	NOT COMPENSATE	1°C↑	2°C↑	3°C↑	4°C↑	5°C↑	6°C↑	7°C↑	8°C↑	9°C↑
	3.3kΩ	2°C↓	1°C↓	NOT COMPENSATE	1°C↑	2°C↑	3°C↑	4°C↑	5°C↑	6°C↑	7°C↑	8°C↑
	5.6kΩ	3°C↓	2°C↓	1°C↓	NOT COMPENSATE	1°C↑	2°C↑	3°C↑	4°C↑	5°C↑	6°C↑	7°C↑
	8.2kΩ	4°C↓	3°C↓	2°C↓	1°C↓	NOT COMPENSATE	1°C↑	2°C↑	3°C↑	4°C↑	5°C↑	6°C↑
	10kΩ	5°C↓	4°C↓	3°C↓	2°C↓	1°C↓	NOT COMPENSATE	1°C↑	2°C↑	3°C↑	4°C↑	5°C↑
	12kΩ	6°C↓	5°C↓	4°C↓	3°C↓	2°C↓	1°C↓	NOT COMPENSATE	1°C↑	2°C↑	3°C↑	4°C↑
	18kΩ	7°C↓	6°C↓	5°C↓	4°C↓	3°C↓	2°C↓	1°C↓	NOT COMPENSATE	1°C↑	2°C↑	3°C↑
	33kΩ	8°C↓	7°C↓	6°C↓	5°C↓	4°C↓	3°C↓	2°C↓	1°C↓	NOT COMPENSATE	1°C↑	2°C↑
	56kΩ	9°C↓	8°C↓	7°C↓	6°C↓	5°C↓	4°C↓	3°C↓	2°C↓	1°C↓	NOT COMPENSATE	1°C↑
	180kΩ	10C↓	9°C↓	8°C↓	7°C↓	6°C↓	5°C↓	4°C↓	3°C↓	2°C↓	1°C↓	NOT COMPENSATE

- This circuit is aimed to input the necessary temperature compensation values into the MICOM in order to adjust the freezer temperature which is different in each model.

8) LIGHTING CIRCUITS OF KEY BUTTON INPUT AND DISPLAY PARTS

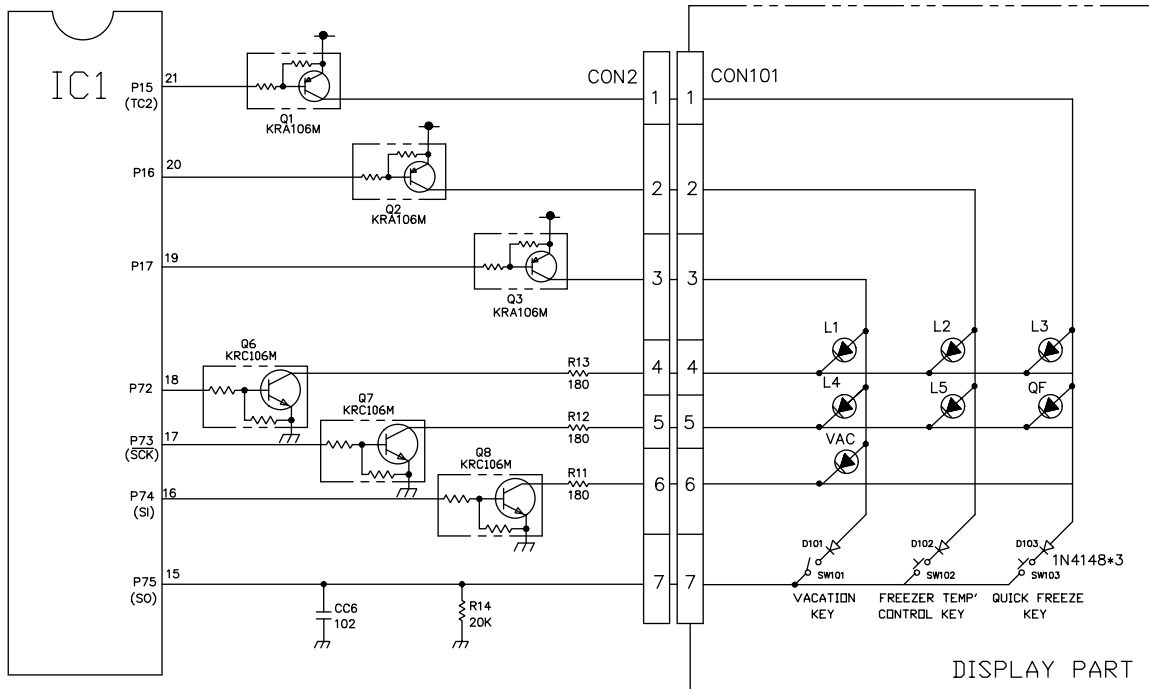

The above circuit is to judge the operation conditions of function key and to light each function indicating LED. It is operated by SCAN method.

3. SENSOR RESISTANCE CHARACTERISTICS TABLE

MEASURED TEMPERATURE	RESISTANCE OF FREEZER SENSOR	RESISTANCE OF DEFROST SENSOR, ROOM TEMPERATURE SENSOR
-20°C	22.3kΩ	77kΩ
-15°C	16.9kΩ	60kΩ
-10°C	13.0kΩ	47.3kΩ
-5°C	10.1kΩ	38.4kΩ
0°C	7.8kΩ	30kΩ
+5°C	6.2kΩ	24.1kΩ
+10°C	4.9kΩ	19.5kΩ
+15°C	3.9kΩ	15.9kΩ
+20°C	3.1kΩ	13kΩ
+25°C	2.5kΩ	11kΩ
+30°C	2.0kΩ	8.9kΩ
+40°C	1.4kΩ	6.2kΩ
+50°C	0.8kΩ	4.3kΩ

- The tolerance of sensor resistance is $\pm 5\%$.
- Be sure to measure the sensor resistance after keeping the sensor more than 3 minutes at a measuring temperature. (It needs delay due to sensor speed.)
- Measure the resistances of SENSORS with a digital tester after disconnecting CON 3 of MAIN PWB ASSY.

4. MAIN PWB ASS'Y AND PARTS LIST

1) MAIN PWB ASS'Y

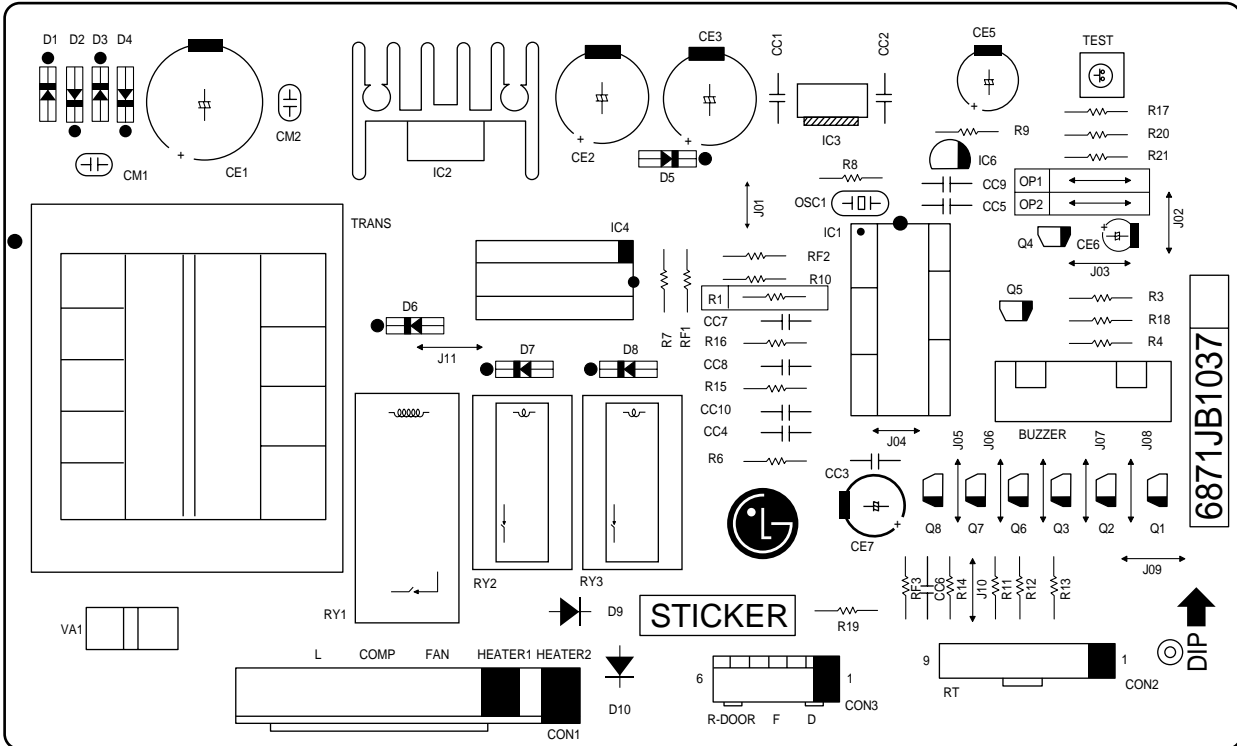

2) REPLACEMENT PARTS LIST

NO.	DWG. NO.	DESCRIPTION	SPEC'	QTY.	MAKER	REMARK
1	6870JB2024C	PWB,MAIN	FR-1(DS-1107A)	1	DOO SAN	t=1.6
2	6170JB2005A	TRANS PCB	I: 240V, O: 14V	1	TAE SUNG	TRANS
3	6630JB8001E	WAFER	E202-1F-06(SP-246,8,10)	1	JAE EUN	CON1
4	6630JB8004H		SMW250-09	1	YEON HO	CON2
5	6630JB8004E		SMW250-06	1		CON3
6	01ZZJB2008G	MICOM CHIP	TMP87C408N	1	TOSHIBA	IC1(=01ZZJB2008H)
7	01RH178120A	REGULATOR	(1)BA17812T	1	ROHM	IC2
8	01KE780500A		KIA78S05P	1	KEC	IC3
9	01KE704200A 01KD010100A	RESET IC	KIA7042P BMR-0101D	1	K.E.C KODENSHI	IC6
10	01KE650030B	DRIVE IC	KID65003AP	1	K.E.C	IC4
11	6920JB2002A	RELAY	VS-12MB	1	TAKAMISAWA	RY1
12	6920JB2003A		G5N-1	2	OMRON	RY2,RY3
13	0570-00012B	RESONATOR	CST4.00MGW-1F01	1	MURATA	OSC1 (=6212AQ9002B)
14	6102JB8001B (6102JB8001B)	VARIATOR	(1)INR14D621 (2)SVC621D-14A	1	IL JIN SAMHWA	VA1
15	0DD400409AA	RECTIFIER DIODE	1N4004	6	(1)DELTA	D1~6
16	0DR154080AA	GLASS RECTIFIER D.	1N5408	2	DELTA	D9,10
17	0DD414800AA	SWITCHING DIODE	1N4148	2	(1)ROHM	D7,8
18	0CE1081J618		1000uF/35V	1		CE1
19	0CE4771H618		470uF/25V	2	(1)SAM HWA	CE2,3
20	0CE2271F638	ELE' CAPACITOR	220uF/16V	2	(2)SAM YOUNG	CE5,7
21	0CE4761H638		47uF/25V	1		CE6
22	6908JB3002A	PIEZO BUZZER	BM-20K	1	BUJEEON	BUZZ
23	0CQ2231N409	MYL' CAPACITOR	223/100V	2	JINYOUNG	CM1,CM2
24	0CK1020H908		102/25V	1		CC6
25	0CK2230H908	CER' CAPACITOR	223/25V	6	TAE YANG	CC1,2,4,7,8,10
26	0CK1040H908		104/50V	3		CC3,5,9
27	ORD1800H608		180J 1/4W	1	(1)K-OHM	R11
28	ORD1800H608	R,CARBON FILM	180J 1/4W	1	(2)DONG HO	R12
29	ORD1800H608		180J 1/4W	1	(3)SUNG YO	R13

NO.	DWG. NO.	DESCRIPTION	SPEC'	QTY.	MAKER	REMARK
30	ORD2200G608		220J 1/4W	1		R18
31	ORD1001G608		1KJ 1/4W	2		R3,R4
32	ORD2001G608		2KJ 1/4W	5		R6,7,15,16,19
33	ORD2201G608		20KJ 1/4W	1		R14
34	ORD4701G608	R,CARBON FILM	4.7KJ 1/4W	4	(1)JOYANG (2)K-OHM (3)DONG HO	R9,17,20,21
35	ORD1002G608		10KJ 1/4W	1		R10
36	ORD1202G608		12KJ 1/4W	1	(4)SUNG YO	R1
37	ORD1004G608		1MJ 1/4W	1		R8
38	ORN1612G408		16.2KF 1/4W	1		RF1
39	ORN2612G408	R,METAL FILM	26.1KF 1/4W	1		RF2
40	ORN2612G408		26.1KF 1/4W	1		RF3
41	0TR106009AC	TRANSISTOR	KRA106M	4	K.E.C	Q1,2,3,4
42	0TR106009AE		KRC106M	4		Q5,6,7,8
43	6600JB8001A	TEST S/W		1		TEST
44			0.6*10mm	9		J01,02,04,05,15 J02,03,05~11
45	43607015	JUMP WIRE	0.6*7.5mm	2		J01,04
46			0.6*10mm	1		OP1
47	4920JB3002A	HEAT SINK(12V)	(=J572-00003A)	1		(IC2)
48	1SBF0302418	SCREW	H/SINK와 조립	1		
49	49111001	SOLDER	ALMIT KR-19RMA	3.0g		
50	49111004	SOLDER LEAD BAR	H63A	25g		
51	59333105	FLUX AUTO	JS71	1.5g	KOKI	

3) PWB ASS'Y, DISPLAY AND PARTS LIST

품번 NO.	도 번 DWG. NO.	품 명 DESCRIPTION	재 질 MATERIAL	소재지수 SPEC.	수량 QTY.	MAKER	비 고 REMARK
1	6870JB2025	PWB, DISPLAY	FR-1(DS-1107A)		1A	DOOSAN	
2	6630JB8005B	WAFER	SMAW250-09			YEON HO	
3	6600JB8004A	TACT S/W	KPT-1109R		2	KYUNG IN	SW101, SW103
4	6600JB8005A	TACT S/W	KPT-1105A		1	KYUNG IN	SW102
5							
6	ODL300359AA	LED	SH30-R03CA570GT	GREEN	5	SEOUL SEMI.	L1~L5
7	ODD414809AA	S/W DIODE	1N4148		3	ROHM	D101~D103
8	6500JB3001A	SENSOR	PBN-43		1	계림스텍	RT-SENSOR
9	6877JB2049A	L/WIRE ASSY, FD/H			1		
10							
11							
12							
13							
14	43607015	JUMP WIRE	0.6*6mm		1		J04
15		JUMP WIRE	0.6*10mm		2		J02, J03
16		JUMP WIRE	0.6*12.5mm		1		J01
17	49111001	SOLDER	ALMIT KR-19RMA		2g	희성금속	
18	49111004	SOLDER LEAD BAR	S63S-B20		5g	희성, 대진 SOLD'	
19	59333105	FLUX AUTO	JS71		0.5g	KOKI	
20	————	희석제	IPA			KOKI, 주)유공	

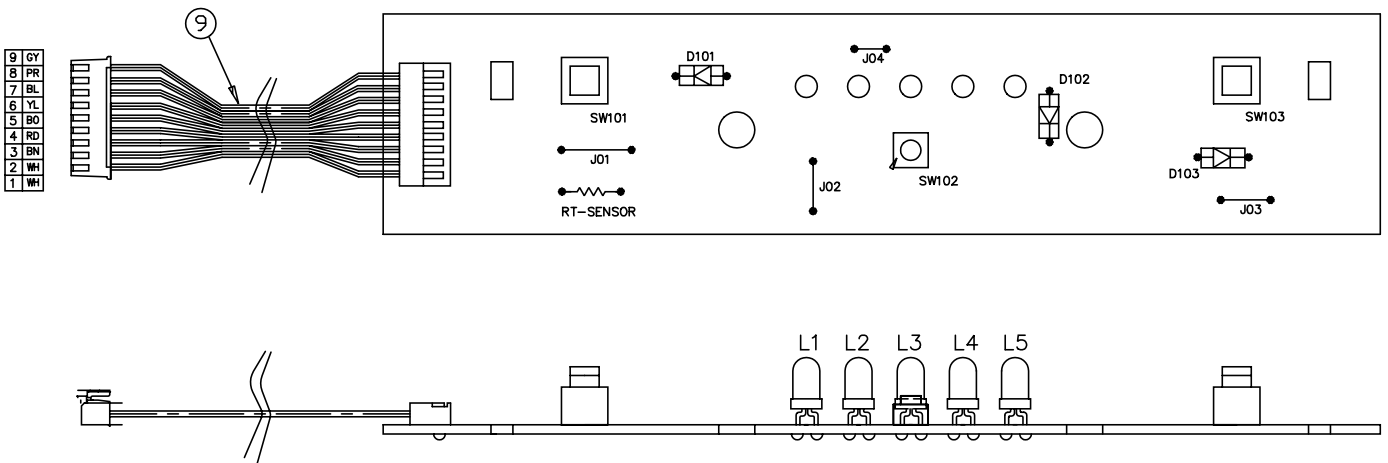

5. PWB circuit drawing- The PWB circuit drawing may change without notice.

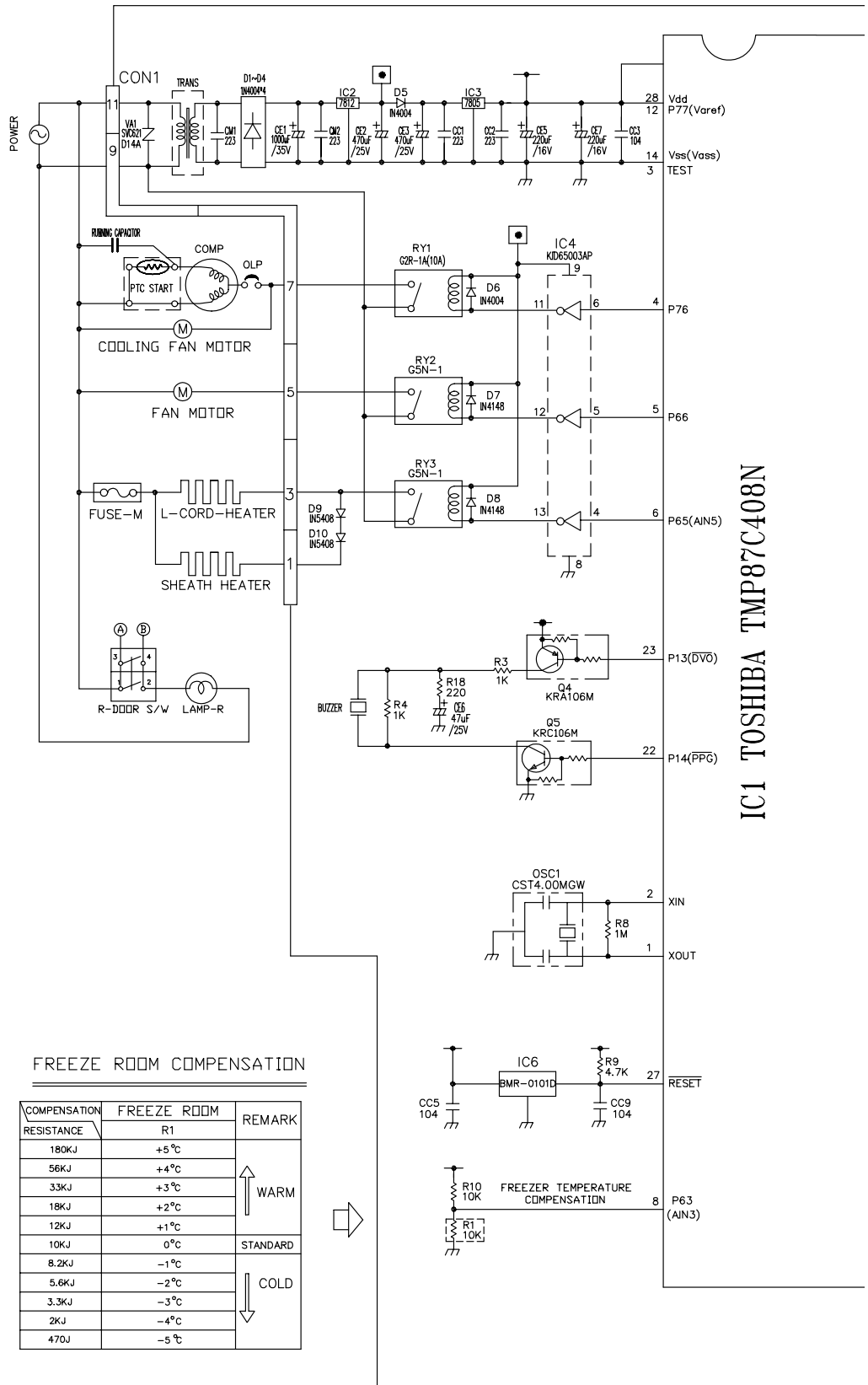

IC1 TOSHIBA TMP87C408N

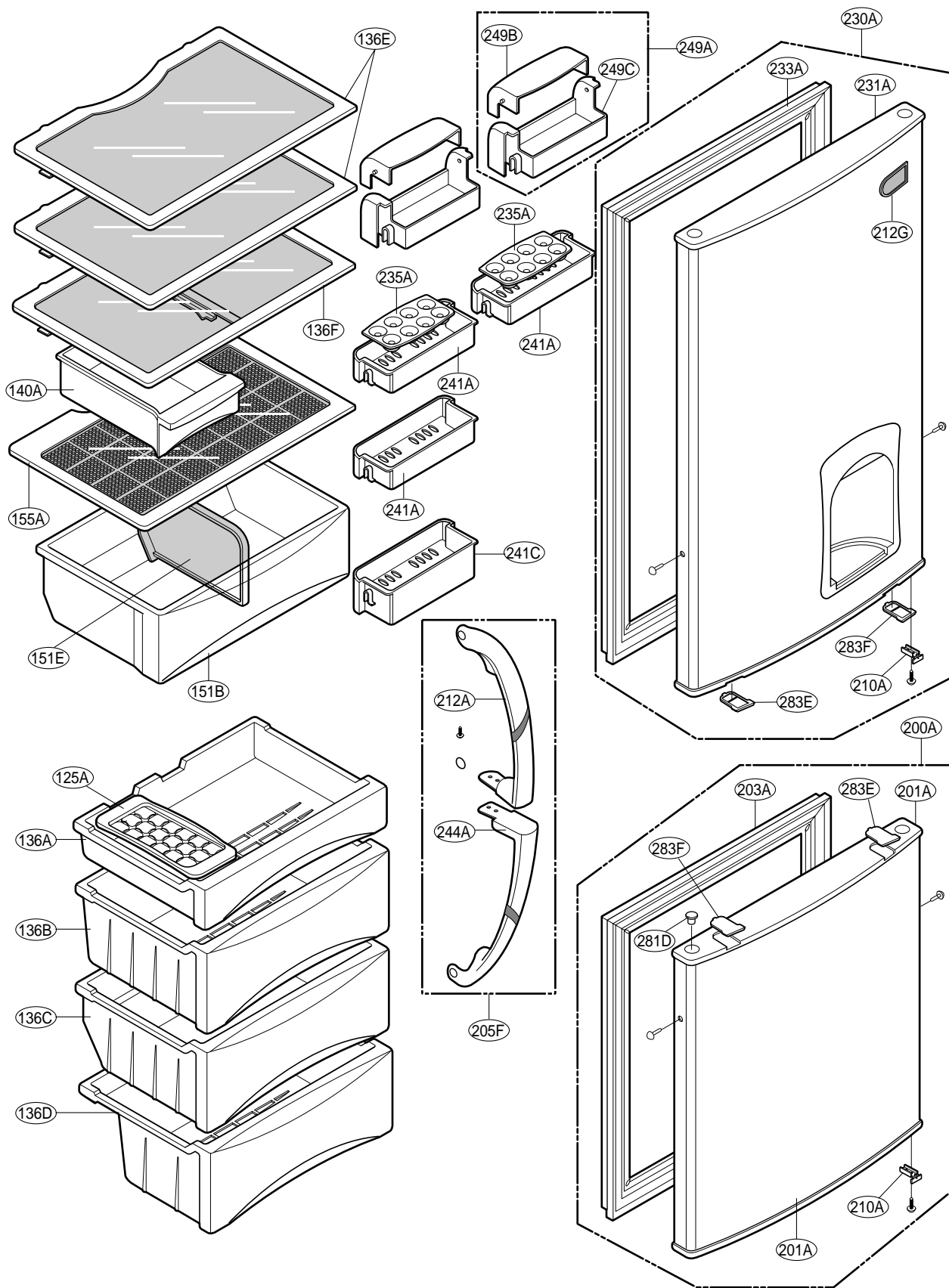

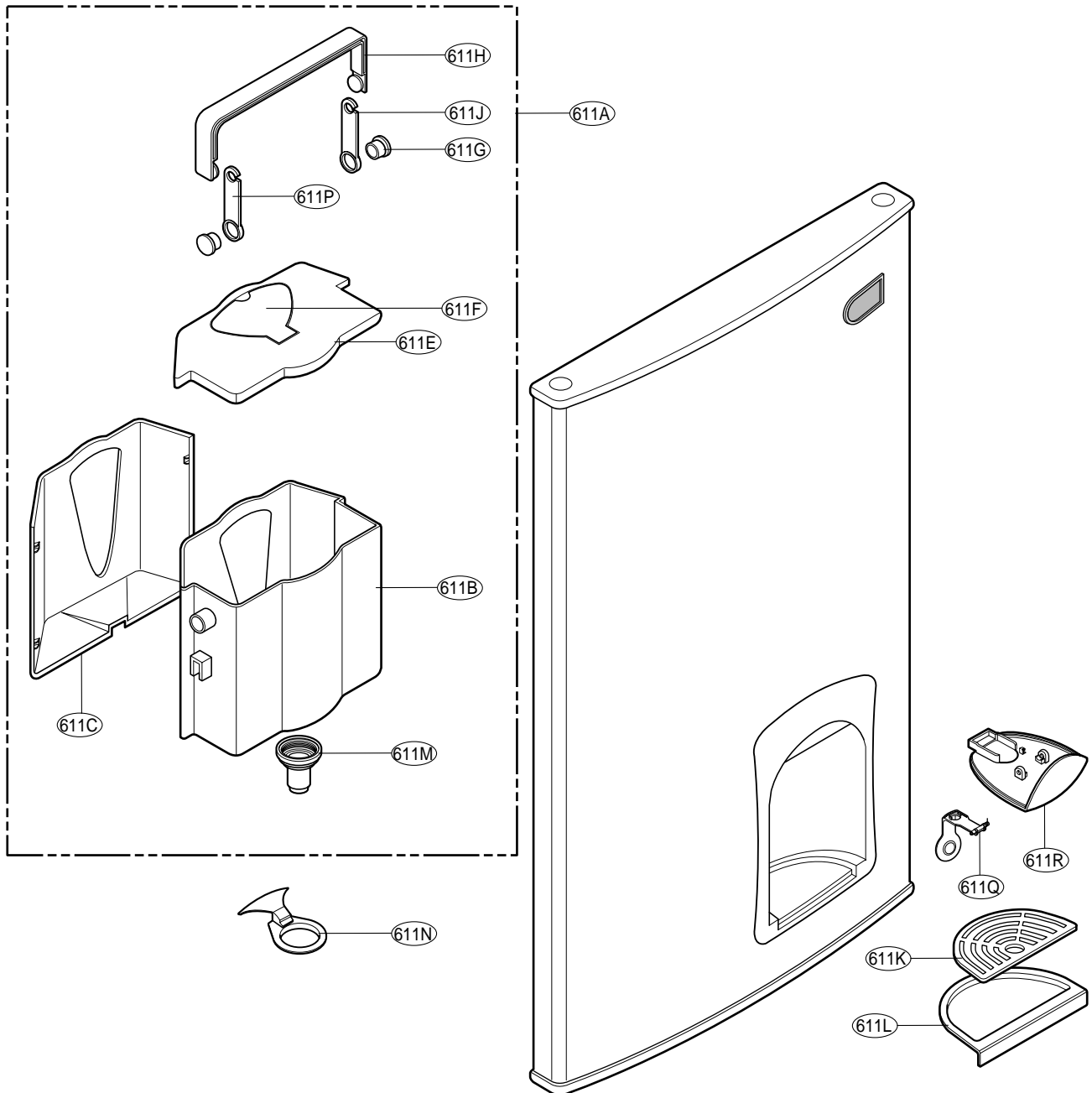

Ref. No : GR-409 GQA/GTQA/GVQA/GLQA

