

# NSMI - BSMI

User manual

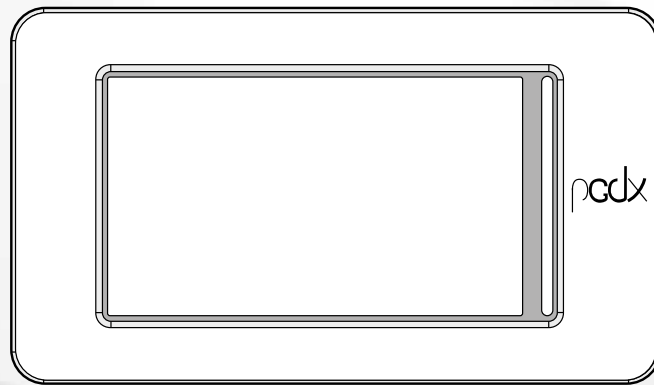

---

■ **CARD PC05 - TOUCH PANEL**

Dear Customer,

Thank you for wanting to learn about a product Aermec. This product is the result of many years of experience and in-depth engineering research, and it is built using top quality materials and advanced technologies.

The manual you are about to read is meant to present the product and help you select the unit that best meets the needs of your system.

However, please note that for a more accurate selection, you can also use the Magellano selection program, available on our website.

Aermec, always attentive to the continuous changes in the market and its regulations, reserves the right to make all the changes deemed necessary for improving the product, including technical data.

Thank you again.

Aermec S.p.A.

#### SAFETY CERTIFICATIONS



This marking indicates that this product should not be disposed with other household wastes throughout the EU. To prevent possible harm to the environment or human health from uncontrolled disposal of Waste Electrical and Electronic Equipment (WEEE), please return the device using appropriate collection systems, or contact the retailer where the product was purchased. Please contact your local authority for further details. Illegal dumping of the product by the user entails the application of administrative sanctions provided by law.

---

All specifications are subject to change without prior notice. Although every effort has been made to ensure accuracy, Aermec shall not be held liable for any errors or omissions.

# TABLE OF CONTENTS

<p>1. <b>Quick reference</b> ..... p. 4</p> <p>2. <b>Structure of the menus</b> ..... p. 5</p> <p style="padding-left: 20px;">Interacting with the graphic interface ..... p. 5</p> <p style="padding-left: 20px;">Navigating between the program pages ..... p. 5</p> <p style="padding-left: 20px;">Setting a numerical value for a parameter ..... p. 6</p> <p style="padding-left: 20px;">Setting a value, selecting it from a list ..... p. 6</p> <p>3. <b>Main page (HOME)</b> ..... p. 7</p> <p style="padding-left: 20px;">Data entered in the upper bar ..... p. 7</p> <p style="padding-left: 20px;">Water inlet/outlet temperature chart ..... p. 7</p> <p style="padding-left: 20px;">Unit operating status information (real time data) ..... p. 7</p> <p style="padding-left: 20px;">Data entered in the lower bar, and navigation keys ..... p. 8</p> <p>4. <b>Input/output menu</b> ..... p. 9</p> <p style="padding-left: 20px;">General status of Inputs/Outputs and compressors ..... p. 9</p> <p style="padding-left: 20px;">Status of analogue inputs ..... p. 9</p> <p style="padding-left: 20px;">Status of analogue outputs ..... p. 9</p> <p style="padding-left: 20px;">Compressor state ..... p. 10</p> <p>5. <b>ON/OFF menu</b> ..... p. 10</p> <p style="padding-left: 20px;">Switching the unit ON/OFF ..... p. 10</p> <p>6. <b>System menu</b> ..... p. 11</p> <p style="padding-left: 20px;">Setting of the work setpoint ..... p. 11</p> <p>7. <b>Installer menu</b> ..... p. 11</p> <p style="padding-left: 20px;">Entering the password for accessing the protected menu ..... p. 11</p> <p style="padding-left: 20px;">Selecting the sub-menus ..... p. 11</p> <p style="padding-left: 20px;">Enables input filters and compressors ..... p. 12</p> <p style="padding-left: 20px;">Enabling and setting control via the remote supervisor (BMS) ..... p. 12</p> <p style="padding-left: 20px;">Offset configuration on analogue inputs ..... p. 12</p> <p style="padding-left: 20px;">Configuring the antifreeze conditions ..... p. 13</p> <p style="padding-left: 20px;">Pump and compressor functioning log ..... p. 13</p> <p style="padding-left: 20px;">DCP Settings or inverter fans ..... p. 13</p> <p style="padding-left: 20px;">Enables Freecooling Glicole Free ..... p. 13</p> <p style="padding-left: 20px;">Settings Free Glycol Freecooling ..... p. 14</p> <p style="padding-left: 20px;">Date and time settings on the main board and on the touch display board ..... p. 14</p>	<p style="padding-left: 20px;">Software Version ..... p. 14</p> <p>8. <b>Alarm Menu</b> ..... p. 15</p> <p style="padding-left: 20px;">Main alarm page ..... p. 15</p> <p style="padding-left: 20px;">Active alarms page ..... p. 15</p> <p style="padding-left: 20px;">Alarm history ..... p. 15</p> <p style="padding-left: 20px;">List of alarms ..... p. 16</p> <p>9. <b>Diagram menu</b> ..... p. 17</p> <p style="padding-left: 20px;">Chart showing temperature trend of inlet/outlet water on heat exchanger ..... p. 17</p> <p style="padding-left: 20px;">Condenser (water/water unit) Inlet/Outlet water temperature trend chart ..... p. 17</p> <p style="padding-left: 20px;">Compressor trend chart ..... p. 17</p> <p style="padding-left: 20px;">High and Low pressure trend chart ..... p. 17</p> <p>10. <b>Summary menu</b> ..... p. 18</p> <p style="padding-left: 20px;">Page relating to the Cooling Only units ..... p. 18</p> <p style="padding-left: 20px;">Page relating to the units with Freecooling ..... p. 18</p> <p style="padding-left: 20px;">Page relating to the units with Free glycol freecooling ..... p. 18</p> <p style="padding-left: 20px;">Page relating to the units with Recovery ..... p. 18</p> <p>11. <b>Time band menu</b> ..... p. 19</p> <p style="padding-left: 20px;">Page for creating timed programs ..... p. 19</p> <p>12. <b>Language menu</b> ..... p. 19</p> <p style="padding-left: 20px;">Page for selecting the system language ..... p. 19</p> <p>13. <b>Help menu</b> ..... p. 19</p> <p>14. <b>Multi-purpose input menu</b> ..... p. 19</p> <p style="padding-left: 20px;">Displays the status of multi-function input U7 ..... p. 19</p>
--	--

# 1 QUICK REFERENCE

This manual describes all the windows found in the control software of the Touch panel, but the list below contains all the basic operations that the user might need,











referring him/her to the relative page of the manual where there is a description of that specific function (for all other information, refer to the contents page):



- A Switching the unit ON/OFF (5.1 Switching the unit ON/OFF p. 10)
- B Selecting the operating mode (6.1 Setting of the work setpoint p. 11)
- C Setting a main operating set-point (6.1 Setting of the work setpoint p. 11)
- D Setting the time bands (11 Time band menu p. 19)
- E Applying a timed program (11.1 Page for creating timed programs p. 19)
- F Changing the system language (12.1 Page for selecting the system language p. 19)

## 2 STRUCTURE OF THE MENUS

With the touch panel, the user can manage all the operating parameters of the unit via a touchscreen graphic interface. The use of the information is easy and straightforward, thanks to the "home" page showing the main unit operating parameters. The more specific parameters and settings can be found in the various menus, accessed via the relative selection page that identifies each menu with a specific icon. These icons are highlighted below:

	Input/output menu
	ON/OFF menu
	System menu
	Installer menu (password 0000)
	Alarm Menu
	Diagram menu
	Summary menu
	Time band menu
	Language menu
	Help menu (PROTECTED menu)
	Multi-purpose input menu

### 2.1 INTERACTING WITH THE GRAPHIC INTERFACE

The unit command and control interface uses a touchscreen display. This interface is designed to be simple and user-friendly; the absence of actual keys means the program is managed purely by touching the screen directly, which makes it far more accessible for the user. The software manages a great deal of information, with the various items grouped into separate pages that in turn are managed via specific menus, but there are certain fundamental features that apply to all the operations, such as selecting a window, moving on to the next window, or entering a precise numerical value. The basic operations that can be carried out via the touchscreen interface are described below.



**⚠ NB:** The following pages show all the masks contained in the menus available to the user; Tampering with the parameters in the installer menu could cause the unit to malfunction, therefore it is recommended to have these parameters changed only by personnel assigned to unit installation and configuration.

### 2.2 NAVIGATING BETWEEN THE PROGRAM PAGES

As already mentioned on the previous pages, the unit operating information is sub-divided into various menus, each containing several pages. The basic operations for navigating between the menus are as follows:

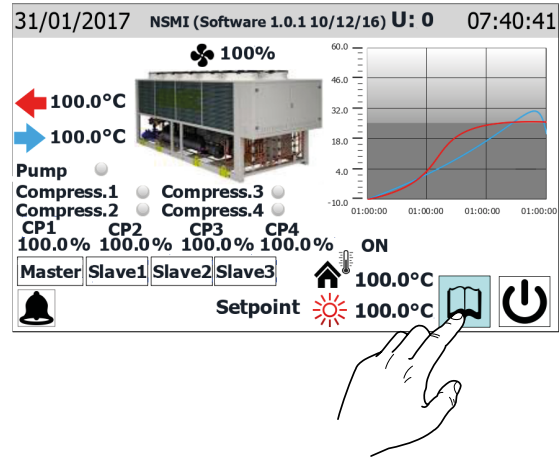
— **Access a menu:** to access a menu you must activate the menu selection page by pressing the "open book" icon () found on every page of the program. Now, just press the icon that represents the specific menu you want to access (for more information about which menus are activated by the various icons, refer to the diagram on the previous page).



— **Scroll to the next or previous page of a menu:** once you have accessed a menu, you can pass from one page to another by pressing the "right arrow" icon () to go forward, or the "left arrow" icon () to go back (unless the menu in question has just one page).

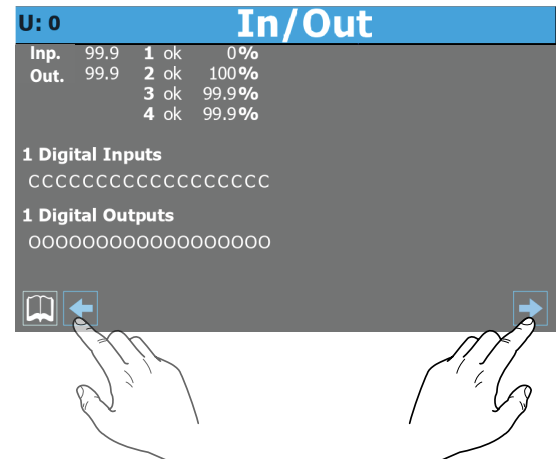

— **Return to the "Home" page:** to go back to the main (home) page, press the relative icon () ; Not all the program pages contain this icon, but you can find it on the menu selection page so just go to that page (as explained in the first point of this list) and from there you can reach "Home".

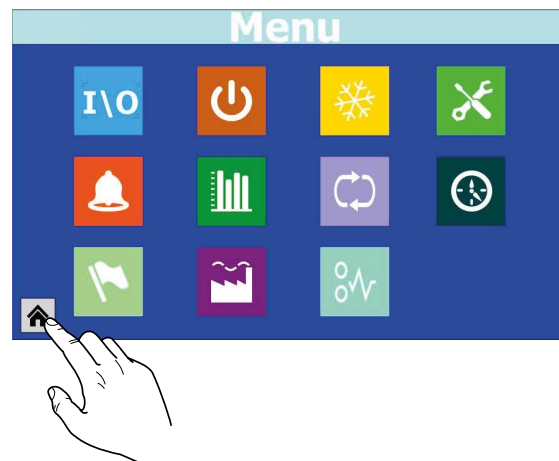

## 2.3 SETTING A NUMERICAL VALUE FOR A PARAMETER

Many parameters (e.g. the seasonal operating set-points) require the user to enter a numerical value. In these cases, proceed as follows:

1. Once you have accessed a page containing an editable numerical value (e.g. the operating set-points), press on the value already displayed.

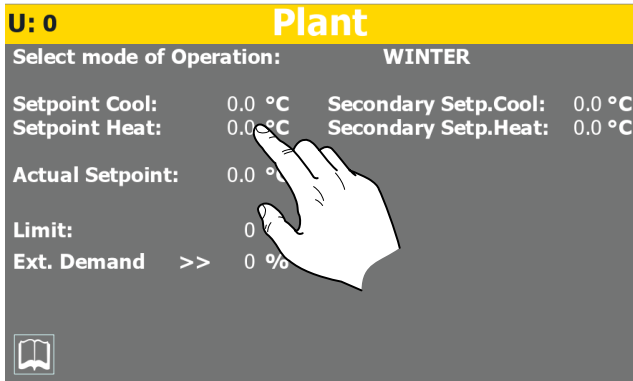

2. A numerical keypad will now appear, where you can enter a new value;
3. Press "Enter" on the keypad to confirm and apply the new value, or press "Esc" to delete the operation.

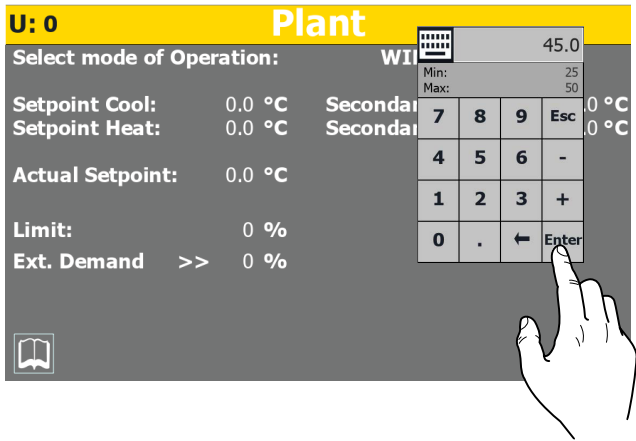

**!** Once you have selected the numerical value to be modified, the numerical keypad will show the Minimum and Maximum values that can be set for that parameter.

## 2.4 SETTING A VALUE, SELECTING IT FROM A LIST

Certain parameters (such as the operating mode) require the user to choose an option from a list. In these cases, proceed as follows:

1. Once you have accessed a page containing an editable value (e.g. the operating mode), press on the option already displayed;

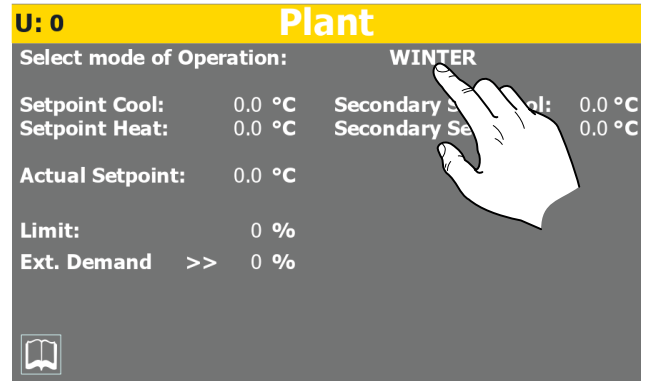

2. A small window will now appear, with a list of options;
3. Select one of the options by pressing on it. Your choice will be highlighted by a change of colour;
4. Press "OK" to apply the chosen option, or press "Cancel" to quit the selection page without altering the previous value;

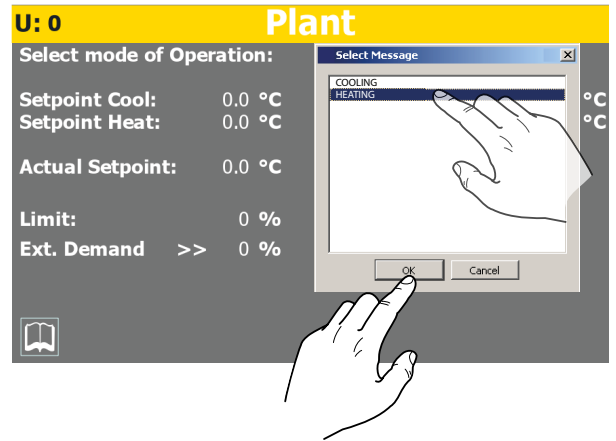

### 3 MAIN PAGE (HOME)

The standard display during normal operation is the "Home" page. Depending on the type of unit configured, from this window you can keep the main operating parameters under control or access direct connections to certain operating menus. We will analyse and explain below all the elements that can be viewed and/or managed via the Home page.

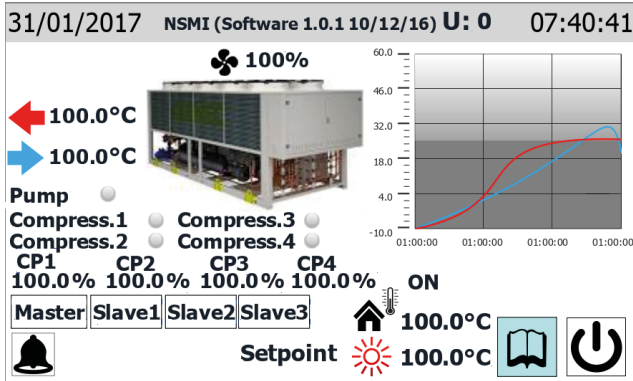

**ATTENTION:** some displays are only available if the unit is provided with them (e.g. data relating to the master/slave unit).

### 3.1 DATA ENTERED IN THE UPPER BAR

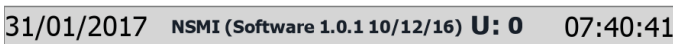

- Date set on the system
- String indicating the software version loaded on the unit
- Indicates the unit to which the displayed data refers (U1 = Master, U2 = Slave 1, U3 = Slave 2, U4 = Slave 3)
- Time set on the system

**Note:**

The units have two different timers - one integrated in the touch panel and the other relating to the electric control card of the units. These timers can have different time settings (which can be seen on the "Clock configuration" page of the installer menu), to ensure the correct time is shown for any alarms saved in the log. You are advised to check them regularly to make sure they coincide, synchronising them if necessary.

The configured unit code is entered in the factory, and cannot be altered by the user.

### 3.2 WATER INLET/OUTLET TEMPERATURE CHART

The chart on the homepage shows the temperature trend of the water entering and leaving the unit. The colours will depend on the unit operating mode: in cooling mode, BLUE indicates the outlet water and RED the inlet water; on the contrary, in heating mode RED indicates the processed water and BLUE the water returning from the system.

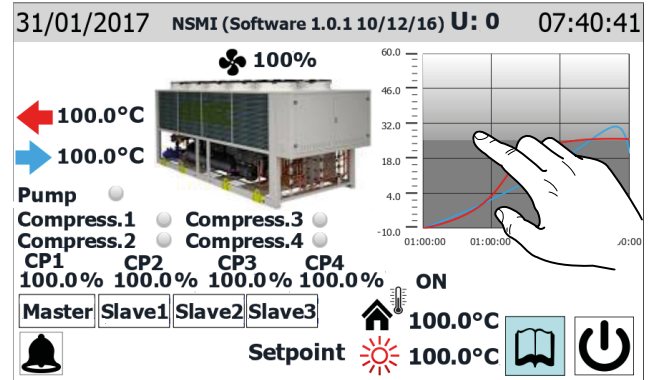

Click on the chart to directly open the "chart menu", where you can see a log of the various charts available. To return to the main page, you must first go to the menu selection page and from there select "Home".

### 3.3 UNIT OPERATING STATUS INFORMATION (REAL TIME DATA)

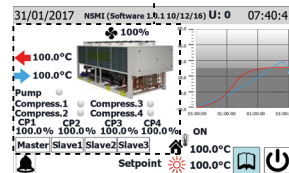
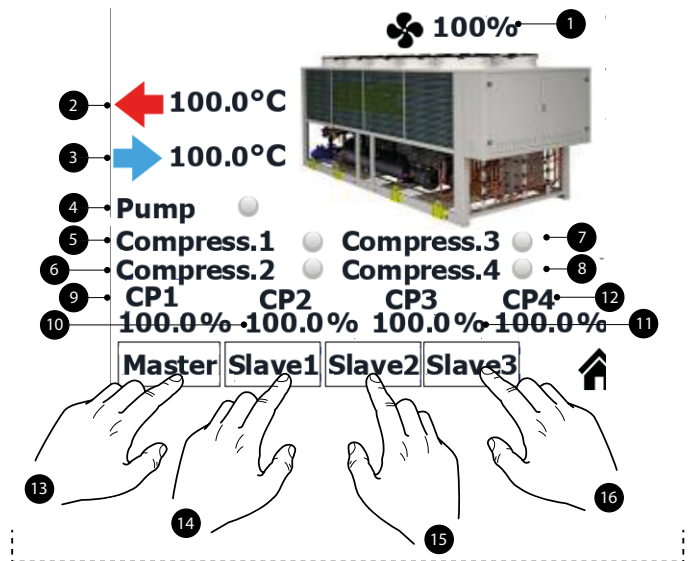

**Note:** Many of the displays of this section relate to the type of unit; the presence of one or more units managed according to the Master/Slave logic depends on the type of unit;

1. Percentage value of the fan speed
2. Indicates the temperature of the water processed by the unit (real time figure)
3. Indicates the temperature of the water entering the unit (real time figure)
4. This label appears if the unit pump is active (if the unit has a pump component)
5. This label appears if compressor 1 is on
6. This label appears if compressor 2 is on
7. This label appears if compressor 3 is on
8. This label appears if compressor 4 is on
9. Percentage data on the power supplied by compressor 1
10. Percentage data on the power supplied by compressor 2

11. Percentage data on the power supplied by compressor 3
12. Percentage data on the power supplied by compressor 4
13. This key selects the Master compressor as data source (this selection is only available on the Master unit)
14. This key selects the Slave 1 compressor as data source (this selection is only available on the Master unit)
15. This key selects the Slave 2 compressor as data source (this selection is only available on the Master unit)
16. This key selects the Slave 3 compressor as data source (this selection is only available on the Master unit)



**ATTENTION:** via serial (pLAN connection), the pCO5 control board can manage up to 4 compressors, which are identified as:

**U1:** Master;  
**U2:** Slave 1;  
**U3:** Slave 2;  
**U4:** Slave 3;

**THE MAXIMUM NUMBER OF UNITS THAT CAN BE CONNECTED VIA SERIAL (pLAN) DEPENDS ON THE NUMBER OF COMPRESSORS THAT THE UNIT HAS. In fact, if the system contains only one bi-compressor unit, the interface will show as available the Master data (U:1) and the Slave 1 data (U:2); similarly, the same case might indicate that the system is composed of two separate single-compressor units.**

### 3.4 DATA ENTERED IN THE LOWER BAR, AND NAVIGATION KEYS

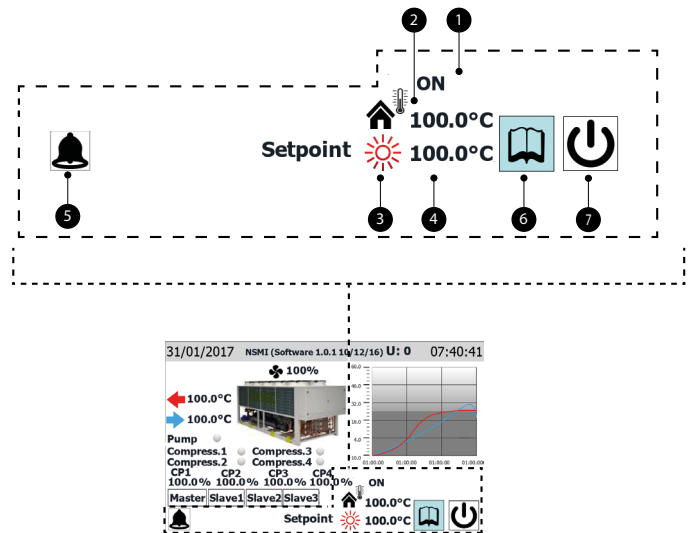

1. Current unit status; the possible displays on the unit are:  
 On = Unit functioning;  
 Off from alarm = Unit switched off due to the arising of an alarm condition;  
 OFF via supervisor = Unit switched off via BMS;  
 Off from range = Unit switched off because required by currently active time period;  
 Off from dig.inp. = Unit switched off by signal on digital input (ID1);  
 Off from keyboard = Unit switched off through key (6);  
 Pumpdown = Unit currently engaged in pumpdown cycle;
2. Value of the outside air temperature (real time value)
3. This icon indicates the current set-point being used (summer or winter) on the basis of the selected operating mode
4. Indicates the current value for the operating set-point
5. This icon is displayed if there is an active alarm on the system - press it to view the alarm menu
6. Press this key to visualise the menu selection page
7. Press this key to switch the unit ON or OFF directly

**Note:** If the system uses a MASTER/SLAVE configuration, remember that up to two units can be managed with a "pLAN" serial connection (the address of the touch MASTER panel must be "3", and that of the SLAVE "4"). It is recommended that the two units - Master and Slave - are the same (same software version), so they can be used in a balanced manner.



**WARNING:** it is essential that the Master and Slave units have the same software version.

## 4 INPUT/OUTPUT MENU

The input/output menu shows many of the values measured by the various probes and transducers on the unit. You cannot set any values via this menu, but it gives important operating information such as the defrosting status and so on.

**NOTE:** The top-left corner of each window shows which compressor is currently providing the displayed data (U:1,2,3 o 4); to switch between compressors (only possible from Master unit), refer to that explained in paragraph "3.3 Unit operating status information (real time data) p. 7".

### 4.1 GENERAL STATUS OF INPUTS/OUTPUTS AND COMPRESSORS

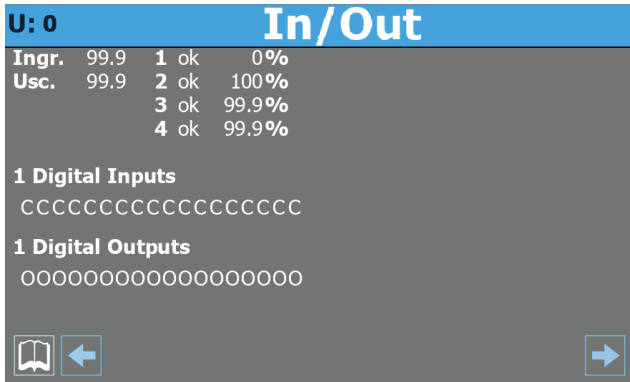

— Indicates to which compressor the displayed data refers (U:1 = Master; U:2 = Slave 1; U:3 = Slave 2; U:4 = Slave 3)

— Actual water temperature value detected at unit inlet

— Actual water temperature value detected at unit outlet

— Status of compressor 1 and actual percentage load of use of the same; the compressor status can be:

ok = indicates that the compressor è operating;

al = indicates that the compressor is stopped for alarm;

sp = indicates that the compressor is currently in "safety partialisation" mode;

F = indicates that the Freecooling mode is currently active;

WW = indicates that the compressor is currently in stand-by for safety differential;

PD = indicates that the compressor is currently in stand-by for pump-down;

--- = compressor not present;

— Status of compressor 2 and actual percentage load of use of the same; the compressor status can be:

ok = indicates that the compressor è operating;

al = indicates that the compressor is stopped for alarm;

sp = indicates that the compressor is currently in "safety partialisation" mode;

F = indicates that the Freecooling mode is currently active;

WW = indicates that the compressor is currently in stand-by for safety differential;

PD = indicates that the compressor is currently in stand-by for pump-down;

--- = compressor not present;

— Status of compressor 2 and actual percentage load of use of the same; the compressor status can be:

ok = indicates that the compressor è operating;

al = indicates that the compressor is stopped for alarm;

sp = indicates that the compressor is currently in "safety partialisation" mode;

F = indicates that the Freecooling mode is currently active;

WW = indicates that the compressor is currently in stand-by for safety differential;

PD = indicates that the compressor is currently in stand-by for pump-down;

--- = compressor not present;

— Status of compressor 1 and actual percentage load of use of the same; the compressor status can be:

ok = indicates that the compressor è operating;

al = indicates that the compressor is stopped for alarm;

sp = indicates that the compressor is currently in "safety partialisation" mode;

F = indicates that the Freecooling mode is currently active;

WW = indicates that the compressor is currently in stand-by for safety differential;

PD = indicates that the compressor is currently in stand-by for pump-down;

--- = compressor not present;

— Each character of this string (starting from left) indicates the status of a digital input; the first character indicates the status of ID1, the second of ID2, and so on up to ID18 (O = open; C = closed)

— Each character of this string (starting from right) indicates the status of a digital output; the first character indicates the status of C1, the second of C2, and so on up to C18 (O = open; C = closed)

### 4.2 STATUS OF ANALOGUE INPUTS

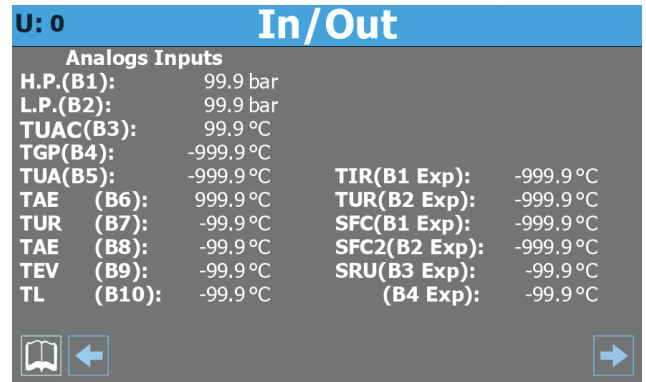

— Indicates to which compressor the displayed data refers (U:1 = Master; U:2 = Slave 1; U:3 = Slave 2; U:4 = Slave 3)

— Current pressure value measured on the high-pressure side of the refrigerant circuit

— Current pressure value measured on the low-pressure side of the refrigerant circuit

— This parameter may vary depending on the unit displayed:

TIA (B3) = Indicates the actual temperature value read at evaporator input (master only);

TUAC (B3) = Indicates the actual temperature value read at common water outlet, in case of outlet adjustment with multiple evaporators in parallel (only for Slave 1 unit);

— Indicates the actual temperature value read on the high pressure side of the cooling circuit

— Indicates the current temperature value measured on the evaporator outlet

— Indicates the actual current value read at amperometric transformer input

— This parameter may vary depending on the unit displayed:

(B7) = Indica lo stato attuale dell'ingresso multifunzione (solo unità Master);

TUR (B7) = Indicates the actual temperature value read at recovery unit output (for Slave units only);

— Indicates the current outside air temperature

— Indicates the actual temperature value read on the gas side at evaporator input

— Indicates the actual liquid temperature value

— Indicates the actual temperature value of the total recovery inlet water

— Indicates the actual temperature value of the total recovery outlet water

— Indicates the actual temperature value of the freecooling inlet water

— Indicates the actual temperature value of the freecooling outlet water

— Indicates the actual temperature value of the intermediate heat exchanger inlet water

— B4 Exp: Not used

### 4.3 STATUS OF ANALOGUE OUTPUTS

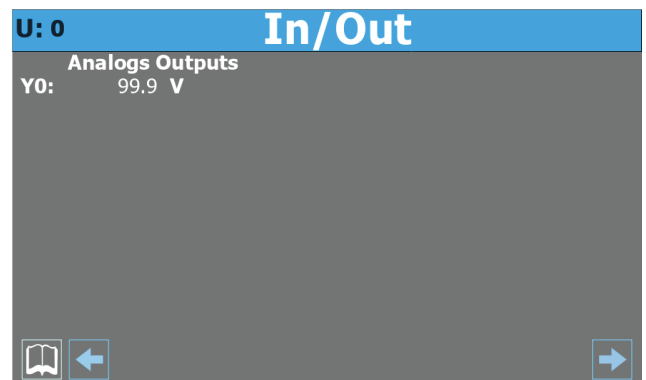

— Indicates to which unit the displayed data refers (U:1 = Master; U:2 = Slave 1; U:3 = Slave 2; U:4 = Slave 3)

— Indicates the current voltage for the fan control

## 4.4 COMPRESSOR STATE

U: 0		In/Out	
Inverter		Input Analog Inverter	
Speed	9999 RPM	T.Aspiration	99.9 °C
State Invert.	Stopped	T.Flow	99.9 °C
Zone Invert.	OK	Temp. Oil	99.9 °C
Coast	NO	Time min On	9999 s
AI	NO	Time min Off	9999 s
Enab	NO		
OnRef	NO		
Run	NO		
Start	NO		
Warn	NO		

- Indicates to which compressor the displayed data refers (U:1 = Master; U:2 = Slave 1; U:3 = Slave 2; U:4 = Slave 3)
- Indicates the actual inverter compressor speed value
- Indicates the actual status of the inverter compressor; this adjustment can be: Stopped = the compressor is stopped; Starting = the compressor is starting; Running = the compressor is running; Stopping = the compressor is stopping; Warning = the compressor is in possible error phase; Critical = the compressor is under critical functioning; Alarm = the compressor is stopped for alarm;
- Indicates the actual area (relative to the compressor operating range) in which the compressor is working; this area can be: OK = optimal functioning; SLDL = low intake and flow temperatures; SL = low intake temperature; SLDH = low intake temperature and high flow temperature; DH = high flow temperature; SHDH = high intake and flow temperatures; SH = high intake temperature; SHDL = high intake temperature and low flow temperature; DL = low flow temperature;
- Indicates the status for the immediate compressor block control (communicated both via serial and as status of the C4 digital output on the J13 terminal connected via isolation relay to terminals 6-7 of CN11 on the inverter; Open = blocked): NO = compressor block; YES = compressor not blocked;
- Indicates the status of the alarm summary: NO = no alarm; YES = alarm(s) present;
- Indicates the status for compressor enabling: NO = compressor not enabled; YES = compressor enabled;
- Indicates the status of the compressor normal functioning (on and outside the initial ramp): NO = compressor outside normal functioning; YES = compressor under normal functioning;
- Indicates whether the compressor is on: NO = compressor off; YES = compressor on;
- Indicates the status for compressor start-up enabling: NO = compressor not enabled to start; YES = compressor enabled to start;
- Indicates the present of a warning status on the compressor: NO = no warning on the compressor; YES = warning on the compressor;
- Indicates the actual temperature value read at compressor intake
- Indicates the actual temperature value read at compressor flow
- Indicates the actual temperature value read for the compressor oil
- Indicates the actual value of the minimum functioning time remaining
- Indicates the actual value of the minimum switch-off time remaining

## 5 ON/OFF MENU

The ON/OFF menu is used to switch the unit on or off. It also provides further information about the current status of the machine.

■ *NOTE: The top-left corner of each window shows which compressor is currently providing the displayed data (U:1,2,3 o 4); to switch between compressors (only possible from Master unit), refer to that explained in paragraph "3.3 Unit operating status information (real time data) p. 7".*

### 5.1 SWITCHING THE UNIT ON/OFF

U: 0		On/Off	
General Enable:		NO	

- Indicates to which compressor the displayed data refers (U:1 = Master; U:2 = Slave 1; U:3 = Slave 2; U:4 = Slave 3)
- Indicates the current value selected (YES = Unit ON; NO = Unit OFF)

■ *Note: In case of systems with multiple compressors, the OFF command given by selecting the master (U:1) turns off ALL compressors, while if a particular Slave (U:2, 3, 4) is selected only the circuit of the same will be switched off.*

## 6 SYSTEM MENU

The SYSTEM menu is used to set the operating mode and the set-point values for the various modes.

■ **NOTE:** The top-left corner of each window shows which compressor is currently providing the displayed data (U:1,2,3 o 4); to switch between compressors (only possible from Master unit), refer to that explained in paragraph "3.3 Unit operating status information (real time data) p. 7".

### 6.1 SETTING OF THE WORK SETPOINT

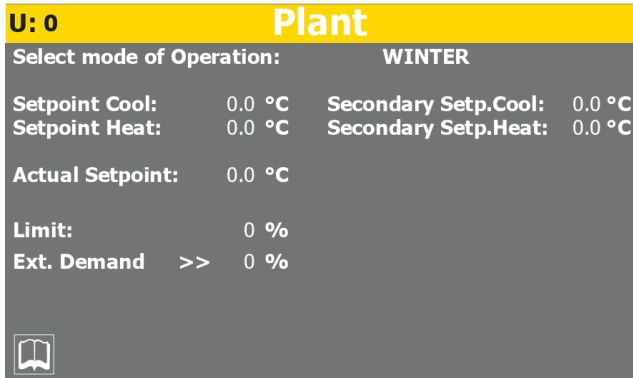

- Indicates to which compressor the displayed data refers (U:1 = Master; U:2 = Slave 1; U:3 = Slave 2; U:4 = Slave 3)
- Indicates the actual value assigned to the main cooling setpoint
- Indicates the actual value assigned to the secondary cooling setpoint
- Indicates the value currently displayed as work setpoint
- Indicates the percentage value relative to the thermostat limit (set from outside)
- Indicates the percentage value of the external thermostat request

## 7 INSTALLER MENU

The INSTALLER menu is used to access many of the settings for operating and adjusting the unit; it may, however, contain parameters that should only be modified by persons responsible for maintenance and/or assistance on the unit or system, and for this reason it's protected by a password.

**USER PASSWORD: 0000**

■ **NOTE:** The top-left corner of each window shows which compressor is currently providing the displayed data (U:1,2,3 o 4); to switch between compressors (only possible from Master unit), refer to that explained in paragraph "3.3 Unit operating status information (real time data) p. 7".

### 7.1 ENTERING THE PASSWORD FOR ACCESSING THE PROTECTED MENU



1. This key is used to quit the window and go back to the menu selection page
2. Indicates the current value of the password to be used for accessing the installer menu
3. This key is used to confirm the access password entered

### 7.2 SELECTING THE SUB-MENUS

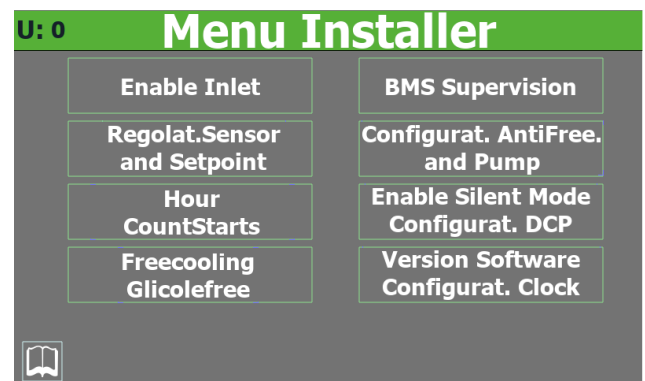

1. Indicates to which compressor the displayed data refers (U:1 = Master; U:2 = Slave 1; U:3 = Slave 2; U:4 = Slave 3)
2. Input Enable:  
This key is used to access the "Input enabling" sub-menu
3. Probe Regulation:  
This key is used to access the "Probe adjustment and set-point" sub-menu
4. Hour counters:  
This key is used to access the "Hour-counter and Peak-counter" sub-menu
5. Freecooling - Glycol Free:  
This key is used to access the "Free-cooling (glycol-free)" sub-menu
6. BMS Supervision:  
This key is used to access the "BMS supervision" sub-menu
7. Antifreeze Configuration:  
This key is used to access the "Antifreeze and pump configuration" sub-menu
8. Enable Silent Mode/Configure DCP:  
This key allows access to the Configure DCP and enable Silent Mode submenu
9. Software version/clock configuration:  
This key is used to access the "Software version and clock configuration" sub-menu

### 7.3 ENABLES INPUT FILTERS AND COMPRESSORS

**U: 0 Input Enable**

Filter Inlet	
Enable	NO
Analogs	9 s
Digitals	9 s
Enable Compressors	
C1	NO
C2	NO
C3	NO
C4	NO
In.Analog.Inverter	
P.Aspirat.	99.9 bar
P.Deliv.	99.9 bar

- Indicates to which compressor the displayed data refers (U:1 = Master; U:2 = Slave 1; U:3 = Slave 2; U:4 = Slave 3)
- indicates the actual setting relating to the enabling of the delay to read the analogue and digital inputs of the pCO<sub>2</sub> board (YES = filters enabled; NO = filters not enabled)
- Indicates the value assigned to the delay in reading the analogue inputs of the pCO<sub>2</sub> board
- Indicates the value assigned to the delay in reading the digital inputs of the pCO<sub>2</sub> board
- Indicates the actual setting relating to the enabling (only from the master window U:1) of compressor 1 (YES= compressor enabled; NO = compressor not enabled)
- Indicates the actual setting relating to the enabling (only from the master window U:1) of compressor 2 (YES= compressor enabled; NO = compressor not enabled)
- Indicates the actual setting relating to the enabling (only from the master window U:1) of compressor 3 (YES= compressor enabled; NO = compressor not enabled)
- Indicates the actual setting relating to the enabling (only from the master window U:1) of compressor 4 (YES= compressor enabled; NO = compressor not enabled)
- Indicates the actual pressure value read at compressor intake
- Indicates the actual pressure value read at compressor flow

### 7.4 ENABLING AND SETTING CONTROL VIA THE REMOTE SUPERVISOR (BMS)

**U: 0 BMS - Supervisor**

Serial Command On/Off	NO
Serial Command F/C	NO
Remote Command On/Off	NO
Remote Command F/C	NO
BMS1:	
Serial Address:	1
Baud rate:	1200 (RS485/RS422)
Serial Protocol:	Modbus Ext.
BMS2:	
Serial Address:	1
Baud rate:	1200 (RS485/RS422)
Serial Protocol:	Modbus Ext.

- Indicates to which compressor the displayed data refers (U:1 = Master; U:2 = Slave 1; U:3 = Slave 2; U:4 = Slave 3)
- Indicates the current setting for ON/OFF via the supervisor (YES = function enabled; NO = function disabled)
- Indicates, only on heat pumps, the actual setting for the changeover from supervisor (YES= function enabled; NO = function disabled)
- Indicates the actual setting for the ON/OFF from digital input ID1 (YES= function enabled; NO = function disabled)
- Indicates, only on heat pumps, the actual setting for the changeover from digital input ID2 (YES= function enabled; NO = function disabled)
- Indicates the current address assigned to the unit for communicating with the remote supervisor BMS1
- Indicates the actual value assigned to the communication speed between the unit and the BMS1 supervision system; the values that can be set are: 1200 or 19200 Baud
- It can indicate (if the appropriate accessory serial interface board is provided and properly installed) the actual protocol selected for communication between unit and BMS; the protocols available are:

Modbus RTU Slave = RS485 modbus supervisor;  
 CarelRS485 = communication protocol to pilot the expansion boards;  
 Bacnet = bacnet supervisor;  
 Lonworks = communication protocol to pilot the Lon expansion boards;

- Indicates the current address assigned to the unit for communicating with the remote supervisor BMS2
- Indicates the actual value assigned to the communication speed between the unit and the BMS2 supervision system; the values that can be set are: 1200 or 19200 Baud
- Display only parameter, indicates the communication protocol for the Slave compressors

### 7.5 OFFSET CONFIGURATION ON ANALOGUE INPUTS

**U: 0 Reg.Sensor and Setpoint**

Sensor Temperature Corrections			
B3	-9.9	B7	-9.9
B4	-9.9	B8	0.0
B5	-9.9	B9	0.0
B6	-9.9	B10	0.0
Correct.Sensor Temp.Expans.			
B1	-9.9	B3	-9.9
B2	-9.9	B4	-9.9
Condens.Set Actual			
Setpoint		99.9 bar	
Differential		99.9 bar	
Subcooling		-99.9 °C	

1. Indicates to which compressor the displayed data refers (U:1 = Master; U:2 = Slave 1; U:3 = Slave 2; U:4 = Slave 3)
2. Indicates the actual value to be added (or subtracted in case of negative values) as offset to the value read by the inlet water probe (if displaying the U:1 master page) or the evaporator water outlet (if displaying the Slave U:2, 3, 4 pages)
3. Indicates the actual value to be added (or subtracted in case of negative values) as offset to the value read by the probe placed at compressor flow
4. Indicates the actual value to be added (or subtracted in case of negative values) as offset to the value read by the evaporator outlet probe
5. Indicates the actual value to be added (or subtracted in case of negative values) as offset to the value read by the amperometric transformer
6. Indicates the actual value to be added (or subtracted in case of negative values) as offset to the value read by the multi-function input (if displaying the U:1 master page) or the recovery outlet (if displaying the Slave U:2, 3, 4 pages)
7. Indicates the actual value to be added (or subtracted in case of negative values) as offset to the value read by the outside air probe
8. Indicates the actual value to be added (or subtracted in case of negative values) as offset to the value read by the temperature probe on the evaporator gas side (only for units with recovery or freecooling)
9. Indicates the actual value to be added (or subtracted in case of negative values) as offset to the value read by the liquid temperature probe (only for units with recovery or freecooling)
10. Indicates the actual value to be added (or subtracted in case of negative values) as offset to the value read by the recovery inlet water probe (for version with recovery) or freecooling coil input (for freecooling units)
11. Indicates the actual value to be added (or subtracted in case of negative values) as offset to the value read by the recovery outlet water probe (for version with recovery) or freecooling coil output (for freecooling units)
12. Indicates the actual value to be added (or subtracted in case of negative values) as offset to the value read by the probe placed at intermediate heat exchanger input (freecooling versions)
13. Not used
14. Indicates the actual set value for adjusting the condensation pressure calculated according to the outside temperature
15. Indicates the differential applied to the actual set for adjusting the condensation pressure
16. Indicates the actual set for subcooling

## 7.6 CONFIGURING THE ANTIFREEZE CONDITIONS

**U: 0 Config. Antifr.and Pump**

Antifreeze Fan	NO	Alarm Antifreeze	
Temp.Ext.	-99.9 °C	Setpoint	0.0 °C
Off time	0 m	Differential	-99.9 °C
On time	0 s	Antifreeze Heater	
Alarm Antifreeze Gas		Setpoint	-99.9 °C
Output Evap.		Differential	-99.9 °C
Setpoint	0.0 °C	Pump	No
Differential	-99.9 °C		
Antifreeze Condens.			
Setpoint	0.0 °C		
Differential	0.0 °C		



1. Indicates to which compressor the displayed data refers (U:1 = Master; U:2 = Slave 1; U:3 = Slave 2; U:4 = Slave 3)
2. This value is used to choose whether to activate the cyclic fan activation function on the basis of the outside temperature. This prevents the accumulation of snow in the fans, and therefore the risk of ice formation, if the outside temperature falls very low (YES = cyclic fan activation enabled; NO = cyclic fan activation not enabled)
3. Indicates the outside air temperature below which cyclic fan activation is launched (if cyclic fan activation is enabled)
4. Indicates the time gap between two consecutive fan switch-on operations (if cyclic fan activation is enabled)
5. Indicates the duration of the fan cycle (if cyclic fan activation is enabled)
6. Indicates the temperature read on the evaporator outlet gas side, below which the evaporator gas side anti-freeze alarm activates
7. Indicates the differential to be applied to the evaporator outlet gas side temperature to exit the relative anti-freeze alarm
8. Setpoint antifreeze condensator: not used
9. Differential antifreeze condensator: not used
10. Indicates the temperature value for thermostat control (evaporator inlet or outlet), below which the antifreeze alarm is activated
11. Indicates the value of the differential, to be added to the inlet temperature on the recovery tank (if installed), for quitting the recovery antifreeze alarm condition
12. Indicates the heat exchanger water outlet temperature value, below which the anti-freeze resistance is activated
13. Indicates the heat exchanger water outlet temperature value, above which the anti-freeze resistance is deactivated
14. This value allows deciding whether to activate the pump with the anti-freeze resistance (YES= pump on with anti-freeze resistance; NO = pump not on with anti-freeze resistance)

## 7.7 PUMP AND COMPRESSOR FUNCTIONING LOG

**U: 0 Hourm.and Starts**

Hours Function.		Pump Evap.Hours Funct.	
Pump Evap.	999999	Warning	999 x1000
Pump Cond.	999999	Reset	NO 999999
Compressor	999999		
Pump Condens.Hours Funct.			
Warning	999 x1000		
Reset	NO 999999		
Compressor Hours Funct.			
Warning	999 x1000		
Reset	YES 999999		



1. Indicates to which compressor the displayed data refers (U:1 = Master; U:2 = Slave 1; U:3 = Slave 2; U:4 = Slave 3)
2. Indicates the number of hours during which the evaporator pump has been operated
3. Not used
4. Indicates the number of hours during which the currently selected compressor has been operated
5. Not used
6. Not used
7. Indicates the number of hours beyond which a maintenance alarm is generated for the currently selected compressor; this number is then multiplied by 1000, so if you want to set 2000 hours as threshold, enter 2 as value

8. Allows resetting the current hours of work counted for the currently selected compressor
9. Indicates the number of hours beyond which a maintenance alarm is generated for the evaporator pump; this number is then multiplied by 1000, so if you want to set 2000 hours as threshold, enter 2 as value
10. Allows resetting the current hours of work counted for the pump on the evaporator

## 7.8 DCP SETTINGS OR INVERTER FANS

**U: 0 Enable Silent Mode - Config.DCP**

Enable Timezone Night Silent Mode NO

Max Speed DCP on Night Silent Mode

Cool	10.0V		
Freecooling	10.0V		

Speed Max DCP		Regulation DCP	
Cool	10.0V	Min. Speed	0.0 V
Heat	10.0V	Start Time	0 s
Freecooling	10.0V		



1. Indicates to which compressor the displayed data refers (U:1 = Master; U:2 = Slave 1; U:3 = Slave 2; U:4 = Slave 3)
2. This value allows deciding whether to activate the night-time silenced functioning; this function is not available on silenced units. Also, for it to be activated, the unit must have inverter fans or be equipped with DCP; (YES = function active; NO = function not active)
3. Indicates the value in Volts to be assigned to the maximum fan speed during the night-time silencing function. This value can range from 0 to 10V, where 10V is the maximum speed available for the fans
4. Indicates the value in Volts to be assigned to the maximum fan speed (during the freecooling functioning mode) during the night-time silencing function. This value can range from 0 to 10V, where 10V is the maximum speed available for the fans
5. Heat: Not used
6. Indicates the value in Volts to be assigned to the maximum fan speed during the normal freecooling functioning. This value can range from 0 to 10V, where 10V is the maximum speed available for the fans
7. Indicates the value in Volts to be assigned to the maximum fan speed during the normal functioning. This value can range from 0 to 10V, where 10V is the maximum speed available for the fans
8. Indicates the value in Volts to be assigned to the minimum fan speed during the normal functioning. This value can range from 0 to 10V, where 0V is the minimum speed available for the fans
9. Indicates the time for which to maintain the peak on fan start-up (during the normal functioning of the fans)

## 7.9 ENABLINGS FREECOOLING GLICOLE FREE

**U: 0 Freecooling - Glicole Free**

Enable Freecooling	YES
Enable Glicole Free	NO



- Indicates to which compressor the displayed data refers (U:1 = Master; U:2 = Slave 1; U:3 = Slave 2; U:4 = Slave 3)
- This value allows deciding whether to activate or deactivate the freecooling mode, for the models provided with it (YES =freecooling active; NO = freecooling not active)
- This value allows deciding whether to activate or deactivate the glycol free freecooling mode, for the models provided with it (YES =freecooling active; NO = freecooling not active)

## 7.10 SETTINGS FREE GLYCOL FREECOOLING

U: 0 Freecooling - Glicole Free			
Pot Freecool 1	0 KW	Potenza Cp1	0 KW
Pot Freecool 2	0 KW	Potenza Cp2	0 KW
Pot Freecool 3	0 KW	Potenza Cp3	0 KW
Pot Freecool 4	0 KW	Potenza Cp4	0 KW
Delta T. FC1	15,0 °C	Set Mv FC	0,0 °C
Delta T. FC2	15,0 °C	Diff. Mv FC	0,0 °C
Delta T. FC3	15,0 °C	Time force FC	0 s
Delta T. FC4	15,0 °C	Antifreeze FC	-99,9 °C

- Indicates to which compressor the displayed data refers (U:1 = Master; U:2 = Slave 1; U:3 = Slave 2; U:4 = Slave 3)
- Indicates the value in kW declared for freecooling (circuit 1)
- Indicates the value in kW declared for freecooling (circuit 2)
- Indicates the value in kW declared for freecooling (circuit 3)
- Indicates the value in kW declared for freecooling (circuit 4)
- Indicates the value of compressor 1 in kW
- Indicates the value of compressor 2 in kW
- Indicates the value of compressor 3 in kW
- Indicates the value of compressor 4 in kW
- Indicates the differential between the outside air and the water temperature at unit inlet at which the freecooling power on circuit 1 is declared
- Indicates the differential between the outside air and the water temperature at unit inlet at which the freecooling power on circuit 2 is declared
- Indicates the differential between the outside air and the water temperature at unit inlet at which the freecooling power on circuit 3 is declared
- Indicates the differential between the outside air and the water temperature at unit inlet at which the freecooling power on circuit 4 is declared
- Indicates the outlet temperature from the freecooling coil below which the fans are inhibited
- Indicates the differential (applied to the freecooling coil output) beyond which the fans are enabled at maximum speed
- Indicates the forcing time for the glycol pump at start-up
- Indicates the activation set of the anti-freeze resistance for the glycol side

## 7.12 SOFTWARE VERSION

U: 0 Version Software	
Aermec	
Screw	
Cod.: NSMI	
Ver.:1.0.1 10/12/16	

- Indicates to which compressor the displayed data refers (U:1 = Master; U:2 = Slave 1; U:3 = Slave 2; U:4 = Slave 3)
- Indicates the current software version for the pCO5 card

## 7.11 DATE AND TIME SETTINGS ON THE MAIN BOARD AND ON THE TOUCH DISPLAY BOARD

U: 0 Configuration Clock	
Clock Panel Touch	Clock Board pCO5+
Monday	Current Hour
00 : 00 : 00	Sunday
00 / 00 / 0000	00 : 00
	00 / 00 / 2000
	Modificat.Hour - Date
	Sunday
	00 : 00
	00 / 00 / 2000
	Modif.Clock of Sched.

- Indicates to which compressor the displayed data refers (U:1 = Master; U:2 = Slave 1; U:3 = Slave 2; U:4 = Slave 3)
- Indicates the current day of the week on the touch display board timer
- Indicates the current time on the touch display board timer
- Indicates the current date on the touch display board timer
- Indicates the current time on the pCO5 timer
- Indicates the current date on the pCO5 timer
- Indicates the time to set on the pCO5 timer
- Indicates the date to set on the pCO5 timer
- Allows setting the specified date and time on the pCO5 board

## 8 ALARM MENU

The ALARM menu is used to view (and reset, if necessary) the alarm conditions that may arise on the unit while it's working. The alarms are divided into various categories according to their seriousness. Remember that some of them can cause serious damage to the unit so, before performing a reset, it's important to be sure about the nature of the alarm and the reason it was triggered (contacting specialised technical personnel if necessary).

■ **NOTE:** The top-left corner of each window shows which compressor is currently providing the displayed data (U:1,2,3 o 4); to switch between compressors (only possible from Master unit), refer to that explained in paragraph "3.3 Unit operating status information (real time data) p. 7".

### 8.1 MAIN ALARM PAGE

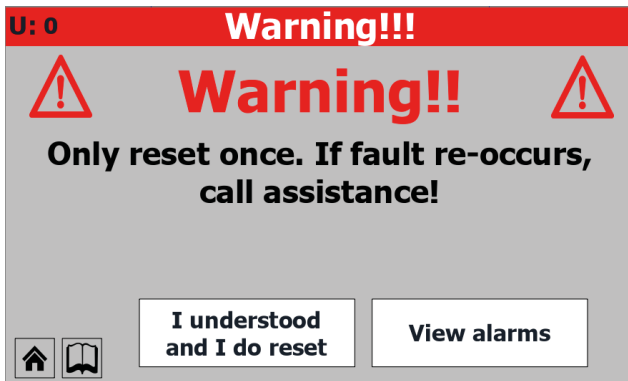

- Indicates to which compressor the displayed data refers (U:1 = Master; U:2 = Slave 1; U:3 = Slave 2; U:4 = Slave 3)
- Indicates the number of alarms currently active on the unit.

### 8.2 ACTIVE ALARMS PAGE

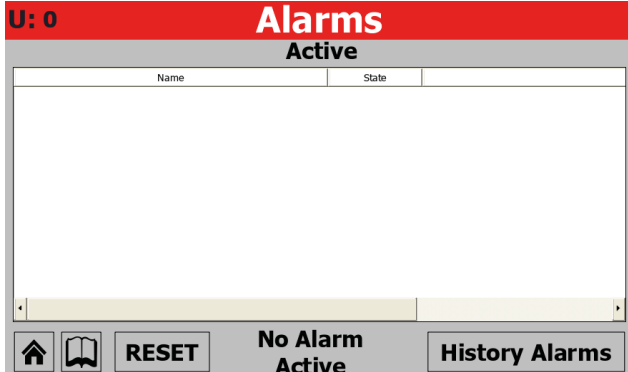

- Indicates to which compressor the displayed data refers (U:1 = Master; U:2 = Slave 1; U:3 = Slave 2; U:4 = Slave 3)
- Indicates the alarms currently active on the unit providing some information on the nature of the alarm

### 8.3 ALARM HISTORY

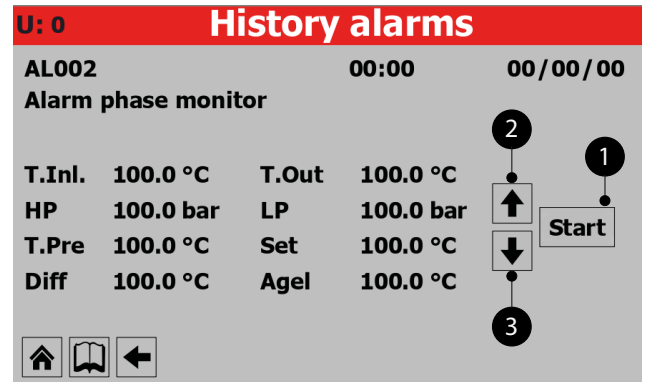

- Indicates to which compressor the displayed data refers (U:1 = Master; U:2 = Slave 1; U:3 = Slave 2; U:4 = Slave 3)
  - Indicates the time and date when the alarm was triggered
  - Indicates the alarm ID code
  - Indicates the short description of the alarm
  - Indicates the temperature of the water entering the heat exchanger at the time of the alarm
  - Indicates the temperature of the water leaving the heat exchanger at the time of the alarm
  - Indicates the high pressure at the time of the alarm
  - Indicates the low pressure at the time of the alarm
  - Indicates the temperature on the pressing line at the time of the alarm
  - Indicates the setpoint value at the time of the alarm
  - Indicates the differential value at the time of the alarm
  - Indicates the anti-freeze setpoint value at the time of the alarm
1. Used to go to the first alarm in the alarm log
  2. Used to go back to the previous alarm in the alarm log
  3. Used to move on to the next alarm in the alarm log

## 8.4 LIST OF ALARMS

Table of contents	Meaning	Note
AL01	Alarm with automatic reset	
AL02	Phase/voltage warning alarm	
AL03	Anti-freeze alarm	
AL04	Compressor circuit breaker alarm	
AL05	Flow meter alarm	
AL07	Oil pressure switch alarm	
AL08	Differential pressure alarm	
AL09	High pressure alarm (pressure switch)	
AL10	High pressure alarm (transducer)	
AL11	Low pressure alarm (pressure switch)	
AL12	Low pressure alarm (transducer)	
AL13	High pressing line gas temperature alarm	
AL14	Fan 1 circuit breaker alarm	
AL16	Condenser pump circuit breaker alarm	
AL17	Evaporator pump circuit breaker alarm	
AL20	Evaporator pump maintenance alarm	
AL21	Condenser pump maintenance alarm	
AL22	Compressor maintenance alarm	
AL31	B1 probe faulty or disconnected alarm	
AL32	B2 probe faulty or disconnected alarm	
AL33	B3 probe faulty or disconnected alarm	
AL34	B4 probe faulty or disconnected alarm	
AL35	B5 probe faulty or disconnected alarm	
AL36	B6 probe faulty or disconnected alarm	
AL37	B7 probe faulty or disconnected alarm	
AL38	B8 probe faulty or disconnected alarm	
AL39	B9 probe faulty or disconnected alarm	
AL40	B10 probe faulty or disconnected alarm	
AL41	Expansion B1 probe faulty or not connected alarm	
AL42	Expansion B2 probe faulty or not connected alarm	
AL43	Expansion faulty or not connected alarm	
AL44	Anti-freeze alarm from digital input	
AL45	Capacity decrease relay alarm	
AL46	Capacity increase relay alarm	
AL47	Amperometric transformer alarm	
AL48	Expansion B3 probe faulty or not connected alarm	
AL49	Expansion B4 probe faulty or not connected alarm	
AL50	Freecooling flow meter alarm	It is not an alarm
AL51	Freecooling pump circuit breaker alarm	
AL75	Evaporator gas output anti-freeze alarm	
AL80	Condenser filter alarm	
AL85	Transducer LOW pressure alarm	
AL90	Anti-freeze probe alarm	
AL91	Condenser flow meter alarm	
AL92	Condenser anti-freeze alarm	
AL93	EEV driver battery alarm	
AL100	Inverter Envelope fault init alarm	
AL101	Inverter fault alarm	
AL102	Inverter Overcurrent alarm	
AL103	Inverter Overvoltage alarm	
AL104	Inverter Overtemperature alarm	
AL105	Allarme Inverter Undervoltage	
AL106	Inverter Mains failure alarm	
AL107	Inverter HW fault alarm	
AL108	Inverter Temperature sensor fault	
AL109	Inverter HW configuration fault alarm	
AL110	Inverter configuration data fault alarm	
AL111	Inverter parameter configuration fault alarm	
AL112	Inverter motor thermal overload alarm	
AL113	Motoroverload alarm	
AL115	Inverter missing motor phase alarm	
AL116	Inverter High oil temperature alarm	
AL117	Inverter Low oil level alarm	
AL118	Inverter compressor short cycling alarm	
AL119	Inverter Envelope fault alarm	
AL120	Inverter serial control timeout alarm	
AL121	Inverter Communication fault alarm	
AL122	Inverter Pressure Alarm	
AL123	Inverter Datalog Error	

## 9 DIAGRAM MENU

The CHART menu is used to view certain unit operating parameters, shown graphically on Cartesian axes to illustrate the value changes (temperature, power or pressure) requested over time.

### 9.1 CHART SHOWING TEMPERATURE TREND OF INLET/OUTLET WATER ON HEAT EXCHANGER

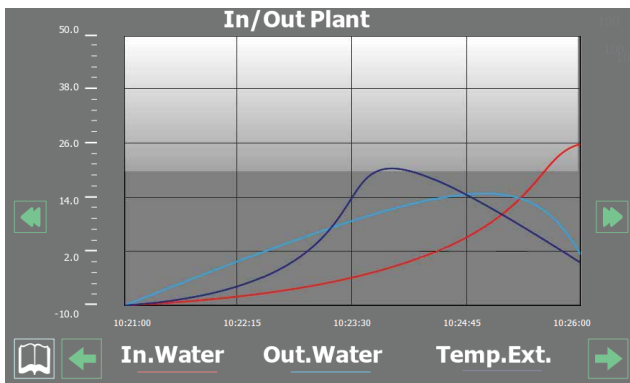

Displays a chart in real time, relating to the temperature of the water entering and leaving the heat exchanger (in the lower part you can see a key explaining the colours of the curves).

### 9.2 CONDENSER (WATER/WATER UNIT) INLET/OUTLET WATER TEMPERATURE TREND CHART

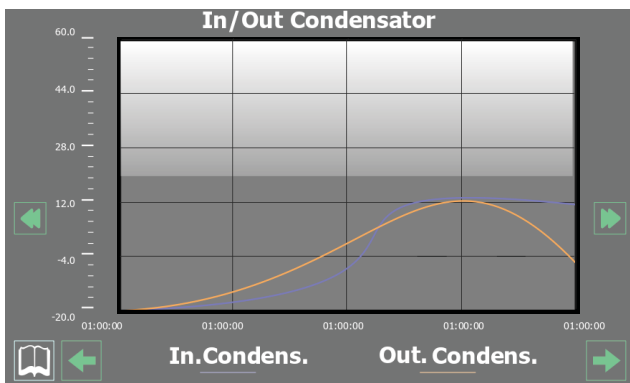

Displays a chart in real time, relating to the temperature of the water entering and leaving the heat exchanger (in the lower part you can see a key explaining the colours of the curves).

### 9.3 COMPRESSOR TREND CHART

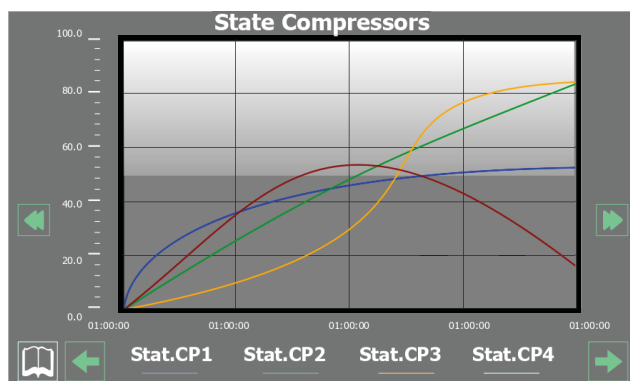

Displays a real-time chart on the trend of the compressor powers (the key for the colours of the curves is shown on the bottom)

### 9.4 HIGH AND LOW PRESSURE TREND CHART

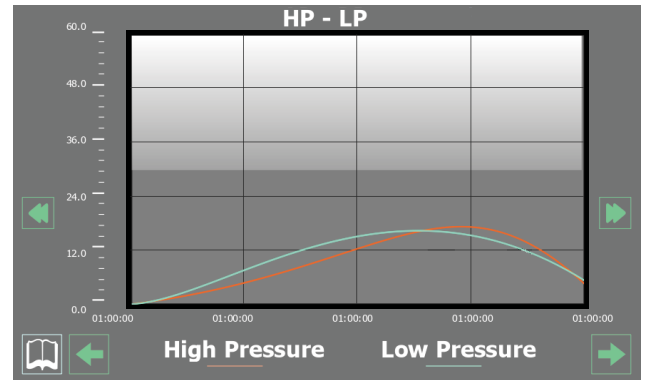

Displays a real-time chart on the trend of high and low pressures (the key for the colours of the curves is shown on the bottom)

## 10 SUMMARY MENU

The SUMMARY menu provides a simplified representation of the unit with a selection of the operating parameters (in real time), on the basis of the feedback from the various probes installed.

NOTE: The top-left corner of each window shows which compressor is currently providing the displayed data (U:1,2,3 o 4); to switch between compressors (only possible from Master unit), refer to that explained in paragraph "3.3 Unit operating status information (real time data) p. 7".

### 10.1 PAGE RELATING TO THE COOLING ONLY UNITS

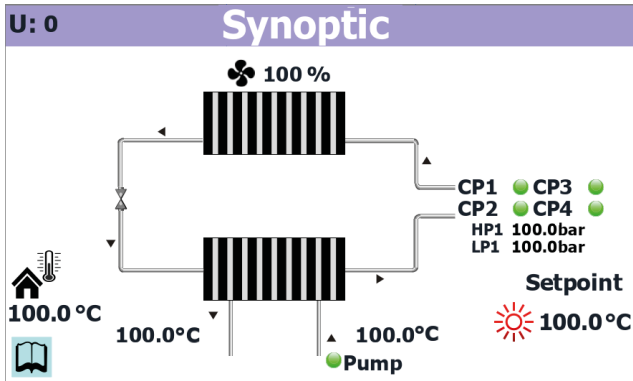

- Indicates to which compressor the displayed data refers (U:1 = Master; U:2 = Slave 1; U:3 = Slave 2; U:4 = Slave 3)
- Indicates the actual speed of the fans
- Indicates the current outside temperature
- Indicates the status of the pump (if it's active, the relative label is displayed) and the temperature of the water entering the heat exchanger
- Indicates the current operating set-point for the unit
- Indicates the actual status of the compressors (those displayed are the currently active compressors, if no compressor is "On" no label will be displayed)
- Indicates the actual high pressure value for the currently selected circuit
- Indicates the actual low pressure value for the currently selected circuit
- Indicates the temperature of the water leaving the heat exchanger
- Indicates the heat exchanger inlet water temperature

### 10.2 PAGE RELATING TO THE UNITS WITH FREECOOLING

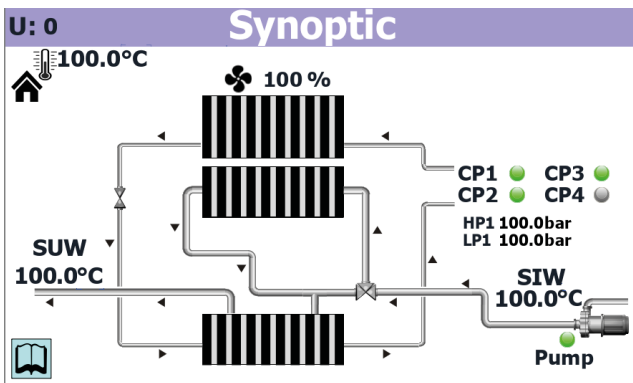

- Indicates to which compressor the displayed data refers (U:1 = Master; U:2 = Slave 1; U:3 = Slave 2; U:4 = Slave 3)
- Indicates the current outside temperature
- Indicates the temperature of the water leaving the heat exchanger
- Indicates the actual speed of the fans
- Indicates the actual status of the compressors (those displayed are the currently active compressors, if no compressor is "On" no label will be displayed)
- Indicates the actual high pressure value for the currently selected circuit
- Indicates the actual low pressure value for the currently selected circuit
- Indicates the heat exchanger inlet water temperature
- Indicates the status of the pump (if it's active, the relative label is displayed)

### 10.3 PAGE RELATING TO THE UNITS WITH FREE GLYCOL FREECOOLING

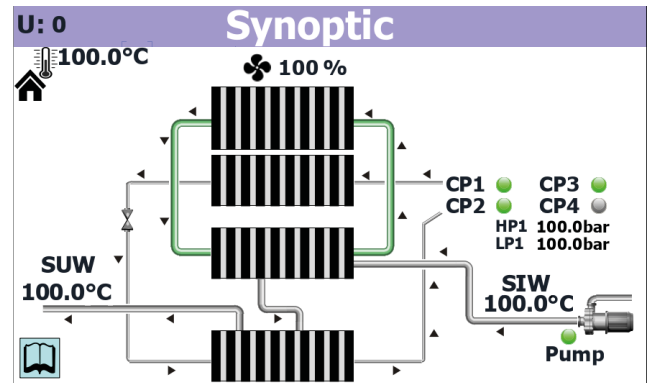

- Indicates to which compressor the displayed data refers (U:1 = Master; U:2 = Slave 1; U:3 = Slave 2; U:4 = Slave 3)
- Indicates the current outside temperature
- Indicates the temperature of the water leaving the heat exchanger
- Indicates the actual speed of the fans
- Indicates the actual status of the compressors (those displayed are the currently active compressors, if no compressor is "On" no label will be displayed)
- Indicates the actual high pressure value for the currently selected circuit
- Indicates the actual low pressure value for the currently selected circuit
- Indicates the heat exchanger inlet water temperature
- Indicates the status of the pump (if it's active, the relative label is displayed)

### 10.4 PAGE RELATING TO THE UNITS WITH RECOVERY

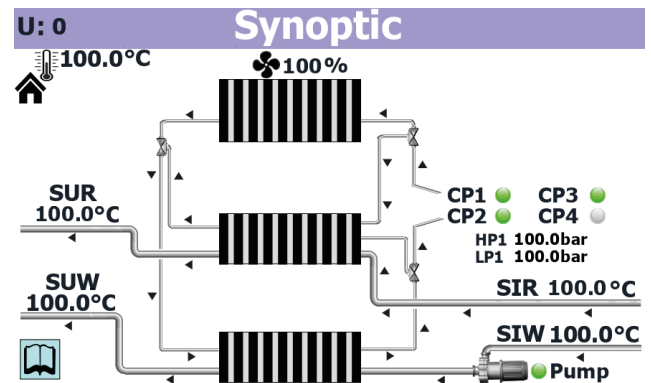

- Indicates to which compressor the displayed data refers (U:1 = Master; U:2 = Slave 1; U:3 = Slave 2; U:4 = Slave 3)
- Indicates the current outside temperature
- Indicates the water temperature from the recovery outlet
- Indicates the temperature of the water leaving the heat exchanger
- Indicates the actual speed of the fans
- Indicates the actual status of the compressors (those displayed are the currently active compressors, if no compressor is "On" no label will be displayed)
- Indicates the actual high pressure value for the currently selected circuit
- Indicates the actual low pressure value for the currently selected circuit
- Indicates the water temperature at the recovery inlet
- Indicates the heat exchanger inlet water temperature
- Indicates the status of the pump (if it's active, the relative label is displayed)

## 11 TIME BAND MENU

With the TIME PERIODS menu you can set the time periods to be used in the hourly programming of the unit.

■ **NOTE:** The top-left corner of each window shows which compressor is currently providing the displayed data (U:1,2,3 o 4); to switch between compressors (only possible from Master unit), refer to that explained in paragraph "3.3 Unit operating status information (real time data) p. 7".

### 11.1 PAGE FOR CREATING TIMED PROGRAMS

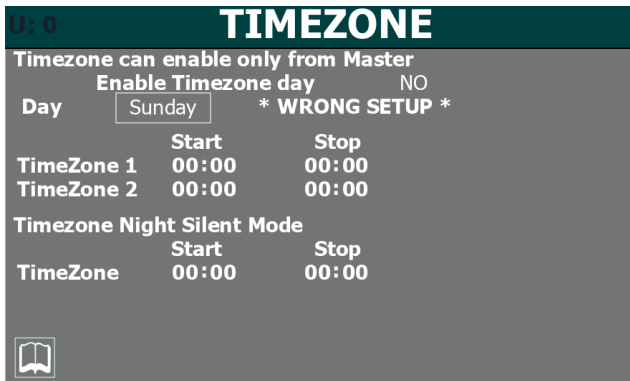

- Indicates to which compressor the displayed data refers (U:1 = Master; U:2 = Slave 1; U:3 = Slave 2; U:4 = Slave 3)
- Allows deciding whether to enable or not the time periods (YES = enabled; NO = not enabled)
- Indicates which day the visualised time settings apply to
- Allows establishing the start time of the first available time period
- Allows establishing the end time of the first available time period
- Allows establishing the start time of the second available time period
- Allows establishing the end time of the second available time period
- Allows establishing the start time of the time period for the Night Silent function (7.8 DCP Settings or inverter fans p. 13)
- Allows establishing the end time of the time period for the Night Silent function (7.8 DCP Settings or inverter fans p. 13)

## 12 LANGUAGE MENU

The LANGUAGE menu is used to modify the interface language for the various menus. The system language is usually set in the factory, according to the country where the unit will be used, but it can be altered at any time via this menu.

### 12.1 PAGE FOR SELECTING THE SYSTEM LANGUAGE

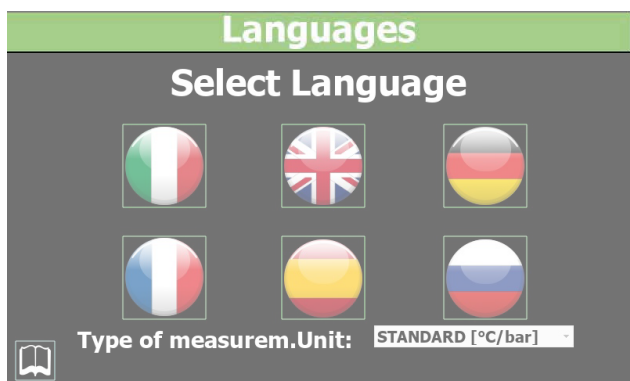

- Used to set Italian as the system language
- Used to set English as the system language
- Used to set German as the system language
- Used to set French as the system language
- Used to set Spanish as the system language

## 13 HELP MENU

Menu protected and blocked by a password.



**WARNING:** this menu contains parameters that may cause malfunctioning if they are incorrectly set. For this reason, only technical maintenance personnel or other authorised personnel may access this menu. For more information, contact After Sales Service.

## 14 MULTI-PURPOSE INPUT MENU

With the MULTI-FUNCTION INPUT menu you can set the function to be assigned to multi-function input U7 (MASTER).

### 14.1 DISPLAYS THE STATUS OF MULTI-FUNCTION INPUT U7

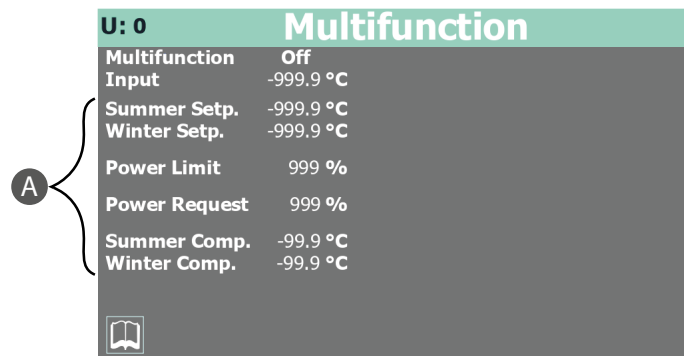

- Indicates to which compressor the displayed data refers (U:1 = Master; U:2 = Slave 1; U:3 = Slave 2; U:4 = Slave 3)
- Indicates whether the multi-function input has been enabled or not (this enabling can only be set by the after-sales assistance personnel)
- Indicates the value read on analogue input U7 (this enabling can only be set by the after-sales assistance personnel)

**A.** Value reserved for after-sales assistance

SCARICA L'ULTIMA VERSIONE:

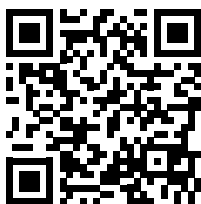

<http://www.aermec.com/qrcode.asp?q=5593>

DOWNLOAD THE LATEST VERSION:

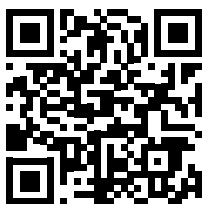

<http://www.aermec.com/qrcode.asp?q=5589>

TÉLÉCHARGER LA DERNIÈRE VERSION:



<http://www.aermec.com/qrcode.asp?q=15638>



Aermec S.p.A.

Via Roma, 996 - 37040 Bevilacqua (VR) - Italia

Tel. +39 0442 633 111 - Fax +39 0442 93577

marketing@aermec.com - www.aermec.com

BITTE LADEN SIE DIE LETZTE VERSION  
HERUNTER:

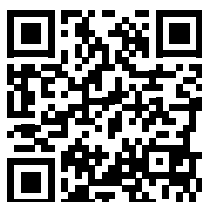

<http://www.aermec.com/qrcode.asp?q=15639>

DESCARGUE LA ÚLTIMA VERSIÓN:

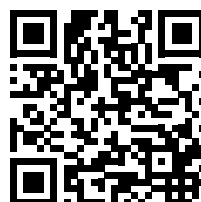

<http://www.aermec.com/qrcode.asp?q=15640>