

Operating manual ST101



Control Box ST101



Display ST501F



Button 1: UP

This button increases a set or parameter value selected with the SET buttons, or selects the next parameter in the parameter list. Hold the button for 3 seconds to activate defrosting at any time.



Button 2: DOWN

This button reduces a set or parameter value selected with the SET buttons, or selects the previous parameter in the parameter list.



Button 3: SET temperature

This button displays a set or parameter value, which is then adjusted in combination with the "UP" or "DOWN" button.



Button 4: SET time

Press this button briefly to see the current time for a few seconds. Hold the button (approx. 3 seconds) to adjust the date and time.



Button 5: ACK Alarm

Press this button to acknowledge the alarm signals. Press this button simultaneously with button 3 (SET) to see the current battery voltage.



Button 6: On/Off

Press this button to switch the controller into standby mode. Press the button once more to switch on again. This button also starts the compressor motor again if it was switched off with the input signal "E3" (see parameter P16).

Selecting parameter levels:

Depending on the device connected, a various number of parameter levels are accessible ("PA0" - "PA9"). The "UP" and "DOWN" buttons must be pressed simultaneously for around 3s for the controller to go to the level selection ("PA0" appears). The desired level can be selected using "UP" or "DOWN". The "SET" button is used to enter this level. If a level is not protected by a password, "---" will appear in the display after the "SET" button has been pressed, and the user enters the level immediately after releasing the "SET" button. If the level is protected by password, a "0" appears in the display when the "SET" button is pressed (keep pressed!). The password can now be set by pressing the "UP" or "DOWN" buttons again. When the "SET" button is released, the unit goes to the level selected provided the password is entered correctly. If it is not entered correctly, the unit returns to the user level. A level is exited by pressing "UP" and "DOWN" simultaneously, or automatically if no buttons are pressed for about 10s. The levels "PA0" to "PA9" contain parameters that are stored in the respective control unit. A description of these parameters can be found there. The "PAL" level contains local settings that only apply for this display and are also stored here (this level is also accessible in the case of a "F90" fault). Parameters can also be set in standby mode. Regulation is not interrupted during parameter setting. A list and description can be found in the following tables:

The following parameter levels are realized in the control unit:

PA0 Operating level 1	Without password
PA1 Operating level 2	Password at the end of parameter list PA1
PA2 Operating level 3 (Service)	Password at the end of parameter list PA2
PAL Operating level 4 (control unit)	Password at the end of parameter list PAL

Reading out remaining running time:

Proceed as described under "Selecting parameter levels" and access level PA0. P0 will appear, press the arrow up button until P20 appears. Press the thermometer button and keep it pressed, register this value. Multiply the value shown by 10; this is the remaining running time in hours.

Resetting remaining running time:

After servicing and respective monitoring of all parameters using the latest parameter list, parameter P21 must be reset to the original value in programming mode PA2. Proceed as described under "Selecting parameter levels" and access level PA2. P15 will appear, press the arrow up button until P21 appears. Press the thermometer button and keep it pressed, then press the arrow up button until 150 appears, release the buttons. Press the thermometer button again to check the settings. Press both arrows at the same time until OFF appears. Switch the cooling system on. As soon as the fault code E6 appears again, press the bell button once. The remaining running time has now been extended to 1500 operating hours. The system will now run in normal operating mode.

Replacing the control unit:

Before the control unit can be replaced, the remaining running time must be read out and noted. Follow the steps described in "Reading out remaining running time". If this is not possible due to a faulty control unit, the value must be extrapolated on the basis of the vehicle mileage. Now disconnect the power supply and replace the control unit. After replacement, the parameters must be set according to the technical specifications. Parameter P21 on level PA2 is an exception to this rule. The readout value must be entered in parameter P21 during programming of the new control board. All other parameters must be taken over according to the parameter list. **Then the internal clock must be set.**

Internal clock setting

Press the key „Set time“ longer. Now you are in the program mode. The first value is the year. With the keys „UP“ or „DOWN“ this can be set. Then you briefly press the key „Set time“ and come to the next value, the month. After the adjustment confirm again with „Set time“. You continue this procedure and thus come by the values „day“, „hour“ and „minute“. With the last confirmation by the key „Set time“ you leave the program mode. In the LED's you can ascertain in which level you are, „y“, „m:d“ or „h:m“.

Status displays and fault codes

Code	Cause	Measure
E0	Fault on the cargo area sensor F1, break or short-circuit	Check the sensor
E1	Fault on the evaporator sensor F2, break or short-circuit	Check the sensor
E2	Fault on the electric motor sensor F3, break or short-circuit	Check the sensor
E4	On-board voltage too low	Check the generator, battery, relays and drop in voltage at contacts
E5	Electric motor on compressor too hot	Electric motor continues to run without compressor load and cools down
E6	Warning starts from 300 remaining hours. The system stops after 300 hours	Acknowledge with the bell button from 300 hours to 1 hour, after which the cooling system must be serviced.
E7	One of the cargo area doors is open	Close the door
E8	High-pressure problem	- Check the condenser fan - Soiling at the condenser - Too much refrigerant
E9	Low-pressure problem	- Check the parameter list - Not enough refrigerant
EP0	Internal fault on the control unit	Replace ST101
EP1	Fault in the parameter memory	Replace ST101
EP2	Fault in the data memory	Replace ST101
rtc	Internal time is zero	Set clock
U1x	Version display, e.g. V180 a. Once when current applied for the first time b. Permanently	a. - Goes out after about 3 sec. b. - Permanently low voltage - Control unit faulty
F90	Network fault	- Check addresses Lo0 and Lo1 - Interruption in the data cable
F91	Software in the control unit does not match the display	Ensure version status is the same
CrC	Internal fault	Replace display

The faults “EP0”, “EP1”, “EP2” and “rtc” are blocking the control unit. The control unit is only released when the fault has been eliminated. The faults “EP0” and “EP2” can only be eliminated by repairs. The faults E0 to E5, and E7 to E9 are displayed alternating with the current cargo room temperature. With warning code E6, this is displayed alternating with the current remaining running time. When the warning has been acknowledged by pressing the appropriate button, the cargo room temperature is displayed again. If there is no connection to a controller for 1 minute, the control unit switches off.

Operating manual XW370K

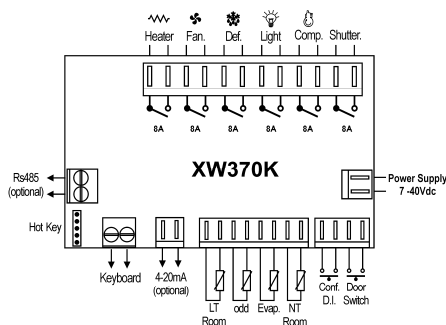

Control board XW370K



Display T630

Activating the controller

The control device can be activated through the ON/OFF button (blue button) on the controller, with a D+ signal present. There is also a memory function from version D onwards.

Checking and setting parameters

Put the cooling system into operation. You can enter the different parameter levels after 30 seconds. Proceed as follows.

Push the ▼ and then **set** buttons and keep pressed together for 3s (until "HY" appears on the display)

Use ▼ to select level PR2, then press **set**. PAS flashes for three seconds, then

"0 - -" appears and flashes. Enter the password, code 321 is used as an example. You will find the right code at the end of the respectively valid parameter list.

▲ Enter "3", then press 1x **set** button

▲ Enter "2", then press 1x **set** button

▲ Enter "1", then press 1x **set** button

Now "HY" appears again and parameter level 2 (PR2) is active. Set the parameters according to the technical data. By pressing the set button you will move from the parameter itself to the "parameter value", pressing the button again will lead you to the next parameter, according to the parameter list. Values can be changed using the arrow buttons. If no entries are made for 8 seconds, the control unit automatically returns to the user level.

Reading out remaining running time / service counter

Follow the "Checking and setting parameters" instructions given above. If the parameter "Hy" is displayed, press the arrow down button until the parameter "SCH" appears. Press the set button. The value displayed is the remaining running time in days. Note this value. The SCH parameter indicates the remaining running time until a service has to be carried out. After the value entered in parameter SH has expired, the code SER (service) appears on the display. This alternates (flashing) with the current room temperature. The "service" code can be acknowledged by pressing any button. When the controller is switched on again, the SER code reappears. The counter continues to count in the negative range. As soon as the service has been carried out and the counter has been acknowledged, the counter status is automatically reset to the original starting value, e.g. +999 hours.

Resetting remaining running time to specification "SH"



The service parameter SH provides the specification 0-999 units (decreasing). The activation (switch-on) of the control unit is taken as a reference parameter. The unit can be given in hours or days, and is specified through parameter "Stb". The resolution is 1 minute and is written into an intermediate memory. After this the values are transferred into a so-called final memory every 5 minutes, which you can view. If the vehicle is at a standstill and/or the control unit is switched off before the five minutes are up, the intermediate memory is deleted and no data is transferred to the final memory.

Follow the "Checking and setting parameters" instructions given above. If the parameter "Hy" is displayed, press the arrow down button until the parameter "SCH" appears. Press the Set button. The value displayed is the remaining running time in days. Note this value. While the value is displayed, press the arrow down button and keep it pressed until "rst" appears in the display. The value of parameter "SH" is now taken over. To check, recall the parameter "SCH" again.



Replacing the control board

This is the lower one of the two boards. Before the control board can be replaced, the remaining running time must be read out and noted. Follow the steps described in "Reading out remaining running time". If this is not possible due to a faulty control board, the value must be extrapolated on the basis of the vehicle mileage. Now disconnect the power supply and replace the control board. After replacement, the parameters must be set according to the technical specifications. The parameters "SH" and "SCH" are exceptions to this. The readout value must be entered in parameter "SH" during programming of the new control board. All other parameters must be taken over according to the parameter list. After all the parameters have been entered, follow the instructions "Resetting remaining running time to specification 'SH'", the controller now works with the correct remaining running time.

Changing the set point

- (a)  Press the button
- (b) Enter the required value using ▼ or ▲
- (c)  Confirmation of the new set point

Changing the specified values

- (a)  Press the button
- (b) Enter the required value using ▼ or ▲
- (c)  Confirmation of the new set point
- (d) The next parameter code is automatically displayed.
- (e) It is also possible to select the parameters directly. You can select these using buttons ▼ or ▲. Continue with a) etc.

Starting manual defrosting



Keep the button pressed for at least 3s.

Locking / Unlocking the keypad



1. Keep buttons ▲ and ▼ pressed for about 3s.
2. The code "PoF" is displayed for a few seconds and the keypad is locked. After this only the set point and the max./min. temperatures can be viewed. In addition, the light (light button affects the light relay) and control unit (ON/OFF button) can still be switched on and off.

Unlocking the keypad

Press the buttons UP and DOWN again for about 3s. The code "Pon" is displayed for a few seconds.

Viewing the measuring values

The measuring value of the control sensor (Pb1) is displayed as standard.

To request all measuring values, please proceed as follows:

1. Enter programming level "Pr2".
2. Use the button ▼ to select the parameter "Prd" (display sub-menu sensor measuring values Pb1, Pb2, etc.).
3. Press the "SET" button once to display the sensor value "Pb1".
4. Use the buttons ▼ or ▲ to select the further measuring value Pb2.
5. You can view the following measuring values by pressing the button "SET" on its own.

"Pr2" -> Parameter "Prd" -> Pb1, Pb2:

Pb1 = Cargo area sensor

Pb2 = Evaporator sensor

Alarm codes

Code	Cause	Outputs
"P1"	Cargo area sensor fault	Compressor according to parameter settings "Con" and "CoF"
"P2"	Evaporator sensor	Alarm output ACTIVE; regulation still active. Thawing takes place according to time set "MdF"
"dA"	Door open	Alarm output ACTIVE; specification according to "Odc".
"noL"	No link, display fault	Alarm output ACTIVE; regulation still active.
"PoF"	keypad locked	See chapter 4, button combinations
"Pon"	keypad unlocked	See chapter 4, button combinations
"EE"	Memory fault	Alarm output ACTIVE; regulation inactive.
"PAL"	Pressure control switch alarm	Alarm output ACTIVE; regulation continues to be active until the number of switching's in the parameter "nPS" exceeds the time set in the parameter "did".
"SEr"	Service interval expired	Service counter, see chapter 4

The alarm output, if present, is always activated in the event of an alarm. Alarm codes are indicated alternating with the room temperature, except "P1". "EE" can be acknowledged by pressing any button, "rSt" appears in the display for 3s, then the unit returns to normal operation.