

FUJII ELECTRIC

**SPLIT TYPE
ROOM AIR CONDITIONER**

CEILING type (50Hz)

SERVICE MANUAL

Models	Indoor unit	Outdoor unit
	RY-36EA	RO-36EP
	RY-45EA	RO-45EP



C O N T E N T S

SPECIFICATIONS	1
OUTLINE AND DIMENSIONS	3
REFRIGERANT SYSTEM DIAGRAM	5
CIRCUIT DIAGRAM	6
INDOOR P. C. BOARD CIRCUIT DIAGRAM	7
INDOOR P. C. BOARD LAYOUTS	8
REMOTE CONTROL UNIT CODE SWITCHING	10
DISASSEMBLY ILLUSTRATION	11
PARTS LIST	20

S P E C I F I C A T I O N S

TYPE	COOLING	
INDOOR UNIT	RY-36EA	RY-45EA
OUTDOOR UNIT	RO-36EP	RO-45EP
COOLING CAPACITY (kW)	10.3 - 10.5	12.4 - 12.7

ELECTRICAL DATA

POWER SOURCE	3N ~ 380 - 415V 50Hz	
RUNNING CURRENT (A)	7.0 - 6.9	8.6 - 8.8
INPUT WATTS (kW)	4.05 - 4.05	4.76 - 4.80
EER (kW/kW)	2.54 - 2.59	2.61 - 2.65
MOISTURE REMOVAL (ℓ/hr)	4.0	5.5
AIR CIRCULATION-Hi (m ³ /hr)	1,660	1,850

COMPRESSOR

TYPE	Hermetic type, 2 pole, 3-phase, Induction motor	
CODE	ZR49KCE-TFD	ZR61KCE-TFD
REFRIGERANT R407C (g)	2,300	3,400

FAN MOTOR

POWER SOURCE (V)	220 - 240	
INDOOR UNIT	TYPE	MFA-45DZM
	HI-SPEED (r.p.m.)	1,000
	MED-SPEED (r.p.m.)	900
	LO-SPEED (r.p.m.)	750
OUTDOOR UNIT	TYPE	MFB-362FT
	HI-SPEED (r.p.m.)	790
	LO-SPEED (r.p.m.)	—

DIMENSIONS

INDOOR UNIT	H x W x D (mm)	240 x 1,660 x 700
OUTDOOR UNIT		1,152 x 940 x 370

WEIGHTS

INDOOR UNIT	GROSS / NET (kg)	61 / 48
OUTDOOR UNIT		108 / 94

MODELS				RY-36EA	RY-45EA
				RO-36EP	RO-45EP
REFRIGERANT CIRCUIT	DISCHARGE PRESSURE	kg/cm ² G		21.5	21.5
	SUCTION PRESSURE			5.0	4.8
	DISCHARGE TEMP.	°C		85	80
	REFRIG. PIPE LENGTH	m		7.5	7.5
	DISCHARGE AIR TEMP.	°C		12	12
CONDITION	INDOOR ENTERING AIR TEMP.	DB/WB °C		27.0 / 19.0	
	OUTDOOR ENTERING AIR TEMP.	DB/WB °C		35.0 / 24.0	
PIPING	PIPE DIA. SIZE	LIQUID	mm	9.53	
		GAS		19.05	
	CONNECTION METHOD			Flare	
	BETWEEN	HEIGHT	m	Max. 30	
		PIPE LENGTH		Max. 50	

REFRIGERANT CHARGE

MODELS		PIPE LENGTH	10 m (33 ft)	20 m (66 ft)	30 m (99 ft)	40 m (132 ft)	50 m (164 ft)
		FULL CHARGE AMOUNT (R407C)	RY-36EA		2,300 g (81.1 oz)		2,600 g (91.7 oz)
RY-45EA			3,400 g (119.9 oz)		3,700 g (130.5 oz)	4,000 g (141.1 oz)	4,300 g (151.7 oz)

Note : Between 20 m and 50 m, when using a connection pipe other than that in the table, charge additional refrigerant with 30 g (1.06 oz) / 1 m (3.3 ft) as the criteria.

OUTLINE AND DIMENSIONS

Models : RY-36EA
RY-45EA

(Unit : mm)

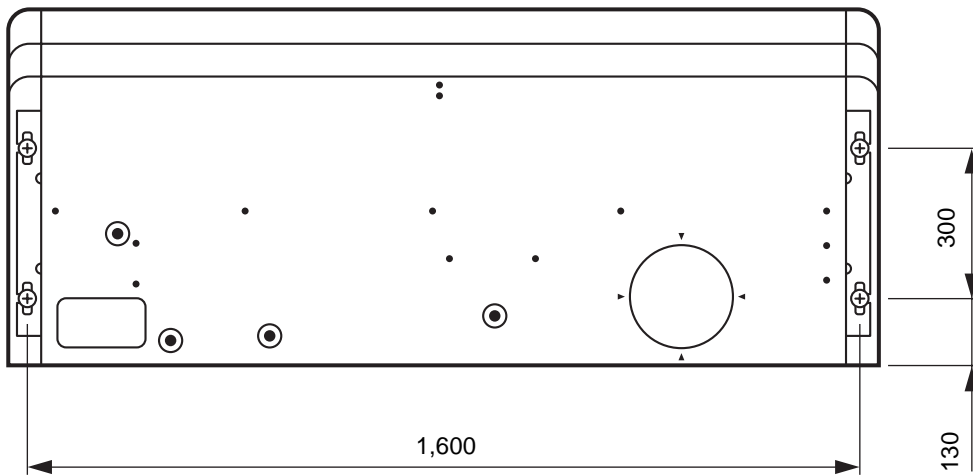
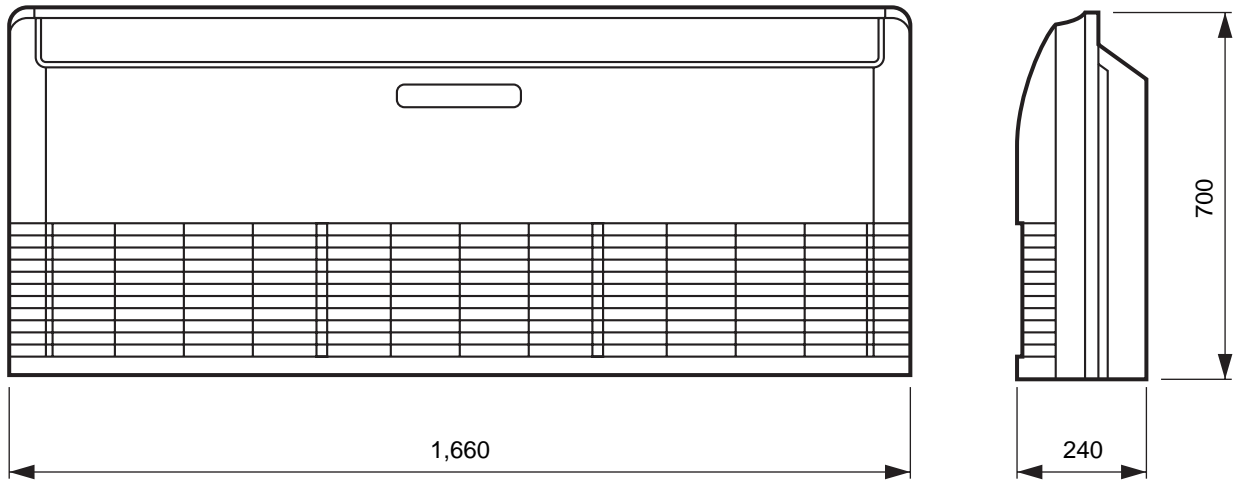

Models : RO-36EP
RO-45EP

(Unit : mm)

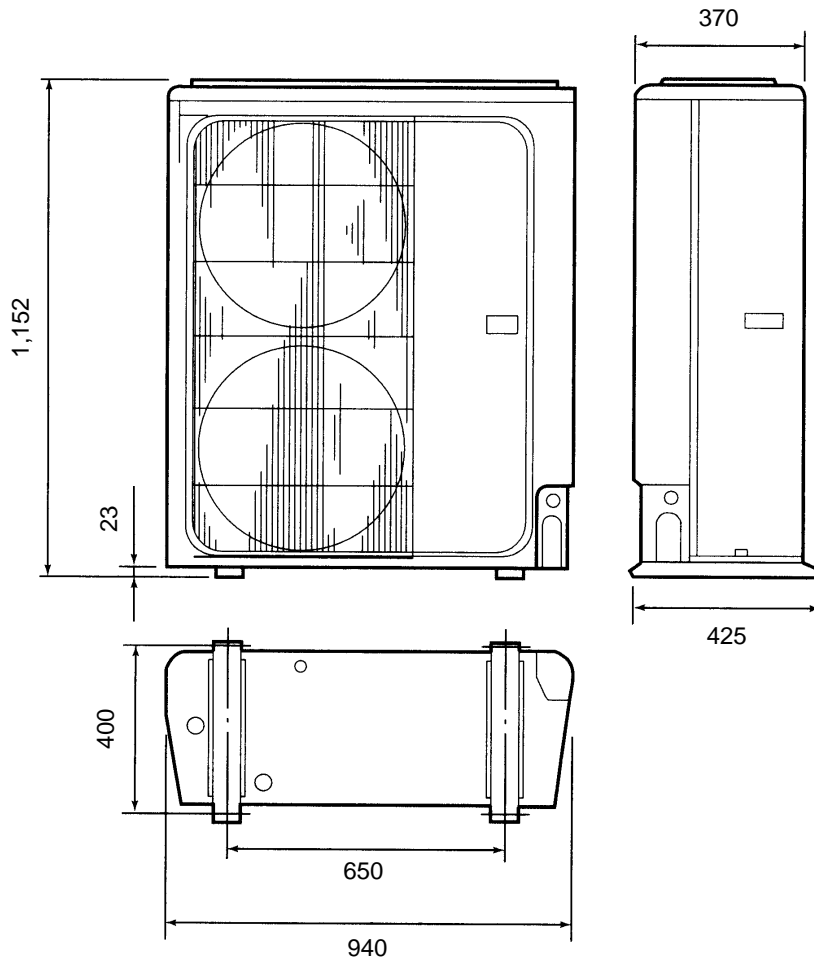

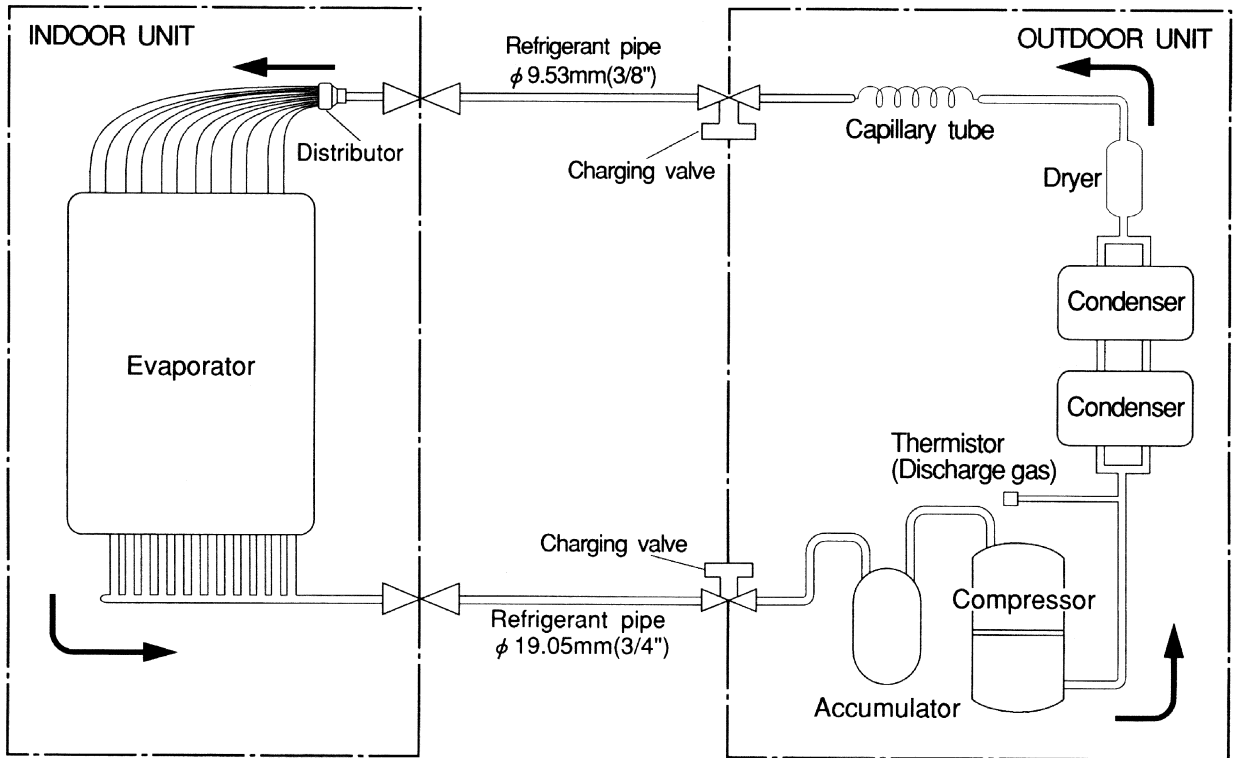

REFRIGERANT SYSTEM DIAGRAM

Models : RY-36EA / RO-36EP

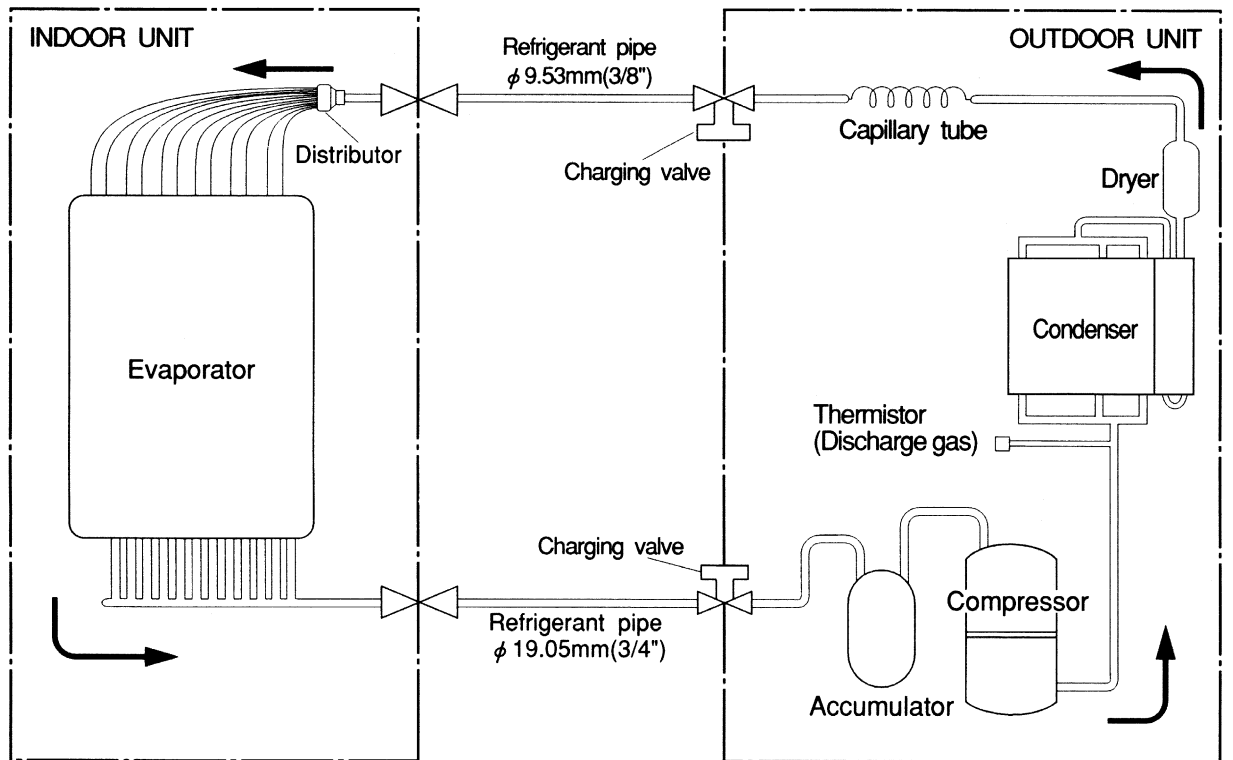

Models : RY-45EA / RO-45EP



 : Flare coupling
 : Cooling

CIRCUIT DIAGRAM

Models : RY-36EA / RO-36EP
RY-45EA / RO-45EP

INDOOR UNIT

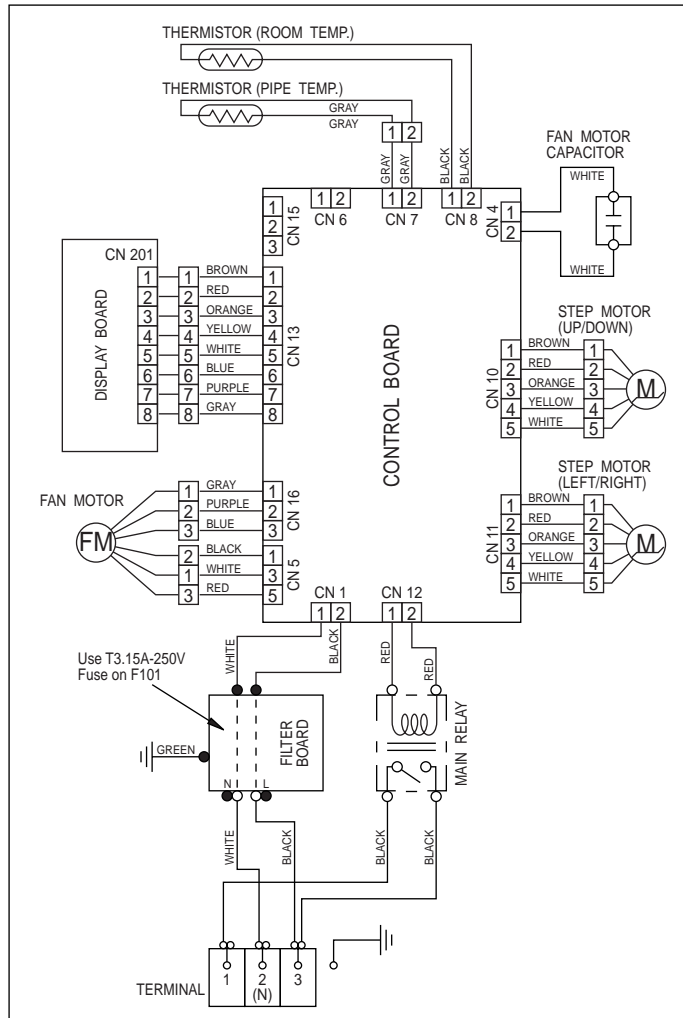

OUTDOOR UNIT

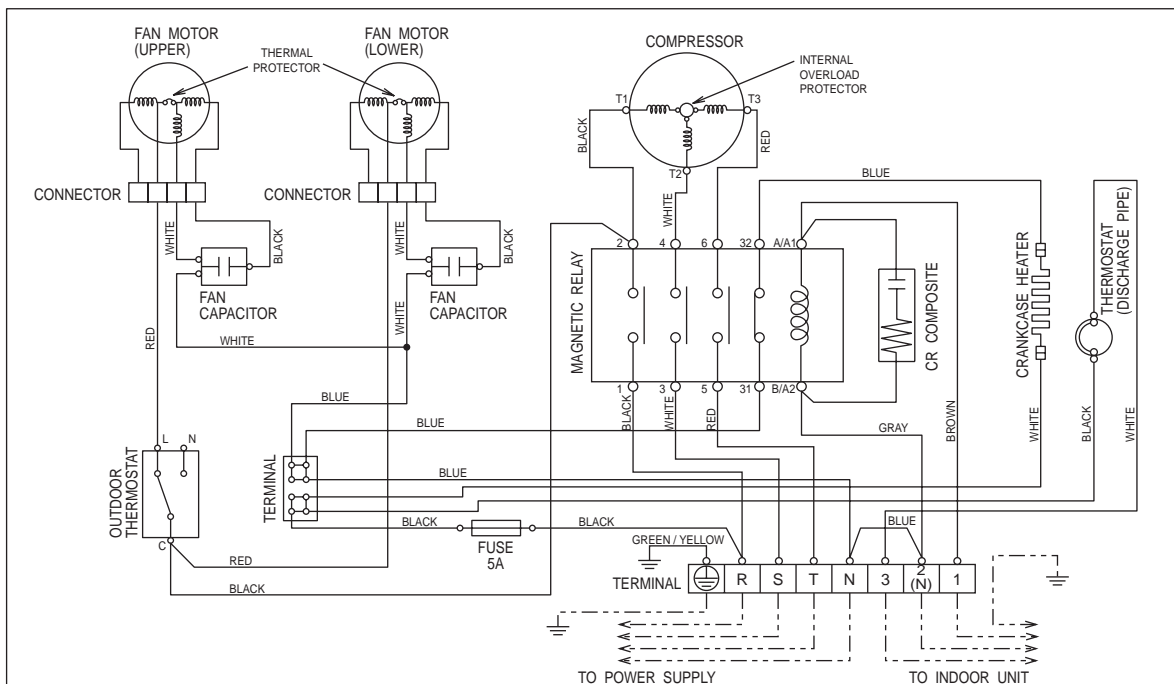

INDOOR PRINTED CIRCUIT BOARD CIRCUIT DIAGRAM

Models : RY-36EA
RY-45EA

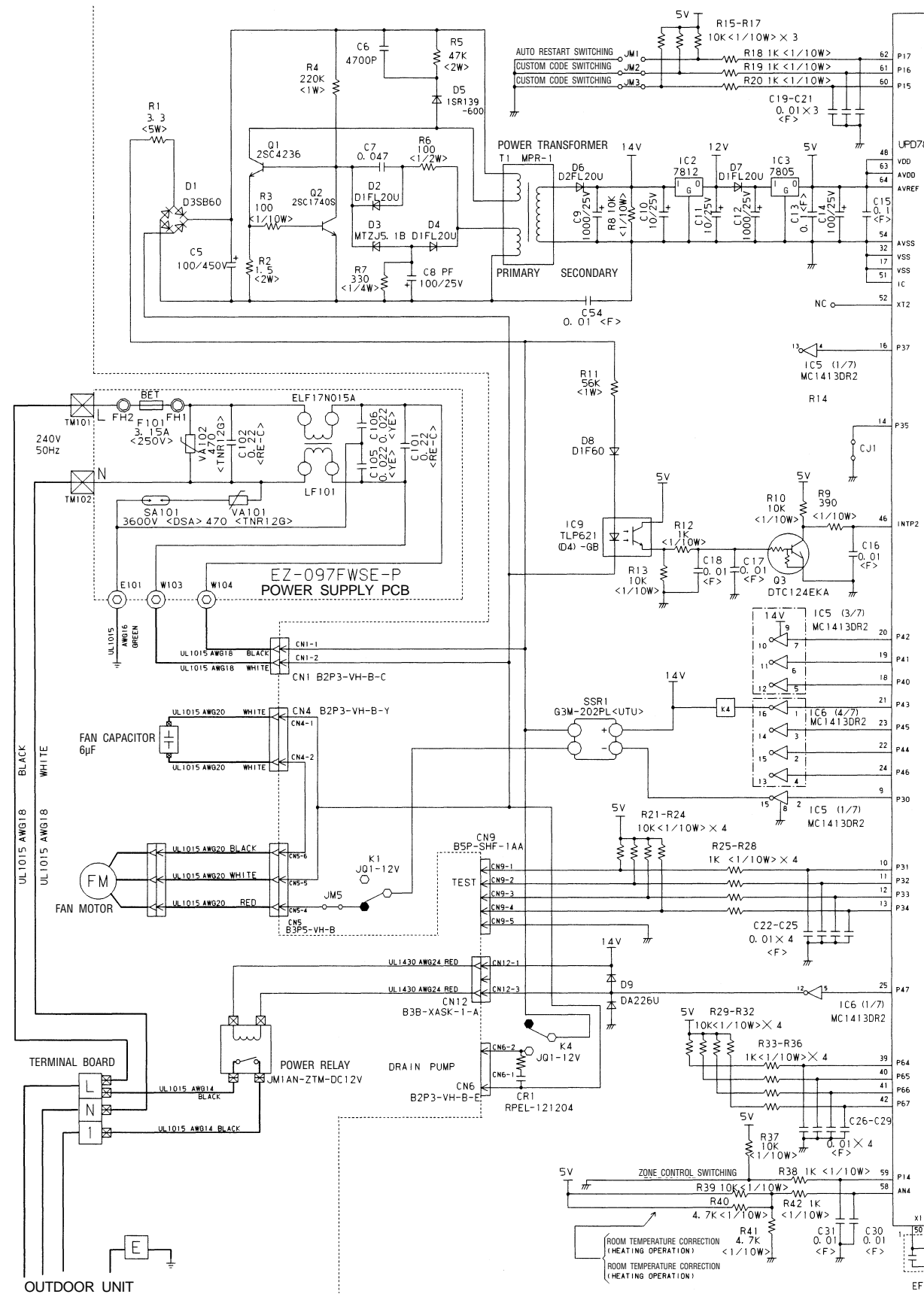

CONTROLLER PCB ASSEMBLY (MAIN PCB) EZ-097FWSE-C

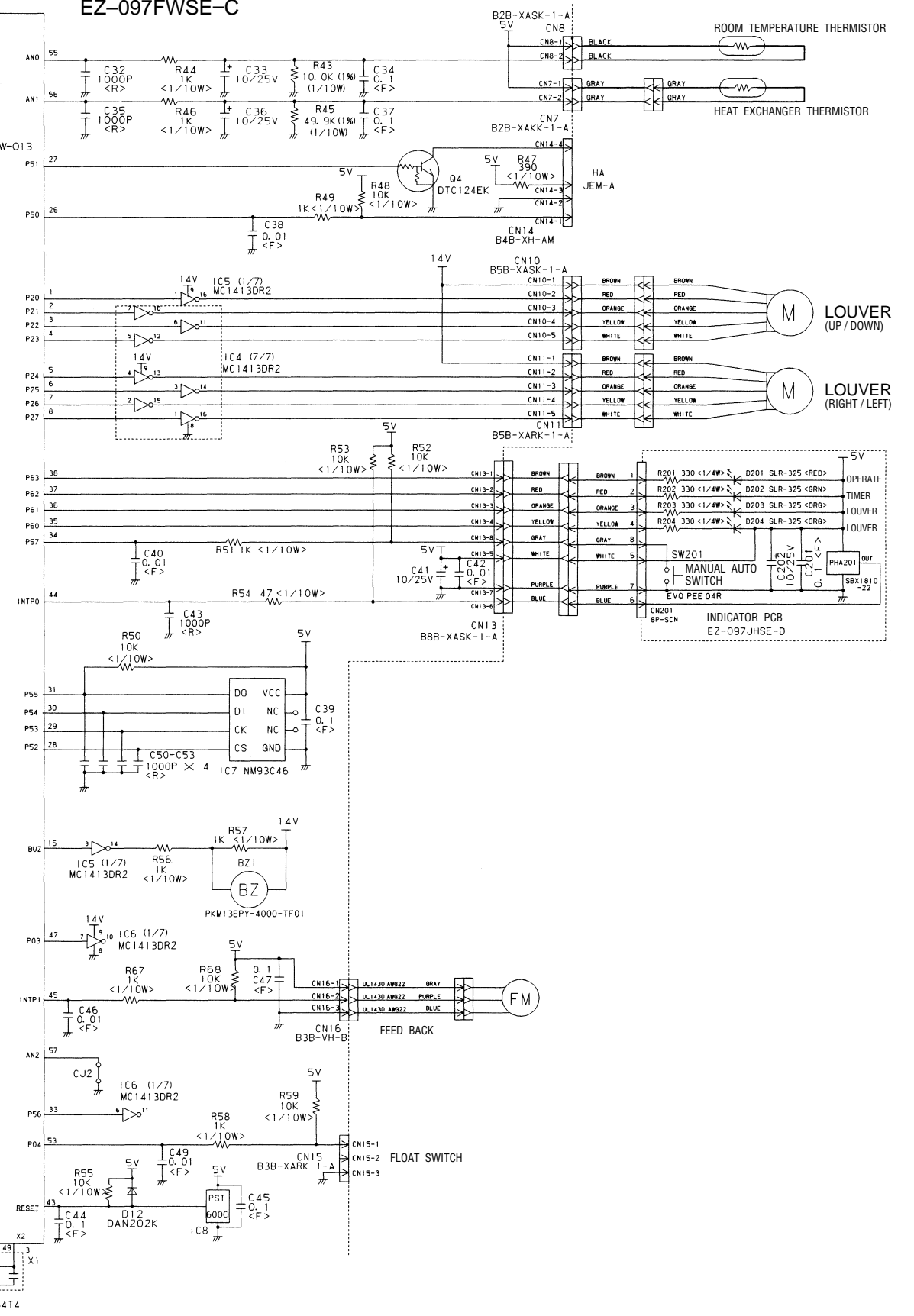

REMOTE CONTROL UNIT CODE SWITCHING

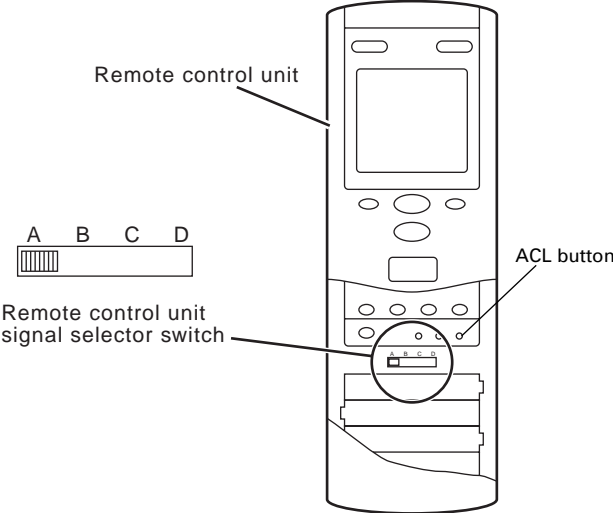
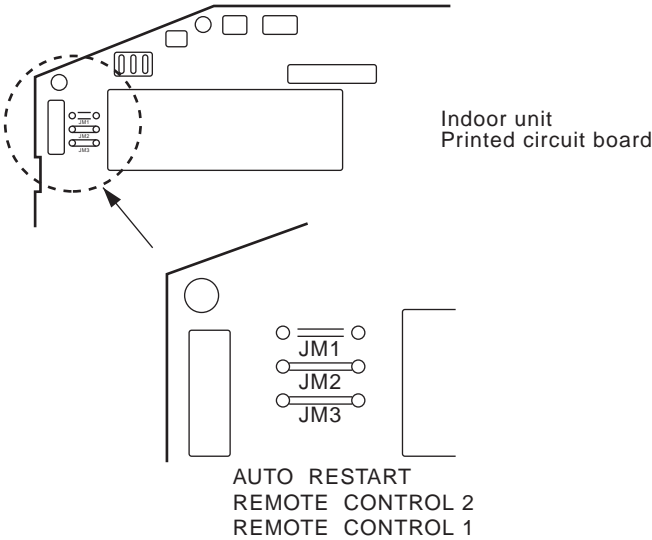

Confirm the remote control unit signal selector switch selection and printed circuit board setting. If these are not confirmed, the remote control unit cannot be operated for the air conditioner.

Jumper wire		Remote control unit signal selector switch
JM 2	JM 3	
Connect	Connect	A (Primary setting)
Connect	Disconnect	B
Disconnect	Connect	C
Disconnect	Disconnect	D

After setting the remote control unit signal selector switch, press the ACL button.

DISASSEMBLY ILLUSTRATION

Models : RY-36EA
RY-45EA

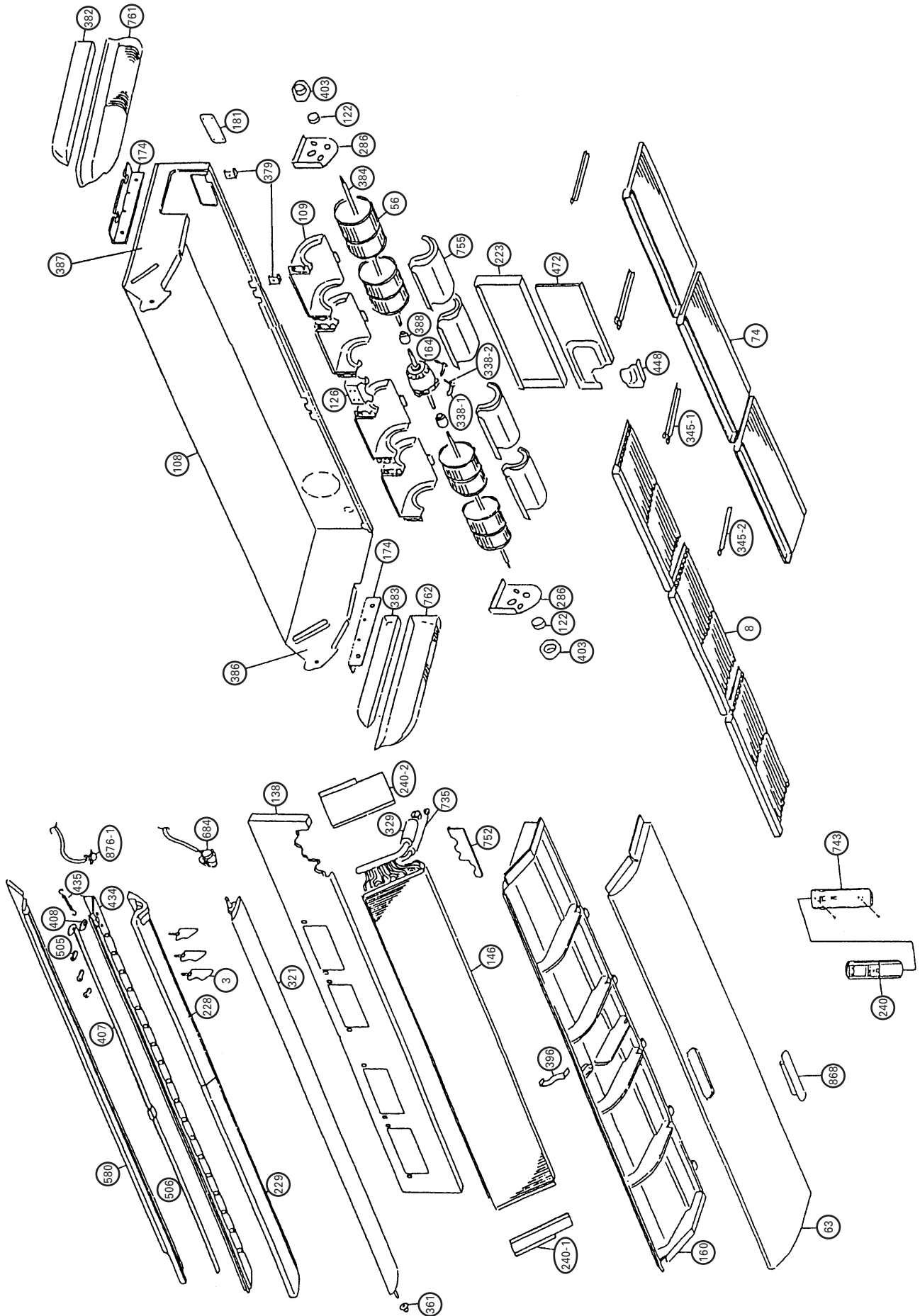

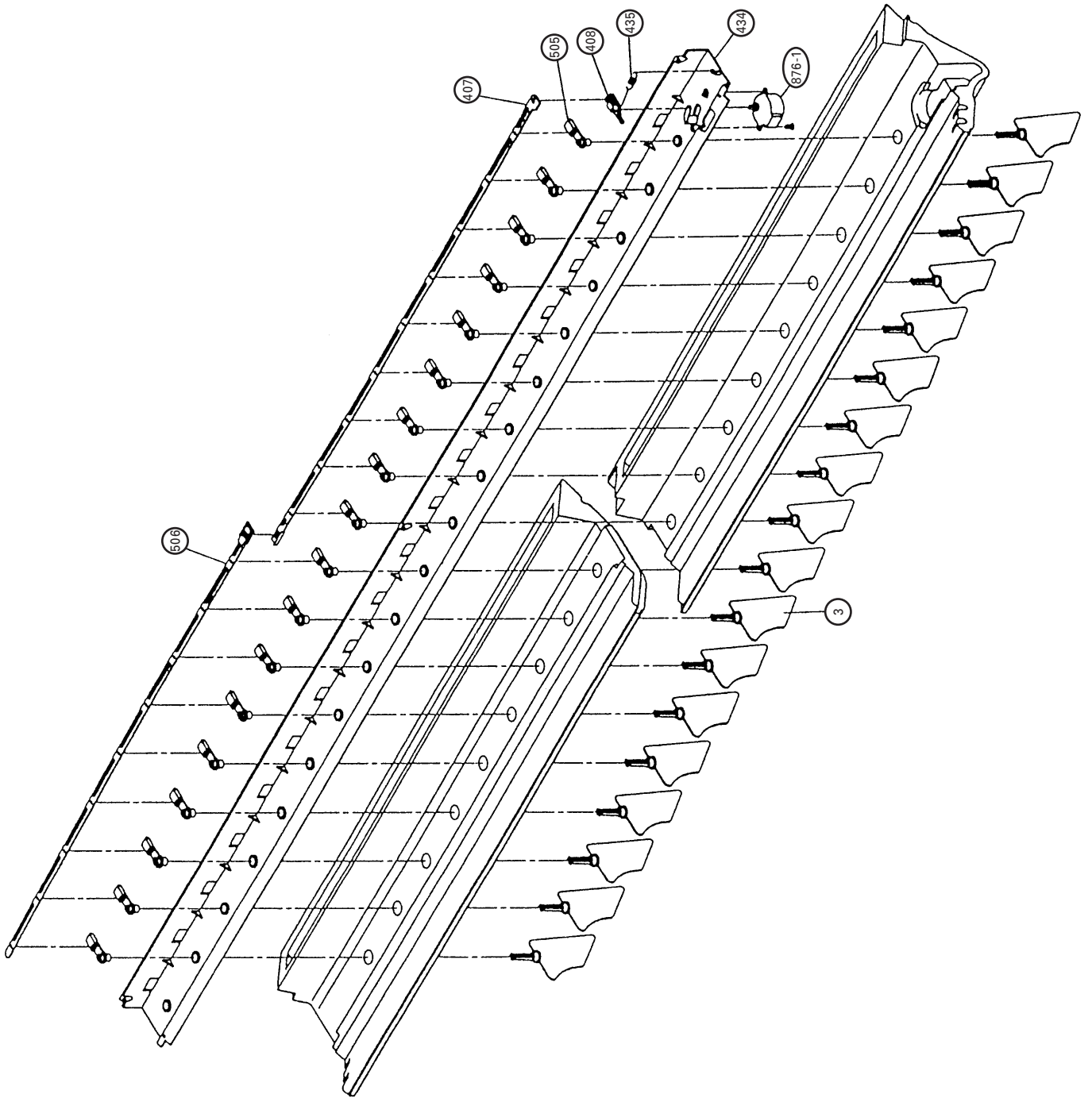

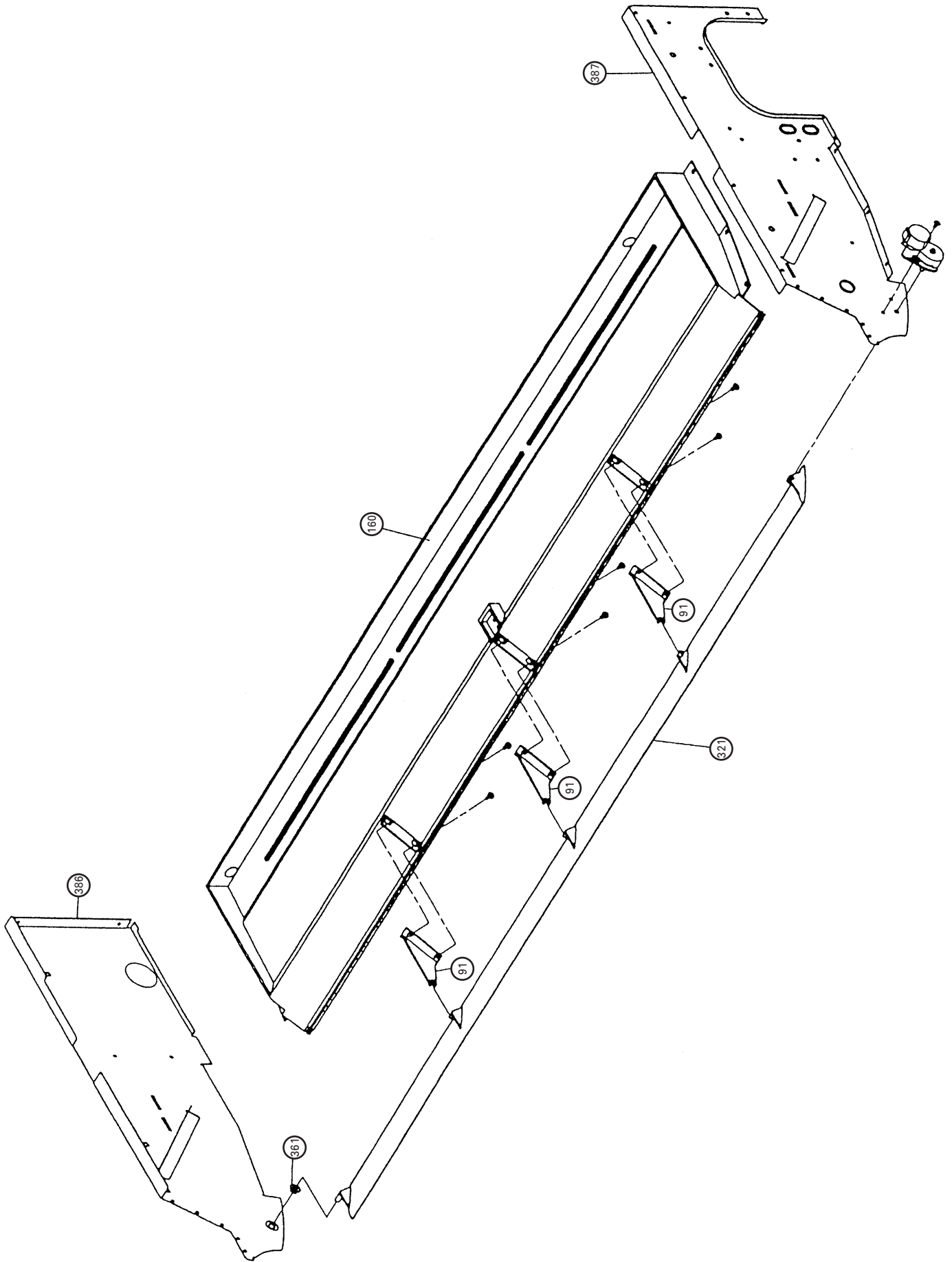

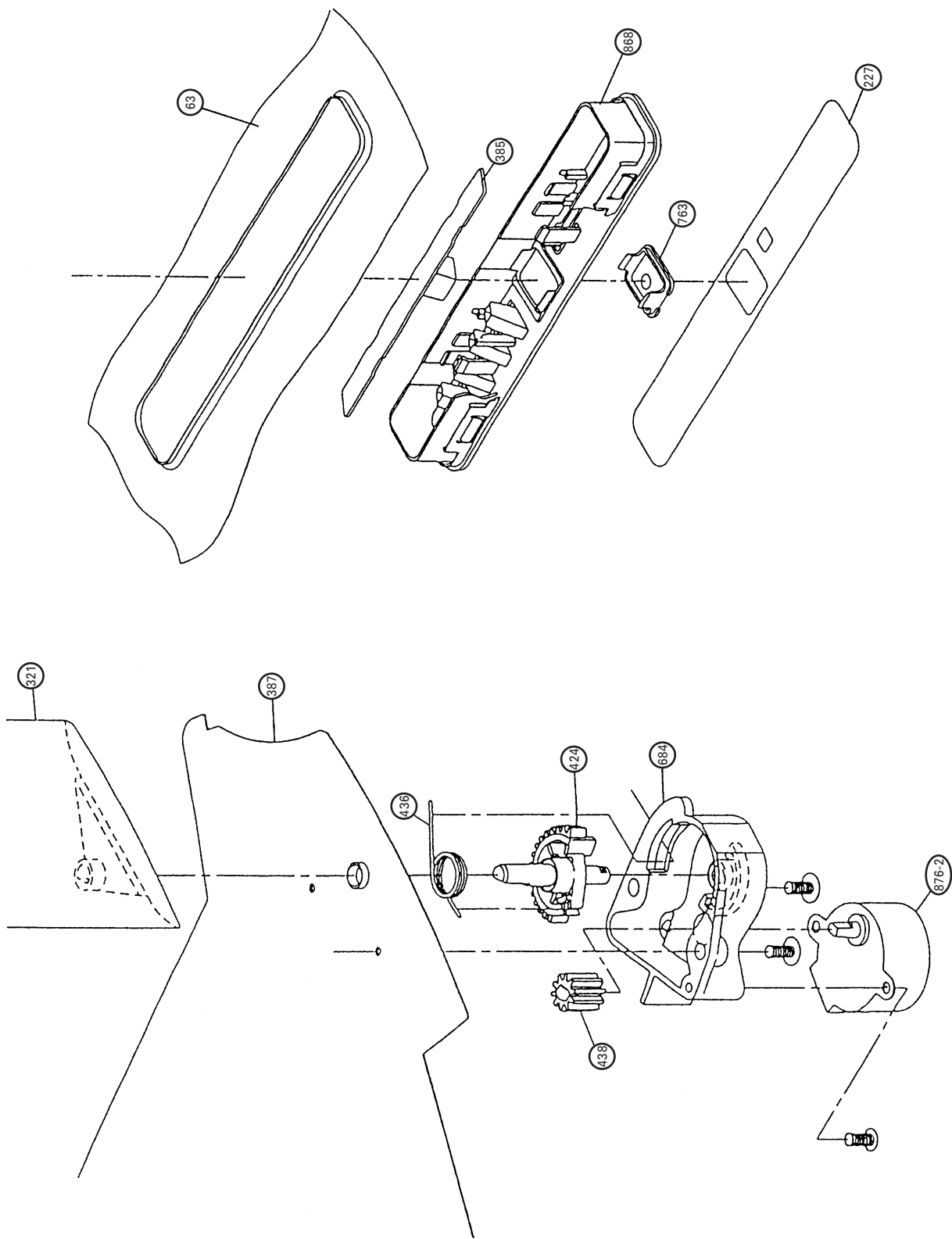

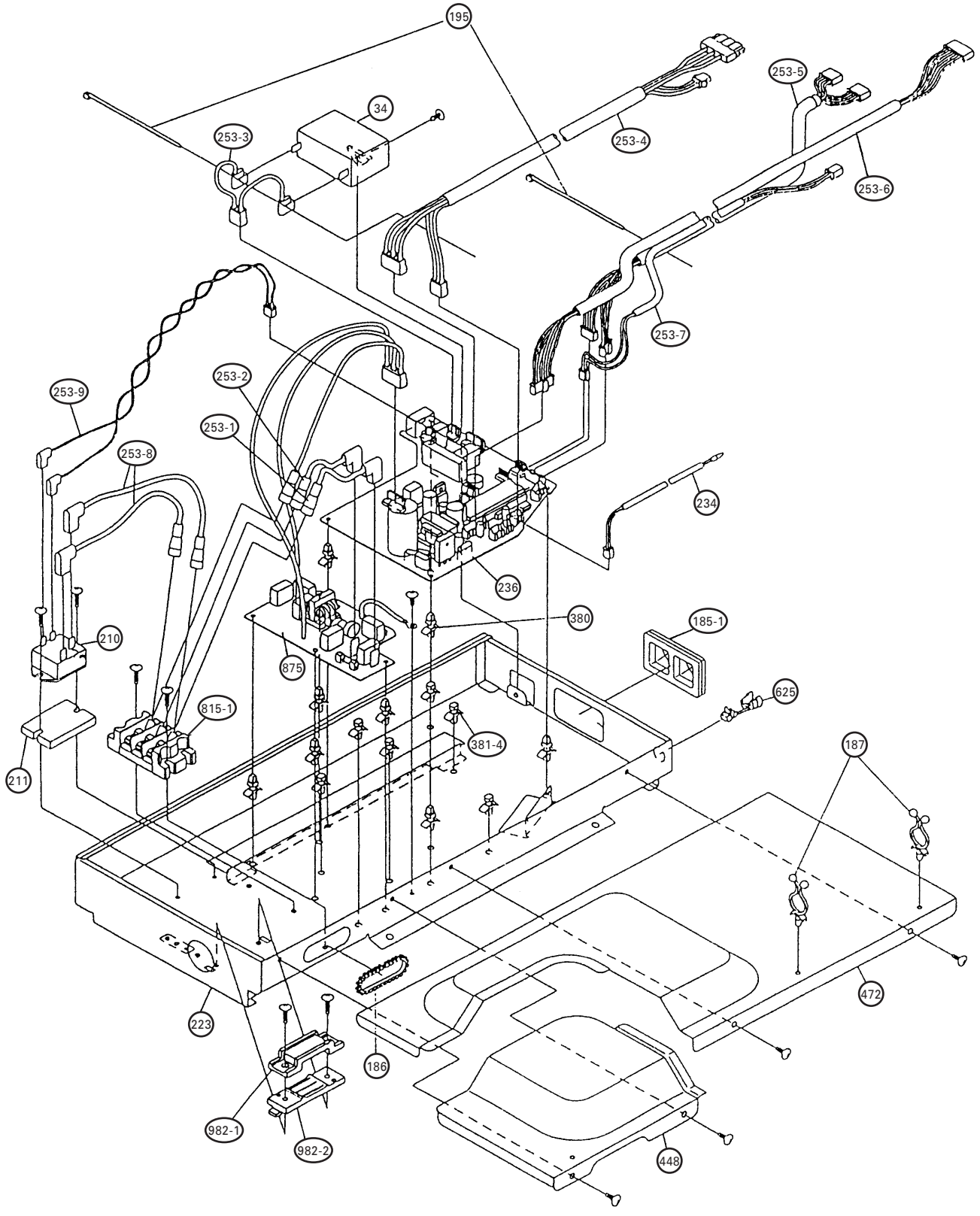

Models : RO-36EP
RO-45EP

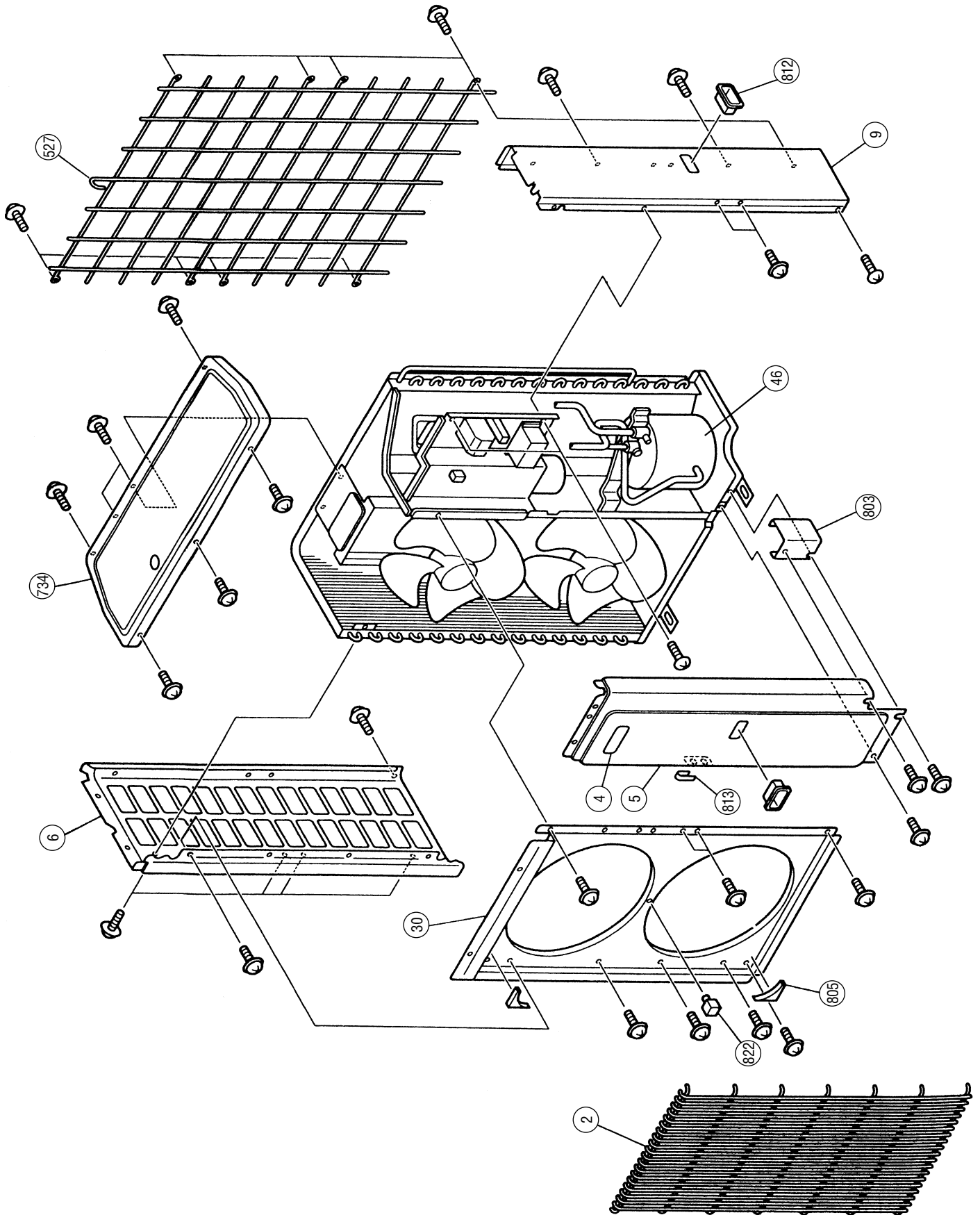

Model : RO-36EP

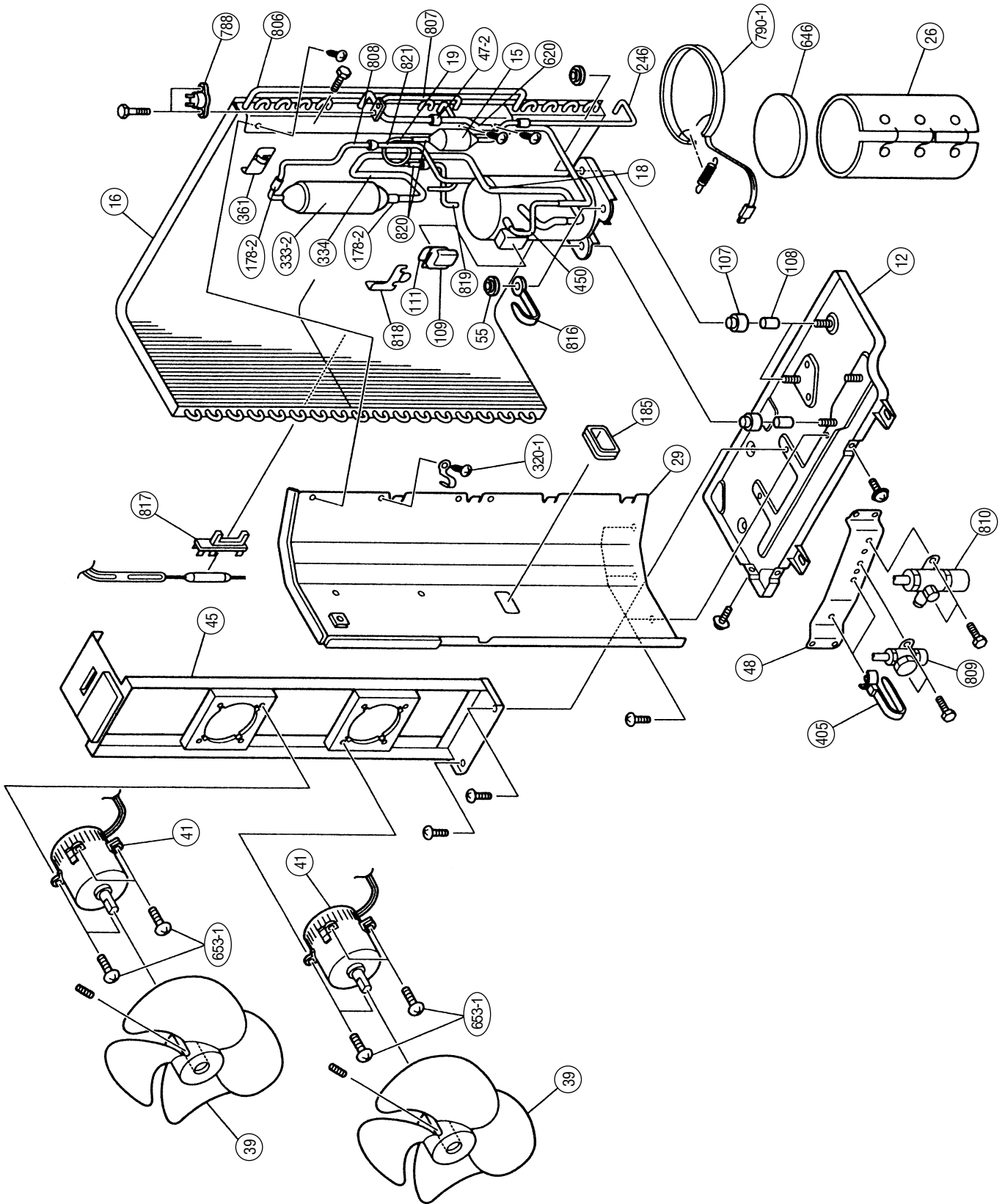

Model : RO-45EP

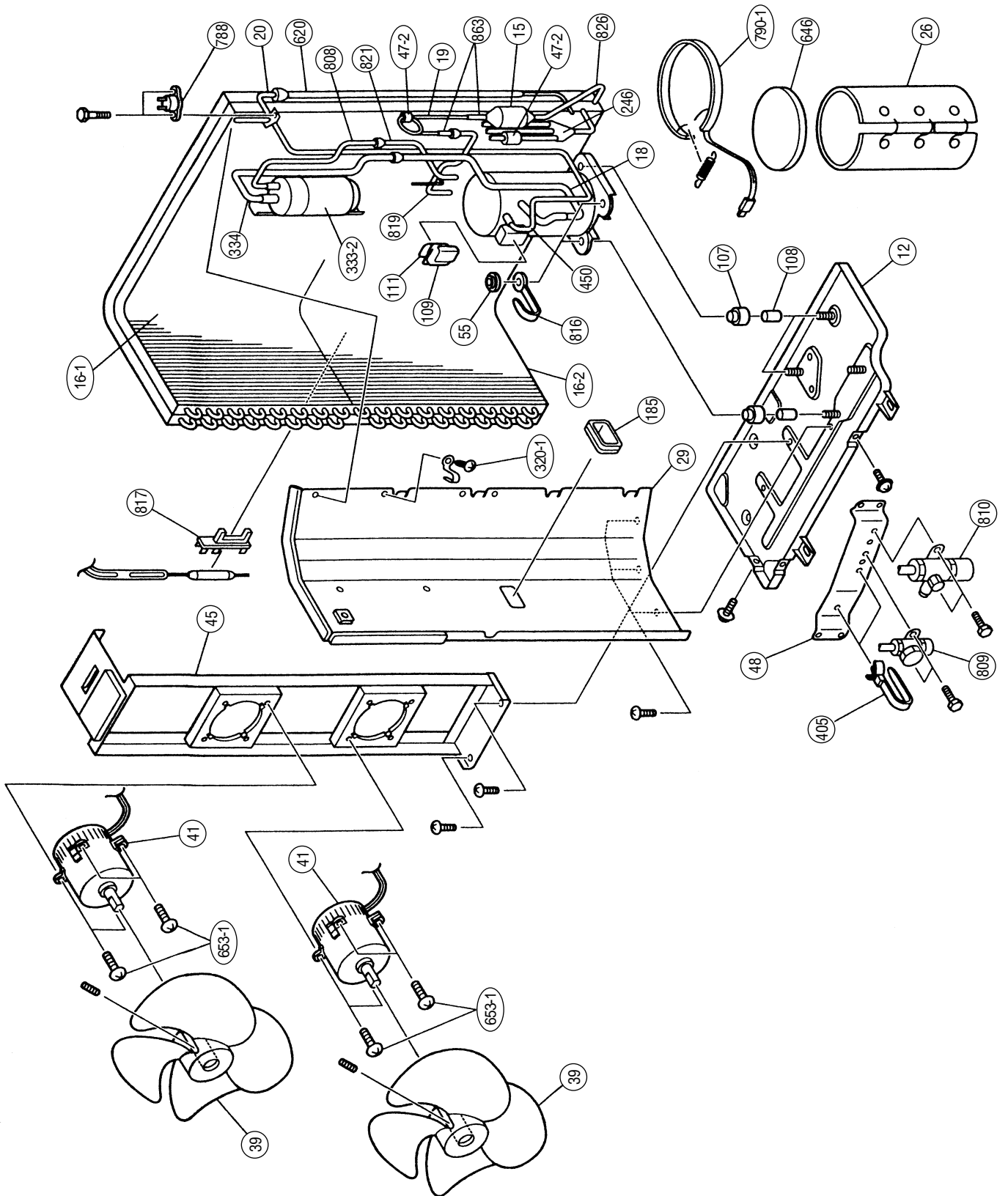

Models : RO-36EP
RO-45EP

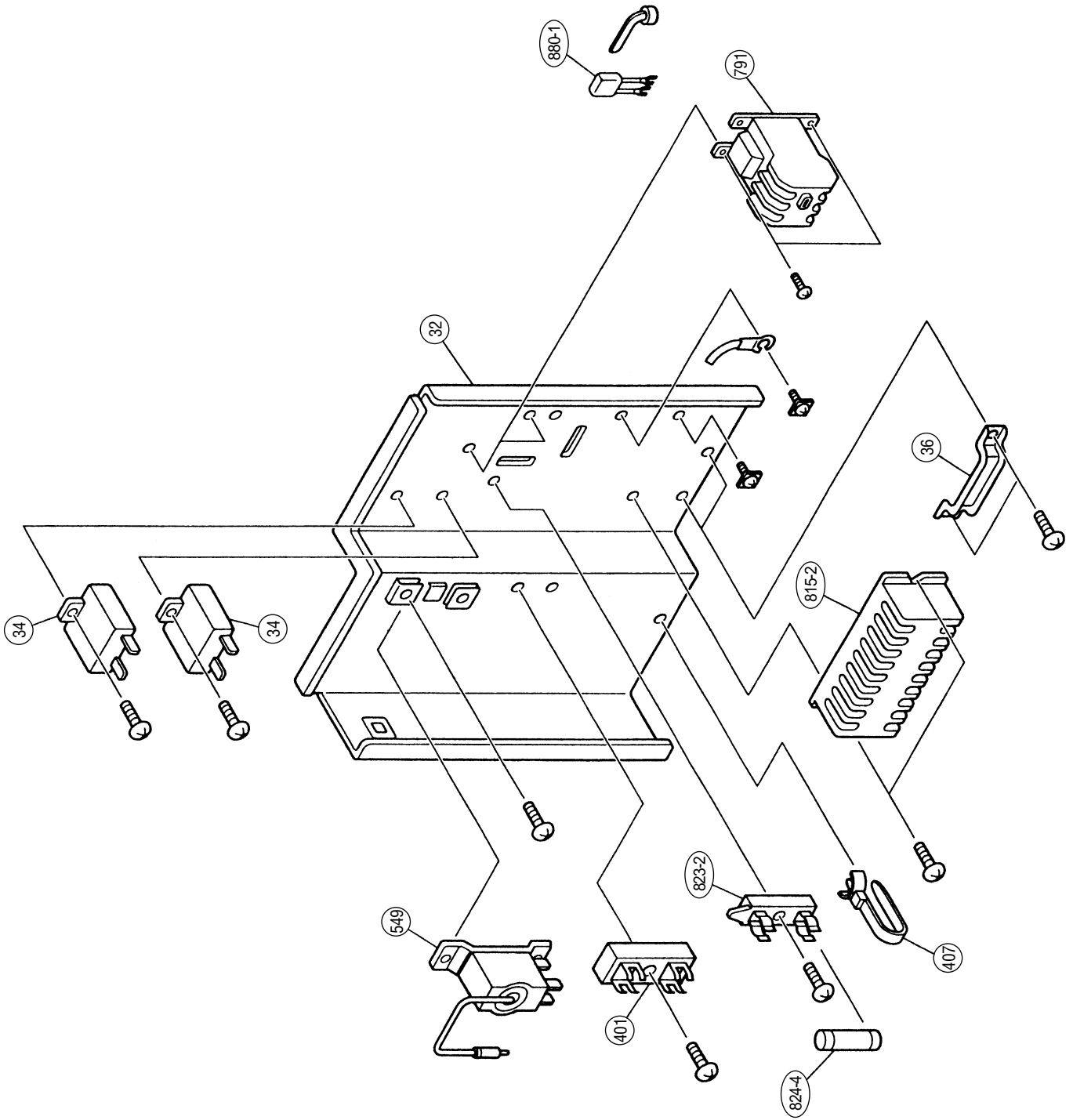

PARTS LIST

When you order parts, please make a photocopy of this page and fill the number of the parts in the "Order" column.

INDOOR UNIT

Ref. No.	Description	Part No.		Ord. Q'ty	Ref. No.	Description	Part No.		Ord. Q'ty
		RY-36EA	RY-45EA				RY-36EA	RY-45EA	
3	Louver	9359719007	9359719007		338-2	Fixture (Motor)-B	9359703006	9359703006	
8	Air Filter	9359739005	9359739005		345-1	Filter Guide-R	9359692003	9359692003	
34	Capacitor (Fan Motor)	9703306068	9703306068		345-2	Filter Guide-L	9359693000	9359693000	
56	Sirocco Fan Assy	9359701002	9359701002		361	Bushing	9359733003	9359733003	
63	Panel (Front)	9359734000	9359734000		379	Hinge Plate (Grille)	9359694007	9359694007	
74	Intake Grille	9359738008	9359738008		380	Locking Spacer KGLS-6S	313209391403	313209391403	
91	Hinge	9359699002	9359699002		381-4	Locking Spacer KGPS-6S	0600118075	0600118075	
108	Base Assy	9359680000	9359680000		382	Cover (Decoration)-R	9359744009	9359744009	
109	Casing	9359704003	9359704003		383	Cover (Decoration)-L	9359745006	9359745006	
122	Shaft Holder-B	9357921006	9357921006		384	Shaft	9359707004	9359707004	
126	Motor Fixing Table	9359681007	9359681007		385	Indicator PCB Assy	9702260019	9702260019	
138	Separate Wall	9359700005	9359700005		386	Panel-Left Assy	9359685005	9359685005	
146	Evaporator Assy	9364045009	9364045009		387	Panel-Right Assy	9359683001	9359683001	
160	Drain Pan	9359698005	9359698005		388	Joint Assy	9359706007	9359706007	
164	Fan Motor Assy-IN	9360457004	9360457004		396	Reinforcement Metal	9359697008	9359697008	
174	Hanger Bracket	9359742005	9359742005		403	Shaft Holder Fixture	9359687009	9359687009	
181	Hole Cover	9359691006	9359691006		407	Rod (Motor)	9359723004	9359723004	
185-1	Rubber Bushing	9357376004	9357376004		408	Louver Link	9359726005	9359726005	
186	Edge Cover	9361049017	9361049017		424	Sector Gear	9359729006	9359729006	
187	Clamp No.1219	313361271706	313361271706		434	Louver Base	9359718000	9359718000	
195	Clamp SKB-100	313361275805	313361275805		435	Louver Spring	9359720003	9359720003	
210	Main Relay	9356781007	9356781007		436	Flap Spring	9359730002	9359730002	
211	Cushion Rubber	313806328306	313806328306		438	Pinion Gear	9359728009	9359728009	
223	Control Box Assy	9359708001	9359708001		448	Control Box-B	9359713005	9359713005	
227	Badge "FUJI"	9359735045	9359735045		472	Control Box-A	9359712008	9359712008	
228	Insulation (Louver)-R	9359721000	9359721000		505	Louver Stopper	9359724001	9359724001	
229	Insulation (Louver)-L	9359722007	9359722007		506	Louver Rod	9359725008	9359725008	
234	Thermistor Assy-Room	9703299025	9703299025		580	Cover (Top)	9359737001	9359737001	
236	Controller PCB Assy	9701941186	9701941186		625	Cord Bushing	9359240006	9359240006	
240	Remote Control Unit	9359913061	9359913061		684	Motor Base	9359727002	9359727002	
240-1	Cover Panel (Pipe)-L	9359690009	9359690009		735	Distributor Assy	9364046006	9364046006	
240-2	Cover Panel (Pipe)-R	9359689003	9359689003		743	Remote Control Holder Case	9359955016	9359955016	
253-1	Wire Assy (Connector)	9702321017	9702321017		752	Pipe Fixture Metal	9359688006	9359688006	
253-2	Wire Assy (Connector)	9702322014	9702322014		755	Cover (Casing)	9359705000	9359705000	
253-3	Wire Assembly	9702311018	9702311018		761	Cover (Side)-R	9359740001	9359740001	
253-4	Wire Assy (Connector)	9702323011	9702323011		762	Cover (Side)-L	9359741008	9359741008	
253-5	Wire Assy (Connector)	9702319014	9702319014		763	Cover (Receiver)	9359714002	9359714002	
253-6	Wire Assy (Connector)	9702317010	9702317010		815-1	Terminal-3P	9358660027	9358660027	
253-7	Wire Assy (Connector)	9702318017	9702318017		868	PCB Holder	9359736004	9359736004	
253-8	Wire Assy (Connector)	9702066055	9702066055		875	Filter PCB Assy	9702275013	9702275013	
253-9	Wire Assembly	9702309015	9702309015		876-1	Motor, Step-H	9360479013	9360479013	
286	Shaft Holder Bracket	9359686002	9359686002		876-2	Motor, Step-V	9360307026	9360307026	
321	Flap Assy	9359731009	9359731009		982-1	Cord Clamp-A	9359820017	9359820017	
329	Coupling Pipe Assy	9364047003	9364047003		982-2	Cord Clamp-B	9359821014	9359821014	
338-1	Fixture (Motor)	9359702009	9359702009						

When you order parts, please make a photocopy of this page and fill the number of the parts in the "Order" column.

OUTDOOR UNIT

Ref. No.	Description	Part No.		Ord. Q'ty	Ref. No.	Description	Part No.		Ord. Q'ty
		RO-36EP	RO-45EP				RO-36EP	RO-45EP	
2	Fan Cover	9352159015	9352159015		361	Accumulator Support Assy	9355351003	———	
4	Emblem-Rear	9361328006	9361328006		401	Terminal-2P	9701971015	9701971015	
5	Cabinet-A, Painted	9352146015	9352146015		405	Clamp No.1763	313816345304	313816345304	
6	Cabinet-C, Painted	9352149016	9352149016		407	Clip (Cable) No.1259	313739340109	313739340109	
9	Cabinet-B, Painted	9352147012	9352147012		450	Discharge Pipe-A	9364079004	9364079004	
12	Base Assy, Painted	9352136016	9352136016		527	Protection Net	9352163012	9352163012	
15	Dryer	9362498005	9362498005		549	Thermistor Outdoor	9352426001	9352426001	
16	Condenser Assy	9364074009	———		620	Inlet Pipe (Cond.) Assy	9364068008	9364090009	
16-1	Condenser-A Assy	———	9364064000		646	Compressor Cover-B	9364089003	9364089003	
16-2	Condenser-B Assy	———	9364061009		653-1	Bolt (Fan Motor Fixing)	0700156014	0700156014	
18	Suction Pipe Assy	9364514000	9364514000		734	Cabinet Top Plate	9352161018	9352161018	
19	Capillary Tube	9364083001	9364053004		788	Thermistor-Overheat	9354061002	9354061002	
20	Discharge Pipe Assy	———	9364132006		790-1	Belt Heater-A	9361140042	9361140042	
26	Compressor Cover-A	9364088006	9364088006		791	Magnetic Relay	9363277005	9363277005	
29	Separate Wall	9355277013	9355277013		803	Cabinet-D, Painted	9352150012	9352150012	
30	Blower Cover, Painted	9352151019	9352151019		805	Blower Cover Corner	9352160011	9352160011	
32	Control Box Metal	9352134012	9352134012		806	Cond. Pass Pipe-A	9364075006	———	
34	Capacitor (Fan Motor)	9357965024	9357965024		807	Cond. Pass Pipe-B	9364076003	———	
36	Cord Holder Metal	9356934007	9356934007		808	Inlet Pipe (Accumulator)	9364066004	9362558006	
39	Propeller Fan Assy	9300855013	9300855013		809	Ball Valve-A	9362578004	9362578004	
41	Fan Motor Assy-Out	9600832028	9600832028		810	Ball Valve-B	9362579001	9362579001	
45	Bracket (Motor) Assy	9352141003	9352141003		812	Grip	9352157004	9352157004	
46	Compressor Assy	9367375004	9367376001		813	Cabinet Hook	9352148002	9352148002	
47-2	Rubber (Discharge Pipe)	313185159802	313185159802		815-2	Terminal-8P	9363276022	9363276022	
48	Bracket (Coupler) Assy	9355281010	9355281010		816	Wire Clamp Metal	313584219902	313584219902	
55	Special Nut M8 (For Comp.)	313252257701	313252257701		817	Thermostat Fixture	9352164019	9352164019	
107	Rubber Seat-A (For Comp.)	9364084008	9364084008		818	Accumulator Support-B Assy	9355350006	———	
108	Sleeve-A (For Comp.)	9364085005	9364085005		819	Valve-A Coupl. Pipe	9364081007	9364052007	
109	Terminal Cover (For Comp.)	9364087009	9364087009		820	Joint Pipe (Capillary)	9364082004	———	
111	Terminal Packing	9364086002	9364086002		821	Joint Pipe Assy	9364080000	9362564007	
178-2	Capillary Holder Rubber	313394274808	———		822	Fan Cover Fixture-A	9352158018	9352158018	
185	Rubber Bushing	313005066051	313005066051		823-2	Fuse Holder	0500063024	0500063024	
246	Outlet Pipe (Cond.) Assy	9364178004	9364060002		824-4	Fuse	0600222529	0600222529	
320-1	Wire Clamp Metal	313483219905	313483219905		826	Condensing Pipe-B	———	9364062006	
333-2	Accumulator (B)	9301942019	9357987002		863	Joint Pipe (Capillary)-B	———	9362563000	
334	Suction Pipe-B	9364065007	9362557009		880-1	Network	9700987017	9700987017	

When you order parts, please make a photocopy of this page and fill the number of the parts in the "Order" column.

[INDOOR P.C.B.]

CONTROLLER PCB ASSEMBLY (Ref. No. 236)

Ref. No.	Description	Part No.	Ord. Qty	Ref. No.	Description	Part No.	Ord. Qty
IC1	IC μ PD78014HCW-013	9702426026		R54	Res. 1/10W 47 Ω \pm 5%	0200212425	
IC2	IC μ PC7812AHF	0100008104		CJ1,2	Res. 0 Ω	0200212012	
IC3	IC μ PC7805AHF	0100008036		C5	Cap. Elec. 450V 100 μ F	0300256060	
IC4~6	Xstr μ PA2003GR	0100028041		C6	Cap. Plastic 4700pF	0300269091	
IC7	IC NM93C46M8-X	0101622026		C7	Cap. Plastic 50V 0.047 μ F	0300169339	
IC8	IC PST600CMTR	0101461120		C8	Cap. Elec. 25V 100 μ F	0301197560	
IC9	Photocoupler TLP621(D4)-GB	0000117074		C9	Cap. Elec. 25V 1000 μ F	0301196495	
Q1	Xstr 2SC4236	0000164047		C10,11,33,36,41	Cap. Elec. 25V 10 μ F	0301192312	
Q2	Xstr 2SC1740S	0000699235		C12	Cap. Elec. 25V 1000 μ F	0301158264	
Q3,4	Xstr DTC124EKA	0000936033		C13,15,34,37,39,44,45	Cap. Ceramic 50V 0.1 μ F	0300311752	
D1	Diode D3SB60	0000689045		C14	Cap. Elec. 25V 100 μ F	0301192350	
D2,4,7	Diode D1FL20U	0000746519		C16~31,38,40,42,46,49	Cap. Ceramic 50V 0.01 μ F	0300311738	
D3	Diode MTZJ5.1B	0000852166		C32,35,43,50~53	Cap. Ceramic 50V 1000pF	0300308509	
D5	Diode 1SR139-600	0000353120		C54	Cap. Ceramic 0.01 μ F	0300727539	
D6	Diode D2FL20U	0000906500		K1,4	Relay JQ1-12V	9701316014	
D8	Diode D1F60	0000208024		SSR1	Relay G3M-202PL-UTU	9701653010	
D9	Diode DA226U	0000625036		T1	Switching Transformer ETS28AS118AH	9702727017	
D12	Diode DAN202K	0000684019		X1	Ceramic Resonator EF0EC8384T4	9701261017	
R1	Res. Wire Wound 5W 3.3 Ω \pm 10%	0200244372		BZ1	Buzzer PKM13EPY-4000-TF01	9701298013	
R2	Res. Metal Oxide 2W 1.5 Ω \pm 5%	0201107119		CR1	Network RPEL-121204	9701125012	
R3	Res. 1/10W 100 Ω \pm 5%	0200212500		CN1	Plug, PCB B2P3-VH-B-C	0500011773	
R4	Res. Carbon 1W 220k Ω \pm 5%	0200111353		CN4	Plug, PCB B2P3-VH-B-Y	0500011827	
R5	Res. Metal Oxide 2W 47k Ω \pm 5%	0201107652		CN5	Plug, PCB B3P5-VH-B	0500011735	
R6	Res. 1/2W 100 Ω \pm 5%	0200731506		CN6	Plug, PCB B2P3-VH-B-E	0500011759	
R7	Res. 1/4W 330 Ω \pm 5%	0200708621		CN7	Plug, PCB B2B-XAKK-1-A	0501045227	
R8,10,13,15~17,21~24,29~32,37,39,48,50,52,53,55,59,68	Res. 1/10W 10k Ω \pm 5%	0200213019		CN8	Plug, PCB B2B-XASK-1-A	0501045012	
R9,47	Res. 1/10W 390 Ω \pm 5%	0200212647		CN9	Plug, PCB B2P-SHF-1AA	0500006069	
R11	Res. Metal Oxide 1W 56k Ω \pm 5%	0201106662		CN10	Plug, PCB B5B-XASK-1-A	0501045043	
R12,18~20,25~28,33~36,38,42,44,46,49,51,56~58,67	Res. 1/10W 1k Ω \pm 5%	0200212746		CN11	Plug, PCB B5B-XARK-1-A	0501045517	
R40,41	Res. 1/10W 4.7k Ω \pm 5%	0200212906		CN12	Plug, PCB B3B-XASK-1-A	0501045029	
R43	Res. 1/10W 10k Ω \pm 5%	0200279497		CN13	Plug, PCB B8B-XASK-1-A	0501045074	
R45	Res. 1/10W 49.9k Ω \pm 1%	0200279824		CN14	Plug, PCB B4B-XH-AM	0500005314	
				CN15	Plug, PCB B3B-XARK-1-A	0501045319	
				CN16	Plug, PCB B3B-VH-B	0500011520	

[INDOOR UNIT]











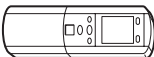

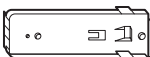
FILTER PCB ASSEMBLY (Ref. No. 875)

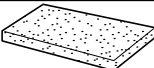
Ref. No.	Description	Part No.	Ord. Qty	Ref. No.	Description	Part No.	Ord. Qty
C101,102	Cap. Plastic 0.22 μ F	0300304099		LF101	EMI Filter ELF17N015A	0400197119	
C105,106	Cap. Plastic 0.022 μ F	0301052098		F101	Fuse BET 3.15A-250V	0600222512	
SA101	Arrester DSA-362MA-05	0600168032		FH1,2	Fuse Holder PFC5000-0502	0500158072	
VA101,102	Varistor TNR12G471K	0000038010		E101	Wire w/Terminal GRN L=100	9702313012	
TM101,102	Plug Contact 86028	0500536016		W103,104	Wire #18 2P	9702419011	

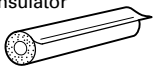
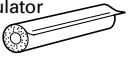



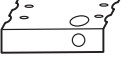

INDICATOR PCB ASSEMBLY (Ref. No. 385)

Ref. No.	Description	Part No.	Ord. Qty	Ref. No.	Description	Part No.	Ord. Qty
D201	Diode SLR-325VC RED	0000813259		R201~204	Res. Carbon 1/4W 330 Ω \pm 5%	0201038659	
D202	Diode SLR-325MC GRN	0000813242		PHA201	Remote Control Amplifier SBX1810-22	0101525129	
D203,204	Diode SLR-325DC ORG	0000813235		SW201	Switch, Push EVQ-PAG-04K	9700450016	
C201	Cap. Ceramic 0.1 μ F	0300988251		CN201	Wire w/Connector L=300	9702264017	
C202	Cap. Elec. 25V 10 μ F	0300004258					

INDOOR UNIT ACCESSORIES

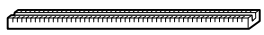
Name and Shape	Q'ty	Application	Parts No.
Remote control unit 	1	Use for air conditioner operation	9359913061 (AR-DL6)
Battery (pen light) 	4	For remote control unit	0600185534
Remote control unit holder 	1	For mounting the remote control unit	9359955016
Tapping screw (ø3 x 12) 	3	For remote control unit holder installation	301141533125
Drain hose insulation 	1	Adhesive type 70 x 230	9360464002
VT wire 	1	For fixing the drain hose L 280 mm	313806350303
Coupler heat insulator (large) 	2	For indoor side pipe joint (large pipe)	9350716029
Coupler heat insulator (small) 	1	For indoor side pipe joint (small pipe)	9352766015
Nylon fastener 	Large 4	For fixing the coupler heat insulator	9301501001
	Small 4		312300787605
Special nut A (large flange) 	4	For installing indoor unit	313005446653
Special nut B (small flange) 	4	For installing indoor unit	313005446759
Installation template 	1	For positioning the indoor unit	9360022004
Auxiliary pipe assembly 	1	For connecting the piping	9360463005

OUTDOOR UNIT ACCESSORIES

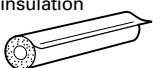
Name and Shape	Q'ty	Application	Parts No.
Power cap 	1	For power cord installation	9352173011
Auxiliary pipe assembly 	1	For wiring conduit (gas side) connection (May not be supplied, depending on the model)	9355292016
Edge cover 	1	For wiring conduit installation hole edge protection	9352436000
Tapping screw 	2	• For cabinet A and cabinet D mounting (1) • Spare (1)	301463040100
Binder 	1	For power cord binding	313035356905
Putty 	1	For sealing	303020200114
Coupler heat insulation 	1	For outdoor side pipe joint	313005074759



MANUFACTURER :

Fuji Denki Sosetsu Co., Ltd.

Tokyo, Japan