

DATE	BY	CHKD	APP'D	REV	DESCRIPTION
04-Jun-08	TKK	TKK	TKK		
13-Feb-09	TKK	TKK	TKK		
13-Feb-09	TKK	TKK	TKK		

THERMO KING PROPRIETARY DATA
 THIS INFORMATION IS TRANSMITTED TO YOU FOR YOUR INFORMATION ONLY. IT IS NOT TO BE REPRODUCED OR TRANSMITTED IN ANY FORM OR BY ANY MEANS, ELECTRONIC OR MECHANICAL, INCLUDING PHOTOCOPYING, RECORDING, OR BY ANY INFORMATION STORAGE AND RETRIEVAL SYSTEM, WITHOUT THE WRITTEN PERMISSION OF THERMO KING CORPORATION.

NO.	DATE	BY	CHKD	APP'D	DESCRIPTION
530309	TKK	TKK	TKK		RELEASED
533087	TKK	TKK	TKK		RELEASED
544105	TKK	TKK	TKK		UPDATE HMI VIEW UPDATE THM COLORS
549546	TKK	TKK	TKK		CORRECTED ZONE REF LABELS UPDATE FOR SR3

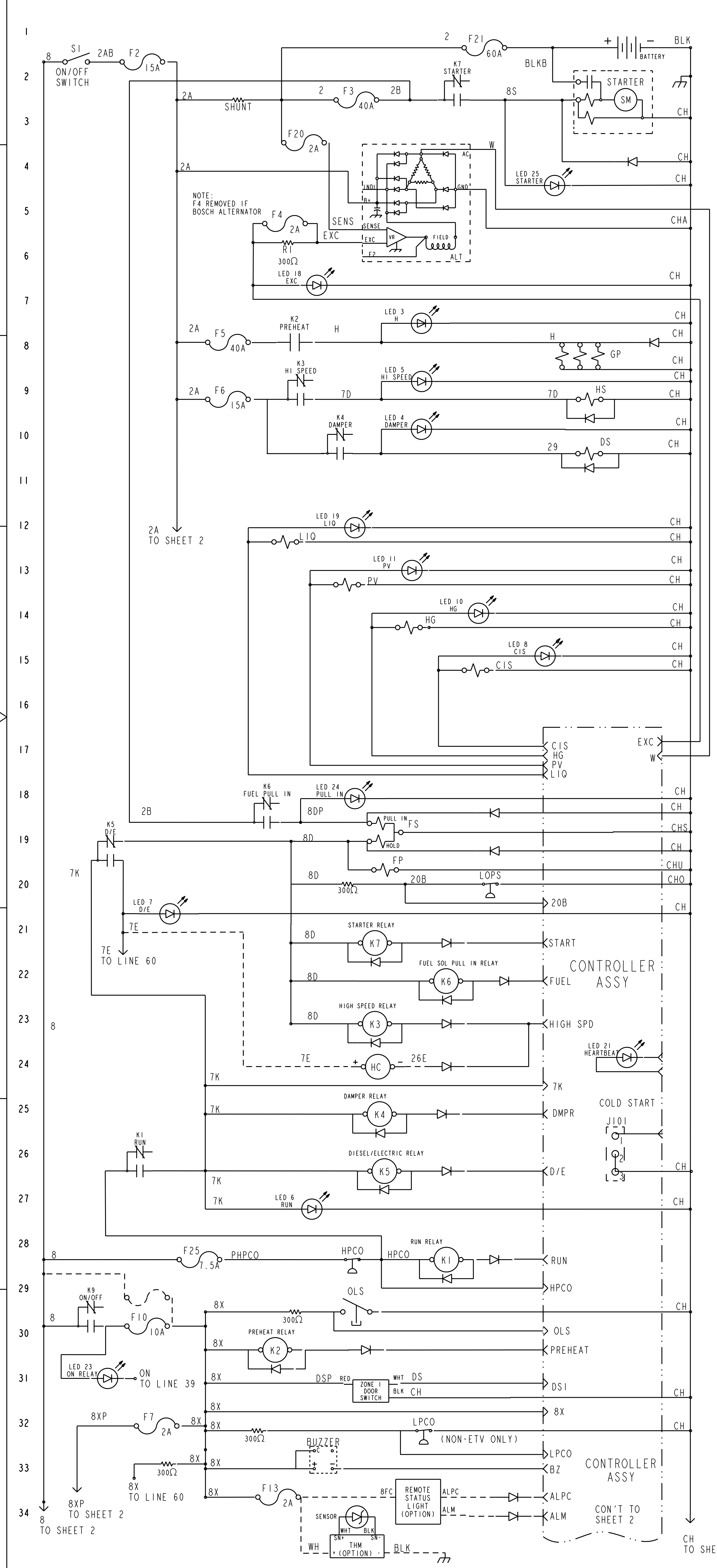

LEGEND	LOCATION
ATS	44
ACM	64, 68
ALT	4
BATTERY	1
BZR	33
C1S	151
CLS	40
CTEMP	42
CTS	47
DAS	52
DLSI	54
DPT	39
DS	10
DSI	31
DTS	46
EH	66
ETV	38
F2-15 A	2
F3-40A	3
F4-2A	5
F5-40A	8
F6-15A	9
F7-2A	32
F8-5A	44
F9-5A	39
F10-10A	29
F12-5A	42
F13-2A	3
F20-2A	34
F21-60A	1
F25-7.5A	28
FP	19
FS	19
FWS	41
GP	8
HC	24, 66
HG	14
HS	9
HMI	40
HPCO	28
J1	63
J101	26
K1	26, 28
K2	8, 30
K3	9, 23
K4	10, 25
K5	19, 26
K6	18, 22
K7	3, 21
K9	27, 39
LED 3	7
LED 4	10
LED 5	9
LED 6	27
LED 7	20
LED 8	15
LED 10	14
LED 11	13
LED 18	6
LED 19	12
LED 21	24
LED 23	31
LED 24	18
LED 25	3
L10	12
LOPS	20
LPCO	32
MCA	60, 63
MCB	60, 61
OL	63
OLS	29
PSM	60
PV	13
RCOM	48
REMOTE	42
RL	34
RTS	45
S1	2
SM	2
SPT	39
SS	2
THM	34
WTS	43

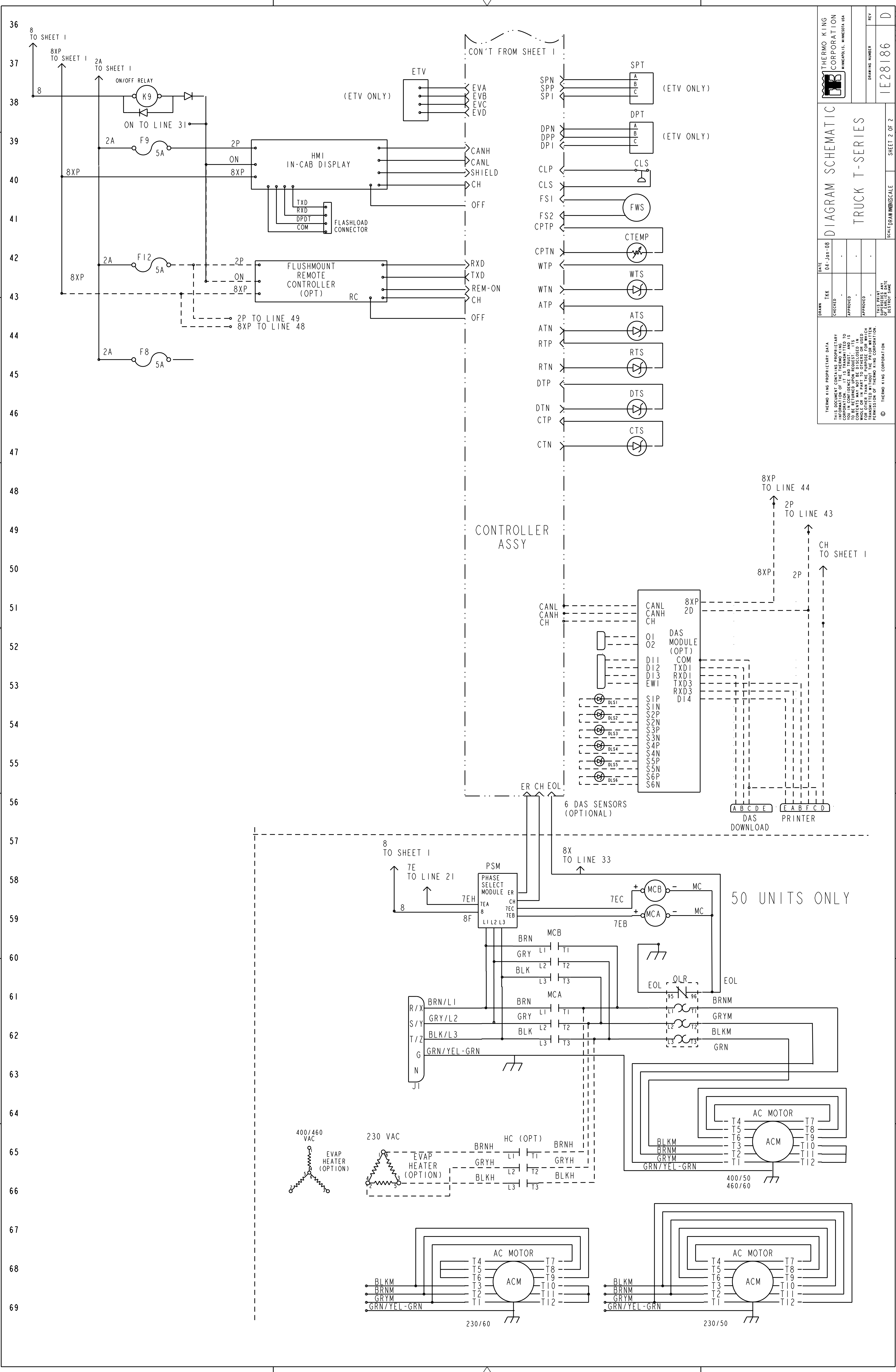

THERMO KING CORPORATION
MINNEAPOLIS, MINNESOTA, USA

DIAGRAM SCHEMATIC
TRUCK T-SERIES

DATE: 04-JUN-08
DRAWN: TKK
CHECKED: []
APPROVED: []
APPROVED: []

SCALE: DRAWING/SCALE SHEET 2 OF 2

DRAWING NUMBER: IE28186
REV: D

THERMO KING PROPRIETARY DATA
THIS INFORMATION IS TRANSMITTED TO YOU BY PERMISSION OF THERMO KING CORPORATION. IT IS TRANSMITTED TO YOU ON THE UNDERSTANDING THAT IT IS TO BE RETURNED UPON REQUEST. THIS INFORMATION IS NOT TO BE REPRODUCED, COPIED, WHOLE OR IN PART, TO OTHERS FOR ANY PURPOSES WITHOUT THE EXPRESS PERMISSION OF THERMO KING CORPORATION.

© THERMO KING CORPORATION