

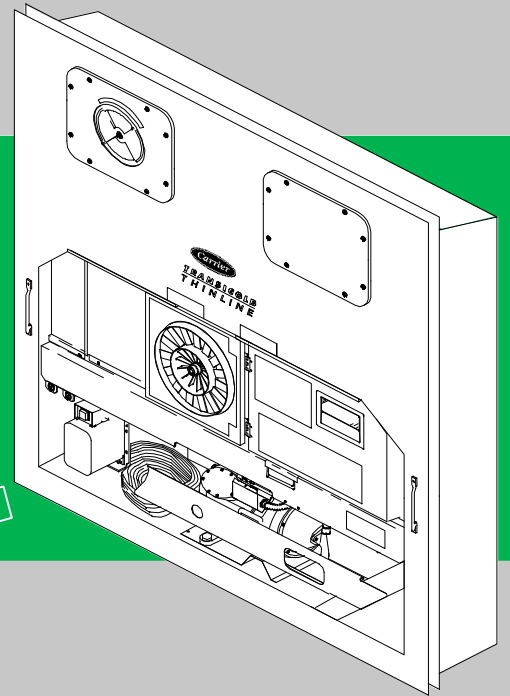

Container Refrigeration

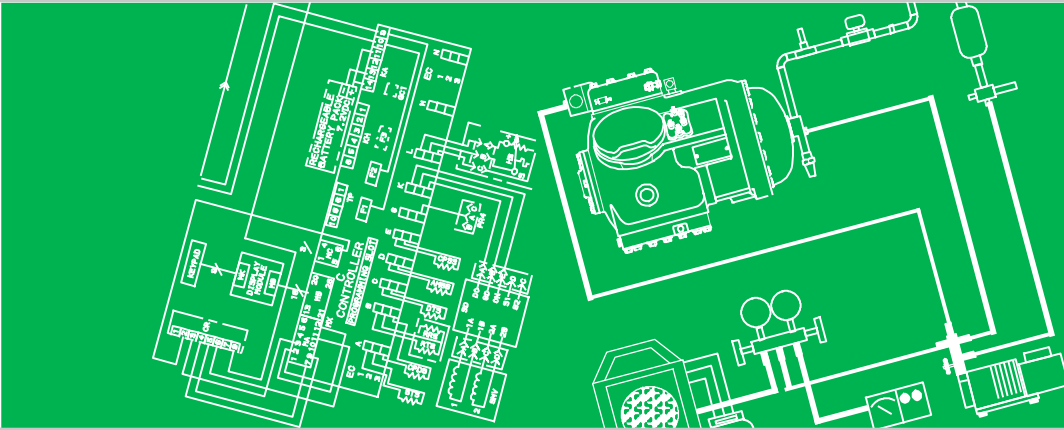

OPERATION AND SERVICE for 69NT40-541-306, 314 & 328 Upflow Container Refrigeration Units



TRANSICOLD

**OPERATION AND SERVICE MANUAL
UPFLOW CONTAINER
REFRIGERATION UNITS**

**Models
69NT-40-541-306, 314 & 328**

TABLE OF CONTENTS

PARAGRAPH NUMBER	Page
GENERAL SAFETY NOTICES	Safety-1
FIRST AID	Safety-1
OPERATING PRECAUTIONS	Safety-1
MAINTENANCE PRECAUTIONS	Safety-1
UNIT LABEL IDENTIFICATION	Safety-1
SPECIFIC WARNING AND CAUTION STATEMENTS	Safety-2
INTRODUCTION	1-1
1.1 INTRODUCTION	1-1
1.2 CONFIGURATION IDENTIFICATION	1-1
1.3 OPTION DESCRIPTION	1-1
1.3.1 Battery	1-1
1.3.2 Dehumidification	1-1
1.3.3 Control Box	1-1
1.3.5 Temperature Readout	1-1
1.3.6 Pressure Readout	1-1
1.3.7 USDA	1-1
1.3.8 Interrogator	1-1
1.3.9 Remote Monitoring	1-1
1.3.10 Communications	1-1
1.3.11 Compressor	1-1
1.3.12 Condenser Coil	1-1
1.3.13 Autotransformer	1-1
1.3.14 Temperature Recorder	1-1
1.3.15 Gutters	1-2
1.3.16 Handles	1-2
1.3.17 Thermometer Port	1-2
1.3.18 Water Cooling	1-2
1.3.19 Back Panels	1-2
1.3.20 460 Volt Cable	1-2
1.3.21 230 Volt Cable	1-2
1.3.22 Cable Restraint	1-2
1.3.23 Upper Air (Fresh Air Make Up)	1-2
1.3.24 Lower Air (Fresh Air Make Up)	1-2
1.3.25 Arctic Mode	1-2
1.3.26 Power Correction	1-2
1.3.27 Evaporator	1-2
1.3.28 Evaporator Fan Operation	1-2
1.3.29 Labels	1-2
1.3.30 Plate Set	1-2
1.3.31 Controller	1-2
1.3.32 Condenser Grille	1-2
1.3.33 Emergency Bypass	1-2

TABLE OF CONTENTS - Continued

PARAGRAPH NUMBER	Page
DESCRIPTION	2-1
2.1 GENERAL DESCRIPTION	2-1
2.1.1 Refrigeration Unit – Front Section	2-1
2.1.2 Fresh Air Makeup Vent	2-1
2.1.3 Evaporator Section	2-2
2.1.4 Compressor Section	2-3
2.1.5 Air-cooled Condenser Section	2-4
2.1.6 Water-cooled Condenser Section	2-5
2.1.7 Control Box Section	2-6
2.1.8 Communications Interface Module	2-6
2.2 REFRIGERATION SYSTEM DATA	2-7
2.3 ELECTRICAL DATA	2-8
2.4 SAFETY AND PROTECTIVE DEVICES	2-9
2.5 REFRIGERATION CIRCUIT	2-10
2.6 ARCTIC OPTION	2-12
MICROPROCESSOR	3-1
3.1 TEMPERATURE CONTROL MICROPROCESSOR SYSTEM	3-1
3.1.1 Keypad	3-2
3.1.2 Display Module	3-2
3.1.3 Controller	3-3
3.2 CONTROLLER SOFTWARE	3-3
3.2.1 Configuration Software (Configuration Variables)	3-3
3.2.2 Operational Software (Function Codes)	3-3
3.3 MODES OF OPERATION	3-4
3.3.1 Temperature Control – Perishable Mode	3-4
3.3.2 Evaporator Fan Operation	3-4
3.3.3 Defrost Interval	3-4
3.3.4 Failure Action	3-4
3.3.5 Generator Protection	3-4
3.3.6 Condenser Pressure Control	3-4
3.3.7 Arctic Mode	3-4
3.3.8 Perishable Mode – Conventional	3-5
3.3.9 Perishable Mode – Economy	3-5
3.3.10 Perishable Mode – Dehumidification	3-5
3.3.11 Perishable, Dehumidification – Bulb Mode	3-5
3.3.12 Temperature Control – Frozen Mode	3-6
3.3.13 Frozen Mode – Conventional	3-6
3.3.14 Frozen Mode – Economy	3-6
3.4 CONTROLLER ALARMS	3-6
3.5 UNIT PRE-TRIP DIAGNOSTICS	3-7

TABLE OF CONTENTS - Continued

PARAGRAPH NUMBER	Page
3.6 DataCORDER	3-7
3.6.1 Description	3-7
3.6.2 DataCORDER Software	3-8
3.6.3 Sensor Configuration (dCF02)	3-8
3.6.4 Logging Interval (dCF03)	3-9
3.6.5 Thermistor Format (dCF04)	3-9
3.6.6 Sampling Type (dCF05 & dCF06)	3-9
3.6.7 Alarm Configuration (dCF07 - dCF10)	3-9
3.6.8 DataCORDER Power-Up	3-9
3.6.9 Pre-Trip Data Recording	3-11
3.6.10 DataCORDER Communications	3-11
3.6.11 USDA Cold Treatment	3-11
3.6.12 USDA Cold Treatment Procedure	3-12
3.6.13 DataCORDER Alarms	3-12
OPERATION	4-1
4.1 INSPECTION (Before Starting)	4-1
4.2 CONNECT POWER	4-1
4.2.1 Connection To 380/460 VAC Power	4-1
4.2.2 Connection to 190/230 VAC Power	4-1
4.3 ADJUST FRESH AIR MAKEUP VENT	4-2
4.3.1 Upper Fresh Air Makeup Vent	4-2
4.3.2 Fresh Air Position Sensor	4-2
4.4 CONNECT WATER-COOLED CONDENSER	4-2
4.5 CONNECT REMOTE MONITORING RECEPTACLE	4-3
4.6 STARTING AND STOPPING INSTRUCTIONS	4-3
4.6.1 Starting the Unit	4-3
4.6.2 Stopping the Unit	4-3
4.7 START-UP INSPECTION	4-3
4.7.1 Physical Inspection	4-3
4.7.2 Check Controller Function Codes	4-3
4.7.3 Start Temperature Recorder	4-3
4.7.4 Complete Inspection	4-3
4.8 PRE-TRIP DIAGNOSIS	4-3
4.9 OBSERVE UNIT OPERATION	4-5
4.9.1 Crankcase Heater	4-5
4.9.2 Probe Check	4-5
4.10 SEQUENCE OF OPERATION	4-7
4.10.1 Sequence of Operation - Perishable Mode Cooling	4-7
4.10.2 Sequence of Operation - Perishable Mode Heating	4-7
4.10.3 Sequence of Operation - Frozen Mode Cooling	4-8
4.10.4 Sequence of Operation - Defrost	4-8

TABLE OF CONTENTS - Continued

PARAGRAPH NUMBER	Page
4.11 EMERGENCY OPERATION (OPTION)	4-9
4.11.1 Emergency Bypass Operation	4-9
4.11.2 Emergency Defrost Operation	4-10
4.12 ARCTIC MODE	4-10
TROUBLESHOOTING	5-1
5.1 UNIT WILL NOT START OR STARTS THEN STOPS	5-1
5.2 UNIT OPERATES LONG OR CONTINUOUSLY IN COOLING	5-1
5.3 UNIT RUNS BUT HAS INSUFFICIENT COOLING	5-2
5.4 UNIT WILL NOT HEAT OR HAS INSUFFICIENT HEATING	5-2
5.5 UNIT WILL NOT TERMINATE HEATING	5-2
5.6 UNIT WILL NOT DEFROST PROPERLY	5-2
5.7 ABNORMAL PRESSURES (COOLING)	5-3
5.8 ABNORMAL NOISE OR VIBRATIONS	5-3
5.9 CONTROLLER MALFUNCTION	5-3
5.10 NO EVAPORATOR AIR FLOW OR RESTRICTED AIR FLOW	5-4
5.11 THERMOSTATIC EXPANSION VALVE MALFUNCTION	5-4
5.12 AUTOTRANSFORMER MALFUNCTION	5-4
5.13 WATER-COOLED CONDENSER OR WATER PRESSURE SWITCH	5-4
SERVICE	6-1
6.1 SECTION LAYOUT	6-1
6.2 SERVICE VALVES	6-1
6.3 MANIFOLD GAUGE SET	6-1
6.4 PUMPING THE UNIT DOWN	6-3
6.5 REFRIGERANT LEAK CHECKING	6-3
6.6 EVACUATION AND DEHYDRATION	6-3
6.6.1 General	6-3
6.6.2 Preparation	6-3
6.6.3 Procedure - Complete System	6-3
6.6.4 Procedure - Partial System	6-4
6.7 REFRIGERANT CHARGE	6-4
6.7.1 Checking the Refrigerant Charge	6-4
6.7.2 Adding Refrigerant to System (Full Charge)	6-4
6.7.3 Adding Refrigerant to System (Partial Charge)	6-4
6.8 COMPRESSOR	6-5
6.8.1 Removal and Replacement of Compressor	6-5
6.8.2 Compressor Disassembly	6-6
6.8.3 Compressor Reassembly	6-8
6.8.4 Preparation	6-8
6.8.5 Installing the Components	6-9
6.8.6 Compressor Oil Level	6-9
6.9 HIGH PRESSURE SWITCH	6-10
6.9.1 Replacing High Pressure Switch	6-10
6.9.2 Checking High Pressure Switch	6-10

TABLE OF CONTENTS - Continued

PARAGRAPH NUMBER	Page
6.10 CONDENSER COIL	6-10
6.11 CONDENSER FAN AND MOTOR ASSEMBLY	6-10
6.12 WATER-COOLED CONDENSER CLEANING	6-11
6.13 FILTER-DRIER	6-12
6.14 THERMOSTATIC EXPANSION VALVE (TXV)	6-12
6.14.1 Checking Superheat	6-13
6.14.2 Expansion Valve Replacement	6-13
6.15 EVAPORATOR COIL AND HEATER ASSEMBLY	6-14
6.15.1 Evaporator Coil Replacement	6-14
6.15.2 Evaporator Heater Replacement	6-14
6.16 EVAPORATOR FAN AND MOTOR ASSEMBLY	6-15
6.17 EVAPORATOR FAN MOTOR CAPACITORS	6-16
6.17.1 When To Check For a Defective Capacitor	6-16
6.17.2 Removing the Capacitor	6-16
6.17.3 Checking the Capacitor	6-16
6.18 EVAPORATOR SECTION CLEANING	6-16
6.19 SUCTION MODULATION VALVE (SMV)	6-17
6.19.1 Pre-check Procedure	6-17
6.19.2 Checking the Stepper Valve	6-18
6.19.3 Checking the Controller	6-18
6.19.4 Emergency Repair Procedures	6-18
6.20 DPRV Check Procedure	6-19
6.21 AUTOTRANSFORMER	6-19
6.22 CONTROLLER	6-19
6.22.1 Handling Controller	6-19
6.22.2 Controller Troubleshooting	6-20
6.22.3 Controller Programming Procedure	6-20
6.22.4 Removing and Installing the Controller	6-21
6.22.5 Battery Replacement	6-21
6.23 TEMPERATURE SENSOR SERVICE	6-21
6.23.1 Sensor Checkout Procedure	6-21
6.23.2 Sensor Replacement	6-22
6.23.3 Sensor Re-Installation	6-23
6.24 VENT POSITION SENSOR (VPS)	6-23
6.25 ELECTRONIC TEMPERATURE RECORDER	6-24
6.25.1 Replacing the Recorder	6-24
6.25.2 Changing the Chart	6-24
6.25.3 Rezeroing the Recording Thermometer	6-24
6.26 MAINTENANCE OF PAINTED SURFACES	6-26
6.27 COMPOSITE CONTROL BOX REPAIRS	6-26
6.28 COMMUNICATIONS INTERFACE MODULE INSTALLATION	6-29
6.29 POWER FACTOR CORRECTOR CAPACITORS (PFC)	6-29
ELECTRICAL WIRING SCHEMATICS	7-1
7.1 INTRODUCTION	7-1

LIST OF ILLUSTRATIONS

FIGURE NUMBER	Page
Figure 2-1 Refrigeration Unit – Front Section	2-1
Figure 2-2 Evaporator Section – UPFLOW Units With Center Access Panel	2-2
Figure 2-3 Compressor Section	2-3
Figure 2-4 Condenser Section	2-4
Figure 2-5 Water-cooled Condenser Section	2-5
Figure 2-6 Control Box Section	2-6
Figure 2-7 Refrigeration Circuit Schematic	2-11
Figure 2-8 Arctic Option	2-12
Figure 3-6 Temperature Control System	3-1
Figure 3-7 Keypad	3-2
Figure 3-8 Display Module	3-2
Figure 3-9 Micro-Link 3 Controller	3-3
Figure 3-10 Standard Configuration Report	3-10
Figure 3-11 Data Reader	3-11
Figure 4-1 Autotransformer	4-1
Figure 4-2 Make Up Air Flow Chart	4-2
Figure 4-3 Controller Operation – Perishable Mode	4-6
Figure 4-4 Controller Operation – Frozen Mode	4-6
Figure 4-5 Perishable Mode Cooling	4-7
Figure 4-6 Perishable Mode Heating	4-7
Figure 4-7 Frozen Mode	4-8
Figure 4-8 Defrost	4-8
Figure 6-1 Service Valve	6-1
Figure 6-2 Manifold Gauge Set	6-1
Figure 6-3 R-134a Manifold Gauge/Hose Set	6-2
Figure 6-4 Refrigeration System Service Connections	6-2
Figure 6-5 Compressor Service Connections	6-4
Figure 6-6 Compressor	6-5
Figure 6-7 Exploded View of Valve Plate	6-6
Figure 6-8 Bottom Plate Removed	6-6
Figure 6-9 Oil Pump and Bearing Head	6-7
Figure 6-10 Low Profile Oil Pump	6-7
Figure 6-11 Motor End Cover	6-7
Figure 6-12 Equalizing Tube and Lock Screw Assembly	6-8
Figure 6-13 Crankshaft Assembly	6-8
Figure 6-14 Suction Valve & Positioning Springs	6-8
Figure 6-15 Piston Ring	6-8
Figure 6-16 High Pressure Switch Testing	6-10
Figure 6-17 Water-Cooled Condenser Cleaning – Forced Circulation	6-12
Figure 6-18 Water-Cooled Condenser Cleaning – Gravity Circulation	6-12
Figure 6-19 Thermostatic Expansion Valve Bulb	6-13
Figure 6-20 Thermostatic Expansion Valve	6-13
Figure 6-21 Hermetic Thermostatic Expansion Valve Brazing Procedure	6-13

LIST OF ILLUSTRATIONS - Continued

FIGURE NUMBER	Page
Figure 6-22 Hermetic Thermostatic Expansion Valve Bulb Location	6-14
Figure 6-23 Evaporator Fan Locating Dimension	6-15
Figure 6-24 Evaporator Fan Assembly	6-15
Figure 6-25 Suction Modulation Valve (SMV)	6-17
Figure 6-26 DPRV Replacement Value Chart	6-19
Figure 6-27 Controller Section of the Control Box	6-19
Figure 6-28 Sensor Types	6-22
Figure 6-29 Sensor and Cable Splice	6-22
Figure 6-30 Return Sensor Positioning	6-23
Figure 6-31 Supply Sensor Positioning	6-23
Figure 6-32 Electronic Partlow Temperature Recorder	6-25
Figure 6-33 Door Hinge Repair	6-27
Figure 6-34 Insert Location	6-28
Figure 6-35 Communications Interface Installation	6-29
Figure 6-36 R-134a Compressor Pressure and Motor Current Curves Versus Ambient Temperature	6-33
Figure 7-1 LEGEND	7-1
Figure 7-2 SCHEMATIC DIAGRAM - Units with Single Evaporator Fan Capability & VPS	7-2
Figure 7-3 UNIT WIRING DIAGRAM - Units with Single Evaporator Fan Capability & VPS	7-3
Figure 7-5 SCHEMATIC DIAGRAM - Units with Normal Evaporator Fan Capability, TransFresh & Crankcase Heater	7-5
Figure 7-6 UNIT WIRING DIAGRAM - Units with Normal Evaporator Fan Capability, TransFresh & Crankcase Heater	7-6

LIST OF TABLES

TABLE NUMBER	Page
Table 2-1 Safety and Protective Devices	2-9
Table 3-1 Keypad Function	3-2
Table 3-2 DataCORDER Configuration Variables	3-8
Table 3-3 DataCORDER Standard Configurations	3-9
Table 3-4 Controller Configuration Variables	3-13
Table 3-5 Controller Function Codes	3-14
Table 3-6 Controller Alarm Indications	3-18
Table 3-7 Controller Pre-Trip Test Codes	3-22
Table 3-8 DataCORDER Function Code Assignments	3-26
Table 3-9 DataCORDER Pre-Trip Result Records	3-27
Table 3-10 DataCORDER Alarm Indications	3-28
Table 6-1 Sensor Temperature/Resistance Chart	6-21
Table 6-2 Crack, Chip and Hole Repair Kit	6-27
Table 6-3 Insert Repair Kit	6-27
Table 6-4 Drill Information	6-27
Table 6-5 Recommended Bolt Torque Values	6-30
Table 6-6 Wear Limits For Compressors	6-30
Table 6-7 Compressor Torque Values	6-31
Table 6-8 R-134a Temperature - Pressure Chart	6-32

SAFETY SUMMARY

GENERAL SAFETY NOTICES

The following general safety notices supplement the specific warnings and cautions appearing elsewhere in this manual. They are recommended precautions that must be understood and applied during operation and maintenance of the equipment covered herein. The general safety notices are presented in the following three sections labeled: First Aid, Operating Precautions and Maintenance Precautions. A listing of the specific warnings and cautions appearing elsewhere in the manual follows the general safety notices.

FIRST AID

An injury, no matter how slight, should never go unattended. Always obtain first aid or medical attention immediately.

OPERATING PRECAUTIONS

Always wear safety glasses.

Keep hands, clothing and tools clear of the evaporator and condenser fans.

No work should be performed on the unit until all circuit breakers, start-stop switches are turned off, and power supply is disconnected.

Always work in pairs. Never work on the equipment alone.

In case of severe vibration or unusual noise, stop the unit and investigate.

MAINTENANCE PRECAUTIONS

Beware of unannounced starting of the evaporator and condenser fans. Do not open the condenser fan grille or evaporator access panels before turning power off, and disconnecting and securing the power plug.

Be sure power is turned off before working on motors, controllers, solenoid valves, and electrical control switches. Tag circuit breaker and power supply to prevent accidental energizing of circuit.

Do not bypass any electrical safety devices, e.g. bridging an overload, or using any sort of jumper wires. Problems with the system should be diagnosed and any necessary repairs performed by qualified service personnel.

When performing any arc welding on the unit or container, disconnect all wire harness connectors from the modules in both control boxes. Do not remove wire harness from the modules unless you are grounded to the unit frame with a static safe wrist strap.

In case of electrical fire, open circuit switch and extinguish with CO₂ (never use water).

UNIT LABEL IDENTIFICATION

To help identify the label hazards on the unit and explain the level of awareness each one carries, an explanation is given with the appropriate consequences:

DANGER – Indicates an immediate hazard that **WILL** result in severe personal injury or death.

WARNING – Warns against hazards or unsafe conditions which **COULD** result in severe personal injury or death.

CAUTION – Warns against potentially hazardous or unsafe practices that could result in minor personal injury, product or property damage.

SPECIFIC WARNING AND CAUTION STATEMENTS

The statements listed below are applicable to the refrigeration unit and appear elsewhere in this manual. These recommended precautions must be understood and applied during operation and maintenance of the equipment covered herein.

WARNING

Beware of unannounced starting of the evaporator and condenser fans. The unit may cycle the fans and compressor unexpectedly as control requirements dictate.

WARNING

Do not attempt to remove power plug(s) before turning OFF start-stop switch (ST), unit circuit breaker(s), and external power source.

WARNING

Make sure the power plugs are clean and dry before connecting to any power receptacle.

WARNING

Make sure that the unit circuit breaker(s) (CB-1 & CB-2) and the START-STOP switch (ST) are in the “O” (OFF) position before connecting to any electrical power source.

WARNING

Never use air for leak testing. It has been determined that pressurized mixtures of refrigerant and air can undergo combustion when exposed to an ignition source.

 **WARNING**

Never use air for leak testing. It has been determined that pressurized, air-rich mixtures of refrigerants and air can undergo combustion when exposed to an ignition source.

 **WARNING**

Make sure power to the unit is OFF and power plug disconnected before replacing the compressor.

 **WARNING**

Do not use a nitrogen cylinder without a pressure regulator. Do not use oxygen in or near a refrigeration system as an explosion may occur.

 **WARNING**

Do not open the condenser fan grille before turning power OFF and disconnecting power plug.

 **WARNING**

Oakite No. 32 is an acid. Be sure that the acid is slowly added to the water. **DO NOT PUT WATER INTO THE ACID.** This will cause spattering and excessive heat.

 **WARNING**

Wear rubber gloves and wash the solution from the skin immediately if accidental contact occurs. Do not allow the solution to splash onto concrete.

 **WARNING**

Always turn OFF the unit circuit breakers (CB-1 & CB-2) and disconnect main power supply before working on moving parts.

 **WARNING**

Make sure power to the unit is OFF and power plug disconnected before servicing capacitor(s).

 **WARNING**

With power OFF discharge the capacitor before disconnecting the circuit wiring.

 **WARNING**

The unit power plug must be disconnected to remove power from circuit breaker CB1

 **WARNING**

Make sure power to the unit is OFF and power plug disconnected before removing capacitor(s).

 **WARNING**

Before removing the capacitors, the terminals must be checked for voltage with a multimeter. The discharge resistors installed on the unit (capacitors) should bring the voltage to a safe level in a minute. However, there may be a broken resistor that retains voltage for a longer period. Therefore, it is highly recommended to wait 15 minutes and to check for voltage.

 **CAUTION**

Do not remove wire harnesses from controller unless you are grounded to the unit frame with a static safe wrist strap.

 **CAUTION**

Unplug all controller wire harness connectors before performing arc welding on any part of the container.

 **CAUTION**

Pre-trip inspection should not be performed with critical temperature cargoes in the container.

 **CAUTION**

When Pre-Trip key is pressed, dehumidification and bulb mode will be deactivated. At the completion of Pre-Trip activity, dehumidification and bulb mode must be reactivated.

 **CAUTION**

When condenser water flow is below 11 lpm (3 gpm) or when water-cooler is not in use, the CFS switch **MUST** be set to position “1” or the unit will not operate properly.

 **CAUTION**

Pre-trip inspection should not be performed with critical temperature cargoes in the container.

 **CAUTION**

When Pre-Trip key is pressed, dehumidification and bulb mode will be deactivated. At the completion of Pre-Trip activity, dehumidification and bulb mode must be reactivated.

 **CAUTION**

When a failure occurs during automatic testing, the unit will suspend operation awaiting operator intervention.

 **CAUTION**

When Pre-Trip test Auto 2 runs to completion without being interrupted, the unit will terminate pre-trip and display “Auto 2” “end.” The unit will suspend operation until the user depresses the ENTER key!

 **CAUTION**

The unit will remain in the full cooling mode as long as the emergency bypass switch is in the BYPASS position and the MODE SWITCH is in the FULL COOL position. If the cargo may be damaged by low temperatures, the operator must monitor container temperature and manually cycle operation as required to maintain temperature within required limits.

 **CAUTION**

The unit will remain in the DEFROST mode as long as the emergency defrost switch is in the DEFROST position. To prevent cargo damage, the operator must monitor container temperature and manually cycle operation as required to maintain temperature within required limits.

 **CAUTION**

To prevent trapping liquid refrigerant in the manifold gauge set, be sure set is brought to suction pressure before disconnecting.

 **WARNING**

Before disassembly of any external compressor component, make sure to relieve possible internal pressure by loosening the bolts and tapping the component with a soft hammer to break the seal.

 **CAUTION**

Removing the compressor motor press-fit stator in the field is not recommended. The rotor and stator are a matched pair and should not be separated.

 **CAUTION**

The copper tube that connects to the oil suction strainer extends out the bottom with the bottom plate removed. Take precautions to avoid bending or breaking it while changing crankcase positions.

 **CAUTION**

Ensure that the thrust washer does not fall off dowel pins while installing oil pump.

 **CAUTION**

The set screw on the crankshaft must be removed for this type of oil pump. (See Figure 6-9.)

 **CAUTION**

Use only Carrier Transicold approved Polyol Ester Oil (POE) - Castrol-Icematic SW20 compressor oil with R-134a. Buy in quantities of one quart or smaller. When using this hygroscopic oil, immediately reseal. Do not leave container of oil open or contamination will occur.

 **CAUTION**

Take necessary steps (place plywood over coil or use sling on motor) to prevent motor from falling into condenser coil.

 **CAUTION**

DO NOT disassemble piston from NEW suction modulating valve powerhead assembly. Doing so may result in damage to piston.

 **CAUTION**

Do not remove wire harnesses from controller unless you are grounded to the unit frame with a static safe wrist strap.

 **CAUTION**

Unplug all controller connectors before performing arc welding on any part of the container.

 **CAUTION**

The unit must be OFF whenever a programming card is inserted or removed from the controller programming port.

 **CAUTION**

Do not allow moisture to enter wire splice area as this may affect the sensor resistance.

 **CAUTION**

Do not allow the recorder stylus to snap back down. The stylus arm base is spring-loaded, and damage may occur to the chart or the stylus force may be altered.

 **CAUTION**

DO NOT move the stylus arm up and down on the chart face. This will result in damage to the stylus motor gear.

SECTION 1

INTRODUCTION

1.1 INTRODUCTION

The Carrier Transicold Upflow container models 69NT40-541-314 series units are made of lightweight aluminum frame construction. They are designed to fit in the front of a container and serve as the container's front wall.

They are one piece, self-contained, all-electric units, which includes cooling and heating systems to provide precise temperature control.

The units are supplied with a complete charge of refrigerant R-134a and compressor lubricating oil, and are ready for operation upon installation. Forklift pockets are provided for unit installation and removal.

The base unit operates on nominal 380/460 volt, 3-phase, 50/60 hertz power. An optional autotransformer may be fitted to allow operation on nominal 190/230, 3-phase, 50/60 hertz power. Power for the control system is provided by a transformer, which steps the supply power down to 18 and 24 volts, single phase.

The controller is a Carrier Transicold Micro-Link 3 microprocessor. The controller will operate automatically to select cooling, holding or heating as required to maintain the desired set point temperature within very close limits. The unit may also be equipped with a mechanical or electronic temperature recorder.

The controller has a keypad and display for viewing or changing operating parameters. The display is also equipped with lights to indicate various modes of operation.

1.2 CONFIGURATION IDENTIFICATION

Unit identification information is provided on a plate located near the compressor. The plate provides the unit model number, the unit serial number and the unit parts identification number (PID). The model number identifies the overall unit configuration while the PID provides information on specific optional equipment, factory provision to allow for field installation of optional equipment and differences in detailed parts.

1.3 OPTION DESCRIPTION

Various options may be factory or field equipped to the base unit. These options are listed in the tables and described in the following subparagraphs.

1.3.1 Battery

The refrigeration controller may be fitted with standard replaceable batteries or a rechargeable battery pack.

1.3.2 Dehumidification

The unit may be fitted with a humidity sensor. This sensor allows setting of a humidity set point in the controller. In the dehumidification mode the controller will operate to reduce internal container moisture level.

1.3.3 Control Box

Units are equipped with either an aluminum or composite material box, and may be fitted with a lockable door.

1.3.4 Display Module

The unit may be fitted with a backlit Liquid Crystal Display (LCD) or a Light Emitting Diode (LED) Display.

1.3.5 Temperature Readout

The unit may be fitted with suction and discharge temperature sensors. The sensor readings may be viewed on the controller display.

1.3.6 Pressure Readout

The unit may be fitted with suction and discharge pressure gauges, or suction and discharge transducers or no pressure readout. The transducer readings may be viewed on the controller display.

1.3.7 USDA

The unit may be supplied with fittings for additional temperature probes, which allow recording of USDA Cold Treatment data by the integral DataCORDER function of the Micro-Link refrigeration controller.

1.3.8 Interrogator

Units that use the DataCORDER function are fitted with interrogator receptacles for connection of equipment to download the recorded data. Two receptacles may be fitted; one accessible from the front of the container and the other mounted inside the container (with the USDA receptacles).

1.3.9 Remote Monitoring

The unit may be fitted with a remote monitoring receptacle. This item allows connection of remote indicators for COOL, DEFROST and IN RANGE. Unless otherwise indicated, the receptacle is mounted at the control box location.

1.3.10 Communications

The unit may be fitted with a communications interface module. The communications interface module is a slave module, which allows communication with a master central monitoring station. The module will respond to communication and return information over the main power line. Refer to the ship master system technical manual for further information.

1.3.11 Compressor

The unit is fitted with a single speed reciprocating compressor.

1.3.12 Condenser Coil

The unit is fitted with a 3-row coil using 7mm tubing.

1.3.13 Autotransformer

An autotransformer may be provided to allow operation on 190/230, 3-phase, 50/60 hertz power. The autotransformer raises the supply voltage to the nominal 380/460 volt power required by the base unit. The autotransformer may also be fitted with an individual circuit breaker for the 230 volt power.

If the unit is equipped with an autotransformer and the Low Data Rate Communications Interface Module, the autotransformer will be fitted with a transformer bridge unit (TBU) to assist in communications.

1.3.14 Temperature Recorder

The unit may be fitted with an electronic temperature recording device.

1.3.15 Gutters

Rain gutters may be fitted over the control box and recorder section to divert rain away from the controls. The different gutters include standard length bolted gutters, extended length gutters, and riveted gutters.

1.3.16 Handles

The unit may be equipped with handles to facilitate access to stacked containers. These handles may include fixed handles (located at the sides of the unit) and/or a hinged handle at the center (attached to the condenser coil cover).

1.3.17 Thermometer Port

The unit may be fitted with ports in the front of the frame for insertion of a thermometer to measure supply and/or return air temperature. If fitted, the port(s) will require a cap and chain.

1.3.18 Water Cooling

The refrigeration system may be fitted with a water-cooled condenser. The condenser is constructed using copper-nickel tube for seawater applications. The water-cooled condenser is in series with the air-cooled condenser and replaces the standard unit receiver. When operating on the water-cooled condenser, the condenser fan can be deactivated by either a water pressure switch or condenser fan switch. Depending on the unit's configuration and the compressor discharge temperature, the condenser fan may also be activated during water-cooled condenser operation.

1.3.19 Back Panels

Back panel designs that may be fitted include panels of aluminum and stainless steel. Panels may have access doors and/or hinge mounting.

1.3.20 460 Volt Cable

Various power cable and plug designs are available for the main 460 volt supply. The plug options tailor the cables to each customer's requirements.

1.3.21 230 Volt Cable

Units equipped with an autotransformer require an additional power cable for connection to the 230 volt source. Various power cable and plug designs are available. The plug options tailor the cables to each customer's requirements.

1.3.22 Cable Restraint

Various designs are available for storage of the power cables. These options are variations of the compressor section front cover.

1.3.23 Upper Air (Fresh Air Make Up)

The unit may be fitted with an upper fresh air makeup assembly. The fresh air makeup assembly is available with a vent positioning sensor (VPS) and may also be fitted with screens.

1.3.24 Lower Air (Fresh Air Make Up)

The unit may be fitted with a lower fresh air makeup assembly. The fresh air makeup assembly is available with a vent positioning sensor (VPS) and may also be fitted with screens.

1.3.25 Arctic Mode

To improve operation in cold ambients, the unit may be fitted with a crankcase heater. The crankcase heater is operated any time the unit is under power and the compressor is not running. The purpose of the heater is to warm the compressor oil and boil off any liquid refrigerant that may be present in the crankcase.

1.3.26 Power Correction

The unit may be fitted with a set of power factor correction capacitors to assist in correction of imbalance in current draw by the compressor.

1.3.27 Evaporator

The evaporator section is equipped with a hermetic thermal expansion valve and a heat exchanger. The unit may have six heaters.

1.3.28 Evaporator Fan Operation

Two evaporator fan motor operation systems are available. On units with Normal Evaporator Fan Operation, opening of an evaporator fan internal protector will shut down the unit. On units equipped with single evaporator fan capability, additional relays are installed to allow the unit to continue to operate on a single fan.

1.3.29 Labels

Operating instruction and function code listing labels will differ depending on the options installed. For example, additional operating instructions are required to describe start-up of a unit equipped with an autotransformer. Where the labels are available with additional languages, they are listed in the parts list.

1.3.30 Plate Set

Each unit is equipped with a tethered set of wiring schematic and wiring diagram plates. The plate sets are ordered using a seven-digit base part number and a two-digit dash number.

1.3.31 Controller

Two different controllers are available:

1. Remanufactured - Controller is the equivalent of a new OEM controller and is supplied with a 12 month warranty.

2. Repaired - Controller has had previous faults repaired and upgraded with the latest software.

Note: Repaired controllers are NOT to be used for warranty repairs. Only full OEM remanufactured controllers are to be used.

Controllers will be factory equipped with the latest version of operational software, but will NOT be configured for a specific model number and will need to be configured at the time of installation or sale.

1.3.32 Condenser Grille

Two styles of condenser grilles are available - direct bolted grilles and hinged grilles.

1.3.33 Emergency Bypass

The unit may be equipped with switches to allow emergency bypass of the controller. The EMERGENCY BYPASS switch functions to bypass the controller in the event of controller failure. The EMERGENCY DEFROST switch functions to bypass all controls and place the unit in the defrost mode.

SECTION 2

DESCRIPTION

2.1 GENERAL DESCRIPTION

2.1.1 Refrigeration Unit - Front Section

The unit is designed so that the majority of the components are accessible from the front (see Figure 2-1). The unit model number, serial number, and

parts identification number can be found on the serial plate to the left of the compressor.

2.1.2 Fresh Air Makeup Vent

The function of the upper or lower makeup air vent is to provide ventilation for commodities that require fresh air circulation.

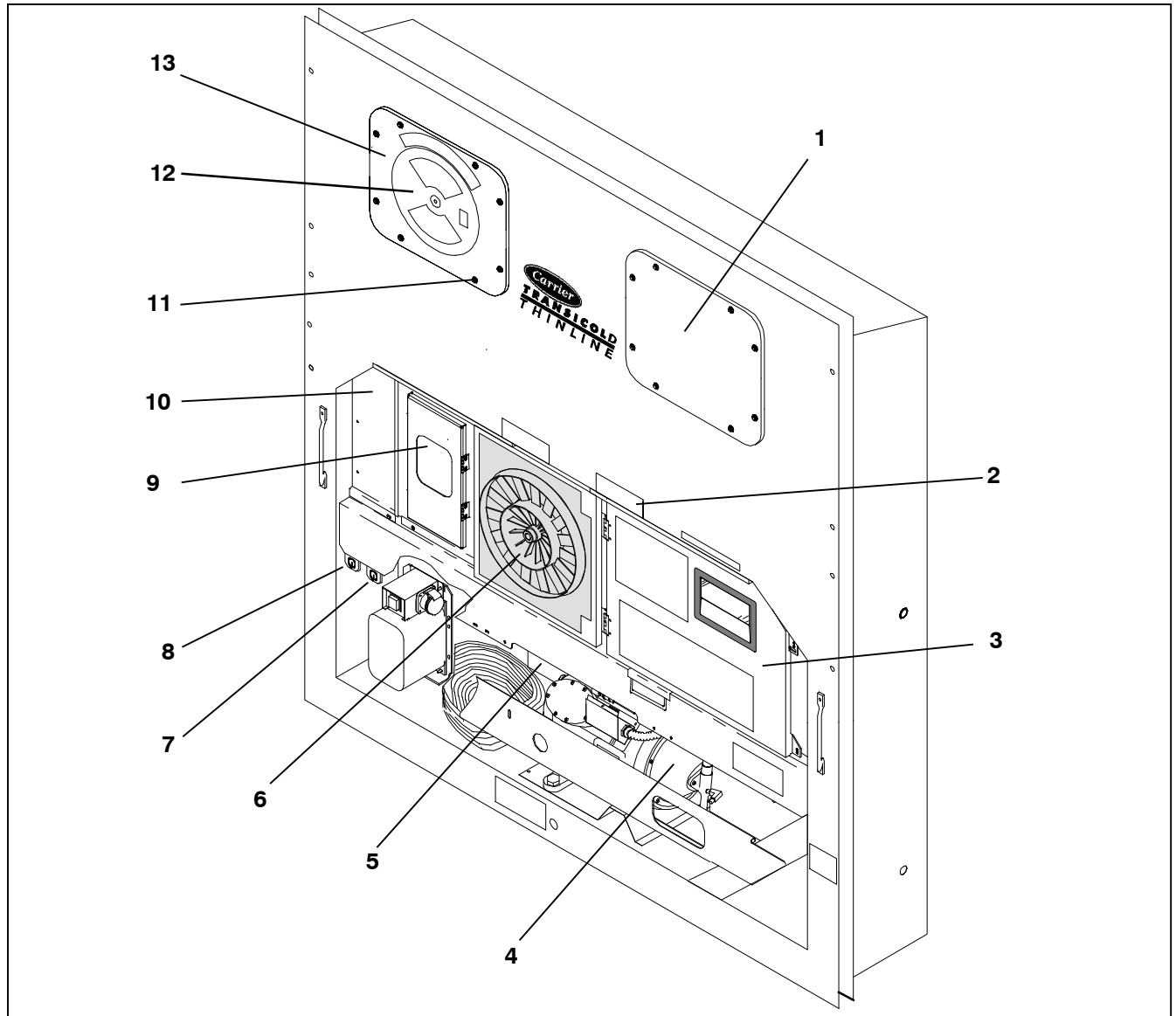

- | | |
|--|--|
| 1. Access Panel (Evaporator Fan #1)/Thermostatic Expansion Valve / HTT | 8. Interrogator Connector (Front Left) |
| 2. Fork Lift Pockets | 9. Temperature Recorder |
| 3. Control Box | 10. Lower Fresh Air Makeup Vent Location (Blank Cover Shown) |
| 4. Compressor, Reciprocating | 11. TIR (Transports Internationaux Routiers) Sealing Provisions - Typical All Panels |
| 5. Unit Serial Number, Model Number, and Parts Identification Number (PID) Plate | 12. Upper Fresh Air Makeup Vent |
| 6. Condenser Fan | 13. Access Panel (Evaporator Fan #2)/ Humidity Sensor / Supply Temperature Sensor |
| 7. TransFRESH Communications Connector | |

Figure 2-1 Refrigeration Unit - Front Section

2.1.3 Evaporator Section

The evaporator section (Figure 2-2) contains the supply temperature sensor, humidity sensor, thermostatic expansion valve, dual-speed evaporator fans (EM1 and EM2), evaporator coil and heaters, defrost temperature sensor, heat termination thermostat, and heat exchanger.

The evaporator fans circulate air through the container by pulling it from the bottom of the unit, directing it through the evaporator coil where it is heated or cooled, and discharging it at the top.

The evaporator components are accessible by removing the upper rear panel (as shown in Figure 2-2).

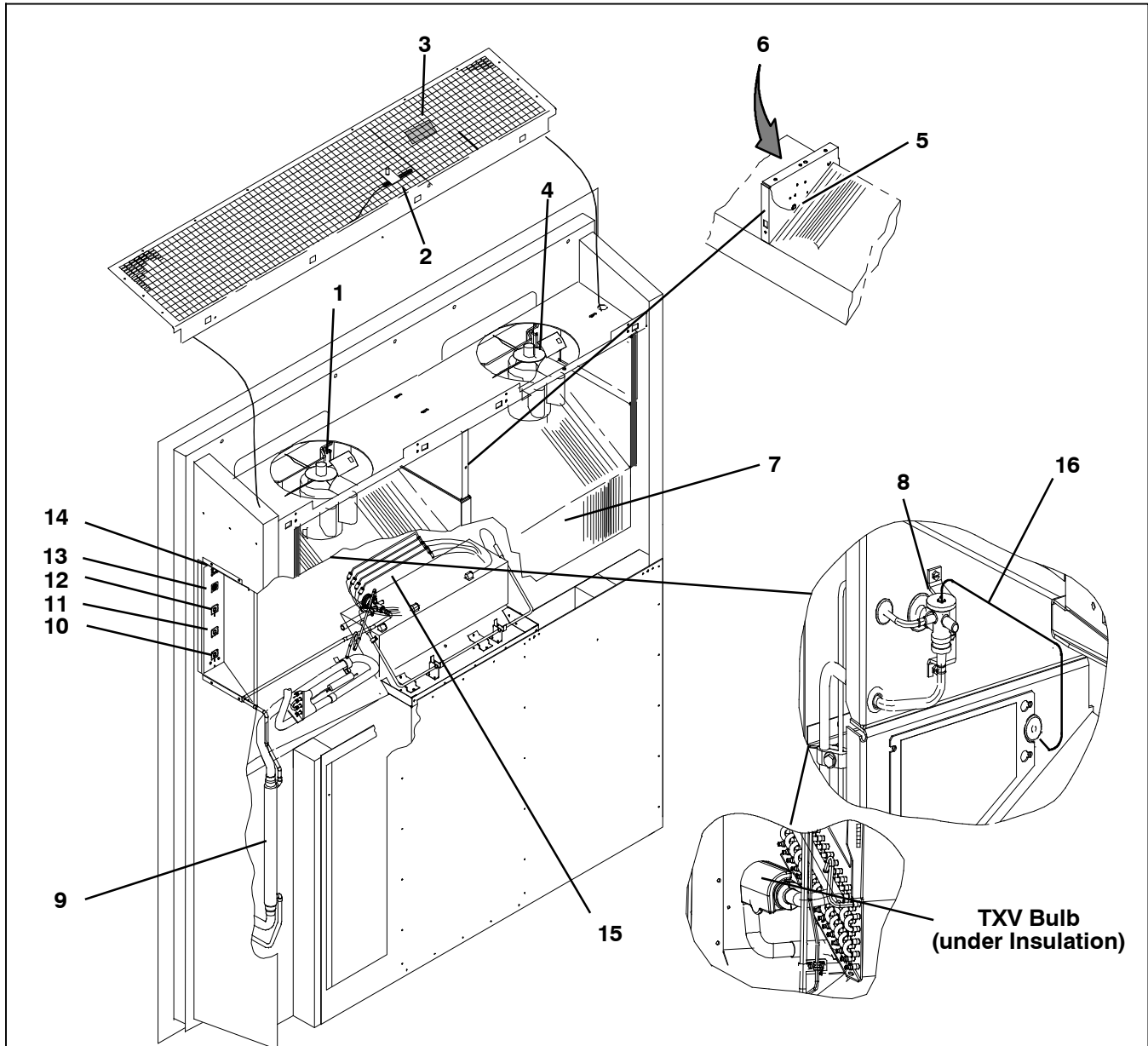

- | | |
|--|-----------------------------------|
| 1. Evaporator Fan Motor #1 | 9. Heat Exchanger |
| 2. Supply Recorder Sensor (SRS) /
Supply Temperature Sensor (STS) | 10. Interrogator Connector (Rear) |
| 3. Humidity Sensor | 11. USDA Probe Receptacle PR2 |
| 4. Evaporator Fan Motor #2 | 12. USDA Probe Receptacle PR1 |
| 5. Defrost Temperature Sensor | 13. USDA Probe Receptacle PR3 |
| 6. Heater Termination Thermostat | 14. Cargo Probe Receptacle PR4 |
| 7. Evaporator Coil | 15. Evaporator Coil Heaters |
| 8. Hermetic Thermostatic Expansion Valve (TXV) | 16. TXV Bulb Routing |

Figure 2-2 Evaporator Section - UPFLOW Units With Center Access Panel

2.1.4 Compressor Section

The reciprocating compressor section includes the compressor (with high pressure switch), power cable storage compartment, and autotransformer.

This section also contains the suction modulating valve,

discharge pressure regulating valve, discharge temperature sensor, and discharge/suction pressure transducers.

The return temperature sensor, return recorder sensor, and ambient sensor are located at the right side of the compressor.

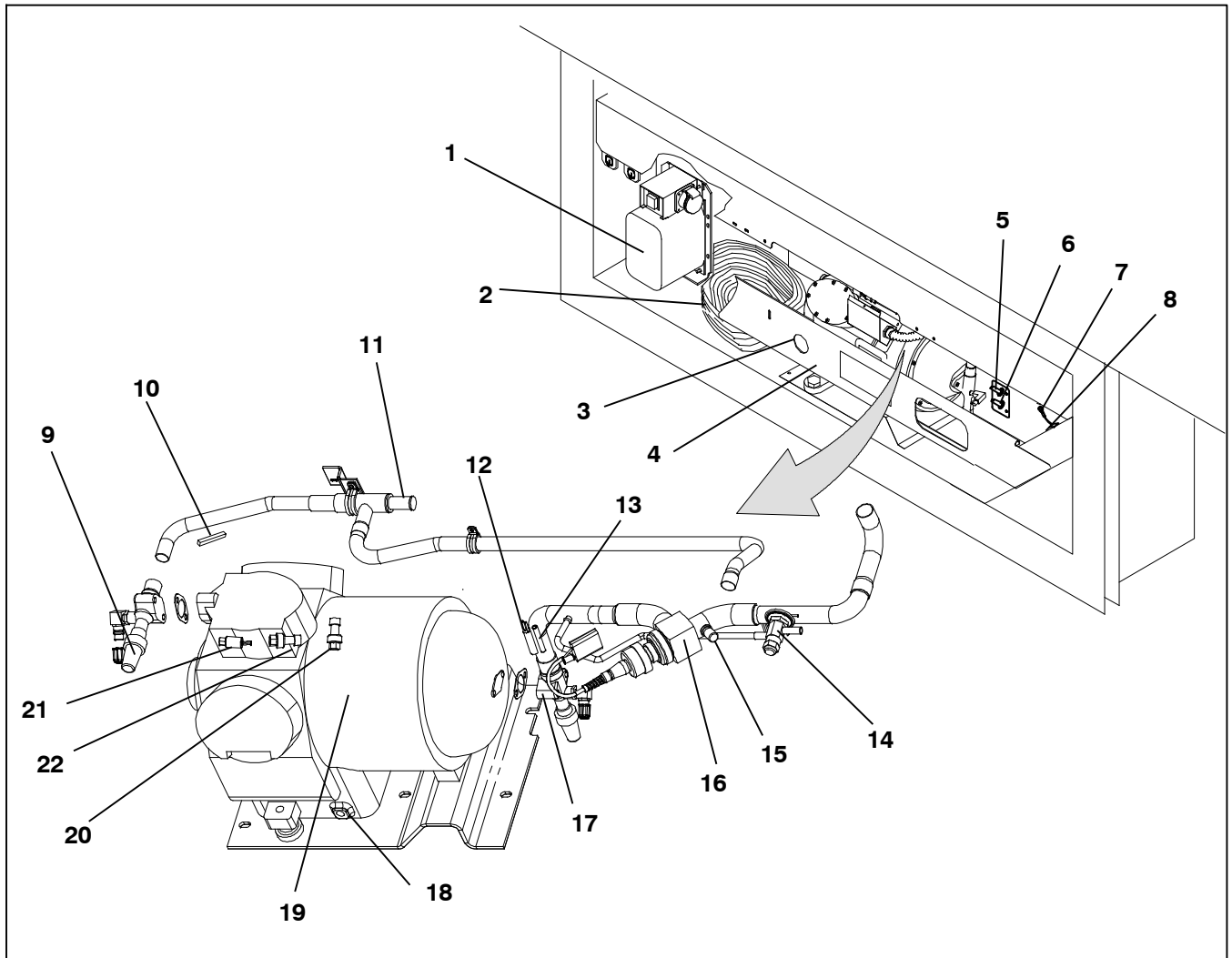

- | | |
|---|-----------------------------------|
| 1. Autotransformer | 12. Suction Temperature Sensor |
| 2. Power Cables and Plug | 13. Quench Valve Temperature Bulb |
| 3. Compressor Sight Glass View Port | 14. Quench Valve |
| 4. Compressor Guard | 15. Access Valve |
| 5. Return Temperature Sensor | 16. Suction Modulating Valve |
| 6. Return Recorder Sensor | 17. Suction Service Valve |
| 7. Ambient Sensor | 18. Compressor Crankcase Heater |
| 8. Return Air Thermometer Port | 19. Compressor Motor |
| 9. Discharge Service Valve | 20. Suction Pressure Transducer |
| 10. Discharge Temperature Sensor | 21. High Pressure Switch |
| 11. Discharge Pressure Regulating Valve | 22. Discharge Pressure Transducer |

Figure 2-3 Compressor Section

2.1.5 Air-cooled Condenser Section

The air-cooled condenser section (Figure 2-4) consists of the condenser fan, condenser coil, receiver with sight glass/moisture indicator, quench valve, manual liquid

line valve, filter-drier, condenser pressure transducer, and fusible plug.

The condenser fan pulls air in through the bottom of the coil and discharges it horizontally out through the condenser fan grille.

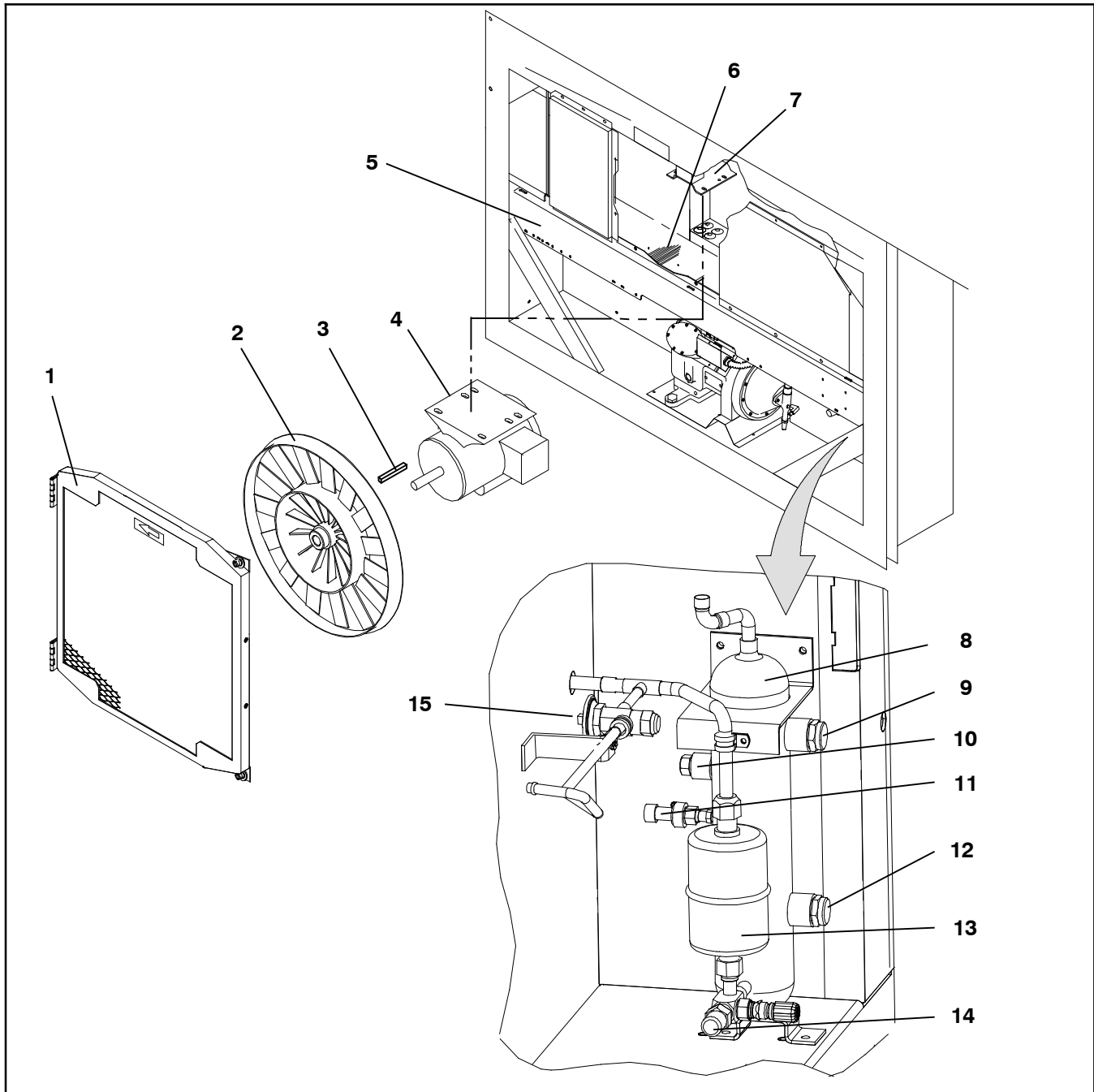

- | | |
|-------------------------------------|---|
| 1. Grille and Venturi Assembly | 9. Sight Glass |
| 2. Condenser Fan | 10. Fusible Plug (Rupture Disc - Alternate) |
| 3. Key | 11. Condenser Pressure Transducer |
| 4. Condenser Fan Motor | 12. Sight Glass/Moisture Indicator |
| 5. Condenser Coil Cover | 13. Filter-Drier |
| 6. Condenser Coil | 14. Liquid Line Service Valve |
| 7. Condenser Motor Mounting Bracket | 15. Quench Valve |
| 8. Receiver | |

Figure 2-4 Condenser Section

2.1.6 Water-cooled Condenser Section

The water-cooled condenser section (Figure 2-5) consists of a water-cooled condenser, sight glass,

quench expansion valve, rupture disc, condenser pressure transducer, filter-drier, water couplings, and water pressure switch. The water-cooled condenser replaces the standard unit receiver.

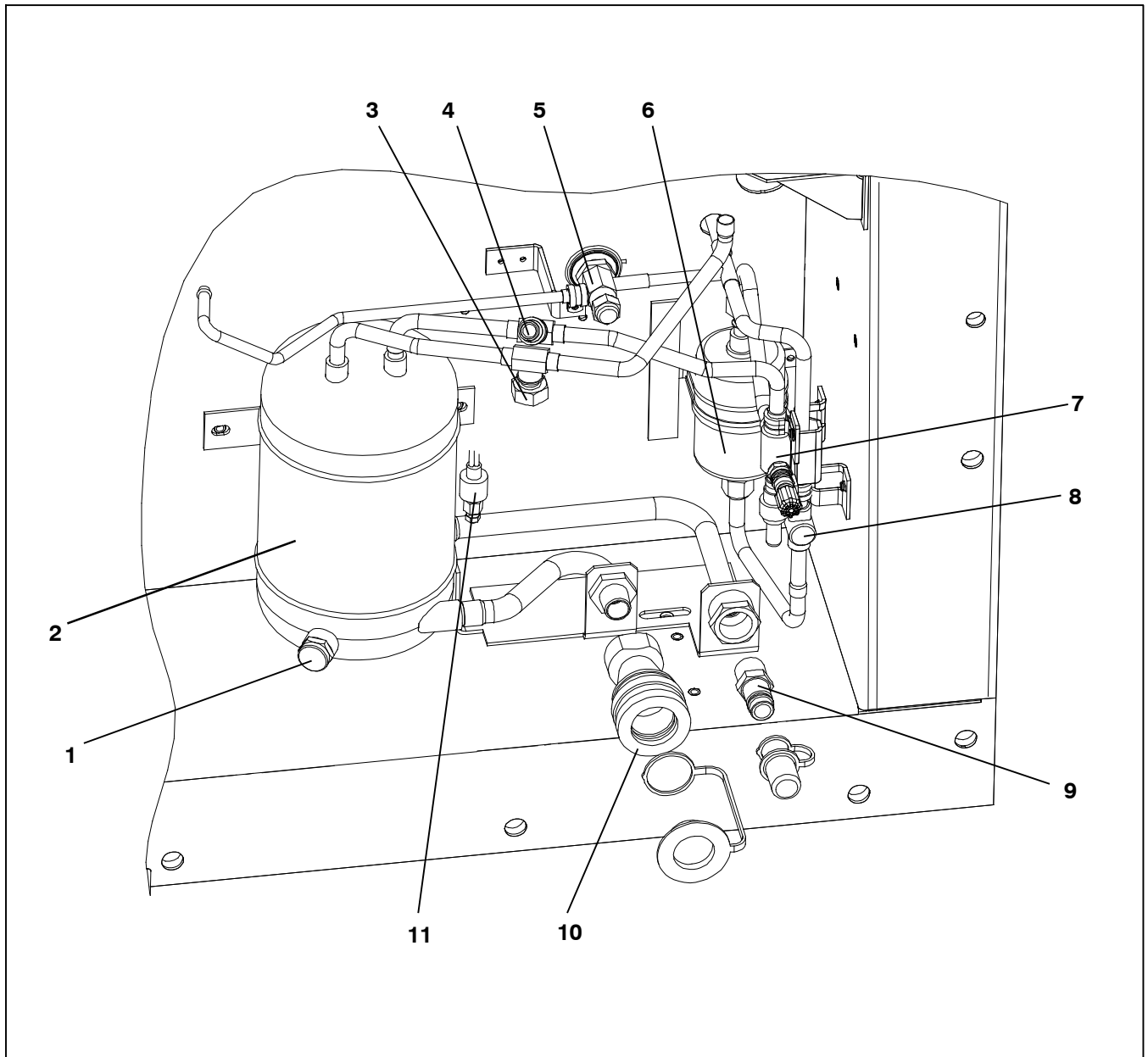

- | | |
|----------------------------------|--|
| 1. Sight Glass | 7. Liquid Line Service Valve |
| 2. Water-Cooled Condenser | 8. Moisture/Liquid Indicator |
| 3. Rupture Disc | 9. Coupling (Water In) |
| 4. Condenser Pressure Transducer | 10. Self Draining Coupling (Water Out) |
| 5. Quench Valve | 11. Water Pressure Switch |
| 6. Filter-Drier | |

Figure 2-5 Water-cooled Condenser Section

2.1.7 Control Box Section

The control box (Figure 2-6) includes the manual operation switches, circuit breaker (CB-1), compressor, fan and heater contactors, control power transformer, fuses, keypad, display module, current sensor module, controller module and the communications interface module.

2.1.8 Communications Interface Module

The communications interface module is a slave module, which allows communication with a master central monitoring station. The module will respond to communication, and return information over the main power line. Refer to the master system technical manual for further information.

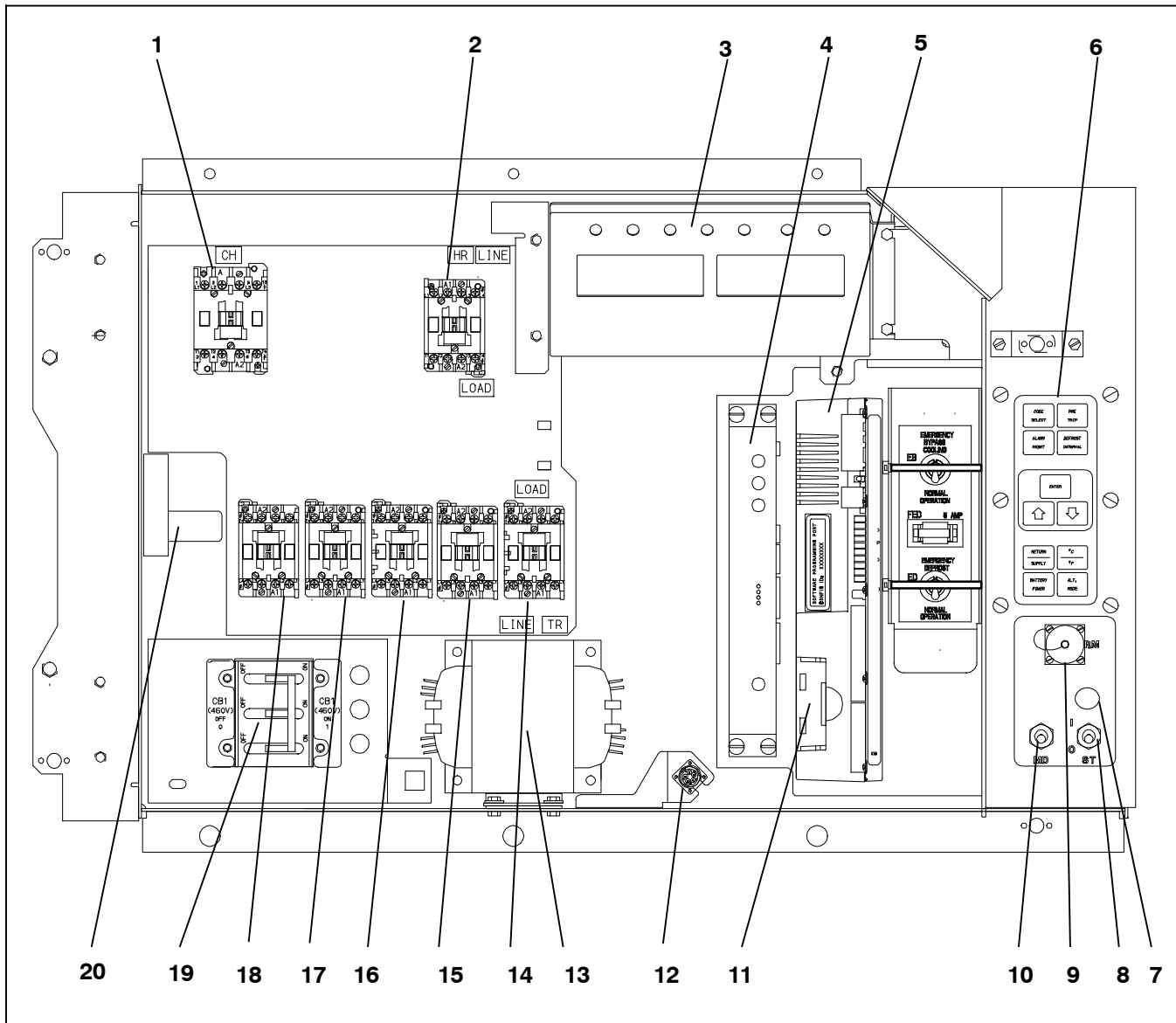

- | | |
|--|---|
| 1. Compressor Contactor | 11. Controller Battery Pack |
| 2. Heater Contactor | 12. Interrogator Connector (Box Location) |
| 3. Display Module | 13. Control Transformer |
| 4. Communications Interface Module | 14. Evaporator Fan Contactor - E1 |
| 5. Controller/DataCORDER Module (Controller) | 15. Evaporator Fan Contactor - S1 |
| 6. Key Pad | 16. Evaporator Fan Contactor - S2 or EF |
| 7. Emergency Defrost Light | 17. Evaporator Fan Contactor - E2 or ES |
| 8. Start-Stop Switch | 18. Condenser Fan Contactor |
| 9. Remote Monitoring Receptacle | 19. Circuit Breaker - 460V |
| 10. Manual Defrost Switch | 20. Current Sensor Module |

Figure 2-6 Control Box Section

2.2 REFRIGERATION SYSTEM DATA

a. Compressor/Motor Assembly	Number of Cylinders	6
	Model	06DR
	CFM	41
	Weight (Dry)	118 kg (260 lb)
	Approved Oil	Castrol Icematic
	Oil Charge degrees	3.6 liters (7.6 U.S. pints)
	Oil Sight Glass	The oil level range, with the compressor off, should be between the bottom and one-eighth level of the sight glass.
b. Expansion Valve Superheat	Verify at -18 °C (0°F) container box temperature	4.5 to 6.7°C (8 to 12°F)
c. Heater Termination Thermostat	Opens	54° (+/-) C = 130° (+/-) F
	Closes	38° (+/- 4) C = 100° (+/- 7) F
d. High Pressure Switch	Cutout	25 (+/- 1.0) kg/cm ² = 350 (+/- 10) psig
	Cut-In	18 (+/- 0.7) kg/cm ² = 250 (+/- 10) psig
e. Refrigerant Charge	Unit Configuration	Charge Requirements - R-134a 3 row condenser
	Water-Cooled Condenser	4.9 kg (10.75 lbs)
	Receiver	4.0 kg (8.75 lbs)
NOTE		
When replacing the following components (f.), (g.) and (h.), refer to the installation instructions included with the replacement part for additional information.		
f. Fusible Plug*	Melting point	99°C = (210° F)
	Torque*	6.2 to 6.9 mkg (45 to 50 ft-lbs)
g. Sight Glass/Moisture Indicator	Torque	8.9 to 9.7 mkg (65 to 70 ft-lbs)
h. Rupture Disc	Bursts at	35 +/- 5% kg/cm ² = (500 +/- 5% psig)
	Torque (P/N 14-00215-03)	1.4 to 2 mkg (10 to 15 ft-lbs)
i. Condenser Pressure Transducer	Condenser Fan Starts	The condenser fan will start if the condenser pressure is greater than 14.06 kg/cm ² (200 psig) OR the condenser fan is OFF for more than 60 seconds.
	Condenser Fan Stops	The condenser fan will stop if the condenser pressure is less than 9.14 kg/cm ² (130 psig) AND the condenser fan remains ON for at least 30 seconds.
j. Unit Weight	Refer to unit model number plate.	
k. Water Pressure Switch	Cut-In	0.5 +/- 0.2 kg/cm ² 3-row condenser (7 +/- 3 psig)
	Cutout	1.6 +/- 0.4 kg/cm ² (22 +/- 5 psig)
l. Discharge Pressure Regulating Valve	Factory Setting	32.7 +/- 2.5 kg/cm ² (72 +/- 5.5 psig)

* Rupture Disc, part number 14 -00215 -04 may be installed as an alternate for the receiver mounted fusible plug.

2.3 ELECTRICAL DATA

a. Circuit Breaker	CB-1 Trips at	29 amps	
	CB-2 (50 amp) Trips at	62.5 amps	
	CB-2 (70 amp) Trips at	87.5 amps	
b. Compressor Motor	Full Load Amps (FLA)	17.6 amps @ 460 VAC (with current limiting set at 21 amps)	
c. Condenser Fan Motor		380 VAC, Single Phase, 50 Hz	460 VAC, Single Phase, 60 hz
	Full Load Amps	1.3 amps	1.6 amps
	Horsepower	0.43 hp	0.75 hp
	Rotations Per Minute	1425 rpm	1725 rpm
	Voltage and Frequency	360 - 460 VAC +/- 2.5 hz	400 - 500 VAC +/- 2.5 hz
	Bearing Lubrication	Factory lubricated, additional grease not required.	
	Rotation	Counter-clockwise when viewed from shaft end.	
d. Evaporator Coil Heaters	Number of Heaters	6	
	Rating	750 watts +5/ -10% each @ 230 VAC	
	Resistance (cold)	66.8 to 77.2 ohms @ 20°C (68°F)	
	Type	Sheath	
e. Evaporator Fan Motor(s)		380 VAC/50 hz	460 VAC/60 hz
	Full Load Amps High Speed	1.6	2.1
	Full Load Amps Low Speed	0.6	0.6
	Nominal Horsepower High Speed	0.58	1.0
	Nominal Horsepower Low Speed	0.07	0.12
	Rotations Per Minute High Speed	2850 rpm	3450 rpm
	Rotations Per Minute Low Speed	1425 rpm	1750 rpm
	Voltage and Frequency	360 - 460 VAC +/- 1.25 hz	400 - 500 VAC +/- 1.5 hz
	Voltage & Frequency using power autotransformer	180 - 230 VAC +/- 1.25hz	200 - 250 VAC +/- 1.5 hz
	Bearing Lubrication	Factory lubricated, additional grease not required	
	Rotation EF#1	CW when viewed from shaft end	
	Rotation EF#2	CCW when viewed from shaft end	
	f. Fuses	Control Circuit	7.5 amps (F3A, F3B)
Controller/DataCORDER		5 amps (F1 & F2)	
Emergency Defrost		5 amps (FED)	
Drain Line Heater		5 amps (FDH)	
Humidity Power Transformer		5 amps (FH)	
g. Compressor Crankcase Heater	180 watts @ 460 VAC		

2.3 ELECTRICAL DATA (Continued)

h. Humidity Sensor	Orange wire	Power
	Red wire	Output
	Brown wire	Ground
	Input voltage	5 vdc
	Output voltage	0 to 3.3 vdc
	Output voltage readings verses relative humidity (RH) percentage:	
	30%	0.99 V
	50%	1.65 V
	70%	2.31 V
	90%	2.97 V
i. Controller	Setpoint Range	-30 to +30°C (-22 to +86°F)

2.4 SAFETY AND PROTECTIVE DEVICES

Unit components are protected from damage by safety and protective devices listed in the following table. These devices monitor the unit operating conditions and open a set of electrical contacts when an unsafe condition occurs.

Table 2-1 Safety and Protective Devices

UNSAFE CONDITION	SAFETY DEVICE	DEVICE SETTING
Excessive current draw	Circuit Breaker (CB-1) - Manual Reset	Trips at 29 amps (460 VAC)
	Circuit Breaker (CB-2, 50 amp) -Manual Reset	Trips at 62.5 amps (230 VAC)
	Circuit Breaker (CB-2, 70 amp) -Manual Reset	Trips at 87.5 amps (230 VAC)
Excessive current draw in the control circuit	Fuse (F3A & F3B)	7.5 amp rating
Excessive current draw by the controller	Fuse (F1 & F2)	5 amp rating
Excessive current draw by the emergency defrost circuit	Fuse (FED)	5 amp rating
Excessive condenser fan motor winding temperature	Internal Protector (IP-CM) - Automatic Reset	N/A
Excessive compressor motor winding temperature	Internal Protector (IP-CP) - Automatic Reset	N/A
Excessive evaporator fan motor(s) winding temperature	Internal Protector(s) (IP-EM) - Automatic Reset	N/A
Abnormal pressures / temperatures in the high refrigerant side	Fusible Plug - Used on the Receiver	99°C = (210°F)
	Rupture Disc - Used on the Water-Cooled Condenser	35 kg/cm ² = (500 psig)
Abnormally high discharge pressure	High Pressure Switch (HPS)	Opens at 25 kg/cm ² (350 psig)

2.5 REFRIGERATION CIRCUIT

Starting at the compressor (see Figure 2-7, upper schematic), the suction gas is compressed to a higher pressure and temperature.

The gas flows through the discharge service valve into the pressure regulating valve. During periods of low ambient operation, the discharge pressure regulating valve modulates the flow of refrigerant to maintain a pre-set minimum discharge pressure. Refrigerant gas then moves into the air-cooled condenser. When operating with the air-cooled condenser active, air flowing across the coil fins and tubes cools the gas to saturation temperature. By removing latent heat, the gas condenses to a high pressure/high temperature liquid and flows to the receiver, which stores the additional charge necessary for low temperature operation.

When operating with the water-cooled condenser active (see Figure 2-7, lower schematic), the refrigerant gas passes through the air-cooled condenser and enters the water-cooled condenser shell. The water flowing inside the tubing cools the gas to saturation temperature in the same manner as the air passing over the air-cooled condenser. The refrigerant condenses on the outside of the tubes and exits as a high temperature liquid. The water-cooled condenser also acts as a receiver, storing excess refrigerant.

The liquid refrigerant continues through the liquid line service valve, the filter-drier (which keeps refrigerant clean and dry), and a heat exchanger (that increases subcooling of the liquid) to the thermostatic expansion valve (TXV). As the liquid refrigerant passes through the variable orifice of the expansion valve, some of it vaporizes into a gas (flash gas). Heat is absorbed from the return air by the balance of the liquid, causing it to vaporize in the evaporator coil. The vapor then flows through the suction modulating valve to the compressor.

The thermostatic expansion valve is activated by the bulb strapped to the suction line near the evaporator

outlet. The valve maintains a constant superheat at the coil outlet regardless of load conditions.

During periods of low load, the suction modulating valve decreases flow of refrigerant to the compressor. This action balances the compressor capacity with the load and prevents operation with low coil temperatures. In this mode of operation, the quench valve will open as required to provide sufficient liquid refrigerant flow into the suction line for cooling of the compressor motor. The quench valve senses refrigerant condition entering the compressor and modulates the flow to prevent entrance of liquid into the compressor.

The refrigeration system is also fitted with a condenser pressure transducer, which feeds information to the controller. When operating on the air-cooled condenser, the controller programming will operate the condenser fan so as to attempt to maintain discharge pressures above 130psig in low ambients. At ambients below 27°C (80°F), the condenser fan will cycle on and off depending on condenser pressure and operating times.

- 1 The condenser fan will start if the condenser pressure is greater than 200psig OR the condenser fan has been OFF for more than 60 seconds.
- 2 The condenser fan will stop if the condenser pressure is less than 130psig AND the condenser fan has been running for at least 30 seconds.

At ambients above 27°C (80°F), condenser pressure control is disabled and the condenser fan runs continuously.

On systems fitted with a water pressure switch, the condenser fan will be off when there is sufficient pressure to open the switch. If water pressure drops below the switch cut out setting, the condenser fan will be automatically started. When operating a system fitted with a condenser fan switch, the condenser fan will be off when the switch is placed in the "O" position. The condenser fan will be on when the switch is placed in the "I" position.

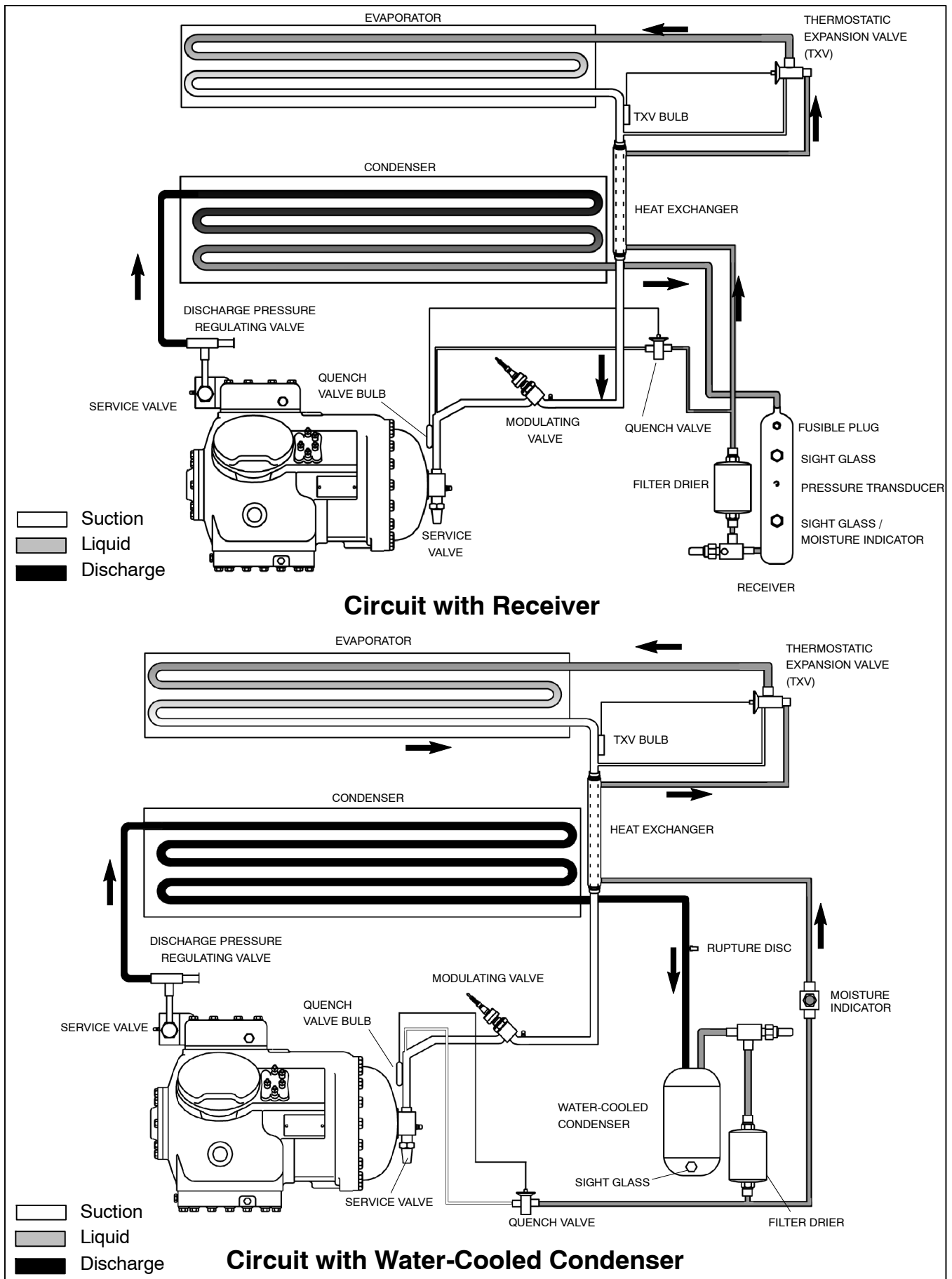
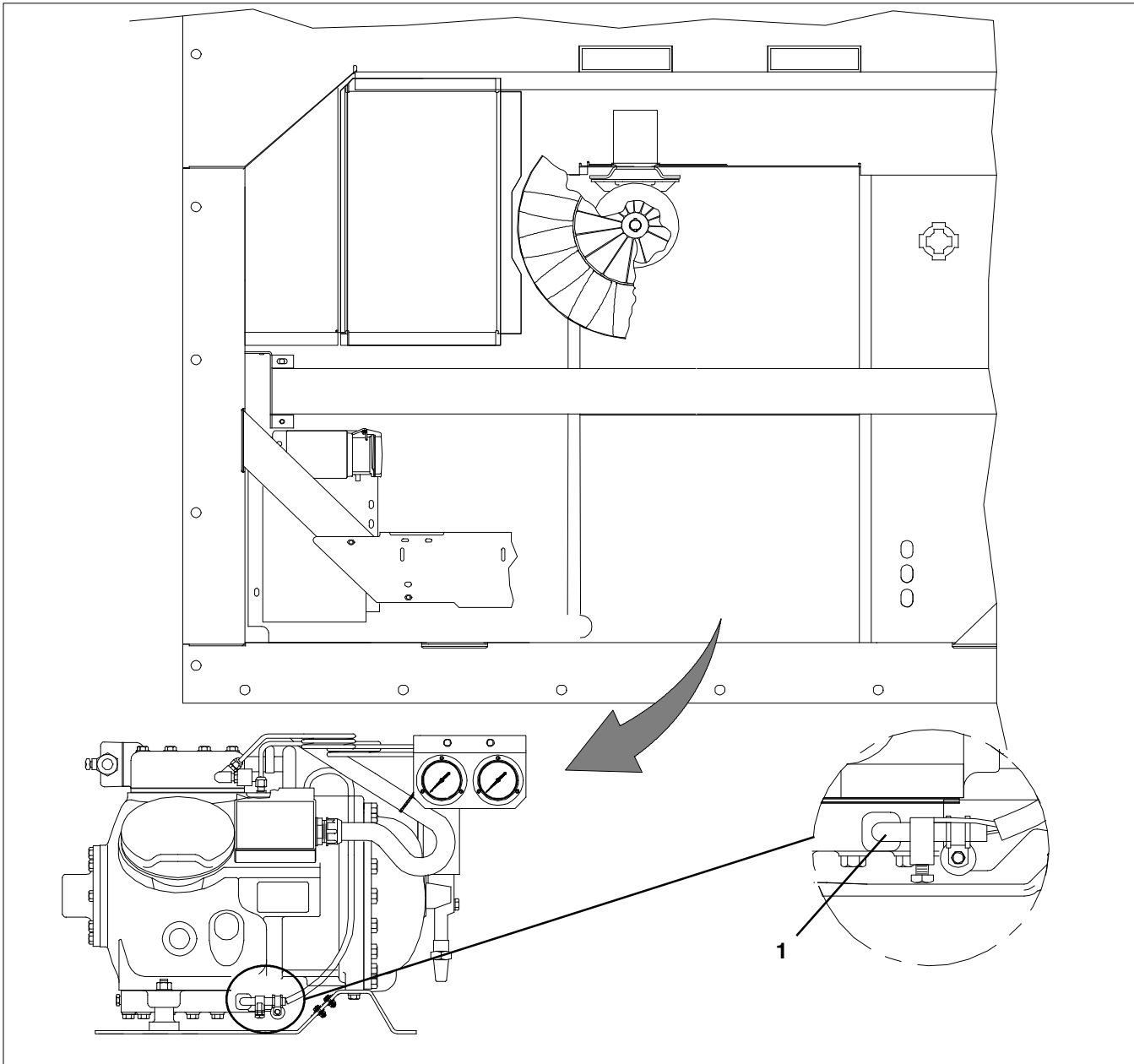

Figure 2-7 Refrigeration Circuit Schematic

2.6 ARCTIC OPTION

The arctic option consists of the crankcase heater (CCH) installed onto the compressor, which warms the

refrigerant oil and evaporates any liquid refrigerant which may have migrated to the compressor crankcase.



1. Compressor Crankcase Heater (CCH)

Figure 2-8 Arctic Option

SECTION 3
MICROPROCESSOR

3.1 TEMPERATURE CONTROL MICROPROCESSOR SYSTEM

The temperature control Micro-Link 3 microprocessor system (see Figure 3-6) consists of a keypad, display module, control module (controller), and interconnecting wiring. The controller houses the temperature control software and the DataCORDER Software. The temperature control software functions to operate the unit components as required to provide the desired cargo temperature and humidity. The DataCORDER software functions to record unit

operating parameters and cargo temperature parameters for future retrieval. Coverage of the temperature control software begins with paragraph 3.2. Coverage of the DataCORDER software is provided in paragraph 3.6.

The keypad and display module serve to provide user access and readouts for both of the controller functions, temperature control, and DataCORDER. The functions are accessed by keypad selections and viewed on the display module. The components are designed to permit ease of installation and removal.

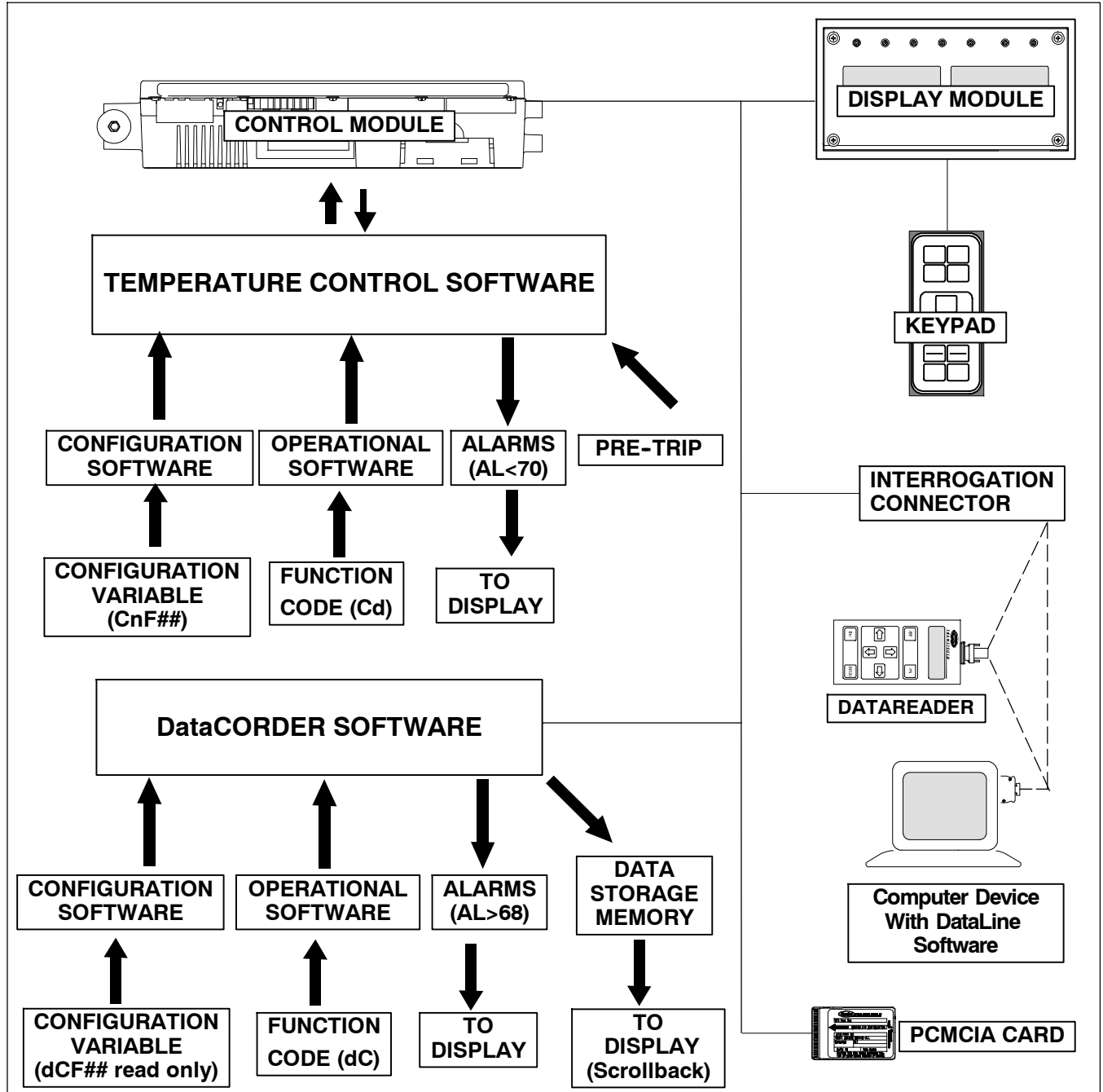

Figure 3-6 Temperature Control System

3.1.1 Keypad

The keypad (Figure 3-7) is mounted on the right-hand side of the control box. The keypad consists of 11 push button switches that act as the user's interface with the controller. Descriptions of the switch functions are provided in Table 3-1.

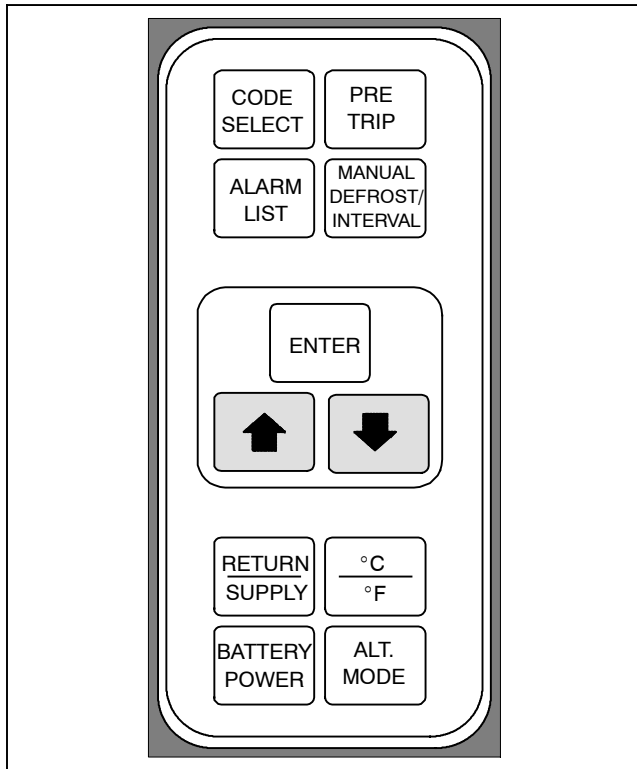

Figure 3-7 Keypad

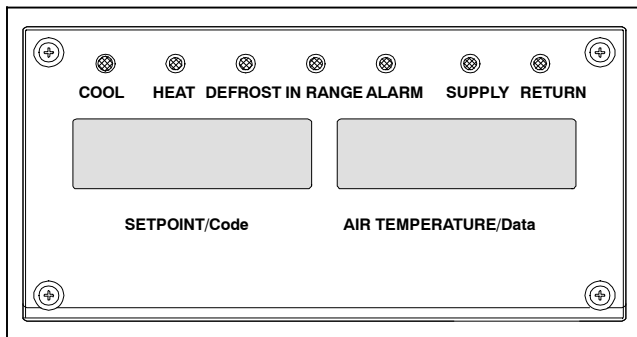

Figure 3-8 Display Module

3.1.2 Display Module

The display module (Figure 3-8) consists of two 5-digit displays and seven indicator lights. The indicator lights include:

1. Cool - White LED: Energized when the refrigerant compressor is energized.
2. Heat - Orange LED: Energized to indicate heater operation in the heat or defrost mode.
3. Defrost - Orange LED: Energized when the unit is in the defrost mode.
4. In-Range - Green LED: Energized when the controlled temperature probe is within specified tolerance of set point.

Table 3-1 Keypad Function

KEY	FUNCTION
Code Select	Accesses function codes.
Pre-Trip	Displays the pre-trip selection menu. Discontinues pre-trip in progress.
Alarm List	Displays alarm list and clears the alarm queue.
Manual Defrost/Interval	Displays selected defrost mode. Depressing and holding the Defrost interval key for five seconds will initiate defrost using the same logic as if the optional manual defrost switch was toggled on.
Enter	Confirms a selection or saves a selection to the controller
Arrow Up	Change or scroll a selection upward. Pre-trip advance or test interruption.
Arrow Down	Change or scroll a selection downward. Pre-trip repeat backward
Return/Supply	Displays non-controlling probe temperature (momentary display).
Degrees C/ Degrees F	Displays alternate English/Metric scale (momentary display). When set to degrees Fahrenheit, pressure is displayed in psig and vacuum in "/>hg. "P" appears after the value to indicate psig and "i" appears for inches of mercury. When set to degrees Celsius, pressure readings are in bars. "b" appears after the value to indicate bars.
Battery Power	Initiate battery backup mode to allow set point and function code selection if AC power is not connected.
ALT. Mode	This key is pressed to switch the functions from the temperature software to the DataCORDER Software. The remaining keys function the same as described above except the readings or changes are made to the DataCORDER programming.

NOTE

The controlling probe in the perishable range will be the SUPPLY air probe and the controlling probe in the frozen range will be the RETURN air probe.

5. Supply - Yellow LED: Energized when the supply air probe is used for control. When this LED is illuminated, the temperature displayed in the AIR TEMPERATURE display is the reading at the supply air probe. This LED will flash if dehumidification or humidification is enabled.
6. Return - Yellow LED: Energized when the return air probe is used for control. When this LED is illuminated, the temperature displayed in the AIR TEMPERATURE display is the reading at the return air probe. This LED will flash if dehumidification or humidification is enabled.
7. Alarm - Red LED: Energized when there is an active or an inactive shutdown alarm in the alarm queue.

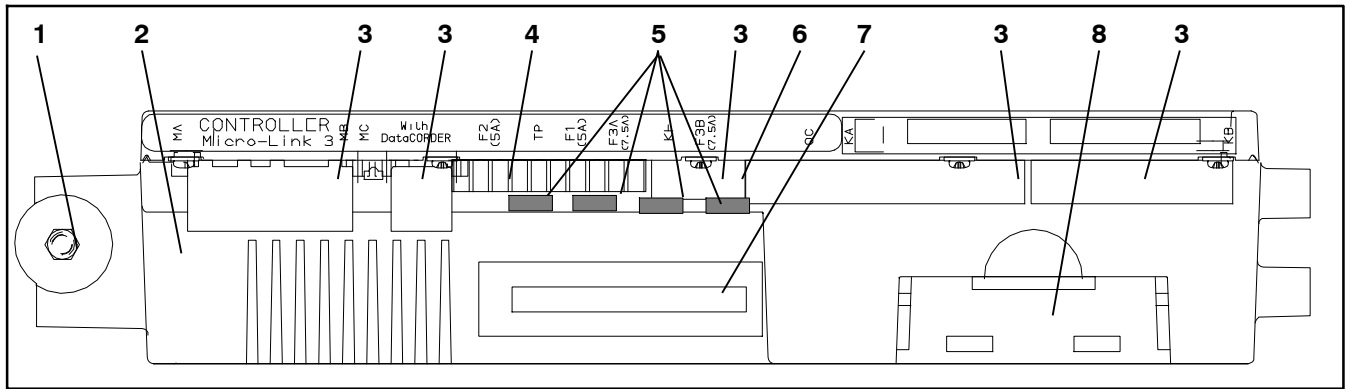

- | | |
|--|--|
| <ol style="list-style-type: none"> 1. Mounting Screw 2. Micro-Link 3 Controller 3. Connectors 4. Test Points | <ol style="list-style-type: none"> 5. Fuses 6. Control Circuit Power Connection (Location: In back of controller) 7. Software Programming Port 8. Battery Pack |
|--|--|

Figure 3-9 Micro-Link 3 Controller

3.1.3 Controller



Do not remove wire harnesses from controller unless you are grounded to the unit frame with a static safe wrist strap.



Unplug all controller wire harness connectors before performing arc welding on any part of the container.

NOTE

Do not attempt to service the controller. Breaking the seal will void the warranty.

NOTE

Do not attempt to use an ML2i PC card in an ML3 equipped unit. The PC cards are physically different and will result in damage to the controller.

The Micro-Link 3 controller is a single module microprocessor as shown in Figure 3-9. It is fitted with test points, harness connectors and a software card programming port.

3.2 CONTROLLER SOFTWARE

The controller software is a custom designed program that is subdivided into the configuration software and the operational software. The controller software performs the following functions:

- a. Control supply or return air temperature to required limits, provide modulated refrigeration control, electric heat control and defrost. Defrost is performed to clear buildup of frost and ice from the coil to ensure continuous conditioned air delivery to the load.
- b. Provide default independent readouts of set point and supply or return air temperatures.

- c. Provide ability to read, and if applicable, modify the configuration software variables, operating software function codes, and alarm code indications.
- d. Provide a pre-trip step-by-step checkout of refrigeration unit performance, including proper component operation, electronic and refrigeration control operation, heater operation, probe calibration, pressure limiting, and current limiting settings.
- e. Provide battery-powered ability to access or change selected codes and set points without AC power connected.
- f. Provide the ability to reprogram the software through the use of a memory card.

3.2.1 Configuration Software (Configuration Variables)

The configuration software is a variable listing of the components available for use by the operational software. This software is factory-installed in accordance with the equipment fitted and options listed on the original purchase order. Changes to the configuration software are required only when the original software has been lost or a physical change has been made to the unit, such as the addition or removal of an option. A configuration variable list is provided in Table 3-4 (page 3-13). A change to the factory-installed configuration software is achieved via a configuration card.

3.2.2 Operational Software (Function Codes)

The operational software is the actual operation programming of the controller, which activates or deactivates components in accordance with current unit operation conditions and operator selected modes of operation.

The programming is divided into function codes. Some of the codes are read only while the remaining codes may be user configured. The value of the user configurable codes can be assigned in accordance with user desired mode of operation. A list of the function codes is provided in Table 3-5 (page 3-14)

To access the function codes, perform the following:

- a. Press the CODE SELECT key, then press an arrow key until the left window displays the desired code number.
- b. The right window will display the value of this item for five seconds before returning to the normal display mode.
- c. If a longer time is desired, press the ENTER key to extend the time to 30 seconds.

3.3 MODES OF OPERATION

The operational software responds to various inputs. These inputs come from the temperature and pressure sensors, the temperature set point, the settings of the the configuration variables, and the function code assignments. The action taken by the operational software will change if any one of the inputs changes. Overall interaction of the inputs is described as a “mode” of operation. The modes of operation include perishable (chill) mode and frozen mode. Descriptions of the controller interaction and modes of operation are provided in the following sub paragraphs.

3.3.1 Temperature Control - Perishable Mode

With configuration variable CnF26 (Heat Lockout Temperature) set to -10°C , the perishable mode of operation is active with set points *above* -10°C ($+14^{\circ}\text{F}$). With the variable set to -5°C , the perishable mode is active *above* -5°C ($+23^{\circ}\text{F}$). Refer to Table 3-4, page 3-13.

When in the perishable mode, the controller maintains the supply air temperature at set point, the SUPPLY indicator light will be illuminated on the display module, and the default reading on the display window will be the supply temperature sensor reading.

When the supply air temperature enters the in-range temperature tolerance (as selected at function code Cd30), the in-range light will energize.

3.3.2 Evaporator Fan Operation

Opening of an evaporator fan internal protector will shut down a unit with Normal Evaporator Fan Operation. (CnF32 set to 2EFO). On units equipped with Single Evaporator Fan Capability (CnF32 set to 1EFO), additional relays are installed to allow the unit to continue to operate on a single fan (refer to Table 3-4, page 3-13).

3.3.3 Defrost Interval

Controller function code Cd27 sets two modes for defrost initiation – either user-selected timed intervals or automatic control. The user-selected values are 3, 6, 9, 12, or 24 hours and the factory default for the timed interval is 12 hours (some units may be configured to allow defrost to be disabled altogether; in this case a user-selected value of OFF will be available). Refer to Table 3-5.

In perishable mode, perishable-pulldown mode, or frozen-pulldown mode, automatic defrost starts with an initial defrost set to three hours and then adjusts the interval to the next defrost based on the accumulation of ice on the evaporator coil. In this way, defrosts are scheduled to occur only when necessary.

Once setpoint has been reached in frozen operation, the automatic selection will set the time interval to 12 hours for the first two defrosts once the return probe is reading

below the frozen setpoint and then adjust to 24 hours thereafter.

All defrost interval times reflect the number of compressor runtime hours since the last defrost de-ice cycle. The minimum defrost interval under the automatic setting is three hours, while the maximum is 24. In frozen mode, the amount of wall-clock time necessary to accumulate a given amount of defrost interval time will exceed the defrost interval time by a factor of two to three depending on the compressor duty-cycle. Defrost interval time is not accumulated in any mode until the defrost termination sensor reads less than 10°C (50°F).

3.3.4 Failure Action

Function code Cd29 may be operator set to allow continued operation in the event the control sensors are reading out of range. The factory default is full system shutdown (refer to Table 3-5, page 3-14).

3.3.5 Generator Protection

Function codes Cd31 and Cd32 may be operator set to control start-up sequence of multiple units and operating current draw. The factory default allows on demand starting of units and full current draw (refer to Table 3-5, page 3-14).

3.3.6 Condenser Pressure Control

When configuration variable CnF14 is set to “In,” the condenser pressure control logic is activated to maintain discharge pressures above 130 psig in low temperature ambients. The logic turns the condenser fan on or off in accordance with the condenser pressure transducer reading (refer to Table 3-4, page 3-13.) The function is enabled when the following conditions are met:

1. The ambient sensor reading is less than or equal to 27°C (80°F), and
2. Voltage/Frequency ratio is less than or equal to 8.38.

When the above conditions are met, either pressures or timers may dictate a change of state from OFF to ON or ON to OFF. If the condenser fan is OFF, it will be energized if saturated condensing pressure is greater than 200psig OR if the condenser fan has been OFF for a variable time period of up to 60 seconds depending on the ambient temperature. As the ambient temperature increases, the amount of time that the condenser fan is energized will correspondingly increase towards the maximum.

If the condenser fan is ON, it will de-energize only if the saturated condensing pressure is less than 130psig and the condenser fan has been running for a minimum of thirty seconds depending on the ambient temperature.

3.3.7 Arctic Mode

With arctic mode enabled (configuration variable CnF29 set to “In”), there will be a 30-minute time delay at startup if the ambient is colder than -10.0°C (14°F). When the START/STOP switch is placed in the “I” (ON) position, the controller will energize the compressor crankcase heater. Operation of the heater will warm the oil and boil off any liquid refrigerant that may be present in the crankcase.

If Pre-Trip is initiated during the 30 minute time period, Pre-Trip will be allowed to run normally. Once Pre-Trip is over, the controller will revert to its normal control mode logic (refer to Table 3-4, page 3-13).

3.3.8 Perishable Mode - Conventional

The unit is capable of maintaining supply air temperature to within $\pm 0.25^{\circ}\text{C}$ ($\pm 0.5^{\circ}\text{F}$) of set point. Supply air temperature is controlled by positioning of the suction modulation valve (SMV), cycling of the compressor, and cycling of the heaters.

When pulling down from a temperature that is more than 5°C (9°F) above set point, the SMV will open to reduce the pulldown time. However, pressure and current limit functions may restrict the valve if either exceeds the preset value.

The operational software is designed so the SMV will begin to close as the set point is reached. The SMV will continue to close and restrict refrigerant flow until the capacity of the unit and the load are balanced.

If the temperature drops below the set point, the compressor will remain running for a few minutes. This is to accommodate any initial undershoot which might occur. After this time has expired and the temperature is 0.2°C (0.4°F) or greater below the set point, the compressor will be turned OFF.

If the temperature drops to 0.5°C (0.9°F) below set point, the heaters will be energized. The heaters will de-energize when the temperature rises to 0.2°C (0.4°F) below the set point. The compressor will not restart until the temperature rises to 0.2°C (0.4°F) above the set point and three minutes have elapsed since the last compressor turn off.

3.3.9 Perishable Mode - Economy

The economy mode is an extension of the conventional mode and is applicable to units with two speed evaporator fan motors. The mode is activated when the setting of function code Cd34 is "ON." Economy mode is provided for power saving purposes. Economy mode could be utilized in the transportation of temperature tolerant cargo or non-respiration items that do not require high airflow for removing respiration heat. There is no active display indicator that economy mode has been activated. To check for economy mode, perform a manual display of code Cd34.

In order to achieve economy mode, a perishable set point must be selected prior to activation. When economy mode is active, the evaporator fans will be controlled as follows:

At the start of each cooling or heating cycle, the evaporator fans will be run in high speed for three minutes. They will then be switched to low speed any time the supply air temperature is within $\pm 0.25^{\circ}\text{C}$ (0.45°F) of the set point and the return air temperature is less than or equal to the supply air temperature $+3^{\circ}\text{C}$ (5.4°F). The fans will continue to run in low speed for one hour. At the end of the hour, the evaporator fans will switch back to high speed and the cycle will be repeated.

3.3.10 Perishable Mode - Dehumidification

The dehumidification mode is provided to reduce the humidity levels inside the container. The mode is activated when a humidity value is set at at function code Cd33. The display module SUPPLY LED will flash ON and OFF every second to indicate that the dehumidification mode is active. Once the mode is active and the following conditions are satisfied, the controller will activate the heat relay to begin dehumidification.

1. The humidity sensor reading is above the set point.
2. The supply air temperature is less than 0.25°C above set point.
3. The heater debounce timer (three minutes) has timed out.
4. Heater termination thermostat (HTT) is closed.

If the above conditions remain true for at least one hour, the evaporator fans will switch from high to low speed operation. The evaporator fan speed will switch every hour thereafter as long as all conditions are met (see Bulb Mode section for different evaporator fan speed options). If any condition except for item (1) becomes false OR if the relative humidity sensed is 2% below the dehumidification set point, the high speed evaporator fans will be energized.

In the dehumidification mode, power is applied to the defrost and drain pan heaters. This added heat load causes the controller to open the suction modulating valve to match the increased heat load while still holding the supply air temperature very close to the set point.

Opening the modulating valve reduces the temperature of the evaporator coil surface, which increases the rate at which water is condensed from the passing air. Removing water from the air reduces the relative humidity. When the relative humidity sensed is 2% below the set point, the controller de-energizes the heat relay. The controller will continue to cycle heating to maintain relative humidity below the selected set point. If the mode is terminated by a condition other than the humidity sensor, e.g., an out-of-range or compressor shutdown condition, the heat relay is de-energized immediately.

Two timers are activated in the dehumidification mode to prevent rapid cycling and consequent contactor wear. They are:

- Heater debounce timer (three minutes)
- Out-of-range timer (five minutes)

The heater debounce timer is started whenever the heater contactor status is changed. The heat contactor remains energized (or de-energized) for at least three minutes even if the set point criteria is satisfied.

The out-of-range timer is started to maintain heater operation during a temporary out-of-range condition. If the supply air temperature remains outside of the user selected in-range setting for more than five minutes, the heaters will be de-energized to allow the system to recover. The out-of-range timer starts as soon as the temperature exceeds the in-range tolerance value set by function code Cd30.

3.3.11 Perishable, Dehumidification - Bulb Mode

Bulb mode is an extension of the dehumidification mode, which allows changes to the evaporator fan speed and/or defrost termination set points.

Bulb mode is active when function code Cd35 is set to "Bulb." Once the bulb mode is activated, the user may then change the dehumidification mode evaporator fan operation from the default (speed alternates from low to high each hour) to constant low or constant high speed. This is done by toggling function code Cd36 from its default of "alt" to "Lo" or "Hi" as desired. If low speed evaporator fan operation is selected, the user has the additional capability of selecting dehumidification set points from 60 to 95% (instead of the normal 65 to 95%).

In addition, if bulb mode is active, function code Cd37 may be set to override the previous defrost termination thermostat settings (refer to paragraph 4.10.4) The temperature at which the defrost termination thermostat will be considered “open” may be changed [in 0.1°C (0.2°F) increments] to any value between 25.6°C (78°F) and 4°C (39.2°F). The temperature at which the defrost termination thermostat is considered closed for interval timer start or demand defrost is 10°C (50°F) for “open” values from 25.6°C down to a 10°C setting. For “open” values lower than 10°C, the “closed” values will decrease to the same value as the “open” setting.

Bulb mode is terminated when:

1. Bulb mode code Cd35 is set to “Nor.”
2. Dehumidification code Cd33 is set to “Off.”
3. The user changes the set point to one that is in the frozen range.

When bulb mode is disabled by any of the above, the evaporator fan operation for dehumidification reverts to “alt” and the DTS termination setting resets to the value determined by controller configuration variable CnF41.

3.3.12 Temperature Control - Frozen Mode

With configuration variable CnF26 set to -10°C, the frozen mode of operation is active with set points *at or below* -10°C (+14°F). With the variable set to -5°C, the frozen mode is active at or below -5°C (+23°F).

When in the frozen mode, the controller maintains the return air temperature at set point, the RETURN indicator light will be illuminated on the display module, and the default reading on the display window will be the return air probe reading.

When the return air temperature enters the in-range temperature tolerance as selected at function code Cd30, the in-range light will energize.

3.3.13 Frozen Mode - Conventional

Frozen range cargoes are not sensitive to minor temperature changes. The method of temperature control employed in this range takes advantage of this fact to greatly improve the energy efficiency of the unit. Temperature control in the frozen range is accomplished by cycling the compressor on and off as the load demand requires. The unit will operate in the conventional frozen mode when the controller set point is at or below the frozen range and function code CD34 is set to “OFF.”

If the return air temperature in the container drops 0.2°C (0.4°F) below the set point, the compressor is cycled off. When the temperature is greater than 0.2°C (0.4°F) above the set point and the three minute time delay has been met, the compressor will restart. The unit will always operate at full capacity and the suction modulation valve will open as allowed by current and pressure limiting.

NOTE

On start up of the unit, SMV will reset to a known open position. This is accomplished by assuming the valve was fully open, driving it fully closed, resetting the percentage open to zero, then opening to a known 21% staging position.

To prevent rapid cycling of the compressor, a three minute compressor off time must be satisfied before the

compressor will restart. Under a condition of rapidly changing return air temperature, the time delay may allow the return air temperature to rise slightly above set point temperature before the compressor can restart.

3.3.14 Frozen Mode - Economy

In order to activate economy frozen mode operation, a frozen set point temperature must be selected. The economy mode is active when function code Cd34 is set to “ON.” When economy mode frozen is active, the system will perform normal frozen mode operations except that the entire refrigeration system, excluding the controller, will be turned off when the control temperature is less than or equal to the set point -2°C. After an off-cycle period of 60 minutes, the unit will turn on high speed evaporator fans for three minutes and then check the control temperature. If the control temperature is greater than or equal to the set point +0.2°C, the unit will restart the refrigeration system and continue to cool until the previously mentioned off-cycle temperature criteria are met. If the control temperature is less than the set point +0.2°C, the unit will turn off the evaporator fans and restart another 60 minute off-cycle.

3.4 CONTROLLER ALARMS

Alarm display is an independent controller software function. If an operating parameter is outside of expected range or a component does not return the correct signals back to the controller, an alarm is generated. A listing of the alarms is provided in Table 3-6, page 3-18.

The alarm philosophy balances the protection of the refrigeration unit and that of the refrigerated cargo. The action taken when an error is detected always considers the survival of the cargo. Rechecks are made to confirm that an error actually exists.

Some alarms requiring compressor shutdown have time delays before and after to try to keep the compressor on line. An example is alarm code “LO,” (low main voltage), when a voltage drop of over 25% occurs, an indication is given on the display, but the unit will continue to run.

An alarm is indicated by flashing an alarm code on the display panel, and for some alarms, by the alarm light illuminating.

When an Alarm Occurs:

- a. The red alarm light will illuminate for “20 series” alarms.
- b. If a detectable problem is found to exist, its alarm code will be alternately displayed with the set point on the left display.
- c. The user should scroll through the alarm list to determine what alarms exist or have existed. Alarms must be diagnosed and corrected before the Alarm List can be cleared.

To Display Alarm Codes:

- a. While in the Default Display mode, press the ALARM LIST key. This accesses the Alarm List Display Mode, which displays any alarms archived in the Alarm Queue.
- b. The alarm queue stores up to 16 alarms in the sequence in which they occurred. The user may scroll through the list by depressing an ARROW key.
- c. The left display will show "AL##," where ## is the alarm number sequentially in the queue.
- d. The right display will show the actual alarm code. "AA##" will display for an active alarm, where "##" is the alarm code. Or "IA##" will display for an inactive alarm (refer to Table 3-6, page 3-18).
- e. "END" is displayed to indicate the end of the alarm list if any alarms are active.
- f. "CLEAR" is displayed if all alarms are inactive. The alarm queue may then be cleared by pressing the ENTER key. The alarm list will clear and "-----" will be displayed.

NOTE

AL26 is active when all of the sensors are not responding. Check the connector at the back of the controller, if it is loose or unplugged, reconnect it. Then run a pretrip test (P5) to clear AL26.

3.5 UNIT PRE-TRIP DIAGNOSTICS

Pre-trip diagnostics is an independent controller function that will suspend normal refrigeration controller activities and provide preprogrammed test routines. The test routines include Auto Mode testing, which automatically preforms a pre programmed sequenced of tests or Manual Mode testing, which allows the operator to select and run any of the individual tests.



CAUTION

Pre-trip inspection should not be performed with critical temperature cargoes in the container.



CAUTION

When Pre-Trip key is pressed, dehumidification and bulb mode will be deactivated. At the completion of Pre-Trip activity, dehumidification and bulb mode must be reactivated.

Testing may be initiated by use of the keypad or via communication, but when initiated by communication, the controller will execute the entire battery of tests (auto mode).

At the end of a pre-trip test, the message "P," "rSLts" (pretest results) will be displayed. Pressing the ENTER key will allow the user to see the results for all subtests. The results will be displayed as "PASS" or "FAIL" for all the tests run to completion.

A detailed description of the pre-trip tests and test codes is provided in Table 3-7, page 3-22. Detailed operating instructions are provided in paragraph 4.8.

3.6 DataCORDER

3.6.1 Description

The Carrier Transicold "DataCORDER" software is integrated into the controller and serves to eliminate the temperature recorder and paper chart. The DataCORDER functions may be accessed by keypad selections and viewed on the display module. The unit is also fitted with interrogation connections (see Figure 3-6), which may be used with the Carrier Transicold Data Reader to download data. A personal computer with Carrier Transicold Data View software may also be used to download data and configure settings. The resulting file uses a proprietary file format that protects it from potential tampering or altering of data. Therefore, once downloaded, all dcx files shall be considered secured. The DataCORDER consists of:

- Configuration Software
- Operational Software
- Data Storage Memory
- Battery Low (Battery Pack)
- Real-Time Clock (with internal battery backup)
- Six thermistor inputs
- Interrogation Connections
- Power Supply (battery pack)

The DataCORDER performs the following functions:

- a. Logs data at 15, 30, 60 or 120 minute intervals and stores two years' of data (based on one hour interval).
- b. Records and displays alarms on the display module.
- c. Records results of pre-trip testing.
- d. Records DataCORDER and temperature control software generated data and events as follows:

- Container ID Change
- Software Upgrades
- Alarm Activity
- Battery Low (Battery Pack)
- Data Retrieval
- Defrost Start and End
- Dehumidification Start and End
- Power Loss (w/wo battery pack)
- Power Up (w/wo battery pack)
- Remote Probe Temperatures in the Container (USDA cold treatment and cargo probe recording)
- Return Air Temperature
- Set Point Change
- Supply Air Temperature
- Real Time Clock Battery (Internal Battery) Replacement
- Real-Time Clock Modification
- Trip Start
- ISO Trip Header (When entered via Interrogation program)
- Economy Mode Start and End
- "Auto 2" Pre-Trip Start and End
- Bulb Mode Start
- Bulb Mode changes
- Bulb Mode End
- USDA Trip Comment
- Humidification Start and End
- USDA Probe Calibration

3.6.2 DataCORDER Software

The DataCORDER Software is subdivided into the configuration software, operational software and the Data Memory.

a. Operational Software

The operational software reads and interprets inputs for use by the configuration software. The inputs are labeled Function Codes. There are 35 functions (see Table 3-8, page 3-26), which the operator may access to examine the current input data or stored data. To access these codes, do the following:

1. Press the ALT. MODE & CODE SELECT keys.
2. Press an arrow key until the left window displays the desired code number. The right window will display the value of this item for five seconds before returning to the normal display mode.
3. If a longer time is desired, press the ENTER key to extend the time to 30 seconds.

b. Configuration Software

The configuration software controls the recording and alarm functions of the DataCORDER. Reprogramming to the factory-installed configuration is achieved via the same configuration card as the unit control module software. Changes to the software may be made using the Data View integration device. A listing of the configuration variables is provided in Table 3-2. Descriptions of DataCORDER operation for each variable setting are provided in the following paragraphs.

3.6.3 Sensor Configuration (dCF02)

Two modes of operation may be configured, the Standard Mode and the Generic Mode.

a. Standard Mode

In the standard mode, the user may configure the DataCORDER to record data using one of seven standard configurations. The seven standard configuration variables, with their descriptions, are listed in Table 3-3.

The six thermistor inputs (supply, return, USDA #1, #2, #3, and cargo probe) and the humidity sensor input will be generated by the DataCORDER. An example of a report using a standard configuration is shown in Figure 3-10.

NOTE

The DataCORDER software uses the supply and return recorder sensors. The temperature control software uses the supply and return temperature sensors.

b. Generic Mode

The generic recording mode allows user selection of the network data points to be recorded. The user may select up to a total of eight data points for recording. A list of the data points available for recording follows. Changing the configuration to generic and selecting which data points to record may be done using the Carrier Transicold Data Retrieval Program.

1. Control mode
2. Control temperature
3. Frequency
4. Humidity
5. Phase A current
6. Phase B current
7. Phase C current
8. Main voltage
9. Suction modulation valve percentage
10. Discrete outputs (See Note)
11. Discrete inputs (See Note)
12. Ambient sensor
13. Compressor suction sensor
14. Compressor discharge sensor
15. Return temperature sensor
16. Supply temperature sensor
17. Defrost temperature sensor
18. Discharge pressure transducer
19. Suction pressure transducer
20. Condenser pressure transducer

Note: Bitmapped - require special handling if used

Table 3-2 DataCORDER Configuration Variables

CONFIGURATION NO.	TITLE	DEFAULT	OPTION
dCF01	(Future Use)	--	--
dCF02	Sensor Configuration	2	2,5,6,9,54,64,94
dCF03	Logging Interval (Minutes)	60	15,30,60,120
dCF04	Thermistor Format	Short	Low, Normal
dCF05	Thermistor Sampling Type	A	A,b,C
dCF06	Controlled Atmosphere/Humidity Sampling Type	A	A,b
dCF07	Alarm Configuration USDA Sensor 1	A	Auto, On, Off
dCF08	Alarm Configuration USDA Sensor 2	A	Auto, On, Off
dCF09	Alarm Configuration USDA Sensor 3	A	Auto, On, Off
dCF10	Alarm Configuration Cargo Sensor	A	Auto, On, Off

Table 3-3 DataCORDER Standard Configurations

Standard Config.	Description
2 sensors (dCF02=2)	2 thermistor inputs (supply & return)
5 sensors (dCF02=5)	2 thermistor inputs (supply & return) 3 USDA thermistor inputs
6 sensors (dCF02=6)	2 thermistor inputs (supply & return) 3 USDA thermistor inputs 1 humidity input
9 sensors (dCF02=9)	Not Applicable
6 sensors (dCF02=54)	2 thermistor inputs (supply & return) 3 USDA thermistor inputs 1 cargo probe (thermistor input)
7 sensors (dCF02=64)	2 thermistor inputs (supply & return) 3 USDA thermistor inputs 1 humidity input 1 cargo probe (thermistor input)
10 sensors (dCF02=94)	2 thermistor inputs (supply & return) 3 USDA thermistor inputs 1 humidity input 1 cargo probe (thermistor input) 3 CA inputs (NOT APPLICABLE)

3.6.4 Logging Interval (dCF03)

The user may configure four time intervals between data recordings. Data is logged at exact intervals in accordance with the real-time clock. The clock is factory set at Greenwich Mean Time.

3.6.5 Thermistor Format (dCF04)

The user may configure the format in which the thermistor readings are recorded. The low resolution is a 1 byte format and the normal resolution is a 2 byte format. The low resolution requires less memory and records temperature in 0.25°C (0.45°F) increments when in perishable mode or 0.5°C (0.9°F) increments when in the frozen mode. The normal resolution records temperature in 0.01°C (0.02°F) increments for the entire range.

3.6.6 Sampling Type (dCF05 & dCF06)

Three types of data sampling are available -average, snapshot, and USDA. When configured to average, the average of readings taken every minute over the recording period is recorded. When configured to snapshot, the sensor reading at the log interval time is recorded. When USDA is configured, the supply and return temperature readings are averaged and the three USDA probe readings are snapshot.

3.6.7 Alarm Configuration (dCF07 - dCF10)

The USDA and cargo probe alarms may be configured to OFF, ON or AUTO.

If a probe alarm is configured to OFF, then the alarm for this probe is always disabled.

If a probe alarm is configured to ON, then the associated alarm is always enabled.

If the probes are configured to AUTO, they act as a group. This function is designed to assist users who keep their DataCORDER configured for USDA recording, but do not install the probes for every trip. If all the probes are disconnected, no alarms are activated. As soon as one of the probes is installed, then all of the alarms are enabled and the remaining probes that are not installed will give active alarm indications.

The DataCORDER will record the initiation of a pre-trip test (refer to paragraph 3.5) and the results of each of the tests included in pre-trip. The data is time-stamped and may be extracted via the Data Retrieval program. Refer to Table 3-9, page 3-27 for a description of the data stored in the DataCORDER for each corresponding pre-trip test.

3.6.8 DataCORDER Power-Up

The DataCORDER may be powered up in any one of four ways:

1. *Normal AC power:* The DataCORDER is powered up when the unit is turned on via the stop-start switch.
2. *Controller DC battery pack power:* If a battery pack is installed, the DataCORDER will power up for communication when an interrogation cable is plugged into an interrogation receptacle.
3. *External DC battery pack power:* A 12-volt battery pack may also be plugged into the back of the interrogation cable, which is then plugged into an interrogation port. No controller battery pack is required with this method.
4. *Real-time Clock demand:* If the DataCORDER is equipped with a charged battery pack and AC power is not present, the DataCORDER will power up when the real-time clock indicates that a data recording should take place. When the DataCORDER is finished recording, it will power down.

During DataCORDER power-up, while using battery-pack power, the controller will perform a hardware voltage check on the battery. If the hardware check passes, the Controller will energize and perform a software battery voltage check before DataCORDER logging. If either test fails, the real-time clock battery power-up will be disabled until the next AC power cycle. Further DataCORDER temperature logging will be prohibited until that time.

An alarm will be generated when the battery voltage transitions from good to bad indicating that the battery pack needs recharging. If the alarm condition persists for more than 24 hours on continuous AC power, the battery pack needs replacement.

3.6.9 Pre-Trip Data Recording

The DataCORDER will record the initiation of a pre-trip test (refer to paragraph 3.5) and the results of each of the tests included in pre-trip. The data is time-stamped and may be extracted via the Data Retrieval program. Refer to Table 3-9 for a description of the data stored in the DataCORDER for each corresponding pre-trip test.

3.6.10 DataCORDER Communications

Data retrieval from the DataCORDER can be accomplished by using one of the following; DataReader, DataLine/DataView or a communications interface module.

NOTE

A DataReader, DataLine/DataView, or a communications interface module display of Communication Failed is caused by faulty data transfer between the datacorder and the data retrieval device. Common causes include:

1. Bad cable or connection between DataCORDER and data retrieval device.
2. PC communication port(s) unavailable or misassigned.
3. Chart Recorder Fuse (FCR) blown.

Communication identification for the models covered herein may be obtained on the Container Products Group Information Center by authorized Carrier Transicold Service Centers.

a. DataReader

The Carrier Transicold Data Reader (see Figure 3-11) is a simple to operate hand held device designed to extract data from the DataCORDER and then upload it to a personal computer. The Data Reader has the ability to store multiple data files. Refer to Data Retrieval manual 62-10629 for a more detailed explanation of the DataReader.

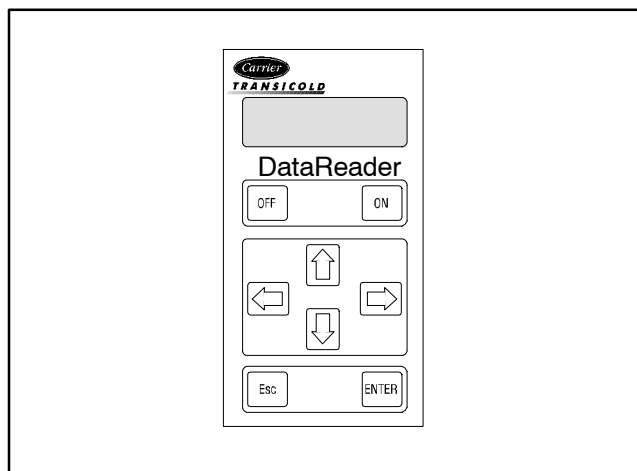

Figure 3-11 Data Reader

b. DataBANK™ Card

The DataBANK™ card is a PCMCIA card that interfaces with the controller through the programming slot and can download data at a much faster rate when compared to the PC or DataReader. Files downloaded to the DataBANK card files are accessible through an Omni PC Card Drive. The files can then be viewed using the DataLine software.

c. DataLine

The DataLINE software for a personal computer is supplied on both floppy disks and CD. This software allows interrogation, configuration variable assignment, screen view of the data, hard copy report generation, cold treatment probe calibration, and file management. Refer to Data Retrieval manual 62-10629 for a more detailed explanation of the DataLINE interrogation software. The DataLine manual may be found on the Internet at www.container.carrier.com.

d. Communications Interface Module

The communications interface module is a slave module which allows communication with a master central monitoring station. The module will respond to communication and return information over the main power line. With a remote monitoring unit installed, all functions and selectable features that are accessible at the unit may be performed at the master station. Retrieval of all DataCORDER reports may also be performed. Refer to the master system technical manual for further information.

3.6.11 USDA Cold Treatment

Sustained cold temperature has been employed as an effective postharvest method for the control of Mediterranean and certain other tropical fruit flies. Exposing infested fruit to temperatures of 2.2°C (36°F) or below for specific periods results in the mortality of the various stages of this group of insects.

In response to the demand to replace fumigation with this environmentally sound process, Carrier has integrated Cold Treatment capability into its microprocessor system. These units have the ability to maintain supply air temperature within one-quarter degree Celsius of setpoint and record minute changes in product temperature within the DataCORDER memory, thus meeting USDA criteria. Information on USDA is provided in the following subparagraphs

a. USDA Recording

A special type of recording is used for USDA cold treatment purposes. Cold treatment recording requires three remote temperature probes be placed at prescribed locations in the cargo. Provision is made to connect these probes to the DataCORDER via receptacles located at the rear left-hand side of the unit. Four or five receptacles are provided. The four three-pin receptacles are for the probes and fifth, five-pin, receptacle is the rear connection for the the Interrogator. The probe receptacles are sized to accept plugs with tricam coupling locking devices. A label on the back panel of the unit shows which receptacle is used for each probe.

The standard DataCORDER report displays the supply and return air temperatures. The cold treatment report displays USDA #1, #2, #3, and the supply and return air temperatures. Cold treatment recording is backed up by a battery so recording can continue if AC power is lost.

b. USDA Message Trip Comment

A special feature is incorporated which allows the user to enter a USDA (or other) message at the head of a data report. The maximum message length is 78 characters. Only one message will be recorded per day.

3.6.12 USDA Cold Treatment Procedure

The following is a summary of the steps required to initiate a USDA Cold Treatment:

- a. Calibrate the three USDA probes by ice bathing the probes and performing the calibration function with the DataReader or a personal computer. This calibration procedure determines the probe offsets and stores them in the controller for use in generating the cold treatment report. Refer to the Data Retrieval manual 62-10629 for more details.
- b. Pre-cool the container to the treatment temperature or below.
- c. Install the DataCORDER module battery pack (if not already installed).
- d. Place the three probes. The probes are placed into the pulp of the fruit (at the locations defined in the following table) as the product is loaded.

Sensor 1	Place in pulp of the product located next to the return air intake.
Sensor 2	Place in pulp of the product five feet from the end of the load for 40-foot containers, or three feet from the end of the load for 20-foot containers. This probe should be placed in a center carton at one-half the height of the load.
Sensor 3	Place in pulp of product five feet from the end of the load for 40-foot containers or three feet from the end of the load for 20-foot containers. This probe should be placed in a carton at a side wall at one-half the height of the load.

- e. To initiate USDA Recording, connect the personal computer and perform the configuration as follows:
 1. Fill in ISO header information
 2. Add a trip comment if desired
 3. Configure for five probes (s, r, P1, P2, P3)
 4. Configure for one-hour logging interval
 5. Set the sensor configuration at USDA
 6. Configure for two byte memory storage format
 7. Perform a trip start

3.6.13 DataCORDER Alarms

Alarm display is an independent DataCORDER function. If an operating parameter is outside of the expected range or a component does not return the correct signals back to the DataCORDER an alarm is generated. The DataCORDER contains a buffer of up to eight alarms. A listing of the DataCORDER alarms is provided in Table 3-10, page 3-28. Refer to paragraph 3.6.7 for configuration information.

To display alarm codes:

- a. While in the Default Display mode, press the ALT. MODE & ALARM LIST keys. This accesses the DataCORDER Alarm List Display Mode, which displays any alarms stored in the Alarm Queue.
- b. To scroll to the end of the alarm list, press the UP ARROW. Depressing the DOWN ARROW key will scroll the list backward.
- c. The left display will show "AL#" where # is the alarms number in the queue. The right display will show "AA##," if the alarm is active, where ## is the alarm number. "IA##," will show if the alarm is inactive
- d. "END" is displayed to indicate the end of the alarm list if any alarms are active. "CLEAR" is displayed if all the alarms in the list are inactive.
- e. If no alarms are active, the Alarm Queue may be cleared. The exception to this rule is the DataCORDER Alarm Queue Full alarm (AL91), which does not have to be inactive in order to clear the alarm list. To clear the alarm list:
 1. Press the ALT. MODE & ALARM LIST keys.
 2. Press the UP/DOWN ARROW key until "CLEAR" is displayed.
 3. Press the ENTER key. The alarm list will clear and "-----" will be displayed.
 4. Press the ALARM LIST key. "AL" will show on the left display and "-----" on the right display when there are no alarms in the list.
 5. Upon clearing of the Alarm Queue, the Alarm light will be turned off.

Table 3-4 Controller Configuration Variables

CONFIGURATION NUMBER	TITLE	DEFAULT	OPTION
CnF01	Bypass Valve Enable	In	Out
CnF02	Evaporator Fan Speed	dS (Dual)	SS (Single)
CnF03	Control Sensors	FOUR	duAL
CnF04	Dehumidification Mode	On	OFF
CnF05	Reserved for future use	-----	n/a
CnF06	Condenser Fan Speed Select	OFF (Single)	On (Variable)
CnF07	Unit Selection, 20FT/ 40FT/45FT	40ft	20ft,45
CnF08	Single Phase/Three Phase Motor	1Ph	3Ph
CnF09	Refrigerant Selection	r134a	r12, r22, bLEnd
CnF10	Two Speed Compressor Logic	Out (Single)	In (Dual)
CnF11	Defrost "Off" Selection	noOFF	OFF
CnF12	TXV/Solenoid Quench Valve	Out (TXV)	In (Solenoid)
CnF13	Unloader	Out	In
CnF14	Condenser Pressure Control (CPC)	In	Out
CnF15	Discharge Temperature Sensor	Out	In
CnF16	DataCORDER Present	On (Yes)	OFF (No)
CnF17	Discharge Pressure Sensor	Out (No)	In (Yes)
CnF18	Heater	Old (Low Watt)	nEW (High Watt)
CnF19	Controlled Atmosphere	Out (No)	In (Yes)
CnF20	Suction Pressure Sensor	Out (No)	In (Yes)
CnF21	Autotransformer	Out	In
CnF22	Economy Mode Option	OFF	Standard, Full
CnF23	Defrost Interval Timer Save Option	noSAv	SAv
CnF24	Advanced Pre-Trip Enhanced Test Series Option	Auto	Auto2, Auto 3
CnF25	Pre-Trip Test Points/Results Recording Option	rSLtS	dAtA
CnF26	Heat Lockout Change Option	Set to -10°C	Set to -5°C
CnF27	Suction Temperature Display Option	Out	In
CnF28	Bulb Mode Option	NOr	bULb
CnF29	Arctic Mode	Out	In
CnF30	Compressor Size	41 CFM	37 CFM
CnF31	Probe Check Option	Standard	SPEC
CnF32	Single Evaporator Fan Option	2EF0	1EF0
CnF33	Snap Freeze Option	OFF	SnAP
CnF34	Degree Celsius Lockout Option	bOth	F
CnF35	Humidification Mode	OFF	On
CnF36	SMV Type	1 (standard)	2, 3 (stepper)
CnF37	Electronic Temperature Recorder	rEtUR	SUPPL, bOth
CnF38	Quench Bypass Valve	Out	In
CnF39	Expanded Current Limit Range	Out	In
CnF40	Demand Defrost	Out	In
CnF41	Lower DTT Setting	Out	In
CnF42	Auto Pre-trip Start	Out	In
CnF47	Fresh Air Vent Position Sensor	OFF	UPP, LOW
CnF48	CFS Override	OFF	On
CnF49	Datacorder Configuration Restore	OFF	On
CnF50	Enhanced Bulb Mode Selection	OFF	Bulb, dEHUM
CnF51	Timed Defrost Disable	0	0-out, 1-in

Note: Configuration numbers not listed are not used in this application. These items may appear when loading configuration software to the controller but changes will not be recognized by the controller programming.

Table 3-5 Controller Function Codes (Sheet 1 of 4)

Code No.	TITLE	DESCRIPTION
Note: If the function is not applicable, the display will read “-----”		
Display Only Functions		
Cd01	Suction Modulation Valve Opening (%)	Displays the SMV percent open. The right display reads 100% when the valve is fully open and 0% when the valve is fully closed. The valve will usually be at 21% on start up of the unit except in very high ambient temperatures.
Cd02	Quench Valve	Displays state of the solenoid quench valve, open or closed.
Cd03	Not Applicable	Not used
Cd04	Line Current, Phase A	The current sensor measures current on two legs. The third unmeasured leg is calculated based on a current algorithm. The current measured is used for control and diagnostic purposes. For control processing, the highest of the Phase A and B current values is used for current limiting purposes. For diagnostic processing, the current draws are used to monitor component energization. Whenever a heater or a motor is turned ON or OFF, the current draw increase/reduction for that activity is measured. The current draw is then tested to determine if it falls within the expected range of values for the component. Failure of this test will result in a pre-trip failure or a control alarm indication.
Cd05	Line Current, Phase B	
Cd06	Line Current, Phase C	
Cd07	Main Power Voltage	The main supply voltage is displayed.
Cd08	Main Power Frequency	The value of the main power frequency is displayed in Hertz. The frequency displayed will be halved if either fuse F1 or F2 is bad (alarm code AL21).
Cd09	Ambient Temperature	The ambient sensor reading is displayed.
Cd10	Compressor Suction Temperature	Compressor suction temperature sensor reading is displayed.
Cd11	Compressor Discharge Temperature	Compressor discharge temperature sensor reading is displayed.
Cd12	Compressor Suction Pressure	Compressor suction pressure transducer reading is displayed.
Cd13	Condenser Pressure	Condenser pressure transducer reading is displayed.
Cd14	Compressor Discharge Pressure	Compressor discharge pressure transducer reading is displayed.
Cd15	Unloader Valve (On-Off)	Not used in this application
Cd16	Compressor Motor Hour Meter / Switch On Time	Records total hours of compressor run time. Total hours are recorded in increments of 10 hours (i.e., 3000 hours is displayed as 300). / Press 'Enter' to display Start Switch 'ON' time.
Cd17	Relative Humidity (%)	Humidity sensor reading is displayed. This code displays the relative humidity, as a percent value.
Cd18	Software Revision #	The software revision number is displayed.
Cd19	Battery Check	This code checks the Controller/DataCORDER battery pack. While the test is running, “btest” will flash on the right display, followed by the result. “PASS” will be displayed for battery voltages greater than 7.0 volts. “FAIL” will be displayed for battery voltages between 4.5 and 7.0 volts, and “-----” will be displayed for battery voltages less than 4.5 volts. After the result is displayed for four seconds, “btest” will again be displayed, and the user may continue to scroll through the various codes.
Cd20	Config/Model #	This code indicates the dash number of the model for which the Controller is configured (i.e., if the unit is a 69NT40-541-100, the display will show “41100”).
Cd21	Humidity Water Pump/Atomizer Status	This code displays the status of the humidity water pump (-----, forward, reverse or off). If not configured, the mode is permanently deactivated and will display “-----”.
Cd22	Compressor Speed	The status of the compressor is displayed (high, low or off).
Cd23	Evaporator Fan	Displays the current evaporator fan state (high, low or off).

Table 3-5 Controller Function Codes (Sheet 2 of 4)

Code No.	TITLE	DESCRIPTION
Cd24	Controlled Atmosphere State	Not used in this application
Cd25	Compressor Run Time Remaining Until Defrost	This code displays the time remaining until the unit goes into defrost (in tenths of an hour). This value is based on the actual accumulated compressor running time.
Cd26	Defrost Temperature Sensor Reading	Defrost temperature sensor reading is displayed.
Configurable Functions		
NOTE		
Function codes Cd27 through Cd37 are user-selectable functions. The operator can change the value of these functions to meet the operational needs of the container.		
Cd27	Defrost Interval (Hours or Automatic)	<p>There are two modes for defrost initiation, either user-selected timed intervals or automatic control. The user-selected values are (OFF), 3, 6, 9, 12, or 24 hours while the factory default is 12 hours.</p> <p>Automatic defrost starts with an initial defrost at three hours and then adjusts the interval to the next defrost based on the accumulation of ice on the evaporator coil. Following a start-up or after termination of a defrost, the time will not begin counting down until the defrost temperature sensor (DTS) reading falls below set point. If the reading of DTS rises above set point any time during the timer count down, the interval is reset and the countdown begins over.</p> <p>If DTS fails, alarm code AL60 is activated and control switches over to the the return temperature sensor. The controller will act in the same manner as with the DTS except the return temperature sensor reading will be used.</p> <p><i>Defrost Interval Timer Value (Configuration variable CnF23):</i></p> <p>If the software is configured to "SAv" (save) for this option, then the value of the defrost interval timer will be saved at power down and restored at power up. This option prevents short power interruptions from resetting an almost expired defrost interval, and possibly delaying a needed defrost cycle.</p> <p style="text-align: center;">NOTE</p> <p style="text-align: center;">The defrost interval timer counts only during compressor run time.</p>
Cd28	Temperature Units (Degrees C or Degrees F)	<p>This code determines the temperature units (°C or °F) which will be used for all temperature displays. The user selects °C or °F by selecting function code Cd28 and pushing the ENTER key. The factory default value is Celsius units.</p> <p style="text-align: center;">NOTE</p> <p style="text-align: center;">This function code will display "----" if Configuration Variable CnF34 is set to °F.</p>
Cd29	Failure Action (Mode)	<p>If all of the control sensors are out of range (alarm code AL26) or there is a probe circuit calibration failure (alarm code AL27), the unit will enter the shutdown state defined by this setting. The user selects one of four possible actions as follows:</p> <p>A - Full Cooling (stepper motor SMV at maximum allowed opening) B - Partial Cooling (stepper motor SMV 11% open) C - Evaporator Fan Only D - Full System Shutdown - Factory Default</p>
Cd30	In-Range Tolerance	<p>The in-range tolerance will determine the band of temperatures around the set point which will be designated as in-range. If the control temperature is in-range, the in-range light will be illuminated. There are four possible values:</p> <p>1 = +/- 0.5°C (+/-0.9°F) 2 = +/- 1.0°C (+/-1.8°F) 3 = +/- 1.5°C (+/-2.7°F) 4 = +/- 2.0°C (+/-3.6°F) - Factory Default</p>

Table 3-5 Controller Function Codes (Sheet 3 of 4)

Code No.	TITLE	DESCRIPTION
Cd31	Stagger Start Offset Time (Seconds)	The stagger start offset time is the amount of time that the unit will delay at start-up, thus allowing multiple units to stagger their control initiation when all units are powered up together. The eight possible offset values are: 0 (Factory Default), 3, 6, 9, 12, 15, 18 or 21 seconds
Cd32	Current Limit (Amperes)	The current limit is the maximum current draw allowed on any phase at any time. Limiting the unit's current reduces the load on the main power supply. This is accomplished by reducing the SMV position until current draw is reduced to the set point. When desirable, the limit can be lowered. Note, however, that capacity is also reduced. The five values for 460VAC operation are: 15, 17, 19, 21 (Factory Default), 23
Cd33	Perishable Mode Dehumidification / Humidification Control (% RH)	<p>Relative humidity set point is available only on units configured for dehumidification. When the mode is activated, the control probe LED flashes on and off every second to alert the user.</p> <p>If not configured, the mode is permanently deactivated and "-----" will display. The value can be set to "OFF," "TEST," or a range of 65 to 95% relative humidity in increments of 1%. [If bulb mode is active (code Cd35) and "Lo" speed evaporator motors are selected (code Cd36) then set point ranges from 60 to 95%].</p> <p>When "TEST" is selected or test set point is entered, the heat LED should illuminate, indicating that dehumidification mode is activated. After a period of five minutes in the "TEST" mode has elapsed, the previously selected mode is reinstated.</p> <p style="text-align: center;">NOTE</p> <p style="text-align: center;">If humidification (CnF35) is enabled, then humidification will be enabled and dehumidification locked out at set points of 75% and above. At set points below 75%, dehumidification will be enabled and humidification locked out.</p>
Cd34	Economy Mode (On-Off)	Economy mode is a user selectable mode of operation provided for power saving purposes.
Cd35	Bulb Mode	<p>Bulb mode is a user selectable mode of operation that is an extension of dehumidification control (Cd33). If dehumidification is set to "Off," code Cd35 will display "Nor" and the user will be unable to change it.</p> <p>After a dehumidification set point has been selected and entered for code Cd33, the user may then change code Cd35 to "bulb." After bulb has been selected and entered, the user may then utilize function codes Cd36 and Cd37 to make the desired changes.</p>
Cd36	Evaporator Speed Select	<p>This code is enabled only if in the dehumidification mode (code Cd33) and bulb mode (Cd35) has been set to "bulb." If these conditions are not met, "alt" will be displayed (indicating that the evaporator fans will alternate their speed) and the display cannot be changed.</p> <p>If a dehumidification set point has been selected along with bulb mode then "alt" may be selected for alternating speed, "Lo" for low speed evaporator fan only, or "Hi" for high speed evaporator fan only.</p> <p>If a setting other than "alt" has been selected and bulb mode is deactivated in any manner, then selection reverts back to "alt."</p>
Cd37	Defrost Termination Temperature Setting (Bulb Mode)	This code, as with function code Cd36, is used in conjunction with bulb mode and dehumidification. If bulb mode is active, this code allows the user to change the defrost termination thermostat settings. If bulb mode is deactivated, the DTS setting returns to the default.

Table 3-5 Controller Function Codes (Sheet 4 of 4)

Code No.	TITLE	DESCRIPTION
Cd38	Supply Recorder Sensor (SRS)	Code Cd38 will display the current <u>secondary supply temperature sensor reading</u> for units configured for four probes. If the unit is configured with a DataCORDER, Cd38 will display "-----." If the DataCORDER suffers a failure, (AL55) Cd38 will display the supply recorder sensor reading.
Cd39	Return Recorder Sensor (RRS)	Code Cd39 will display the current <u>secondary return temperature sensor reading</u> for units configured for four probes. If the unit is configured with a DataCORDER, Cd39 will display "-----." If the DataCORDER suffers a failure, (AL55) Cd39 will display the return recorder sensor reading.
Cd40	Container Identification Number	Code Cd40 is configured at commissioning to read a valid container identification number. The reading will not display alpha characters, only the numeric portion of the number will display.
Cd41 Cd42	Not Applicable	Scroll Units Only
Cd43	AutoFresh Mode	Code Cd43 is a user selectable mode of operation that allows the opening and closing of a mechanical air vent door via a stepper motor. These selection modes are as follows: OFF - Air makeup vent will remain closed. User - Allows for manual selection of the setting. Delay - The opening of the door is based on selected time, return temperature and flow rate (percent opened). gASLM - The opening is based percent open and CO2 and O2 selectable limits (LM). This selection is only active if the unit has a CO2 sensor. TEST / CAL (CO2 sensor option units only) - The door will fully open and close to allow the user to inspect its operation. If CAL is selected, the controller will zero calibrate the CO2 sensor input. If the unit is not configured with AutoFresh, the CD43 will display "-----"
Cd44	AutoFresh Values	Code Cd44 will display CO2 and O2 concentrations and limits. If the unit is not configured for AutoFresh or a CO2 sensor is not installed, CD44 will display "-----"
Cd45	Vent Position Sensor (VPS)	Code Cd45 will display whenever the control detects movement via the sensor unless alarm 50 is active. The code will display for 30 seconds, then time out and return to the normal display mode. If the Temperature unit is degrees F, the VPS units will be CFM and in degrees C the VPS units shall be CMH.
Cd46	Not Used	-
Cd47	Variable Economy Temperature Setting	The variable temperature "degrees C or degrees F" setting is used with economy mode. Function code is "-----" when unit is not configured for economy mode.
Cd48	Dehumidification/ Bulb Mode Parameter Selection	Code CD48 is used to determine limits (between 60%-95%) for dehumidification and/or bulb mode (CNF28) when active.
Cd49	Days Since Last Successful Pre-trip	Code CD49 will display the number of days since the last successful Auto1, Auto2 or Auto3 pre-trip sequence.

Table 3-6 Controller Alarm Indications (Sheet 1 of 4)

Code No.	TITLE	DESCRIPTION
AL05	Manual Defrost Switch Failure	Alarm 05 is triggered if the controller detects continuous Manual Defrost Switch action for five minutes or more. The alarm will only trigger off when the unit is power cycled.
AL06	Keypad or Harness Failure	Alarm 06 is triggered if the controller detects continuous keypad button activity for five minutes or more. The alarm will only trigger off when the unit is power cycled.
AL07	Fresh Air Vent Open with Frozen Set Point	Alarm 07 is triggered if the VPS is reading greater than 0 CMH based on the function code display value and a frozen set point is active. If AL 50 is active, AL 07 will not be generated. The alarm will go inactive if the VPS reading transitions to 0 CMH, the set point transitions to the perishable range, or an AL50 is active.
AL10	CO ₂ Sensor Failure	Alarm 10 is triggered when the CO ₂ sensor voltage is operating outside of the 0.9 v to 4.7 v range, or if the sensor is out of range. This is a display alarm and has no associated failure action.
AL11	Evaporator Motor 1 IP Trip	Alarm 11 is applicable to units with Single Evaporator Fan Capability (CnF32 set to 1EFO) only. The alarm is triggered if the evaporator fan motor #1 internal protector opens. If the alarm is active, probe check is deactivated.
AL12	Evaporator Motor 2 IP Trip	Alarm 12 is applicable to units with Single Evaporator Fan Capability (CnF32 set to 1EFO) only. The alarm is triggered if the evaporator fan motor #2 internal protector opens. If the alarm is active, probe check is deactivated.
AL15	Loss of Cool	Alarm 15 is activated when SMV is greater than 15%, unit is in economized or standard operating modes and Return - Supply Temperature Difference is less than 0.5C after 4 minutes of compressor run time. The alarm triggers failure action C (evaporator fan only) or D (all machinery off) if in perishable mode and failure action D (all machinery off) if a frozen set point has been selected.. The alarm remains active until the unit is power cycled.
AL20	Control Circuit Fuse Open (24 vac)	Alarm 20 is triggered by control power fuse (F3A, F3B) opening and will cause the software shutdown of all control units. This alarm will remain active until the fuse is replaced.
AL21	Micro Circuit Fuse Open (18 vac)	Alarm 21 is triggered by one of the fuses (F1/F2) being opened on 18 volts AC power supply to the Controller. The suction modulation valve (SMV) will be opened and current limiting is halted. Temperature control will be maintained by cycling the compressor.
AL22	Evaporator Fan Motor Safety	Alarm 22 responds to the evaporator motor internal protectors. On units with Normal Evaporator Fan Operation (CnF32 set to 2EFO) the alarm is triggered by opening of either internal protector. It will disable all control units until the motor protector resets. On units with Single Evaporator Fan Capability (CnF32 set to 1EFO), the alarm is triggered by opening of both internal protectors. It will disable all control units until a motor protector resets.
AL24	Compressor Motor Safety	Alarm 24 is triggered by the opening of the compressor motor internal protector. This alarm will disable all control units except for the evaporator fans and will remain active until the motor protector resets. This alarm triggers the failure action code set by Function Code Cd29.
AL25	Condenser Fan Motor Safety	Alarm 25 is triggered by the opening of the condenser motor internal protector and will disable all control units except for the evaporator fans. This alarm will remain active until the motor protector resets. This alarm is deactivated if the unit is operating on water cooled condensing.
AL26	All Supply and Return temperature Control Sensors Failure	Alarm 26 is triggered if the Controller determines that all of the control sensors are out-of-range. This can occur for box temperatures outside the range of -50°C to +70°C (-58°F to +158°F). This alarm triggers the failure action code set by Function Code Cd29.
AL27	Probe Circuit Calibration Failure	The Controller has a built-in Analog to Digital (A-D) converter, used to convert analog readings (i.e. temperature sensors, current sensors, etc.) to digital readings. The Controller continuously performs calibration tests on the A-D converter. If the A-D converter fails to calibrate for 30 consecutive seconds, this alarm is activated. This alarm will be inactivated as soon as the A-D converter calibrates.

Table 3-6 Controller Alarm Indications (Sheet 2 of 4)

Code No.	TITLE	DESCRIPTION
AL29	AutoFresh Failure	Alarm 29 is triggered if CO ₂ or O ₂ level is outside of the limit range and the vent position is at 100% for longer than 90 minutes. Alarm LED will be activated and user intervention is required. The alarm is triggered off when atmospheric conditions are within limit settings.
AL50	Fresh Air Position Sensor (VPS)	Alarm 50 is activated whenever the sensor is outside the valid range. There is a five minute adjustment period where the user can change the vent position without generating an alarm event. The sensor requires five minutes of no movement to confirm stability. If the vent position changes at any point beyond the five minute adjustment period, the sensor will generate an alarm event. The alarm is triggered off when the unit power cycles and the sensor is within valid range.
AL51	Alarm List Failure	<p>During start-up diagnostics, the EEPROM is examined to determine validity of its contents. This is done by testing the set point and the alarm list. If the contents are invalid, Alarm 51 is activated.</p> <p>During control processing, any operation involving alarm list activity that results in an error will cause Alarm 51 to be activated. Alarm 51 is a “display only” alarm and is not written into the alarm list.</p> <p>Pressing the ENTER key when “CLEAR” is displayed will result in an attempt to clear the alarm list. If that action is successful (all alarms are inactive), Alarm 51 will be reset.</p>
AL52	Alarm List Full	Alarm 52 is activated whenever the alarm list is determined to be full; at start-up or after recording an alarm in the list. Alarm 52 is displayed, but is not recorded in the alarm list. This alarm can be reset by clearing the alarm list. This can be done only if all alarms written in the list are inactive.
AL53	Battery Pack Failure	<p>Alarm 53 is caused by the battery pack charge being too low to provide sufficient power for battery-backed recording. Renew replaceable batteries.</p> <p>If this alarm occurs on start up, allow a unit fitted with rechargeable batteries to operate for up to 24 hours to charge rechargeable batteries sufficiently to deactivate the alarm</p>
AL54	Primary Supply Temperature Sensor Failure (STS)	<p>Alarm 54 is activated by an invalid primary supply temperature sensor reading that is sensed outside the range of -50 to +70°C (-58°F to +158°F) or if the probe check logic has determined there is a fault with this sensor.</p> <p>If Alarm 54 is activated and the primary supply is the control sensor, the secondary supply sensor will be used for control if the unit is so equipped. If the unit does not have a secondary supply temperature sensor, and AL54 is activated, the primary return sensor reading, minus 2°C will be used for control.</p> <p style="text-align: center;">NOTE</p> <p style="text-align: center;">The P5 Pre-Trip test must be run to inactivate the alarm</p>
AL56	Primary Return Temperature Sensor Failure (RTS)	<p>Alarm 56 is activated by an invalid primary return temperature sensor reading that is outside the range of -50 to +70°C (-58°F to +158°F). If Alarm 56 is activated and the primary return is the control sensor, the secondary return sensor will be used for control if the unit is so equipped. If the unit is not equipped with a secondary return temperature sensor or it fails, the primary supply sensor will be used for control.</p> <p style="text-align: center;">NOTE</p> <p style="text-align: center;">The P5 Pre-Trip test must be run to inactivate the alarm.</p>
AL57	Ambient Temperature Sensor Failure	Alarm 57 is triggered by an ambient temperature reading outside the valid range from -50 to +70°C (-58°F to +158°F).
AL58	Compressor High Pressure Safety	Alarm 58 is triggered when the compressor high discharge pressure safety switch remains open for at least one minute. This alarm will remain active until the pressure switch resets, at which time the compressor will restart.
AL59	Heat Termination Thermostat	Alarm 59 is triggered by the opening of the heat termination thermostat and will result in the disabling of the heater. This alarm will remain active until the thermostat resets.

Table 3-6 Controller Alarm Indications (Sheet 3 of 4)

Code No.	TITLE	DESCRIPTION
AL60	Defrost Temperature Sensor Failure	<p>Alarm 60 is an indication of a probable failure of the defrost temperature sensor (DTS). It is triggered by the opening of the heat termination thermostat (HTT) or the failure of the DTS to go above set point within two hours of defrost initiation.</p> <p>After one-half hour with a frozen range set point, or one-half hour of continuous compressor run time, if the return air falls below 7°C (45°F), the Controller checks to ensure the DTS reading has dropped to 10°C or below.</p> <p>If not, a DTS failure alarm is given and the defrost mode is operated using the return temperature sensor. The defrost mode will be terminated after one hour by the Controller.</p>
AL61	Heaters Failure	<p>Alarm 61 is triggered by detection of improper amperage resulting from heater activation or deactivation. Each phase of the power source is checked for proper amperage. This alarm is a display alarm with no resulting failure action, and will be reset by a proper amp draw of the heater.</p>
AL62	Compressor Circuit Failure	<p>Alarm 62 is triggered by improper current draw increase (or decrease) resulting from compressor turn on (or off). The compressor is expected to draw a minimum of 2 amps; failure to do so will activate the alarm. This is a display alarm with no associated failure action and will be reset by a proper amp draw of the compressor.</p>
AL63	Current Over Limit	<p>Alarm 63 is triggered by the current limiting system. If the compressor is ON and current limiting procedures cannot maintain a current level below the user selected limit, the current limit alarm is activated.</p> <p>This alarm is a display alarm and is inactivated by power cycling the unit, changing the current limit via the code select Cd32, or if the suction modulation valve (SMV) is open beyond the controller desired point.</p>
AL64	Discharge Temperature Over Limit	<p>Alarm 64 is triggered if the discharge temperature sensed is greater than 135°C (275°F) for three continuous minutes, if it exceeds 149°C (300°F), or if the sensor is out of range. This is a display alarm and has no associated failure action.</p>
AL65	Discharge Pressure Transducer Failure	<p>Alarm 65 is triggered by a compressor discharge transducer reading outside the valid range of 73.20cm Hg (30in Hg) to 32.34Kg/cm² (460psig). This is a display alarm and has no associated failure action.</p>
AL66	Suction Pressure Transducer Failure	<p>Alarm 66 is triggered by a suction pressure transducer reading outside the valid range of 73.20cm Hg (30in Hg) to 32.34Kg/cm² (460psig). This is a display alarm and has no associated failure action.</p>
AL67	Humidity Sensor Failure	<p>Alarm 67 is triggered by a humidity sensor reading outside the valid range of 0% to 100% relative humidity. If alarm AL67 is triggered when the dehumidification mode is activated, then the dehumidification mode will be deactivated.</p>
AL68	Condenser Pressure Transducer Failure	<p>Alarm 68 is triggered by a condenser pressure transducer reading outside the valid range of 73.20cm Hg (30in Hg) to 32.34Kg/cm² (460psig). This is a display alarm and has no associated failure action.</p>
AL69	Suction Temperature Sensor Failure	<p>Alarm 69 is triggered by a suction temperature sensor reading outside the valid range of -60°C (-76°F) to 150°C (302°F). This is a display alarm and has no associated failure action.</p>
<p style="text-align: center;">NOTE</p> <p>If the controller is configured for four probes without a DataCORDER, the DataCORDER alarms AL70 and AL71 will be processed as Controller alarms AL70 and AL71.</p>		

Table 3-7 Controller Pre-Trip Test Codes (Sheet 1 of 4)

NOTE		
<p>“Auto” or “Auto1” menu includes: P, P1, P2, P3, P4, P5, P6 & rSLts. “Auto2” menu includes P, P1, P2, P3, P4, P5, P6, P7, P8, P9, P10 & rSLts. “Auto3 menu includes P, P1, P2, P3, P4, P5, P6, P7, P8 & rSLts</p>		
P	Pre-Trip Initiated	All lights and display segments will be energized for five seconds at the start of the pre-trip. Since the unit cannot recognize lights and display failures, there are no test codes or results associated with this phase of pre-trip.
P1-0	Heaters Turned On	Setup: Heater must start in the OFF condition, and then be turned on. A current draw test is done after 15 seconds. Pass/Fail Criteria: Passes if current draw change is within the range specified.
P1-1	Heaters Turned Off	Setup: Heater must start in the ON condition, and then be turned off. A current draw test is done after 10 seconds. Pass/Fail Criteria: Passes if current draw change is within the range specified.
P2-0	Condenser Fan On	Requirements: Water pressure switch (WP) input must be closed. Setup: Condenser fan is turned ON, a current draw test is done after 15 seconds. Pass/Fail Criteria: Passes if current draw change is within the range specified.
P2-1	Condenser Fan Off	Setup: Condenser fan is turned OFF, a current draw test is done after 10 seconds. Pass/Fail Criteria: Passes if current draw change is within the range specified.
P3	Low Speed Evaporator Fans	Requirements: The unit must be equipped with a low speed evaporator fan, as determined by the Evaporator Fan speed select configuration variable. NOTE If the unit is configured for single evaporator fan operation, Pre-Trip tests P3-0, P3-1, P4-0 and P4-1 will fail immediately if Controller alarm codes AL11 or AL12 are active at the start of testing.
P3-0	Low Speed Evaporator Fan Motors On	Setup: The high speed evaporator fans will be turned on for 10 seconds, then off for two seconds, then the low speed evaporator fans are turned on. A current draw test is done after 60 seconds. Pass/Fail Criteria: Passes if change in current draw is within the range specified. Fails if AL11 or AL12 activates during test.
P3-1	Low Speed Evaporator Fan Motors Off	Setup: The low speed Evaporator Fan is turned off, a current draw test is done after 10 seconds. Pass/Fail Criteria: Passes if change in current draw is within the range specified. Fails if AL11 or AL12 activates during test.
P4-0	High Speed Evaporator Fan Motors On	Setup: The high speed Evaporator Fan is turned on, a current draw test is done after 60 seconds. Pass/Fail Criteria: Passes if change in current draw is within the range specified. Fails if AL11 or AL12 activates during test.
P4-1	High Speed Evaporator Fan Motors Off	Setup: The high speed Evaporator Fan is turned off, a current draw test is done after 10 seconds. Pass/Fail Criteria: Passes if change in current draw is within the range specified. Fails if AL11 or AL12 activates during test.
P5-0	Supply/Return Probe Test	Setup: The High Speed Evaporator Fan is turned on and run for eight minutes, with all other outputs de-energized. Pass/Fail Criteria: A temperature comparison is made between the return and supply probes. NOTE If this test fails, “P5-0” and “FAIL” will be displayed. If both Probe tests (this test and the PRIMARY/ SECONDARY) pass, the display will read “P5” “PASS.”
P5-1	Supply Probe Test	Requirements: For units equipped with secondary supply probe only. Pass/Fail Criteria: The temperature difference between primary and secondary probe (supply) is compared. NOTE If this test fails, “P5-1” and FAIL will be displayed. If both Probe tests (this and the SUPPLY/ RETURN TEST) pass, because of the multiple tests, the display will read ‘P 5’ ‘PASS’.

Table 3-7 Controller Pre-Trip Test Codes (Sheet 2 of 4)

Code No.	TITLE	DESCRIPTION
P5-2	Return Probe Test	<p>Requirements: For units equipped with secondary return probe only. Pass/Fail Criteria: The temperature difference between primary and secondary probe (return) is compared.</p> <p align="center">NOTES</p> <ol style="list-style-type: none"> 1. If this test fails, "P5-2" and "FAIL" will be displayed. If both Probe tests (this test and the SUPPLY/ RETURN) pass, because of the multiple tests, the display will read "P 5," "PASS." 2. The results of Pre-Trip tests 5-0, 5-1 and 5-2 will be used to activate or clear control probe alarms.
P5-10	Humidity Sensor Controller Configuration Verification Test	<p>Requirements: Test P5-9 must pass before this test is run. Test is skipped if controller is not configured for the humidity sensor and the voltage is less than 0.20 volts. Pass/Fail Criteria: Passes if controller configuration has the humidity sensor installed. Fails if controller is not configured for humidity sensor and the voltage is greater than 0.20 volts.</p>
P5-11	Humidity Sensor Installation Verification Test	<p>Requirements: Test P5-10 must pass before this test is run. Pass/Fail Criteria: Passes if voltage is greater than 0.20 volts for the humidity sensor. Fails if voltage is less than 0.20 volts for the humidity sensor.</p>
P5-12	Humidity Sensor Range Check Test	<p>Requirements: Test P5-11 must pass before this test is run. Pass/Fail Criteria: Passes if the voltage for the humidity sensor is between 0.66 volts and 4 volts. Fails if voltage is outside of the 0.66 volt to 4 volt range.</p>
P-6		Not Applicable
P6-0	Compressor On	<p>Setup: A current draw test is performed before the compressor is started. The compressor is started. SMV is opened and another current draw test is performed. Pass/Fail Criteria: Passes if the change in compressor current draw is within the specified range.</p>
P6-H & P6L		Not Applicable
P6-2	Suction Modulation Valve (Open and Closed)	<p>Setup: The compressor and fans continue to run from the previous test. The quench valve (if configured) will operate as in normal control mode. The SMV is closed to 0% open, current and condenser pressure readings are taken. The SMV is opened to 50% with continuous current and condenser pressure readings taken to establish maximum values. The SMV is returned to 0% open and final readings are taken. Pass/Fail Criteria: Passes if the calculated difference in current at the 50% open position are above a specified value before and after opening of the SMV, OR the calculated difference in condenser pressure at the 50% open position are above a specified value before and after opening of the SMV</p>
P6-3	Quench Valve Test	<p>Setup: The compressor suction temperature is measured with the Quench valve closed. The Quench valve is energized and the suction temperature drop is checked. Pass/Fail Criteria: Passes if suction temperature is within the valid range.</p>
P6-4	Not Applicable	Not Used
P6-5	Not Applicable	Not Used

Table 3-7 Temperature Controller Pre-Trip Test Codes (Sheet 3 of 4)

Code No.	TITLE	DESCRIPTION
<p>NOTE P7-0 & P8 are included with the “Auto2 & Auto 3” only. P9-0 through P10 are included with “Auto2” only</p>		
P7-0	High Pressure Switch Closed	<p>Setup: When the unit is running, the condenser fan is de-energized, and a 15 minute timer is started. The right display shows discharge pressure if the unit is equipped with a discharge pressure transducer (DPT). If no DPT is installed, the condenser pressure transducer (CPT) reading will be displayed. Pass/Fail Criteria: The test fails if high pressure switch fails to open in 15 minutes.</p> <p>Note, this test is skipped if the unit does NOT have: A compressor discharge sensor (CPDS). A discharge pressure transducer (DPT). Condenser pressure transducer (CPT).</p> <p>In addition, this test is skipped if: The sensed ambient temperature is less than 7°C (45°F). The return air temperature is less than -17.8°C (0°F). The water pressure switch (WP) is open, indicating that the unit is operating with a water-cooled condenser.</p> <p>Pass/Fail Criteria: Under conditions of the above NOTE; the test immediately fails if the following inputs are sensed to be invalid: Compressor discharge sensor (CPDS). Discharge pressure transducer (DPT). Condenser pressure transducer (CPT).</p> <p>OR, if any one of the following inputs are sensed to be invalid: Return temperature sensor (RTS). Ambient sensor (AMBS).</p> <p>In addition, the test will fail if: The high pressure switch (HPS) fails to open within 15 minutes. The discharge temperature exceeds 138°C (280°F). The discharge temperature is less than or equal to ambient temperature plus 5°C (9°F). The condenser pressure transducer (CPT) or discharge pressure transducer (DPT) pressure exceeds 27.42kg/cm₂ (390psig).</p>
P7-1	High Pressure Switch Open	<p>Requirement: Test P7-0 must pass for this test to execute. Setup: The condenser fan is started and a 60 second timer is started. Pass/Fail Criteria: Passes the test if the high pressure switch (HPS) closes within the 60-second time limit, otherwise, it fails.</p>
P8-0	Perishable Mode Heat Test	<p>Setup: If the container temperature is below 15.6°C (60°F), the set point is changed to 15.6°C, and a 60-minute timer is started. The left display will read “P8-0.” The control will then heat the container until 15.6°C is reached. If the container temperature is above 15.6°C at the start of the test, then the test proceeds immediately to test P8-1 and the left display will change to “P8-1.” Pass/Fail Criteria: The test fails if the 180-minute timer expires before the control temperature reaches set point. The display will read “P8-0,” “FAIL.”</p>

Table 3-7 Controller Pre-Trip Test Codes (Sheet 4 of 4)

Code No.	TITLE	DESCRIPTION
P8-1	Perishable Mode Pull Down Test	<p>Requirements: Control temperature must be at least 15.6°C (60°F).</p> <p>Setup: The set point is changed to 0°C (32°F), and a 180-minute timer is started. The left display will read “P8-1,” the right display will show the supply air temperature. The unit will then start to pull down the temperature to the 0°C set point.</p> <p>Pass/Fail Criteria: The test passes if the container temperature reaches set point before the 180-minute timer expires.</p>
P8-2	Perishable Mode Maintain Temperature Test	<p>Requirements: Test P8-1 must pass for this test to execute.</p> <p>Setup: The left display will read “P8-2,” and the right display will show the supply air temperature. A 60-minute timer is started. The unit will be required to maintain the 0°C temperature to within +/-0.5°C (0.9°F) of set point until a DataCORDER recording is executed.</p> <p>The recorder supply probe temperature running total (and its associated readings counter) will be zeroed out for the remainder of the recording period at the start of this test, so that the actual value recorded in the DataCORDER will be an average of only this test’s results.</p> <p>Once a recording interval is complete, the average recorder supply temperature will be recorded in the DataCORDER, as well as stored in memory for use in applying the test pass/fail criteria.</p> <p>Pass/Fail Criteria: If the recorded temperature is within +/-0.5°C. of set point from test start to DataCORDER recording, the test passes. If the average temperature is outside of the tolerance range at the recording, the test fails.</p>
P9-0	Defrost Test	<p>Setup: The defrost temperature sensor (DTS) reading will be displayed on the left display. The right display will show the supply air temperature. The unit will run FULL COOL for 30 minutes maximum until the DTT is considered closed. Once the DTT is considered closed, the unit simulates defrost by running the heaters for up to two hours, or until the DTT is considered open.</p> <p>Pass/Fail Criteria: The test fails if: the DTT is not considered closed after the 30 minutes of full cooling, HTT opens when DTT is considered closed or if return air temperature rises above 248°C (120°F).</p>
P10-0	Frozen Mode Setup Test	<p>Setup: After completion of the defrost test, the testing proceeds directly to test P10-1 if the container temperature is above 7°C (45°F). If the container temperature is below 7°C, a 180-minute timer will be started, the set point will be set to 7°C and the control will be placed in normal heat. The left display will read “P10-0” and the unit will continue in operation until the temperature is raised to set point.</p> <p>Pass/Fail Criteria: If the temperature does not reach set point (less -0.3°C or 6.7°F) before the timer times out display will read “P100,” “FAIL.” The test will not auto-repeat.</p>
P10-1	Frozen Mode (Pull Down) Test	<p>Setup: When the container temperature is greater than or equal to the 7.2°C (45°F) set point which was set in the Frozen Mode Setup Test, the left display will read “P10-1” and the right display will show the return air temperature. The set point will then be changed to -17.7°C (0°F). The unit will then have a maximum of three hours to pull the container temperature down to the -17.7°C set point.</p> <p>Pass/Fail Criteria: If this occurs within the three hour time limit, the test passes. If pulldown is not completed within the three hour time, the test fails.</p>
P10-2	Frozen Mode Maintain Temperature Test	<p>Setup: After the unit has successfully completed frozen pulldown test, the left display will read “P10-2” and the right display will show return air temperature. The unit will then be required to maintain -17.7°C (0°F) temperature within +/-0.5°C (0.9°F) of set point until a DataCORDER recording is executed.</p> <p>The recorder return probe temperature running total (and its associated counter) will be zeroed for the remainder of the recording period at the start of this test, so that the actual recorded value will be an average of only this test’s results.</p> <p>Once the recording interval is complete, the average return temperature will be recorded in the DataCORDER, and stored in memory for use in applying the test pass/fail criteria.</p> <p>Pass/Fail Criteria: If the recorded temperature is within +/-0.5°C of set point from test start to DataCORDER recording, the test passes. If temperature is outside of the tolerance range at the DataCORDER recording, the test fails.</p>

Table 3-8 DataCORDER Function Code Assignments

NOTE Inapplicable Functions Display “-----” To Access: Press ALT. MODE key		
Code No.	TITLE	DESCRIPTION
dC1	Recorder Supply Temperature	Current reading of the supply recorder sensor.
dC2	Recorder Return Temperature	Current reading of the return recorder sensor.
dC3-5	USDA 1,2,3 Temperatures	Current readings of the three USDA probes.
dC6-13	Network Data Points 1-8	Current values of the network data points (as configured). Data point 1 (Code 6) is generally the humidity sensor and its value is obtained from the Controller once every minute.
dC14	Cargo Probe 4 Temperature	Current reading of the cargo probe #4.
dC15-19	Future Expansion	These codes are for future expansion, and are not in use at this time.
dC20-24	Temperature Sensors 1-5 Calibration	Current calibration offset values for each of the five probes: supply, return, USDA #1, #2, and #3. These values are entered via the interrogation program.
dC25	Future Expansion	This code is for future expansion, and is not in use at this time.
dC26,27	S/N, Left 4, Right 4	The DataCORDER serial number consists of eight characters. Function code dC26 contains the first four characters. Function code dC27 contains the last four characters. (This serial number is the same as the Controller serial number)
dC28	Minimum Days Left	An approximation of the number of logging days remaining until the DataCORDER starts to overwrite the existing data.
dC29	Days Stored	Number of days of data that are currently stored in the DataCORDER.
dC30	Date of last Trip start	The date when a Trip Start was initiated by the user. In addition, if the system goes without power for seven continuous days or longer, a trip start will automatically be generated on the next AC power up.
dC31	Battery Test	Shows the current status of the optional battery pack. PASS: Battery pack is fully charged. FAIL: Battery pack voltage is low.
dC32	Time: Hour, Minute	Current time on the real-time clock (RTC) in the DataCORDER.
dC33	Date: Month, Day	Current date (month and day) on the RTC in the DataCORDER.
dC34	Date: Year	Current year on the RTC in the DataCORDER.
dC35	Cargo Probe 4 Calibration	Current calibration value for the Cargo Probe. This value is an input via the interrogation program.

Table 3-9 DataCORDER Pre-Trip Result Records

Test No.	TITLE	DATA
1-0	Heater On	Pass/Fail/Skip Result, Change in current for Phase A, B and C
1-1	Heater Off	Pass/Fail/Skip Result, Change in currents for Phase A, B and C
2-0	Condenser Fan On	Pass/Fail/Skip Result, Water pressure switch (WPS) - Open/Closed, Change in currents for Phase A, B and C
2-1	Condenser Fan Off	Pass/Fail/Skip Result, Change in currents for Phase A, B and C
3-0	Low Speed Evaporator Fan On	Pass/Fail/Skip Result, Change in currents for Phase A, B and C
3-1	Low Speed Evaporator Fan Off	Pass/Fail/Skip Result, Change in currents for Phase A, B and C
4-0	High Speed Evaporator Fan On	Pass/Fail/Skip Result, Change in currents for Phase A, B and C
4-1	High Speed Evaporator Fan Off	Pass/Fail/Skip Result, Change in currents for Phase A, B and C
5-0	Supply/Return Probe Test	Pass/Fail/Skip Result, STS, RTS, SRS and RRS
5-1	Secondary Supply Probe Test	Pass/Fail/Skip Result
5-2	Secondary Return Probe Test	Pass/Fail/Skip Result
6-0	Compressor On	Pass/Fail/Skip Result, Change in currents for Phase A, B and C
6-1	Not Applicable	Not Used
6-2	Suction Modulation Valve Open and Closed	Pass/Fail/Skip Result, Is current or pressure limit in effect (Y,N)
6-4	Not Applicable	Not Used
6-5	Not Applicable	Not Used
7-0	High Pressure Switch Closed	Pass/Fail/Skip Result, AMBS, DPT or CPT (if equipped) Input values that component opens
7-1	High Pressure Switch Open	Pass/Fail/Skip Result, STS, DPT or CPT (if equipped) Input values that component closes
8-0	Perishable Heat	Pass/Fail/Skip Result, STS, time it takes to heat to 16°C (60°F)
8-1	Perishable Pull Down	Pass/Fail/Skip Result, STS, time it takes to pull down to 0°C (32°F)
8-2	Perishable Maintain	Pass/Fail/Skip Result, Averaged DataCORDER supply temperature (SRS) over last recording interval.
9-0	Defrost Test	Pass/Fail/Skip Result, DTS reading at end of test, line voltage, line frequency, time in defrost.
10-0	Frozen Mode Set-up	Pass/Fail/Skip Result, STS, time unit is in heat.
10-1	Frozen Mode Pull Down	Pass/Fail/Skip Result, STS, time to pull down unit to -17.8°C (0°F).
10-2	Frozen Mode Maintain	Pass/Fail/Skip Result, Averaged DataCORDER return temperature (RRS) over last recording interval.

Table 3-10 DataCORDER Alarm Indications

To Access: Press ALT. MODE key		
Code No.	TITLE	DESCRIPTION
dAL70	Recorder Supply Temperature Out of Range	The supply recorder sensor reading is outside of the range of -50 to 70°C (-58°F to +158°F) or, the probe check logic has determined there is a fault with this sensor. NOTE The P5 Pre-Trip test must be run to inactivate the alarm.
dAL71	Recorder Return Temperature Out of Range	The return recorder sensor reading is outside of the range of -50 to 70°C (-58°F to +158°F) or, the probe check logic has determined there is a fault with this sensor. NOTE The P5 Pre-Trip test must be run to inactivate the alarm.
dAL72-74	USDA Temperatures 1, 2, 3 Out of Range	The USDA probe temperature reading is sensed outside of -50 to 70°C (-58 to 158°F) range.
dAL75	Cargo Probe 4 Out of Range	The cargo probe temperature reading is outside of -50 to 70°C (-58 to 158°F) range.
dAL76, 77	Future Expansion	These alarms are for future expansion, and are not in use at this time.
dAL78-85	Network Data Point 1 - 8 Out of Range	The network data point is outside of its specified range. The DataCORDER is configured by default to record the supply and return recorder sensors. The DataCORDER may be configured to record up to 8 additional network data points. An alarm number (AL78 to AL85) is assigned to each configured point. When an alarm occurs, the DataCORDER must be interrogated to identify the data point assigned. When a humidity sensor is installed, it is usually assigned to AL78.
dAL86	RTC Battery Low	The Real Time Clock (RTC) backup battery is too low to adequately maintain the RTC reading.
dAL87	RTC Failure	An invalid date or time has been detected. This situation may be corrected by changing the Real Time Clock (RTC) to a valid value using DataLINE.
dAL88	DataCORDER EEPROM Failure	A write of critical DataCORDER information to the EEPROM has failed.
dAL89	Flash Memory Error	An error has been detected in the process of writing daily data to the non-volatile FLASH memory.
dAL90	Future Expansion	This alarm is for future expansion, and is not in use at this time.
dAL91	Alarm List Full	The DataCORDER alarm queue is determined to be full (eight alarms).

SECTION 4 OPERATION

4.1 INSPECTION (Before Starting)



Beware of unannounced starting of the evaporator and condenser fans. The unit may cycle the fans and compressor unexpectedly as control requirements dictate.

- a. If container is empty, check inside for the following:
 1. Check channels or “T” bar floor for cleanliness. Channels must be free of debris for proper air circulation.
 2. Check container panels, insulation, and door seals for damage. Make permanent or temporary repairs.
 3. Visually check evaporator fan motor mounting bolts for proper securement (refer to paragraph 6.16).
 4. Check for dirt or grease on evaporator fan or fan deck and clean if necessary.
 5. Check evaporator coil for cleanliness or obstructions. Wash with fresh water.
 6. Check defrost drain pans and lines for obstructions and clear if necessary. Wash with fresh water.
 7. Check panels on refrigeration unit for loose bolts and condition of panels. Make sure T.I.R. devices are in place on access panels.
- b. Check condenser coil for cleanliness. Wash with fresh water.
- c. Open control box door. Check for loose electrical connections or hardware.
- d. Check color of moisture-liquid indicator.
- e. Check oil level in compressor sight glass.

4.2 CONNECT POWER



Do not attempt to remove power plug(s) before turning OFF start-stop switch (ST), unit circuit breaker(s) and external power source.



Make sure the power plugs are clean and dry before connecting to any power receptacle.

4.2.1 Connection To 380/460 VAC Power

1. Make sure start-stop switch (ST, on control panel) and circuit breaker (CB-1, in the control box) are in position “O” (OFF).
2. Plug the 460VAC (yellow) cable into a de-energized 380/460VAC, 3-phase power source. Energize the power source. Place circuit breaker (CB-1) in position “I” (ON). Close and secure control box door.

4.2.2 Connection to 190/230 VAC Power

An autotransformer (Figure 4-1) is required to allow operation on nominal 230 volt power. It is fitted with a 230VAC cable and a receptacle to accept the standard 460VAC power plug. The 230 volt cable is black in color while the 460 volt cable is yellow. The transformer may also be equipped with a circuit breaker (CB-2). The transformer is a step-up transformer that will provide 380/460VAC, 3-phase, 50/60 hertz power to the unit when the 230VAC power cable is connected to a 190/230VAC, 3-phase power source.

1. Make sure that the start-stop switch (ST, on control panel) and circuit breakers CB-1 (in the control box) and CB-2 (on the transformer) are in position “O” (OFF). Plug in and lock the 460VAC power plug at the receptacle on the transformer.
2. Plug the 230VAC (black) cable into a de-energized 190/230VAC, 3-phase power source. Energize the power source. Set circuit breakers CB-1 and CB2 to position “I” (ON). Close and secure control box door.

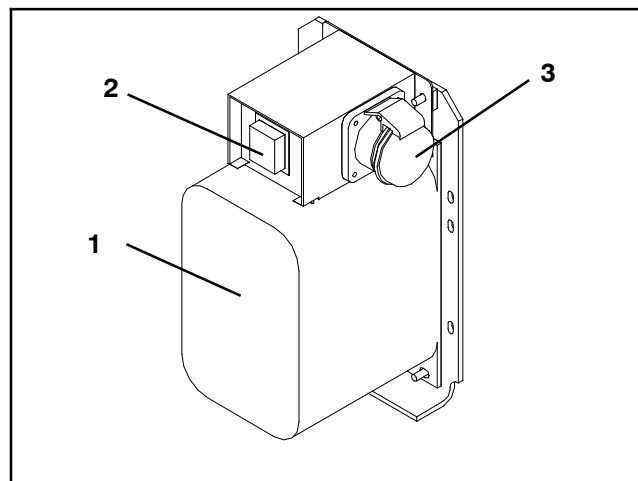

1. Dual Voltage Modular Autotransformer
2. Circuit Breaker (CB-2) 230V
3. 460VAC Power Receptacle

Figure 4-1 Autotransformer

4.3 ADJUST FRESH AIR MAKEUP VENT

The purpose of the fresh air makeup vent is to provide ventilation for commodities that require fresh air circulation. The vent *must be closed* when transporting frozen foods.

Air exchange depends on static pressure differential, which will vary depending on the container and how the container is loaded.

Units may be equipped with a vent position sensor (VPS). The VPS determines the position of the fresh air vent and sends data to the controller display.

4.3.1 Upper Fresh Air Makeup Vent

Two slots and a stop are designed into the disc for air flow adjustments. The first slot allows for a 0 to 30% air flow and the second slot allows for a 30 to 100% air flow.

To adjust the percentage of air flow, loosen the wing nut and rotate the disc until the desired percentage of air flow matches with the arrow. Tighten the wing nut.

To clear the gap between the slots, loosen the wing nut until the disc clears the stop. Figure 4-2 gives air exchange values for an empty container. Higher values can be expected for a fully loaded container.

69NT40 FRESH AIR MAKEUP

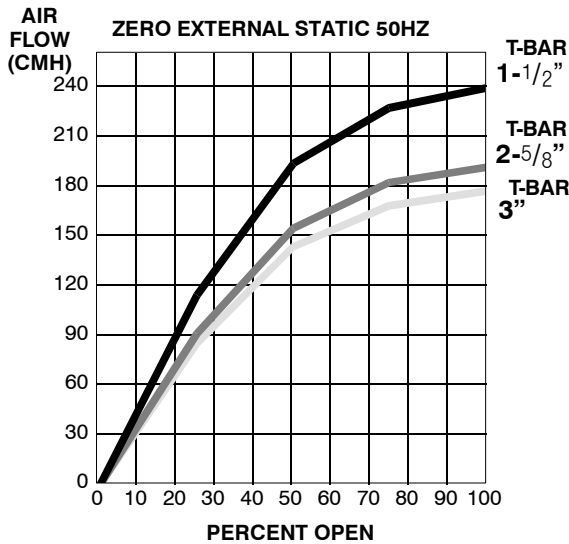

For 60Hz operation multiply curves by 1.2

Figure 4-2 Make Up Air Flow Chart

4.3.2 Fresh Air Position Sensor

The VPS allows the user to determine position of the fresh air vent via function code 45. This function code is accessible via the code select key.

The vent position will display for 30 seconds whenever motion corresponding to 5CMH (3CFM) or greater is detected. It will scroll in intervals of 5CMH (3CFM). Scrolling to Function Code 45 will display the Fresh Air Vent Position.

Data Recording of the Sensor Position – The position of the vent will be recorded in the DataCorder whenever the unit is running under AC power and any of the following:

- Trip start
- On every power cycle
- Midnight
- Manual change greater than 5CMH (3CFM) and remains in that position for four minutes

NOTE

The user has four minutes to make necessary adjustments to the vent setting. This time begins on the initial movement of the sensor. The vent can be moved to any position within the four minutes.

On completion of the first four minutes, the vent is required to remain stable for the next four minutes. If vent position changes are detected during the four minutes stability period, an alarm will be generated. This provides the user with the ability to change the vent setting without generating multiple events in the DataCorder.

4.4 CONNECT WATER-COOLED CONDENSER

The water-cooled condenser is used when cooling water is available and heating the surrounding air is objectionable, such as in a ship's hold. If water-cooled operation is desired, connect in accordance with the following:

- Connect the water supply line to the inlet side of condenser and the discharge line to the outlet side of the condenser (see Figure 2-5).
- Maintain a flow rate of 11 to 26 liters per minute (3 to 7 gallons per minute). The water pressure switch will open to de-energize the condenser fan relay. The condenser fan motor will stop until the water pressure switch closes.

NOTE

If controller configuration variable CNF48 is activated the condenser fan motor will activate if the HPS opens twice in less than seven minutes. Power cycling the unit resets the counter.

- To shift to air-cooled condenser operation, disconnect the water supply and the discharge line to the water-cooled condenser.

The refrigeration unit will shift to air-cooled condenser operation when the water pressure switch closes or if the controller configuration variable CNF48 is activated, the condenser fan motor will activate if the HPS opens twice in less than seven minutes. Power cycling the unit resets the count.

4.5 CONNECT REMOTE MONITORING RECEPTACLE

If remote monitoring is required, connect remote monitor plug at unit receptacle (see item 9, Figure 2-6). When the remote monitor plug is connected to the remote monitoring receptacle, the following remote circuits are energized:

CIRCUIT	FUNCTION
Sockets B to A	Energizes remote cool light
Sockets C to A	Energizes remote defrost light
Sockets D to A	Energizes remote in-range light

4.6 STARTING AND STOPPING INSTRUCTIONS



Make sure that the unit circuit breaker(s) (CB-1 & CB-2) and the START-STOP switch (ST) are in the “O” (OFF) position before connecting to any electrical power source.

4.6.1 Starting the Unit

1. With power properly applied, the fresh air damper set, and if required, the water-cooled condenser connected (refer to paragraphs 4.2, 4.3, & 4.4), place the START-STOP switch to “I” (ON).
2. Continue with Start Up Inspection (refer to paragraph 4.7).

4.6.2 Stopping the Unit

To stop the unit, place the START-STOP switch in position “O” (OFF).

4.7 START-UP INSPECTION

4.7.1 Physical Inspection

- a. Check rotation of condenser and evaporator fans.
- b. Check compressor oil level (refer to paragraph 6.8.6).

4.7.2 Check Controller Function Codes

Check and, if required, reset controller Function Codes (Cd27 through Cd39) in accordance with desired operating parameters (refer to paragraph 3.2.2).

4.7.3 Start Temperature Recorder

- a. Open recorder door and wind mechanical clock or check battery of electronic recorder. Be sure key is returned to storage clip of mechanical recorder.
- b. Lift stylus (pen) by pulling the marking tip outward until the stylus arm snaps into its retracted position.
- c. Install new chart making sure chart is under the four corner tabs. Lower the stylus until it has made contact with the chart. Close and secure door.

DataCORDER

- a. Check, and if required, set the DataCORDER Configuration in accordance with desired recording parameter (refer to paragraph 3.6.3).
- b. Enter a “Trip Start.” To enter a “Trip Start,” do the following:
 1. Depress the ALT MODE key and scroll to Code dC30.
 2. Depress and hold the ENTER key for five seconds.
 3. The “Trip Start” event will be entered in the DataCORDER.

4.7.4 Complete Inspection

Allow unit to run for five minutes to stabilize conditions and perform a pre-trip diagnosis in accordance with the following paragraph.

4.8 PRE-TRIP DIAGNOSIS



Pre-trip inspection should not be performed with critical temperature cargoes in the container.



When Pre-Trip key is pressed, dehumidification and bulb mode will be deactivated. At the completion of Pre-Trip activity, dehumidification and bulb mode must be reactivated.

Pre-Trip diagnosis provides automatic testing of the unit components using internal measurements and comparison logic. The program will provide a “PASS” or “FAIL” display to indicate test results.

The testing begins with access to a pre-trip selection menu. The user may have the option of selecting one of three automatic tests (depending on software revision installed).

These tests will automatically perform a series of individual pre-trip tests. The user may also scroll down to select any of the individual tests. The contents of the menus are as follows:

PRE-TRIP SELECTION MENU		
Auto or Auto 1	Auto 2	Auto 3
P1, P2, P3, P4, P5, P6, rSLts	P, P1, P2, P3, P4, P5, P6, P7, P8, P9, P10, rSLts	P, P1, P2, P3, P4, P5, P6, P7, P8, rSLts

A detailed description of the pre-trip test codes is listed in Table 3-7, page 3-22. If no selection is made, the pre-trip menu selection process will terminate automatically. However, dehumidification and bulb mode must be reactivated manually if required.

Scrolling down to the “rSLts” code and pressing ENTER will allow the user to scroll through the results of the last pre-trip testing run. If no pre-testing has been run (or an individual test has not been run) since the unit was powered up, “----” will be displayed.

To start a pre-trip test, do the following:

NOTE

1. Prior to starting tests, verify that unit voltage (Function Code Cd 07) is within tolerance and unit amperage draw (Function Codes Cd04, Cd05, Cd06) is within expected limits. Otherwise, tests may fail incorrectly.
2. All alarms must be rectified and cleared before starting tests.
- 3.. Pre-trip diagnosis may also be initiated via communications. The operation is the same as for the key pad initiation described below except that should a test fail, the pre-trip mode will automatically terminate. When initiated via communications, a test may not be interrupted with an arrow key, but the pre-trip mode can be terminated with the PRE-TRIP key.

- a. Press the PRE-TRIP key. This accesses a test selection menu.
- b. TO RUN AN AUTOMATIC TEST: Scroll through the selections by pressing the UP ARROW or DOWN ARROW keys to display AUTO, AUTO 2 or AUTO 3 as desired and then press the ENTER key.

- 1.The unit will execute the series of tests without any need for direct user interface. These tests vary in length, depending on the component under test.
- 2.While tests are running, “P#-#” will appear on the left display, where the #'s indicate the test number and sub-test. The right display will show a countdown time in minutes and seconds, indicating the amount of time remaining in the test.



When a failure occurs during automatic testing the unit will suspend operation awaiting operator intervention.

When an automatic test fails, it will be repeated once . A repeated test failure will cause “FAIL” to be shown on the right display, with the corresponding test number to the left.

The user may then press the DOWN ARROW to repeat the test, the UP ARROW to skip to the next test or the PRE-TRIP key to terminate testing. The unit will wait indefinitely until the user manually enters a command.



When Pre-Trip test Auto 2 runs to completion without being interrupted, the unit will terminate pre-trip and display “Auto 2” “end.” The unit will suspend operation until the user depresses the ENTER key!

When an Auto test runs to completion without a failure, the unit will exit the pre-trip mode and return to normal control operation. If configuration variable CnF42 is set to IN, a datacorder trip start will be entered. If CnF42 is set to OUT, the trip start will not be entered. However, dehumidification and bulb mode must be reactivated manually if required.

c. TO RUN AN INDIVIDUAL TEST: Scroll through the selections by pressing the UP ARROW or DOWN ARROW keys to display an individual test code. Pressing ENTER when the desired test code is displayed.

1. Individually selected tests, other than the LED/Display test, will perform the operations necessary to verify the operation of the component. At the conclusion, PASS or FAIL will be displayed.

This message will remain displayed for up to three minutes, during which time a user may select another test. If the three minute time period expires, the unit will terminate pre-trip and return to control mode operation.

2. While the tests are being executed, the user may terminate the pre-trip diagnostics by pressing and holding the PRE-TRIP key.

The unit will then resume normal operation. If the user decides to terminate a test but remain at the test selection menu, the user may press the UP ARROW key. When this is done all test outputs will be de-energized and the test selection menu will be displayed.

3. Throughout the duration of any pre-trip test except the P-7 high pressure switch tests, the current and pressure limiting processes are active.

d. Pre-Trip Test Results

At the end of the pre-trip test selection menu, the message "P," "rSLts" (pre-trip results) will be displayed. Pressing the ENTER key will allow the user to see the results for all subtests (i.e., 1-0, 1-1, etc).

The results will be displayed as "PASS" or "FAIL" for all the tests run to completion since power up. If a test has not been run since power up, "-----" will be displayed.

Once all pre-test activity is completed, dehumidification and bulb mode must be reactivated manually if required.

4.9 OBSERVE UNIT OPERATION

4.9.1 Crankcase Heater

When the crankcase heater is installed, it will be operational whenever the compressor is off and there is power to the unit. The heater is connected to a set of normally closed auxiliary contacts on the compressor contactor.

4.9.2 Probe Check

If the DataCORDER is off or in alarm mode, the controller will revert to a four probe configuration, which includes the DataCORDER supply and return air probes as the secondary controller probes. The controller continuously performs probe diagnosis testing, which compares the four probes. If the probe diagnosis result indicates a probe problem exists, the controller will perform a probe check to identify the probe(s) in error.

a. Probe Diagnostic Logic - Standard

If the probe check option (controller configuration code CnF31) is configured for standard, the criteria used for comparison between the primary and secondary **control** probes is:

1°C (1.8°F) for perishable set points or 2°C (3.6°F) for frozen set points.

If 25 or more of 30 readings taken within a 30-minute period are outside of the limit, then a defrost is initiated and a probe check is performed.

In this configuration, a probe check will be run as a part of every normal (time initiated) defrost.

b. Probe Diagnostic Logic - Special

If the probe check option is configured for special, the above criteria are applicable. A defrost with probe check will be initiated if 25 of 30 readings or 10 consecutive readings are outside of the limits

In this configuration, a probe check will not be run as a part of a normal defrost, but only as a part of a defrost initiated due to a diagnostic reading outside of the limits.

c. The 30-minute timer will be reset at each of the following conditions:

- At every power up
- At the end of every defrost
- After every diagnostic check that does not fall outside of the limits as outlined above.

d. Probe Check:

A defrost cycle probe check is accomplished by energizing just the evaporator motors for eight minutes at the end of the normal defrost. At the end of the eight minute period, the probes will be compared to a set of predetermined limits. The defrost indicator will remain on throughout this period.

Any probe(s) determined to be outside the limits will cause the appropriate alarm code(s) to be displayed to identify the probe(s) that needs to be replaced. The P5 Pre-Trip test must be run to inactivate alarms.

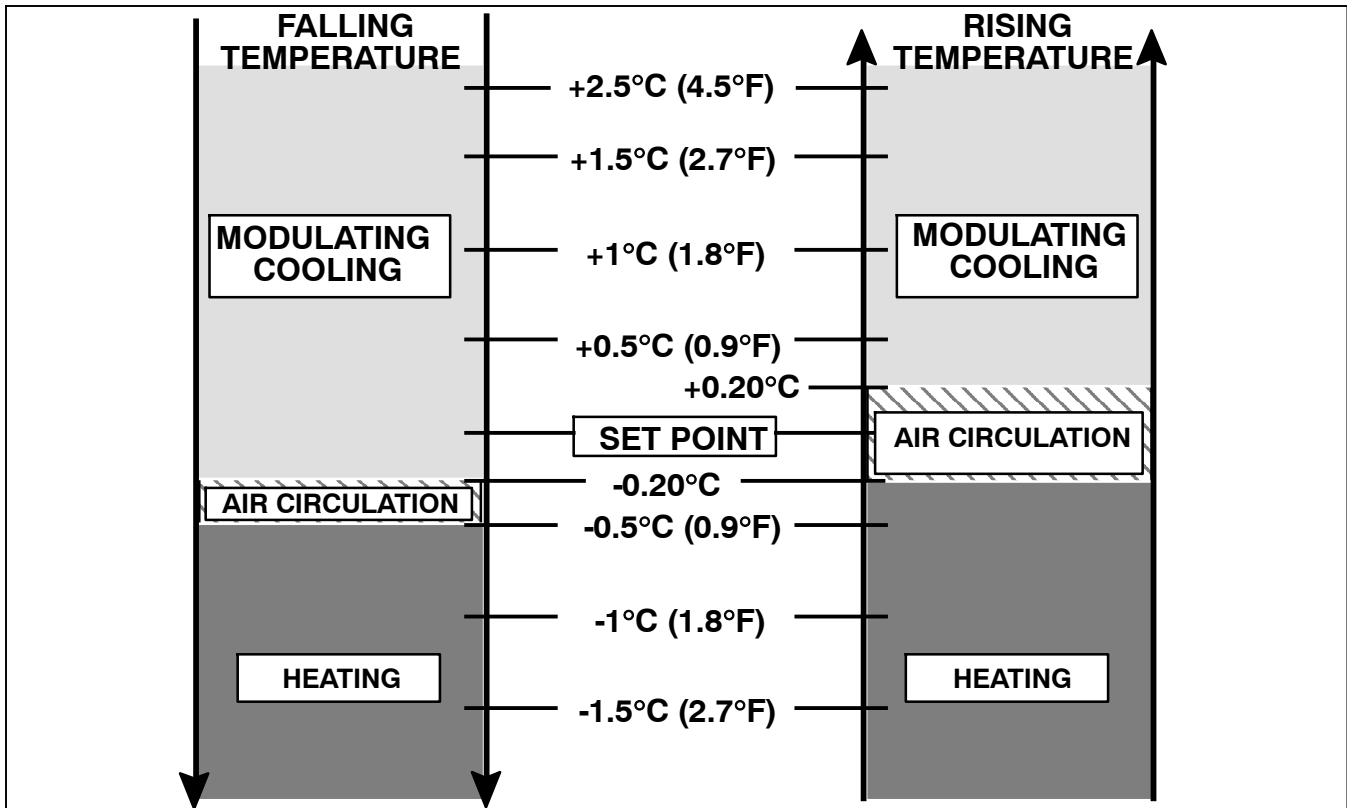

Figure 4-3 Controller Operation - Perishable Mode

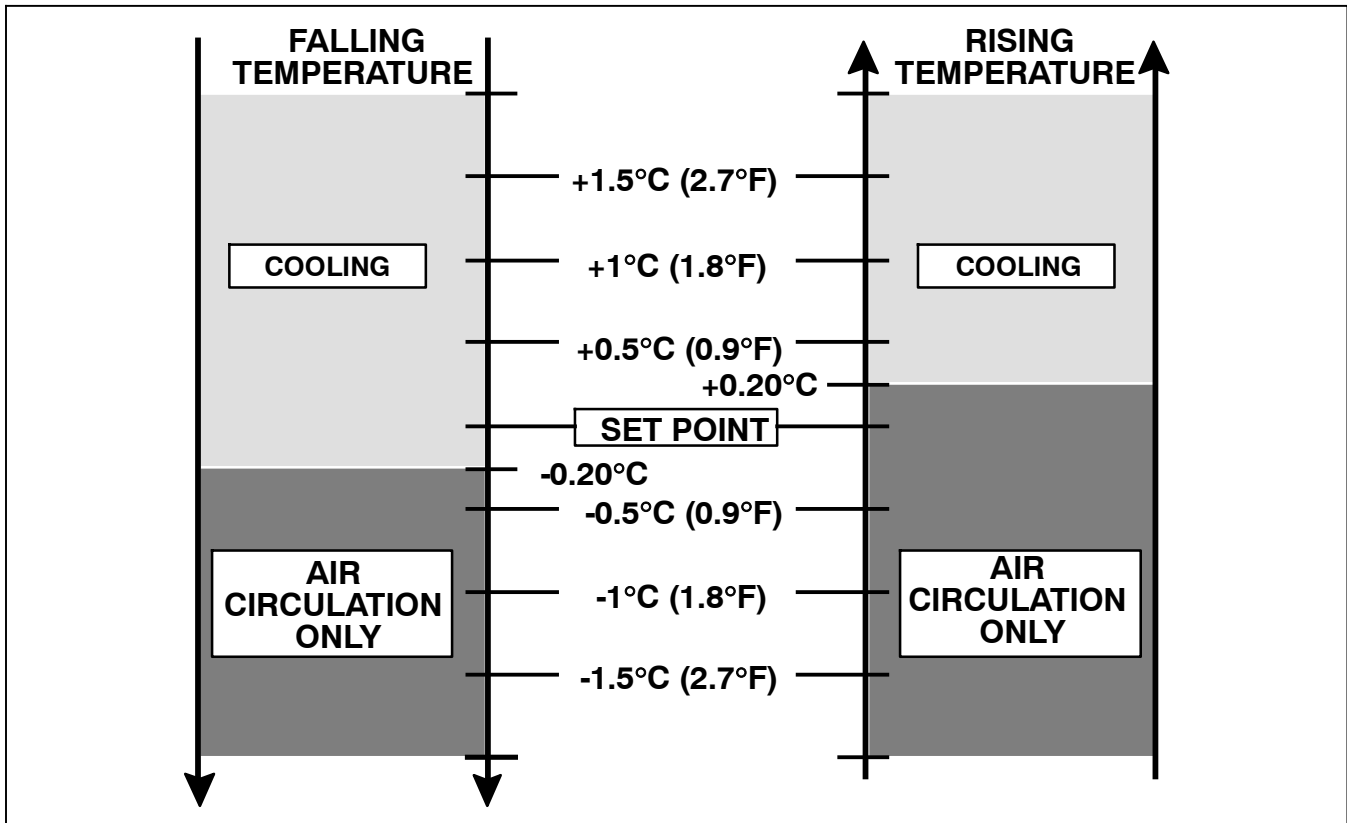

Figure 4-4 Controller Operation - Frozen Mode

4.10 SEQUENCE OF OPERATION

General operation sequences for cooling, heating, and defrost are provided in the following subparagraphs. Schematic representation of controller action are provided in Figure 4-3 and Figure 4-4. Refer to Section 3 for detailed descriptions of special events and timers that are incorporated by the controller in specific modes of operation.

4.10.1 Sequence of Operation - Perishable Mode Cooling

NOTE

In the conventional Perishable Mode of Operation, the evaporator motors run in high speed. In the economy Perishable Mode, the fan speed is varied.

NOTE

In low temperature ambients, the condenser fan will be cycled by the controller to maintain proper condensing pressure.

- a. With supply air temperature above set point and decreasing, the unit will be cooling with the condenser fan motor (CF), compressor motor (CH), evaporator fan motors (EF) energized, and the COOL light illuminated (see Figure 4-5).

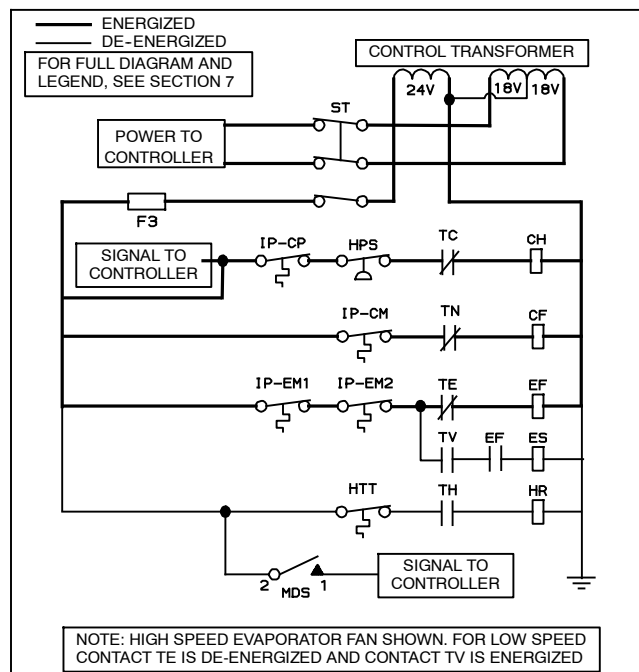

Figure 4-5 Perishable Mode Cooling

- b. When the air temperature decreases to a predetermined tolerance above set point, the in-range light is illuminated.
- c. As the air temperature continues to fall, modulating cooling starts at approximately 2.5°C (4.5°F) above set point (see Figure 4-3).
- d. The controller monitors the supply air. Once the supply air falls below set point and 0% SMV position is reached, the controller periodically records the supply air temperature, set point, and time. A calculation is then performed by subtracting the set point reading

from the supply air and multiplying the result by the time reading. The result is negative number.

- e. When the calculation reaches -250, contacts TC and TN are opened to de-energize compressor and condenser fan motors. The cool light is also de-energized.
- f. The evaporator fan motors continue to run to circulate air throughout the container. The in-range light remains illuminated as long as the supply air is within tolerance of set point.
- g. When the supply air temperature increases to 0.2°C (0.4°F) above set point and the three minute off time has elapsed, relays TC and TN are energized to restart the compressor and condenser fan motors. The cool light is also illuminated.

4.10.2 Sequence of Operation - Perishable Mode Heating

NOTE

The unit will heat only when in the Perishable Mode, relay TH is electronically locked out when in the Frozen Mode.

- a. If the air temperature decreases 0.5°C (0.9°F) below set point, the system enters the heating mode (see Figure 4-3). The controller closes contacts TH (see Figure 4-6) to allow power flow through the heat termination thermostat (HTT) to energize the heaters (HR). The HEAT light is also illuminated. The evaporator fans continue to run to circulate air throughout the container.
- b. When the temperature rises to 0.2°C (0.4°F) below set point, contact TH opens to de-energize the heaters. The HEAT light is also de-energized. The evaporator fans continue to run to circulate air throughout the container.
- c. A safety heater termination thermostat (HTT), attached to an evaporator coil support, will open the heating circuit if overheating occurs.

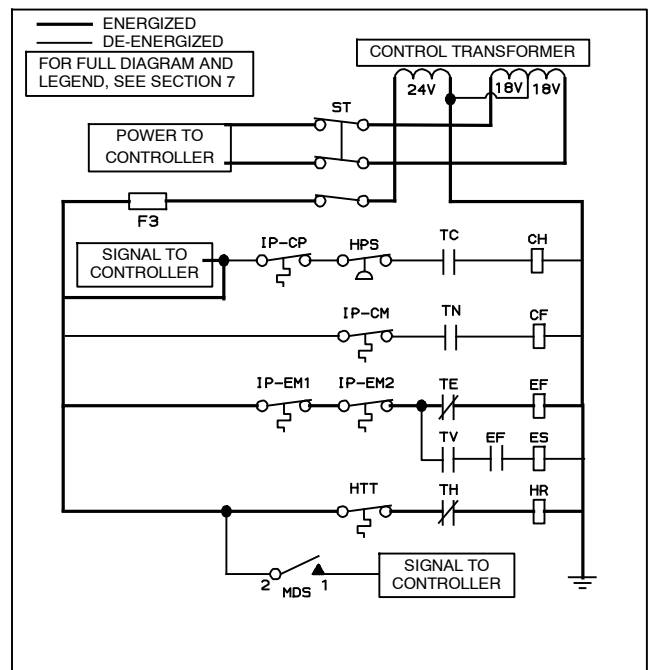

Figure 4-6 Perishable Mode Heating

4.10.3 Sequence of Operation - Frozen Mode Cooling

NOTES

- 1.. In the Frozen Mode of operation the evaporator motors run in low speed.
 - 2.. In low temperature ambients, the condenser fan will be cycled by the controller to maintain proper condensing pressure.
- a. With supply air temperature above set point and decreasing, the unit will be cooling with the condenser fan motor (CF), compressor motor (CH), evaporator fan motors (ES) energized and the COOL light illuminated (see Figure 4-7).
 - b. When the air temperature decreases to a predetermined tolerance above set point, the in-range light is illuminated.

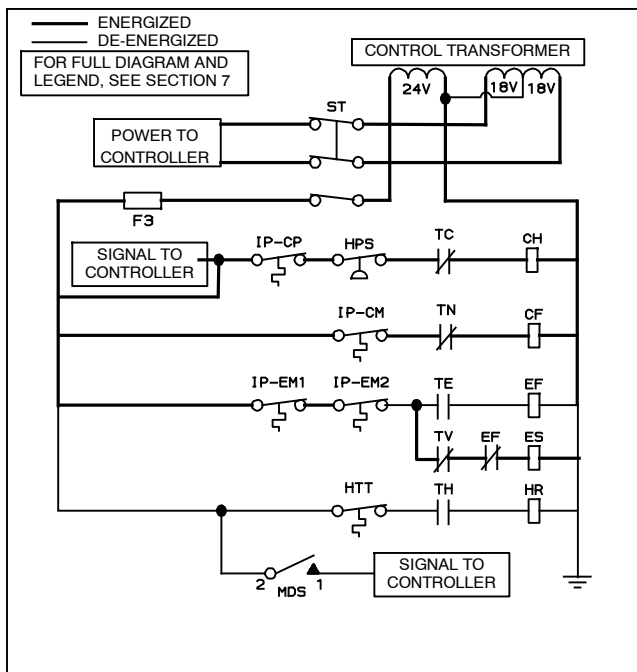

Figure 4-7 Frozen Mode

- c. Contacts TC and TN are opened to de-energize the compressor and condenser fan motors when the return air temperature decreases to 0.2°C (0.4°F) below set point. The cool light is also de-energized.
- d. The evaporator fan motors continue to run to circulate air throughout the container. The in-range light remains illuminated as long as the return air is within tolerance of set point.
- e. When the return air temperature increases to 0.2°C (0.4°F) above set point and the three minute off time has elapsed, relays TC and TN are energized to restart the compressor and condenser fan motors. The cool light is also illuminated.

4.10.4 Sequence of Operation - Defrost

The defrost cycle may consist of up to three distinct operations. The first is de-icing of the coil, the second is a probe check cycle, and the third is snap freeze.

Defrost may be requested by any one of the following methods:

The manual defrost function (also manual defrost switch function if equipped) is initiated and ended by the user using the keypad or manual defrost switch (if equipped).

NOTE

The Manual Defrost / Interval key can be used to initiate a manual defrost. Minimum Software release version #5126 is required in order to use this function.

Manual Defrost/Interval Key Operation:

1. Depressing and holding the Manual Defrost/Interval Key for five seconds will initiate defrost. If the Manual Defrost/Interval Key is released in less than five seconds, defrost interval (code 27) shall be displayed.
2. The user sends a defrost request by communications.
3. The defrost interval timer (controller function code Cd27) reaches the defrost interval set by the user.
4. The controller probe diagnostic logic determines that a probe check is necessary based on the temperature values currently reported by the supply and return probes.
5. The controller Demand Defrost configuration variable (CnF40) is set to "In" and the unit has been in pull down operation for over 2.5 hours without reaching set point.

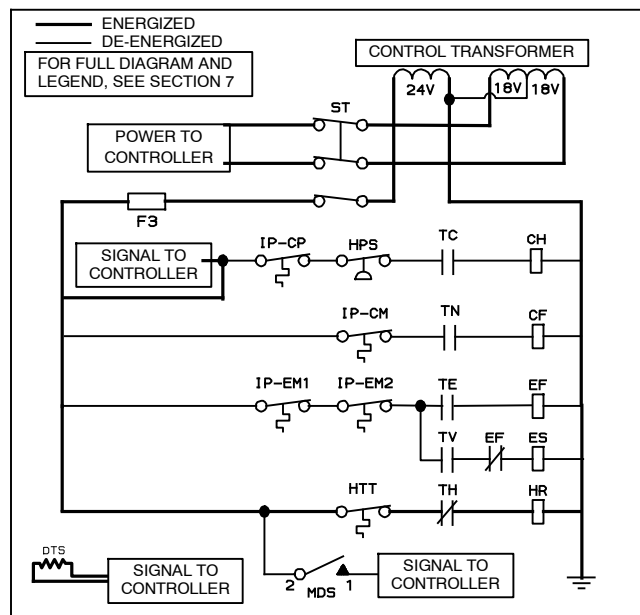

Figure 4-8 Defrost

The processing of a defrost request is controlled by the defrost termination thermostat. The defrost termination thermostat is not a physical component. It is a software point that acts as a thermostat, allowing defrost when it is considered “closed” and preventing or terminating defrost when it is considered “open.”

The actual temperatures used to make the “open” or “closed” determinations are dependent on the type of defrost request made and the operator setting of configuration variable CnF41. Configuration variable CnF41 may be factory set at the default value of 25.6°C (78°F) or a lower value of 18°C (64°F).

When a request for defrost is made by the use of the Manual Defrost Switch or Communications, the unit will enter defrost when the reading at the defrost temperature sensor is at or below the CnF41 setting. Defrost will terminate when the defrost sensor temperature reading rises above the CnF41 setting.

When a request for defrost is made by probe check, the unit will enter defrost when the defrost temperature sensor reading is at or below 25.6°C (78°F). The unit will terminate defrost when the Defrost Temperature Sensor reading rises above 25.6°C (78°F)

When a request for defrost is made by demand defrost, the unit will enter defrost when the reading at the defrost temperature sensor is at or below 18°C (64.4°F). Defrost will terminate when the defrost sensor temperature reading rises above the CnF41 setting.

When a defrost has terminated, the defrost interval timer will begin counting when the reading at the defrost temperature sensor is at or below 10°C (50°F). Once the timer has counted the required time, the unit will enter defrost if the Defrost Temperature Sensor is at or below 25.6°C (78°F). Defrost will terminate when the defrost sensor temperature reading rises above the CnF41 setting.

When the unit enters defrost, the controller opens contacts TC, TN, and TE (or TV) to de-energize the compressor, condenser fan and evaporator fans (see Figure 4-8). The COOL light is also de-energized.

The controller then closes TH to supply power to the heaters. The defrost light is illuminated.

When the defrost temperature sensor reading rises to the applicable defrost termination thermostat “opening” point, the de-icing operation is terminated.

If defrost does not terminate correctly and temperature reaches the set point of the heat termination thermostat (HTT), the thermostat will open to de-energize the heaters. If termination does not occur within two hours, the controller will terminate defrost. An alarm will be given of a possible DTS failure.

If probe check (controller function code CnF31) is configured to special, the unit will proceed to the next operation (snap freeze or terminate defrost). If the code is configured to standard, the unit will perform a probe check. The purpose of the probe check is to detect malfunctions or drift in the sensed temperature that is too small to be detected by the normal sensor out of range tests. The system will run for eight minutes in this condition. At the end of the eight minutes, probe alarms will be set or cleared based on the conditions seen.

4.11 EMERGENCY OPERATION (OPTION)

Operation by the refrigeration controller may be overridden by use of the EMERGENCY BYPASS or by use of the EMERGENCY DEFROST switch. The EMERGENCY BYPASS switch functions to bypass the controller in the event of controller failure. The EMERGENCY DEFROST switch functions to bypass the controller and place the unit in the defrost mode.

4.11.1 Emergency Bypass Operation

To place the unit in the emergency bypass mode, cut the wire tie installed at the switch mounting and place the EMERGENCY BYPASS switch in the BYPASS position. This will in turn activate the Emergency Bypass System (EBS) control module.

To operate the fans only, the MODE switch must be in the FANS ONLY position and the EMERGENCY BYPASS Switch must be in the ON position.

The EBS module uses the system’s safety devices (high pressure switch, motor internal protectors, and heat termination thermostat) to protect the system while in Emergency Bypass Mode.



The unit will remain in the full cooling mode as long as the emergency bypass switch is in the BYPASS position and the MODE SWITCH is in the FULL COOL position.

If the cargo may be damaged by low temperatures, the operator must monitor container temperature and manually cycle operation as required to maintain temperature within required limits.

In the ON position the EBS will be enabled. With the MODE SWITCH in the FULL COOL MODE. The following will occur simultaneously:

1. The EBS switch will enable EBS input.
2. The phase detection circuit will detect the phase rotation and close to provide power to the compressor contactor.
3. The condenser fan contact will close to energize the condenser contactor and provide power to the condenser fan motor.
4. The evaporator fan contact will close to energize the high speed evaporator contactor and provide power to the evaporator fan motor.
5. The EBS electronic module will open the SMV to 100%.

To return the unit to normal operation, place the EBS switch in the NORMAL OPERATION position. When emergency operation is no longer required, re-install the wire tie at the switch mounting.

4.11.2 Emergency Defrost Operation

To place the unit in the emergency defrost mode of operation, cut the wire tie installed at the switch mounting (see Figure 2-6) and place the switch in the EMERGENCY DEFROST position.

NOTE

1. If the unit is in the emergency bypass cooling mode, the emergency defrost switch will override this mode and place the unit in defrost.
2. The IN-RANGE LIGHT is de-energized when in the emergency defrost mode.

The switch is a normally open four-pole switch, which is placed in the EMERGENCY DEFROST position to:

- a. De-energize the compressor, condenser fan and evaporator fan contactors.
- b. Illuminate the EMERGENCY DEFROST LIGHT.
- c. Energize the heater contactor.
- d. Illuminate the DEFROST LIGHT.



CAUTION

The unit will remain in the DEFROST mode as long as the emergency defrost switch is in the DEFROST position. To prevent cargo damage, the operator must monitor container temperature and manually cycle operation as required to maintain temperature within required limits.

To return the unit to normal operation, place the switch in the NORMAL OPERATION position. When emergency defrost is no longer required, re-install the wire tie at the switch mounting.

4.12 ARCTIC MODE

With arctic mode enabled, if the ambient is colder than -10.0°C there is a 30-minute time delay at startup for any of the components in the system, except for the controller and the compressor crankcase heater (CCH), which should be active at this point.

In arctic mode, the CCH is energized for 30 minutes to warm the oil in the compressor and boil off any liquid refrigerant that may be present in the crankcase.

If Pre-Trip is initiated during the 30-minute time period, Pre-Trip will be allowed to run normally. Once Pre-Trip is over, the controller will revert to its normal control mode logic.

If ambient is warmer than -10.0°C (14°F), the system will run its normal startup logic.

Arctic mode is configurable by using the configuration variable #29, refer to Table 3-4.

SECTION 5 TROUBLESHOOTING

CONDITION	POSSIBLE CAUSE	REMEDY/ REFERENCE SECTION
5.1 UNIT WILL NOT START OR STARTS THEN STOPS		
No power to unit	External power source OFF	Turn on
	Start-Stop switch OFF or defective	Check
	Circuit breaker tripped or OFF	Check
	Autotransformer not connected	4.2.2
Loss of control power	Circuit breaker OFF or defective	Check
	Control transformer defective	Replace
	Fuses (F3A , F3B) blown	Check
	Start-Stop switch OFF or defective	Check
Component(s) Not Operating	Evaporator fan motor internal protector open	6.16
	Condenser fan motor internal protector open	6.11
	Compressor internal protector open	6.8
	High pressure switch open	5.7
	Heat termination thermostat open	Replace
Compressor hums, but does not start	Low line voltage	Check
	Single phasing	Check
	Shorted or grounded motor windings	6.8
	Compressor seized	6.8
5.2 UNIT OPERATES LONG OR CONTINUOUSLY IN COOLING		
Container	Hot load (Failure to Pre-cool)	Normal
	Defective box insulation or air leak	Repair
Refrigeration System	Shortage of refrigerant	6.7.1
	Evaporator coil covered with ice	5.6
	Evaporator coil plugged with debris	6.15
	Evaporator fan(s) rotating backwards	6.15/6.16
	Defective evaporator fan motor/capacitor	6.17
	Air bypass around evaporator coil	Check
	Controller set too low	Reset
	Compressor service valves or liquid line shutoff valve partially closed	Open valves completely
	Dirty condenser	6.10
	Compressor worn	6.8
	Current limit (function code Cd32) set to wrong value	3.3.5
Suction modulation valve malfunction	6.19	

CONDITION	POSSIBLE CAUSE	REMEDY/ REFERENCE SECTION
5.3 UNIT RUNS BUT HAS INSUFFICIENT COOLING		
Compressor	Compressor valves defective	6.8
Refrigeration System	Abnormal pressures	5.7
	Controller malfunction	5.9
	Evaporator fan or motor defective	6.16
	Suction modulation valve malfunction	6.19
	Condenser Pressure Transducer defective	Check
	Shortage of refrigerant	6.7.1
5.4 UNIT WILL NOT HEAT OR HAS INSUFFICIENT HEATING		
No operation of any kind	Start-Stop switch OFF or defective	Check
	Circuit breaker OFF or defective	Check
	External power source OFF	Turn ON
No control power	Circuit breaker or fuse defective	Replace
	Control Transformer defective	Replace
	Evaporator fan internal motor protector open	6.16
	Heat relay defective	Check
	Heater termination switch open	6.15
Unit will not heat or has insufficient heat	Heater(s) defective	6.15
	Heater contactor or coil defective	Replace
	Evaporator fan motor(s) defective or rotating backwards	6.15/6.16
	Evaporator fan motor contactor defective	Replace
	Controller malfunction	5.9
	Defective wiring	Replace
	Loose terminal connections	Tighten
Low line voltage	2.3	
5.5 UNIT WILL NOT TERMINATE HEATING		
Unit fails to stop heating	Controller improperly set	Reset
	Controller malfunction	5.9
	Heater termination thermostat remains closed along with the heat relay	6.15
5.6 UNIT WILL NOT DEFROST PROPERLY		
Will not initiate defrost automatically	Defrost timer malfunction (Cd27)	Table 3-5
	Loose terminal connections	Tighten/
	Defective wiring	Replace
	Defrost temperature sensor defective or heat termination thermostat open	Replace
	Heater contactor or coil defective	Replace
Will not initiate defrost manually	Manual defrost switch defective	Replace
	Defrost temperature sensor open	4.10.4
Initiates but relay (DR) drops out	Low line voltage	2.3
Initiates but does not defrost	Heater contactor or coil defective	Replace
	Heater(s) burned out	6.15

CONDITION	POSSIBLE CAUSE	REMEDY/ REFERENCE SECTION
5.6 UNIT WILL NOT DEFROST PROPERLY -Continued		
Frequent defrost	Wet load	Normal
5.7 ABNORMAL PRESSURES (COOLING)		
High discharge pressure	Condenser coil dirty	6.10
	Condenser fan rotating backwards	6.11
	Condenser fan inoperative	6.11
	Refrigerant overcharge or noncondensibles	6.7.1
	Discharge pressure regulator valve defective	6.20
	Discharge service valve partially closed	Open
	Suction modulation valve malfunction	6.19
Low suction pressure	Suction service valve partially closed	Open
	Filter-drier partially plugged	6.13
	Low refrigerant charge	6.7.1
	Expansion valve defective	6.14
	No evaporator air flow or restricted air flow	6.15
	Excessive frost on evaporator coil	5.6
	Evaporator fan(s) rotating backwards	6.16
	Discharge pressure regulator valve defective	6.20
Suction modulation valve malfunction	6.19	
Suction and discharge pressures tend to equalize when unit is operating	Heat exchanger defective	Replace
	Compressor valves defective	6.8
	Compressor cycling/stopped	Check
5.8 ABNORMAL NOISE OR VIBRATIONS		
Compressor	Loose mounting bolts	Tighten
	Worn bearings	6.8
	Worn or broken valves	6.8
	Liquid slugging	6.14
	Insufficient oil	6.8.6
Condenser or Evaporator Fan	Bent, loose or striking venturi	Check
	Worn motor bearings	6.11/6.16
	Bent motor shaft	6.11/6.16
5.9 CONTROLLER MALFUNCTION		
Will not control	Defective Sensor	6.23
	Defective wiring	Check
	Fuse (F1, F2) blown	Replace
	Stepper motor suction modulation valve circuit malfunction	6.19

CONDITION	POSSIBLE CAUSE	REMEDY/ REFERENCE SECTION
5.10 NO EVAPORATOR AIR FLOW OR RESTRICTED AIR FLOW		
Evaporator coil blocked	Frost on coil	5.6
	Dirty coil	6.15
No or partial evaporator air flow	Evaporator fan motor internal protector open	6.16
	Evaporator fan motor(s) defective	6.16
	Evaporator fan(s) loose or defective	6.16
	Evaporator fan contactor defective	Replace
5.11 THERMOSTATIC EXPANSION VALVE MALFUNCTION		
Low suction pressure with high superheat	Low refrigerant charge	6.7.1
	External equalizer line plugged	Open
	Wax, oil or dirt plugging valve or orifice ice formation at valve seat	6.14
	Superheat too high	6.7.1
	Power assembly failure	6.14
	Loss of element/bulb charge	
	Broken capillary	
	Foreign material in valve	
High suction pressure with low superheat	Superheat setting too low	6.14
	External equalizer line plugged ice holding valve open	Open
	Foreign material in valve	6.14
Liquid slugging in compressor	Pin and seat of expansion valve eroded or held open by foreign material	6.14
Fluctuating suction pressure	Improper bulb location or installation	
	Low superheat setting	
5.12 AUTOTRANSFORMER MALFUNCTION		
Unit will not start	Circuit breaker (CB-1 or CB-2) tripped	Check
	Autotransformer defective	6.21
	Power source not turned ON	Check
	460 VAC power plug is not inserted into the receptacle	4.2.2
5.13 WATER-COOLED CONDENSER OR WATER PRESSURE SWITCH		
High discharge pressure	Dirty coil	6.12
	Noncondensibles	
Condenser fan starts and stops	Water pressure switch malfunction	Check
	Water supply interruption	Check

SECTION 6

SERVICE

NOTE

To avoid damage to the earth's ozone layer, use a refrigerant recovery system whenever removing refrigerant. When working with refrigerants, you must comply with all local government environmental laws. In the U.S., refer to EPA section 608.



WARNING

Never use air for leak testing. It has been determined that pressurized mixtures of refrigerant and air can undergo combustion when exposed to an ignition source.

6.1 SECTION LAYOUT

Service procedures are provided herein beginning with refrigeration system service, then refrigeration system component service, electrical system service, temperature recorder service, and general service. Refer to the Table Of Contents to locate specific topics.

6.2 SERVICE VALVES

The compressor suction, compressor discharge, and liquid line service valves (see Figure 6-1) are provided with a double seat and a gauge connection, which enables servicing of the compressor and refrigerant lines. Turning the valve stem clockwise (all the way forward) will frontseat the valve to close off the suction, discharge or liquid line and open the gauge port to the compressor or low side. Turning the valve stem counterclockwise (all the way out) will backseat the valve to open the connections and close off the port.

With the valve stem midway between frontseat and backseat, the lines are open to both the connections and the gauge connection.

For example, the valve stem is first fully backseated when connecting a manifold gauge to measure pressure. Then, the valve is opened 1/4- to 1/2-turn to measure the pressure.

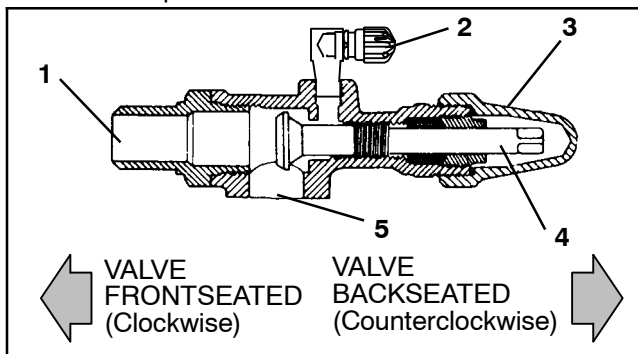

- | | |
|---|---|
| 1. Suction, Discharge or
Liquid Line
Connection | 3. Stem Cap |
| 2. Service Port | 4. Valve stem |
| | 5. Compressor Or Filter
Drier Inlet Connection |

Figure 6-1 Service Valve

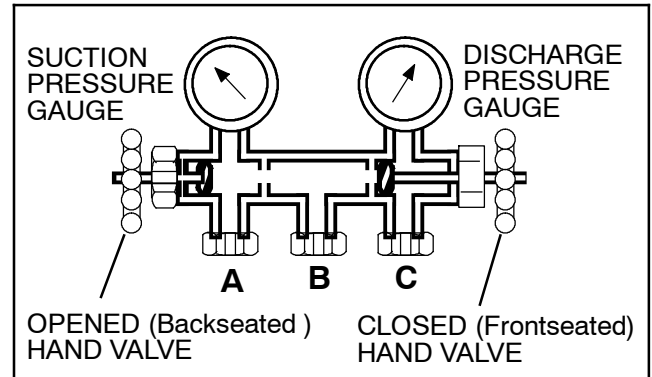

- A. Connection to Low Side of System
- B. Connection to either:
Refrigerant Cylinder or
Oil Container
- C. Connection to High Side of System

Figure 6-2 Manifold Gauge Set

6.3 MANIFOLD GAUGE SET

The manifold gauge set (see Figure 6-2) is used to determine system operating pressure, add refrigerant charge, and to equalize or evacuate the system.

When the suction pressure hand valve is frontseated (turned all the way in), the suction (low) pressure can be checked. When the discharge pressure hand valve is frontseated, the discharge (high) pressure can be checked. When both valves are open (turned counter-clockwise all the way out), high pressure vapor will flow into the low side. When the suction pressure valve is open and the discharge pressure valve shut, the system can be charged. Oil can also be added to the system.

A R-134a manifold gauge/hose set with self-sealing hoses (see Figure 6-3) is required for service of the models covered within this manual. The manifold gauge/hose set is available from Carrier Transicold. (Carrier Transicold P/N 07-00294-00, which includes items 1 through 6, Figure 6-3). To perform service using the manifold gauge/hose set, do the following:

a. Preparing Manifold Gauge/Hose Set For Use

If the manifold gauge/hose set is new or was exposed to the atmosphere, it will need to be evacuated to remove contaminants and air as follows:

1. Back seat (turn counterclockwise) both field service couplings (see Figure 6-3) and midseat both hand valves.
2. Connect the yellow hose to a vacuum pump and refrigerant 134a cylinder.
3. Evacuate to 10 inches of vacuum and then charge with R-134a to a slightly positive pressure of 0.1kg/cm² (1.0psig).

4. Front seat both manifold gauge set valves and disconnect from cylinder. The gauge set is now ready for use.

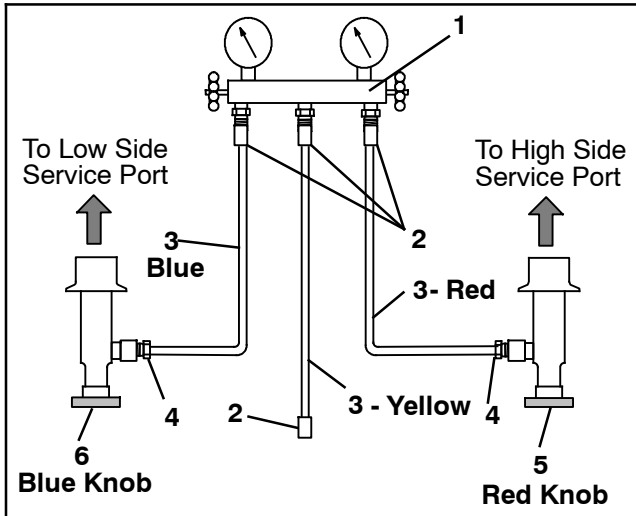

1. Manifold Gauge Set
2. Hose Fitting (0.5-16 Acme)
3. Refrigeration and/or Evacuation Hose (SAE J2196/R-134a)
4. Hose Fitting w/O-ring (M14 x 1.5)
5. High Side Field Service Coupling
6. Low Side Field Service Coupling

Figure 6-3 R-134a Manifold Gauge/Hose Set

b. Connecting Manifold Gauge/Hose Set

Connection of the manifold gauge/hose set (see Figure 6-4) is dependent on the component being serviced. If only the compressor is being serviced, the high side coupling is connected to the discharge service valve. For service of the low side (after pump down), the high side coupling is connected to the liquid line service valve. The center hose connection is brought to the tool being used. To connect the manifold gauge/hose set, do the following:

1. Remove service valve stem caps and check to make sure they are backseated. Remove service port caps (See Figure 6-1).
2. Connect the high side field service coupling (see Figure 6-3) to the discharge or liquid line service valve port.
3. Turn the high side field service coupling knob (red) clockwise, which will open the high side of the system to the gauge set.
4. Connect the low side field service coupling to the suction service valve port.
5. Turn the low side field service coupling knob (blue) clockwise, which will open the low side of the system to the gauge set.
6. To read system pressures, slightly midseat the high side and suction service valves.

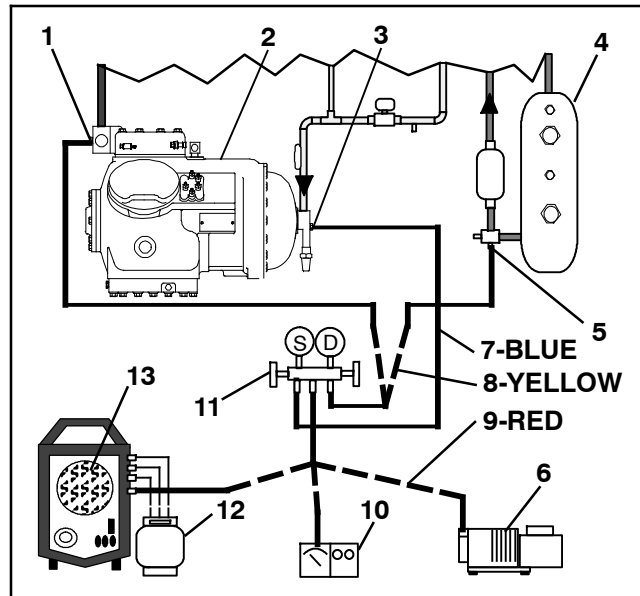

- | | |
|---------------------------------------|-----------------------------|
| 1. Discharge Service Valve | 7. Low Side Hose |
| 2. Compressor | 8. Center Hose |
| 3. Suction Service Valve | 9. High Side Hose |
| 4. Receiver or Water Cooled Condenser | 10. Electronic Vacuum Gauge |
| 5. Liquid Service Valve | 11. Manifold Gauge Set |
| 6. Vacuum Pump | 12. Refrigerant Cylinder |
| | 13. Reclaimer |

Figure 6-4 Refrigeration System Service Connections

CAUTION

To prevent trapping liquid refrigerant in the manifold gauge set, be sure set is brought to suction pressure before disconnecting.

c. Removing the Manifold Gauge Set

1. While the compressor is still ON, backseat the high side service valve.
2. Midseat both hand valves on the manifold gauge set and allow the pressure in the manifold gauge set to be drawn down to suction pressure. This returns any liquid that may be in the high side hose to the system.
3. Backseat the suction service valve. Backseat both field service couplings and frontseat both manifold set valves. Remove the couplings from the service ports.
4. Install both service valve stem caps and service port caps (finger-tight only).

6.4 PUMPING THE UNIT DOWN

To service the filter-drier, moisture-liquid indicator, expansion valve, suction modulation valve, quench valve, or evaporator coil, pump the refrigerant into the high side as follows:

- a. Attach manifold gauge set to compressor service valves (refer to paragraph 6.3).
- b. Start the unit and run in a cooling mode for 10 to 15 minutes. Frontseat the liquid line service valve. Place start-stop switch in the OFF position when the suction reaches a positive pressure of 0.1kg/cm² (1.0psig).
- c. Frontseat the suction service valve. The refrigerant will be trapped between the compressor suction service valve and the liquid line valve.
- d. Before opening up any part of the system, a slight positive pressure should be indicated on the pressure gauge. If a vacuum is indicated, emit refrigerant by cracking the liquid line valve momentarily to build up a slight positive pressure.
- e. When opening up the refrigerant system, certain parts may frost. Allow the part to warm to ambient temperature before dismantling. This avoids internal condensation, which puts moisture in the system.
- f. After repairs have been made, be sure to perform a refrigerant leak check (refer to paragraph 6.5), and evacuate and dehydrate the low side (refer to paragraph 6.6).
- g. Check refrigerant charge (refer to paragraph 6.7).

6.5 REFRIGERANT LEAK CHECKING



Never use air for leak testing. It has been determined that pressurized, air-rich mixtures of refrigerants and air can undergo combustion when exposed to an ignition source.

- a. The recommended procedure for finding leaks in a system is with a R-134a electronic leak detector. Testing joints with soapsuds is satisfactory only for locating large leaks.
- b. If the system is without refrigerant, charge the system with refrigerant 134a to build up pressure between 2.1 to 3.5kg/cm² (30 to 50psig). Remove refrigerant cylinder and leak-check all connections.

NOTE

Only refrigerant 134a should be used to pressurize the system. Any other gas or vapor will contaminate the system, which will require additional purging and evacuation of the system.

- c. If required, remove refrigerant using a refrigerant recovery system and repair any leaks.
- d. Evacuate and dehydrate the unit (refer to paragraph 6.6).
- e. Charge unit per paragraph 6.7.

6.6 EVACUATION AND DEHYDRATION

6.6.1 General

Moisture is the deadly enemy of refrigeration systems. The presence of moisture in a refrigeration system can have many undesirable effects. The most common are copper plating, acid sludge formation, "freezing-up" of metering devices by free water, and formation of acids, resulting in metal corrosion.

6.6.2 Preparation

- a. Evacuate and dehydrate only after pressure leak test (refer to paragraph 6.5).
- b. Essential tools to properly evacuate and dehydrate any system include a vacuum pump (8m³/hr = 5cfm volume displacement) and an electronic vacuum gauge. The pump is available from Carrier Transicold (P/N 07-00176-11).
- c. If possible, keep the ambient temperature above 15.6°C (60°F) to speed evaporation of moisture. If the ambient temperature is lower than 15.6°C (60°F), ice might form before moisture removal is complete. Heat lamps or alternate sources of heat may be used to raise the system temperature.
- d. Additional time may be saved during a complete system pump down by replacing the filter-drier with a section of copper tubing and the appropriate fittings. Installation of a new drier may be performed during the charging procedure.

6.6.3 Procedure - Complete System

- a. Remove all refrigerant using a refrigerant recovery system.
- b. The recommended method to evacuate and dehydrate the system is to connect three evacuation hoses (see Figure 6-5) to the vacuum pump and refrigeration unit. Be sure the service hoses are suited for evacuation purposes.
- c. Test the evacuation setup for leaks by backseating the unit service valves and drawing a deep vacuum with the vacuum pump and gauge valves open. Shut off the pump and check to see if the vacuum holds. Repair leaks if necessary.
- d. Midseat the refrigerant system service valves.
- e. Open the vacuum pump and electronic vacuum gauge valves, if they are not already open. Start the vacuum pump. Evacuate unit until the electronic vacuum gauge indicates 2000 microns. Close the electronic vacuum gauge and vacuum pump valves. Shut off the vacuum pump. Wait a few minutes to be sure the vacuum holds.
- f. Break the vacuum with clean dry refrigerant 134a gas. Raise system pressure to approximately 0.2kg/cm² (2psig), monitoring it with the compound gauge.
- g. Remove refrigerant using a refrigerant recovery system.
- h. Repeat steps e. and f. one time.

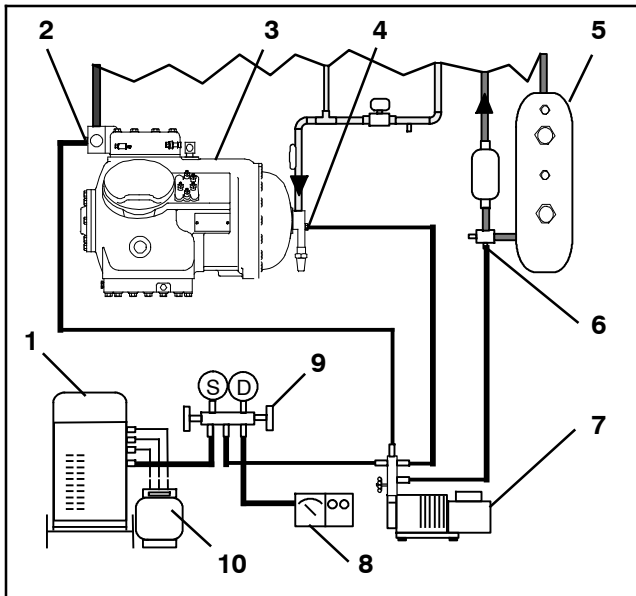

- | | |
|---------------------------------------|----------------------------|
| 1. Reclaimer | 6. Liquid Service Valve |
| 2. Discharge Service Valve | 7. Vacuum Pump |
| 3. Compressor | 8. Electronic Vacuum Gauge |
| 4. Suction Service Valve | 9. Manifold Gauge Set |
| 5. Receiver or Water Cooled Condenser | 10. Refrigerant Cylinder |

Figure 6-5 Compressor Service Connections

- i. Remove the copper tubing and change the filter-drier. Evacuate unit to 500 microns. Close the electronic vacuum gauge and vacuum pump valves. Shut off the vacuum pump. Wait five minutes to see if vacuum holds. This procedure checks for residual moisture and/or leaks.
- j. With a vacuum still in the unit, the refrigerant charge may be drawn into the system from a refrigerant container on weight scales. Continue to paragraph 6.7.

6.6.4 Procedure - Partial System

- a. If the refrigerant charge has been removed from the compressor for service, evacuate only the compressor by connecting the evacuation set-up at the compressor service valves. Follow evacuation procedures of the preceding paragraph except leave compressor service valves frontseated until evacuation is completed.
- b. If refrigerant charge has been removed from the low side only, evacuate the low side by connecting the evacuation set-up at the compressor service valves and liquid service valve except leave the service valves frontseated until evacuation is completed.
- c. Once evacuation has been completed and the pump has been isolated, fully backseat the service valves to isolate the service connections and then continue with checking and, if required, adding refrigerant in accordance with normal procedures.

6.7 REFRIGERANT CHARGE

6.7.1 Checking the Refrigerant Charge

NOTE

To avoid damage to the earth's ozone layer, use a refrigerant recovery system whenever removing refrigerant. When working with refrigerants you must comply with all local government environmental laws. In the U.S., refer to EPA section 608.

- a. Connect the gauge manifold to the compressor discharge and suction service valves. For units operating on a water cooled condenser, change over to air-cooled operation.
- b. Bring the container temperature to approximately 1.7°C (35°F) or -17.8°C (0°F). Set the controller set point to -25°C (-13°F) to ensure that the suction modulation valve is at maximum allowed open position.
- c. Partially block the condenser coil inlet air. Increase the area blocked until the compressor discharge pressure is raised to approximately 12kg/cm² (175psig).
- d. On units equipped with a receiver, the level should be between the glasses. On units equipped with a water-cooled condenser, the level should be at the center of the glass. If the refrigerant level is not correct, continue with the following paragraphs to add or remove refrigerant as required.

6.7.2 Adding Refrigerant to System (Full Charge)

- a. Evacuate unit and leave in deep vacuum (refer to paragraph 6.6).
- b. Place cylinder of R-134a on scale and connect charging line from cylinder to liquid line valve. Purge charging line at liquid line valve and then note weight of cylinder and refrigerant.
- c. Open liquid valve on cylinder. Open liquid line valve half-way and allow the liquid refrigerant to flow into the unit until the correct weight of refrigerant (refer to paragraph 2.2) has been added as indicated by scales.

NOTE

It may be necessary to finish charging unit through suction service valve in gas form, due to pressure rise in high side of the system (refer to section paragraph 6.7.3).

- d. Backseat manual liquid line valve (to close off gauge port). Close liquid valve on cylinder.
- e. Start unit in cooling mode. Run approximately 10 minutes and check the refrigerant charge.

6.7.3 Adding Refrigerant to System (Partial Charge)

- a. Examine the unit refrigerant system for any evidence of leaks. Repair as necessary (refer to paragraph 6.5).
- b. Maintain the conditions outlined in paragraph 6.7.1
- c. Fully backseat the suction service valve and remove the service port cap.
- d. Connect charging line between suction service valve port and cylinder of refrigerant R-134a. Open VAPOR valve.

- e. Partially frontseat (turn clockwise) the suction service valve and slowly add charge until the refrigerant appears at the proper level.

6.8 COMPRESSOR



WARNING

Make sure power to the unit is OFF and power plug disconnected before replacing the compressor.

NOTES

1. The compressor should not operate in a vacuum greater than 500mm/hg (20 inches/hg).
2. The service replacement compressor is sold without shutoff valves (but with valve pads), and without terminal box and cover. Customer should retain the original terminal box, cover, and high pressure switch for use on replacement compressor.
3. Check oil level in service replacement compressor (refer to paragraph 6.8.6).
4. A compressor terminal wiring kit must be ordered as a separate item when ordering replacement compressor. Appropriate installation instructions are included with kit.
5. Refer to Table 6-6 and Table 6-7 for applicable compressor wear limits and torque values.
6. Refer to Figure 6-36 for charts on compressor pressure, temperature and motor current curves.

6.8.1 Removal and Replacement of Compressor

- a. Remove the protective guard from lower section of the unit.
- b. Pump down low side (refer to paragraph 6.4) or front-seat compressor service valves and remove refrigerant from compressor using a refrigerant recovery system.
- c. Locate the compressor junction box. Tag and disconnect wiring from compressor terminals and remove compressor junction box.
- d. Loosen service valve mounting bolts, break seal, and then remove bolts.
- e. Remove compressor plate mounting bolts.
- f. Remove compressor and mounting plate. Refer to paragraph 2.2 for weight of compressor.
- g. Remove high pressure switch (HPS) from compressor and check operation of switch (refer to paragraph 6.9.2).

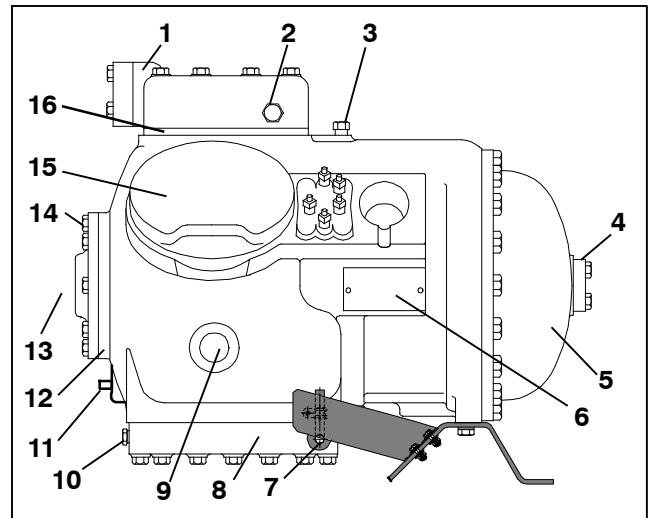

- | | |
|----------------------------------|------------------------|
| 1. Discharge Valve Flange | 8. Bottom Plate |
| 2. High Side Pressure Connection | 9. Sight Glass |
| 3. Low Side Pressure Connection | 10. Oil Drain Plug |
| 4. Suction Valve Flange | 11. Oil Charging Valve |
| 5. Motor End Cover | 12. Bearing Head |
| 6. Serial/Model No. Plate | 13. Oil Pump |
| 7. Crankcase Heater | 14. Oil Fill Plug |
| | 15. Cylinder Head |
| | 16. Valve Plate |

Figure 6-6 Compressor

- h. Remove compressor mounting bolts from mounting plate and install mounting plate on replacement compressor.
- i. Install replacement compressor terminal wiring kit, following instructions included with kit.
- j. Install high pressure switch on compressor.
- k. Install compressor and mounting plate in unit.
- l. Connect junction box(es) to compressor and connect all wiring per wiring diagram. Install junction box cover(s).
- m. Install new gaskets on service valves.
- n. Install mounting bolts in service valves and torque to 2.77 to 4.15mkg (20-30ft/lb).
- o. Attach two hoses (with hand valves near vacuum pump) to the suction and discharge service valves. Dehydrate and evacuate compressor to 500 microns (75.9cm Hg vacuum = 29.90 inches Hg vacuum). *Turn off valves on both hoses to pump.*
- p. Fully backseat (open) both suction and discharge service valves.
- q. Remove vacuum pump lines.
- r. Start unit and check refrigerant charge (refer to paragraph 6.7).
- s. Check moisture-liquid indicator for wetness. Change filter-drier if necessary (refer to paragraph 6.13).
- t. Check compressor oil level per paragraph 6.8.6. Add oil if necessary.

6.8.2 Compressor Disassembly

WARNING

Before disassembly of any external compressor component make sure to relieve possible internal pressure by loosening the bolts and tapping the component with a soft hammer to break the seal.

CAUTION

Removing the compressor motor press-fit stator in the field is not recommended. The rotor and stator are a matched pair and should not be separated.

When disassembling compressor, matchmark parts so they may be replaced in their same relative positions (see Figure 6-6). Refer to Table 6-6 and Table 6-7 for compressor wear limits and bolt torque values.

- Place the compressor in a position where it will be convenient to drain the oil. Remove the oil fill plug (see Figure 6-6) to vent the crankcase. Loosen the drain plug in bottom plate and allow the oil to drain out slowly. Remove the plug slowly to relieve any crankcase pressure. Some units have a plug in the bottom center of the crankcase, which may be removed for draining the motor end more quickly.

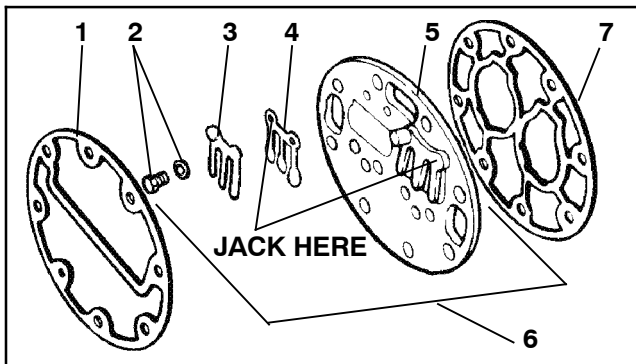

- | | |
|---------------------------------------|-------------------------|
| 1. Cylinder Head Gasket | 4. Discharge Valve |
| 2. Discharge Valve Screw & Lockwasher | 5. Valve Plate |
| 3. Discharge Valve Stop | 6. Valve Plate Assembly |
| | 7. Valve Plate Gasket |

Figure 6-7 Exploded View of Valve Plate

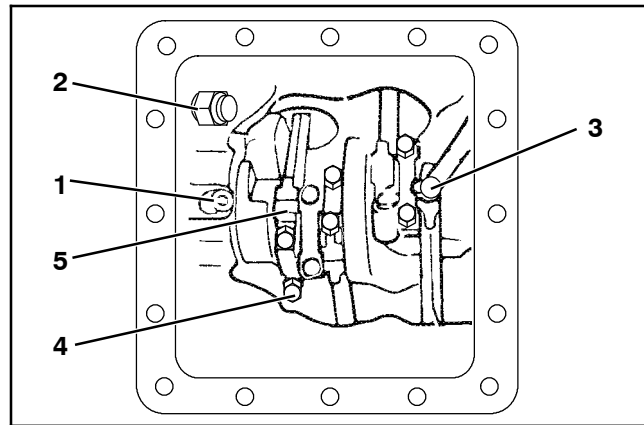

- | | |
|------------------------------|------------------------------------|
| 1. Oil Pressure Relief Valve | 3. Oil Suction Tube |
| 2. Oil Return Check Valve | 4. Cap screw |
| | 5. Connecting Rod and Cap Assembly |

Figure 6-8 Bottom Plate Removed

- Loosen cylinder head cap screws. If the cylinder head is stuck, tap the center of the cylinder head with a wooden or lead mallet. Do not strike the side of the cylinder head. Be careful not to drop the head or damage the gasket sealing surface. Remove cylinder head bolts and gasket (see Figure 6-7).
- Remove valve stops and valves. After they have been removed, free the valve plate from the cylinder deck by using the outside discharge valve hold-down cap screw as a jack screw through the tapped hole of the valve plate. Remove the valve plate gasket.
- Turn the compressor on its side and remove the bottom plate oil suction screen and screen hold down plate. Inspect the screen for holes or an accumulation of dirt. The screen can be cleaned with a suitable solvent.
- Match mark each connecting rod cap (see Figure 6-8) and connecting rod for correct reassembly. Remove the bolts and connecting rod caps. Push the piston rods up as far as they will go without having the piston rings extend above the cylinders.

CAUTION

The copper tube, which connects to the oil suction strainer extends out the bottom with the bottom plate removed. Take precautions to avoid bending or breaking it while changing crankcase positions.

- If necessary, remove the oil return check valve (see Figure 6-8). Inspect it for proper operation (flow in one direction only). Replace the assembly with a new unit if check valve operation is impaired.
- To remove the oil pump (see Figure 6-9) remove eight cap screws, oil pump bearing head assembly, gasket, and thrust washer.

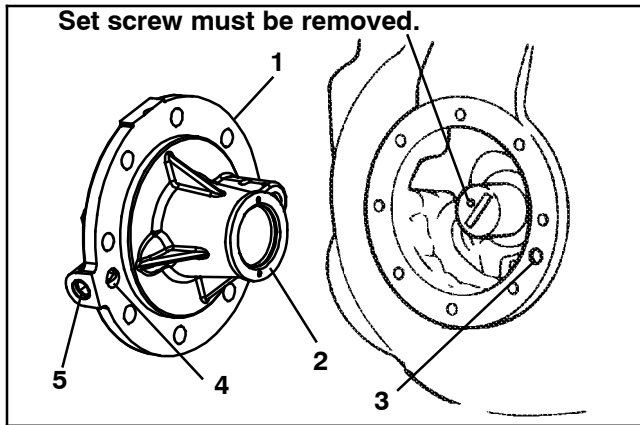

- | | |
|----------------------------|-------------------------|
| 1. Oil Pump & Bearing Head | 3. Oil Pickup Tube Head |
| 2. Thrust Washer | 4. Oil Inlet Port |
| | 5. Oil Pump Inlet |

Figure 6-9 Oil Pump and Bearing Head

NOTE

If the oil pump was not operating properly, the entire oil pump & bearing head assembly must be replaced. Individual parts are not available. If the pump requires inspection or cleaning, disassemble and reassemble by referring to Figure 6-10. Clean all parts and coat all moving parts with compressor oil before proceeding with reassembly.

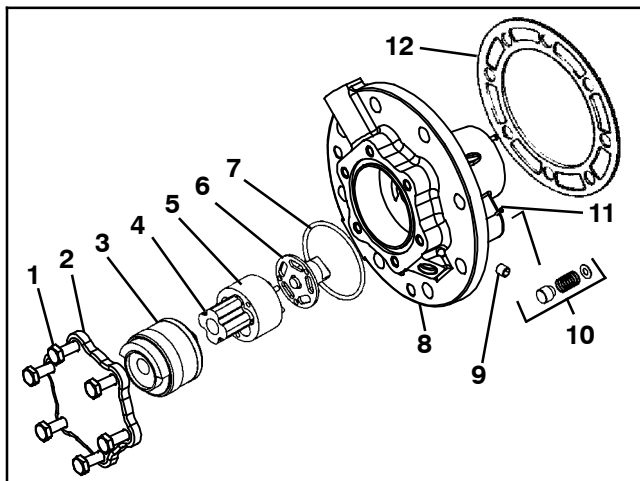

- | | |
|-----------------------|-----------------------|
| 1. Cap screws | 7. O-Ring |
| 2. Cover | 8. Oil Pump & Bearing |
| 3. Reversing Assembly | 9. Set Screw |
| 4. Pinion | 10. Relief Valve |
| 5. Gear | 11. Pin |
| 6. Drive | 12. Gasket |

Figure 6-10 Low Profile Oil Pump

h. Be very careful not to damage the motor windings when removing the motor end cover (see Figure 6-11), as the cover fits over the winding coils. Loosen the cap screws, break the seal, and then remove all cap screws except one in the top of the cover. While holding the cover in place, remove the remaining cap screw. Do not allow the cover to drop from its own weight. To prevent striking the winding, remove the cover horizontally and in line with the motor axis.

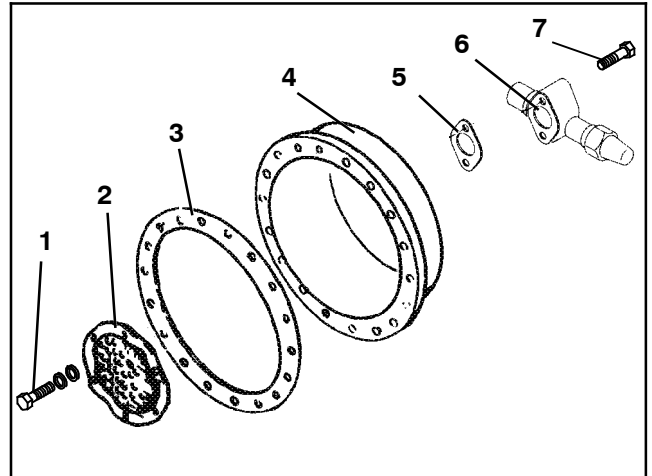

- | | |
|--------------------------------|---------------------------|
| 1. Strainer Screws and Washers | 4. Motor End Cover |
| 2. Suction Strainer | 5. Valve Gasket |
| 3. Motor End Cover | 6. Suction Service Valve |
| | 7. Valve Cap screw Gasket |

Figure 6-11 Motor End Cover

- i. Remove the refrigerant suction strainer. If it is removed with ease, it may be cleaned with solvent and replaced. If the strainer is broken, corroded or clogged with dirt that is not easily removed, replace the strainer. Install new gaskets upon reassembly.
- j. Block the compressor crankshaft so that it cannot turn. Use a screwdriver to bend back the tabs on the lockwasher, and remove the equalizer tube and lock screw assembly (see Figure 6-12). The slingers at the end of the tube draw vapor from the crankcase. Remove the rotor using a jack bolt. Insert a brass plug into the rotor hole to prevent damage to the end of the crankshaft.
- k. If the piston rings extend beyond the cylinder tops, the pistons can be pulled through the bottom plate opening after the piston rings are compressed. A piston ring compressor will facilitate removal. Each piston pin is locked in place by lock rings, which are snapped into grooves in the piston wall (see Figure 6-13).
- l. Since the stator cannot be replaced in the field, the terminal plate assembly need not be disturbed unless a leak exists and the plate assembly needs to be replaced. If no terminal plate repair is required, proceed with reassembly.

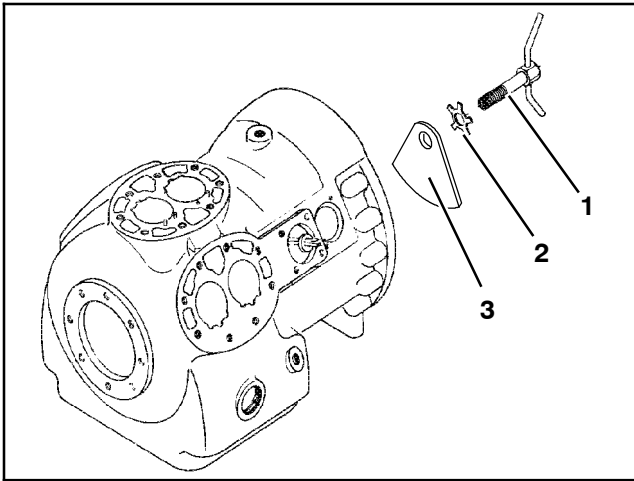

- 1. Equalizer Tube and Lock Screw Assembly
- 2. Lockwasher
- 3. Counterweight - Motor End

Figure 6-12 Equalizing Tube and Lock Screw Assembly

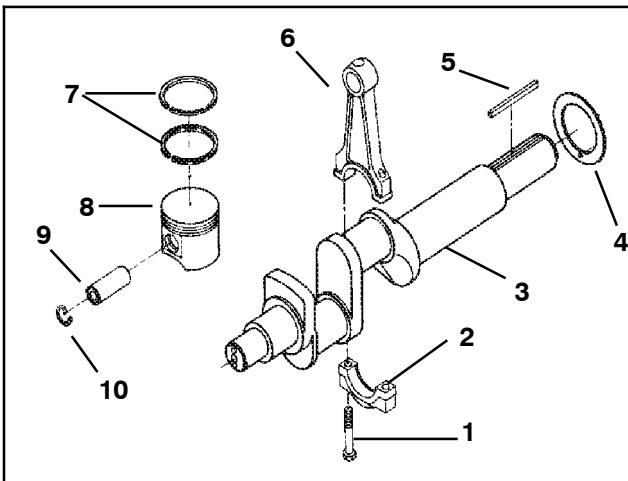

- 1. Cap screw
- 2. Cap
- 3. Crankshaft
- 4. Thrust Washer
- 5. Rotor Drive Key
- 6. Connecting Rod
- 7. Compression Ring
- 8. Piston
- 9. Pin
- 10. Retainer

Figure 6-13 Crankshaft Assembly

6.8.3 Compressor Reassembly

Clean all compressor parts, using a suitable solvent with proper precautions. Coat all moving parts with the proper compressor oil before assembly. Refer to Table 6-7 for applicable compressor torque values.

6.8.4 Preparation

a. Suction and Discharge Valves

If the valve seats look damaged or worn, replace valve plate assembly. Always use new valves because it is

difficult to reinstall used valves so that they will seat as before removal. Any valve wear will cause leakage.

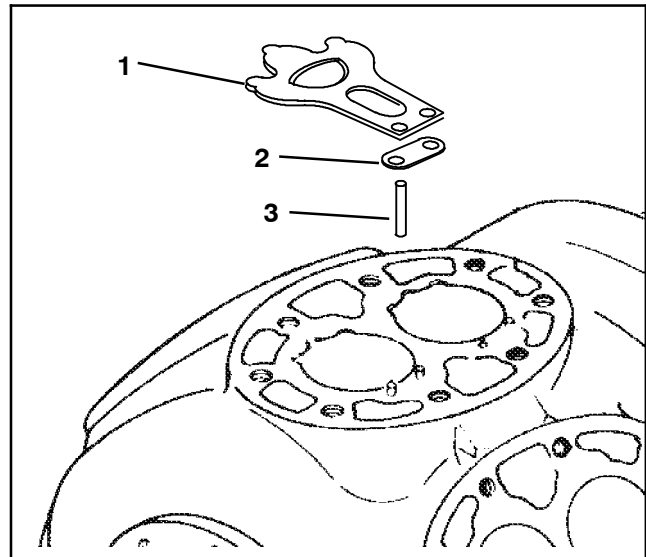

- 1. Suction Valve
- 2. Suction Valve Positioning Spring
- 3. Valve Plate Dowel Pin

Figure 6-14 Suction Valve & Positioning Springs

Suction valves are positioned by dowel pins (see Figure 6-14). Do not omit the suction valve positioning springs. Place the springs so that the ends bear against the cylinder deck (middle bowed away from cylinder deck). Use new gaskets when reinstalling valve plates and cylinder heads.

b. Compression Rings

The compression ring is chamfered on the inside circumference. This ring is installed with the chamfer toward the top. Stagger the ring end gaps so they are not aligned.

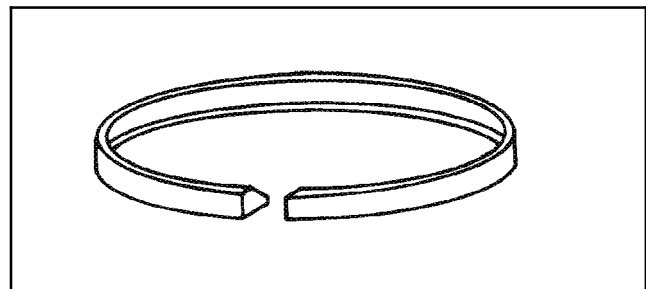

Figure 6-15 Piston Ring

The gap between the ends of the piston rings can be checked with a feeler gauge by inserting the ring into the piston bore approximately one inch below the top of the bore. Square the ring in the bore by pushing it slightly with a piston. The maximum and minimum allowable ring gaps are 0.33 and 0.127mm (0.013 and 0.005 inch) respectively.

6.8.5 Installing the Components

- a. Push pistons from the inside of the crankcase through the cylinders, being careful not to break the rings. Place rods so that the chamfered side will be against radius of crankpins. Install the crankshaft and thrust washer through the pump end of the compressor. Ensure thrust washer is fitted on locating pin. Do not damage main bearings. Bring rods in position against crank bearings.
- b. Install the pump end thrust washer on the two dowel pins located on the bearing head (see Figure 6-9).



CAUTION

Ensure that thrust washer does not fall off dowel pins while installing oil pump.



CAUTION

The set screw on the crankshaft must be removed for this type of oil pump (see Figure 6-9).

- c. Install the bearing head assembly with a new gasket on the compressor crankshaft. Carefully push oil pump on by hand, ensuring that the thrust washer remains on the dowel pins. The tang on the end of the drive engages the slot in the crankshaft, and the oil inlet port on the pump is aligned with the oil pickup tube in the crankcase. The pump should be mounted flush with the crankcase, and should be oriented with the oil pickup tube and oil inlet port aligned as shown in Figure 6-9.
- d. Align the gasket and install the eight cap screws in the mounting flange. Refer to Table 6-7 for applicable torque values.
- e. Install matching connecting rod caps. Be sure rod is not bound and crankshaft will turn correctly as each set of rod bolts is torqued.
- f. Be sure key fits properly when installing rotor on shaft. Screw on equalizer tube and lock screw assembly with lock washer and bend over tabs of lock washer. Assemble suction strainer to motor and cover, and bolt cover to crankcase. Assemble valve plates and gaskets. Assemble cylinder heads and gaskets. Turn the shaft by hand to see that it moves freely.
- g. Install the oil suction screen, the oil suction screen hold down plate, and the bottom plate.

6.8.6 Compressor Oil Level



CAUTION

Use only Carrier Transicold approved Polyol Ester Oil (POE) - Castrol-Icematic SW20 compressor oil with R-134a. Buy in quantities of one quart or smaller. When using this hygroscopic oil, immediately reseal. Do not leave container of oil open or contamination will occur.

a. Checking the Oil Level in the Compressor

1. Operate the unit in cooling mode for at least 20 minutes.
2. Check the front oil sight glass on the compressor to ensure that no foaming of the oil is present after 20 minutes of operation. If the oil is foaming excessively after 20 minutes of operation, check the refrigerant system for flood-back of liquid refrigerant. Correct this situation before performing step 3.
3. Turn unit off to check the oil level. The correct oil level range should be between the bottom to one-eighth level of the sight glass. If the level is above one-eighth, oil must be removed from the compressor. To remove oil from the compressor, follow step d in this section. If the level is below the bottom of the sight glass, add oil to the compressor following step b below.

b. Adding Oil with Compressor in System

1. The recommended method is to add oil using an oil pump at the oil fill valve (see item 11, Figure 6-6).
2. In an emergency where an oil pump is not available, oil may be drawn into the compressor through the suction service valve.

Connect the suction connection of the gauge manifold to the compressor suction service valve port, and immerse the common connection of the gauge manifold in an open container of refrigeration oil. Extreme care must be taken to ensure the manifold common connection remains immersed in oil at all times. Otherwise air and moisture will be drawn into the compressor. Crack the suction service valve and gauge valve to vent a small amount of refrigerant through the common connection and the oil to purge the lines of air. Close the gauge manifold valve.

With the unit running, frontseat the suction service valve and induce a vacuum in the compressor crankcase. SLOWLY crack the suction gauge manifold valve and oil will flow through the suction service valve into the compressor. Add oil as necessary.

c. Adding Oil to Service Replacement Compressor

Service replacement compressors are shipped without oil. If oil is present in the crankcase, it must be tested to ensure it is the correct oil and that the moisture level is acceptable.

When adding oil to a service replacement compressor add three liters (6.3 pints) using an oil pump at the oil fill valve (see item 11, Figure 6-6). This quantity is recommended to allow for return of any oil that may be in the refrigerant system. Install compressor and check oil level after it is placed in operation (refer to paragraph 6.8.6).

d. Removing Oil from the Compressor

1. If the oil level is above one-eighth sight glass, oil must be removed from the compressor.
2. Close (frontseat) suction service valve and pump unit down to 1.2 to 1.3kg/cm² (2 to 4psig). Frontseat discharge service valve and remove remaining refrigerant.
3. Loosen the oil drain plug on the bottom plate of the compressor and drain the proper amount of oil from the compressor to obtain the correct level. *Backseat the suction and discharge service valves.*
4. Repeat step a to ensure proper oil level.

6.9 HIGH PRESSURE SWITCH

6.9.1 Replacing High Pressure Switch

- Turn unit start-stop switch OFF. Frontseat both suction and discharge service valves to isolate compressor. Remove the refrigerant from the compressor.
- Disconnect wiring from defective switch. The high pressure switch is located on the center head and is removed by turning counterclockwise (see Figure 2-3).
- Install a new high pressure switch after verifying switch settings (refer to paragraph 6.9.2).
- Evacuate and dehydrate the compressor per paragraph 6.6.

6.9.2 Checking High Pressure Switch

WARNING

Do not use a nitrogen cylinder without a pressure regulator. Do not use oxygen in or near a refrigeration system as an explosion may occur.

NOTE

The high pressure switch is non-adjustable.

- Remove switch as outlined in paragraph 6.9.1
- Connect ohmmeter or continuity light across switch terminals. Ohm meter will indicate no resistance or continuity light will be illuminated if the switch closed after relieving compressor pressure.
- Connect hose to a cylinder of dry nitrogen (see Figure 6-16).
- Set nitrogen pressure regulator at 26.4kg/cm² (375psig) with bleed-off valve closed.
- Close valve on cylinder and open bleed-off valve.
- Open cylinder valve. Slowly close bleed-off valve to increase pressure on switch. The switch should open at a static pressure up to 25kg/cm² (350psig). If a light is used, light will go out. If an ohmmeter is used, the meter will indicate open circuit.
- Slowly open bleed-off valve to decrease the pressure. The switch should close at 18kg/cm² (250psig).

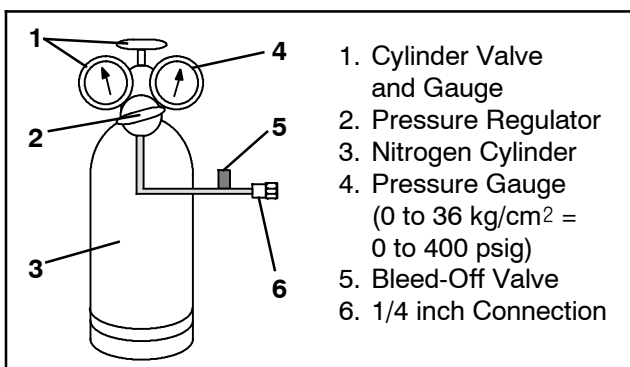

Figure 6-16 High Pressure Switch Testing

6.10 CONDENSER COIL

The condenser consists of a series of parallel copper tubes expanded into copper fins. The condenser coil must be cleaned with fresh water or steam so the air flow is not restricted. To replace the coil, do the following:

WARNING

Do not open the condenser fan grille before turning power OFF and disconnecting power plug.

- Using a refrigerant reclaim system, remove the refrigerant charge.
- Remove the condenser coil guard.
- Unsolder discharge line and remove the line to the receiver or water-cooled condenser.
- Remove coil mounting hardware and remove the coil.
- Install replacement coil and solder connections.
- Leak-check the coil connections per paragraph paragraph 6.5. Evacuate the unit per paragraph 6.6 then charge the unit with refrigerant per paragraph 6.7.

6.11 CONDENSER FAN AND MOTOR ASSEMBLY

WARNING

Do not open condenser fan grille before turning power OFF and disconnecting power plug.

The condenser fan rotates counter-clockwise (viewed from front of unit), pulls air through the the condenser coil and discharges horizontally through the front of the unit. To replace motor assembly:

- Open condenser fan screen guard.
- Loosen two square head set screws on fan (thread sealer has been applied to set screws at installation). Disconnect wiring from motor junction box.

CAUTION

Take necessary steps (place plywood over coil or use sling on motor) to prevent motor from falling into condenser coil.

- Remove motor mounting hardware and replace the motor. It is recommended that new locknuts be used when replacing motor. Connect wiring per wiring diagram.
- Install fan loosely on motor shaft (hub side in). DO NOT USE FORCE. If necessary, tap the hub only, not the hub nuts or bolts. Install venturi. Apply "Loctite H" to fan set screws. Adjust fan within venturi so that the outer edge of the fan projects 3.2 to 6.4mm (3/16" ±1/16") back from edge of the venturi. Spin fan by hand to check clearance.
- Close and secure condenser fan screen guard.
- Apply power to unit and check fan rotation. If fan rotates backward, reverse wire numbers 5 and 8.

6.12 WATER-COOLED CONDENSER CLEANING

The water-cooled condenser is of the shell and coil type with water circulating through the cupro-nickel coil. The refrigerant vapor is admitted to the shell side and is condensed on the outer surface of the coil.

Rust, scale, and slime on the water-cooling surfaces inside of the coil interfere with the transfer of heat, reduce system capacity, cause higher head pressures and increase the load on the system.

By checking the leaving water temperature and the actual condensing temperature, it can be determined if the condenser coil is becoming dirty. A larger than normal difference between leaving condensing water temperature and actual condensing temperature, coupled with a small difference in temperature of entering and leaving condensing water, is an indication of a dirty condensing coil.

To find the approximate condensing temperature, with the unit running in the cooling mode, install a gauge 0 to 36.2kg/cm² (0 to 500psig) on the compressor discharge service valve.

Example: Discharge pressure is 10.3kg/cm² (146.4psig). Referring to Table 6-8 (R-134a pressure/temperature chart), the 10.3kg/cm² (146.4psig) value converts to 43°C (110°F).

If the water-cooled condenser is dirty, it may be cleaned and de-scaled by the following procedure:

- Turn unit off and disconnect main power.
- Disconnect water pressure switch tubing by loosening the two flare nuts. Install one-quarter inch flare cap on water-cooled condenser inlet tube (replaces tubing flare nut). De-scale tubing if necessary.

What You Will Need:

- Oakite Aluminum Cleaner® 164, available as a powder in 20kg (44lb) pails and 205kg (450lb) drums.
- Oakite composition No. 32, available as a liquid in cases, each containing 3.785 liters (4 U.S. gallon) bottles and also in carboys of 52.6kg (116lbs) net.
- Fresh clean water.
- Acid proof pump and containers or bottles with rubber hose.

NOTE

When Oakite compound No. 32 is being used for the first time, the local Oakite Technical Service representative should be called in for assistance in planning the procedure. They will advise the reader on how to do the work with a minimum dismantling of equipment, estimate the time and amount of compound required, preparation, how to control and conclude the de-scaling operation by rinsing and neutralizing equipment before putting it back into service.

Summary of Procedure:

- Drain water from condenser tubing circuit.
- Clean water tubes with Aluminum Cleaner® 164 to remove mud and slime. Clean water tubes with Oakite No. 22 to remove mud and slime.
- Flush.
- De-scale water tubes with Oakite No. 32 to remove scale.
- Flush.
- Neutralize.
- Flush.

- Put unit back in service under normal load and check head (discharge) pressure.

Detailed Procedure:

- Drain and flush the water circuit of the condenser coil. If scale on the tube inner surfaces is accompanied by slime, a thorough cleaning is necessary before de-scaling process can be accomplished.
- To remove slime or mud, use Aluminum Cleaner® 164. Mix 170 grams (6 ounces) per 3.785 liters (1 U.S. gallon) of water. Mix cleaner in one half the volume of water, while stirring, and then add remaining water. Warm this solution and circulate through the tubes until all slime and mud has been removed.
- After cleaning, flush tubes thoroughly with fresh clean water.
- Prepare a 15% by volume solution for de-scaling by diluting Oakite compound No. 32 with water. This is accomplished by slowly adding 0.47 liter (1 U.S. pint) of the acid (Oakite No. 32) to 2.8 liters (3 U.S. quarts) of water.



WARNING

Oakite No. 32 is an acid. Be sure that the acid is slowly added to the water. DO NOT PUT WATER INTO THE ACID - This will cause spattering and excessive heat.



WARNING

Wear rubber gloves and wash the solution from the skin immediately if accidental contact occurs. Do not allow the solution to splash onto concrete. PUT WATER INTO THE ACID - this will cause spattering and excessive heat.

- Fill the tubes with this solution by filling from the bottom. See Figure 6-17.

NOTE

It is important to provide a vent at the top for escaping gas.

- Allow the Oakite No. 32 solution to soak in the tube coils for several hours, periodically pump-circulating it with an acid-proof pump.

An alternate method may be used whereby a pail (see Figure 6-18) filled with the solution and attached to the coils by a hose can serve the same purpose by filling and draining. The solution must contact the scale at every point for thorough de-scaling. Air pockets in the solution should be avoided by regularly opening the vent to release gas. *Keep flames away from the vent gases.*

- The time required for de-scaling will vary, depending upon the extent of the deposits. One way to determine when de-scaling has been completed is to titrate the solution periodically, using titrating equipment provided free by the Oakite Technical Service representative. As scale is being dissolved, titrate readings will indicate that the Oakite No. 32 solution is losing strength. When the reading remains constant for a reasonable time, this is an indication that scale has been dissolved.

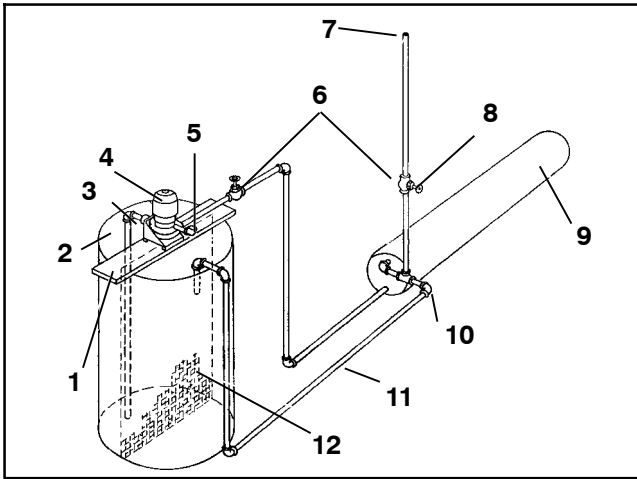

- | | |
|---|---|
| 1. Pump support | 7. Vent |
| 2. Tank | 8. Close vent pipe valve when pump is running |
| 3. Suction | 9. Condenser |
| 4. Pump | 10. Remove water regulating valve |
| 5. Priming Connection (Centrifugal pump 50 gpm at 35' head) | 11. Return |
| 6. Globe valves | 12. Fine mesh screen |

Figure 6-17 Water-Cooled Condenser Cleaning - Forced Circulation

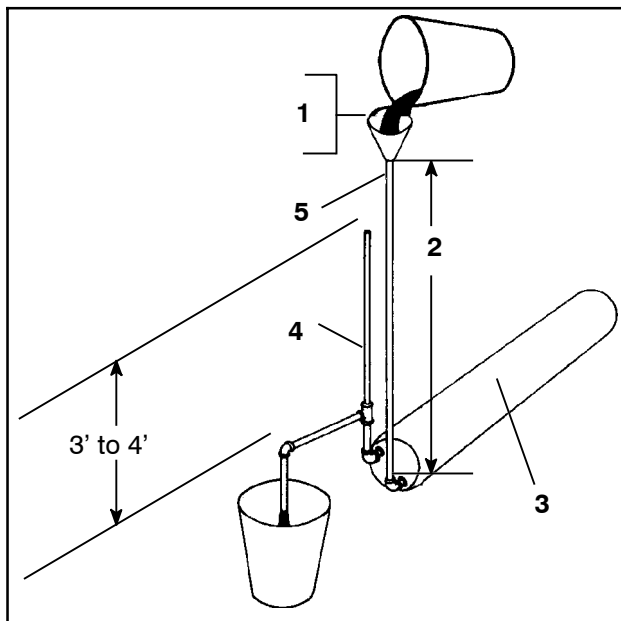

- | | |
|---|---------------------|
| 1. Fill condenser with cleaning solution. Do not add solution more rapidly than vent can exhaust gases caused by chemical action. | 2. Approximately 5' |
| | 3. Condenser |
| | 4. Vent pipe |
| | 5. 1" pipe |

Figure 6-18 Water-Cooled Condenser Cleaning - Gravity Circulation

- When de-scaling is complete, drain the solution and flush thoroughly with water.
- Following the water flush, circulate a 56.7 gram (2 ounce) per 3.785 liter (1 U.S. gallon) solution of

Oakite Aluminum Cleaner® 164 thru the tubes to neutralize. Drain this solution.

- Flush the tubes thoroughly with fresh water.

NOTE

If the condenser cooling water is not being used as drinking water or is not re-circulated in a closed or tower system, neutralizing is not necessary.

- Put the unit back in service and operate under normal load. Check the head pressure. If normal, a thorough de-scaling has been achieved.

What You Can Do For Further Help:

Contact the Engineering and Service Department of the OAKITE PRODUCTS CO., 675 Central Avenue, New Providence, NJ 07974 U.S.A. (or visit www.oakite.com) for the name and address of the service representative in your area.

6.13 FILTER-DRIER

On units equipped with a water-cooled condenser, if the sight glass appears to be flashing or bubbles are constantly moving through the sight glass when the suction modulation valve is fully open, the unit may have a low refrigerant charge or the filter-drier could be partially plugged.

a. To Check Filter-Drier:

- Test for a restricted or plugged filter-drier by feeling the liquid line inlet and outlet connections of the drier cartridge. If the outlet side feels cooler than the inlet side, then the filter-drier should be changed.
- Check the moisture-liquid indicator if the indicator shows a high level of moisture, the filter-drier should be replaced.

b. To Replace Filter-Drier:

- Pump down the unit (refer to paragraph 6.4 and replace filter-drier.
- Evacuate the low side in accordance with paragraph 6.6.
- After unit is in operation, inspect for moisture in system and check charge.

6.14 THERMOSTATIC EXPANSION VALVE (TXV)

The thermostatic expansion valve (see Figure 2-2) is an automatic device that maintains constant superheat of the refrigerant gas leaving the evaporator, regardless of suction pressure.

The valve functions are:

- Automatic control of the refrigerant flow to match the evaporator load.
- Prevention of liquid refrigerant entering the compressor.

Unless the valve is defective, it seldom requires maintenance other than periodic inspection to ensure that the thermal bulb is tightly secured and properly insulated. See Figure 6-19.

NOTE

TXV Bulb Clamp is soldered to the suction line.

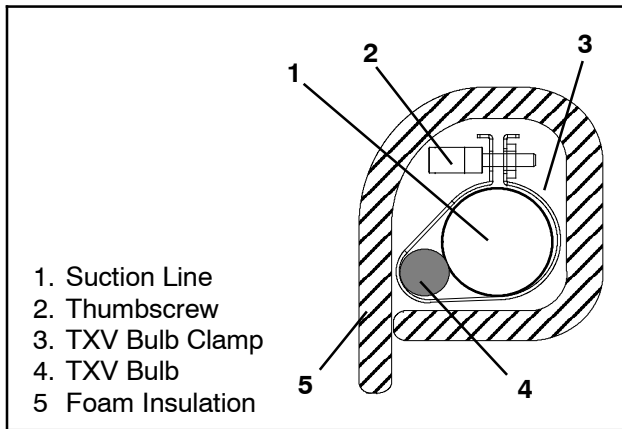

1. Suction Line
2. Thumbscrew
3. TXV Bulb Clamp
4. TXV Bulb
5. Foam Insulation

Figure 6-19 Thermostatic Expansion Valve Bulb

6.14.1 Checking Superheat

NOTE

Proper superheat measurement should be completed at -18°C (0°F) container box temperature where possible.

- a. Open the upper right (EFM#1) access panel (see Figure 2-1) to expose the expansion valve.
- b. Attach a temperature sensor near the expansion valve bulb and insulate. Make sure the suction line is clean and that firm contact is made with the sensor.
- c. Connect an accurate gauge to the service port directly upstream of the suction modulating valve.
- d. Set the temperature set point to -18°C (0°F) and run unit until conditions stabilize.
- e. The readings may cycle from a high to a low reading. Take readings of temperature and pressure every three to five minutes for a total of 5 or 6 readings.
- f. From the temperature/pressure chart (Table 6-8), determine the saturation temperature corresponding to the evaporator outlet test pressures at the suction modulation valve.
- g. Subtract the saturation temperatures determined in step f from the temperatures measured in step e.

The difference is the superheat of the suction gas. Determine the average superheat. It should be 4.5 to 6.7°C (8 to 12°F).

6.14.2 Expansion Valve Replacement

a. Removing the Expansion Valve

NOTES

1. The TXV is a hermetic valve and does not have adjustable superheat (See Figure 6-20).
2. All connections on the hermetic TXV are bi-metallic, copper on the inside and stainless on the outside.
3. All joints on the hermetic TXV (inlet, outlet and equalizer lines) are brazed.
4. Bi-metallic connections heat up very quickly.

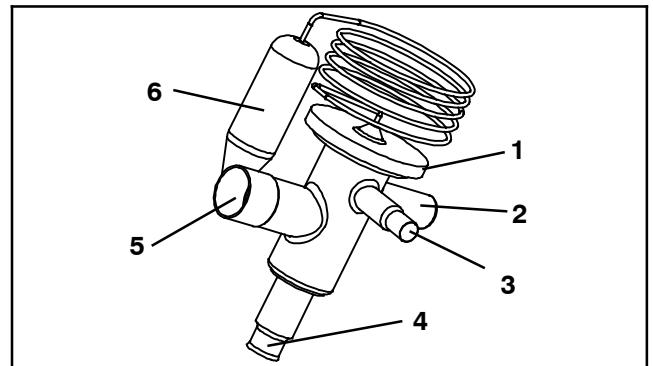

1. Hermetic Thermostatic Expansion Valve (TXV)
2. Non-adjustable Superheat Stem
3. Equalizer Connection
4. Inlet Connection
5. Outlet Connection
6. Hermetic Expansion Valve Bulb

Figure 6-20 Thermostatic Expansion Valve

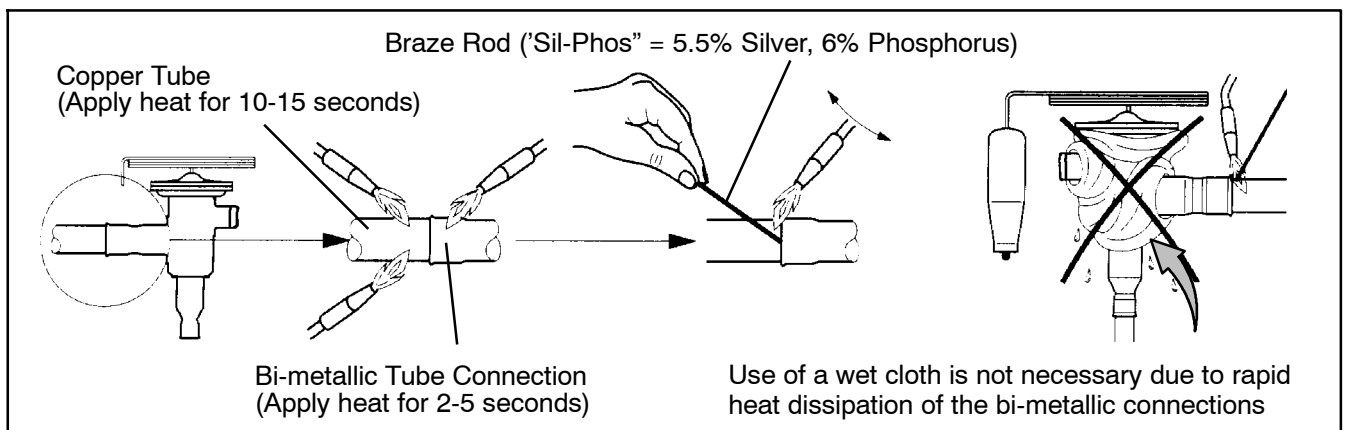
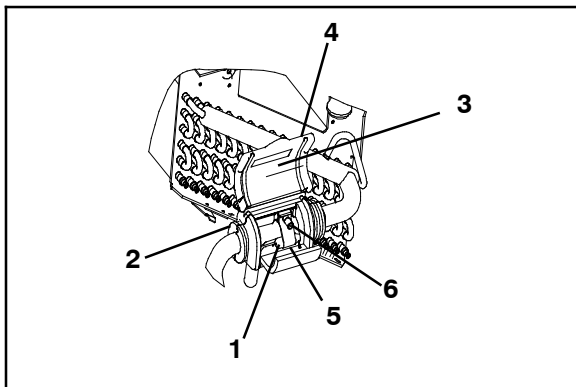

Figure 6-21 Hermetic Thermostatic Expansion Valve Brazing Procedure

1. Pump down the unit per paragraph 6.4.
2. If TXV replacement is to be performed from the front of the unit, open the upper right (EFM#1) access panel (see Figure 2-1) and remove the evaporator fan motor.
3. Remove cushion clamp that secures the valve body to the bracket.
4. Unbraid the equalizer connection (1/4"), the outlet connection (5/8"), and then the inlet connection (3/8"). See Figure 6-21. Be careful to protect the insulation on the heaters and their wires.
5. If TXV replacement is being performed from the front of the unit, remove the access panel for the bulb.
6. Open the insulation flap. Flap is secured with Velcro (Item 3, Figure 6-22).
7. Loosen the thumb screw and slide the bulb, out by pulling it towards the front of the unit.



1. Hermetic Expansion Valve Bulb
2. Insulation
3. Insulation Flap
4. Velcro strip
5. Bulb Clamp
6. Thumb Screw

Figure 6-22 Hermetic Thermostatic Expansion Valve Bulb Location

- b. Installing the Expansion Valve
 1. Braze inlet connection to inlet line (see Figure 6-21).
 2. Braze outlet connection to outlet line.
 3. Braze the equalizer connection to the equalizer line.
 4. Reinstall the cushion clamp.
 5. Thread the thermal bulb through the opening above the evaporator coil (see Figure 2-2), and slide it under the strap and secure the thumb screw. Close the insulation flap. Reinstall bulb access panel.
 6. Check superheat (refer to step 6.14.1).

6.15 EVAPORATOR COIL AND HEATER ASSEMBLY

The evaporator section, including the coil, should be cleaned regularly. The preferred cleaning fluid is fresh water or steam. Another recommended cleaner is Oakite 202 or similar, following *manufacturer's instructions*.

The drain pan hose is routed behind the condenser fan motor and compressor. The drain pan line must be open to ensure adequate drainage.

6.15.1 Evaporator Coil Replacement

- a. Pump unit down (refer to paragraph 6.4).
- b. With power OFF and power plug removed, remove the screws securing the panel covering the evaporator section (upper panel).
- c. Disconnect the defrost heater wiring.
- d. Disconnect the defrost temperature sensor (see Figure 2-2) from the coil.
- e. Remove middle coil support.
- f. Remove the mounting hardware from the coil.
- g. Unsolder the two coil connections, one at the distributor and the other at the coil header.
- h. After defective coil is removed from unit, remove defrost heaters and install on replacement coil.
- i. Install coil assembly by reversing above steps.
- j. Leak check connections per paragraph 6.5. Evacuate the unit per paragraph 6.6, and add refrigerant charge per paragraph 6.7.

6.15.2 Evaporator Heater Replacement

The heaters are wired directly back to the contactor. If a heater failure occurs during a trip, the heater set containing that heater may be disconnected at the contactor.

The next pre-trip will detect that a heater set has been disconnected and indicate that the failed heater should be replaced. To replace a heater, do the following:

- a. Before servicing unit, make sure the unit circuit breakers (CB-1 & CB-2) and the start-stop switch (ST) are in the OFF position, and that the power plug is disconnected.
- b. Remove the upper back panel.
- c. Determine which heater(s) need replacing by checking resistance of each heater set. Refer to paragraph 2.3 for heater resistance values. Once the set containing the failed heater is determined, cut the splice connection and retest to determine the actual failed heater(s).
- d. Remove hold-down clamp securing heater(s) to coil.
- e. Lift the bent end of the heater (with the opposite end down and away from coil). Move heater to the side enough to clear the heater end support and remove.

6.16 EVAPORATOR FAN AND MOTOR ASSEMBLY

The evaporator fans circulate air throughout the container by pulling air in through the bottom of the unit. The air is forced through the evaporator coil where it is either heated or cooled and then discharged out the top of the refrigeration unit into the container. The fan motor bearings are factory lubricated and do not require additional grease.



WARNING

Always turn OFF the unit circuit breakers (CB-1 & CB-2) and disconnect main power supply before working on moving parts.

- Remove upper access panel (See Figure 2-1) by removing mounting bolts and T.I.R. locking device. Reach inside of unit and remove Ty-Rap securing wire harness loop.
- Remove the two lower mounting bolts that secure the motor-fan assembly to the unit. Loosen the two upper bolts as the motor mount upper holes are slotted.
- Remove motor, fan, and wiring from unit. Place fan motor and fan on a support. Remove the wiring and fan.
- Lubricate fan motor shaft with a graphite-oil solution (Never-Seez). Apply thread sealer (Loctite H, brown in color) to the two fan set screws. Install fan on motor. The evaporator fan locating dimension is shown in Figure 6-23.

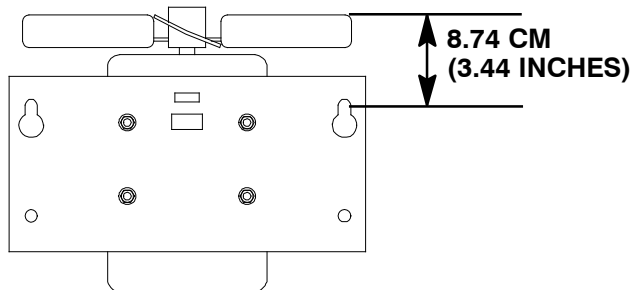
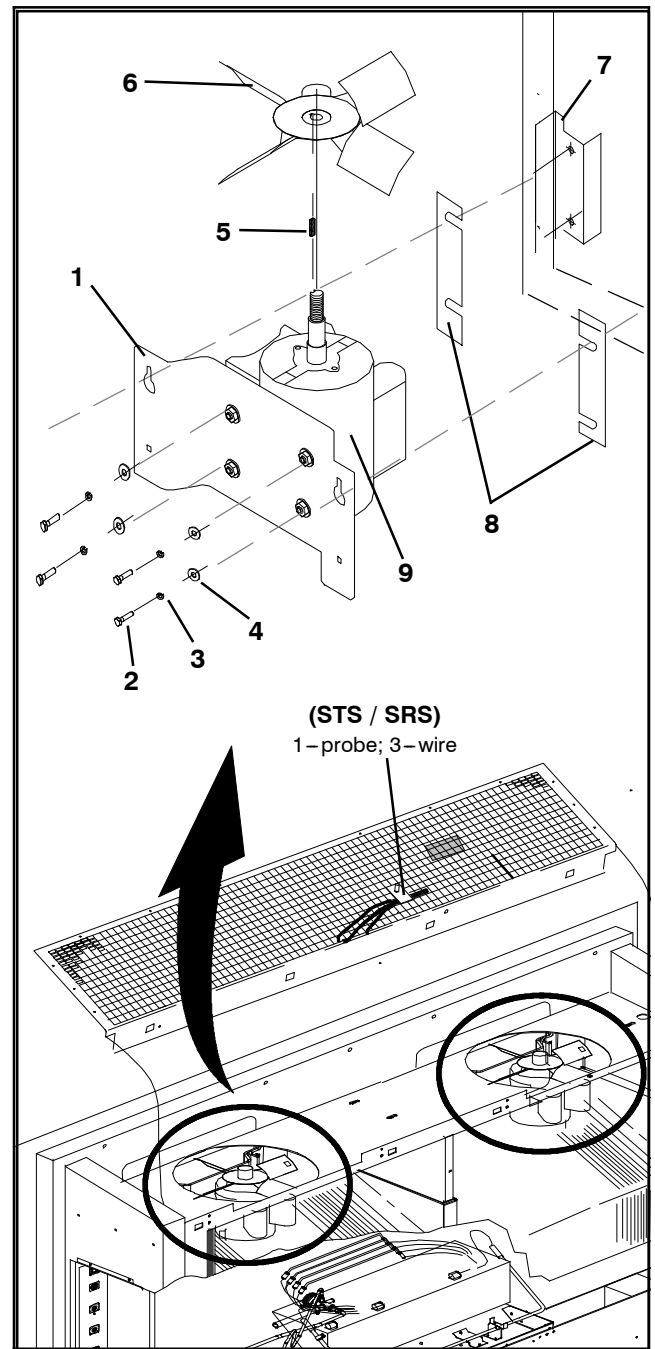

Figure 6-23 Evaporator Fan Locating Dimension

- Connect wiring per applicable wiring diagram and install motor and fan assembly in unit. Apply power, momentarily, to check fan rotation. If fan spins backwards, refer to section 2.3 for two-speed motors.
- Replace access panel, making sure panel does not leak. Make sure that the T.I.R. locking device is lock-wired.



- | | |
|-------------------------------------|---|
| 1. Bracket Motor Mount | 5. Key, 3/16 square x 1-3.8 x 1.00 lg - SST |
| 2. Bolt, Hex Head, 3/8-16 x 1.00 lg | 6. Evaporator Fan |
| 3. Washer, Lock, 3/8 | 7. Bracket, Mounting |
| 4. Washer, Flat, 3/8 | 8. Shim (if required) |
| | 9. Evaporator Motor |

Figure 6-24 Evaporator Fan Assembly

6.17 EVAPORATOR FAN MOTOR CAPACITORS

The evaporator fan motors are of the permanent-split capacitor type. The motor is equipped with one capacitor used in the high speed circuit, and another capacitor is used for the low speed circuit.

6.17.1 When To Check For a Defective Capacitor

- a. Fan motor will not change speed. For example: in the conventional perishable mode, the motors should run in high speed. In the economy perishable mode they should switch speeds and in the frozen mode, the motors should run in low speed.

NOTE

The evaporator fan motors will always start in high speed.

- b. Motor running in wrong direction (after checking for correct wiring application).
- c. Motor will not start and IP-EMs are not open.

6.17.2 Removing the Capacitor



Make sure power to the unit is OFF and power plug disconnected before servicing capacitor(s).



With power OFF discharge the capacitor before disconnecting the circuit wiring.

Capacitors must be discharged properly before testing. To discharge the capacitor, first turn the unit power OFF and disconnect the unit power plug. Then place a 20,000 ohm, 2 watt resistor across the terminals of the capacitor for approximately 30 seconds.

The capacitors are located on the motor and may be removed by two methods:

1. *If container is empty*, open upper rear panel of the unit.
2. *If container is full*, turn the unit power OFF and disconnect power plug. Remove the evaporator fan motor access panel (see Figure 2-1). For removal of the evaporator fan assembly, refer to section 6.16.

6.17.3 Checking the Capacitor

If the capacitor is suspected of malfunction, you may choose to simply replace it. Direct replacement requires a capacitor of the same value. Two methods for checking capacitor function are:

1. Volt-ohmmeter set on RX 10,000 ohms.

Connect ohmmeter leads across the capacitor terminals and observe the meter needle. If the capacitor

is good, the needle will make a rapid swing toward zero resistance and then gradually swing back toward a very high resistance reading.

If the capacitor has failed open, the ohmmeter needle will not move when the meter probes touch the terminals. If the capacitor is shorted, the needle will swing to zero resistance position and stay there.

2. Capacitor analyzer:

The function of the analyzer is to read the microfarad value of a capacitor and to detect insulation breakdown under load conditions. The important advantages of an analyzer are its ability to locate capacitors that have either failed to hold their microfarad ratings or those that are breaking down internally during operation. It is also useful in identifying capacitors when their microfarad rating marks have become unreadable.

6.18 EVAPORATOR SECTION CLEANING

Containers and Container units that are exposed to certain fumigants may develop visible surface corrosion. This corrosion will show up as a white powder found on the inside of the container and on the reefer unit evaporator stator and fan deck.

Analyses by Carrier Transicold environmental specialists have identified the white powder as consisting predominantly of aluminum oxide. Aluminum oxide is a coarse crystalline deposit most likely the result of surface corrosion on the aluminum parts within the container. If left untreated over time, it may build up in thickness and eventually flake as a light-weight white powder.

The surface corrosion of aluminum is brought about by exposure to chemicals such as sulfur dioxide and possibly other fumigants that are commonly used for fumigation and protection of some perishable cargo such as grapes, for example. Fumigation is the process by which a chemical is released into an enclosed area to eliminate infestations of insects, termites, rodents, weeds and soil-born disease.

Typically any aluminum oxide that becomes detached from evaporator fan stators will be blown into the wet evaporator coil where it will be caught and then flushed out of the unit during routine defrost cycles.

However, it is still highly recommended that after carrying cargo subject to fumigation procedures, that the inside of the unit be thoroughly cleansed prior to reuse.

Carrier Transicold has identified a fully biodegradable and environmentally safe alkaline cleaning agent (Tri-Pow'r® HD) for the unit. This will assist in helping to remove the corrosive fumigation chemicals and dislodging of the corrosive elements.

This cleaner is available from the Carrier Transicold Performance Parts Group (PPG) and can be ordered through any of the PPG locations; Part Number NU4371-88.

As a general safety precaution, before using this product, refer to and retain the Material Safety Data (MSDS) sheet. This document can be found at:

www.nucalgon.com/products/coil_cleaners_tripower.htm

Prior to Cleaning:

- Always wear goggles, gloves and work boots.
- Avoid contact with skin and clothing, and avoid breathing mists.
- When mixing, add water to the sprayer first, then the cleaner.
- ALWAYS provide for proper ventilation when cleaning indoor evaporator coils (rear doors must be open).
- Be aware of surroundings – food, plants, etc., and the potential for human exposure.
- Always read directions and follow recommended dilution ratios. More is not always better. Using non-diluted cleaner is not recommended.

Cleaning Procedure:

- a. Remove the upper evaporator access panel inside of the unit.
- b. Spray the surface with water before applying the cleaning solution. This helps the cleaner work better.
- c. Liberally apply the prepared cleaner solution (5 parts water and 1 part cleaner).
- d. Allow the cleaner to soak in for 5 to 7 minutes.
- e. Assess area for rinsing. Follow all local regulations regarding disposal of waste water.
- f. Thoroughly rinse the cleaner and surrounding area, floor, etc. When rinsing where heavy foaming solution is present, it is very important to take the time to thoroughly rinse the equipment and surroundings.
- g. Always rinse the empty coil cleaner bottle, cap tightly and dispose of properly.

6.19 SUCTION MODULATION VALVE (SMV)

On start up of the unit, the valve will reset to a known open position. This is accomplished by assuming the valve was fully open, driving it fully closed, resetting the percentage open to zero, then opening to a known 21% staging position.

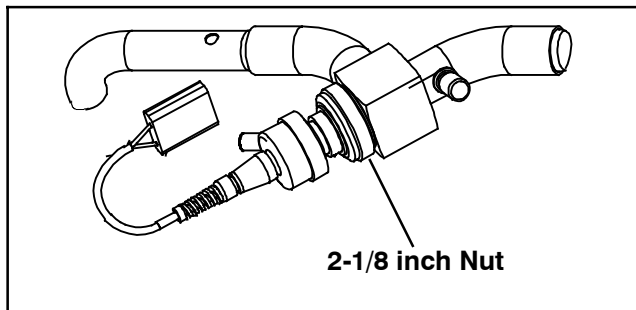

Figure 6-25 Suction Modulation Valve (SMV)

6.19.1 Pre-check Procedure

- a. Check unit for abnormal operation.
- b. Check charge. If refrigerant is low repair as required and again check operation.
- c. If sufficient capacity cannot be maintained or unit is tripping excessively on high pressure switch (HPS) in high ambients, check coils and clean if required.

- d. If capacity or control cannot be maintained, turn unit OFF, then back ON. This will reset the valve in the event the controller lost communication with the valve, and may correct the problem.

NOTE

Carefully listen to the valve. During reset, the valve will make a ratcheting noise that may be heard or felt as it is attempting to close. If this can be heard or felt, it indicates that the controller and drive module are attempting to close the valve, and may serve as a quick indication that the drive module is in working order.

- e. During the first few minutes of unit operation, compressor reliability enhancement logic (CREL) may be in effect. This places the valve at a 21% staging position and is sufficient to drive the temperature of the supply probe down several degrees during this interval.
- f. After the CREL time-out has been met, the valve will start responding to the control logic and open or close relative to the demand. Scrutinize the unit operation for a few minutes. While in pulldown, the unit will open the SMV to a maximum discharge pressure of 325 psig in high ambient conditions, or as much as the current setting and control logic will allow. The current level should be high. A lower discharge pressure will be seen in lower ambient temperatures. Once the unit has reached set point, the SMV will go into control mode. Both the discharge/suction pressures, and current draw will go significantly lower. Once below set point, the suction pressure should go into a vacuum within several minutes. Should the operation differ as mentioned, the SMV, controller, or wiring, may be faulty.
- g. Check for correct wire location at the stepper motor plug and the environmental connector (EC). Make sure that the wires terminate in accordance with the wire markings (addresses).
- h. Attach a manifold gauge set (refer to paragraph 6.3). If the unit is operating in the perishable mode, proceed to step i. If the unit is operating in the frozen mode, proceed to step j.
- i. Perishable operation: If the operation of the unit is in question, place the set point to approximately 6°C (11°F) less than the current box temperature, so the unit goes into pulldown. Run the unit for approximately one minute. Record readings on gauges and current draw. The current draw and pressures should go up. Place set point 0.5°C (0.9°F) above current box temperature to fully modulate valve, and run for approximately one minute.

NOTE

The unit may shut off for a short time. Wait until the unit self starts and sufficient time has elapsed to cause the valve to fully modulate.

Record new gauge readings and current draw. The suction pressure should go into a vacuum and the current draw should have gone down. If little or no change to the suction pressure or current draw occurs, this is an indication of a malfunctioning SMV.

- j. Frozen operation: In frozen mode the valve tends to stay open as much as possible. Again, this is dependent upon current limit setting and control logic. Turn the unit OFF and ON, as in the perishable mode, and watch the gauges. The valve will run at 21% open if CREL logic is active, and will open to maximum allowable after this. Depending on ambient conditions, there should be an increase in suction pressure and current draw as the valve opens. However, at times, this may be difficult to fully determine.
- k. If the unit still does not operate properly, stop unit and proceed to the following step to check out the SMV system.

6.19.2 Checking the Stepper Valve

a. Checking with ohmmeter

Disconnect the 4-pin connector to the stepper SMV. With a reliable digital ohmmeter, check the winding resistance. In normal ambient, the valve should have 72 to 84 ohms measured on the red/green (a-b terminals) and on the white/black (c-d terminals) leads. If an infinite or zero reading occurs, check connections and replace the motor. If near normal or normal reading occurs, proceed to step 6.19.3 to check out the controller.

b. Checking with SMA-12 portable stepper drive tester

The SMA-12 portable stepper drive tester (Carrier Transicold P/N 07-00375-00) is a battery-operated stepper drive that will open and close the SMV, allowing a more thorough check of the motor.

To check operation:

1. Stop the unit, disconnect the 4-pin connector from the stepper module to the valve (see Figure 6-25) and attach the SMA-12 stepper drive to the connector going to the valve.
2. Set the SMA-12 pulse per second (PPS) to one PPS and either open or close valve. Each LED should light sequentially until all four are lit. Any LED failing to light indicates an open on that leg, which indicates a poor connection or an open coil. Repair or replace as required to achieve proper operation.
3. Restart unit, set the step rate to 200 PPS on SMA-12 for the valve, and close stepper valve while watching the suction gauge. Within one minute the suction pressure will go into a vacuum. This is an indication that the valve is moving.
4. If no change in suction pressure is detected, check for resistance (refer to step 6.19.2), and check connections for proper continuity and retest. If the valve is functioning, and all connections and motor resistance are good, check the drive module (refer to step 6.19.3).

5. If the valve is determined to be faulty after completing the above steps, perform a low side pump down. Remove valve powerhead assembly, and replace with a NEW valve powerhead assembly, torque nut to 35 ft-lb, evacuate low side, and open all service valves.



CAUTION

DO NOT disassemble piston from NEW suction modulating valve powerhead assembly. Doing so may result in damage to piston.

6.19.3 Checking the Controller

- a. Turn unit OFF.
- b. With voltmeter set to read 20 volts DC, attach the positive lead to MC1 of the 4-pin connector and the negative lead to the TP9. Turn ON unit and watch the volt meter. After a short delay, the reading should remain unchanged at 0 volts. If 5VDC, check jumper wire from MC1 to MC8 is in place; if not, install and retest.

6.19.4 Emergency Repair Procedures

In the event that the SMV system has a failure and replacement components are not readily available, the system can be bypassed by removing the valve piston. To remove the piston, do the following:

- a. Perform a low side pump down (refer to paragraph 6.4).
- b. Remove SMV powerhead by loosening the 2-1/8 inch diameter nut (see Figure 6-25) to relieve any pressure and then sliding the powerhead out.
- c. Remove the piston by loosening the Allen screw and removing the piston and screw.
- d. Install the powerhead assembly (without the piston) and torque to 35 to 40 foot-lbs.
- e. Open all valves.
- f. Start the unit.
- g. Adjust the suction service valve so that the approximate temperature OR current limit is maintained. For perishable loads, it is recommended that the adjustment be made so that the available capacity is slightly larger than the load. The unit will cycle OFF and ON.
- h. Once repair parts become available, repair as required.

6.20 DPRV CHECK PROCEDURE

The discharge pressure regulating valve (DPRV) is designed to maintain a minimal level of pressure within the compressor. Refer to paragraph 2.2 for valve setting.

The following procedure can be used to perform a functional check:

- Install a high pressure gauge at the discharge service valve.
- Install another high pressure gauge at the liquid line service valve.
- Run unit with -18°C (0°F) set point.
- After five minutes, read both gauges and subtract the liquid line pressure from the discharge pressure. This is the actual differential pressure.
- Using the ambient temperature and the chart below, determine the replacement differential pressure.

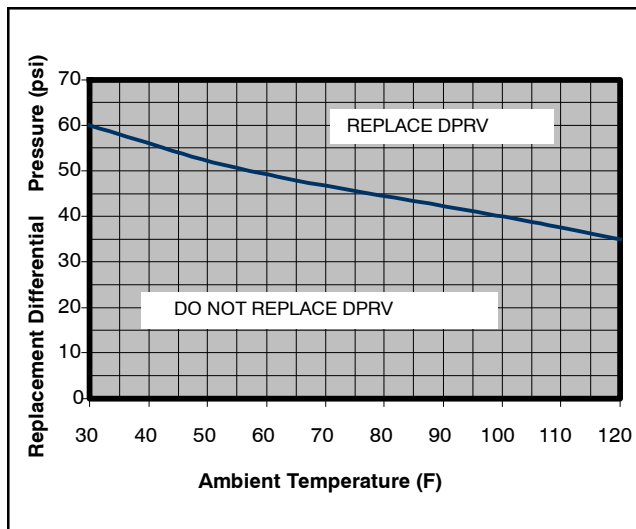

Figure 6-26 DPRV Replacement Value Chart

NOTE

- This test should not be run below -1.1°C (30°F) or above 49°C (120°F). If the actual differential pressure is close to the replacement differential pressure, it is recommended that the readings be taken several times at two minutes intervals.
- If valve cap is found to be leaking it may be replaced using cap & O-ring (Carrier Part Number 40-50024-00).

6.21 AUTOTRANSFORMER

If the unit does not start, check the following:

- Make sure the 460VAC (yellow) power cable is plugged into the receptacle (item 3, Figure 4-1) and locked in place.
- Make sure that circuit breakers CB-1 and CB-2 are in the "ON" position. If the circuit breakers do not hold in, check voltage supply.
- There is no internal protector for this transformer design; therefore, no checking of the internal protector is required.
- Using a voltmeter and with the primary supply circuit ON, check the primary (input) voltage (460VAC). Next, check the secondary (output) voltage (230VAC). The transformer is defective if output voltage is not available.

6.22 CONTROLLER

6.22.1 Handling Controller

 **CAUTION**

Do not remove wire harnesses from controller unless you are grounded to the unit frame with a static safe wrist strap.

 **CAUTION**

Unplug all controller connectors before performing arc welding on any part of the container.

The guidelines and cautions provided herein should be followed when handling the Controller/DataCORDER module. These precautions and procedures should be implemented when replacing the module, when doing any arc welding on the unit, or when service to the refrigeration unit requires handling and removal of the controller.

Figure 6-27 Controller Section of the Control Box

- Obtain a grounding wrist strap (Carrier Transicold PN 07-00304-00) and a static dissipation mat (Carrier Transicold PN 07-00304-00). The wrist strap, when properly grounded, will dissipate any potential build-up on the body. The dissipation mat will provide a static-free work surface on which to place and/or service the controller.
- Disconnect and secure power to the unit.
- Place strap on wrist and attach the ground end to any exposed unpainted metal area on the refrigeration unit frame (bolts, screws, etc.).
- Carefully remove the controller. Do not touch any of the electrical connections if possible. Place the module on the static mat.
- The strap should be worn during any service work on the controller, even when it is placed on the mat.

6.22.2 Controller Troubleshooting

A group of test points (TP) (see Figure 6-27) are provided on the controller for troubleshooting electrical circuits (see schematic diagram, section 7). A description of the test points follows:

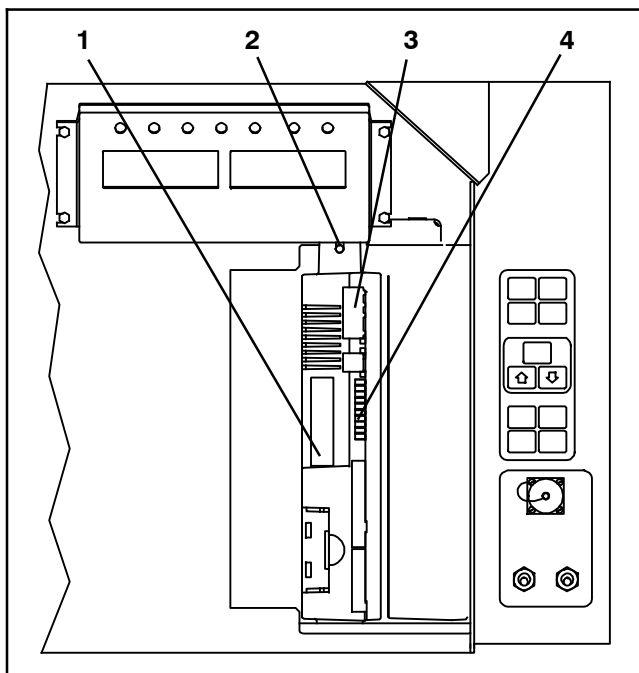

- | | |
|---|----------------|
| 1. Controller Software Programming Port | 3. Controller |
| 2. Mounting Screw | 4. Test Points |

NOTE

Use a digital voltmeter to measure AC voltage between TPs and ground (TP9), except for TP8.

TP2

This test point enables the user to check if the internal protector for the compressor motor (IP-CP) or high pressure switch is open.

TP3

This test point enables the user to check if the water pressure switch (WP) contact is open or closed.

TP 4

This test point enables the user to check if the internal protector for the condenser fan motor (IP-CM) is open or closed.

TP 5

This test point enables the user to check if the internal protectors for the evaporator fan motors (IP-EM1 or IP-EM2) are open or closed.

TP 6

This test point enables the user to check if the controller water tank heater relay (TQ) is open or closed.

TP 7

This test point is not used in this application.

TP 8

This test point is not applicable to the units covered herein.

TP 9

This test point is the chassis (unit frame) ground connection.

TP 10

This test point enables the user to check if the heat termination thermostat (HTT) contact is open or closed.

6.22.3 Controller Programming Procedure

To load new software into the module, the programming card (PCMIA) is inserted into the programming/software port.



CAUTION

The unit must be OFF whenever a programming card is inserted or removed from the controller programming port.

- a. Procedure for loading operational software
 1. Turn unit OFF via start-stop switch (ST).
 2. Insert software/programming card containing the following (example) files into the programming/software port (see Figure 6-27):
 - menuDDMM.m13* - This file allows the user to select a file/program to upload into the controller.
 - cfYYMMDD.m13* - Multi-configuration file.
 3. Turn unit ON via start-stop switch (ST).
 4. The display module will display the message ruN COnFG. If a defective card is being used, the display will blink the message "bAd CARd." Turn start-stop switch OFF and remove the card.
 5. Press the UP or DOWN arrow key until display reads, LOAd 51XX for Recip.
 6. Press the ENTER key on the keypad. The display will alternate to between PrESS EntR and rEV XXXX.
 7. Press the ENTER key on the keypad.
 8. The display will show the message "Pro SoFt". This message will last for up to one minute.
 9. Press the ENTER key on the keypad.
 10. The display module will go blank briefly, then read "Pro donE" when the software is loaded. If a problem occurs while loading the software, the display will blink the message "Pro FAIL" or "bad 12V." Turn start-stop switch OFF and remove the card.
 11. Turn unit OFF via start-stop switch (ST).
 12. Remove the programming card from the programming/software port and return the unit to normal operation by placing the start-stop switch in the ON position.
 13. Turn power on and wait 15 seconds. The status LED will flash quickly and there will be no display. The controller is loading the new software into memory. This takes about 15 seconds.

When complete the controller will reset and power up normally.

14 Wait for default display – setpoint on the left and control temperature on the right.

15. Confirm software is correct using keypad code select 18 to view Cd18 XXXX.

16. Turn power off. Operational software is loaded.

b. Procedure for loading configuration software:

1. Turn unit OFF using start-stop switch (ST).
2. Insert software/programming PCMCIA card containing the following (example) files into the programming/software port (see Figure 6-27):

menuDDMM.ml3 – This file allows the user to select the file/program to upload into the controller.

cfYYMMDD.ml3 – Multi-configuration file.

recp51XX.ml3 – Controller software program for recip units.

3. Turn unit ON using start-stop switch (ST).
4. The display module will display the message ruN COnFG. If a defective card is being used, the display will blink the message “bAd CArd.” Turn start-stop switch OFF and remove the card.
5. Press the ENTER key on the keypad.
6. The display module will go blank briefly and then display “541 00.” Based on the operational software installed.
7. Press the UP or DOWN ARROW key to scroll through the list to obtain the proper model dash number. (If a defective card is being used, the display will blink the message “bAd CArd.” Turn start-stop switch OFF and remove the card.)
8. Press the ENTER key on the keypad.
9. When the software loading has successfully completed, the display will show the message “EEPPrM donE.” (If a problem occurs while loading the software, the display will blink the message “Pro FAIL” or “bad 12V.” Turn start-stop switch OFF and remove the card.)
10. Turn unit OFF using start-stop switch (ST).
11. Remove the programming card from the programming/software port and return the unit to normal operation by placing the start-stop switch in the ON position.
12. Confirm correct model configuration using the keypad to choose code select 20 (CD20). The model displayed should match the unit serial number plate.

6.22.4 Removing and Installing the Controller

a. Removal:

1. Disconnect all front wire harness connectors and move wiring out of way.
2. The lower controller mounting is slotted. Loosen the top mounting screw (see Figure 6-27) and lift up and out.
3. Disconnect the two back connectors (EC) and remove module.
4. When removing the replacement controller from its packaging, note how it is packaged. When returning the old controller for service, place it in the packaging in the same manner as the replacement. The pack-

aging has been designed to protect the controller from both physical and electrostatic discharge damage during storage and transit.

b. Installation:

Install the module by reversing the removal steps.

Torque values for mounting screws (item 2, see Figure 6-27) are 0.23mkg (20 inch-pounds). Torque value for the connectors is 0.12mkg (10 inch-pounds).

6.22.5 Battery Replacement

If required, use tool 07-00418-00.

6.23 TEMPERATURE SENSOR SERVICE

Procedures for service of the Return Recorder, Return Temperature, Supply Recorder, Supply Temperature, Ambient, Defrost Temperature, Compressor Discharge and Compressor Suction temperature sensors are provided in the following sub paragraphs.

6.23.1 Sensor Checkout Procedure

To check a sensor reading, do the following:

- a. Remove the sensor and place in a 0°C (32°F) ice-water bath. The ice-water bath is prepared by filling an insulated container (of sufficient size to completely immerse bulb) with ice cubes or chipped ice, then filling voids between ice with water and agitating until mixture reaches 0°C (32°F) measured on a laboratory thermometer.
- b. Start unit and check sensor reading on the control panel. The reading should be 0°C (32°F). If the reading is correct, reinstall sensor; if it is not, continue with the following:
- c. Turn unit OFF and disconnect power supply.
- d. Refer to paragraph 6.22 and remove controller to gain access to the sensor plugs.
- e. Using the plug connector marked “EC,” that is connected to the back of the controller, locate the sensor wires (RRS, RTS, SRS, STS, AMBS, DTS, CPDS OR CPSS as required). Follow those wires to the connector and using the pins of the plug, measure the resistance. Values are provided in Table 6-1.

Table 6-1 Sensor Temperature/Resistance Chart

Temperature Centigrade	Temperature Fahrenheit	Resistance (Ohms)
RRS, RTS, SRS and STS:		
0	32	32,650 +/-91
25	77	10,000 +/-50
AMBS and DTS		
0	32	32,650 + 1720 - 1620
25	77	10,000 + 450 - 430

Due to the variations and inaccuracies in ohmmeters, thermometers, or other test equipment, a reading within 2% of the chart value would indicate a good sensor. If a sensor is defective, the resistance reading will usually be much higher or lower than the resistance values given.

6.23.2 Sensor Replacement

- Turn unit power OFF and disconnect power supply.
- For two wire sensors, cut cable 5cm (2 inches) from shoulder of defective sensor and discard the defective sensor only. For 3-wire sensors, cut at 23cm (9 inches). Slide the cap and grommet off well mounted sensor and save for possible reuse. **Do not cut the grommet.**
- If required, prepare the replacement sensor by cutting sensor wire(s) back 40mm (1-1/2 inch). For 3-wire sensors, the black wire should be cut at the middle length and the red/white wire cut to the shorter length (See Figure 6-28).
- Prepare the cables by cutting wires to the opposite of the sensor (See Figure 6-29).

When installing a single wire color two wire sensor, cut one wire of existing two wire cable 40 mm (1-1/2 inch) shorter than the other wire.

When replacing two single sensors with a combination (3-wire) sensor, the black wires of the cables should be cut to the same length and the red wire of one cable cut to the shorter length.

When replacing a original 3-wire sensor, cut the black wire to the middle length and the red wire to the shorter length.

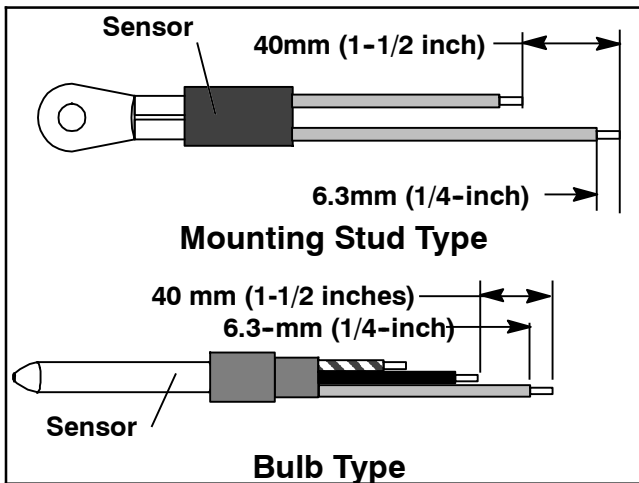

Figure 6-28 Sensor Types

- Strip back insulation on all wiring 6.3mm (1/4-inch).
- Slide a large piece of heat shrink tubing over the cable, and place small pieces of heat shrink tubing, one over each wire, before adding crimp fittings as shown in Figure 6-29.
- If required, slide the cap and grommet assembly onto the replacement sensor. If the replacement sensor is of a larger diameter than the original, a different grommet may be required.
- Slip crimp fittings over dressed wires (keeping wire colors together). Make sure wires are pushed into crimp fittings as far as possible and crimp with crimping tool.
- Solder spliced wires with a 60% tin and 40% lead Rosincore solder.
- Slide heat shrink tubing over splice so that ends of tubing cover both ends of crimp as shown in Figure 6-29.
- Heat tubing to shrink over splice. Make sure all seams are sealed tightly against the wiring to prevent moisture seepage.
- Slide large heat shrink tubing over both splices and shrink.

CAUTION

Do not allow moisture to enter wire splice area as this may affect the sensor resistance.

- Reinstall sensor, refer to paragraph 6.23.3.

NOTE

The P5 Pre-Trip test must be run to inactivate probe alarms (refer to paragraph 4.8).

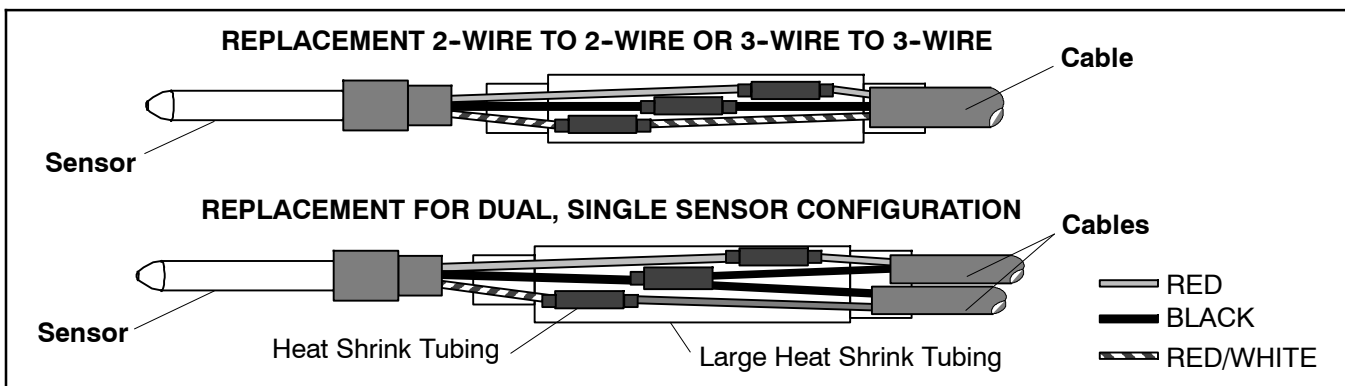

Figure 6-29 Sensor and Cable Splice

6.23.3 Sensor Re-Installation

a. Sensors RTS/RRS

To properly position a return sensor, the sensor must be fully inserted into the probe holder. This positioning will give the sensor the optimum amount of exposure to the return air stream, and will allow the Controller to operate correctly. Insufficient probe insertion into the probe holder will result in poor temperature control due to the lack of air flow over the sensor.

It is also necessary to ensure that the probe tip does not contact the evaporator back panel. The design minimum clearance of 6mm (1/4-inch) should be maintained (see Figure 6-30).

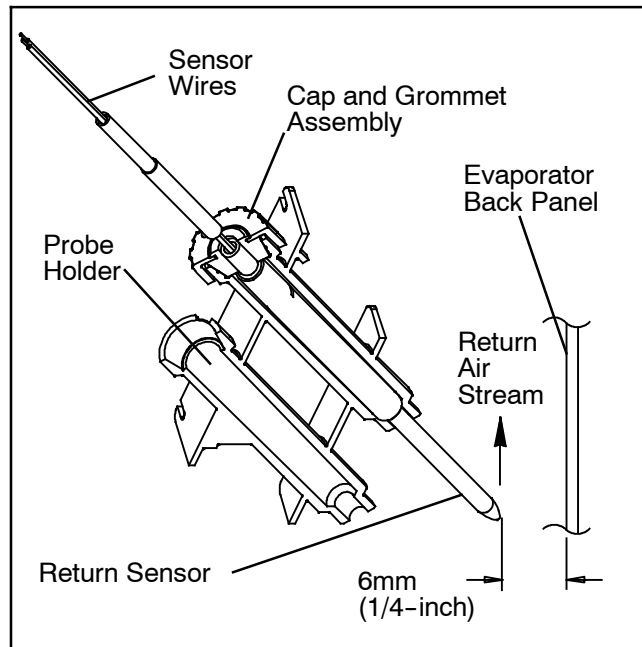

Figure 6-30 Return Sensor Positioning

b. Sensor STS/SRS

Reinstall the supply sensor as shown in Figure 6-31. For proper placement of the supply sensor, be sure to position the seal section of the sensor against the side of the mounting clamp.

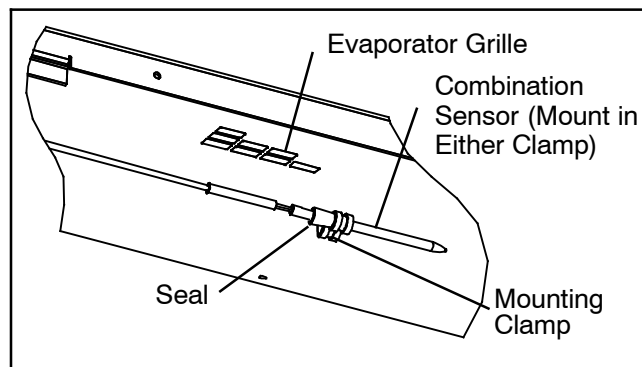

Figure 6-31 Supply Sensor Positioning

c. Sensor DTS

The DTS sensor must have insulating material placed completely over the sensor to insure the coil metal temperature is sensed.

6.24 VENT POSITION SENSOR (VPS)

The vent position sensor (VPS) determines the position of the fresh air vent in near real-time via the function code 55.

The fresh air VPS alarm (AL50) will occur if the sensor reading is not stable for five minutes or if the sensor is outside of its valid range (shorted or open). This can occur if the vent is loose or the panel is defective. To confirm a defective panel, assure that the wing nut is secure and then power cycle the unit.

The alarm should immediately go inactive. Check the four-minute stability requirement. If the alarm reoccurs after the four minutes and the panel was known to have been stable, then the panel should be replaced.

If the alarm immediately reappears as active, the panel should be replaced.

Upper VPS:

In order to replace the VPS, the panel must be removed and replaced with another upper fresh air panel equipped with VPS.

Upon installation, a new VPS assembly requires calibration as follows:

1. Rotate the vent to the 0 CMH/ CFM position.
2. Code select 45 will automatically be displayed. Press the Enter key and hold for five seconds.
3. After the enter key has been pressed, the display will read CAL (for calibration).
4. Press the ALT MODE key and hold for five seconds.
5. After the calibration has been completed, Code 45 will display 0CMH / CFM.
6. Calibrate sensor:
 - a. Use a multi-meter set to 200k ohms. Connect lead to VPS connector.
 - b. Turn the gear wheel on the motor all the way to the right (clockwise) until it stops.
 - c. Adjust the gear wheel counter clockwise until the meter reads *6.5k ohms* (approximately).
 - d. Install the VPS slide door so that the door is flush against the bottom rail, the motor gear and the door teeth are meshed, and the gear wheel does not move from the set position.
7. Position slide assembly back on to studs and re-install two washers and two nuts that secure slide assembly.
8. Stake the ends of the two studs on panel assembly with wire cutters so that nuts will not be easily removed.
9. Reinstall Partlow box assembly if equipped, or access panel.
10. Reinstall condenser fan guard.

If the optional DataCORDER battery pack is being used and the charge is too low to enable recording during the power off period of less than thirty days, the pen tip will move to below the inner chart ring for the period when NO data was recorded by the DataCORDER.

If the power has been OFF for more than thirty days, the recorder will NOT re-synchronize (the chart will not advance to present time), the pen tip will move to the currently recorded temperature, and the recorder will resume normal temperature recording.

6.25 ELECTRONIC TEMPERATURE RECORDER

The microprocessor based temperature recorder is designed to interface with the DataCORDER to log temperature with time. The electronic recorder will automatically record the return air, supply air, or both, based on the setting of temperature controller configuration code CnF37, refer to Table 3-4. The recorder reads and records data from the Controller in present time, under normal operating conditions.

The recorder will STOP when the power is OFF, and the pen tip will remain at the last recorded temperature on the chart. When power is applied and the power off period is less than thirty days, the recorder will retrieve the logged data from the DataCORDER for the power off period and record it onto the chart. Thereafter, the recorder will resume normal temperature recording.

If the optional DataCORDER battery pack is being used and the charge is too low to enable recording during the power off period of less than thirty days, the pen tip will move to below the inner chart ring for the period when NO data was recorded by the DataCORDER.

If the power has been OFF for more than thirty days, the recorder will NOT re-synchronize (the chart will not advance to present time), the pen tip will move to the currently recorded temperature, and the recorder will resume normal temperature recording.

6.25.1 Replacing the Recorder

- a. Turn power to the unit OFF.
- b. Open the recorder door (see Figure 6-32, item 1).
- c. Locate the connector below the recorder, and squeeze the ears together to disconnect the plug (item 6).
- d. Remove the four mounting screws (item 8) and remove the recorder.
- e. Install the new recorder by reversing the above steps.

6.25.2 Changing the Chart

NOTE

To prevent recorder corrosion, it is important to assure the door is securely closed at all times after completing the chart change.

- a. Lift the stylus (item 5, Figure 6-32) by grasping the arm near the base, and pulling the arm away from the chart until it snaps into its retracted position.
- b. Remove the chart retaining nut (item 10), remove the used chart, and record today's date on the old chart.
- c. Press the "Change Chart" button (item 2).

NOTE

Failure to press the change chart button when changing a chart with the power OFF may result in the chart advancing when power is applied.

- d. Install a new chart. Make sure the chart center hole is placed over the center hub and the chart edges are behind the four hold down tabs (item 9).
- e. Mark today's date, container number, and other required information on the new chart and install under hold down tabs.
- f. Replace the chart nut loosely. Rotate the chart until the correct day is aligned with the "start arrow" and hand tighten the chart nut.
- g. Gently lower the stylus arm until the pen tip (item 4) comes in contact with the chart.



CAUTION

Do not allow the recorder stylus to snap back down. The stylus arm base is spring loaded, and damage may occur to the chart, or the stylus force may be altered.

DO NOT move the stylus arm up and down on the chart face. This will result in damage to the stylus motor gear.

6.25.3 Rezeroing the Recording Thermometer

NOTE

Use chart CTD P/N 09-00128-00 (°F)

Use chart CTD P/N 09-00128-01 (°C)

- a. Press the "Calibration" button (item 7, Figure 6-32) on the bottom of the recorder. The pen tip will drive fully down scale, then move upscale to the chart ring at 0° degrees C (32° degrees F), and stop.
- b. If the tip of the pen (item 4) is on the 0°C (32°F) chart ring the recorder is in calibration, proceed to step c. If the tip of the pen is NOT on the 0°C (32°F) chart ring, the operator must loosen the two screws on the bottom of the stylus arm to adjust the pen tip manually to the 0°C (32°F) chart ring. Tighten the screws when adjustment is complete.
- c. Press the calibration button and the pen will position itself to the correct temperature reading.

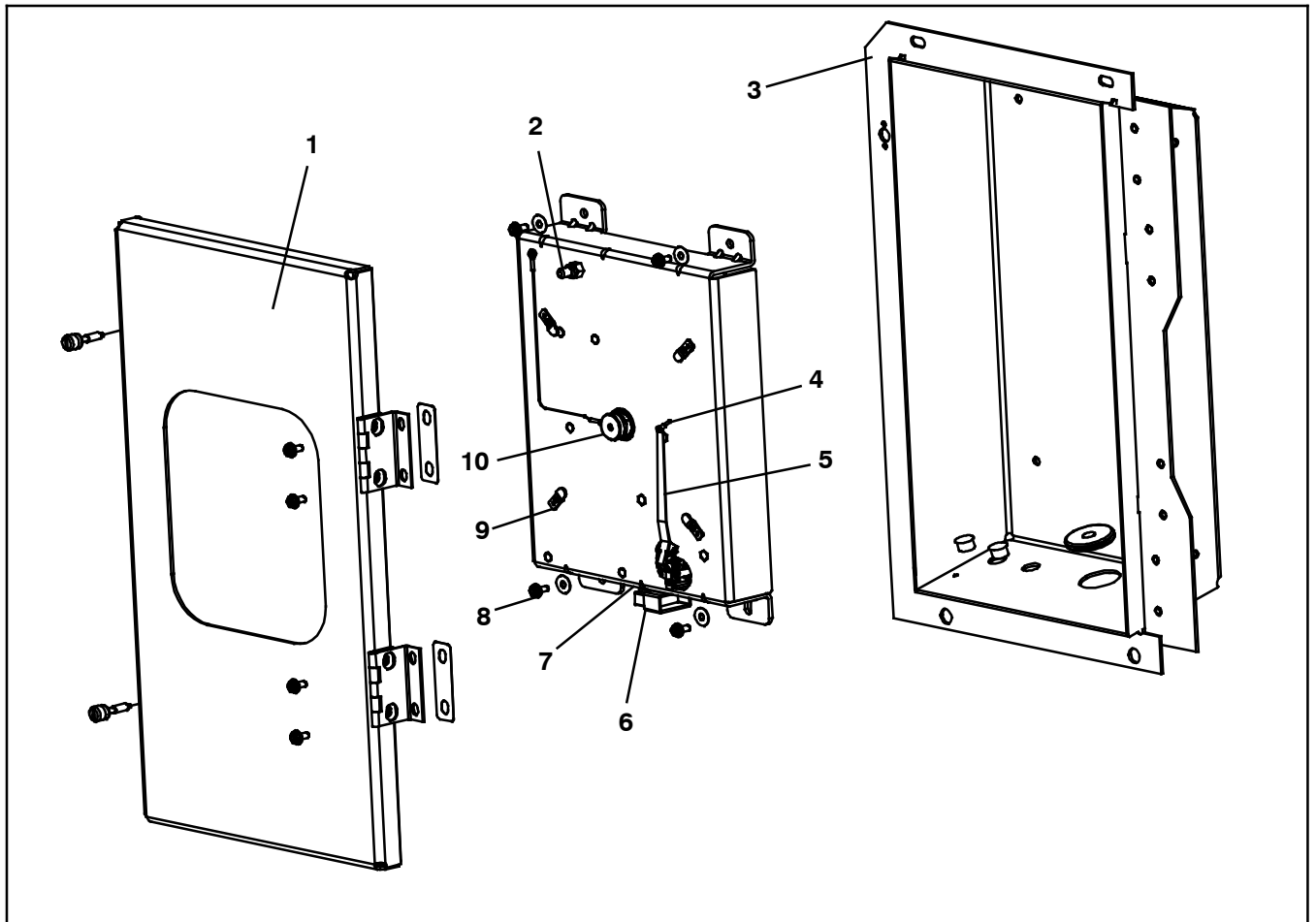

- | | |
|------------------------|---|
| 1. Recorder Door | 6. Connector |
| 2. Change Chart Button | 7. Calibration Button (Located underneath) |
| 3. Recorder Box | 8. Mounting Screws, #10-24 x 7/16 inches long |
| 4. Pen Tip | 9. Hold Down Tab |
| 5. Stylus Arm | 10. Chart Retaining Nut |

Figure 6-32 Electronic Partlow Temperature Recorder

6.26 MAINTENANCE OF PAINTED SURFACES

The refrigeration unit is protected by a special paint system against the corrosive atmosphere in which it normally operates. However, should the paint system be damaged, the base metal can corrode. In order to protect the refrigeration unit from the highly corrosive sea atmosphere or if the protective paint system is scratched or damaged, clean area to bare metal using a wire brush, emery paper, or equivalent cleaning method. Immediately following cleaning, spray or brush on zinc-rich primer. After the primer has dried, spray or brush on finish coat of paint to match original unit color.

6.27 COMPOSITE CONTROL BOX REPAIRS

6.27.1 Introduction

This procedure provides instructions for repair of the Carrier Transicold composite control box. Damage to the control box may be in the form of a chip or hole, a crack, a damaged thread insert or damage to the door hinge inserts. Generally, the object of the repair must be to ensure sufficient strength is restored to the damaged area and the repair must keep the box water tight. Information on repair kits and repair procedures for each type of damage is provided in the following paragraphs. Ambient temperature must be above 7°C (45°F) for proper curing of epoxy repairs.

6.27.2 Cracks

Cracks in the control box are repaired using a fiberglass patch over the damaged area. Materials required are included in the Fiberglass Patch Kit supplied with Crack Repair Kit, Carrier Transicold part number 76-00724-00SV (see Table 6-2).

- a. The surface must be clean and dry. Roughen the surface with sandpaper to ensure a good bond.
- b. Cut the fiberglass cloth to allow a 25mm (1 inch) overlap around the area to be repaired.
- c. Stretch and position the cloth over the area to be repaired and secure it with masking tape.
- d. Make up sufficient epoxy glue to cover the cloth by mixing equal parts of resin and hardener. Saturate the cloth with the epoxy glue, spreading evenly.
- e. Remove the tape and overlap the edge of the cloth approximately 6 to 12mm (1/4" to 1/2") with glue.
- f. Epoxy will dry in 45-60 minutes. When completely cured (12 hours), use sandpaper to smooth edges of the patch.

6.27.3 Chips and Holes

Chips and holes in the control box are repaired using a piece of aluminum or stainless steel to cover the damaged area. The material can be cut to suit and riveted in place. An adhesive sealant must be used to make the repair watertight. The adhesive sealant (Sikaflex 221) is included in Crack Repair Kit Carrier Transicold part number 76-00724-00SV (see Table 6-2). **Do not use an acetone based silicone sealant**, which can be identified by a vinegar-like odor.

- a. To make up the patch, cut a piece of aluminum or stainless steel so that it will overlap the damaged area by at least 40mm (1-1/2") on all sides.
- b. Choose rivet locations and drill the rivet holes in the corresponding locations on the control box and patch piece.
- c. Apply the adhesive sealant around the damaged area to form a seal between the control box and the patch piece.
- d. Rivet the patch piece in place.
- e. File smooth any rough edges (including rivets) that may come into contact with wires.

6.27.4 Inserts

The threaded brass inserts that are molded into the control box will need to be replaced if the threads become stripped or if the insert becomes loose. The inserts and epoxy are contained in repair kit, Carrier Transicold part number 76-50084-00 (see Table 6-3). There are 6 different inserts used in the control box. Refer to Figure 6-34 for the locations of the various inserts.

NOTE

An epoxy application gun is also needed, Carrier Transicold part number 07-00391-00.

The damaged insert must be removed from the control box. Table 6-4 identifies the drill size and drill depth to be used for each insert. A stop ring should be used on the drill bit to limit the depth.

- a. Center the drill bit on the insert and drill to the prescribed depth.
- b. Remove the chips from the drilled hole.
- c. Mix the two component epoxy and fill the hole halfway to the top with epoxy.
- d. Press the insert in until it is flush with the surface.
- e. Wipe away any excess epoxy. The part is ready for service after the bond material has hardened and is tack free (approximately 20 minutes).

6.27.5 Door Hinge Inserts

If the door hinges have been pulled from the control box, drill and reinstall the hinge as shown in Figure 6-33 and described in the following steps:

Materials needed:

1. Cut two square pieces of 3mm thick (1/8-inch) aluminum or stainless steel approximately 40mm (1-5/8") square. These squares will serve as backing plates.
2. Two nuts, bolts (10-24 x 1") and washers for each insert that needs repair.
 - a. Drill a 1/4" hole in the center of each square backing plate.
 - b. Pass the bolts through the bolts holes in the door hinge, then through the control box at the location where the hinge insert pulled out.
 - c. From inside the control box, slide the backing plates over the bolts and secure in place with the washers and nuts.

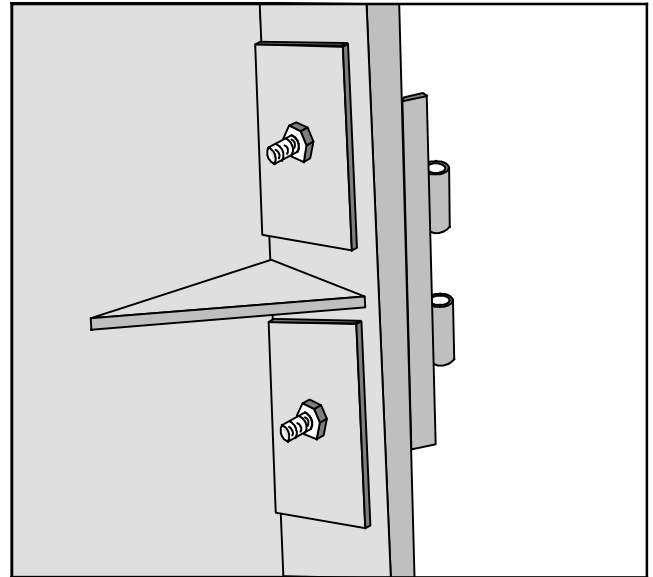

Figure 6-33 Door Hinge Repair

Table 6-2 Crack, Chip and Hole Repair Kit

ITEM	DESCRIPTION	PART NUMBER	Qty
1	Crack Repair Kit - Includes	76-00724-00SV	1
2	... Fiberglass Patch Kit (Loctite FK-98 or 80265)	76-00724-00Z	10
3	... Sikaflex 221 Adhesive Sealant (Sikaflex 232-361)	02-00067-02Z	10
4	... Instruction Sheet	98-02339-00	10

Table 6-3 Insert Repair Kit

ITEM	DESCRIPTION	PART NUMBER	Qty
1	Insert Repair Kit - Includes	76-50084-00	1
2	... Insert - 17.53 x 9.91mm (.690 x .390in) 1/4-20 Threads	34-06231-01	10
3	... Insert - 15.88 x 6.35mm (.625 x .250in) 10-24 Threads	34-06231-03	10
4	... Insert - 25.15 x 7.54mm (.990 x .297in) 10-24 Threads	34-06231-04	10
5	... Insert - 10.16 x 9.53mm (.400 x .375in) 10-24 Threads	34-06231-05	10
6	... Insert - 12.7 x 9.91mm (.5 x .390in) 1/4-20 Threads	34-06231-06	10
7	... Insert - 9.53 x 6.76mm (.375 x .266in) 10-24 Threads	34-06231-07	10
8	... Durabond Epoxy E20-HP (Loctite 29314)	02-00082-00	1
9	... Static Mixing Tube (Loctite 983440)	07-00390-00	1
10	... Instruction Sheet	98-02338-00	1

Note: Insert repair procedures require use of an Application Gun, Carrier part number 07-00391-00 (Loctite 983435).

Table 6-4 Drill Information

ITEM	INSERT PART NUMBER	DRILL SIZE AND DEPTH
1	34- 06231- 01	10.3mm x 17.8mm deep (.404in. x .700in. deep)
2	34- 06231- 03	6.8mm x 16.3mm deep (.266in. x .640in. deep)
3	34- 06231- 04	7.9mm x 25.4mm deep (.3125in. x 1.0in. deep)
4	34- 06231- 05	6.9mm (.270in.) Drill completely through.
5	34- 06231- 06	10.3mm (.404in.) Drill completely through.
6	34- 06231- 07	6.8mm (.266in.) Drill completely through.

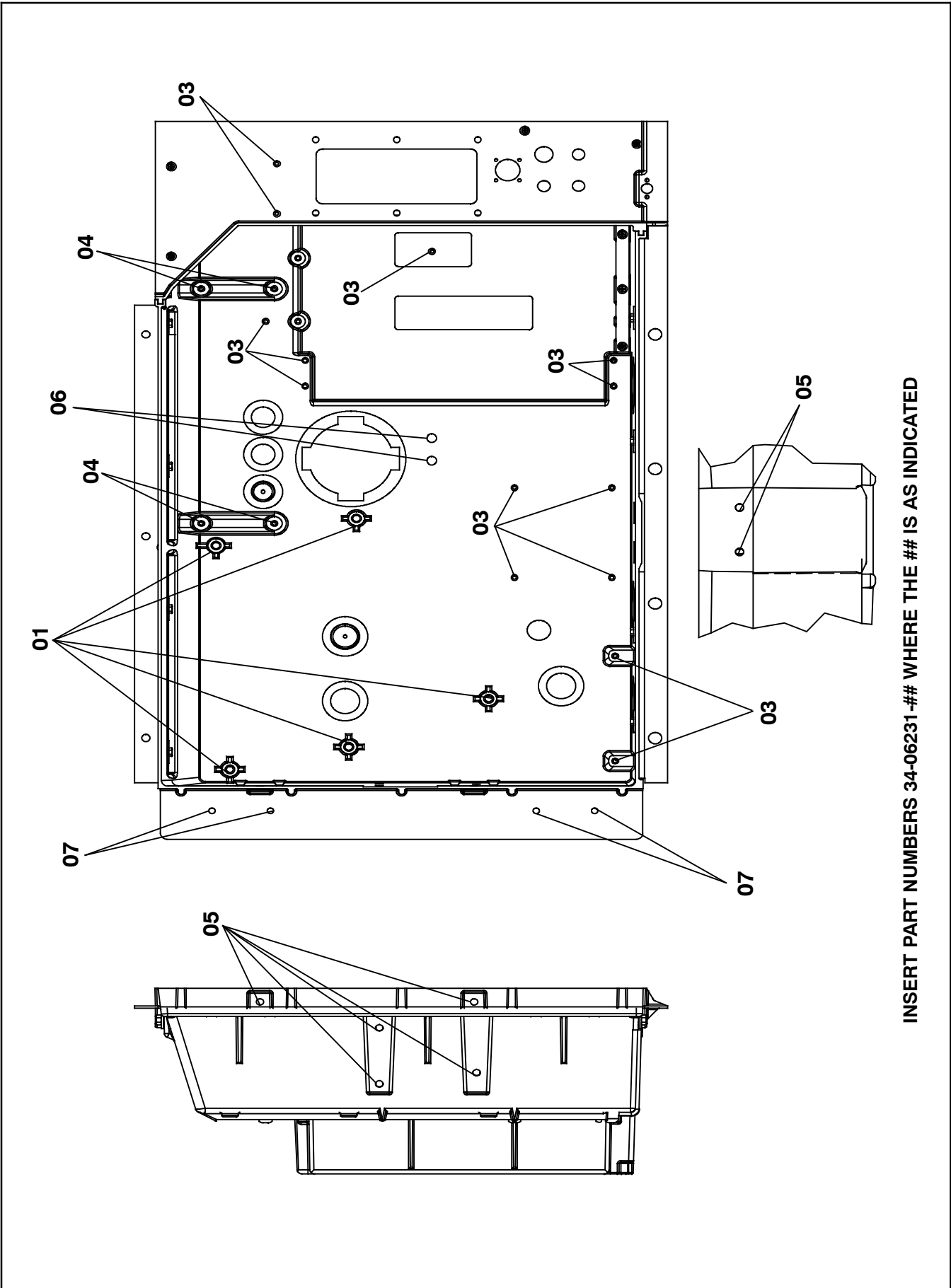

INSERT PART NUMBERS 34-06231-## WHERE THE ## IS AS INDICATED

Figure 6-34 Insert Location

6.28 COMMUNICATIONS INTERFACE MODULE INSTALLATION

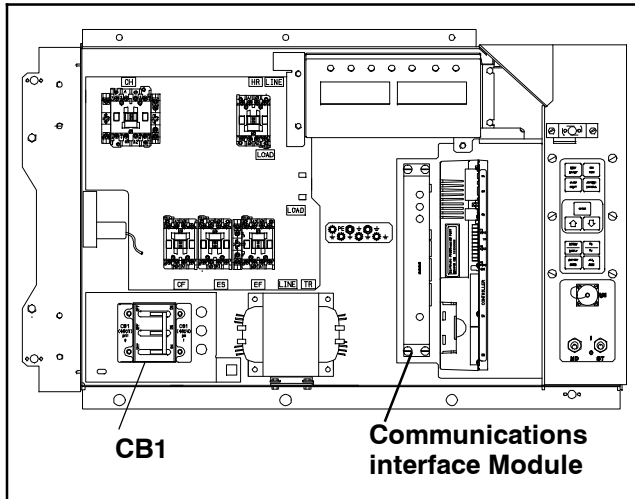

Figure 6-35 Communications Interface Installation

Units with communication interface module provision have the required wiring installed. The provision wiring kit (part number 76-00685-00), includes three pre-addressed wires installed between the circuit breaker and communication interface module locations. These wires are to be connected to the module and circuit breaker to allow the module to communicate over the power system. To install the module, do the following:

WARNING

The unit power plug must be disconnected to remove power from circuit breaker CB1

- CB1 is connected to the power system, see wiring schematic. Ensure that the unit power is off AND that the unit power plug is disconnected.
- Open control box, see Figure 6-35 and remove low voltage shield. Open high voltage shield.
- Remove the circuit breaker panel, with circuit breaker, from the control box.
- Locate wires CB21 / CIA3, CB22 / CIA5 and CB23 / CIA7 that have been tied back in the wire harness. Remove the protective heat shrink from the ends of the wires.
- Attach the three wires as addressed to the LOAD side of the circuit breaker.
- Refit the circuit breaker panel.
- Fit the new RMU into the unit.
- Remove plugs CIA, CIB and CID from the wiring harness and attach to the module.
- Replace the low voltage shield.

6.29 POWER FACTOR CORRECTOR CAPACITORS (PFC)

The power factor corrector capacitors are of the permanent-split capacitor type. There are a total of three capacitors with discharge resistors enclosed in a single case.

a. When to check for a defective capacitor

The capacitors assist in correcting current draw by the compressor. If one or more of the capacitors is faulty, there will be an imbalance in current. In addition, the power consumption of the unit will increase.

b. Removing the capacitor

WARNING

Make sure power to the unit is OFF and power plug disconnected before removing capacitor(s).

WARNING

Before removing the capacitors the terminals must be checked for voltage with a multimeter. The discharge resistors installed on the unit (capacitors) should bring the voltage to a safe level in a minute. However, there may be a broken resistor that retains voltage for a longer period, it is highly recommended to wait 15 minutes and to check for voltage.

If the capacitors require discharging, first, turn the unit power OFF and disconnect the unit power plug. Then, place a 20,000 ohm, 2 watt resistor across the terminals of the capacitor for approximately 30 seconds.

1. The capacitors are located on the unit sidewall above the evaporator fan deck and may be removed by two methods:

- If container is empty** – Open upper rear panel of the unit. The capacitors will be on the right and may be serviced after checking discharge.
- If container is full** – Remove the upper fresh air makeup vent.

c. Checking the capacitor

If the capacitor is suspected of malfunction, you may choose to simply replace it. Direct replacement requires a capacitor of the same value. Two methods for checking capacitor function are:

1. Volt-ohmmeter set on RX 10,000 ohms.

Connect ohmmeter leads across the capacitor terminals and observe the meter needle. If the capacitor is good, the needle will make a rapid swing toward zero resistance and then gradually swing back toward a very high resistance reading. The reading should read about 330,000 ohms (for a good capacitor) due to the discharge resistors.

If the capacitor has failed open, the ohmmeter needle will not move when the meter probes touch the terminals. If the capacitor is shorted, the needle will swing to zero resistance position and stay there.

2. Capacitor analyzer:

The function of the analyzer is to read the microfarad value of a capacitor and to detect insulation breakdown under load conditions. The important advantages of an analyzer are its ability to locate capacitors that have failed to hold their microfarad ratings, or those that are breaking down internally during operation. It is also useful in identifying capacitors when their microfarad rating marks have become unreadable.

Table 6-5 Recommended Bolt Torque Values

BOLT DIA.	THREADS	TORQUE	N.m
FREE SPINNING			
#4	40	5.2in-lbs	.6
#6	32	9.6in-lbs	1.0
#8	32	20in-lbs	2.25
#10	24	23in-lbs	2.6
1/4	20	75in-lbs	8.4
5/16	18	11ft-lbs	1.52
3/8	16	20ft-lbs	2.76
7/16	14	31ft-lbs	4.28
1/2	13	43ft-lbs	5.94
9/16	12	57ft-lbs	7.88
5/8	11	92ft-lbs	12.72
3/4	10	124ft-lbs	17.14
NONFREE SPINNING (LOCKNUTS ETC.)			
1/4	20	82.5in-lbs	9.3
5/16	18	145.2in-lbs	16.4
3/8	16	22.0ft-lbs	30
7/16	14	34.1ft-lbs	46
1/2	13	47.3ft-lbs	64
9/16	12	62.7ft-lbs	85
5/8	11	101.2ft-lbs	137
3/4	10	136.4ft-lbs	168

Table 6-6 Wear Limits For Compressors

PART NAME	FACTORY MAXIMUM		FACTORY MINIMUM		MAXIMUM WEAR BEFORE REPAIR	
	inches	mm	inches	mm	inches	mm
MAIN BEARING						
Main Bearing Diameter	1.6268	41.3207			.0020	0.0508
Main Bearing Journal Diameter			1.6233	41.2318	.0020	0.0508
PUMP END						
Main Bearing Diameter	1.3760	34.9504			.0020	0.0508
Main Bearing Journal Diameter			1.3735	34.8869	.0020	0.0508
CONNECTING ROD						
Piston Pin Bearing	1.3768	34.9707	0.6878	17.4701	.0010	0.0254
CRANKPIN DIAMETER			1.3735	34.8869	.0025	0.0635
Throw	1.072	27.2288	1.070	27.1780		
THRUST WASHER (Thickness)	0.154	3.9116	0.1520	03.8608	.0250	0.6350
CYLINDERS						
Bore	2.0010	50.8254			.0020	0.0508
Piston (Diameter)			1.9860	50.4444	.0020	0.0508
Piston Pin (Diameter)			0.6873	17.4574	.0010	0.0254
Piston Ring Gap	0.013	00.3302	0.0050	00.1270	.0250	0.6350
Piston Ring Side Clearance	0.002	00.0508	0.0010	00.0254	.0020	0.0508

Table 6-7 Compressor Torque Values

SIZE DIAMETER (inches)	THREADS PER INCH	TORQUE RANGE		USAGE
		ft-lb	N.m	
1/16	27 (pipe)	8 - 12	11 - 16	Pipe Plug - Crankshaft
1/8	20 (pipe)	6 - 10	8 - 13	Oil Return Check Valve - Crankcase
1/4	20 (pipe)	20 - 25	27 - 34	Pipe Plug - Gauge Connection
1/4	20	10 - 12	13 - 16	Connecting Rod cap screw
1/4	28	12 - 15	16 - 20	Baffle Plate - Crankcase
		12 - 16	16 - 22	Side Shield
		6 - 10	8 - 13	Oil Pump Drive Segment
		12 - 16	16 - 22	Unloader Valve
5/16	18	16 - 20	2 - 27	Cover Plate - Plate End
				Bearing Head
				Terminal Block Cap Screws
		20 - 30	27 - 41	Suction Valve
				Discharge Valve
3/8	16	40 - 50	55 - 70	Pump End Bearing Head
				Bottom Plate - Crankcase Compressor Foot
				Cylinder Head
7/16	14	55 - 60	76 - 83	Motor End Cover - Crankcase
5/8	11	25 - 30	34 - 41	Crankshaft
5/8	18	60 - 75	83 - 103	Oil Bypass Plug - Crankcase
#10	32	4 - 6	5 - 8	Oil Pump Drive Segment
1-1/2	18 NEF	35 - 45	48 - 62	Oil Level Sight Glass
NEF - National Extra Fine				

Table 6-8 R-134a Temperature - Pressure Chart

Temperature		Vacuum			
F	C	"/hg	cm/hg	kg/cm ²	bar
-40	-40	14.6	49.4	37.08	0.49
-35	-37	12.3	41.6	31.25	0.42
-30	-34	9.7	32.8	24.64	0.33
-25	-32	6.7	22.7	17.00	0.23
-20	-29	3.5	11.9	8.89	0.12
-18	-28	2.1	7.1	5.33	0.07
-16	-27	0.6	2.0	1.52	0.02
Temperature		Pressure			
F	C	psig	kPa	kg/cm ²	bar
-14	-26	0.4	1.1	0.03	0.03
-12	-24	1.2	8.3	0.08	0.08
-10	-23	2.0	13.8	0.14	0.14
-8	-22	2.9	20.0	0.20	0.20
-6	-21	3.7	25.5	0.26	0.26
-4	-20	4.6	31.7	0.32	0.32
-2	-19	5.6	36.6	0.39	0.39
0	-18	6.5	44.8	0.46	0.45
2	-17	7.6	52.4	0.53	0.52
4	-16	8.6	59.3	0.60	0.59
6	-14	9.7	66.9	0.68	0.67
8	-13	10.8	74.5	0.76	0.74
10	-12	12.0	82.7	0.84	0.83
12	-11	13.2	91.0	0.93	0.91
14	-10	14.5	100.0	1.02	1.00
16	-9	15.8	108.9	1.11	1.09
18	-8	17.1	117.9	1.20	1.18
20	-7	18.5	127.6	1.30	1.28
22	-6	19.9	137.2	1.40	1.37
24	-4	21.4	147.6	1.50	1.48
26	-3	22.9	157.9	1.61	1.58

Temperature		Pressure			
F	C	psig	kPa	kg/cm ²	bar
28	-2	24.5	168.9	1.72	1.69
30	-1	26.1	180.0	1.84	1.80
32	0	27.8	191.7	1.95	1.92
34	1	29.6	204.1	2.08	2.04
36	2	31.3	215.8	2.20	2.16
38	3	33.2	228.9	2.33	2.29
40	4	35.1	242.0	2.47	2.42
45	7	40.1	276.5	2.82	2.76
50	10	45.5	313.7	3.20	3.14
55	13	51.2	353.0	3.60	3.53
60	16	57.4	395.8	4.04	3.96
65	18	64.1	441.0	4.51	4.42
70	21	71.1	490.2	5.00	4.90
75	24	78.7	542.6	5.53	5.43
80	27	86.7	597.8	6.10	5.98
85	29	95.3	657.1	6.70	6.57
90	32	104.3	719.1	7.33	7.19
95	35	114.0	786.0	8.01	7.86
100	38	124.2	856.4	8.73	8.56
105	41	135.0	930.8	9.49	9.31
110	43	146.4	1009	10.29	10.09
115	46	158.4	1092	11.14	10.92
120	49	171.2	1180	12.04	11.80
125	52	184.6	1273	12.98	12.73
130	54	198.7	1370	13.97	13.70
135	57	213.6	1473	15.02	14.73
140	60	229.2	1580	16.11	15.80
145	63	245.6	1693	17.27	16.93
150	66	262.9	1813	18.48	18.13
155	68	281.1	1938	19.76	19.37

Note: Curves to be used as troubleshooting guide only for model series 69NT40 with fresh air makeup vent closed, unit powered on 460VAC/60Hz and SMV 100% open.

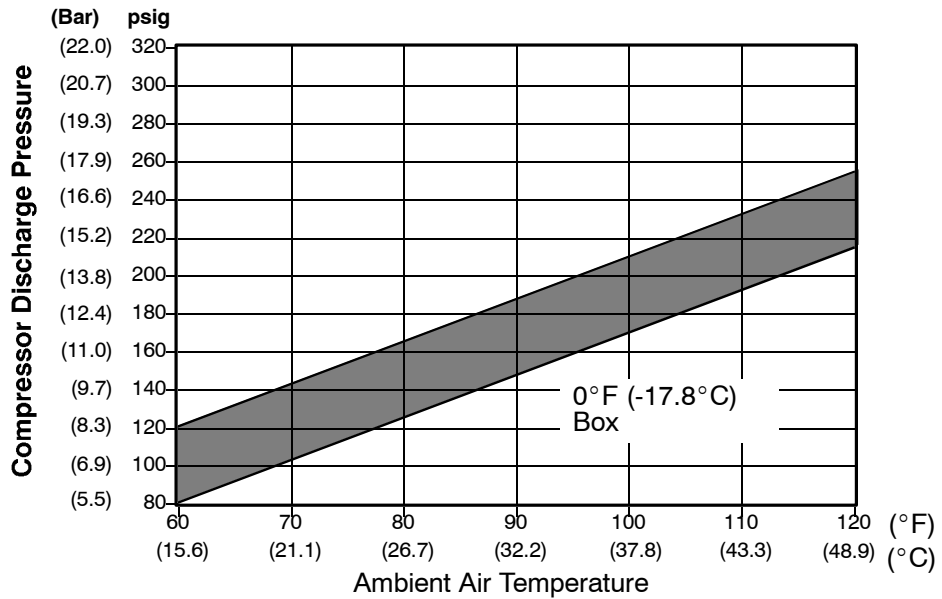
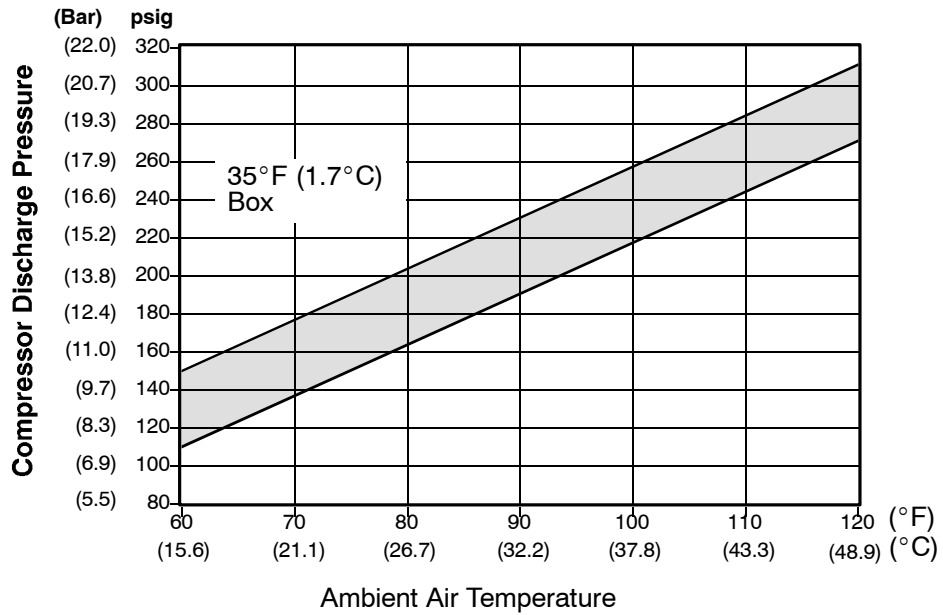

Compressor Discharge Pressure Versus Ambient Air Temperature at Stable Box Temperature

Figure 6-36 R-134a Compressor Pressure and Motor Current Curves Versus Ambient Temperature
(Sheet 1 of 2)

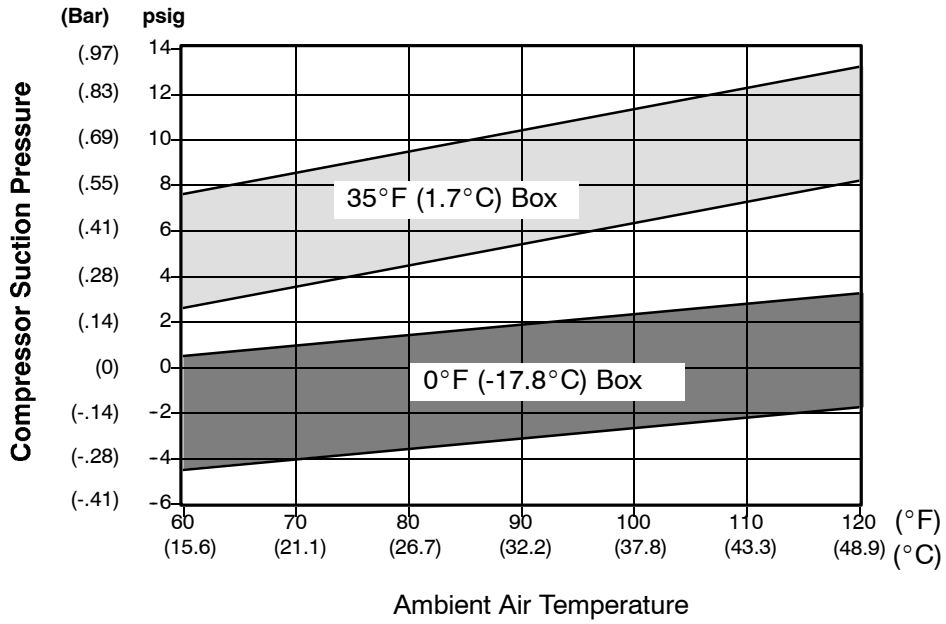

Compressor Suction Pressure Versus Ambient Air Temperature at Stable Box Temperature

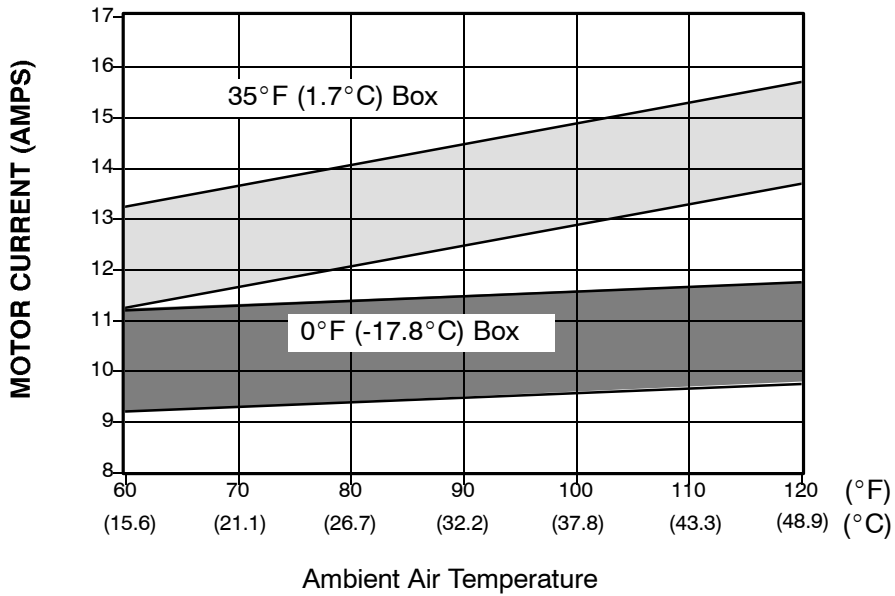

Compressor-Motor Current Versus Ambient Air Temperature At Stable Box Temperature

Figure 6-36 R-134a Compressor Pressure and Motor Current Curves Versus Ambient Temperature
(Sheet 2 of 2)

SECTION 7

ELECTRICAL WIRING SCHEMATICS

7.1 INTRODUCTION

This section contains **Electrical Schematic and Wiring Diagrams**, the diagrams are presented as follows:

Figure 7-1 provides the legend for use with all figures.

Figure 7-2 provides the basic schematic diagram for units with single evaporator fan capability and VPS.

Figure 7-3 & Figure 7-4 provide wiring diagrams for units with single evaporator fan capability and VPS.

Figure 7-5 provides the basic schematic diagram for units with normal evaporator fan capability, TransFresh and Crankcase Heater.

Figure 7-6 & Figure 7-7 provide wiring diagrams for units with normal evaporator fan capability, TransFresh and Crankcase Heater.

LEGEND	
SYMBOL	DESCRIPTION
AMBS	AMBIENT SENSOR (D-18)
C	CONTROLLER (C-16)
CB1	CIRCUIT BREAKER 460 VOLT (J-1)
CB2	OPTIONAL CIRCUIT BREAKER 230V (DVM OPTION) TERMINAL BLOCK WHEN CB2 NOT PRESENT (D-1)
CCH	CRANKCASE HEATER (T-4)
CF	CONDENSER FAN CONTACTOR (M-9, P-6)
CI	COMMUNICATIONS INTERFACE MODULE (OPTION) (A-4)
CH	COMPRESSOR CONTACTOR (L-8, P-1, P-3)
C - L	COOL LIGHT (OPTION) (L-11)
CM	CONDENSER FAN MOTOR (G-10, T-6)
CP	COMPRESSOR MOTOR (E-8, T-2)
CPDS	COMPRESSOR DISCHARGE SENSOR (TEMP.) (OPTION) (C-18)
CPSS	COMPRESSOR SUCTION SENSOR (TEMP.) (OPTION) (E-18)
CPT	CONDENSER PRESSURE TRANSDUCER (H-19)
CR	CHART RECORDER (OPTION) (A-14)
CS	CURRENT SENSOR (M-2)
DHBL	DEFROST HEATER - BOTTOM LEFT (R-4)
DHBR	DEFROST HEATER - BOTTOM RIGHT (T-4)
DHML	DEFROST HEATER - MIDDLE LEFT (R-4)
DHMR	DEFROST HEATER - MIDDLE RIGHT (T-4)
DHTL	DEFROST HEATER - TOP LEFT (R-3)
DHTR	DEFROST HEATER - TOP RIGHT (T-4)
DL	DEFROST LIGHT (OPTION) (M-14 / L-8)
DPT	DISCHARGE PRESSURE TRANSDUCER (OPTION) (K-19)
DTS	DEFROST TEMPERATURE SENSOR (D-18)
DVM	DUAL VOLTAGE MODULE (OPTION) (D-1)
DVR	DUAL VOLTAGE RECEPTACLE (OPTION) (F-2)
E	EVAPORATOR FAN CONTACTOR (HIGH SPEED) (G-11, H-12, J-10, K-11, P-7, P-10)
EM	EVAPORATOR FAN MOTOR (L-10, L-12, T-6, T-8)
S	EVAPORATOR FAN CONTACTOR (LOW SPEED) (G-10, H-11, J-11, K-12, R-8, R-11)
EF	EVAPORATOR FAN CONTACTOR (HIGH SPEED) (L-11, M-10, P-7, P-8)
EM	EVAPORATOR FAN MOTOR (D-11, F-11, T-8, T-10)
ES	EVAPORATOR FAN CONTACTOR (LOW SPEED) (M-11, R-7)
F	FUSE (C-8, D-8, E-16, F-16, H-6, G-16)
HPS	HIGH PRESSURE SWITCH (H-8)
HR	HEATER CONTACTOR (M-13, P-4)
HS	HUMIDITY SENSOR (G-19)
HTT	HEAT TERMINATION THERMOSTAT (H-12)
IC	INTERROGATOR CONNECTOR (OPTION) (T-19)
IP	INTERNAL PROTECTOR (E-8, G-9, M-10, M-12) (E-9, E-11, G-11, H-10)
IRL	IN-RANGE LIGHT (OPTION) (L-13)
PR	PROBE RECEPTACLE (USDA OPTION) (F-19, M-20, N-20, P-20)
RM	REMOTE MONITORING RECEPTACLE (OPTION) (L-8, L-9, L-13)
RRS	RETURN RECORDER SENSOR (L-19)
RTS	RETURN TEMPERATURE SENSOR (C-18)
SMV	STEPPER MOTOR SUCTION MODULATION VALVE (T-14)
SPT	SUCTION PRESSURE TRANSDUCER (OPTION) (J-20)
SRS	SUPPLY RECORDER SENSOR (OPTION) (B-18)
ST	START - STOP SWITCH (K-5)
STS	SUPPLY TEMPERATURE SENSOR (B-18)
TC	CONTROLLER RELAY - COOLING (K-8)
TCC	TRANSFRESH COMMUNICATIONS CONNECTOR (OPTION) (D-7)
TE	CONTROLLER RELAY (HIGH SPEED EVAPORATOR FANS) (F-10) (K-11)
TF	DEFROST RELAY (K-14) (K-8)
TFC	TRANSFRESH CONTROLLER (OPTION) (G-7)
TH	CONTROLLER RELAY (HEATING) (K-13)
TI	INRANGE RELAY (K-13)
TL	CONTROLLER RELAY (COOL LIGHT) (K-11)
TN	CONTROLLER RELAY (CONDENSER FAN) (K-9)
TP	TEST POINT (E-10, F-9, J-8, J-9, J-13, M-14) (F-10, J-8, J-10, J-11, J-12, M-13)
TR	TRANSFORMER (M-3)
TRANS	AUTO TRANSFORMER 230/460 (OPTION) (D-2)
TRC	TRANSFRESH REAR CONNECTOR (OPTION) (E-7)
TV	CONTROLLER RELAY (LOW SPEED EVAPORATOR FANS (F-12) (K-11)
VPS	VENT POSITION SENSOR (UPPER) (OPTION) (N-14)
WCR	WETTING CURRENT RESISTER (OPTION) (J-10)
WP	WATER PRESSURE SWITCH (OPTION) (E-9)

Figure 7-1 LEGEND

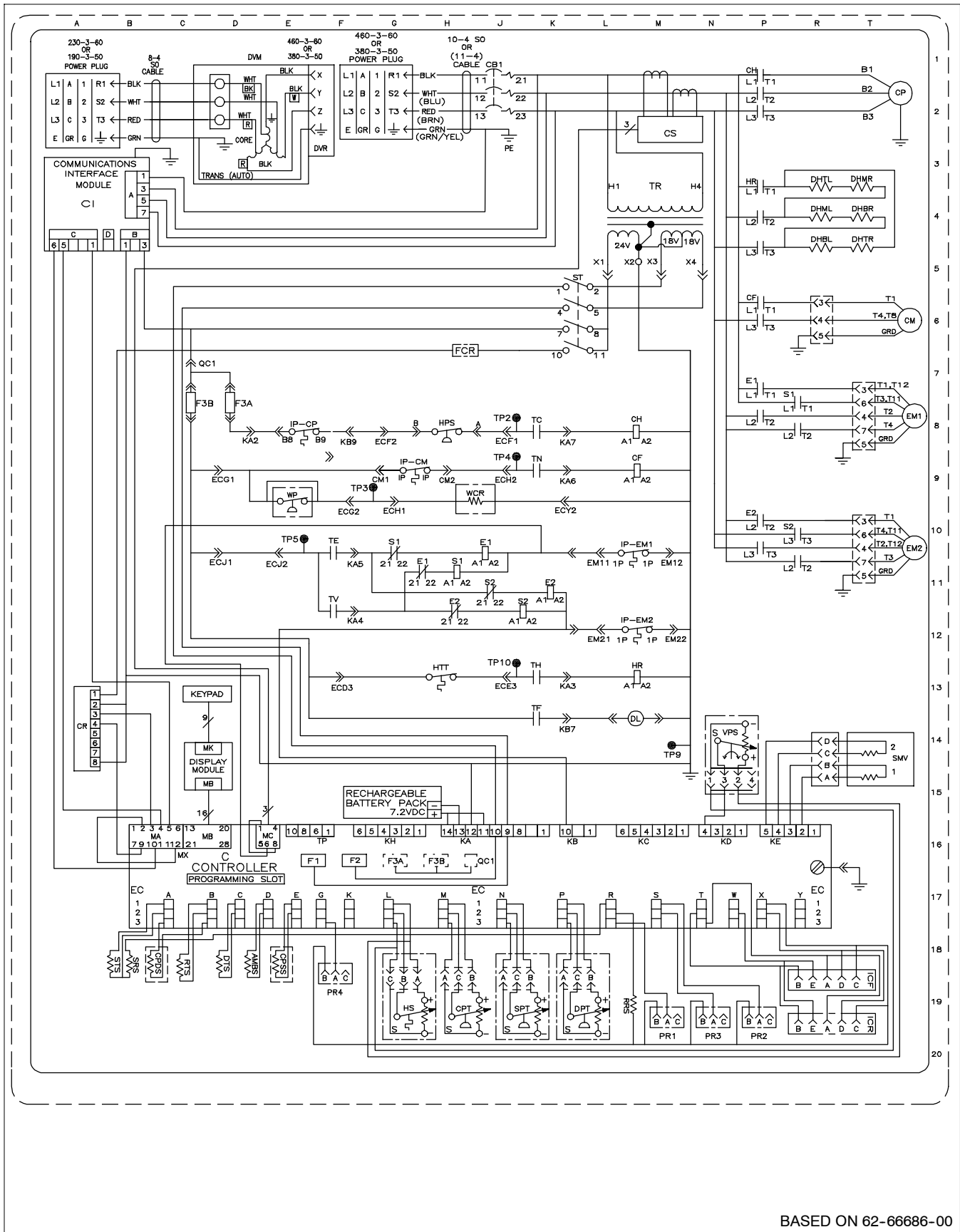

Figure 7-2 SCHEMATIC DIAGRAM - Units with Single Evaporator Fan Capability & VPS

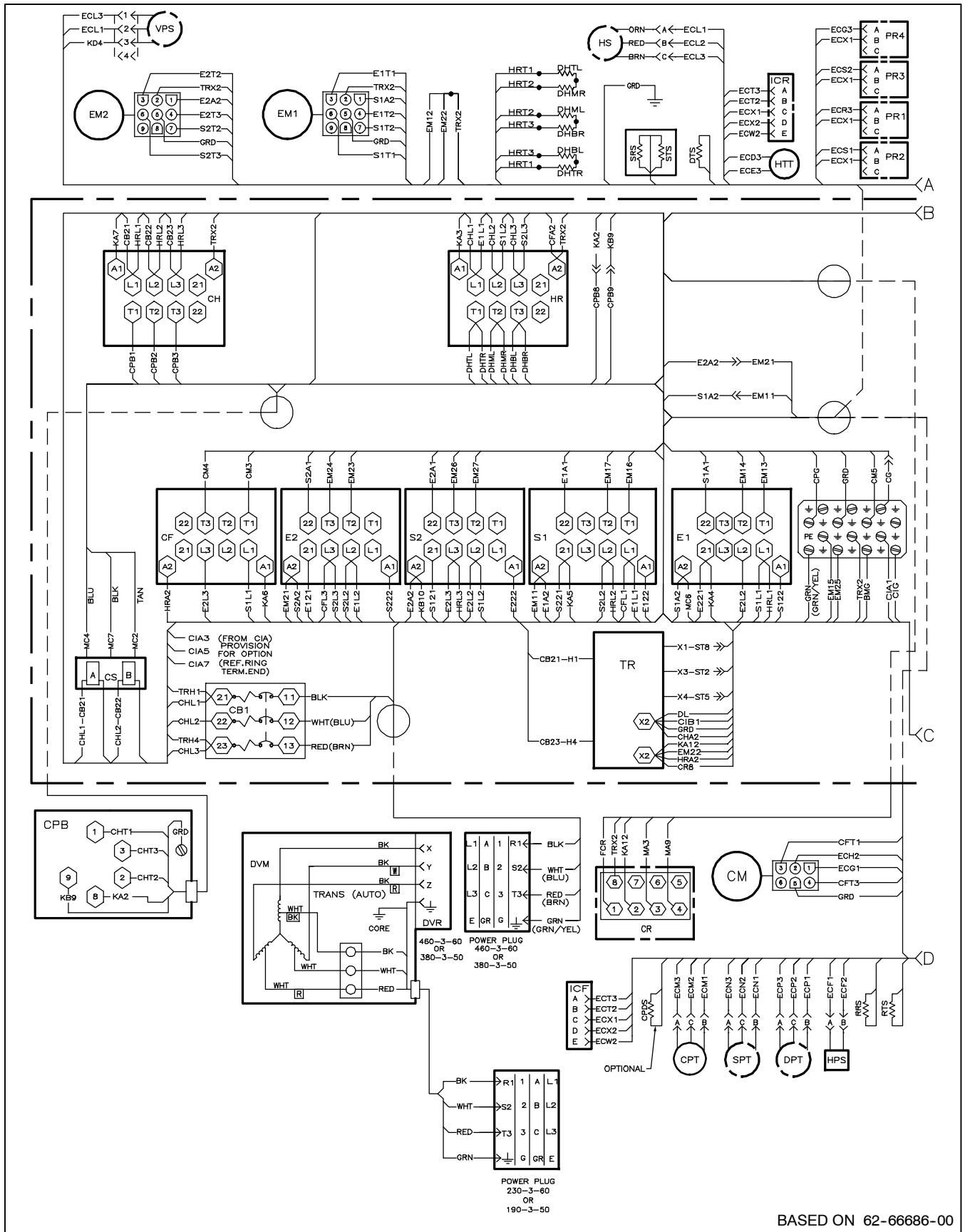
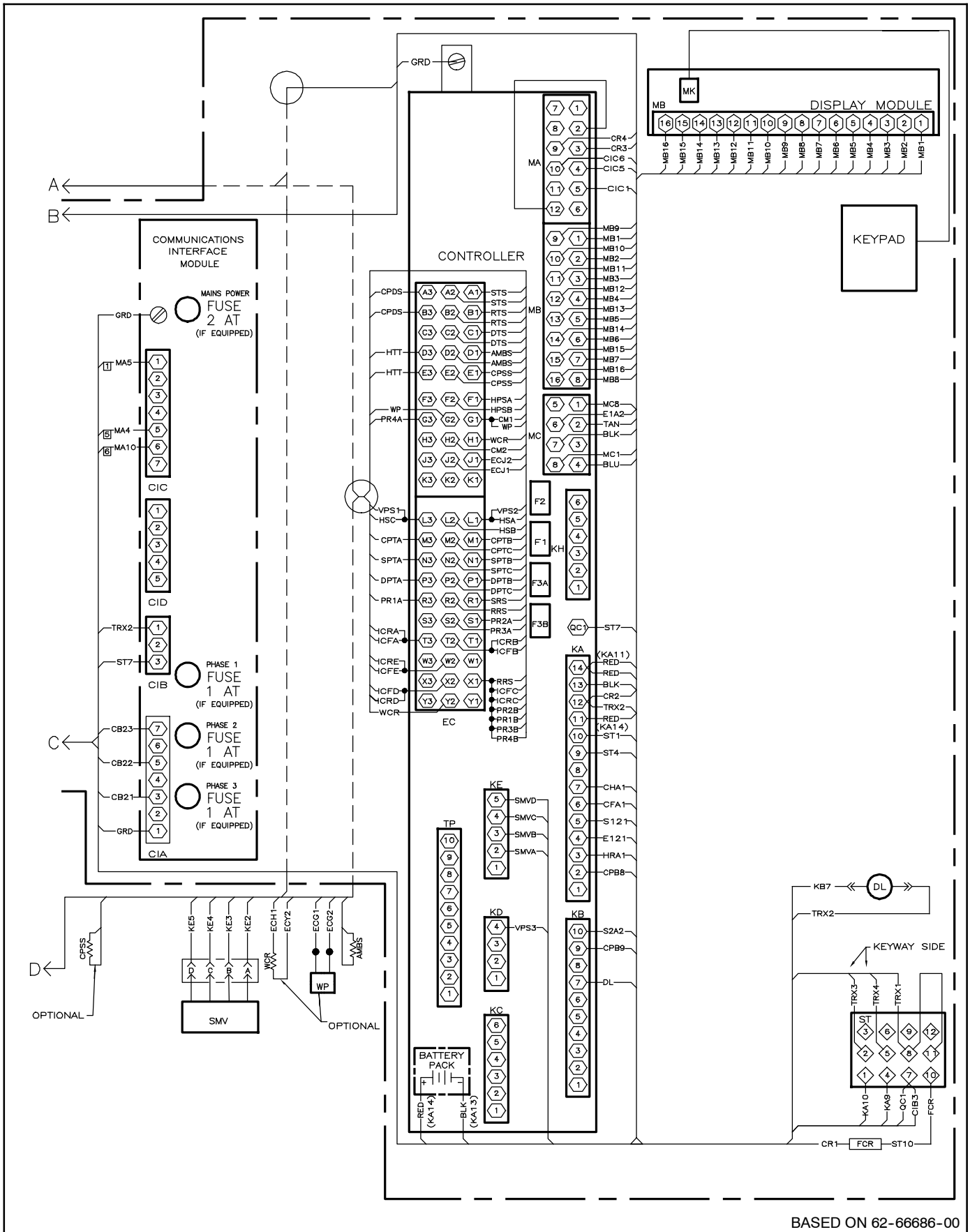
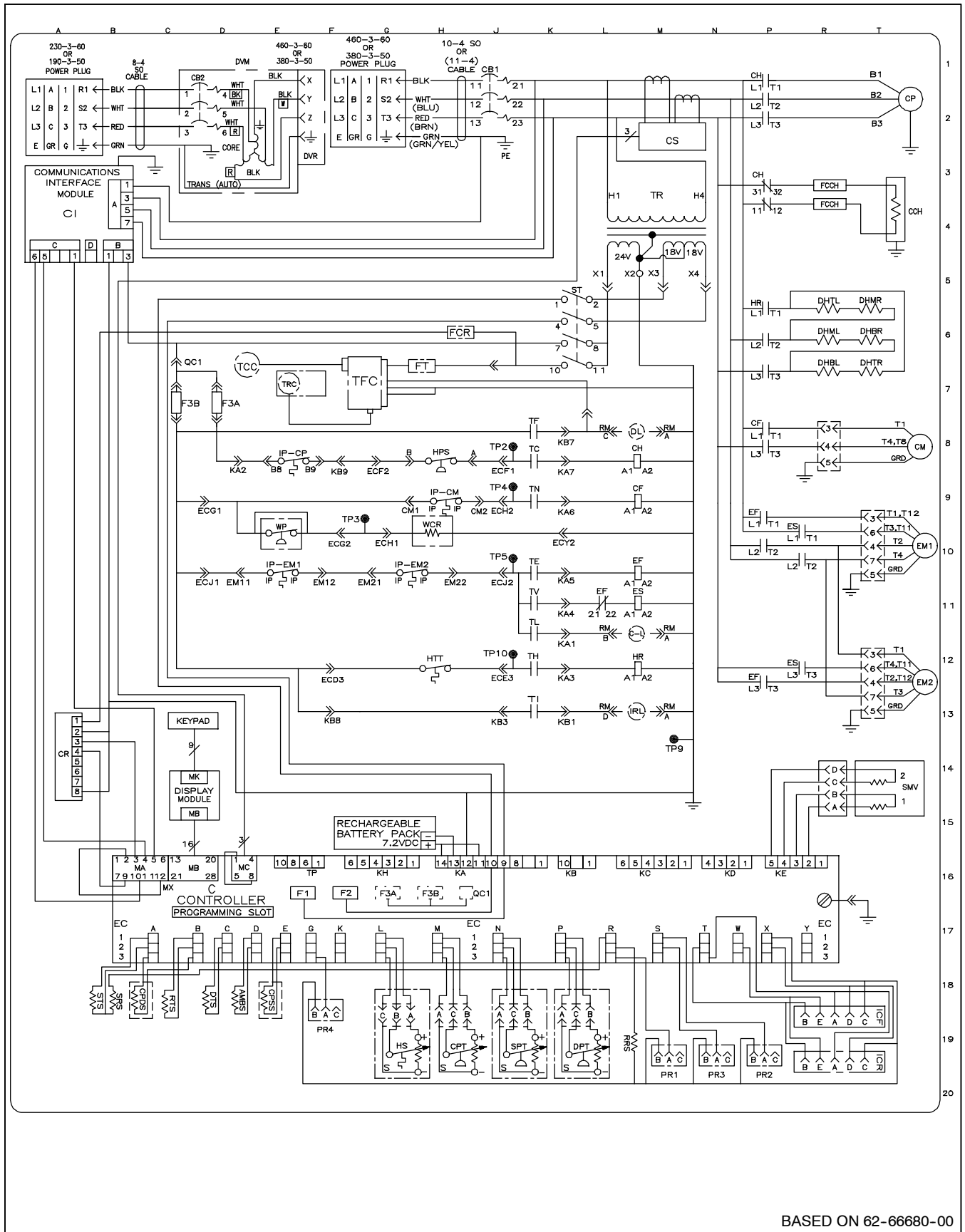

Figure 7-3 UNIT WIRING DIAGRAM - Units with Single Evaporator Fan Capability & VPS (Sheet 1 of 2)



BASED ON 62-66686-00

Figure 7-4 UNIT WIRING DIAGRAM - Units with Single Evaporator Fan Capability & VPS.
(Sheet 2 of 2)



BASED ON 62-66680-00

Figure 7-5 SCHEMATIC DIAGRAM - Units with Normal Evaporator Fan Capability, TransFresh & Crankcase Heater

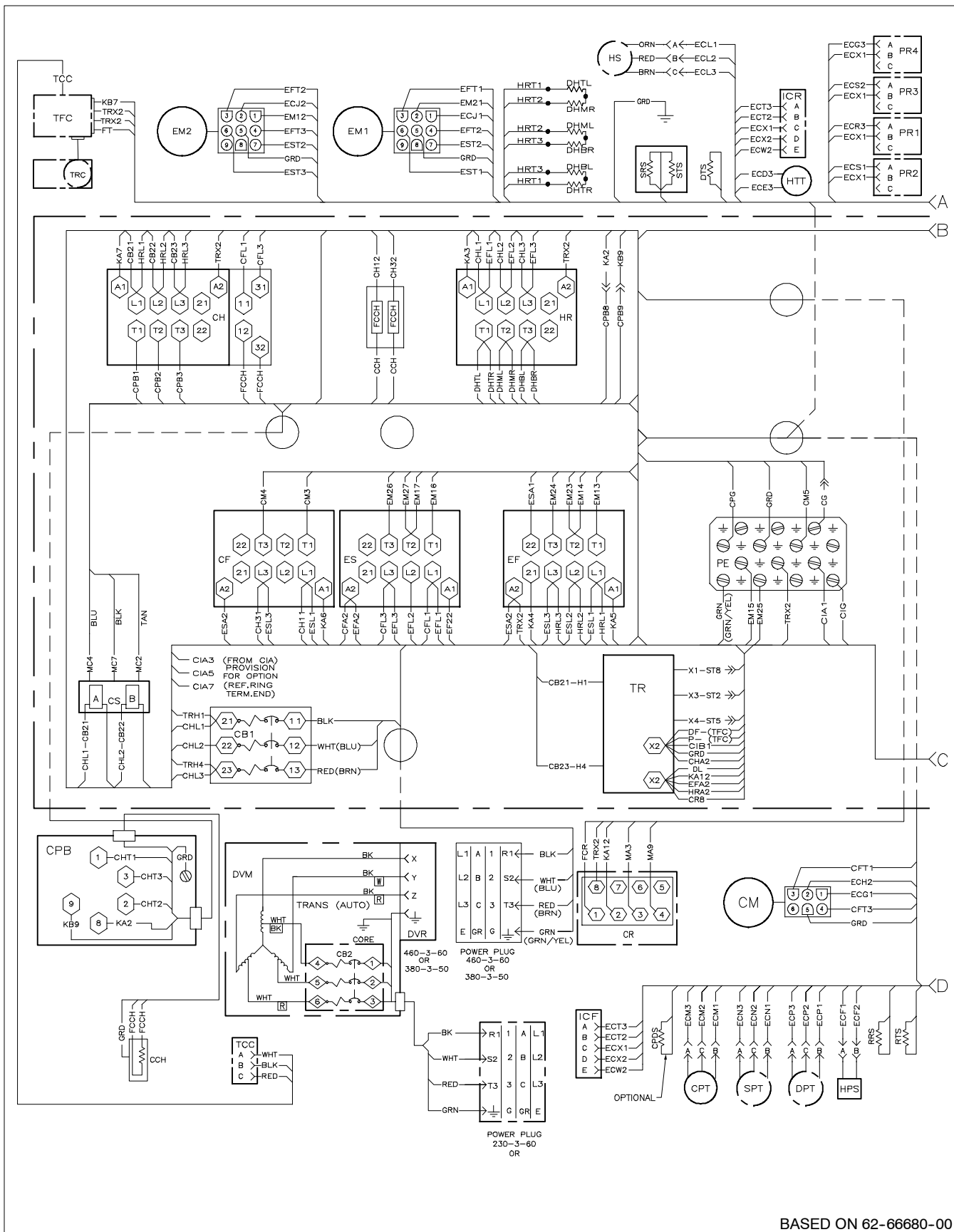

BASED ON 62-66680-00

Figure 7-6 UNIT WIRING DIAGRAM - Units with Normal Evaporator Fan Capability, TransFresh & Crankcase Heater (Sheet 1 of 2)

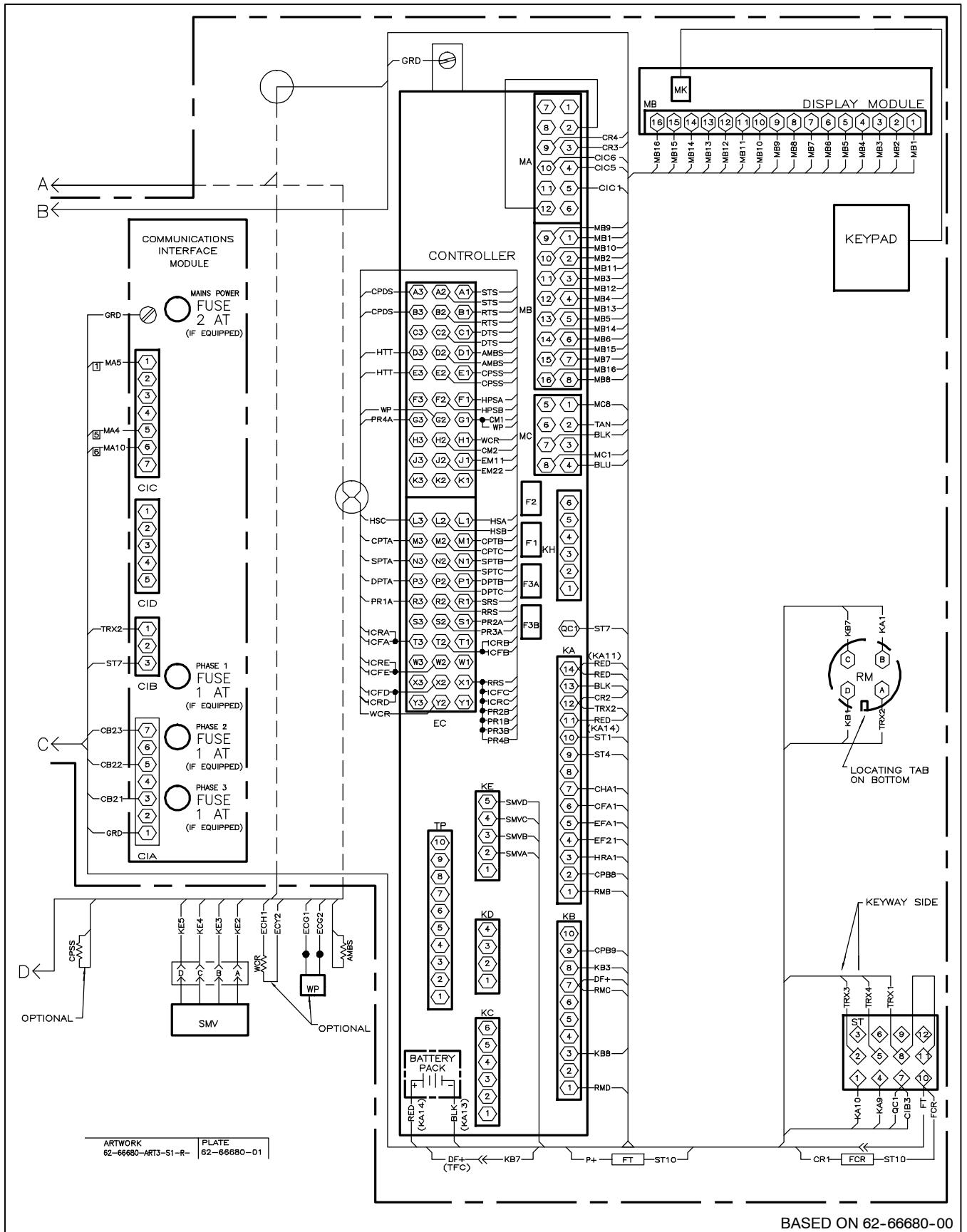

Figure 7-7 UNIT WIRING DIAGRAM - Units with Normal Evaporator Fan Capability, TransFresh & Crankcase Heater (Sheet 2 of 2)

INDEX

A

Air Cooled Condenser Section, 2-4
Alarm, 3-6, 3-9, 3-12, 3-18, 3-19, 3-20, 3-21,
3-28
Aluminum oxide, 6-16
Ambient sensor (AMBS), 3-24
Arctic Mode, 3-4
ARCTIC OPTION, 2-12

B

Battery Replacement, 6-21
Bulb Mode, 3-5

C

Capacitors, 6-16
Checking Superheat, 6-13
Checking the Capacitor, 6-16
Checking the Controller, 6-18
Checking the Stepper Valve, 6-18
Chips and Holes, 6-26
Communications Interface Module, 3-11, 6-29
Composite Control Box, 6-26
Compressor, 6-5
Compressor Crankcase Heater, 2-12
Compressor discharge sensor (CPDS), 3-24
Compressor Section, 2-3
Condenser Coil, 6-10
Condenser Pressure Control, 3-4
Condenser pressure transducer (CPT), 3-24
Configurable Functions, 3-15
Configuration Software, 3-3, 3-8
Configuration Variables, 3-13
Controller, 3-3, 6-18, 6-19
Controller Configuration Variables, 3-13
Controller Function Codes, 3-14, 3-17
Controller Pre-Trip Test Codes, 3-23
Controller Programming, 6-20

Controller Software, 3-3
Controller Troubleshooting, 6-20
Cracks, 6-26
Crankcase Heater, 4-5

D

Data Reader, 3-11
DataBANK™ Card , 3-11
DataCORDER, 3-7, 3-9, 4-3
DataCORDER Alarms, 3-12
DataCORDER Communications, 3-11
DataCORDER Software, 3-1, 3-8
DataCORDER Standard Configurations, 3-9
DataReader, 3-11
Defrost Interval, 3-4
Defrost Mode, 4-8
Defrost temperature sensor (DTS), 3-25
Discharge pressure transducer (DPT), 3-24
Display Module, 3-2
Display Only Functions, 3-14
DPRV CHECK PROCEDURE, 6-19
DPRV Replacement Value Chart, 6-19

E

Electrical Schematic, 7-1
Emergency Bypass, 4-9
Emergency Defrost, 4-10
Emergency Repair Procedures, 6-18
Evacuation, 6-3
Evaporator, 6-14
Evaporator Coil Replacement, 6-14
Evaporator Fan, 1-2, 3-4, 6-15

INDEX - Continued

Evaporator Heater Replacement, 6-14
Evaporator Section, 2-2
EVAPORATOR SECTION CLEANING, 6-16
Expansion Valve, 6-12
Expansion Valve Replacement, 6-13

F

Failure Action, 3-4
Filter-Drier, 6-12
Fresh Air Makeup, 2-1, 4-2
Frozen Mode, 4-8
Frozen Mode - Conventional, 3-6
Frozen Mode - Economy, 3-6
Fumigation, 6-16
Function Code, 3-14, 3-15, 3-26

G

General Description, 2-1
Generator Protection, 3-4
Generic Mode, 3-8

H

Heat Lockout, 3-4
Heater, 6-14
Heating Mode, 4-7
Hermetic Thermostatic Expansion Valve Brazing Procedure, 6-13
High Pressure Switch, 6-10
High pressure switch (HPS), 3-24

I

Inspection, 4-1, 4-3
Introduction, 1-1

K

Key Pad, 3-2
Keypad Function, 3-2

L

Leak Checking, 6-3
Logging Interval, 3-9
Lower Air, 1-2

M

Manifold Gauge Set, 6-1
Micro-Link 3 Controller, 3-3
Microprocessor System, 3-1
Modes Of Operation, 3-4
Motor Current, 6-33

O

Oil Level , 6-9
Operational Software, 3-3, 3-8

P

Painted Surfaces, 6-26
Perishable Mode, 4-7
Perishable Mode - Conventional, 3-5
Perishable Mode - Dehumidification, 3-5
Perishable Mode - Economy, 3-5
Power, 4-1
Pre-Trip, 3-7, 3-11, 3-22, 3-27, 4-3
Probe Check, 4-5
Pumping Down, 6-3

INDEX - Continued

R

Refrigerant Charge, 6-4
Refrigeration Circuit, 2-10
Refrigeration Circuit Schematic, 2-11
Refrigeration System Data, 2-7
Refrigeration Unit - Front Section, 2-1
Removing the Capacitor , 6-16
Replacing the Recorder , 6-24
Return Recorder Sensor (RRS), 3-17
Return Sensor Positioning, 6-23
Return temperature sensor (RTS), 3-24

S

Safety and Protective Devices, 2-9
Sensor and Cable Splice, 6-22
Sensor Configuration, 3-8
Sensor DTS, 6-23
Sensor Replacement, 6-22
Sensor STS/SRS, 6-23
Sensors RTS/RRS, 6-23
Sequence Of operation, 4-7
Service Valves, 6-1
Standard Configuration Report, 3-10
Starting, 4-3
Stopping, 4-3
Suction Modulating Valve, 6-17
Suction Modulation Valve, 3-14
Supply Recorder Sensor (SRS), 3-17
Supply Sensor Positioning, 6-23
Surface corrosion, 6-16
Switch functions, 3-2

T

Temperature Control, 3-4, 3-6
Temperature Recorder, 4-3, 6-24
Temperature Sensor, 6-21
Thermistor Format, 3-9
Thermostatic Expansion Valve Bulb, 6-13
Torque Values, 6-30, 6-31

U

Upper Air, 1-2
USDA, 3-11
USDA Cold Treatment Procedure, 3-12
USDA Recording, 3-11
USDA Message Trip Comment, 3-11

V

Valve functions, 6-12
Vent Position Sensor (VPS), 3-17, 6-23

W

Water Cooled Condenser, 6-11
Water pressure switch (WP), 3-24
Water-Cooled Condenser Cleaning, 6-12
Water-Cooled Condenser Section, 2-5
Wear Limits, 6-30
Wiring Diagrams, 7-1



A member of the United Technologies Corporation family. Stock symbol UTX
©2010 Carrier Corporation • Printed in U. S. A. 1210



Carrier

A United Technologies Company

Carrier Transicold Division,
Carrier Corporation
Container Products Group
P.O. Box 4805
Syracuse, N.Y. 13221 U.S.A.

www.carrier.transicold.com