

TDH 02

MICROPROCESSOR-BASED DIGITAL ELECTRONIC CONTROLLER



OPERATING INSTRUCTIONS Vr. 01 (I - GB) - cod.: ISTR 00540

PREVIOUS STATEMENT: In this manual are contained all the necessary information for a correct installation and the instructions for the use and the maintenance of the product; we recommend, therefore, to read carefully the following instructions. The maximum care has been used in the realisation of this document, anyway TECNOLOGIC S.p.A. does not assume any responsibility deriving from the use of itself. The same consideration has to be done for each person or Company involved in the creation of this manual. The herewith issue is an exclusive property of TECNOLOGIC S.p.A. which forbids any reproduction and divulgation, although partial, if not expressly authorised. TECNOLOGIC S.p.A. reserves the right to execute aesthetically and functional modifications, at any moment and without any notice.

INDEX

- 1 GENERAL DESCRIPTION**
- 1.1 FRONT PANEL
- 1.2 INSTRUMENT CODE
- 2 TECHNICAL DATA**
- 3 INSTALLATION**
- 4 OPERATING MODE**
- 4.1 ON/OFF CONTROL
- 4.2 NEUTRAL ZONE CONTROL
- 4.3 PID CONTROL AND AUTOTUNING FUNCTION
- 4.4 DYNAMIC SET POINT FUNCTION
- 5 PROGRAMMING**
- 5.1 PROGRAMMING OF SET-POINT
- 5.2 PROGRAMMING OF PARAMETERS
- 5.3 PROGRAMMING OF INPUT LIMITS
- 6 DESCRIPTION OF PARAMETERS**
- 6.1 PARAMETERS TABLE
- 7 TROUBLES, MAINTENANCE, GUARANTEE**

1 - GENERAL DESCRIPTION

TDH 02 is a digital microprocessor based controller with 1 or 2 set point, ON/OFF, PID or NEUTRAL ZONE mode and with AUTOTUNING

function for PID mode. The process value is visualised on 3 red displays and the outputs state is indicated by 2 leds. The instrument has 1 or 2 outputs relay or for solid state relay (SSR) driving and 1 input for PTC (KTY 81), or RTD (Pt 100 or Ni100), or Thermocouple (J-K-S) temperature probes or for any kind of probe having normalised output in current (4..20 mA, 0..20 mA) or voltage (0..10 V).

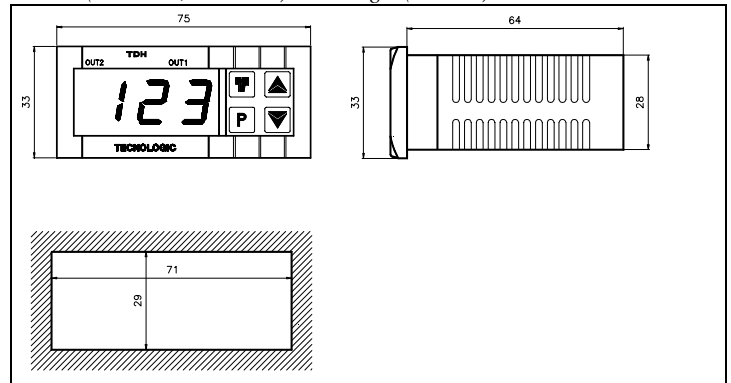

1.1 - FRONT PANEL

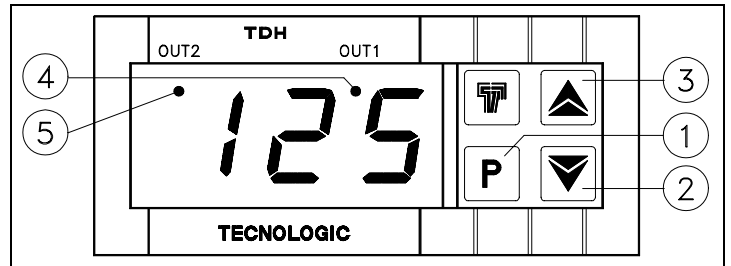

1 - Key P : Used for the set point setting and to program the functioning parameters

2 - Key DOWN : Used to decrease the values or to select parameters

3 - Key UP : Used to increase the values or to select parameters

4 - Led OUT1 : Signalize when the output OUT1 is on (on) or off (off) and signalize the set point 1 or the parameters programming mode (flashing)

5 - Led OUT2 : Signalize when the output OUT2 is on (on) or off (off) and signalize the set point 2 programming mode (flashing)

1.2 - INSTRUMENT CODE

TDH 02 a b c d e e

a = SUPPLY

F : 12 VAC/VDC

G : 24 VAC/VDC

b = INPUT

C : Termocouples (J, K, S)

D : Termoresistances (Pt100, Ni100 IEC)

E : Termistors PTC (KTY 81)

F : Normalized signals 4..20 mA

A : Normalized signals 0..20 mA

V : Normalized signals 0..10 V

c = OUTPUT OUT1

R : Relay

O : Voltage output 12 VDC for SSR

d = OUTPUT OUT2

R : Relay

O : Voltage output 12 VDC for SSR

- : Output not present

ee = SPECIAL CODES

2 - TECHNICAL DATA

ELECTRICAL DATA

Supply: 12, 24 VAC/VDC +/- 10%

Frequency AC: 50/60 Hz

Power consumption: 3 VA approx.

Input/s: 1 input. For temperature probes tc J, K, S or RTD Pt 100 IEC, Ni 100 or PTC (KTY 81-121 990 Ω at 25 °C) or for normalized signals 4..20 mA, 0..20 mA o 0..10 V

Output/s: Up to 2 outputs. Relay (8A-AC1, 3A-AC3 250 VAC) ; or voltage for SSR drive (12 VDC/25 mA)

Auxiliary supply output: 12 VDC / 25 mA Max (only for norm. sign..)

Electrical life for relay output: 100000 operat.

Protection class against electric shock: Class II for Front panel

Insulation: Reinforced insulation between the low voltage section (relay outputs) and the front panel; Reinforced insulation between the low voltage section (relay outputs) and the extra low voltage section (supply and input); No insulation between supply, input and output for SSR driving

MECHANICAL DATA

Housing: Self-extinguishing plastic, UL 94 V0

Dimensions: 33 x 75 mm, depth 64 mm

Weight: 110 g approx.

Mounting: Flush in panel in 29 x 71 mm hole

Connections: 2,5 mm² screw terminal block

Degree of protection of front panel : IP 65 mounted in panel with gasket

Pollution situation: Normal

Operating temperature: 0 ... 55 °C

Operating humidity: 30 ... 95 RH% without condensation

Storage temperature: -10 ... +60 °C

FUNCTIONAL DATA

Control: ON/OFF, NEUTRAL ZONE, PID

Measurement range: according to the used probe (see table range)

Display resolution: according to the probe used 1/0,1/5/0,5

Overall accuracy: +/- 0,5 %fs

Sampling rate: 1 sample per second

Action: 1C type according to EN 60730-1

Compliance: ECC directive EMC 89/336 (EN 50081-1, EN 50082-1), ECC directive LV 73/23 and 93/68 (EN 60730-1)

MEASUREMENT RANGE TABLE

PROBE	3 DIGIT	3 DIGIT with D.P.
PTC	-50 ... +150 °C	-9.9 ... +99.9 °C
	-58 ... +302 °F	-9.9 ... +99.9 °F
Pt 100 (Pt)	-99 ... +600 °C	-9.9 ... +99.9 °C
	-99 ... +999 °F	-9.9 ... +99.9 °F
Ni 100 (ni)	-50 ... +150 °C	-9.9 ... +99.9 °C
	-58 ... +302 °F	-9.9 ... +99.9 °F
tc J (FE)	0 ... +800 °C	---
	+32 ... 999 °F	---
tc K (Cr)	0 ... +999 °C	---
	+32 ... +999 °F	---
tc S (rh)	0 ... +999 °C	---
	+32 ... +999 °F	---
4..20 mA, 0..20 mA, 0..10 V (gener.)	- 99 ... 999	-9.9 ... 99.9

3 - INSTALLATION

MECHANICAL MOUNTING: The instrument, in case 33 x 75 mm, is designed for panel mounting. Make an hole 29 x 71 mm and insert the instrument, fixing it with the provided special bracket . We recommend to mount the gasket to obtain an IP 65 front protection. Avoid to place the instrument in areas with humidity or dirt. Connect the instrument as far as possible from source of electromagnetic disturbances so as motors, power relays, relays, electrovalves, etc.

ELECTRICAL CONNECTIONS: Carry out the electrical wiring connecting only one wire for each terminal , according to the following diagram, check that the power supply is the same as indicated on the instrument and the loads current is not upper than the maximum current admitted. The instrument, being a built in equipment with permanent connection into a cabinet, is not furnished with internal device protecting from overcurrent : it's recommended , therefore, to properly protect all the electric circuits connected to the instrument, with devices (ex. fuses) proportionate to the circulating currents. It's strongly recommended to use cables with proper insulation, according to the working voltages and temperatures. Furthermore, the input cables has to be kept separate from line voltage wiring. If the input cables is screened, it has to be connected on the ground with only one side. It is advisable to check that the parameters are those desired before connecting the outputs to the actuators so as to avoid malfunctioning . Whenever a failure of the instrument could cause dangerous or damaging situations, it should be kept in mind that the plant has to be provided with additional devices to

ensure the safety. It's recommended to supply the instrument using the Tecnologic TCTR transformer or equivalent type, and to use one transformer for each instrument.

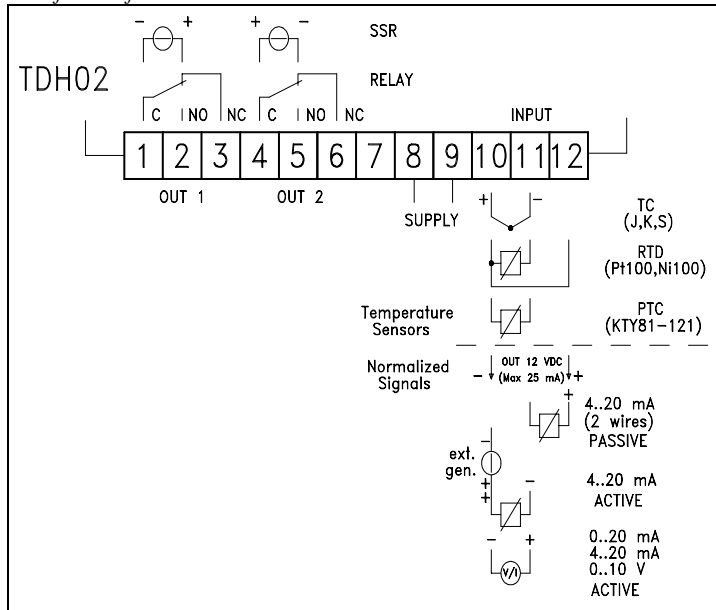

4 - OPERATING MODE

4.1 - ON/OFF CONTROL

The control mode of the instrument by ON/OFF mode occurs on the outputs according to the Sets point fixed, to the differential switching points (par. "d1", "d2") and to operating modes (par. "HC1", "HC2") programmed. For a correct functioning it is necessary to set a negative differential switching point for reverse controls (ex.Heating processes) and a positive differential switching point for direct controls (ex.Cooling processes). Furthermore the two Sets can be programmed independently or dependently through the parameter Sets Connection ("OCO"), and in the case of set dependently the real regulation Set of output 2 will be [Set1+Set2]. If output 2 is used as an alarm output, par. "OCO" determines if the alarm is absolute or relative (in=absolute, di=relative) and par. "HC2" determines if the alarm is low or high (H=low, C=high). The operating mode can be also modified by means of outputs delay parameter (par. "od") or Dynamic Set Point function, see the next chapters for these functions.

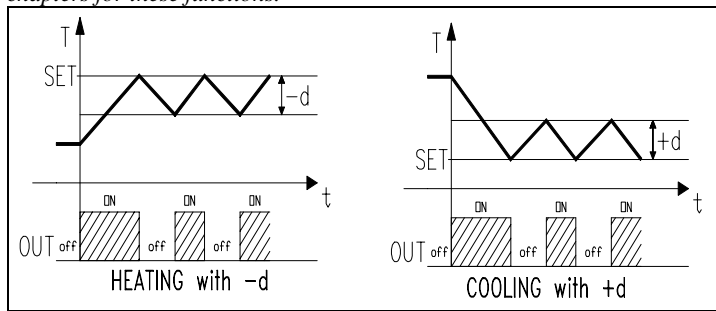

4.2 - NEUTRAL ZONE CONTROL

The Neutral Zone control mode concerns both outputs and is generally necessary for controlling a plant that possesses a Positive regulation element (ex. Heating, Humidification etc.) and a Negative regulation element (ex. Cooling, Dehumidification etc.) . The functioning is determined by the Set1 (Set2 is automatically disconnected) and Neutral Zone (par. "db"). Subsequently the regulator operates as follows: switches off the outputs when the process value is the same as Set, switch on the output OUT1 when the process value is under as [Set1-db], and switch on the output OUT2 when the process value is upper as [Set1+db]. Thus the Positive regulation element will be connected to output OUT1, while the Negative regulation element is at output OUT2.

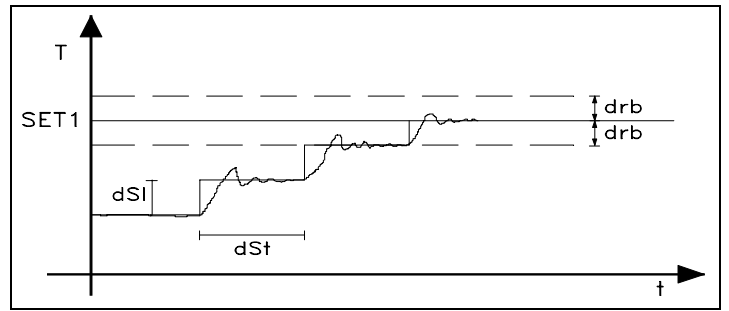
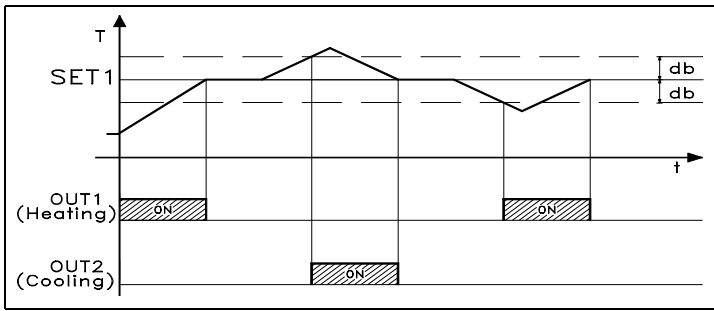

4.3 - PID CONTROL AND AUTOTUNING FUNCTION

PID control mode can only be carried out through output OUT 1 while output OUT 2 can only operates by means of ON/OFF control mode with Set 2 independent or depended in respect with Set 1 and can therefore be used as an alarm (see ON/OFF regulator). The PID algorithm of the instrument is provided to program the following parameters:

For PROPORTIONAL term :

"Pb" - Proportional Band,

"rst" - Manual reset

"Ct" - Cycle time.

For INTEGRAL term:

"It" - Integral time

For DERIVATIVE term:

"dt" - Derivative time

The instrument is set on parameters relative to PID control of standard value. If ever these should result to be unsuitable it would be advisable to program the AUTOTUNING function. The Autotuning function permits the automatic tuning of the PID instrument parameters.

To active the AUTOTUNING function proceed as follows :

- Set the desired "Set point".
- Set the desired parameters and especially "HC1".
- Set the parameter "Ft": Pi
- Connect the instrument with the plant
- Set the parameter "tun" : y
- Wait for the outing from the programming

Now, the Autotuning function is activated and it's shown by the flashing of the process value on the display. The regulator automatically tunes all the right parameters for a correct PID control mode. Before to switch off the instrument always wait for the end of the Autotuning process, indicated by the return of the display on the normal functioning. The Autotuning procedure has been limited at a maximum time of 4 hours, after this time, if the Autotuning is not completed the instrument automatically get out from the procedure, showing constantly on the display the "EEE" indication. To stop the Autotuning cycle or re-establish the normal functioning after an error, switch off and on the instrument. The calculated values will be automatically memorised by the instrument at the end of the Autotuning cycle, in the PID control parameters.

4.4 - DYNAMIC SET POINT FUNCTION

This function is only obtainable through output OUT 1 and is useful to avoid starting over-emption of the process value caused by the inertness of the system or when is wished a gradual reaching of Set value. Infact by means of this function an automatic increase in the time of the regulation Set from the power on-process value to the programmed Set is obtained. The parameters to be programmed for this function are:

"drb" : Symmetrical semi-band over-lapping the Set outside from which the function is activated.

"dSI" : Increment value of dynamic Set between two successive increments of the dynamic Set value.

"dSt" : Time lapse between two successive increments of the dynamic Set value.

The Dynamic Set Point function is automatically disconnected by setting dSi = 0.

5 - PROGRAMMING

5.1 - PROGRAMMING OF SET-POINTS

Press key P then release it, led OUT1 will flash and the SET1 value will be shown on display. To modify press key UP so as to increase value or DOWN so as to decrease it. These keys count one digit at a time but if the keys are pressed for over one second the value increases or decreases fast and after two seconds the speed increases even more, so as to reach the desired value immediately. Pressing key P again and releasing it, led OUT2 will flash and SET2 which was previously set, will be displayed, it can be modified by pressing keys UP or DOWN as already mentioned. The outgoing from the Set programming mode occurs automatically by not pressing any key for about 5 seconds, thus the process value will again be displayed.

5.2 - PROGRAMMING OF PARAMETERS

To accede to the operating parameters it is necessary to press key P holding it down for about 5 seconds, afterwhitch the led OUT1 will flash and the code of the first parameter will be visualized on the display. At this point key P can be released and by pressing UP or DOWN the desired parameter can be selected. Once the parameter on which we intended to operate has been selected to modify it press P, while holding it down, the set of the parameter will show up. To modify this value keep P pressed while acting on UP or on DOWN so as to increase or decrease the value. Once the desired value has been set release P and the selected parameter code can be read on the display. By pressing UP or DOWN it is therefore possible to choose another one and modify it as previously mentioned. To outgoing from the programming mode no key is to be pressed for about 20 seconds, the instrument will automatically return to normal functioning mode, visualizing the process value.

The instrument must not be switched off during the programming mode otherwise the data inserted in the last session will not be memorized.

P.A.: When programming operating parameters some parameters will not displayed, this happens because the instrument is predisposed to automatically not visualize the unnecessary parameters.

5.3 - PROGRAMMING OF INPUT LIMITS

If the instrument is provided with input for normalized signals 4..20 mA, 0..20 mA or 0..10 V it is necessary to set input limits to have the correct measure indication. For example: if the probe to connect has a range of 0..100 bar, it will be necessary to program 0 on "Lci" parameter (start scale) and 100 on "Hci" parameter (end scale). At same time, we have to modify the same parameters to have the decimal point. Example: instrument connected with relative humidity probe with 20..99 %RH as range, to have the decimal point it will occur to program "dP" in "on" mode, "Lci" at 20.0 and "Hci" at 99.9.

6 - DESCRIPTION OF PARAMETERS

Here following are described all the instrument parameters; pls. note that some of them could do not appear or because are according to the kind of used instrument or because are automatically not qualified, as they're not necessary.

d1 - DIFFERENTIAL SWITCHING POINT1: Value between starting and stopping of output OUT1.

d2 - DIFFERENTIAL SWITCHING POINT2: Value between starting and stopping of output OUT2.

db - NEUTRAL ZONE : Value which represents the semi-band of the Neutral Zone, in the homonymous functioning mode, overlapping Set1.

LS1 - MINIMUM SET1: Minimum possible Set point 1 value or lower limit of Set point 1.

LS2 - MINIMUM SET2: Minimum possible Set point 2 value or lower limit of Set point 2.

HS1 - MAXIMUM SET1: Maximum possible Set point1 value or higher limit of Set point1.

HS2 - MAXIMUM SET2: Maximum possible Set point2 value or higher limit of Set point2.

Pb - PROPORTIONAL BAND : Amplitude of the band around Set 1 in which proportional control takes place.

It - INTEGRAL TIME : Integral time to be set in algorithm of PID control mode.

dt - DERIVATIVE TIME: Derivative time to set in algorithm of PID control mode.

rSt - MANUAL RESET : Offset value for proportional band.

od - OUTPUTS DELAY: Delay from when the control need a variation to the condition of the outputs to when this actually happens (expr. in sec.). Non operating on output Out 1 in PID control mode.

Ct - CYCLE TIME: Cycle time of OUT 1 when proportional control takes place in PID control mode.

drb - RESTART BAND DYNAMIC SET: Semiband found in the symmetrical zone in respect with Set outside of which intervenes the functioning of the Dynamic Set Point.

dSI - DYNAMIC SET INCREMENT: Increment value of dynamic Set Point function between two successive instant determines by the par. dSt.

dSt - DYNAMIC SET INCREMENT INTERVAL: Interval between one Dynamic Set Point increment and the next (expr. in sec.).

Lci - LOWER NORMALIZED SIGNALS INPUT LIMIT: Value that the instrument must to indicate in correspondance of minimum value (4 mA, 0 mA, 0 V).

Hci - HIGHER NORMALIZED SIGNALS INPUT LIMIT: Value that the instrument must to indicate in correspondance of maximum value (20 mA, 10 V).

CAL - CALIBRATION: Positive or negative offset which is calculated on probe reading before visualizing and to which the control functioning is also connected. This parameter can be utilized when a recalibration of the instrument is desired.

Ft - CONTROL MODE: Allows the selection of one of possible control modes that the instrument offers: ON/OFF (on), PID (Pi) or Neutral Zone (nr).

PSE - INPUT PROBE: Allows selecting, if the instrument type is for thermocouples or for thermoresistances, various types of probe: J (FE), K (Cr), S (rh) for thermocouples and Pt100 (Pt), Ni100 (ni) for thermoresistances. On changing this parameter it is to be remember that the exit programming phase is to be carried out first afterwhitch the instrument is to be switched off and then on again.

OCO - SETS CONNECTION: Determines if the two Sets are to be independent or if Set2 must be considered relative to Set1 (in=independent, di=dependent).

HC1 - OUTPUT 1 OPERATING MODE: Determines if the output OUT1 is to control a process which increment is intended as positive or reverse (ex. Heating, Humidification etc.) or a process which increment is intended as negative or direct (ex. Cooling, Dehumidification etc.) (H=reverse , C=direct).

HC2 - OUTPUT 2 OPERATING MODE: Determines if the output OUT2 is to control a process which increment is intended as positive or reverse (ex. Heating, Humidification etc.) or a process which increment is intended as negative or direct (ex. Cooling, Dehumidification etc.) (H=reverse , C=direct).

dP - DECIMAL POINT : Allows the insertion of the decimal point on the display and therefore to determine resolution of the reading value (1 or 0,1) but not modified the Set, the Set limits (par. "LS", "HS") and the input limits (par. "Lci", "Hci"). Example, if the Set was 20 the new Set will be 2.0 (on= with decimal point, oF=without decimal point).(available only for models provided for PTC, RTD and normalized signals input).

rou - UNIT OF MEASUREMENT: Determines the visualization of the temperature in Centigrade or Fahrenheit degree. It is to be remember that the change of this parameter modifies the visualization but not the Set and

the Set limit ("LS" and "HS") programmed (eg. if the Set was 50°C and the unit changes, the Set will rest 50°F).

tun - AUTOTUNING: Determines the selection of Autotuning function for the automatic setting of PID parameters (n=no autotuning, y=start autotuning).

hdd - HALF DIGIT DISPLAY: This parameter allows the approximation of the last digit at right side. Infact when this parameter is in on mode, on this digit will be show 0 when the real measuring value is between 0 and 4, and will be show 5 when the real measuring value is between 5 and 9. For example if the real measure is 78 display will show 75, or if the real measure is 70.3 the display will show 70.0 (n=without approximation, y=with approximation).

tAb - FIXED PARAMETER

6.1 - PARAMETERS TABLE

Par.	Description	Range	Def.	Notes
d1	Differential 1	Probe limit	-1	
d2	Differential 2	Probe limit	-1	
db	Neutral zone	1/0,1 ... Probe limit	1	
LS1	Low/minimum set 1	Probe limit	min.	
LS2	Low/minimum set 2	Probe limit	min.	
HS1	High/Maximum set 1	Probe limit	Max.	
HS2	High/Maximum set 2	Probe limit	Max.	
Pb	Proportional band	1/0,1 ... Probe limit	40	
It	Integral time	0 ... 999 sec.	300	
dt	Derivative time	0 ... 999 sec.	30	
rSt	Manual reset	Probe limit	0	
od	Outputs delay	0 ... 500 sec.	0	
Ct	Cycle time	1 ... 500 sec.	20	
drb	Restart band Dynamic Set	0 ... Probe limit	0	
dSI	Dynamic Set increment	0 ... Probe limit	0	
dSt	Dynamic Set increment interval	1 ... 999 sec.	1	
Lci	Lower limit for normalized signal input	-99 ... 999	-99	
Hci	Higher limit for normalized signal input	-99 ... 999	999	
CAL	Calibration	-99 ... +999	0	
Ft	Control mode	on - Pi - nr	Pi	
PSE	Input probe	Tc: FE - Cr - rh Rtd: Pt - Ni	Tc: FE Rtd: Pt	
OCO	Sets connection	di - in	in	
HC1	Output 1 operating mode	H - C	H	
HC2	Output 2 operating mode	H - C	H	
dP	Decimal point	on - oF	oF	
rou	Unit of measurement	°C - °F	°C	
tun	Autotuning	y - n	n	
hdd	Half digit display	y - n	n	
tAb	Fixed parameter	---	---	

7 - PROBLEMS, MAINTENANCE AND WARRANTY

ERRORS SIGNALLING: The instrument shows the error message "EEE" , when the probe is interrupted or in overrange, or "- - -" when the probe (PTC, RTD or normalised signals) is in short-circuit or underrange; in this case verify the correct probe wiring with the instrument and afterward proceed to verify itself. In the error condition all the outputs are deactivated.

HOW TO CLEAN: We recommend to avoid abrasive cleaners or containing solvents which could damage the instrument.

WARRANTY AND REPAIRS: The instrument is under warranty against construction vices or defected material, noticed within 12 months from delivery date. The warranty is limited to the repairs or to the substitution of the instrument. The eventual opening of the housing, the violation of the instrument or the wrong use and installation of the product means the automatically decay of the warranty. In case of defected instrument, noticed in warranty period or out of warranty, do contact our sales

department to obtain the shipment authorisation. The defected product must be shipped to TECNOLOGIC with the detailed description of the failures found and without any fees or charge for Tecnologic, safe different agreements.