



TX6 Thermo Expansion Valves Technical Data

Document Nr.: 3.5.011/E -
Replaces doc.: -
Date: 20.06.2002

ALCO's TX6 series of Thermo[®]-Expansion Valves are designed for air conditioning, chillers, rooftops, close control, A/C transportation, heat pumps, industrial cooling process and commercial refrigeration applications. The TX6 is ideal for those applications requiring hermetic / compact size combined with stable and accurate control over wide load and evaporating temperature ranges.

Features

- Compact size
- Hermetic design
- Six sizes up to 87 kW (R 407C)
- Brazing connections with straight through configuration
- Long life laser welded stainless steel power element resists corrosion
- Large diaphragm eliminates disturbances to the valve and provides smoother and consistent valve control
- Balance port construction for constant superheat operation over a wide application range under variation of condensing pressure
- Bi-flow capability for heat pump applications
- Tailored charges for different applications
- External equalizer
- External superheat adjustment
- Brass body

Operating principle

Thermo[®]-Expansion Valves control the superheat of refrigerant vapour at the outlet of the evaporator. They act as a throttle device between the high and low pressure sides of refrigeration system and ensure the rate of refrigerant flow into the evaporator exactly matches the rate of evaporation of liquid refrigerant. Thus the evaporator is fully utilized and no liquid refrigerant may reach the compressor.

When the actual superheat is higher than the setpoint, thermo[®] expansion valve feeds the evaporator with more liquid refrigerant. Likewise, the valve decreases the refrigerant flow to the evaporator when the actual superheat is lower than the set point.

Construction

The valve body is made from brass. Connections in a straight through configuration. The diaphragm movement is transferred to a steel metering pin. When the charge pressure increases, the diaphragm will be deflected downward and this motion will be transferred to the pin. The pin will then lift from seat and the liquid can pass through orifice.

The pin design gives the balance port feature. Balance port design will eliminate the undesirable variable influence of inlet pressure i.e. condensing pressure during different air ambient temperature in systems with air cooled condenser.

The balance port design is only available in one direction as arrow indicates on the valve. This means, when the valve operates as Bi-flow in heat pump applications, the advantage of balance port is given in cooling or heating mode.



TX6

A spring opposes the force underneath the pin and its tension can be adjusted by the external stem. The static superheat can be adjusted by rotation of the stem. Static superheat increases by turning the stem clockwise and decreased by turning the stem counter clockwise.

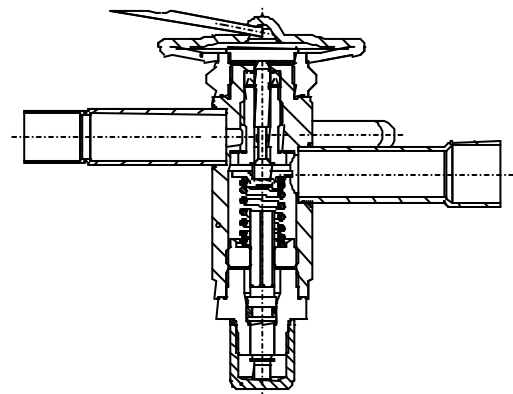

Description of bulb charges

The application ranges of Thermo[®] expansion valves are heavily influenced by the selected charge.

Liquid charges

The behaviour of Thermo[®]-Expansion Valves with liquid charges is exclusively determined by temperature changes at the bulb and not subject to any cross-ambient interference. They feature a fast



TX6

Thermo Expansion Valves

Document Nr.: A3.5.011/E -
 Replaces doc.: -
 Date: 20.06.2002

response time and thus react quickly in the control circuit. Liquid charges **cannot incorporate MOP functions**. The maximum bulb temperature is limited and shall not exceed the values, shown in the following table:

Table 1

Refrigerant/Charge	Maximum bulb temperature
R 134a /M0	88°C
R 407C /N0	71°C
R 22 /H0	71°C
R 404A & R 507 /S0	66°C

Table 2: Consideration for TXVs with liquid charge

Application	Recommendation
Heat pumps with reversible flow for heating/cooling	Not recommended
Hot gas defrost	-Use of cold gas from receiver for defrost -Piping arrangement with hot gas entry into the inlet of the evaporator
Other	No restriction

Gas charges

The behaviour of Thermo®-Expansion Valves with gas charges will be determined by the lowest temperature at any part of the expansion valve (power assembly, capillary tube or bulb). If any parts other than the bulb are subject to the lowest temperature, malfunction of the expansion valve may occur (i.e. erratic low pressure or excessive superheat). ALCO TX6 with gas charges **always feature MOP functions** and include ballasted bulbs. Ballast in the bulb leads to slow opening and fast closure of the valve. Maximum bulb temperature is 120°C.

MOP (Maximum Operating Pressure)

MOP functionality is somewhat similar to the application of a crankcase pressure regulator.

Evaporator pressures are limited to a maximum value to protect compressor from overload conditions.

MOP selection should be within maximum allowed low pressure rating of the compressor and should be at approximately 3 K above maximum evaporating temperature.

Table 3: MOP value, gas charge

MOP			Upper limit of evaporating temperature °C				
Code	bar	°C	R407C	R22	R134a	R404A	R507
N1	6.9	+17	+14	-	-	-	-
H1	6.9	+15	-	+12	-	-	-
M1	3.8	+14	-	-	+10	-	-
S1	2.8	-14	-	-	-	-18	-
S1	2.8	-15	-	-	-	-	-20

Note: All pressures are gauge pressure

Performance of TXV with MOP function, gas charge

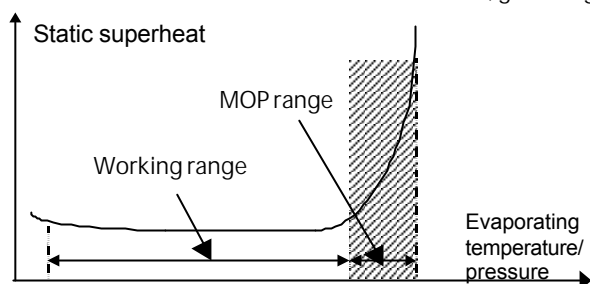

Valve operates as superheat control in normal working range and operates as pressure regulator within MOP range.

Practical hints:

Superheat adjustments influence the MOP:

Increase of superheat: decrease of MOP

Decrease of superheat: increase of MOP

Subcooling

Subcooling generally increases the capacity of a refrigeration system and may be accounted for when dimensioning an expansion valve by applying the correction factor K_f . The capacity corrections for evaporating temperature, condensing temperature and subcooling are all incorporated in K_f . These are in particular the liquid density upstream from the expansion valve, the different enthalpies of liquid and vapour phase refrigerants as well as certain part of flash gas after expansion. The percentage of flash gas differs with various refrigerants and depends on system conditions.

Heavy subcooling results in very small flash gas amounts and therefore **increases expansion valve capacities**. These conditions are not covered by K_f . Likewise, small flash gas amounts lead to reduced evaporator capacities and may result in substantial discrepancies between the capacities of the Thermo®-Expansion Valve and the evaporator. These effects must be considered during component selection when designing refrigeration circuits. In cases when subcooling exceeds 15 K, sizing of TXV should be modified accordingly. The **field practice** indicates the following correction factors can be used to compensate the effect of the subcooling (liquid hammering) in addition to the use of correction factors K_f , and $K_{\Delta p}$.

Subcooling	20K	30K	40K	50K	60K
Correction factor	0,8	0,7	0,6	0,5	0,4

ALCO CONTROLS will be happy to assist you. Please contact application engineering department.



TX6 Thermo Expansion Valves

Document Nr.: A3.5.011/E -
Replaces doc.: -
Date: 20.06.2002

Heat pump applications

There are several ways to apply an expansion valve in a heat pump. The following figures are showing the most popular applications:

1) System with two expansion valves, single Bi-flow filter dryer and two check valves

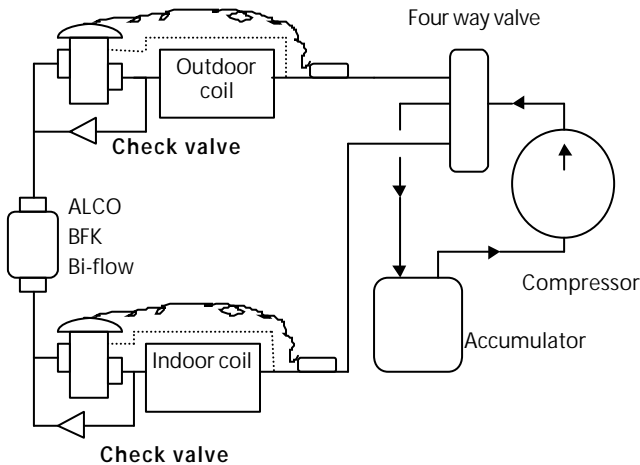

This type of system employs two expansion valves and two check valves. In this type of application, the charge of expansion valves should be able to withstand the high temperatures during reverse flow. Expansion valves with liquid charge are not recommended due limited bulb temperature below hot gas temperature.

2) System with single Bi-flow expansion Valve and Alco Bi-flow filter dryer(s) BFK

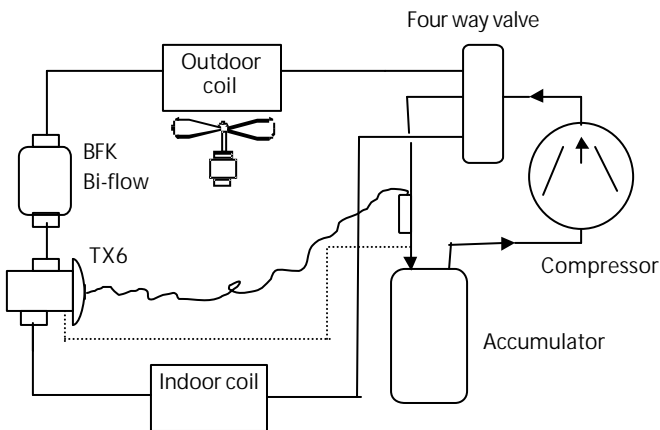

3) System with single Bi-flow expansion Valve and Alco suction filter dryer ASD

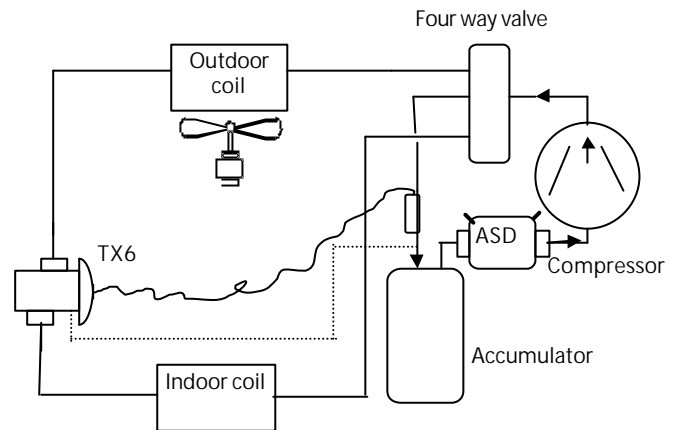

Bi-flow application

For application of TX6 in Bi-flow as single TXV in heat pumps, the following subjects need to be considered:

- TXV is balance port only in normal flow direction but not in reverse flow direction
- Inlet pressure in reverse flow act on valve pin as closing force. This effect is more significant at higher inlet pressure and lower evaporating temperature
- This effect will prevent the valve from desired opening percentage in reverse flow dependant to port size of valve, inlet pressure and evaporating temperature

Based on the above facts, it is necessary to consider the selection of TX6 in Bi-flow application. The following curves and table are as guidance for proper selection of TX6 in Bi-flow application.

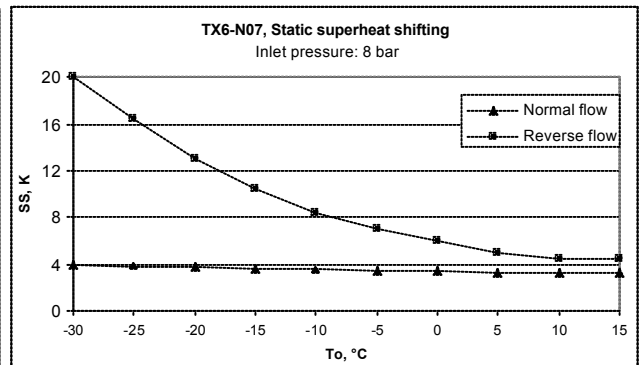
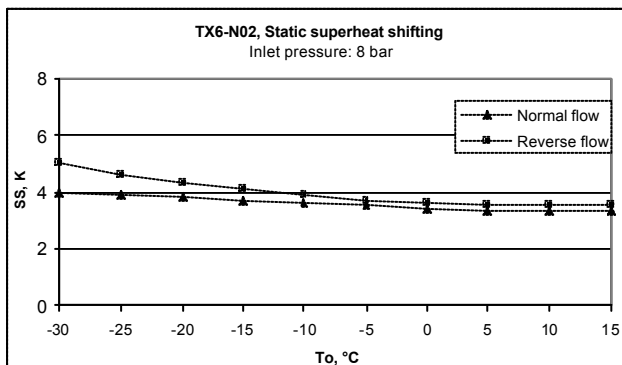



TX6

Thermo Expansion Valves

Document Nr.: A3.5.011/E -
 Replaces doc.: -
 Date: 20.06.2002

Size of valve	Condition in reverse flow	Impact on operation of valve	Application of valve in Bi-flow	Consideration for performance improvement
Small port size (TX6-..2/.3)	High or low operating inlet pressure	Negligible	Recommended	None
	High evaporating temperature	Negligible		
	Low evaporating temperature	Slightly increase of superheat		
Large port size (TX6-..4/.5/.6/.7)	High or low operating inlet pressure	Increase of superheat	This needs to be evaluated. *	- Lower system capacity in reverse vs. normal flow - Reduction of compressor capacity - Oversized valve
	Higher evaporating temperature	Increase of superheat	This needs to be evaluated. *	
	Lower evaporating temperature	Significant increase of superheat	Not recommended	No solution

*) During system design and prototype unit test.

Other remarks:

Subjects to be considered in Bi-flow applications:

- In an air to water (liquid) systems, it may require a receiver in order to hold excessive refrigerant in one mode of operation
- Do not install the Bulb of TXV between accumulator and compressor

- It is possible to install several Bi-flow filter dryers in parallel in system with larger capacity
- It is important to provide proper refrigerant distribution through liquid distributor at the inlet of evaporator due to distance between TXV and distributor

Static superheat setting

The factory setting of a TX6 is made with the valve pin just starting to move away from the seat. The superheat increment necessary to get the pin ready to move is called static superheat (SS). An increase of superheat over and beyond the static superheat (factory setting) is necessary for the valve pin to open to its rated capacity. This additional superheat is known as gradient or opening superheat (OS).

The working superheat (WS), which can be measured in the field, is the sum of static superheat and opening superheat.

The opening superheat of TXV varies if the selected valve operates at higher or lower capacities than the rated capacity. It is highly recommended to select the valve according to the rated capacity. Using reserve capacity leads to larger opening superheat and longer pull down time during start-up or after defrost.

Selecting a larger valve than required in a system may lead to smaller opening superheat and/or hunting of TXV.

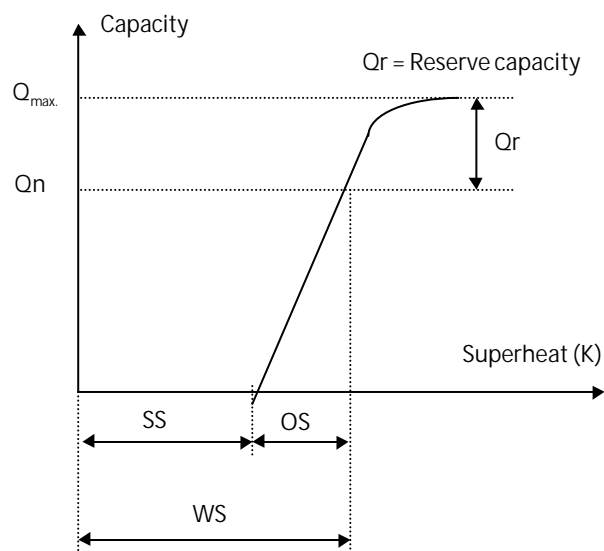

$Q_r \approx 15\%$ for TX6-..2/3/4/5/6

$Q_r \approx 10\%$ for TX6-..7



TX6 Thermo Expansion Valves

Document Nr.: A3.5.011/E -
Replaces doc.: -
Date: 20.06.2002

Standard superheat setting (TX2 / TX3)

Charge	Refrigerant	Conditions of setting	Setting	Given	
		Inlet pressure into valve	Bulb temperature	Nominal static superheat (SS)	Nominal opening superheat (OS*)
Liquid (No MOP)	R 134a	7.6 bar	0°C	3.3 K	5.5
	R 407C	8.6 bar			4
	R 22			4	
	R 404A			4 K	3.5
	R 507	4 K		3.5	
MOP 3.8 bar	R 134a	7.6 bar	-17.8°C	3.3 K	5.5
MOP 6.9 bar	R 407C	8.6 bar			4
	R 22				4
MOP 2.8 bar	R 404A		-17.8°C	4 K	3.5
	R 507		-17.8°C	4 K	3.5

*) The given opening superheats valid when the capacity of selected valve is equal to the capacity of system at design / operating conditions. Note : All pressures are gauge pressure.

Nomenclature and identification

TX6 - N 1 7

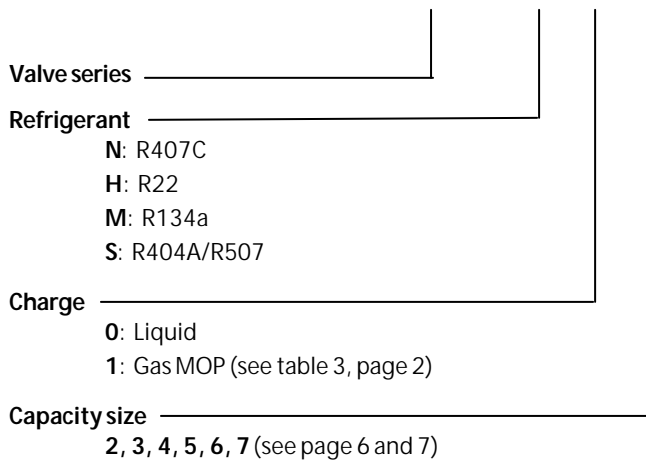



TX6
Thermo Expansion Valves

Document Nr.: A3.5.011/E -
Replaces doc.: -
Date: 20.06.2002

Selection table

Refrigerant	Nominal capacity Qn kW	Adjustable with standard setting				Connection size	
		Without MOP		With MOP *)		Equalizer	Inlet x Outlet
		Type	PCN	Type	PCN		
R 407C	14.4	TX6-N02	801 651	TX6-N12	801 655	Ext. 1/4"	12mmX16mm
	14.4	TX6-N02	801 653	TX6-N12	801 657	Ext. 1/4"	1/2" x 5/8"
	25.6	TX6-N03	801 652	TX6-N13	801 656	Ext. 1/4"	12mmX16mm
	25.6	TX6-N03	801 654	TX6-N13	801 658	Ext. 1/4"	1/2" x 5/8"
	35.7	TX6-N04	801 659	TX6-N14	801 667	Ext. 1/4"	16mmX22mm
	35.7	TX6-N04	801 663	TX6-N14	801 671	Ext. 1/4"	5/8" x 7/8"
	45.2	TX6-N05	801 660	TX6-N15	801 668	Ext. 1/4"	16mmX22mm
	45.2	TX6-N05	801 664	TX6-N15	801 672	Ext. 1/4"	5/8" x 7/8"
	66.9	TX6-N06	801 661	TX6-N16	801 669	Ext. 1/4"	22mmX28mm
	66.9	TX6-N06	801 665	TX6-N16	801 673	Ext. 1/4"	7/8" x 1-1/8"
	87.3	TX6-N07	801 662	TX6-N17	801 670	Ext. 1/4"	22mmX28mm
	87.3	TX6-N07	801 666	TX6-N17	801 674	Ext. 1/4"	7/8" x 1-1/8"
R 22	13.3	TX6-H02	801 551	TX6-H12	801 555	Ext. 1/4"	12mmX16mm
	13.3	TX6-H02	801 549	TX6-H12	801 553	Ext. 1/4"	1/2" x 5/8"
	23.7	TX6-H03	801 552	TX6-H13	801 556	Ext. 1/4"	12mmX16mm
	23.7	TX6-H03	801 550	TX6-H13	801 554	Ext. 1/4"	1/2" x 5/8"
	33.0	TX6-H04	801 585	TX6-H14	801 593	Ext. 1/4"	16mmX22mm
	33.0	TX6-H04	801 581	TX6-H14	801 589	Ext. 1/4"	5/8" x 7/8"
	41.8	TX6-H05	801 586	TX6-H15	801 594	Ext. 1/4"	16mmX22mm
	41.8	TX6-H05	801 582	TX6-H15	801 590	Ext. 1/4"	5/8" x 7/8"
	61.9	TX6-H06	801 587	TX6-H16	801 595	Ext. 1/4"	22mmX28mm
	61.9	TX6-H06	801 583	TX6-H16	801 591	Ext. 1/4"	7/8" x 1-1/8"
	80.8	TX6-H07	801 588	TX6-H17	801 596	Ext. 1/4"	22mmX28mm
	80.8	TX6-H07	801 584	TX6-H17	801 592	Ext. 1/4"	7/8" x 1-1/8"
R 134a	10.3	TX6-M02	801 543	TX6-M12	801 547	Ext. 1/4"	12mmX16mm
	10.3	TX6-M02	801 541	TX6-M12	801 545	Ext. 1/4"	1/2" x 5/8"
	18.4	TX6-M03	801 544	TX6-M13	801 548	Ext. 1/4"	12mmX16mm
	18.4	TX6-M03	801 542	TX6-M13	801 546	Ext. 1/4"	1/2" x 5/8"
	25.6	TX6-M04	801 569	TX6-M14	801 577	Ext. 1/4"	16mmX22mm
	25.6	TX6-M04	801 565	TX6-M14	801 573	Ext. 1/4"	5/8" x 7/8"
	32.5	TX6-M05	801 570	TX6-M15	801 578	Ext. 1/4"	16mmX22mm
	32.5	TX6-M05	801 566	TX6-M15	801 574	Ext. 1/4"	5/8" x 7/8"
	48.1	TX6-M06	801 571	TX6-M16	801 579	Ext. 1/4"	22mmX28mm
	48.1	TX6-M06	801 567	TX6-M16	801 575	Ext. 1/4"	7/8" x 1-1/8"
	62.8	TX6-M07	801 572	TX6-M17	801 580	Ext. 1/4"	22mmX28mm
	62.8	TX6-M07	801 568	TX6-M17	801 576	Ext. 1/4"	7/8" x 1-1/8"

Nominal capacities at +38°C saturated condensing temperature, +4°C saturated evaporating temperature and 1 K subcooling at the inlet of the expansion valve. Valve selection for other operating conditions see pages 7 to 11.

*) See table 3 on page 2 for MOP values.



TX6

Thermo Expansion Valves

Document Nr.: A3.5.011/E -
 Replaces doc.: -
 Date: 20.06.2002

Selection table

Refrigerant	Nominal capacity Q_n kW	Adjustable with standard setting				Connection size	
		Without MOP		With MOP *)		Equalizer	Inlet x Outlet
		Type	PCN	Type	PCN		
R404A R507	9.4	TX6-S02	801 559	TX6-S12	801 563	Ext. 1/4"	12mmX16mm
	9.4	TX6-S02	801 557	TX6-S12	801 561	Ext. 1/4"	1/2" x 5/8"
	16.7	TX6-S03	801 560	TX6-S13	801 564	Ext. 1/4"	12mmX16mm
	16.7	TX6-S03	801 558	TX6-S13	801 562	Ext. 1/4"	1/2" x 5/8"
	23.3	TX6-S04	801 601	TX6-S14	801 609	Ext. 1/4"	16mmX22mm
	23.3	TX6-S04	801 597	TX6-S14	801 605	Ext. 1/4"	5/8" x 7/8"
	29.5	TX6-S05	801 602	TX6-S15	801 610	Ext. 1/4"	16mmX22mm
	29.5	TX6-S05	801 598	TX6-S15	801 606	Ext. 1/4"	5/8" x 7/8"
	43.7	TX6-S06	801 603	TX6-S16	801 611	Ext. 1/4"	22mmX28mm
	43.7	TX6-S06	801 599	TX6-S16	801 607	Ext. 1/4"	7/8" x 1-1/8"
	57.0	TX6-S07	801 604	TX6-S17	801 612	Ext. 1/4"	22mmX28mm
	57.0	TX6-S07	801 600	TX6-S17	801 608	Ext. 1/4"	7/8" x 1-1/8"

Nominal capacities at +38°C saturated condensing temperature, +4°C saturated evaporating temperature and 1 K subcooling at the inlet of the expansion valve. Valve selection for other operating conditions see pages 7, 8 and 10.

*) See table 3 on page 2 for MOP values.

Dimensioning of Thermo[®]-Expansion Valves

To apply proper Thermo[®]-Expansion Valves on a system, the following design conditions must be available:

- Cooling capacity (Q_0)
- Effective pressure differential across TXV (Δp)
- Evaporating temperature / pressure
- Lowest possible condensing temperature / pressure
- Liquid temperature at the inlet of TXV
- Refrigerant type

To calculate the nominal capacity, the following formula has to be used:

$$\text{Cooling capacity} \times K_{\Delta p} \times K_t = \text{Nominal capacity of TXV}$$

+ Select K_t -factor according to refrigerant, liquid and evaporating temperature from tables on pages 9-11.

+ Determine effective pressure differential across the Thermo[®]-Expansion Valve using condensing pressure, subtract evaporating pressure and all other possible pressure losses. Select $K_{\Delta p}$ -factor from tables on pages 9-11.

Example 1

A valve has to be selected for the following conditions:

- Refrigerant R 22
- System cooling capacity 45.0 kW
- Evaporating temperature +5°C
- Lowest condensing temperature +30°C
- Liquid temperature +25°C
- Valve without MOP

Calculation:

- Theoretical pressure differential:
 Lowest condensing pressure is $P_c = 11.9$ bara at +30°C and evaporating pressure is $P_0 = 5.8$ bara at +5°C
 Differential pressure is $P_c - P_0 = 11.9 - 5.9 = 6$ bar

- Pressure losses:
 Across distributor = 1.0 bar
 Others in piping, solenoid valve, drier, sight glass, fitting, etc. = 0.5 bar
 Total pressure losses = 1 + 0.5 = 1.5
- Effective pressure differential across valve:
 $6.0 - 1.5 = 4.5$ bar
- Correction factors:
 Correction factor $K_{\Delta p}$ for the pressure differential 4.5 bar from table on page 9 for R 22
 $\Delta p = 4.5$ $K_{\Delta p} = 1.42$
 Correction factor K_t for liquid and evaporating temperature from table on page 9 for R 22 at +25°C / +5°C
 $K_t = 0.89$

- Calculation of nominal capacity $Q_0 \times K_{\Delta p} \times K_t = Q_n$
 $45 \times 1.42 \times 0.89 = 56.9$ kW.
 You can select the valve from table on page 6.

It is a TX6-H06 with a nominal capacity of 61.9 kW.



TX6 Thermo Expansion Valves

Document Nr.: A3.5.011/E -
Replaces doc.: -
Date: 20.06.2002

Dimensioning of Thermo[®]-Expansion Valves for systems with refrigerant R 407C

As opposed to single substances (e.g. R 22, R 134a etc.) where the phase change takes place at a constant temperature / pressure, the evaporation and condensation of zeotropic blend R407C is in a "gliding" form (e.g. at a constant pressure the temperature varies within a certain range) through evaporators and condensers.

The condensing / evaporating pressure must be determined at saturated temperatures (bubble / dew points) for dimensioning of Thermo[®]-Expansion Valves.

Example 2

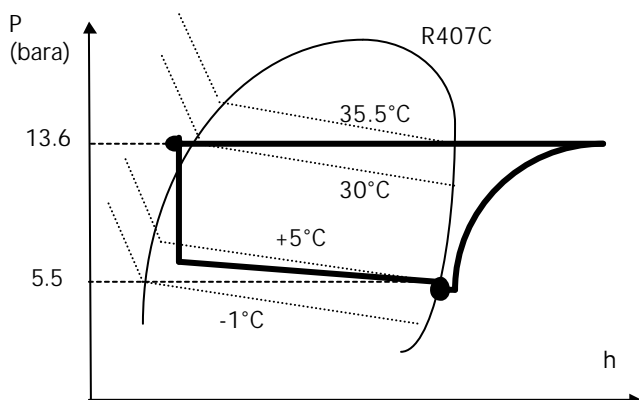

- System cooling capacity, R407C 55 kW
- Evaporating temperature (dew point) +5°C
- Lowest condensing temperature (bubble) +30°C
- Liquid temperature +25°C
- Valve without MOP

Calculation:

1. Theoretical pressure differential:
Differential pressure is $P_c - P_0 = 13.6 - 5.5 = 8.1$ bar
2. Pressure losses:
Across distributor = 1 bar
Others in piping, solenoid valve, drier, sight glass, fitting, etc. = 0.6 bar
Total pressure losses = $1 + 0.6 = 1.6$
3. Effective pressure differential across valve:
 $8.1 - 1.6 = 6.5$ bar
4. Correction factors:
Correction factor $K_{\Delta p}$ for the pressure differential 9.39 bar from table on page 9 for R 407C
 $\Delta p = 6.5$ bar $K_{\Delta p} = 1.31$
Correction factor K_t for liquid and evaporating temperature from table on page 9 for R 407C at +25°C / +5°C
 $K_t = 0.85$
5. Calculation of nominal capacity $Q_0 \times K_{\Delta p} \times K_t = Q_n$
 $55 \times 1.31 \times 0.85 = 61.2$
You can select the valve from table on page 6.
It is a TX6-N06 with a nominal capacity of 66.9 kW.

Example 3 for heat pump applications

A heat pump with following design conditions:

Cooling mode

- Cooling capacity, R 22 20 kW
 - Condensing temperature +45°C
 - Evaporating temperature +5°C
 - Liquid temperature 45°C
 - Valve without MOP
1. Theoretical pressure differential:
Differential pressure is $P_c - P_0 = 17.3 - 5.8 = 11.5$ bar
 2. Pressure losses:
Total pressure losses = 1.6
 3. Effective pressure differential across valve:
 $11.5 - 1.6 = 9.9$ bar
 4. Correction factors:
 $\Delta p = 9.9$ $K_{\Delta p} = 0.96$
At +5°C and 45°C $K_t = 1.07$
 5. Calculation of nominal capacity $Q_0 \times K_{\Delta p} \times K_t = Q_n$
 $20 \times 0.96 \times 1.07 = 20.5$ kW.
You can select the valve from table on page 6.

It is a TX6-H03 with a nominal capacity of 23.7 kW.

Heating mode (Reverse flow)

- Heating capacity, R 22 15 kW
 - Condensing temperature +30°C
 - Evaporating temperature -10°C
 - Liquid temperature +30°C
1. Theoretical pressure differential:
Differential pressure is $P_c - P_0 = 11.9 - 3.5 = 8.4$ bar
 2. Pressure losses:
Total pressure losses = 1.6
 3. Effective pressure differential across valve:
 $8.4 - 1.6 = 6.8$ bar
 4. Correction factors:
 $\Delta p = 6.8$ $K_{\Delta p} = 1.16$
At -10°C and 30°C $K_t = 0.99$
 5. Calculation of nominal capacity $Q_0 \times K_{\Delta p} \times K_t = Q_n$
 $15 \times 1.42 \times 0.89 = 17.2$ kW.
TX6-H03 has sufficient capacity in reverse flow for 17.2 kW.



TX6
Thermo Expansion Valves

Document Nr.: **A3.5.011/E -**
Replaces doc.: **-**
Date: **20.06.2002**

Liquid temperature entering valve °C	Correction factor K_t																Liquid temperature entering valve °C
	R22		Evaporating temperature °C												R22		
			+20	+15	+10	+5	0	-5	-10	-15	-20	-25	-30	-35	-40	-45	
+60			1.24	1.25	1.26	1.28	1.30	1.31	1.38	1.58	1.84	2.16	2.56	3.04	3.55	4.23	+60
+55			1.16	1.17	1.19	1.20	1.22	1.23	1.29	1.42	1.72	2.02	2.39	2.83	3.30	3.94	+55
+50			1.10	1.11	1.12	1.13	1.15	1.16	1.21	1.39	1.62	1.89	2.24	2.66	3.10	3.68	+50
+45			1.04	1.05	1.06	1.07	1.08	1.10	1.15	1.31	1.52	1.79	2.11	2.50	2.91	3.46	+45
+40			0.99	1.00	1.01	1.02	1.03	1.04	1.09	1.24	1.45	1.69	2.00	2.37	2.75	3.27	+40
+35			0.94	0.95	0.96	0.97	0.98	0.99	1.03	1.18	1.37	1.61	1.89	2.24	2.60	3.09	+35
+30			0.90	0.91	0.92	0.93	0.94	0.95	0.99	1.13	1.31	1.55	1.83	2.13	2.47	2.93	+30
+25			0.86	0.87	0.88	0.89	0.89	0.90	0.94	1.08	1.25	1.46	1.72	2.03	2.36	2.80	+25
+20			0.83	0.83	0.84	0.85	0.86	0.87	0.90	1.03	1.19	1.40	1.64	1.94	2.25	2.66	+20
+15				0.80	0.81	0.81	0.82	0.83	0.87	0.99	1.14	1.34	1.57	1.86	2.15	2.55	+15
+10					0.78	0.78	0.79	0.80	0.83	0.95	1.10	1.28	1.51	1.78	2.06	2.44	+10
+5						0.75	0.76	0.77	0.80	0.91	1.06	1.23	1.45	1.71	1.98	2.34	+5
0							0.73	0.74	0.77	0.88	1.02	1.19	1.39	1.65	1.90	2.25	0
-5								0.71	0.74	0.85	0.98	1.14	1.34	1.58	1.83	2.17	-5
-10									0.72	0.82	0.95	1.10	1.30	1.53	1.77	2.09	-10
Correction factor K_{Dp}																	
Δp (bar)	0.5	1	1.5	2	2.5	3	3.5	4	4.5	5	5.5	6	6.5	7	8	9	Δp (bar)
$K_{\Delta p}$	4.25	3.00	2.46	2.13	1.90	1.74	1.61	1.50	1.42	1.35	1.28	1.23	1.18	1.14	1.06	1.00	$K_{\Delta p}$
Δp (bar)	10	11	12	13	14	15	16	17	18	19	20	21	22	23	24	25	Δp (bar)
$K_{\Delta p}$	0.95	0.91	0.87	0.83	0.80	0.78	0.75	0.73	0.71	0.69	0.67	0.66	0.64	0.63	0.61	0.60	$K_{\Delta p}$

Liquid temperature entering valve °C	Correction factor K_t																Liquid temperature entering valve °C
	R407C		Evaporating temperature °C												R407C		
			+20	+15	+10	+5	0	-5	-10	-15	-20	-25					
+55			1.23	1.26	1.28	1.31	1.34	1.37	1.40	1.63	1.98	2.42					+55
+50			1.13	1.15	1.17	1.19	1.22	1.24	1.27	1.48	1.79	2.18					+50
+45			1.05	1.06	1.08	1.10	1.12	1.14	1.17	1.35	1.64	2.00					+45
+40			0.98	0.99	1.01	1.02	1.04	1.06	1.08	1.25	1.52	1.84					+40
+35			0.92	0.93	0.94	0.96	0.98	0.99	1.01	1.17	1.41	1.71					+35
+30			0.87	0.88	0.89	0.90	0.92	0.93	0.95	1.10	1.32	1.60					+30
+25			0.82	0.83	0.84	0.85	0.87	0.88	0.90	1.03	1.25	1.51					+25
+20			0.78	0.79	0.80	0.81	0.82	0.84	0.85	0.98	1.18	1.43					+20
+15				0.75	0.76	0.77	0.78	0.80	0.81	0.93	1.12	1.35					+15
+10					0.73	0.74	0.75	0.76	0.77	0.89	1.07	1.29					+10
+5						0.71	0.72	0.73	0.74	0.85	1.02	1.23					+5
0							0.69	0.70	0.71	0.81	0.98	1.18					0
Correction factor K_{Dp}																	
Δp (bar)	0.5	1	1.5	2	2.5	3	3.5	4	4.5	5	5.5	6	6.5	7	8	9	Δp (bar)
$K_{\Delta p}$	4.78	3.33	2.72	2.36	2.11	1.92	1.78	1.67	1.57	1.49	1.42	1.36	1.31	1.26	1.18	1.11	$K_{\Delta p}$
Δp (bar)	10	11	12	13	14	15	16	17	18	19	20	21	22	23	24	25	Δp (bar)
$K_{\Delta p}$	1.05	1.01	0.96	0.92	0.89	0.86	0.83	0.81	0.79	0.76	0.75	0.73	0.71	0.70	0.68	0.67	$K_{\Delta p}$



TX6
Thermo Expansion Valves

Document Nr.: **A3.5.011/E -**
Replaces doc.: **-**
Date: **20.06.2002**

Liquid temperature entering valve °C	Correction factor K_t															Liquid temperature entering valve °C	
	Evaporating temperature °C																
	R404A																
			+20	+15	+10	+5	0	-5	-10	-15	-20	-25	-30	-35	-40	-45	
+60			1.64	1.69	1.74	1.81	1.88	1.96	2.06	2.43	2.95	3.56	4.37	5.38	6.71	8.47	+60
+55			1.38	1.42	1.46	1.50	1.55	1.61	1.68	1.96	2.36	2.83	3.43	4.16	5.12	6.34	+55
+50			1.20	1.23	1.26	1.30	1.34	1.38	1.43	1.67	1.99	2.37	2.85	3.43	4.18	5.14	+50
+45			1.07	1.10	1.12	1.15	1.18	1.22	1.26	1.46	1.74	2.05	2.46	2.95	3.57	4.35	+45
+40			0.97	0.99	1.02	1.04	1.07	1.09	1.13	1.30	1.55	1.82	2.17	2.59	3.13	3.80	+40
+35			0.90	0.91	0.93	0.95	0.97	1.00	1.02	1.18	1.40	1.64	1.96	2.33	2.80	3.38	+35
+30			0.83	0.84	0.86	0.88	0.90	0.92	0.94	1.08	1.28	1.50	1.78	2.11	2.53	3.05	+30
+25			0.77	0.79	0.80	0.82	0.83	0.85	0.87	1.00	1.18	1.39	1.64	1.94	2.32	2.79	+25
+20			0.73	0.74	0.75	0.77	0.78	0.80	0.81	0.94	1.10	1.29	1.52	1.80	2.15	2.58	+20
+15				0.70	0.71	0.72	0.73	0.75	0.76	0.88	1.03	1.21	1.42	1.68	2.00	2.40	+15
+10					0.67	0.68	0.69	0.71	0.72	0.83	0.97	1.13	1.34	1.58	1.88	2.25	+10
+5						0.65	0.66	0.67	0.68	0.78	0.92	1.07	1.26	1.49	1.77	2.11	+5
0							0.63	0.64	0.65	0.75	0.88	1.02	1.20	1.41	1.67	2.00	0
-5								0.61	0.62	0.71	0.83	0.97	1.14	1.34	1.59	1.90	-5
-10									0.60	0.68	0.80	0.93	1.09	1.28	1.52	1.81	-10
Correction factor $K_{\Delta p}$																	
Δp (bar)	0.5	1	1.5	2	2.5	3	3.5	4	4.5	5	5.5	6	6.5	7	8	9	Δp (bar)
$K_{\Delta p}$	4.55	3.21	2.62	2.27	2.03	1.86	1.72	1.61	1.52	1.44	1.37	1.31	1.26	1.21	1.14	1.07	$K_{\Delta p}$
Δp (bar)	10	11	12	13	14	15	16	17	18	19	20	21	22	23	24	25	Δp (bar)
$K_{\Delta p}$	1.02	0.97	0.93	0.89	0.86	0.83	0.80	0.78	0.76	0.74	0.72	0.70	0.69	0.67	0.66	0.64	$K_{\Delta p}$

Liquid temperature entering valve °C	Correction factor K_t															Liquid temperature entering valve °C	
	Evaporating temperature °C																
	R507																
			+20	+15	+10	+5	0	-5	-10	-15	-20	-25	-30	-35	-40	-45	
+60			1.61	1.65	1.71	1.76	1.83	1.90	1.98	2.36	2.84	3.44	4.23	5.25	6.61	8.45	+60
+55			1.36	1.39	1.43	1.47	1.52	1.57	1.62	1.92	2.29	2.75	3.35	4.11	5.11	6.44	+55
+50			1.19	1.22	1.24	1.28	1.31	1.35	1.40	1.64	1.95	2.33	2.81	3.43	4.23	5.29	+50
+45			1.07	1.09	1.11	1.14	1.17	1.20	1.23	1.45	1.71	2.04	2.45	2.97	3.64	4.53	+45
+40			0.97	0.99	1.01	1.03	1.06	1.08	1.11	1.30	1.53	1.82	2.18	2.63	3.22	3.98	+40
+35			0.90	0.91	0.93	0.95	0.97	0.99	1.01	1.18	1.39	1.65	1.97	2.37	2.89	3.56	+35
+30			0.83	0.85	0.86	0.88	0.89	0.91	0.93	1.09	1.28	1.51	1.80	2.17	2.63	3.23	+30
+25			0.78	0.79	0.80	0.82	0.83	0.85	0.87	1.01	1.18	1.40	1.66	1.99	2.42	2.97	+25
+20			0.73	0.74	0.75	0.77	0.78	0.79	0.81	0.94	1.10	1.30	1.54	1.85	2.24	2.74	+20
+15				0.70	0.71	0.72	0.73	0.75	0.76	0.88	1.03	1.21	1.44	1.73	2.09	2.55	+15
+10					0.67	0.68	0.69	0.70	0.72	0.83	0.97	1.14	1.35	1.62	1.95	2.38	+10
+5						0.64	0.65	0.67	0.68	0.78	0.92	1.07	1.27	1.52	1.83	2.23	+5
0							0.62	0.63	0.64	0.74	0.87	1.02	1.20	1.43	1.73	2.10	0
-5								0.60	0.61	0.70	0.82	0.96	1.14	1.35	1.63	1.98	-5
-10									0.58	0.67	0.78	0.91	1.08	1.28	1.54	1.87	-10
Correction factor $K_{\Delta p}$																	
Δp (bar)	0.5	1	1.5	2	2.5	3	3.5	4	4.5	5	5.5	6	6.5	7	8	9	Δp (bar)
$K_{\Delta p}$	4.63	3.27	2.67	2.31	2.07	1.89	1.75	1.64	1.54	1.46	1.40	1.34	1.28	1.24	1.16	1.09	$K_{\Delta p}$
Δp (bar)	10	11	12	13	14	15	16	17	18	19	20	21	22	23	24	25	Δp (bar)
$K_{\Delta p}$	1.03	0.99	0.94	0.91	0.87	0.85	0.82	0.79	0.77	0.75	0.73	0.71	0.70	0.68	0.67	0.65	$K_{\Delta p}$



TX6

Thermo Expansion Valves

Document Nr.: A3.5.011/E -
 Replaces doc.: -
 Date: 20.06.2002

Liquid temperature entering valve °C	Correction factor K_t												Liquid temperature entering valve °C				
	Evaporating temperature °C																
	R134a						R134a										
	+20	+15	+10	+5	0	-5	-10	-15	-20	-25							
+60	1.27	1.30	1.33	1.36	1.40	1.44	1.48	1.75	2.08	2.46							+60
+55	1.18	1.21	1.23	1.26	1.29	1.33	1.36	1.60	1.90	2.25							+55
+50	1.10	1.13	1.15	1.17	1.20	1.23	1.26	1.48	1.76	2.07							+50
+45	1.04	1.06	1.08	1.10	1.12	1.15	1.17	1.38	1.63	1.92							+45
+40	0.98	0.99	1.01	1.03	1.05	1.08	1.10	1.29	1.52	1.79							+40
+35	0.92	0.94	0.96	0.97	0.99	1.01	1.03	1.21	1.43	1.68							+35
+30	0.88	0.89	0.91	0.92	0.94	0.96	0.98	1.14	1.35	1.58							+30
+25	0.83	0.85	0.86	0.87	0.89	0.91	0.92	1.08	1.27	1.49							+25
+20	0.80	0.81	0.82	0.83	0.85	0.89	0.88	1.02	1.21	1.41							+20
+15		0.77	0.78	0.79	0.81	0.82	0.84	0.97	1.15	1.34							+15
+10			0.75	0.76	0.77	0.78	0.80	0.93	1.09	1.28							+10
+5				0.73	0.74	0.75	0.76	0.89	1.04	1.22							+5
0					0.71	0.72	0.73	0.85	1.00	1.17							0
-5						0.69	0.70	0.82	0.96	1.12							-5
-10							0.68	0.79	0.92	1.07							-10

Correction factor K_{Dp}																	
Δp (bar)	0.5	1	1.5	2	2.5	3	3.5	4	4.5	5	5.5	6	6.5	7	7.5	8	Δp (bar)
$K_{\Delta p}$	3.50	2.48	2.02	1.75	1.57	1.43	1.32	1.24	1.17	1.11	1.06	1.01	0.97	0.94	0.90	0.88	$K_{\Delta p}$
Δp (bar)	8.5	9	9.5	10	10.5	11	11.5	12	13	14	15	16	17	18	19	20	Δp (bar)
$K_{\Delta p}$	0.85	0.83	0.80	0.78	0.76	0.75	0.73	0.72	0.69	0.66	0.64	0.62	0.60	0.58	0.57	0.55	$K_{\Delta p}$

Technical data

Compatibility	CFC. HCFC. HFC. Mineral and POE lubricants	CE-Marking	not allowed according to article 3.3 of pressure equipment directive 97/23 EC
Maximum working pressure	PS: 31 bar	Seat leakage	≤ 1% nominal capacity
Fluid group	II	Connection	ODF. copper
Medium temperature range	TS: -45 to 65°C	Charges	CFC free
Burst pressure	155 bar	Power element	Stainless steel

Charge	Refrigerant	Recommended evaporating temperature range °C	Maximum bulb temperature °C
N0	R 407C	-25 to +20	71
H0	R 22	-45 to +20	71
M0	R 134a	-25 to +30	88
S0	R 404A. R 507	-45 to +20	66
N1. MOP 6.9 bar	R 407C	-25 to +14	120
H1. MOP 6.9 bar	R 22	-45 to +12	120
M1. MOP 3.8 bar	R 134a	-25 to +10	120
S1. MOP 2.8 bar	R 404A	-45 to -18	120
S1. MOP 2.8 bar	R 507	-45 to -20	120



TX6

Thermo Expansion Valves

Document Nr.: A3.5.011/E -
 Replaces doc.: -
 Date: 20.06.2002

Shipping weights and pack quantities

	TX6
Pack quantity	12
Shipping weight. kg (Package)	0.65 (Individual)

Dimensions

TX6-....2/3

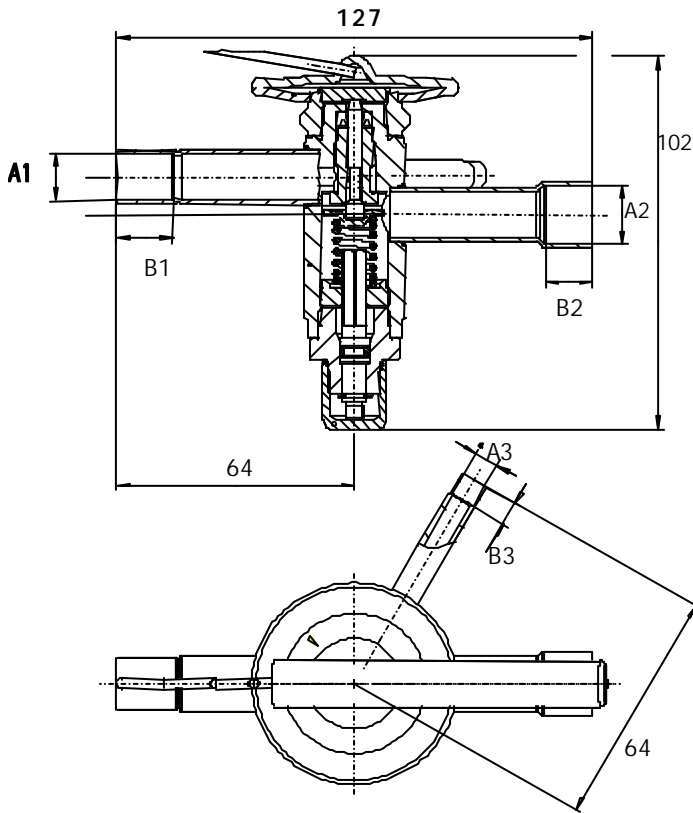

TX6-....4/5/6/

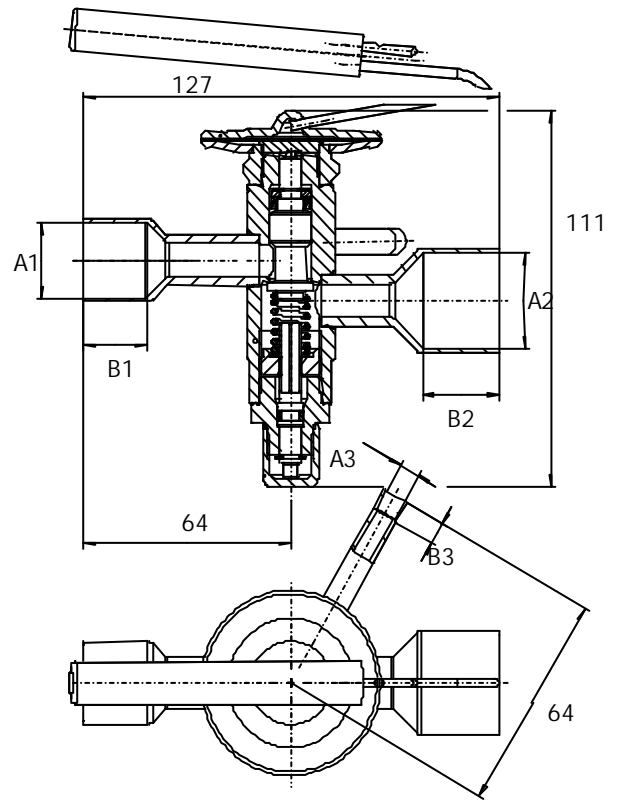

Roughing in dimensions (Nominal)

Type	A1 Ø	B1 mm	A2 Ø	B2 mm	A3 Ø	B3 mm	Capillary tube mm	Bulb	
								Diameter mm	Length mm
TX6-...2	1/2" & 12 mm	9	5/8" & 16 mm	13	1/4" & 6 mm	8	1500	13	89
TX6-...3	1/2" & 12 mm	9	5/8" & 16 mm	13	1/4" & 6 mm	8	1500	13	89
TX6-...4	5/8" & 16 mm	13	7/8" & 22 mm	19	1/4" & 6 mm	8	1500	13	89
TX6-...5	5/8" & 16 mm	13	7/8" & 22 mm	19	1/4" & 6 mm	8	1500	13	89
TX6-...6	7/8" & 22 mm	19	1-1/8" & 28 mm	23	1/4" & 6 mm	8	1500	13	89
TX6-...7	7/8" & 22 mm	19	1-1/8" & 28 mm	23	1/4" & 6 mm	8	1500	13	89



TX6 Thermo Expansion Valves

Document Nr.: A3.5.011/E -
Replaces doc.: -
Date: 20.06.2002

Saturation pressure table in bar absolute for several refrigerants

Temperature °C	R 407 C		R 22	R 134a	R 404 A		R 507
	Bubble point	Dew point	Bubble or dew point	Bubble or dew point	Bubble point	Dew point	Bubble or dew point
+70			29.83	21.17	33.34	33.01	
+65			26.87	18.89	31.95	31.84	32.91
+60			24.15	16.81	28.75	28.63	29.59
+55	24.91	22.48	21.64	14.91	25.8	25.66	26.54
+50	22.24	19.88	19.33	13.17	23.08	22.94	23.73
+45	19.79	17.52	17.21	11.59	20.58	20.44	21.14
+40	17.55	15.39	15.27	10.16	18.29	18.15	18.78
+35	15.5	13.46	13.5	8.87	16.2	16.06	16.62
+30	13.63	11.73	11.88	7.7	14.29	14.15	14.65
+25	11.93	10.17	10.41	6.65	12.55	12.42	12.86
+20	10.41	8.78	9.08	5.72	10.98	10.85	11.24
+15	9.03	7.54	7.88	4.88	9.56	9.44	9.78
+10	7.79	6.44	6.8	4.15	8.28	8.17	8.47
+8	7.33	6.03	6.4	3.88	7.8	7.7	7.98
+6	6.9	5.65	6.02	3.62	7.35	7.25	7.52
+4	6.48	5.28	5.66	3.38	6.92	6.82	7.08
+2	6.09	4.94	5.31	3.15	6.51	6.41	6.65
+0	5.71	4.61	4.98	2.93	6.11	6.01	6.25
-2	5.34	4.3	4.66	2.72	5.74	5.64	5.86
-4	5	4	4.36	2.53	5.38	5.29	5.5
-6	4.68	3.72	4.08	2.34	5.04	4.95	5.15
-8	4.37	3.46	3.81	2.17	4.71	4.63	4.82
-10	4.08	3.21	3.55	2.01	4.4	4.32	4.5
-12	3.8	2.97	3.31	1.86	4.11	4.03	4.2
-14	3.53	2.75	3.08	1.71	3.83	3.76	3.92
-16	3.29	2.54	2.86	1.58	3.57	3.5	3.65
-18	3.05	2.34	2.65	1.45	3.32	3.25	3.4
-20	2.83	2.16	2.46	1.33	3.09	3.02	3.15
-22	2.62	1.99	2.27	1.22	2.86	2.8	2.93
-24	2.42	1.82	2.1	1.12	2.65	2.59	2.71
-26	2.23	1.67	1.94	1.02	2.46	2.4	2.51
-28			1.78		2.27	2.21	2.32
-30			1.64		2.1	2.04	2.14
-32			1.51		1.93	1.88	1.98
-34			1.38		1.78	1.73	1.82
-36			1.26		1.63	1.58	1.67
-38			1.16		1.49	1.45	1.53
-40			1.05		1.37	1.33	1.4
-42			0.96		1.25	1.21	1.28
-44			0.87		1.14	1.1	1.17
-46			0.79		1.04	1	1.07

Use the bold values for selection of TXV (see page 8).



TX6
Thermo Expansion Valves

Document Nr.: A3.5.011/E -
Replaces doc.: -
Date: 20.06.2002

ALCO CONTROLS is not to be held responsible for erroneous literature regarding capacities, dimensions, applications, etc. stated herein. Products, specifications and data in this literature are subject to change without notice. The information given herein is based on technical data and tests which ALCO CONTROLS believes to be reliable and which are

in compliance with technical knowledge of today. It is intended only for use by persons having the appropriate technical knowledge and skills, at their own discretion and risk. Since conditions of use are outside of ALCO's control we can not assume any liability for results obtained or damages occurred due to improper application.

		Phone:	Fax:
ALCO CONTROLS	Benelux	+31 (0)492 472 416	+31 (0)492 472 621
Emerson Electric GmbH & Co	Denmark & Finland	+44 (0) 1635 876 161	+44 (0) 1635 877 111
Postfach 1251	Eastern Europe	+32 (0)87 305 061	+32 (0)87 305 506
Heerstraße 111	France	+33 (0)4 78 66 85 70	+33 (0)4 78 66 85 71
D-71332 Waiblingen	Germany	+49 (0)6109 6059 -0	+49 (0)6109 6059 40
Germany	Italy	+39 02 961 781	+39 02 961 788 888
Phone ...49-7151-509-0	Middle East & Africa	+32 (0)87 305 550	+32 (0)87 305 506
Fax ...49-7151-509-200	Poland	+48 225 485 205	+48 225 485 255
	Russia & Cis	+7 095 232 94 72	+7 095 232 03 56
www.alco-controls.com	Spain & Portugal	+34 93 41 23 752	+34 93 41 24 215
	Sweden & Norway	+44 (0) 1635 876 161	+44 (0) 1635 877 111
	UK & Ireland	+44 (0) 1635 876 161	+44 (0) 1635 877 111