

Ceiling / Dual Discharge

General Contents

General Features

This product is designed for use in cold rooms, air locks, laboratories, meat-cutting facilities, packing rooms and so on. The shape is generally low profile to save space in height; can be flush ceiling mounted, but may also be mounted on rods. Coolers like these work by drawing air in at the bottom (or at the top, if the product line is TFG) and then discharging it horizontally through the coils fitted on each side. The best performances are guaranteed if the cooler is placed in the centre of the room / dedicated area in which it is operating. These unit coolers are available in the following versions:

- Direct expansion evaporators
- Brine unit cooler
- Pump ammonia evaporator

Certifications and reliability

All DX unit coolers are guaranteed by Eurovent "Certify All". Alfa Laval quality systems fully comply with ISO 9001, and all of our products are manufactured in strict accordance with CE regulations.

Fin spacing

In our experience, fin spacing should correspond to both the goods stored and the room's air temperature, as follows:

Product	Fruit / Vegetables		Meat / Fish	Frozen food
Series	TFG	BFG		BFB
Room temperature	12 ÷ 0°C	10 ÷ 0°C		-18 ÷ -25°C
Fin spacing	4 mm	4 mm		7 mm
Series	TGL			TBL
Room temperature	10 ÷ 0°C			-18 ÷ -25°C
Fin spacing	4,5 mm			7 mm
Series			ITR	ITB
Room temperature			10 ÷ 0°C	-18 ÷ -25°C
Fin spacing			5 mm	7 mm

Capacity

The standard conditions are in accordance with EN 328. The cooling capacities stated in the catalogue are the nominal capacities for Qn (wet conditions), in compliance with Eurovent regulations. In standard Qst conditions (dry), the nominal capacities are calculated with the following formula:

$$Q_n = Q_{st} \times \text{Wet Coil Factor}$$

Standard conditions	Air Inlet Temp °C	Evaporation Temp. (Dew point) °C	R.H.	Wet Coil Factor
SC1	10	0	85%	1,35
SC2	0	-8	85%	1,15
SC3	-18	-25	95%	1,05
SC4	-25	-31	95%	1,01

The nominal capacities are calculated with refrigerant R404A. For

different refrigerants the following factors should be applied:

Refrigerant	SC1	SC2	SC3	SC4
R134a	0,93	0,91	0,85	-
R22	0,95	0,05	0,95	0,95
R507	0,97	0,97	0,95	0,95
R404A	1	1	1	1

See the fin material factors below:

Fin material	Factor
Aluminium	1
Coated Aluminium	0,97
Copper	1,03

Relative humidity ΔT

The cold room hygrometric conditions are defined by the room temperature and the working ΔT. At positive cold room temperatures ΔT has an influence on the relative humidity (RH).

Air throw

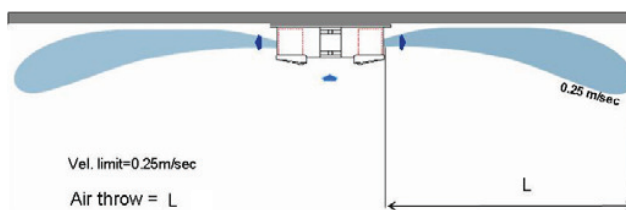

The values given in the tables are based on an air temperature of 20°C beneath a flat ceiling with no obstructions. The height and air circulation of the room can influence the air throw. The stated distances are based on a final air velocity of 0.25m/s. The value indicates the air flow from the unit to one side.

Data Sound

Lp(A) is the A-weighted sound pressure level in a room with an absorption area of 100 m² (Sabine), with the observation point at a distance of 5 m and 45° horizontally below the middle point of the fans. Lw(A) is the A-weighted sound power level measured according to EN13487; annex C.

m	1	2	3	4	5
dB (A)	6	4	2	1	0

Defrost

All our coolers come equipped with several different defrosting systems. For room temperatures where ice build-up is likely, and where the ambient room temperature is below 0°C, a unit with a defrosting system is needed



Test and cleaning

The coils are cleaned and dehydrated in order to remove any traces of oil. Each heat exchanger undergoes a pressure and leak test with dry air at 30 bar, before being supplied with a nitrogen pre-charge.

Guarantee

All our products are protected under warranty for 18 months from the shipping date. In the unlikely event of a defect occurring within the warranty period, please return the equipment or faulty part free of charge to us, where we will decide whether to repair or replace the goods . Unfortunately, We cannot take responsibility for damage caused by the misuse or incorrect installation of our products. Brochure subject to technical changes without prior notice



We recommend that you use the Alfa Select software for an exact thermal and mechanical design.



Top

Product description

Applications

These double air flux units are designed for use in cold rooms containing fresh goods with volumes ranging from 10-150m³. The units are designed for quick and easy maintenance with immediate access to key inspection areas. This series is available as an evaporator (DX or pump, HFC, NH₃,CO₂) and as a Brine unit cooler.

Standard design

Coil

Coil manufactured from corrugated aluminium fins and copper rippled tubes with a diameter of 12mm for DX evaporator, and smooth tubes with a nominal diameter of 12mm for Brine and 16mm for NH₃ units. Frame made from aluminium sheets.

Casing

The casing is available in two versions: aluminium or anti-shock plastic materials, suitable for applications where a high degree of hygiene is required.

Benefits

- Low power consumption fan motor
- Low noise level
- Compact design
- Easy maintenance and access
- Eurovent certified

Options

- 4 and 6-pole fan motors (230V/1ph)
- 4-pole fan motor (400V/3ph)
- Local safety switch wired
- Reheating coil
- Stainless steel tubes
- Pre-coated fins
- Cataphoresis treatment
- Many fin spacing options
- Drain-pipe flexible electrical heater
- Electric defrost
- Hot gas defrost



Fans

In standard execution, single-phase motor 230V-50HZ, protection class IP54 according to DIN 40050. Integrated thermo contacts provide reliable protection against overload. All motors are wired in on junction box as standard execution.

The fans are suitable for operation in air temp. application between -40°C and +40°C.

For air temperature lower than +20°C, the full load current (FLC) can be calculated by using the correction factor table. The overload protectors should have a 20% margin to accommodate fan motor supplier variations.

T [°C]	20	10	0	-10	-15	-20	-25	-30
Fc	1	1,04	1,08	1,12	1,14	1,16	1,18	1,2

Model	Capacity [SC2]	Capacity [SC3]	Airflow	Air Throw	P	Surface	Tube Volume	Noise	El. Power	Voltage	Current	Fan D.	No. fans	Connection	
														Inlet	Outlet
	kW	kW	m ³ /h	m	mm	m ²	dm ³	dB(A)	W	V	A	mm	-	mm	mm
TGL															
TGL31	1,57	1,25	1420	2x6	4,5	11,4	2,0	51	118	230	0,56	300	1	1/2" SAE	16 mm
TGL32	2,11	1,73	1320	2x5	4,5	15,3	2,3	51	118	230	0,56	300	1	1/2" SAE	16 mm
TGL33	3,24	2,6	2841	2x8	4,5	22,9	3,1	54	236	230	1,12	300	2	1/2" SAE	20 mm
TGL34	4,08	3,18	2640	2x8	4,5	30,5	4,6	54	236	230	1,12	300	2	1/2" SAE	20 mm
TGL35	5,22	4,27	4778	2x12	4,5	35,3	4,8	59	304	230	1,32	350	2	1/2" SAE	24 mm
TGL36	6,88	5,54	4461	2x12	4,5	47	6,3	59	304	230	1,32	350	2	1/2" SAE	24 mm
TGL37	8,01	6,34	7160	2x15	4,5	52,9	6,7	61	456	230	1,98	350	3	1/2" SAE	28 mm
TGL38	10,21	8,25	6692	2x14	4,5	70,5	8,3	61	456	230	1,98	350	3	5/8" SAE	28 mm
TBL															
TBL61	1,2	0,96	1471	2x6	7	7,5	2,0	51	118	230	0,56	300	1	1/2" SAE	16 mm
TBL62	1,91	1,57	1400	2x6	7	10	2,3	51	118	230	0,56	300	1	1/2" SAE	16 mm
TBL63	2,5	2,02	2941	2x9	7	15,1	3,1	54	236	230	1,12	300	2	1/2" SAE	20 mm
TBL64	3,42	2,7	2800	2x8	7	20,1	4,6	54	236	230	1,12	300	2	1/2" SAE	20 mm
TBL65	4,54	3,73	4971	2x12	7	23,2	4,8	59	304	230	1,32	350	2	1/2" SAE	24 mm
TBL66	5,93	4,82	4692	2x12	7	30,9	6,3	59	304	230	1,32	350	2	1/2" SAE	24 mm
TBL67	6,54	5,25	7449	2x15	7	34,8	6,7	61	456	230	1,98	350	3	1/2" SAE	28 mm
TBL68	8,65	7,04	7038	2x15	7	46,4	8,3	61	456	230	1,98	350	3	5/8" SAE	28 mm

*Nominal capacity according to ENV328 and Eurovent regulations (refrigerant R404A, $\Delta T1 = T_{\text{Inair}} - T_{\text{ev}}$). Use external equalised thermostatic expansion valve.

Top

Drawings

Model	Weight
	Kg
TGL31	23
TGL32	26
TGL33	36
TGL34	41
TGL35	50
TGL36	58
TGL37	71
TGL38	83
TBL61	22
TBL62	25
TBL63	34
TBL64	38
TBL65	47
TBL66	54
TBL67	67
TBL68	77

Top • TGL • TBL

Technical drawings showing dimensions for various models:

- TGL31 / TBL61:** Length 530, height 260, base offset 130, total length 740, height 235.
- TGL33 / TBL63:** Length 1030, height 268, total length 1240, height 235.
- TGL35 / TBL65:** Length 770, height 278, total length 1780, height 235.
- TGL37 / TBL67:** Length 770, 770, 800, total length 2550, height 292, height 235.

Additional details from the top view drawing:

- Top length: 995, 980
- Gas inlet: 1" GAS
- Ports: 20mm diameter

We reserve the right to change our technical data without prior notice.

Top

Options

Fan Motor



Different fan motors suitable for different installations
 6-pole, 230V/1 Ph
 4-pole, 400V/3 Ph

Model:
ALL APPLICATIONS
 All Models

Local safety switch wired

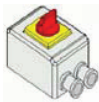

See Electrical Data Page.

Model:
ALL APPLICATIONS
 All Models

Reheating coil

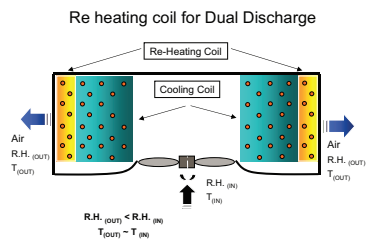

Use:
 It is an additional coil used for dehumidifying or heating the air outlet of the one or two rows There are two systems:

- Using warm water with minimal flow rate provides a small air temperature rise.
- Using electric heaters fixed into the finned tube coil.

Quick selection:

- Product available: Top
- Permanent 2 row tube for reheating coil.
- Coils sizes with reheating water.

Model:
ALL APPLICATIONS
 All Models

Coil Treatment / Material

Pre-coated fins: Epoxy-coated, pre-painted aluminium fins.
Cataphoresis treatment: An electrolytic process is achieved by submerging the coil in a paint bath, where it acts as a cathode and gets completely coated in an epoxy paint, which gives exceptional protection against corrosion. Recommended for alkaline or saline atmospheres.
 Applications: More information on corrosion prevention can be found in the Miscellaneous section

Model:
ALL APPLICATIONS
 All Models

Special fin spacing

Different fin spacings are available for the TBL and TGL series. Airflow and air throw are influenced by the different spacing variations.

Model:
ALL APPLICATIONS
 All Models

Cable electric heater

Application: While defrosting we recommend that you heat the discharge pipeline to prevent ice formation in the pipes. The flexible electrical heater can easily be placed inside the pipe. Two powers are available:
 70W (L=4m) and 100W (L=6m). Voltage 230V.

Model:
ALL APPLICATIONS
 All Models

Top

Electrical Data

Junction box for motors

TGL/TBL series

Function

Junction box complete with screw-on cover, cable glands and terminal strip.

General data

Material: Plastic

IP Protection Class: Min IP55

Colour: Grey RAL7035

Insulation class: II

Ambient Temp.: -25°C Max +50°C

Weight: 0,5 kg

Dimensions

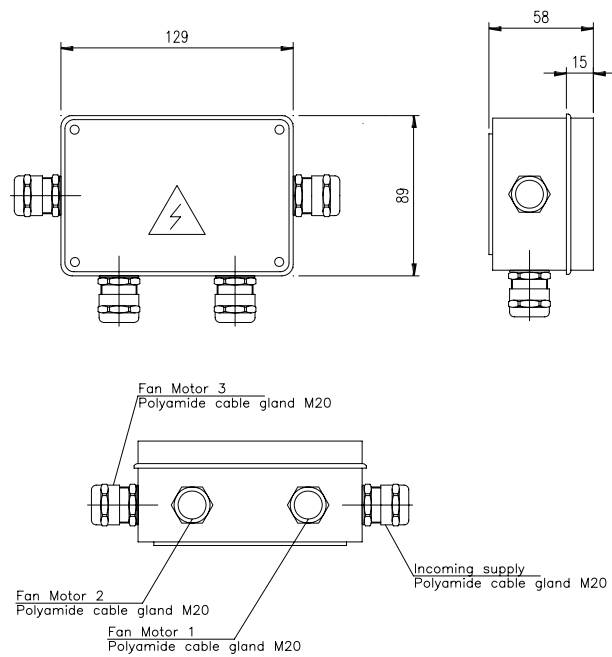

NOTE :

(1) N° OF MOUNTED CABLE IS ACCORDING TO ORDER

Electric wiring diagram

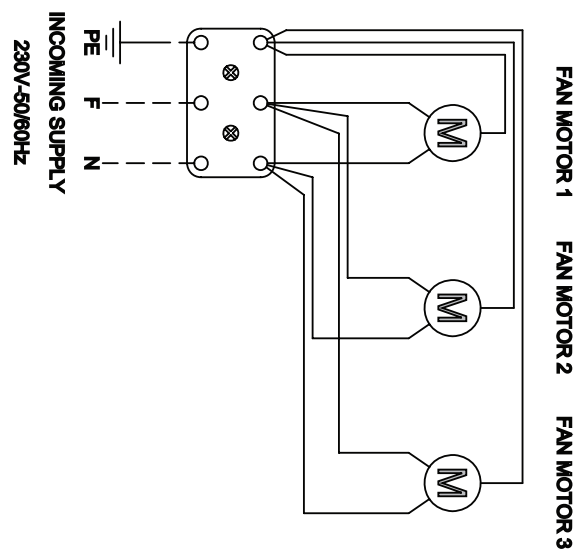

Junction box for "E" defrost

TGL/TBL series

Function

Junction box complete with screw-on cover, cable glands and terminal strip.

General data

Material: Plastic
 IP Protection Class: Min IP55
 Colour: Grey RAL7035
 Insulation class: II
 Ambient Temp.: -25°C Max +50°C
 Weight: 0,5 kg

Dimensions

Electric wiring diagram

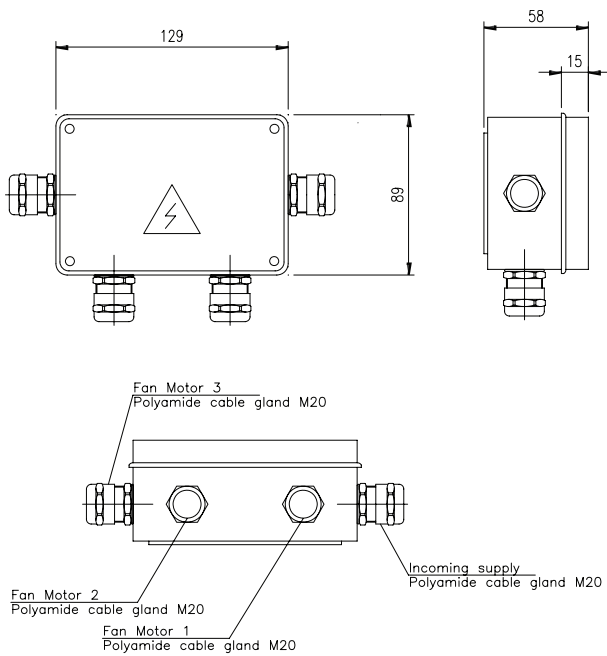

NOTE :
 (1) N° OF MOUNTED CABLE IS ACCORDING TO ORDER

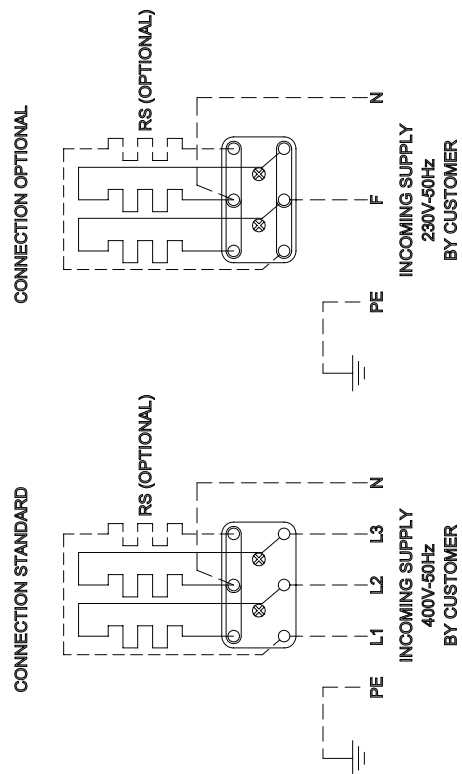

Top

Electric Heater

ALL SERIES

Function

The elements are designed to operate in a refrigeration field with high moisture rate.

Special care is taken in selecting the power supply, cables and insulation materials.

General data

Model	ELECTRICAL DEFROST		ELECTRICAL ELEMENT DRAIN LINE
	COIL		(Options)
	N° heater	P(W)	P(W)
TGL31	2	950	70
TGL32	2	950	70
TGL33	2	1900	70
TGL34	2	1900	70
TGL35	2	2900	70
TGL36	2	2900	70
TGL37	2	4400	70
TGL38	2	4400	70
TBL61	2	950	70
TBL62	2	950	70
TBL63	2	1900	70
TBL64	2	1900	70
TBL65	2	2900	70
TBL66	2	2900	70
TBL67	2	4400	70
TBL68	2	4400	70

We reserve the right to change our technical data without prior notice.

Top

Code description

Series	Room Temperature	Fin Spacing
TGL	Fruit and vegetables (from 0 to 10° C)	4,5 mm
TBL	Frozen food (from -18 to -25° C)	7 mm

	1	2	3	4	5
TGL	E	S	31	A	S

TGL	Green Line
TBL	Blue Line

1) Application

E	Direct Expansion Evaporator
W	Brine Unit Cooler

2) Noise Level

S	4-pole fan motor
L	6-pole fan motor

3) Progressive Number

31-38
61-68

4) Defrost

A	Air
E	Electric
HG	Hot Gas

5) Fan Motor

S	Single phase
D/Y	Three-phase

General Alfa Select Air Legend

Description 1		Description 2	
D	D fan cabling (three phase)	BSFT	Basic Switch Board + Speed Control Temp. + Signal
Y	Y fan cabling (three phase)	BI	Basic Switch Board + Frequency Converter (Inverter)
D/Y	D/Y fan cabling (three phase), single speed fan motor	BSI	Basic Switch Board + Frequency Converter (Inverter) + Signal
S	Single phase	C	Switch Board + Cooling fan
P	Packaged on a pallet	R	Switch Board + Resistor
CR	Packaged in a crate	F	Switch Board + Cooling fan + Resistor
BO	Packaged in a box	PT	Ammonia pump top
Feet	Feet-mounted	PB	Ammonia pump bottom
SW	Safety Switch	AL	Aluminium casing
CB	Terminal Box	SS	Stainless Steel casing
B	Basic Switch Board	AP	Pre-painted Aluminium casing
BS	Basic Switch Board + Signal	PL	Plastic casing
BP	Basic Switch Board + Step Control Pressure	E	Electrical defrost
BT	Basic Switch Board + Step Control Temperature	LE	Low Electrical defrost
BSP	Basic Switch Board + Step Control Pressure + Signal	A	Air Defrost
BST	Basic Switch Board + Step Control Temp. + Signal	HG	Hot Gas Defrost
BFP	Basic Switch Board + Speed Control Pressure	HG+E	Hot Gas Defrost + Electrical Defrost on drip tray
BFT	Basic Switch Board + Speed Control Temperature	W	Water Defrost
BSFP	Basic Switch Board + Speed Control Pres. + Signal	W+E	Water Defrost + Electrical Defrost on drip tray
		AL	Aluminium fin
		CU	Copper fin
		PR	Pre-coated fin
		SS	Stainless steel tube
		TH	Thermoguard treatment
		CF	Cataphoresis treatment
		SC	Sub-cooling circuit
		KW	Spray water kit
		FL	Flanges
		FH	Fan ring heater
		IS	Insulated Drip Tray
		RH	Reheating coil
		SR	Air socket adapter ring
		CW	Air throw fan cowling
		ER	120° elbow reducer
		HN	Hinged fan cowling

Note: valid for the entire product range

BFG/BFB

Product description

Applications

The double air flux series, designed for use in cold rooms for fresh and frozen goods ranging in volume from 100 to 800m³. The units are designed for quick and easy maintenance with immediate access to key inspection areas. This series is available as an evaporator (DX or pump, HFC NH₃, and CO₂) and as a Brine unit cooler.

Standard design

Coil

Coil manufactured from corrugated aluminium fins and copper rippled tubes with a diameter of 12mm for a DX evaporator and smooth tubes with a 12mm diameter for Brine and 16mm tubes for NH₃ units and CO₂ units. Frame made from aluminium sheets.

Casing

The casing is manufactured from pre-painted aluminium sheets (RAL 9010), which are protected by plastic film for extra protection during transit.

Benefits

- Low noise level
- Low air velocity
- Easy maintenance and access
- Eurovent certified

Options

- Pre-wired to main terminal box
- Motor fan 230V/1ph 50/60Hz, 4 and 6-pole
- Motor fan 400-460V/3ph 50/60Hz, 6/6-pole
- Local safety switch wired
- Reheating coil
- Pre-coated fins
- Cataphoresis treatment
- Stainless steel tube
- Many fin spacing options
- Stainless steel casing
- Insulated drip tray
- Electric defrost

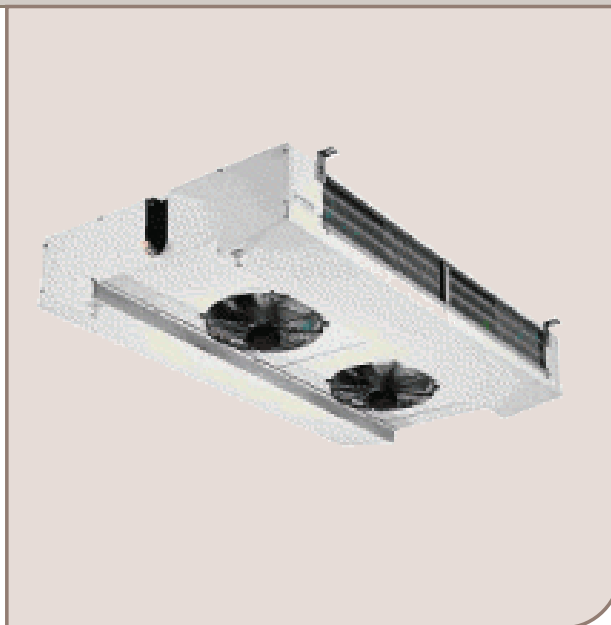

Fans

Three-phase motor 400V-50Hz, protection class IP 54 according to DIN 40050. Integrated thermo contacts provide reliable protection against overload.

The fans are suitable for operation in air temp. application between -40°C and +40°C.

For air temperature lower than +20°C, the full load current (FLC) can be calculated by using the correction factor table. The overload protectors should have a 20% margin to accommodate fan motor supplier variations.

T [°C]	20	10	0	-10	-15	-20	-25	-30
Fc	1	1,04	1,08	1,12	1,14	1,16	1,18	1,2

Model	Capacity [SC2]	Capacity [SC3]	Airflow	Air Throw	P	Surface	Tube Volume	Noise	El. Power	Voltage	Current	Fan D.	No. fans	Connection	
	kW	kW	m ³ /h	m	mm	m ²	dm ³	dB(A)	W	V	A	mm		Inlet	Outlet
BFG															
BFGE402B4	9,98	7,71	7391	2X12	4	67,5	7,1	60	474	400(D)	1,06	400	2	22 mm	35 mm
BFGE402C4	12,83	10,06	7111	2X11	4	101,2	10,6	60	474	400(D)	1,06	400	2	22 mm	35 mm
BFGE403B4	15,06	11,73	11098	2X14	4	101,2	10,6	62	711	400(D)	1,59	400	3	22 mm	42 mm
BFGE403C4	19,27	15,37	10656	2X14	4	151,9	15,9	62	711	400(D)	1,59	400	3	28 mm	42 mm
BFGE404B4	20,00	15,52	14797	2X17	4	135,00	14,1	63	948	400(D)	2,12	400	4	28 mm	42 mm
BFGE404C4	25,75	20,27	14208	2X16	4	202,5	21,1	63	948	400(D)	2,12	400	4	35 mm	54 mm
BFGE405B4	25,05	19,45	18496	2X19	4	168,7	17,6	64	1185	400(D)	2,65	400	5	35 mm	54 mm
BFGE405C4	32,30	25,28	17760	2X18	4	253,1	26,4	64	1185	400(D)	2,65	400	5	35 mm	54 mm
BFB															
BFBE402B7	5,48	4,32	3742	2X12	7	39,7	7,1	60	474	400(D)	1,06	400	2	22 mm	35 mm
BFBE402C7	9,68	7,20	7342	2X12	7	59,5	10,6	60	474	400(D)	1,06	400	2	22 mm	35 mm
BFBE403B7	8,25	6,55	5613	2X15	7	59,5	10,6	62	711	400(D)	1,59	400	3	22 mm	42 mm
BFBE403C7	14,57	10,90	11013	2X14	7	89,2	15,9	62	711	400(D)	1,59	400	3	22 mm	42 mm
BFBE404B7	11,04	8,40	7484	2X17	7	79,3	14,1	63	948	400(D)	2,12	400	4	22 mm	42 mm
BFBE404C7	19,57	14,72	14684	2X17	7	119,00	21,1	63	948	400(D)	2,12	400	4	28 mm	54 mm
BFBE405B7	13,79	10,55	9355	2X19	7	99,2	17,6	64	1185	400(D)	2,65	400	5	28 mm	54 mm
BFBE405C7	24,37	18,28	18337	2X18	7	148,7	26,4	64	1185	400(D)	2,65	400	5	35 mm	54 mm

*Nominal capacity according to ENV328 and Eurovent regulations (refrigerant R404A, $\Delta T_1 = T_{\text{Inair}} - T_{\text{ev}}$). Use external equalised thermostatic expansion valve.

TFG

Product description

Applications

Double air flux series, designed for use in working and packing areas, where low noise levels and low air velocity are required. Typical room volumes from 50 to 500m³. The units are designed for quick and easy maintenance with immediate access to key inspection areas. This series is available as an evaporator (DX or pump, HFC, NH₃ and CO₂) and as a Brine unit cooler.

Standard design

Coil

Coil manufactured from corrugated aluminium fins and copper rippled tubes with a diameter of 12mm for DX evaporator, and smooth tubes with a nominal diameter of 12mm for Brine and 16mm for NH₃ units. Frame made from aluminium sheets.

Casing

The casing is manufactured from pre-painted aluminium sheets (RAL 9010), which are protected by plastic film for extra protection during transit.

Benefits

- Low noise level
- Low air velocity
- Easy maintenance and access
- Eurovent certified

Options

- Pre-wired to main terminal box
- Motor fan 230V/1ph 50/60Hz, 4 and 6-pole
- Motor fan 400-460V/3ph 50/60Hz, 6/6-pole
- Local safety switch wired
- Reheating coil
- Pre-coated fins
- Cataphoresis treatment
- Stainless steel tube
- Many fin spacing options
- Stainless steel casing
- Insulated drip tray
- Electric defrost



Fans

Three-phase motor 400V-50HZ, protection class IP 54 according to DIN 40050. Integrated thermo contacts provide reliable protection against overload.

The fans are suitable for operation in air temp. application between -40°C and +40°C.

For air temperature lower than +20°C, the full load current (FLC) can be calculated by using the correction factor table. The overload protectors should have a 20% margin to accommodate fan motor supplier variations.

T [°C]	20	10	0	-10	-15	-20	-25	-30
Fc	1	1,04	1,08	1,12	1,14	1,16	1,18	1,2

Model	Capac- ity [SC2]	Capac- ity [SC3]	Airflow	Air Throw	P	Surface	Tube Volume	Noise	El. Power	Voltage	Current	Fan D.	No. fans	Connection mm	
	kW	kW	m ³ /h	m	mm	m ²	dm ³	dB(A)	W	V	A	mm		Inlet	Outlet
TFG															
TFGE401A4	2,24	1,79	2606	2X7	4	25,3	2,7	53	116	400(Y)	0,20	400	1	5/8" SAE	28 mm
TFGE401B4	4,52	3,48	3072	2X7	4	33,7	3,5	53	116	400(Y)	0,20	400	1	5/8" SAE	28 mm
TFGE402A4	4,51	3,62	5212	2X10	4	50,6	5,3	56	232	400(Y)	0,40	400	2	5/8" SAE	35 mm
TFGE402B4	9,11	7,07	6131	2X10	4	67,5	7,1	56	232	400(Y)	0,40	400	2	5/8" SAE	35 mm
TFGE403A4	6,81	5,16	7818	2X12	4	75,9	7,9	58	348	400(Y)	0,60	400	3	22 mm	42 mm
TFGE403B4	13,76	10,77	9196	2X12	4	101,2	10,6	58	348	400(Y)	0,60	400	3	22 mm	42 mm
TFGE404B4	18,29	14,26	12261	2X14	4	135,00	14,1	59	464	400(Y)	0,80	400	4	28 mm	48 mm
TFGE405B4	22,88	17,85	15326	2X15	4	168,7	17,6	60	580	400(Y)	1,00	400	5	35 mm	48 mm

*Nominal capacity according to ENV328 and Eurovent regulations (refrigerant R404A, $\Delta T_1 = T_{inair} - T_{ev}$). Use external equalised thermostatic expansion valve.

BFG/BFB,TFG

Drawings

Model	Dimensions				Weight Kg
	mm A	mm B	mm C	mm D	
BFG					
BFGE402B4	1975	1610	-	-	85
BFGE402C4	1575	1610	-	-	95
BFGE403B4	2765	2400	-	-	120
BFGE403C4	2765	2400	-	-	137
BFGE404B4	3555	3190	1580	1610	152
BFGE404C4	3555	3190	1580	1640	170
BFGE405B4	4345	3980	1580	1620	190
BFGE405C4	4345	3980	1580	1620	214
BFB					
BFBE402B7	1975	1610	-	-	76
BFBE402C7	1975	1610	-	-	85
BFBE403B7	2765	2400	-	-	109
BFBE403C7	2765	2400	-	-	122
BFBE404B7	3555	3190	1580	1610	137
BFBE404C7	3555	3190	1580	1640	150
BFBE405B7	4345	3980	1580	1620	171
BFBE405C7	4345	3980	1580	1620	189

We reserve the right to change our technical data without prior notice.

BFG/BFB

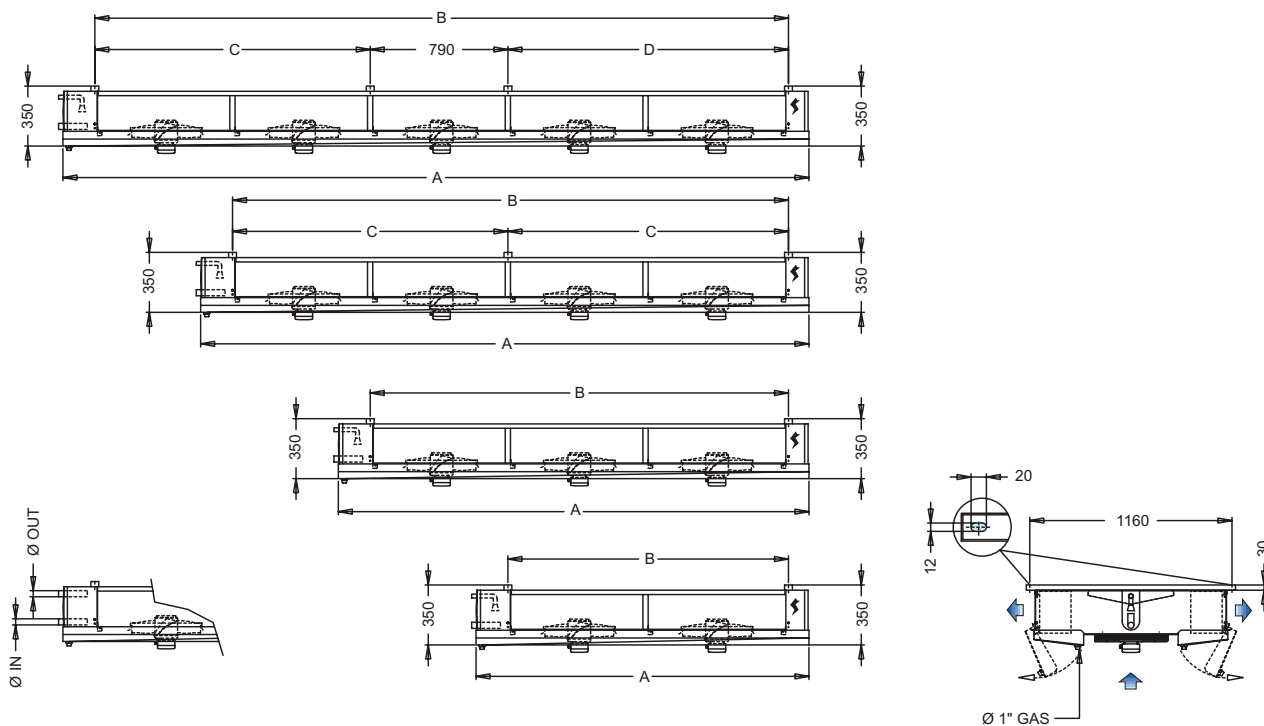

Model	Dimensions				Weight Kg
	mm A	mm B	mm C	mm D	
BFG/BFB TFG					
TFGE401A4	1120	820	-	-	38
TFGE401B4	1120	820	-	-	45
TFGE402A4	1910	1610	-	-	70
TFGE402B4	1910	1610	-	-	85
TFGE403A4	2700	2400	-	-	95
TFGE403B4	2700	2400	-	-	120
TFGE404B4	3490	3190	1580	1610	152
TFGE405B4	4280	3190	1580	1610	190

We reserve the right to change our technical data without prior notice.

TFG

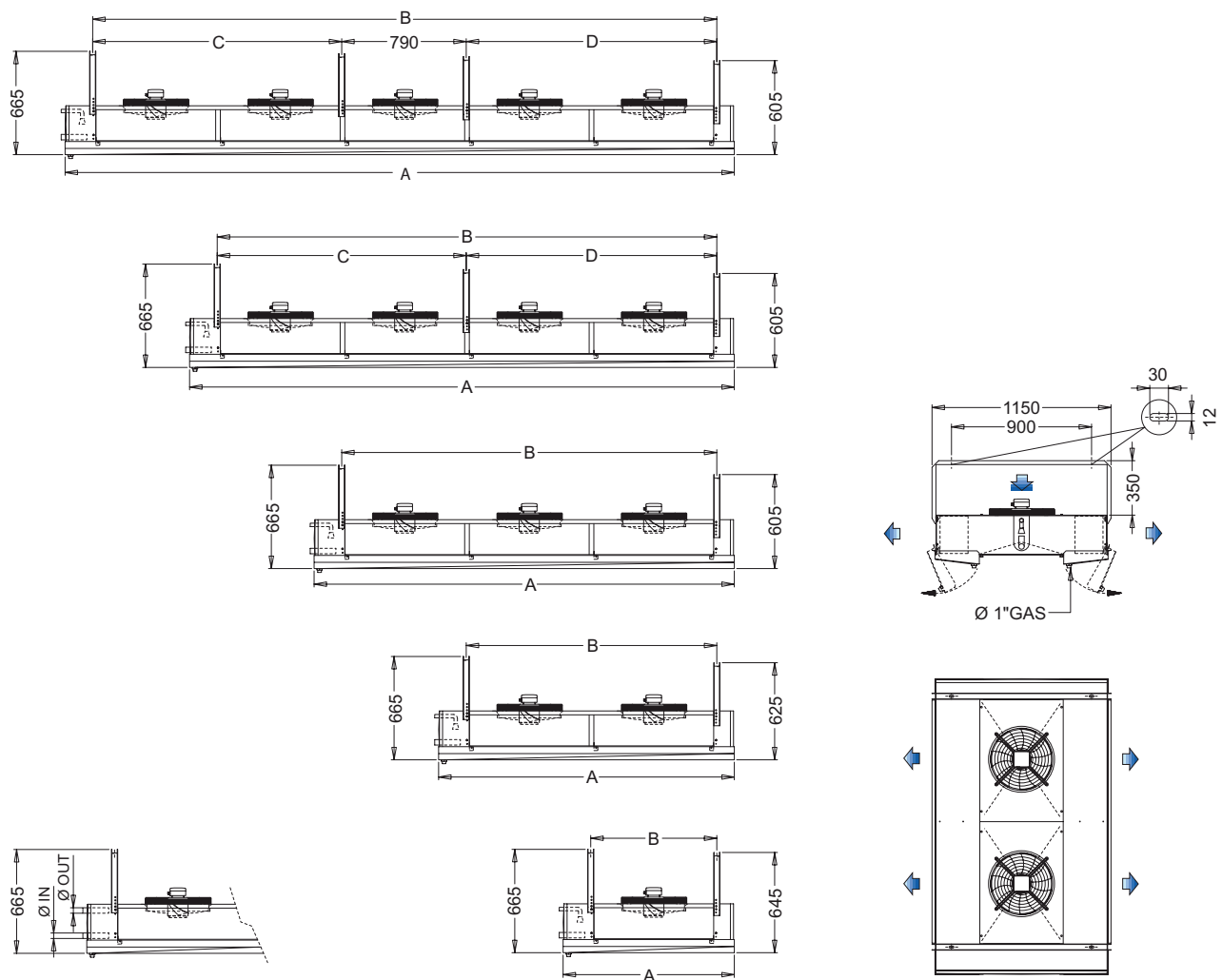

BFG/BFB,TFG

Options

Terminal Box

	See Electrical Data Page.	Model: ALL APPLICATIONS All Models
--	---------------------------	--

Fan Motor

	Different fan motors suitable for different installations 6-pole, 230V/1 Ph 4-pole, 400V/3 Ph 6-pole, 400V/3 Ph	Model: ALL APPLICATIONS All Models
---	--	--

Local safety switch wired

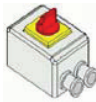
	See Electrical Data Page.	Model: ALL APPLICATIONS All Models
--	---------------------------	--

Reheating coil

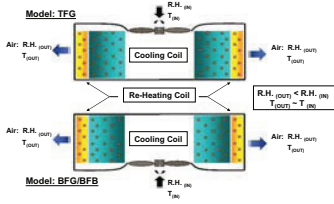
<p style="text-align: center;">Re heating coil for Dual Discharge</p> 	<p>Use:</p> <p>It is an additional coil used for dehumidifying or heating the air outlet of the one or two rows There are two systems:</p> <ul style="list-style-type: none"> • Using warm water with minimal flow rate provides a small air temperature rise. • Using electric heaters fixed into the finned tube coil. <p>Quick selection:</p> <ul style="list-style-type: none"> • Product available: TFG and BFG/BFB. • Permanent 2 row tube for reheating coil. • Coil sizes with reheating water: <ul style="list-style-type: none"> - A coil size + 2 rows (reheating coil). - B coil size + 2 rows (reheating coil). - In case C coil size: due to space limitations in the unit, the cooling coil will be B. 	Model: ALL APPLICATIONS All Models
--	--	--

Coil Treatment / Material

	<p>Pre-coated fins: Epoxy-coated, pre-painted aluminium fins.</p> <p>Cataphoresis treatment: An electrolytic process is achieved by submerging the coil in a paint bath, where it acts as a cathode and gets completely coated in an epoxy paint, which gives exceptional protection against corrosion. Recommended for alkaline or saline atmospheres.</p> <p>Stainless steel tubes with aluminium fins.</p> <p>Application use: More information on corrosion prevention can be found in the Miscellaneous section</p>	Model: ALL APPLICATIONS All Models
--	---	--

Cabinet made entirely of stainless steel

	<p>Casework component in stainless steel AISI 304. Application Use: More information on corrosion prevention can be found in the Miscellaneous section.</p>	<p>Model: ALL APPLICATIONS All Models</p>
--	--	---

Drip tray isolated

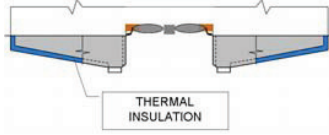

Construction: Sandwich manufactured with two aluminium shells and 12mm polyethylene insulation in between.
 Features: The insulation prevents water from condensing on the bottom of the drip-tray and reduces the transfer of the defrost heat into the cold room. It can be combined with Electric defrost or Hot Gas defrost.
 Applications: Room temperatures below -25°C and food processing rooms.

Model:
ALL APPLICATIONS
 All Models

BFG/BFB,TFG

Electrical Data

Junction box for motors

FG/BFB,TFG series

Function

Junction box complete with screw-on cover, cable glands and terminal strip.

General data

Material: Plastic

IP Protection Class: Min IP55

Colour: Grey RAL7035

Insulation class: II

Ambient Temp.: -25°C Max +50°C

Weight: 0,5 kg

Dimensions

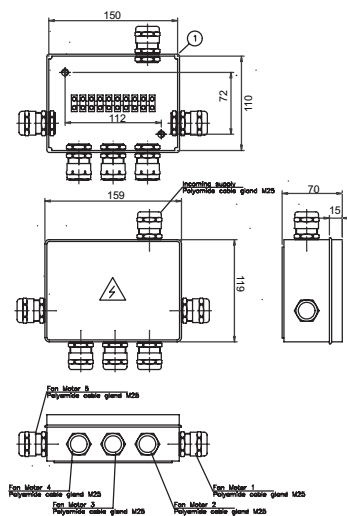

Electric wiring diagram

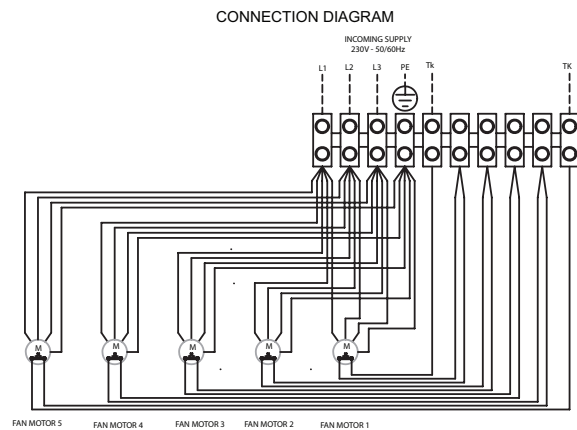

Junction box for "E" defrost

FG/BFB,TFG series

Function

Junction box complete with screw-on cover, cable glands and terminal strip.

General data

- Material: Plastic
- IP Protection Class: Min IP55
- Colour: Grey RAL7035
- Insulation class: II
- Ambient Temp.: -25°C Max +50°C
- Weight: 0,5 kg

Dimensions Electric wiring diagram

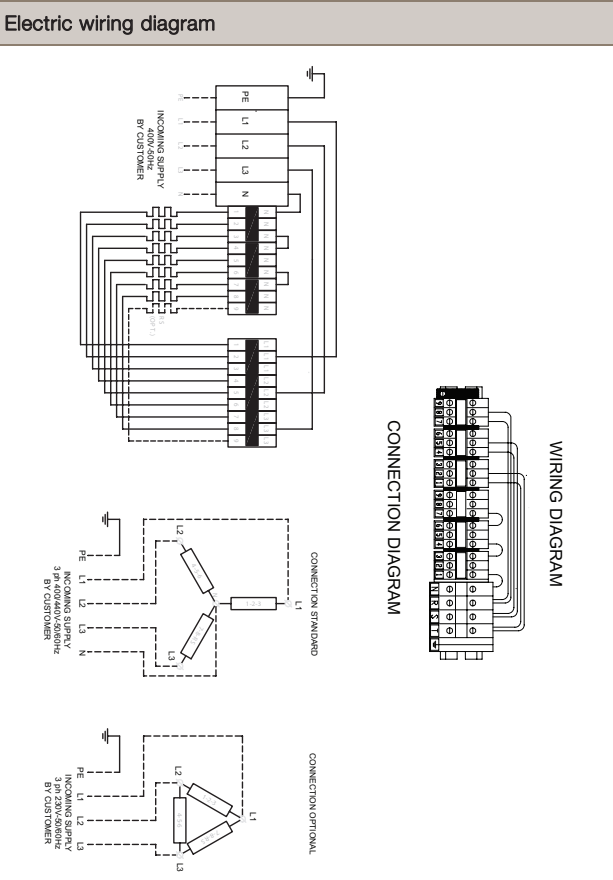
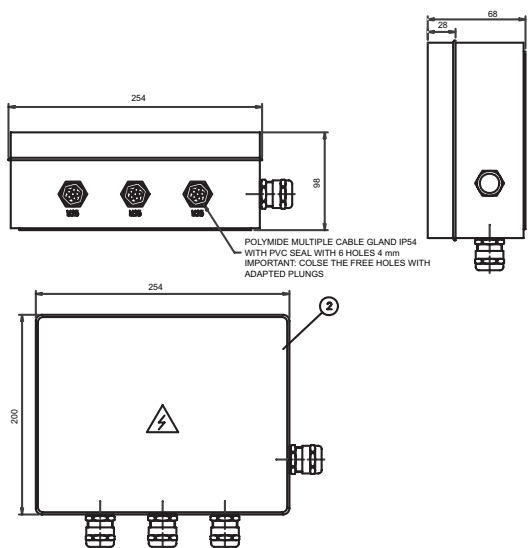

BFG/BFB,TFG

Electric Heater

ALL SERIES

Function

The elements are designed to operate in a refrigeration field with high moisture rate.

Special care is taken in selecting the power supply, cables and insulation materials.

General data

Model	ELECTRICAL DEFROST				ELECTRICAL ELEMENT DRAIN LINE (Optional)
	COIL		DRIP TRAY		
	N° heater	P(W)	N° heater	P(W)	P(W)
BFG/BFB					
BFGE402B4	4	4800	2	1600	70+70
BFGE402C4	6	7200	2	1600	70+70
BFGE403B4	4	6800	2	2400	70+70
BFGE403C4	6	10200	2	2400	70+70
BFGE404B4	4	8800	2	3200	70+70
BFGE404C4	6	13200	2	3200	70+70
BFGE405B4	4	10800	2	4400	70+70
BFGE405C4	6	16200	2	4400	70+70
BFBE402B7	4	4800	2	1600	70+70
BFBE402C7	6	7200	2	1600	70+70
BFBE403B7	4	6800	2	2400	70+70
BFBE403C7	6	10200	2	2400	70+70
BFBE404B7	4	8800	2	3200	70+70
BFBE404C7	6	13200	2	3200	70+70
BFBE405B7	4	10800	2	4400	70+70
BFBE405C7	6	16200	2	4400	70+70
TFG					
TFGE401A4	2	1000	2	1000	70+70
TFGE401B4	4	2000	2	1000	70+70
TFGE402A4	2	2400	2	1600	70+70
TFGE402B4	4	4800	2	1600	70+70
TFGE403A4	2	3400	2	2400	70+70
TFGE403B4	4	6800	2	2400	70+70
TFGE404B4	2	8800	2	3200	70+70
TFGE405B4	4	10800	2	4400	70+70

We reserve the right to change our technical data without prior notice.

BFG/BFB,TFG

Code description

Series	Room Temperature	Fin Spacing
G	Fruit and vegetables (from 0 to 10° C)	4 mm
B	Frozen food (from -18 to -25° C)	7 mm

1	2	3	4	5
BFG	E	S	40	3
				B

BFG	Green Line
BFB	Blue Line
TFG	Green Line

1) Application

E	Direct Expansion Evaporator
W	Brine Unit Cooler
A	Ammonia Pump Evaporator

2) Noise Level

S	4-pole fan motor
L	6-pole fan motor

3) Fan diameter : 40 (Ø 400mm)

4) Numbers of fans: from 1 to 5.

5) Coil Size: A, B or C

General Alfa Select Air Legend

Description 1		Description 2	
D	D fan cabling (three phase)	BSFT	Basic Switch Board + Speed Control Temp. + Signal
Y	Y fan cabling (three phase)	BI	Basic Switch Board + Frequency Converter (Inverter)
D/Y	D/Y fan cabling (three phase), single speed fan motor	BSI	Basic Switch Board + Frequency Converter (Inverter) + Signal
S	Single phase	C	Switch Board + Cooling fan
P	Packaged on a pallet	R	Switch Board + Resistor
CR	Packaged in a crate	F	Switch Board + Cooling fan + Resistor
BO	Packaged in a box	PT	Ammonia pump top
Feet	Feet-mounted	PB	Ammonia pump bottom
SW	Safety Switch	AL	Aluminium casing
CB	Terminal Box	SS	Stainless Steel casing
B	Basic Switch Board	AP	Pre-painted Aluminium casing
BS	Basic Switch Board + Signal	PL	Plastic casing
BP	Basic Switch Board + Step Control Pressure	E	Electrical defrost
BT	Basic Switch Board + Step Control Temperature	LE	Low Electrical defrost
BSP	Basic Switch Board + Step Control Pressure + Signal	A	Air Defrost
BST	Basic Switch Board + Step Control Temp. + Signal	HG	Hot Gas Defrost
BFP	Basic Switch Board + Speed Control Pressure	HG+E	Hot Gas Defrost + Electrical Defrost on drip tray
BFT	Basic Switch Board + Speed Control Temperature	W	Water Defrost
BSFP	Basic Switch Board + Speed Control Pres. + Signal	W+E	Water Defrost + Electrical Defrost on drip tray
AL	Aluminium fin	AL	Aluminium fin
CU	Copper fin	CU	Copper fin
PR	Pre-coated fin	PR	Pre-coated fin
SS	Stainless steel tube	SS	Stainless steel tube
TH	Thermoguard treatment	TH	Thermoguard treatment
CF	Cataphoresis treatment	CF	Cataphoresis treatment
SC	Sub-cooling circuit	SC	Sub-cooling circuit
kW	Spray water kit	kW	Spray water kit
FL	Flanges	FL	Flanges
FH	Fan ring heater	FH	Fan ring heater
IS	Insulated Drip Tray	IS	Insulated Drip Tray
RH	Reheating coil	RH	Reheating coil
SR	Air socket adapter ring	SR	Air socket adapter ring
CW	Air throw fan cowling	CW	Air throw fan cowling
ER	120° elbow reducer	ER	120° elbow reducer
HN	Hinged fan cowling	HN	Hinged fan cowling

Note: valid for the entire product range

BigTop

Product description

Applications

Double air flux series, designed for use in cold rooms housing fresh and frozen goods, ranging in volume from 300 to 2000m³. Unit designed for quick and simple maintenance with easy access to key inspection areas. This series is available as an evaporator (DX or pump, HFC, NH₃ and CO₂) and as a Brine unit cooler.

Standard design

Coil

Coil manufactured from corrugated aluminium fins and copper rippled tubes with a diameter of 12mm for a DX evaporator and smooth tubes with a 12mm diameter for Brine and 16mm tubes for NH₃ units and CO₂ units.

Casing

The casing is manufactured from pre-painted aluminium sheets (RAL 9010), which are protected by plastic film for extra protection during transit.

Benefits

- Low power consumption fan motor
- Low noise level
- Easy maintenance and access
- Eurovent certified

Options

- Pre-wired to main terminal box
- Motor fan 400V/3ph 50Hz, 4 and 6-pole
- Local safety switch wired
- Reheating coil
- Pre-coated fins
- Cataphoresis treatment
- Stainless steel tube
- Many fin spacing options
- Stainless steel casing
- Double insulated drip trays
- Carbon steel connection
- Electric defrost
- Water defrost



Fans

Three-phase motor 400V-50Hz, dual fan speed, protection class IP 54 according to DIN 40050. Integrated thermo contacts provide reliable protection against overload. The fans are suitable for operation in air temp. application between -40°C and +40°C.

For air temperature lower than +20°C, the full load current (FLC) can be calculated by using the correction factor table. The overload protectors should have a 20% margin to accommodate fan motor supplier variations.

T [°C]	20	10	0	-10	-15	-20	-25	-30
Fc	1	1,04	1,08	1,12	1,14	1,16	1,18	1,2

Model	Capacity [SC2]	Capacity [SC3]	Airflow	Air Throw	P	Surface	Tube Volume	Noise	El. Power	Voltage	Current	Fan D.	No. fans	Connection	
	kW	kW	m³/h	m	mm	m²	dm³	dB(A)	W	V	A	mm		Inlet	Outlet
5 mm fin spacing															
ITRE562B5	26,05	19,99	20770	2x25	5	144,9	18,7	70	1700	400(D)	3,4	560	2	28	42
ITRE562C5	30,97	23,56	19658	2x24	5	193,2	24,9	70	1700	400(D)	3,4	560	2	35	42
ITRE563B5	38,92	29,43	31155	2x30	5	217,4	28,1	72	2550	400(D)	5,1	560	3	35	54
ITRE563C5	46,58	35,55	29487	2x29	5	289,9	37,4	72	2550	400(D)	5,1	560	3	35	54
ITRE564B5	52,24	40,24	41580	2x35	5	289,9	37,4	73	3400	400(D)	6,8	560	4	35	54
ITRE564C5	62,61	48,21	39316	2x33	5	386,5	49,9	73	3400	400(D)	6,8	560	4	35	60
7 mm fin spacing															
ITBE562B7	21,81	16,88	21394	2x26	7	105,4	18,7	70	1700	400(D)	3,4	560	2	28	42
ITBE562C7	26,69	20,47	20410	2x24	7	140,6	24,9	70	1700	400(D)	3,4	560	2	35	42
ITBE563B7	32,77	25,06	32092	2x31	7	158,2	28,1	72	2550	400(D)	5,1	560	3	35	54
ITBE563C7	40,08	30,82	30614	2x30	7	210,9	37,4	72	2550	400(D)	5,1	560	3	35	54
ITBE564B7	44	33,81	42789	2x36	7	210,9	37,4	73	3400	400(D)	6,8	560	4	35	54
ITBE564C7	53,39	40,5	40819	2x35	7	281,2	49,9	73	3400	400(D)	6,8	560	4	35	60

*Nominal capacity according to ENV328 and Eurovent regulations (refrigerant R404A, $\Delta T1 = T_{Inair} - T_{ev}$). Use external equalised thermostatic expansion valve.

Model	Capacity	Fluid Flow	Fluid Pressure Drop	Circuit	Air Flow	Air Throw	Surface	Tube volume	Motor data (3ph 400V-50Hz)	Fans	Defrost				Noise	Connections		Weight
											Elec-tric	Elec.+ Hot Gas	Water			mm		
	kW	m³/h	bar	m³/h	m	m²	dm³	Δ	n° x Ømm	kW	kW	l/h	kPa	dB(A)	(5 m)	inlet	outlet	Kg
5 mm fin spacing																		
ITRW562B5	26,4	6,172	44,3	B	18044	2X25	140,5	35	P = 1000W I _n = 1,8 A n = 1220 min ⁻¹	2 x 560	14,4	1,8	5120	10	70	1"1/2	1"1/2	170
ITRW562C5	31,24	7,293	42,82	B	16342	2X24	187,3	46		2 x 560	17,6	1,8	6400	15	70	1"1/2	1"1/2	197
ITRW563B5	39,15	9,14	41,4	D	27073	2X30	210,8	51		3 x 560	22,2	3	7680	15	72	2"	2"	221
ITRW563C5	42,47	9,925	28,83	A	24595	2X29	281	68		3 x 560	27	3	9600	20	72	2"	2"	250
ITRW564B5	51,95	12,13	40,11	D	36107	2X35	281	69		4 x 560	27,8	3,7	10240	20	73	2"1/2	2"1/2	290
ITRW564C5	61,74	14,42	39,2	E	32697	2X33	374,7	90		4 x 560	34,7	3,7	12840	25	73	2"1/2	2"1/2	328
7 mm fin spacing																		
ITBW562B7	23,65	5,529	36,49	B	18934	2X25	102,9	35	P = 1000W I _n = 1,8 A n = 1220 min ⁻¹	2 x 560	14,4	1,8	5120	10	70	1"1/2	1"1/2	161
ITBW562C7	28,77	6,729	37,16	B	17301	2X24	137,1	46		2 x 560	17,6	1,8	6400	15	70	1"1/2	1"1/2	205
ITBW563B7	35,03	8,179	34,04	C	28409	2X30	154,3	51		3 x 560	22,2	3	7680	15	72	2"	2"	183
ITBW563C7	46,05	10,761	48,16	C	25900	2X29	205,7	68		3 x 560	27	3	9600	20	72	2"	2"	230
ITBW564B7	46,44	10,847	32,94	D	37885	2X35	205,7	69		4 x 560	27,8	3,7	10240	20	73	2"1/2	2"1/2	205
ITBW564C7	56,61	13,221	33,64	E	34620	2X33	274,3	90		4 x 560	34,7	3,7	12840	25	73	2"1/2	2"1/2	255

*Nominal capacity according to EN 1048 and Eurovent regulations (refrigerant R404A, Air TIN = +2°C / R.H. = 85%, 30% Et. Gly. , Temp = -8 / -4°C). Use external equalised thermostatic expansion valve.

Model	Capacity* SC2	Capacity* SC3	Airflow	Air Throw	Surface	Tube volume	Defrost				Fan motors	Motor data	Noise	Connections		Weight
	kW	kW	m³/h	m	m²	dm³	Elec-tric	Elec.+ Hot gas	Water		n° x Ømm			dB(A)	mm	
	$\Delta T1 = 8K, T_{ev} = -8°C$	$\Delta T1 = 7K, T_{ev} = -25°C$					kW	kW	l/h	kPa		Δ	(5 m)		inlet	outlet
Fin Spacing 5mm																
ITRA562B5	38,1	28,7	18309	2x25	140,7	40	14,4	1,8	5120	10	2 x 560	P = 1000W I _n = 1,8 A n = 1220 min ⁻¹	70	33	33	170
ITRA562C5	41,7	31,4	17067	2x24	175,9	50	17,6	1,8	6400	15	2 x 560		70	33	33	197
ITRA563B5	55,5	40,2	27454	2x30	211,1	59	22,2	3	7680	15	3 x 560		72	42	42	221
ITRA563C5	61,3	44,9	25593	2x29	263,9	74	27	3	9600	20	3 x 560		72	48	48	250
ITRA564B5	69,0	47,7	36600	2x35	281,5	78	27,8	3,7	10240	20	4 x 560		73	48	48	290
ITRA564C5	77,2	54,2	34119	2x33	351,8	98	34,7	3,7	12840	25	4 x 560		73	60	60	328
Fin Spacing 7mm																
ITBA562B7	33,0	24,8	19280	2X26	103,5	40	14,4	1,8	5120	10	2 x 560	P = 1000W I _n = 1,8 A n = 1220 min ⁻¹	70	33	33	161
ITBA562C7	37,1	27,8	18107	2X24	129,4	50	17,6	1,8	6400	15	2 x 560		70	33	33	183
ITBA563B7	48,8	35,8	28911	2X31	155,3	59	22,2	3	7680	15	3 x 560		72	42	42	205
ITBA563C7	55,2	40,7	27151	2X30	194,2	74	27	3	9600	20	3 x 560		72	48	48	230
ITBA564B7	61,8	43,5	38542	2X36	207,1	78	27,8	3,7	10240	20	4 x 560		73	48	48	268
ITBA564C7	70,4	50,1	36196	2X35	258,9	98	34,7	3,7	12840	25	4 x 560		73	60	60	301



BigTop

Drawings

Model	Dimensions			Weight
	mm	mm	mm	
	A	B	C	Kg
ITRE/W562B5	2420	2030	-	170
ITRE/W562C5	2420	2030	-	197
ITRE/W563B5	3420	3030	-	221
ITRE/W563C5	3420	3030	-	250
ITRE/W564B5	4420	4030	2000	290
ITRE/W564C5	4420	4030	2000	328
ITBE/W562B7	2420	2030	-	161
ITBE/W562C7	2420	2030	-	205
ITBE/W563B7	3420	3030	-	183
ITBE/W563C7	3420	3030	-	230
ITBE/W564B7	4420	4030	2000	205
ITBE/W564C7	4420	4030	2000	255
ITRA562B5	2420	555	1700	170
ITRA562C5	2420	555	1700	197
ITRA563B5	3420	555	1700	221
ITRA563C5	3420	555	1700	250
ITRA564B5	4420	555	1700	290
ITRA564C5	4420	555	1700	328
ITBA562B7	2420	555	1700	161
ITBA562C7	2420	555	1700	183
ITBA563B7	3420	555	1700	205
ITBA563C7	3420	555	1700	230
ITBA564B7	4420	555	1700	268
ITBA564C7	4420	555	1700	301

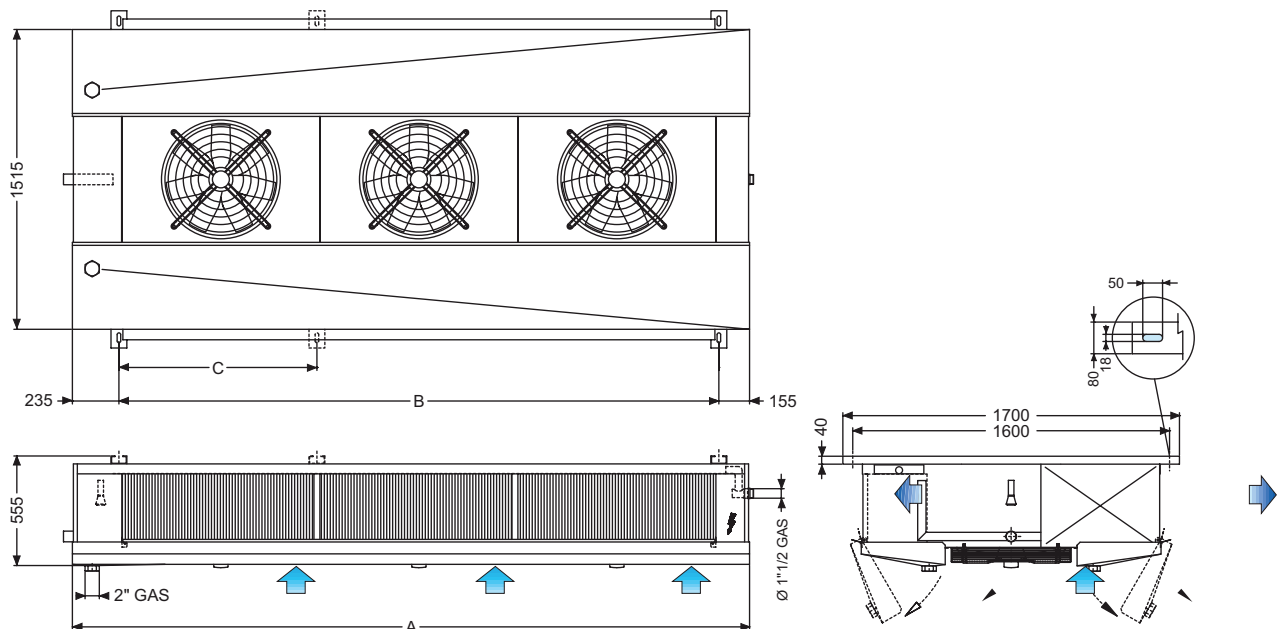
We reserve the right to change our technical data without prior notice.

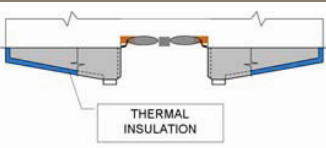

<h1>BigTop</h1>		
<h2>Options</h2>		
Terminal Box		
	See Electrical Data Page.	Model: ALL APPLICATIONS All Models
Fan Motor		
	Different fan motors suitable for different installations 6-pole, 230V/1 Ph 4-pole, 400V/3 Ph 6-pole, 400V/3 Ph	Model: ALL APPLICATIONS All Models
Local safety switch wired		
	See Electrical Data Page.	Model: ALL APPLICATIONS All Models
Coil Treatment / Material		
	<p>Pre-coated fins: Epoxy-coated, pre-painted aluminium fins.</p> <p>Cataphoresis treatment: An electrolytic process is achieved by submerging the coil in a paint bath, where it acts as a cathode and gets completely coated in an epoxy paint, which gives exceptional protection against corrosion. Recommended for alkaline or saline atmospheres.</p> <p>Stainless steel tubes with aluminium fins.</p> <p>Application use: More information on corrosion prevention can be found in the Miscellaneous section</p>	Model: ALL APPLICATIONS All Models
Special fin spacing		
	Different fin spacings are available for the ITR and ITB series. Airflow and air throw are strongly influenced by spacing variations.	Model: ALL APPLICATIONS All Models
Cabinet made entirely of stainless steel		
	Casework component in stainless steel AISI 304. Application Use: More information on corrosion prevention can be found in the Miscellaneous section.	Model: ALL APPLICATIONS All Models

Double drip tray isolated		
 <p style="text-align: center; margin-top: 5px;">THERMAL INSULATION</p>	<p>Construction: Sandwich manufactured with two aluminium shells and 12mm polyethylene insulation in between.</p> <p>Features: The insulation prevents water from condensing on the bottom of the drip-tray and reduces the transfer of the defrost heat into the cold room. It can be combined with Electrical or Hot Gas defrost.</p> <p>Applications: Room temperatures below -25°C and food processing rooms.</p>	<p>Model: ALL APPLICATIONS All Models</p>
Carbon Steel Connection		
	<p>End Fe connection for stainless steel headers; optional in situation where it's not easy to weld inox piping.</p>	<p>Model: ALL APPLICATIONS All Models</p>

BigTop

Electrical Data

Junction box for motors

ITR/ITB series

Function

Metallic junction box complete with cable glands and terminal strip.

General data

Protection class IP55

Operating temperature: min -25°C max +50°C

Internal dimensions (HxWxD): 250x200x105mm

Wall mounting type

N° 5 brass cable glands metric type M25 (IP66);

N° 1 brass cable glands metric type M32 (IP66);

N° 6 discs anti-powder.

With terminal strip

Switch: 4x16A.

With terminal strip

Material/Colour: sheet of steel / grey RAL7032

Dimensions

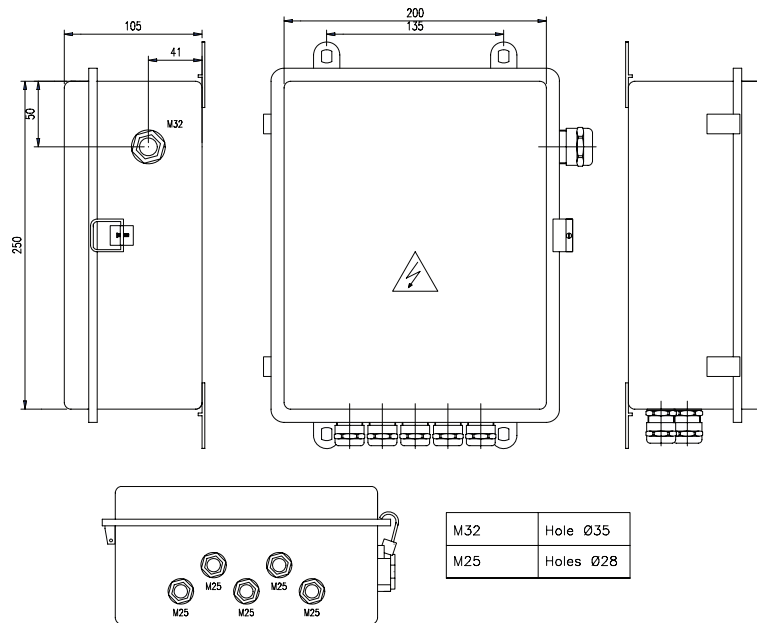

Electric wiring diagram

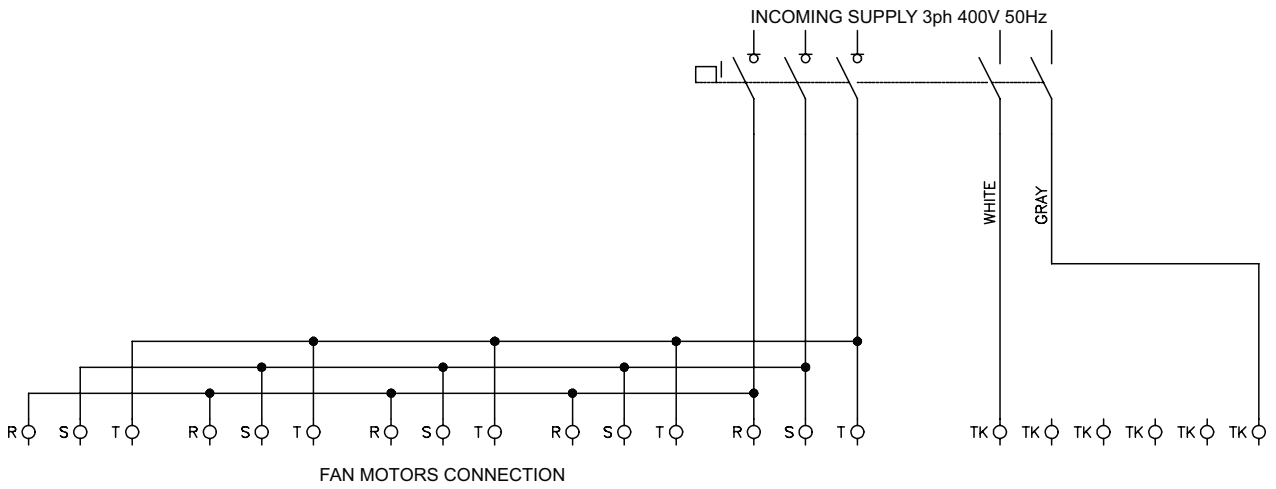

CONNECTION DIAGRAM

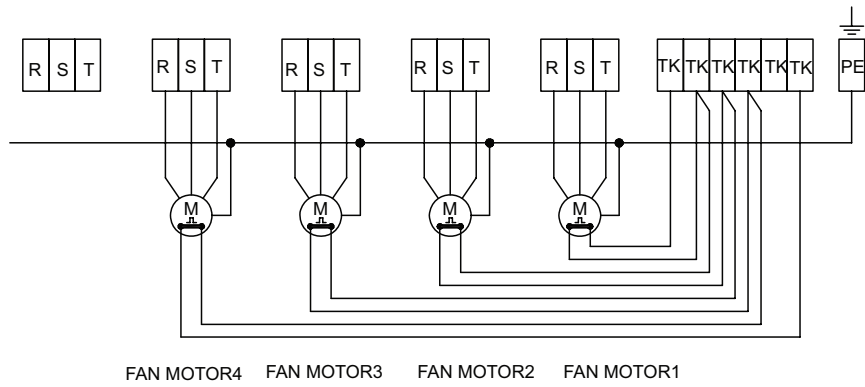

Junction box for "E" defrost

ITR/ITB series
Function

Junction box complete with screw-on cover, cable glands and terminal strip.

General data

Protection class IP56
 Operating temperature: min -25°C max +50°C
 Internal dimensions (HxWxD): 80x120x50mm
 Fixing holes (HxW): 42x82mm max. 8mm
 max. diameter of holes: 29mm
 lockable screws made of inox steel
 N° 1 plastic cable glands metric type M20 (IP67);
 N° 3 plastic multiple cable glands, metric type M20 (IP54); PVC seal with 4 holes Ø3mm
 N° 4 discs anti-powder.
 With terminal strip
 Material/Colour: GW plast 75 / grey RAL7035
 Shock-resistance: IK 08
 Fire-resistance: thermal & pressure test with sphere at 70°C , glow wire test 650°C
 Material according to norms IEC 60670 / EN50102 / CEI 23-48 ;

Dimensions

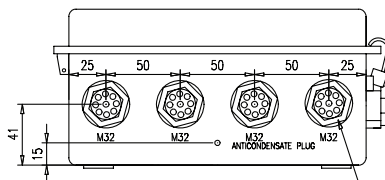
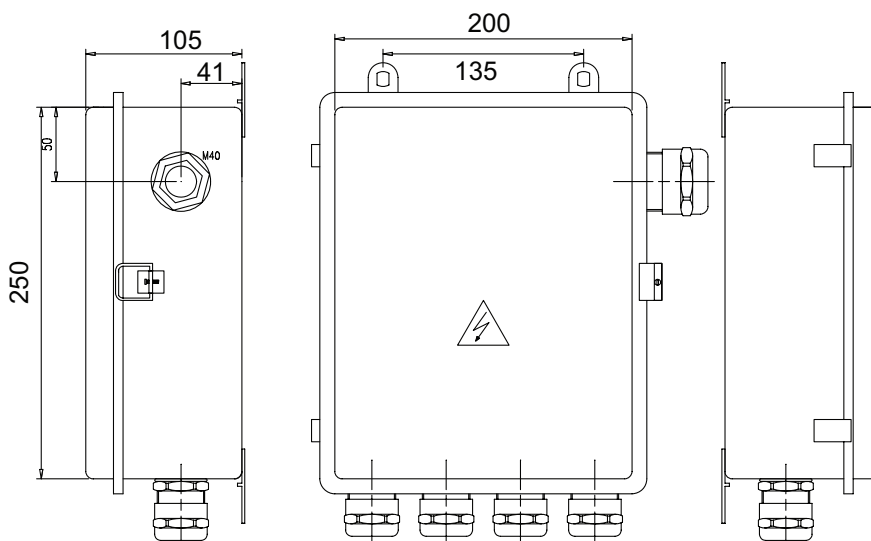

M32	Hole Ø35
M25	Holes Ø28
Anticondensate plug	Hole Ø4,25

BRASS MULTIPLE CABLE GLAND IP54
 WITH PVC SEAL WITH 9 HOLES Ø4mm
 IMPORTANT: CLOSE THE FREE HOLES WITH ADAPTED PLUGS

Electric wiring diagram

INTERNAL VIEW

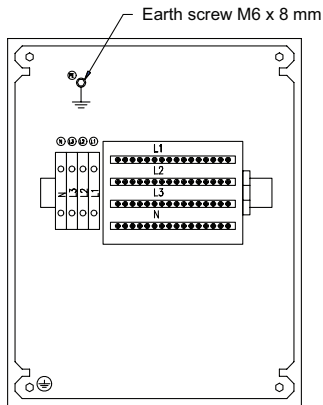

INCOMING SUPPLY
3Ph 400V-50Hz

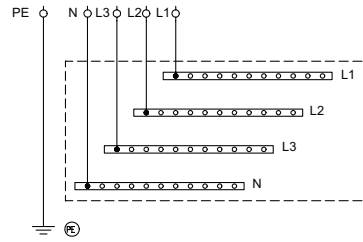

CONNECTION DIAGRAM

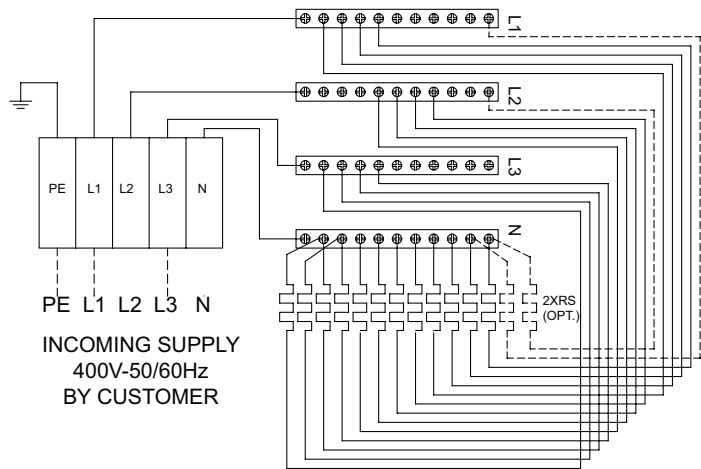

CONNECTION STANDARD

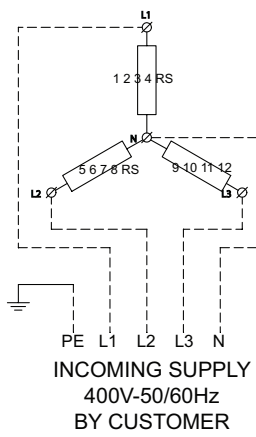

CONNECTION OPTIONAL

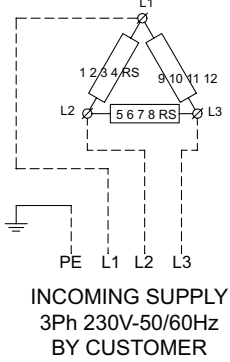

Big Top

Electric Heater

ALL SERIES

Function

The elements are designed to operate in a refrigeration field with high moisture rate.

Special care is taken in selecting the power supply, cables and insulation materials.

General data

Model	ELECTRICAL DEFROST					ELECTRICAL ELEMENT DRAIN LINE (Optional) P(W)
	COIL		DRIP TRAY		TOTAL	
	N° heater	P(W)	N° heater	P(W)	P(W)	
ITRE562B5	8	12560	2	3140	15700	100+100
ITRE562C5	10	15700	2	3140	18840	100+100
ITRE563B5	8	19200	2	4800	24000	100+100
ITRE563C5	10	24000	2	4800	28800	100+100
ITRE564B5	8	24800	2	6200	31000	100+100
ITRE564C5	10	31000	2	6200	37200	100+100
ITBE562B7	8	12560	2	3140	15700	100+100
ITBE562C7	10	15700	2	3140	18840	100+100
ITBE563B7	8	19200	2	4800	24000	100+100
ITBE563C7	10	24000	2	4800	28800	100+100
ITBE564B7	8	24800	2	6200	31000	100+100
ITBE564C7	10	31000	2	6200	37200	100+100

We reserve the right to change our technical data without prior notice.

BigTop

Code description

Series	Room Temperature	Fin Spacing
R	Fruit, vegetables and meat (from 0 to 10°C)	5 mm
B	Frozen food (from -18 to -25° C)	7 mm

1	2	3	4	5	6		
ITR	E	S	56	3	B	5	E

ITR	Red Line
ITB	Blue Line

1) Application

E	Direct Expansion Evaporator
W	Brine Unit Cooler
A	Ammonia Pump

2) Noise Level

S	4-pole fan motor
L	6-pole fan motor

3) Fan diameter : 56 (Ø 560 mm)

4) Numbers of fans: from 2 to 4.

5) Coil Size: B or C

6) Fin Spacing

5	R Series: 5mm
7	B Series: 7mm

7) Defrost

A	Air
E	Electric
W	Water Defrost

General Alfa Select Air Legend

Description 1		Description 2	
D	D fan cabling (three phase)	BSFT	Basic Switch Board + Speed Control Temp. + Signal
Y	Y fan cabling (three phase)	BI	Basic Switch Board + Frequency Converter (Inverter)
D/Y	D/Y fan cabling (three phase), single speed fan motor	BSI	Basic Switch Board + Frequency Converter (Inverter) + Signal
S	Single phase	C	Switch Board + Cooling fan
P	Packaged on a pallet	R	Switch Board + Resistor
CR	Packaged in a crate	F	Switch Board + Cooling fan + Resistor
BO	Packaged in a box	PT	Ammonia pump top
Feet	Feet-mounted	PB	Ammonia pump bottom
SW	Safety Switch	AL	Aluminium casing
CB	Terminal Box	SS	Stainless Steel casing
B	Basic Switch Board	AP	Pre-painted Aluminium casing
BS	Basic Switch Board + Signal	PL	Plastic casing
BP	Basic Switch Board + Step Control Pressure	E	Electrical defrost
BT	Basic Switch Board + Step Control Temperature	LE	Low Electrical defrost
BSP	Basic Switch Board + Step Control Pressure + Signal	A	Air Defrost
BST	Basic Switch Board + Step Control Temp. + Signal	HG	Hot Gas Defrost
BFP	Basic Switch Board + Speed Control Pressure	HG+E	Hot Gas Defrost + Electrical Defrost on drip tray
BFT	Basic Switch Board + Speed Control Temperature	W	Water Defrost
BSFP	Basic Switch Board + Speed Control Pres. + Signal	W+E	Water Defrost + Electrical Defrost on drip tray
AL	Aluminium fin	CU	Copper fin
PR	Pre-coated fin	SS	Stainless steel tube
TH	Thermoguard treatment	CF	Cataphoresis treatment
SC	Sub-cooling circuit	KW	Spray water kit
FL	Flanges	FH	Fan ring heater
IS	Insulated Drip Tray	RH	Reheating coil
SR	Air socket adapter ring	CW	Air throw fan cowling
ER	120° elbow reducer	HN	Hinged fan cowling

Note: valid for the entire product range

Blast Freezers

General Content

General Features

Most of our Blast Freezers are available in the following versions:

- Direct expansion Freon evaporator
- Pump ammonia evaporator

Freezing method

Blast freezing (convection).

The fans blow the air through the coil.

Cold air is circulated around the product at high speed. The air reduces heat in the product and diverts it to an air cooler before it is re-circulated.

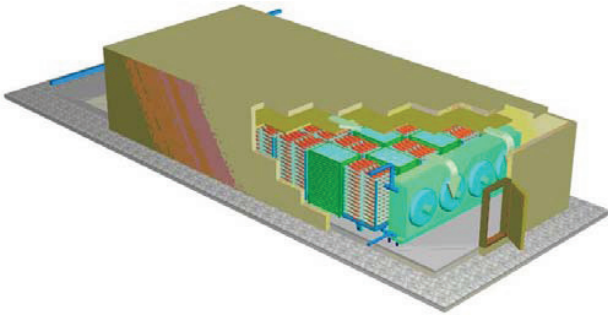

Application field

- Fast-Freezing in the Meat, Poultry and Fish industry
- Chilling tunnels with trolleys in the food sector: Bakery
- Deep Freezing Tunnels for ice cream production.

Guideline for freezing data of different products being frozen in the tunnel.

Product type	Product thickness	Entering/final temperature (°C)	Freezing Time (hrs)	Tunnel air temperature (°C)	Air blast velocity (m/s)
Beef	28	+30/-8	18/20	-35/+40	3 to 6
Poultry	8 to 18	+5/-18	2 to 7	-35	3 to 6
Whole fish	6 to 8	+10/-18	+10 to 6	-37	3 to 4
Fish fillets	6	+10/-18	4 to 6	-34	3 to 4

Air circulation

In a well designed and correctly operated air blast freezer, the air-speed over the food should be about the same throughout the freezer, therefore ensuring uniform freezing of the product. It is very important that the tunnel is designed so that resistance to the airflow created by the products to be frozen is spread evenly over the whole cross-section of the tunnel. The spaces between the trays should all be the same and the gap above, below and at the sides of the truck should be as small as possible; otherwise the lowest resistance and freezing will not be efficient.

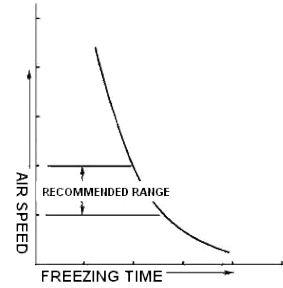

VARIAION OF FREEZING TIME WITH AIR SPEED

Air has a low heat capacity, and still air is a poor conductor of heat so a fairly high air speed is necessary. However, high air speeds mean powerful fans and these generate heat, which has to be removed by the refrigeration machinery. Consequently, there is little to be gained by using a very high air speed, and a speed range of 3 to 6m/second has been found to be most suitable for economic freezing.

Defrost

All our Blast Freezers are available with three different defrost systems:

E = Electric defrost (coil and drip tray).

HG = Hot Gas defrost (coil and drip tray).

HG+E = Hot Gas defrost in the coil + Electric in the drip tray.

W = Water cleaning (recommended for a deep cleaning of the coil) after the freezing cycle period.

Fin Spacing

In our experience, fin spacing for freezing tunnels should relate to the type of products being stored and the temperature conditions specific to that tunnel.

Fin spacing is influenced by:

- temperature of the goods on entry.
- type of packaging

Product	Entry Temperature (°C)	Fin Spacing (mm)
Packaging	≤ +4	min. 9
Unpackaged	≥ +15	min. 12

Available Pressure Difference

For platform rack trucks and other tunnel freezers: the arising pressure drags have to be specified by the operator.



Guide value for external pressure

- Alfa Blast 150 Pa: This unit can be used for shock cooling processes where the goods (typically meat) have to be cooled quickly but not too deeply. To ensure that the air can reach the product on all sides, fans with an external pressure drop are needed.
- Alfa Blast 80 Pa: A Freezer cooler can achieve similar results, but only if it supplies a minimum external pressure of 60-80 Pa, because lower values will not guarantee a proper freezing process. To achieve high pressure, a powerful fan motor has been designed for Alfa-Blast 80Pa.

Test and cleaning

The coils are cleaned and dehydrated in order to remove any traces of oil. Each heat exchanger undergoes a pressure and leak test with dry air at 30 bar, before being supplied with a nitrogen pre-charge.



AlfaBlast

Product description

Applications

AlfaBlast is a unit cooler with horizontal airflow. It is ideal for shock-freeze applications in confined spaces, and offers efficient capacity to industries such as meat, poultry, fish, baked goods, dairy, ice cream, ready-meals, and in all sectors where fast freezing of food is necessary.

Standard design

Coil

Coil manufactured from aluminium fins and copper rippled tubes for DX and stainless steel tubes for NH₃ units. Available fin spacing: 7, 10 or 12 mm. The fans blow the air through the coil.

Casing

It is manufactured from galvanized steel as standard, but can be made from stainless steel or aluminium as an optional extra. The drip tray is made from aluminium as standard and the lateral covers are also included.

Benefits

AlfaBlast is designed for applications with R404A, R507A, NH₃ and CO₂. The refrigerant cost is lower than comparable products on the market, which will have a positive effect both on your budget and the environment. To further support your budget targets, AlfaBlast offers low electricity consumption and smart solutions for easy installation and maintenance.

Options

- Casing in stainless steel or aluminium
- Special fans for high static pressure
- Different coil protection (cataphoresis, thermoguard, pre-coated fins)
- Different defrost systems (water, electric, hot gas)



Fans

Diameter: 500 or 630mm

Motor fan type: 3-phase 400V 50/60Hz

Air static pressure: 50 or 100 Pa (150 Pa on request)

The fans are suitable for operation in air temp. application between -40°C and +40°C.

For air temperature lower than +20°C, the full load current (FLC) can be calculated by using the correction factor table. The overload protectors should have a 20% margin to accommodate fan motor supplier variations.

T [°C]	20	10	0	-10	-15	-20	-25	-30
Fc	1	1,04	1,08	1,12	1,14	1,16	1,18	1,2

Model	Capacity		Air Flow	Static Pressure	Surface	Tube volume	Motor data (3/400V-50Hz)	Electric defrost Power			Fans	Noise	Conn. out	Drain connection	Weight
	SC3	SC4						Coil Power	Drain Pan Power	Power tot					
	[kW]	[kW]	m ²	dm ³	Δ	[kW]	[kW]				[kW]	dB(A) 5m	Outlet		
7 mm fin spacing															
ABE501A7	13,23	10,44	13613	80	81,28	15,21	P= 780W I _n = 1.35 n= 1340min-1	7,4	1,5	8,9	2x500	66	48	2"	225
ABE501B7	15,97	12,67	12849	80	108,37	20,3		10,4	1,5	11,8	2x500	66	48	2"	230
ABE501C7	18	14,41	12181	80	135,47	25,36		13,3	1,5	14,8	2x500	66	48	2"	235
ABE502A7	27,33	21,71	27489	80	167,91	31,43		14,8	3,0	17,8	4x500	69	60	2"	450
ABE502B7	32,94	26,2	26005	80	223,88	41,91		20,7	3,0	23,7	4x500	69	60	2"	460
ABE502C7	37,11	29,75	24700	80	279,85	52,38		26,6	3,0	29,6	4x500	69	60	2"	470
ABE503A7	41,67	33,18	41360	80	254,54	47,65		22,0	4,4	26,4	6x500	71	76	2"	675
ABE503B7	50,12	40,1	39157	80	339,38	63,5		30,8	4,4	35,2	6x500	71	60x2	2"	690
ABE503C7	56,43	45,44	37213	80	424,23	79,4		39,6	4,4	44,0	6x500	71	60x2	2"	702
ABE504A7	54,12	42,62	55229	80	341,16	63,7		29,6	5,9	35,5	8x500	72	76	2"	900
ABE504B7	65,5	51,88	52306	80	454,88	85,15	41,4	5,9	47,4	8x500	72	60x2	2"	918	
ABE504C7	74,24	59,12	49725	80	568,60	106,4	53,3	5,9	59,2	8x500	72	60x2	2"	936	
ABE631A7	24,36	19,25	25878	100	146,87	27,49	P= 1800W I _n = 3.6 n= 1260min-1	12,6	1,8	14,4	2x630	80	60	2"	375
ABE631B7	29,62	23,53	24619	100	195,83	36,66		16,2	1,8	18,0	2x630	80	60	2"	382
ABE631C7	33,76	26,83	23508	100	244,79	45,82		19,8	1,8	21,6	2x630	80	60	2"	390
ABE632A7	49,96	39,52	52078	100	300,88	56,32		27,4	3,9	31,4	4x630	83	76	2"	750
ABE632B7	60,68	48,26	49617	100	401,17	75,1		35,3	3,9	39,2	4x630	83	60x2	2"	765
ABE632C7	69,07	54,97	47436	100	501,47	93,87		43,1	3,9	47,0	4x630	83	60x2	2"	780
ABE633A7	74,03	58,23	78273	100	454,88	85,15		41,4	5,9	47,4	6x630	85	60x2	2"	1125
ABE633B7	90,01	71,12	74609	100	606,51	113,5		53,3	5,9	59,2	6x630	85	76x2	2"	1148
ABE633C7	102,83	81,74	71359	100	758,14	141,9		65,1	5,9	71,0	6x630	85	76x2	2"	1170
10 mm fin spacing															
ABE501A10	10,97	8,73	14057	80	58,58	15,21	P= 780W I _n = 1.35 n= 1340min-1	7,4	1,5	8,9	2x500	66	48	2"	218
ABE501B10	13,5	10,78	13372	80	78,10	20,3		10,4	1,5	11,8	2x500	66	48	2"	223
ABE501C10	15,57	12,48	12760	80	97,63	25,36		13,3	1,5	14,8	2x500	66	48	2"	228
ABE502A10	22,67	18,04	28346	80	121,01	31,43		14,8	3,0	17,8	4x500	69	60	2"	437
ABE502B10	27,82	22,26	27023	80	161,35	41,91		20,7	3,0	23,7	4x500	69	60	2"	446
ABE502C10	32,06	25,73	25832	80	201,68	52,38		26,6	3,0	29,6	4x500	69	60	2"	456
ABE503A10	34,27	27,45	42629	80	183,44	47,65		22,0	4,4	26,4	6x500	71	76	2"	655
ABE503B10	42,11	33,82	40668	80	244,59	63,5		30,8	4,4	35,2	6x500	71	60x2	2"	669
ABE503C10	48,5	39,06	38898	80	305,73	79,4		39,6	4,4	44,0	6x500	71	60x2	2"	681
ABE504A10	45,5	36,06	56911	80	245,87	63,7		29,6	5,9	35,5	8x500	72	76	2"	873
ABE504B10	56,08	44,43	54312	80	327,83	85,15	41,4	5,9	47,4	8x500	72	60x2	2"	890	
ABE504C10	64,74	51,51	51964	80	409,79	106,4	53,3	5,9	59,2	8x500	72	60x2	2"	908	
ABE631A10	20,3	16,06	26607	100	105,85	27,49	P= 1800W I _n = 3.6 n= 1260min-1	12,6	1,8	14,4	2x630	80	60	2"	364
ABE631B10	25,11	19,95	25482	100	141,13	36,66		16,2	1,8	18,0	2x630	80	60	2"	371
ABE631C10	29,05	23,23	24472	100	176,42	45,82		19,8	1,8	21,6	2x630	80	60	2"	378
ABE632A10	41,55	32,93	53497	100	216,84	56,32		27,4	3,9	31,4	4x630	83	76	2"	728
ABE632B10	51,37	40,88	51306	100	289,12	75,1		35,3	3,9	39,2	4x630	83	60x2	2"	742
ABE632C10	59,39	47,56	49328	100	361,40	93,87		43,1	3,9	47,0	4x630	83	60x2	2"	757
ABE633A10	62,16	49,2	80383	100	327,83	85,15		41,4	5,9	47,4	6x630	85	60x2	2"	1091
ABE633B10	76,93	60,82	77124	100	437,10	113,5		53,3	5,9	59,2	6x630	85	76x2	2"	1114
ABE633C10	89,33	70,96	74179	100	546,38	141,9		65,1	5,9	71,0	6x630	85	76x2	2"	1135

*Nominal capacity according to ENV328 and Eurovent regulations (refrigerant R404A, ΔT1 = T_{Nair} - T_{ev}). Use external equalised thermostatic expansion valve.

Model	Capacity		Air Flow	Static Pressure	Surface	Tube volume	Motor data (3/400V-50Hz)	Electric defrost Power			Fans	Noise	Conn. out	Drain connection	Weight
	SC3	SC4						Coil Power	Drain Pan Power	Power tot					
	[kW]	[kW]	m ²	dm ³	Δ	[kW]	[kW]				[kW]	[mm]	dB(A) 5m	Outlet	
12 mm fin spacing															
ABE501A12	9,92	7,92	14255	80	49,75	15,21	P= 780W l= 1.35 n= 1340min-1	7,4	1,5	8,9	2x500	66	48	2"	212
ABE501B12	12,32	9,85	13610	80	66,33	20,3		10,4	1,5	11,8	2x500	66	48	2"	216
ABE501C12	14,33	11,49	13028	80	82,91	25,36		13,3	1,5	14,8	2x500	66	48	2"	221
ABE502A12	20,45	16,34	28727	80	102,77	31,43		14,8	3,0	17,8	4x500	69	60	2"	423
ABE502B12	25,36	20,32	27485	80	137,03	41,91		20,7	3,0	23,7	4x500	69	60	2"	433
ABE502C12	29,49	23,68	26354	80	171,28	52,38		26,6	3,0	29,6	4x500	69	60	2"	442
ABE503A12	30,89	24,77	43194	80	155,79	47,65		22,0	4,4	26,4	6x500	71	76	2"	635
ABE503B12	38,3	30,78	41353	80	207,72	63,5		30,8	4,4	35,2	6x500	71	60x2	2"	649
ABE503C12	44,5	35,85	39674	80	259,65	79,4		39,6	4,4	44,0	6x500	71	60x2	2"	661
ABE504A12	41,34	32,72	57660	80	208,81	63,7		29,6	5,9	35,5	8x500	72	76	2"	847
ABE504B12	51,36	40,8	55220	80	278,42	85,15	41,4	5,9	47,4	8x500	72	60x2	2"	864	
ABE504C12	59,61	47,65	52993	80	348,02	106,4	53,3	5,9	59,2	8x500	72	60x2	2"	881	
ABE631A12	18,32	14,59	26932	100	89,90	27,49	P= 1800W l= 3.6 n= 1260min-1	12,6	1,8	14,4	2x630	80	60	2"	353
ABE631B12	22,85	18,25	25875	100	119,86	36,66		16,2	1,8	18,0	2x630	80	60	2"	359
ABE631C12	26,71	21,38	24915	100	149,83	45,82		19,8	1,8	21,6	2x630	80	60	2"	367
ABE632A12	37,58	29,88	54131	100	184,16	56,32		27,4	3,9	31,4	4x630	83	76	2"	706
ABE632B12	46,73	37,36	52071	100	245,54	75,1		35,3	3,9	39,2	4x630	83	60x2	2"	720
ABE632C12	54,59	43,76	50196	100	306,93	93,87		43,1	3,9	47,0	4x630	83	60x2	2"	734
ABE633A12	56,45	44,64	81325	100	278,42	85,15		41,4	5,9	47,4	6x630	85	60x2	2"	1059
ABE633B12	70,42	55,84	78262	100	371,22	113,5		53,3	5,9	59,2	6x630	85	76x2	2"	1080
ABE633C12	82,35	65,56	75471	100	464,03	141,9		65,1	5,9	71,0	6x630	85	76x2	2"	1101

*Nominal capacity according to ENV328 and Eurovent regulations (refrigerant R404A, $\Delta T_1 = T_{inAir} - T_{ev}$). Use external equalised thermostatic expansion valve.
Refrigerant R717A, $\Delta T_1 = T_{inAir} - T_{ev}$. Use external equalised thermostatic expansion valve.

Model	Capacity		Air Flow	Static Pressure	Surface	Tube volume	Motor data (3/400V-50Hz)	Electric defrost Power			Fans	Noise	Conn. In	Conn. out	Drain connection	Weight
	SC3	SC4						Coil Power	Drain Pan Power	Power tot						
	[kW]	[kW]	m ³ /h	Pa	m ²	dm ³	Δ				[kW]	[kW]	[kW]	dB(A) 5m	Inlet	Outlet
7 mm fin spacing																
ABA501A7	17,93	14,5	12653	80	114,8	21	P= 780W I _n = 1,35 n= 1340min ⁻¹	10,4	1,5	11,8	2x500	66	1"	1 1/4"	2"	225
ABA501B7	20,74	16,8	11759	80	153,1	28		13,3	1,5	14,8	2x500	66	1"	1 1/4"	2"	230
ABA502A7	36,89	29,71	25623	80	237,2	43,38		20,7	3,0	23,7	4x500	69	2x1"	2x1 1/4"	2"	450
ABA502B7	42,65	34,59	23872	80	316,2	57,84		26,6	3,0	29,6	4x500	69	2x1"	2x1"1/4"	2"	460
ABA503A7	55,85	44,99	38588	80	359,5	65,76		30,8	4,4	35,2	6x500	71	3x1"	3x1"1/4"	2"	675
ABA503B7	64,1	51,68	35979	80	479,3	87,68		39,6	4,4	44,0	6x500	71	2X1"	2X1 1/2"	2"	690
ABA504A7	74,45	59,98	51551	80	481,9	88,14		41,4	5,9	47,4	8x500	72	3x1"	3x1"1/4"	2"	900
ABA504B7	86,79	70,11	48084	80	642,5	117,5	53,3	5,9	59,2	8x500	72	3x1"	3x1 1/2"	2"	918	
ABA631A7	33,23	26,79	24294	100	207,4	37,94	P= 1800W I _n = 3,6 n= 1260min ⁻¹	16,2	1,8	18,0	2x630	80	2x1"	2X1"1/4"	2"	375
ABA631B7	38,78	31,33	22800	100	276,6	50,59		19,8	1,8	21,6	2x630	80	2x1"	2x1"1/4"	2"	382
ABA632A7	68,67	55,22	48980	100	425	77,73		35,3	3,9	39,2	4x630	83	3x1"	3x1"1/4"	2"	750
ABA632B7	80,46	64,96	46042	100	566,6	103,6		43,1	3,9	47,0	4x630	83	3x1"	3x1"1/4"	2"	765
ABA633A7	96,09	77,22	73660	100	642,5	117,5		53,3	5,9	59,2	6x630	85	3x1"	3x1"1/2"	2"	1125
ABA633B7	114,93	92,65	69277	100	856,6	156,7		65,1	5,9	71,0	6x630	85	3x1"	3x1"1/2"	2"	1148
10 mm fin spacing																
ABA501A10	14,89	12,03	13199	80	82,2	21	P= 780 I _n = 1,35 n= 1340min ⁻¹	10,4	1,5	11,8	2x500	66	1"	1 1/4"	2"	218
ABA501B10	17,88	14,43	12373	80	109,6	28		13,3	1,5	14,8	2x500	66	1"	1 1/4"	2"	223
ABA502A10	30,65	24,79	26687	80	169,8	43,38		20,7	3,0	23,7	4x500	69	2x1"	2x1 1/4"	2"	437
ABA502B10	36,68	29,71	25076	80	226,3	57,84		26,6	3,0	29,6	4x500	69	2x1"	2x1"1/4"	2"	446
ABA503A10	46,4	37,54	40169	80	257,3	65,76		30,8	4,4	35,2	6x500	71	3x1"	3x1"1/4"	2"	655
ABA503B10	56,16	45,39	37774	80	343,1	87,68		39,6	4,4	44,0	6x500	71	2X1"	2X1 1/2"	2"	669
ABA504A10	62,89	50,76	53650	80	344,9	88,14		41,4	5,9	47,4	8x500	72	3x1"	3x1"1/4"	2"	873
ABA504B10	75,52	61,14	50470	80	459,9	117,5	53,3	5,9	59,2	8x500	72	3x1"	3x1 1/2"	2"	890	
ABA631A10	27,34	22,03	25197	100	148,5	37,94	P= 1800W I _n = 3,6 n= 1260min ⁻¹	16,2	1,8	18,0	2x630	80	2x1"	2X1"1/4"	2"	364
ABA631B10	33,03	26,61	23829	100	198	50,59		19,8	1,8	21,6	2x630	80	2x1"	2x1"1/4"	2"	371
ABA632A10	57,26	46,2	50748	100	304,2	77,73		35,3	3,9	39,2	4x630	83	3x1"	3x1"1/4"	2"	728
ABA632B10	69,18	56,21	48067	100	405,6	103,6		43,1	3,9	47,0	4x630	83	3x1"	3x1"1/4"	2"	742
ABA633A10	83,12	67,04	76294	100	459,9	117,5		53,3	5,9	59,2	6x630	85	3x1"	3x1"1/2"	2"	1091
ABA633B10	101,73	82,04	72300	100	613,2	156,7		65,1	5,9	71,0	6x630	85	3x1"	3x1"1/2"	2"	1114
12mm fin spacing																
ABA501A12	13,49	10,87	13449	80	69,5	21	P= 780W I _n = 1,3 n=1340min ⁻¹	10,4	1,5	11,8	2x500	66	1"	1 1/4"	2"	212
ABA501B12	16,38	13,22	12660	80	92,6	28		13,3	1,5	14,8	2x500	66	1"	1 1/4"	2"	216
ABA502A12	27,68	22,39	27172	80	143,5	43,38		20,7	3,0	23,7	4x500	69	2x1"	2x1 1/4"	2"	423
ABA502B12	33,69	27,23	25638	80	191,4	57,84		26,6	3,0	29,6	4x500	69	2x1"	2x1"1/4"	2"	433
ABA503A12	41,91	33,9	40890	80	217,6	65,76		30,8	4,4	35,2	6x500	71	3x1"	3x1"1/4"	2"	635
ABA503B12	51,89	42,01	38610	80	290,1	87,68		39,6	4,4	44,0	6x500	71	2X1"	2X1 1/2"	2"	649
ABA504A12	57,15	46,21	54606	80	291,7	88,14		41,4	5,9	47,4	8x500	72	3x1"	3x1"1/4"	2"	847
ABA504B12	69,58	56,67	51581	80	388,9	117,5	53,3	5,9	59,2	8x500	72	3x1"	3x1 1/2"	2"	864	
ABA631A12	24,65	19,83	25609	100	125,6	37,94	P= 1800W I _n = 3,6 n= 1260min ⁻¹	16,2	1,8	18,0	2x630	80	2x1"	2X1"1/4"	2"	353
ABA631B12	30,13	24,28	24307	100	167,4	50,59		19,8	1,8	21,6	2x630	80	2x1"	2x1"1/4"	2"	359
ABA632A12	51,8	42,05	51553	100	257,2	77,73		35,3	3,9	39,2	4x630	83	3x1"	3x1"1/4"	2"	706
ABA632B12	63,42	51,52	49005	100	343	103,6		43,1	3,9	47,0	4x630	83	3x1"	3x1"1/4"	2"	720
ABA633A12	76,5	61,68	77492	100	388,9	117,5		53,3	5,9	59,2	6x630	85	3x1"	3x1"1/2"	2"	1059
ABA633B12	94,53	76,23	73698	100	518,5	156,7		65,1	5,9	71,0	6x630	85	3x1"	3x1"1/2"	2"	1080

Refrigerant R717A, ΔT1 = TINair - Tev. Use external equalised thermostatic expansion valve.

AlfaBlast

Drawings

Model	Application	Dimensions (mm)		
		A	B	C
AB 501	E/A	1373	1709	1028
AB 502	E/A	2183	1709	1028
AB 503	E/A	2993	1709	1028
AB 504	E/A	3803	1709	1028
AB 631	E/A	1643	2189	1048
AB 632	E/A	2723	2189	1048
AB 633	E/A	3803	2189	1048

We reserve the right to change our technical data without prior notice.

Ø 500 mm

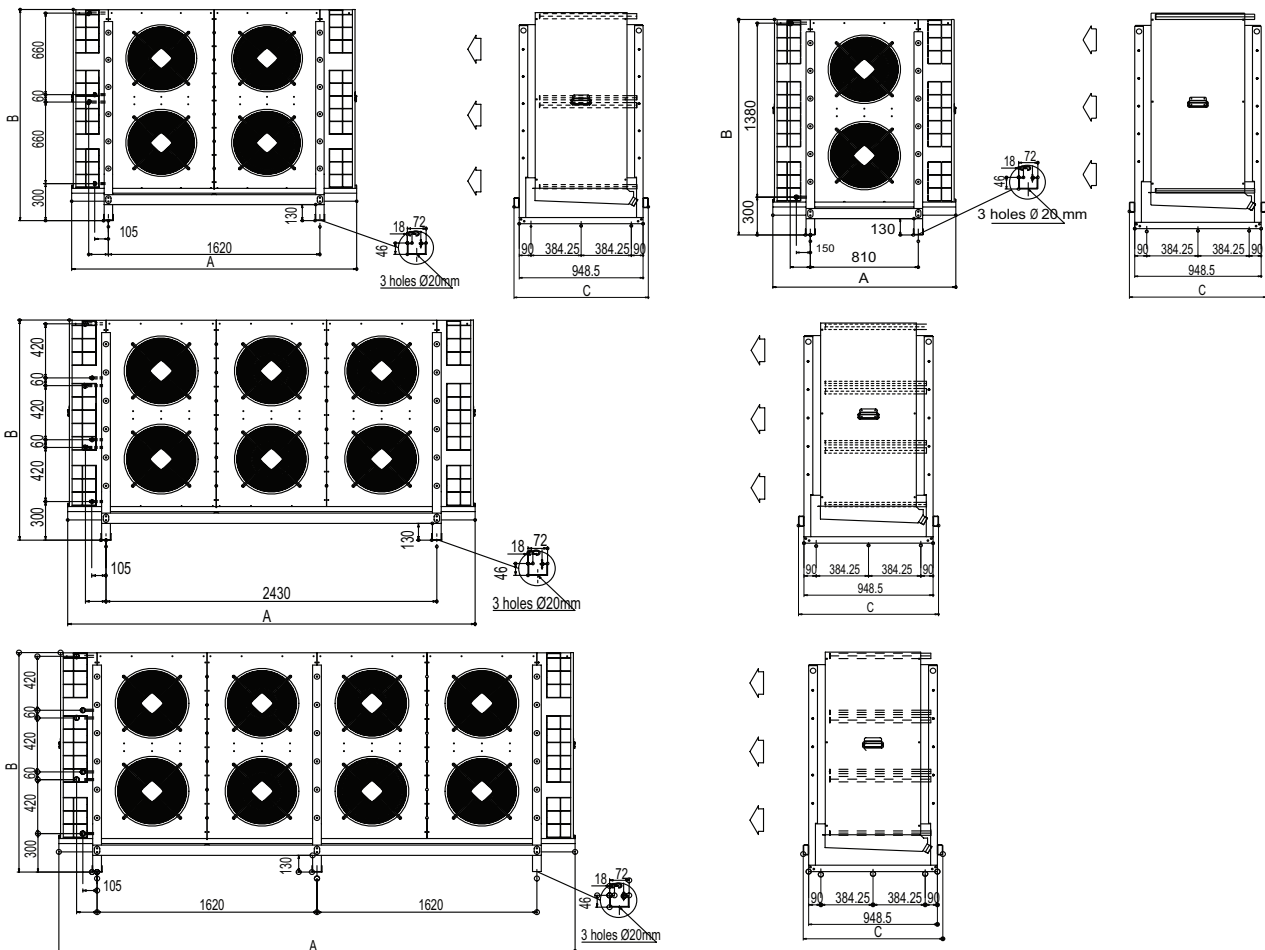

Ø 630 mm

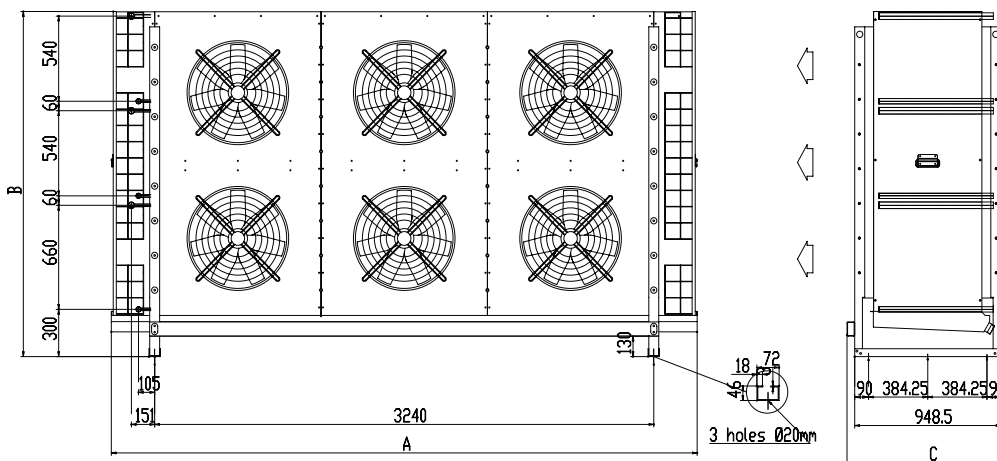
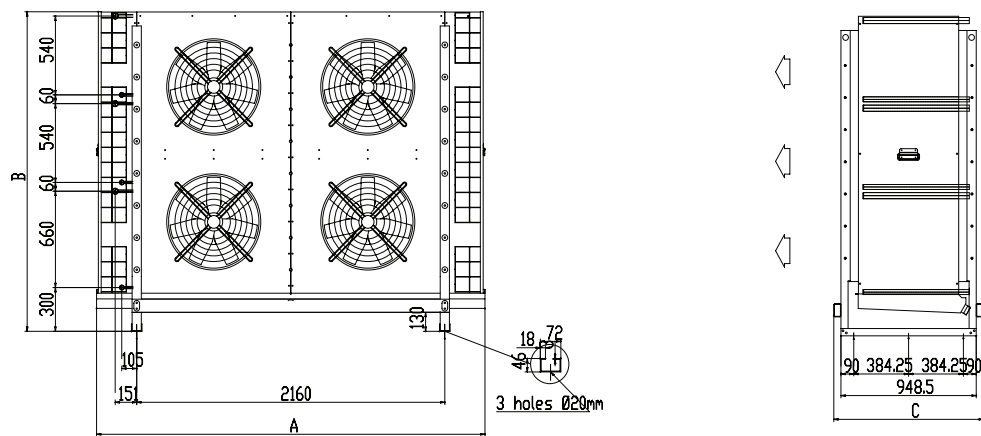
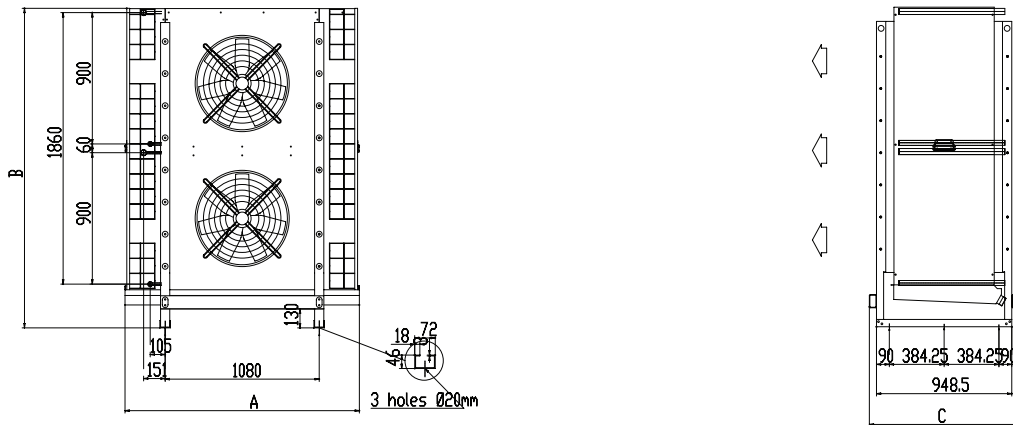

AlfaBlast

Options

Terminal Box

See Electrical Data Page.

Model:
ALL APPLICATIONS
 All Models

Fan Motor



Special fans 150 Pa

- 500 mm
- 630 mm

Model:
ALL APPLICATIONS
 All Models

Local safety switch wired

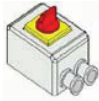

See Electrical Data Page.

Model:
ALL APPLICATIONS
 All Models

Coil Treatment / Material

Pre-coated fins: Epoxy-coated, pre-painted aluminium fins.

Cataphoresis treatment: An electrolytic process is achieved by submerging the coil in a paint bath, where it acts as a cathode and gets completely coated in an epoxy paint, which gives exceptional protection against corrosion. Recommended for alkaline or saline atmospheres.

Applications: More information on corrosion prevention can be found in the Miscellaneous section

Model:
 All Models

Cabinet made entirely of stainless steel

Casework component in stainless steel AISI 304.



Application Use: More information on corrosion prevention can be found in the Miscellaneous section.

Model:
ALL APPLICATIONS
 All Models

Cabinet made entirely in AL-Mg₃Casework component in AL-Mg₃.

Application Use: More information on corrosion prevention can be found in the Miscellaneous section.

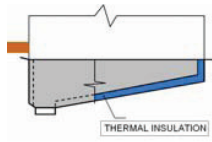
Model:
ALL APPLICATIONS
 All Models

Insulated drip tray		
	<p>Construction: Sandwich manufactured with two aluminium shells and 12mm of polyethylene insulation in between.</p> <p>Features: The insulation prevents water condensing on the bottom side of the drip-tray and reduces the transfer of the defrost heat into the cold room. It can be combined with Electrical or Hot Gas defrost.</p> <p>Applications: Room temperatures below -25°C and food processing rooms.</p>	<p>Model: ALL APPLICATIONS All Models</p>
Fan ring heater (FRH)		
	<p>Application: To prevent the freezing up of the fan blades at the collar in extremely humid conditions during defrost in cooling or freezing rooms.</p> <p>Supply conditions: Electric heater with stainless steel shell, stainless steel fixing spring and connection box.</p>	<p>Model: ALL APPLICATIONS All Models</p>

AlfaBlast

Electrical Data

Connection box for electric fan motor

Function

Junction box complete with screw-on cover, cable glands and terminal strip.

General data

Material: sheet of steel

IP Protection Class: Min IP55

Colour: Grey RAL 7032

Insulation Class: I

Ambient Temp.: min. -25°C, max. +50°C

Weight: approx. 4Kg

Dimensions

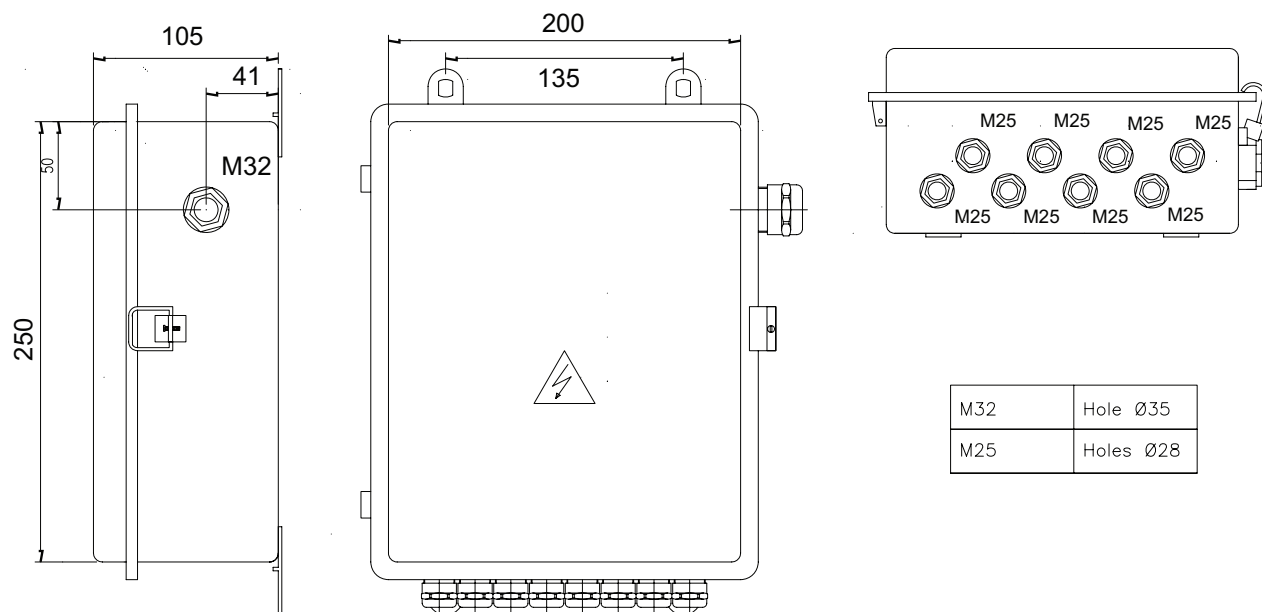

Electric wiring diagram

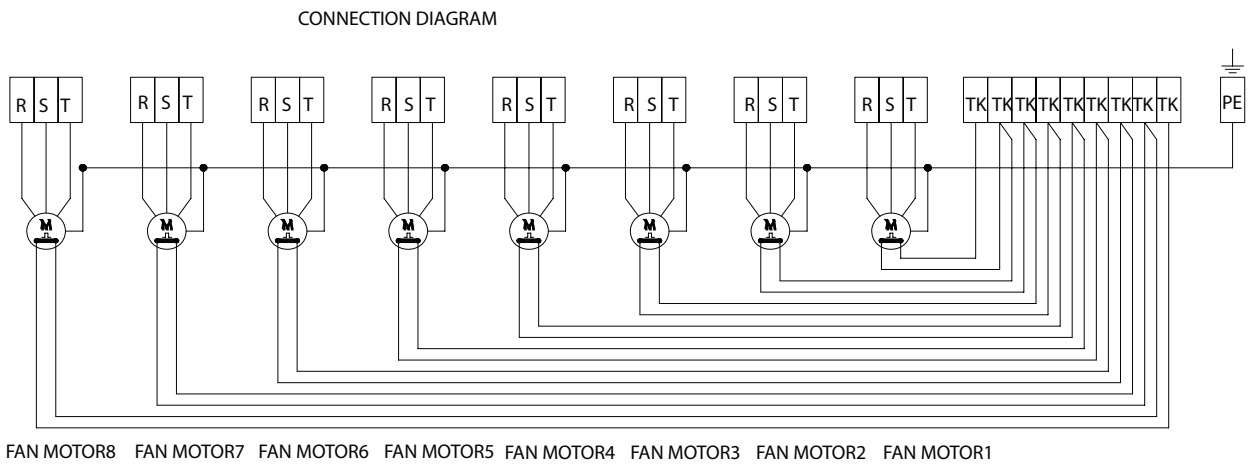
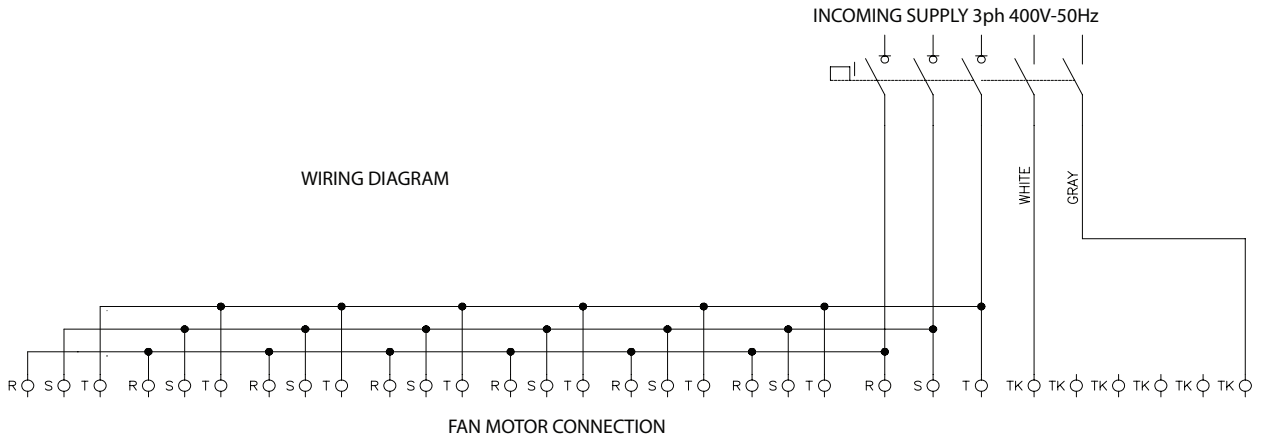

Connection box for electric fan motor

Function

Junction box complete with screw-on cover, cable glands and terminal strip.

General data

Material: sheet of steel
 IP Protection Class: Min IP55
 Colour: Grey RAL 7032
 Insulation Class: I
 Ambient Temp.: min. -25°C, max. +50°C
 Weight: approx. 4Kg

Dimensions

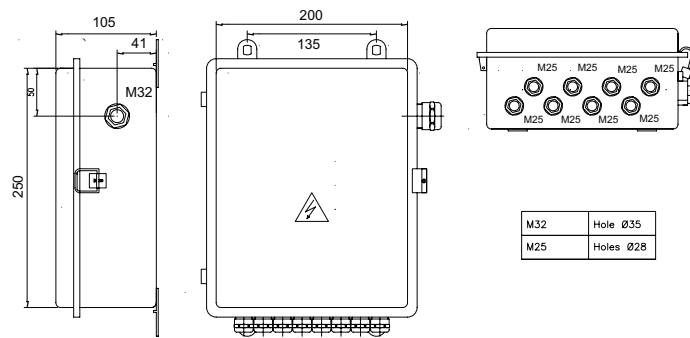

Electric wiring diagram

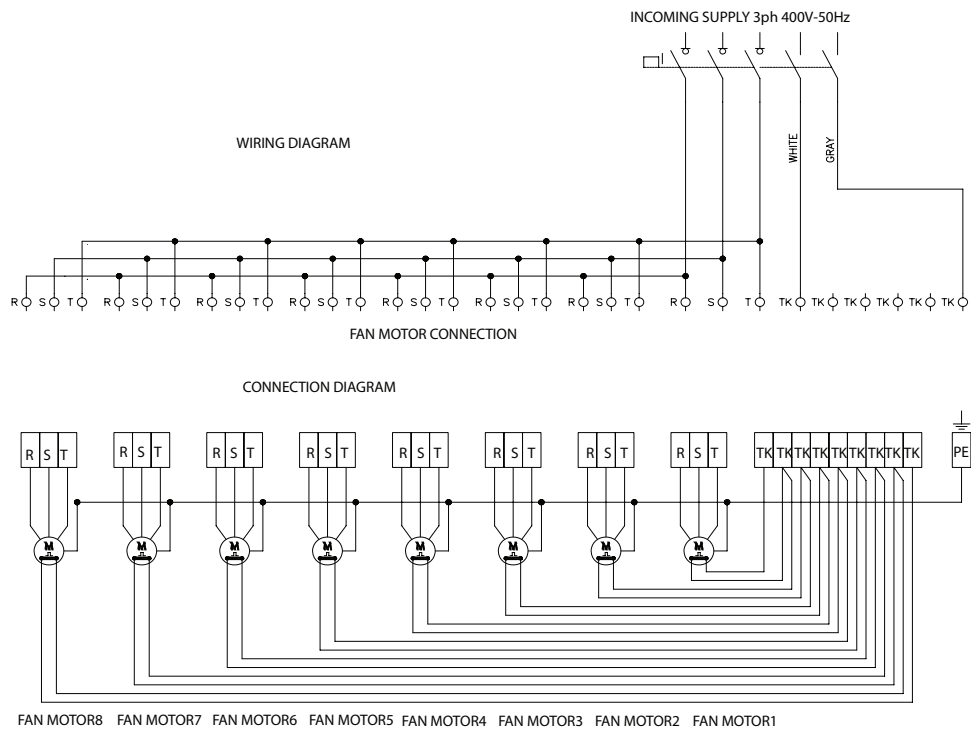

Connection box for electric defrost

Function

Junction box complete with screw-on cover, cable glands and terminal strip.

General data

Material: sheet of steel
 IP Protection Class: Min IP55
 Colour: Grey RAL 7032
 Insulation Class: I
 Ambient Temp.: min. -25°C, max. +50°C
 Weight: approx. 4Kg

Dimensions

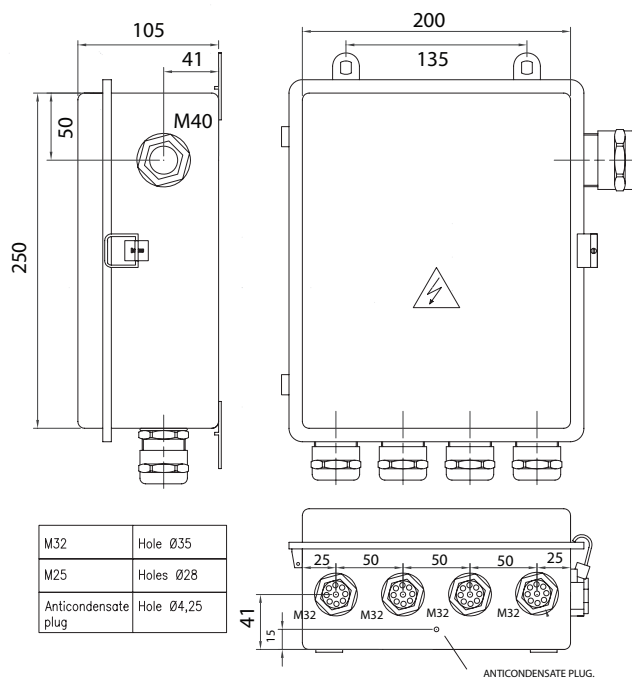

Electric wiring diagram

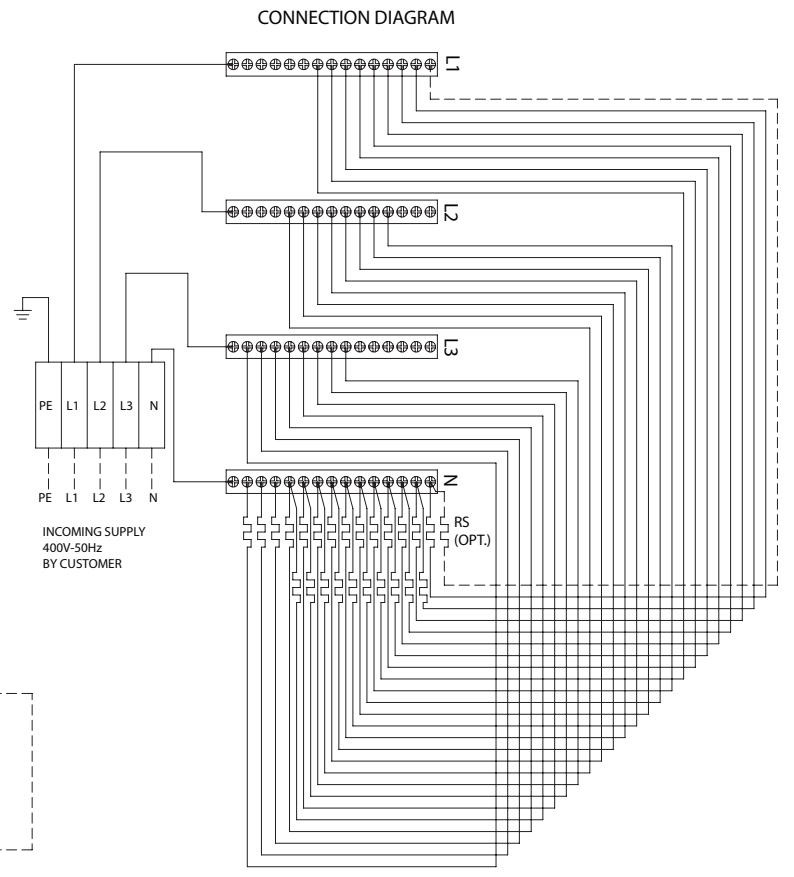
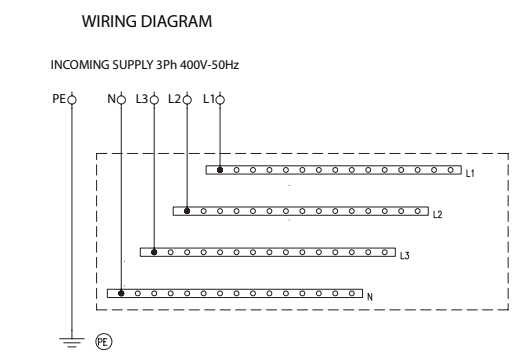
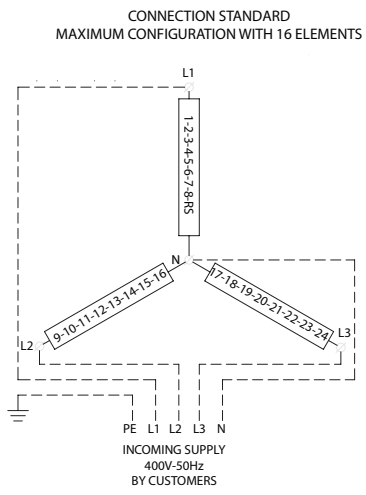

AlfaBlast

Electric Heater

ALL SERIES

Function

The elements are designed to operate in a refrigeration field with high moisture rate.

Special care is taken in selecting the power supply, cables and insulation materials.

General data

Model	Coil		Drip Tray	
	N° heater	P(W)	N° heater	P(W)
ABE501A	10	7400	2	1480
ABE501B	14	10360	2	1480
ABE501C	18	13320	2	1480
ABE502A	10	14800	2	2960
ABE502B	14	20720	2	2960
ABE502C	18	26640	2	2960
ABE503A	10	22000	2	4400
ABE503B	14	30800	2	4400
ABE503C	18	39600	2	4400
ABE504A	10	29600	2	5920
ABE504B	14	41440	2	5920
ABE504C	18	53280	2	5920
ABA501A	14	10360	2	1480
ABA501B	18	13320	2	1480
ABA502A	14	20720	2	2960
ABA502B	18	26640	2	2960
ABA503A	14	30800	2	4400
ABA503B	18	39600	2	4400
ABA504A	14	41440	2	5920
ABA504B	18	53280	2	5920

We reserve the right to change our technical data without prior notice.

Model	Coil		Drip Tray	
	N° heater	P(W)	N° heater	P(W)
ABE631A	14	12600	2	1800
ABE631B	18	16200	2	1800
ABE631C	22	19800	2	1800
ABE632A	14	27440	2	3920
ABE632B	18	35280	2	3920
ABE632C	22	43120	2	3920
ABE633A	14	41440	2	5920
ABE633B	18	53280	2	5920
ABE633C	22	65120	2	5920
ABE631A	18	16200	2	1800
ABE631B	22	19800	2	1800
ABE632A	18	35280	2	3920
ABE632B	22	43120	2	3920
ABE633A	18	53280	2	5920
ABE633B	22	65120	2	5920

We reserve the right to change our technical data without prior notice.

AlfaBlast

Code description

Code No.	1	2	3	4	5	6	7	8	
	AB	150	E	S	50	2	A	7	E
1) Fan type									
150	Fan motor 150pa Standard pressure								
2) Application									
E	Direct Expansion ev.								
A	Ammonia pump ev.								
3) Noise level									
S	Standard noise level								
L	Low noise level, only for Standard pressure								
4) Fan diameter									
50	500 mm								
63	630 mm								
5) Two fans:									
1-3	500 and 630mm								
4	500 mm								
6) Coil Size									
A	E and A application								
B	E and A application								
C	Only E application								
7) Fin Spacing									
7 mm									
10 mm									
12 mm									
6) Defrost type									
A	Air defrost								
E	Electrical defrost (coil + drip tray)								
HG	Hot Gas defrost (coil + drip tray)								
W	Water defrost only								
HG+E	Combined: HG on coil + E on drip tray								

General Alfa Select Air Legend

		Description 1		Description 2	
D	D fan cabling (three phase)	BSFT	Basic Switch Board + Speed Control Temp. + Signal	AL	Aluminium fin
Y	Y fan cabling (three phase)	BI	Basic Switch Board + Frequency Converter (Inverter)	CU	Copper fin
D/Y	D/Y fan cabling (three phase), single speed fan motor	BSI	Basic Switch Board + Frequency Converter (Inverter) + Signal	PR	Pre-coated fin
S	Single phase	C	Switch Board + Cooling fan	SS	Stainless steel tube
P	Packaged on a pallet	R	Switch Board + Resistor	TH	Thermoguard treatment
CR	Packaged in a crate	F	Switch Board + Cooling fan + Resistor	CF	Cataphoresis treatment
BO	Packaged in a box	PT	Ammonia pump top	SC	Sub-cooling circuit
Feet	Feet-mounted	PB	Ammonia pump bottom	kW	Spray water kit
SW	Safety Switch	AL	Aluminium casing	FL	Flanges
CB	Terminal Box	SS	Stainless Steel casing	FH	Fan ring heater
B	Basic Switch Board	AP	Pre-painted Aluminium casing	IS	Insulated Drip Tray
BS	Basic Switch Board + Signal	PL	Plastic casing	RH	Reheating coil
BP	Basic Switch Board + Step Control Pressure	E	Electrical defrost	SR	Air socket adapter ring
BT	Basic Switch Board + Step Control Temperature	LE	Low Electrical defrost	CW	Air throw fan cowling
BSP	Basic Switch Board + Step Control Pressure + Signal	A	Air Defrost	ER	120° elbow reducer
BST	Basic Switch Board + Step Control Temp. + Signal	HG	Hot Gas Defrost	HN	Hinged fan cowling
BFP	Basic Switch Board + Speed Control Pressure	HG+E	Hot Gas Defrost + Electrical Defrost on drip tray		
BFT	Basic Switch Board + Speed Control Temperature	W	Water Defrost		
BSFP	Basic Switch Board + Speed Control Pres. + Signal	W+E	Water Defrost + Electrical Defrost on drip tray		

Note: valid for the entire product range

Centrifugal Units

General Content

General Features

Most of our unit coolers are available in the following versions:

- Direct expansion evaporators
- Brine unit coolers
- Pump ammonia evaporators

Certifications and reliability

Alfa Laval quality systems fully comply with ISO 9001, and all of our products are manufactured in strict accordance with CE regulations.

Fin spacing

In our experience, fin spacing should correspond to both the goods stored and the room's air temperature, as follows:

Series	Green Line
Product	Fruit / Vegetables
Room temperature	10 ÷ 0°C
Fin spacing	3 ÷ 4,5mm

Capacity

The standard conditions are in accordance with EN 328. The cooling capacities stated in the catalogue are the nominal capacities for Qn (wet conditions), in compliance with Eurovent regulations. In standard Qst conditions (dry), the nominal capacities are calculated with the following formula:

$$Q_n = Q_{st} \times \text{Wet Coil Factor}$$

Standard conditions	Air Inlet Temp °C	Evaporation Temp.(dew point) °C	R.H.	Wet Coil Factor
SC1	10	0	85%	1,35
SC2	0	-8	85%	1,15
SC3	-18	-25	95%	1,05
SC4	-25	-31	95%	1,01

The nominal capacities are calculated with refrigerant R404A. For different refrigerants the following factors should be applied:

Refrigerant	SC1	SC2	SC3	SC4
R134a	0,93	0,91	0,85	-
R22	0,95	0,05	0,95	0,95
R507	0,97	0,97	0,95	0,95
R404A	1	1	1	1

See the fin material factors below:

Fin material	Factor
Aluminium	1
Coated Aluminium	0,97
Copper	1,03



Relative humidity ΔT

The cold room hygrometric conditions are defined by the room temperature and the working ΔT. At positive cold room temperatures ΔT has an influence on the relative humidity (RH).

Data Sound

Lp(A) is the A-weighted sound pressure level in a room with an absorption area of 100 m² (Sabine), with the observation point at a distance of 5 m and 45° horizontally below the middle point of the fans. Lw(A) is the A-weighted sound power level measured according to EN13487; annex C.

m	1	2	3	4	5
dB (A)	6	4	2	1	0

Defrost

All our coolers come equipped with several different defrosting systems. For room temperatures where ice build-up is likely, and where the ambient room temperature is below 0°C, a unit with a defrosting system is needed

Test and cleaning

The coils are cleaned and dehydrated in order to remove any traces of oil. Each heat exchanger undergoes a pressure and leak test with dry air at 30 bar, before being supplied with a nitrogen pre-charge.

Guarantee

All our products are protected under warranty for 18 months from the shipping date. In the unlikely event of a defect occurring within the warranty period, please return the equipment or faulty part free of charge to us, where we will decide whether to repair or replace the goods. Unfortunately, We cannot take responsibility for damage caused by the misuse or incorrect installation of our products. Brochure subject to technical changes without prior notice

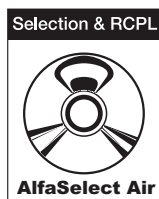

We recommend that you use the Alfa Select software for an exact thermal and mechanical design.



ISC

Product description

Applications

Series with centrifugal fans, designed for sock applications and mainly in working and packing rooms above 0°C, where it is necessary to have low air velocity and uniform hygrometric conditions. Cold room capacities ranging from 150 to 1500m³. The units are designed for quick and easy maintenance with immediate access to key inspection areas. This series is available as a: DX evaporator, NH₃ pump evaporator and as a brine unit cooler.

Standard design

Coil

Coil manufactured from corrugated aluminium fins and copper tubes with a diameter of 16mm.

Only one fin spacing is available: 4.2mm

Casing

The casing is manufactured from aluminium sheets and is suitable for applications where a high degree of hygiene is required.

Options

- Pre-coated fin
- Cataphoresis treatment
- Stainless steel tubes with aluminium or pre-coated fins
- Casing in stainless steel
- External static pressure available 50, 100, 200 Pa
- Filters
- Defrost :
 - Electric (E)
 - Hot Gas (HG)
 - Water (W)
 - Hot Gas in the coil and Electric in the drip tray (HG-E)
 - Water + electric (W-E)

Benefits

- High static pressure
- Suitable for sock cooling
- Low noise level
- Flexible design (contact Alfa Laval)

Fans

Three-phase motor 400V-50/60Hz, 4-pole. Protection class IP 55. External static pressure available as standard 150 Pa. Two V-belts drives.

The fans are suitable for operation in air temp. application between 0°C and +40°C.

For air temperature lower than +20°C, the full load current (FLC) can be calculated by using the correction factor table. The overload protectors should have a 20% margin to accommodate fan motor supplier variations.

T [°C]	20	10	0
Fc	1	1,04	1,08



Model	Capacity		Air Flow	Static Pressure	Surface	Tube volume	Motor data (3/400V-50Hz)	Fans	Electric defrost Power				Noise	Conn. In	Conn. out
	SC1	SC2							Electric	Elec. +Hot gas	Water				
	[kW]	[kW]	m ³ /h	Pa	m ²	dm ³	N°	[kW]			[kW]	l/h	kPa	dB(A) 5m	Inlet
4,2 mm fin spacing															
ISC-1412	18,38	12,43	9275	150	81,5	19	P=1500W I=3,5A n=600min ⁻¹	1	7,9	1,6	3050	12	68	5/8" SAE	35 mm
ISC-1612	23,99	16,35	9204	150	122,3	29		1	11,0	1,6	4520	16	68	22 mm	35 mm
ISC-1912	29,75	20,42	9101	150	183,4	44		1	15,7	1,6	6800	18	68	28 mm	42 mm
ISC-1416	26,69	17,95	14325	150	108,7	26	P=2200W I=4,8 n=560min ⁻¹	1	9,5	1,6	4050	16	73	28 mm	42 mm
ISC-1616	35	23,78	14191	150	163	39		1	14,2	1,6	4520	16	73	35 mm	48 mm
ISC-1916	43,79	29,99	13997	150	244,6	58		1	18,9	1,6	9080	25	73	35 mm	48 mm
ISC-2416	53,73	36,16	28656	150	219	51		2	18,6	3,1	8100	23	76	35 mm	54 mm
ISC-2616	70,37	47,84	28393	150	328,6	77		2	27,9	3,1	12200	35	76	35 mm	54 mm
ISC-2916	87,97	60,28	28009	150	492,8	115		2	37,2	3,1	18280	35	76	35 mm	60 mm

Nominal capacity according to ENV328 and Eurovent regulations (refrigerant R404A, DT1 = TINair - T_{ev}). Use external equalised thermostatic expansion valve.

ISC

Drawings

Model	Dimensions (mm)									
	A	B	C	D	E	F	G	H	P	Q
4,2 mm fin spacing										
ISC-1412	2450	920	1010	750	2000	-	490	700	400	470
ISC-1612	2450	920	1010	750	2000	-	490	700	400	470
ISC-1912	2450	920	1010	750	2000	-	490	700	400	470
ISC-1416	2450	1160	1135	750	2000	-	585	950	480	560
ISC-1616	2450	1160	1135	750	2000	-	585	950	480	560
ISC-1916	2450	1160	1135	750	2000	-	585	950	480	560
ISC-2416	4450	1160	1135	750	4000	2000	585	950	480	560
ISC-2616	4450	1160	1135	750	4000	2000	585	950	480	560
ISC-2916	4450	1160	1135	750	4000	2000	585	950	480	560

We reserve the right to change our technical data without prior notice.

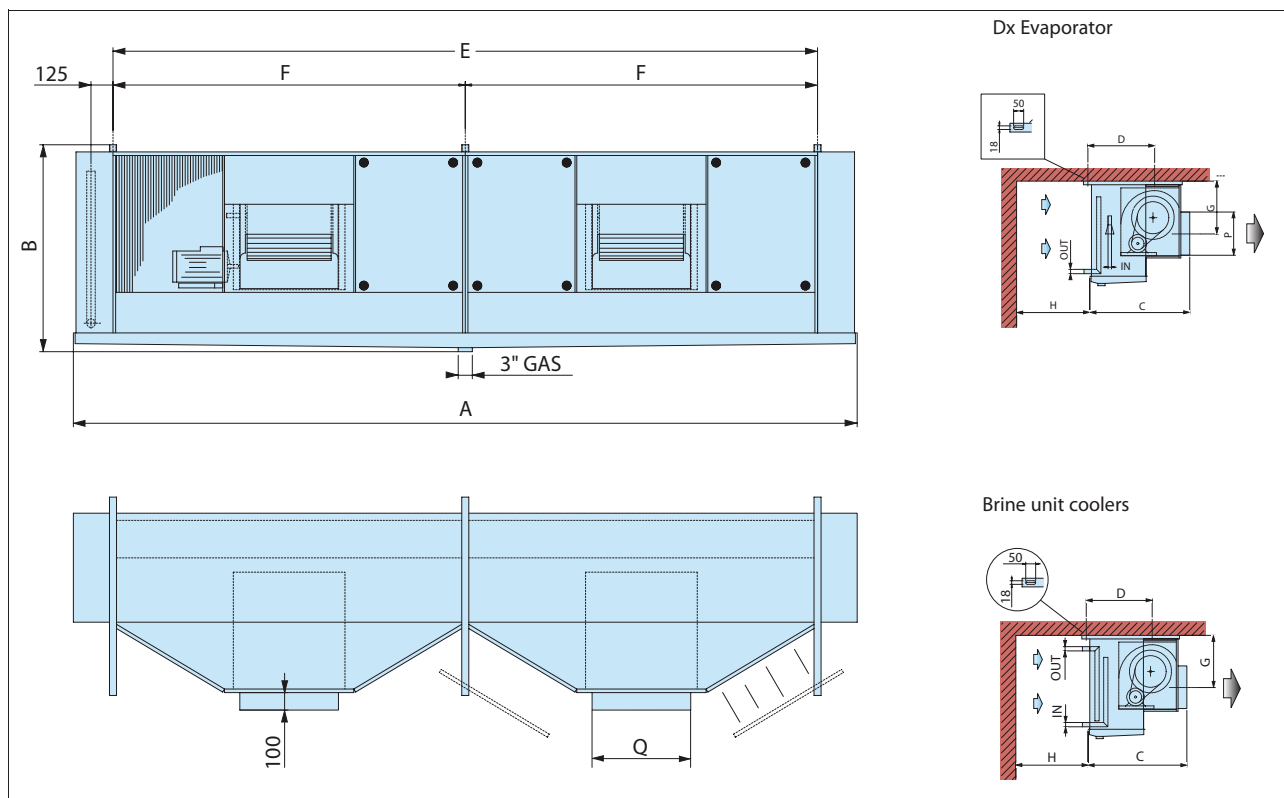

<h1>ISC</h1>		
<h2>Options</h2>		
Non-standard static pressure		
	Available external static pressure: 50, 100, 200 Pa	Model: ALL APPLICATIONS All Models
Coil Treatment / Material		
	<p>Pre-coated fins: Epoxy-coated, pre-painted aluminium fins.</p> <p>Cataphoresis treatment: An electrolytic process is achieved by submerging the coil in a paint bath, where it acts as a cathode and gets completely coated in an epoxy paint, which gives exceptional protection against corrosion. Recommended for alkaline or saline atmospheres.</p> <p>Stainless steel tubes with aluminium fins</p> <p>Stainless steel tubes with pre-coated fins</p> <p>Application use: More information on corrosion prevention can be found in the Miscellaneous section</p>	Model: All Models
Cabinet made entirely of stainless steel		
	Casework component in stainless steel AISI 304. Application Use: More information on corrosion prevention can be found in the Miscellaneous section.	Model: ALL APPLICATIONS All Models
Filter PRE-FIL/MCF		
		Model: ALL APPLICATIONS All Models

ISC

Electric Heater

ALL SERIES

Function

The elements are designed to operate in a refrigeration field with high moisture rate.

Special care is taken in selecting the power supply, cables and insulation materials.

General data

Model	ELECTRICAL DEFROST		ELECTRICAL ELEMENT	
	COIL		DRAIN LINE	
	N° heater	P(W)	N° heater	P(W)
ISC-1412	3	4710	2	1900
ISC-1612	5	7850	2	1900
ISC-1912	8	12560	2	1900
ISC-1416	4	6280	2	1900
ISC-1616	7	10990	2	1900
ISC-1916	10	15700	2	1900
ISC-2416	4	12400	2	3700
ISC-2616	7	21700	2	3700
ISC-2916	10	31000	2	3700

We reserve the right to change our technical data without prior notice.

ISC

Code description

Code No.

ISC	1	9	12	S	E
-----	---	---	----	---	---

Series	Product	Room Temperature	Fin Spacing
ISC	Daily Product	from 12 to 0°C	4,2 mm

1) 1, 2 fans

2) Progressive Number

3) Coil size

4) Application

S	Direct expansion evaporation
P	Brine unit cooler
A	Ammonia pump ev.

5) Defrost

A	Air defrost
E	Electric defrost
HG	Hot gas defrost
W	Water defrost
HG+E	Hot Gas in the coil and Electric on drip tray
W+E	Water and Electric on drip tray

General Alfa Select Air Legend

		Description 1	Description 2
D	D fan cabling (three phase)	BSFT	Basic Switch Board + Speed Control Temp. + Signal
Y	Y fan cabling (three phase)	BI	Basic Switch Board + Frequency Converter (Inverter)
D/Y	D/Y fan cabling (three phase), single speed fan motor	BSI	Basic Switch Board + Frequency Converter (Inverter) + Signal
S	Single phase	C	Switch Board + Cooling fan
P	Packaged on a pallet	R	Switch Board + Resistor
CR	Packaged in a crate	F	Switch Board + Cooling fan + Resistor
BO	Packaged in a box	PT	Ammonia pump top
Feet	Feet-mounted	PB	Ammonia pump bottom
SW	Safety Switch	AL	Aluminium casing
CB	Terminal Box	SS	Stainless Steel casing
B	Basic Switch Board	AP	Pre-painted Aluminium casing
BS	Basic Switch Board + Signal	PL	Plastic casing
BP	Basic Switch Board + Step Control Pressure	E	Electrical defrost
BT	Basic Switch Board + Step Control Temperature	LE	Low Electrical defrost
BSP	Basic Switch Board + Step Control Pressure + Signal	A	Air Defrost
BST	Basic Switch Board + Step Control Temp. + Signal	HG	Hot Gas Defrost
BFP	Basic Switch Board + Speed Control Pressure	HG+E	Hot Gas Defrost + Electrical Defrost on drip tray
BFT	Basic Switch Board + Speed Control Temperature	W	Water Defrost
BSFP	Basic Switch Board + Speed Control Pres. + Signal	W+E	Water Defrost + Electrical Defrost on drip tray
		AL	Aluminium fin
		CU	Copper fin
		PR	Pre-coated fin
		SS	Stainless steel tube
		TH	Thermoguard treatment
		CF	Cataphoresis treatment
		SC	Sub-cooling circuit
		KW	Spray water kit
		FL	Flanges
		FH	Fan ring heater
		IS	Insulated Drip Tray
		RH	Reheating coil
		SR	Air socket adapter ring
		CW	Air throw fan cowling
		ER	120° elbow reducer
		HN	Hinged fan cowling

Note: valid for the entire product range

AlfaBlue Condensers

General Contents

General Features

All products are designed to satisfy both commercial and industrial refrigeration, air conditioning, and retail refrigeration. All axial condensers are available in the following versions:

- Vertical installation (V)
- Horizontal installation (H)
- Most common refrigerant HFC, such as R404A, R507C, R407C, R134a
- A dedicated product line is available for the natural refrigerant NH₃

Relative footprint, low consumption and low noise levels are the keys to this series' success.

Certifications and reliability

All Air Cooled condensers are guaranteed by Eurovent "Certify All". Alfa Laval quality systems fully comply with ISO 9001, and all of our products are manufactured in strict accordance with CE regulations.

Capacity

The standard conditions are in accordance with EN 327 (R404A, T. air = 25°C, T.cond.= 40°C, ΔT sub-cool < 3K, ΔT superheat = 25K).

How to work out the condenser's capacity:

$$Q_c = Q_f \times F_r \times F_1 \times F_2 \times F_3 \times F_4 \times F_5 \times F_6$$

Q_c = Condenser capacity

Q_f = Evaporator capacity

F_r = Condensing Temp (T_c) and evaporating Temp factor. (T_e).

F₁ = Compressor factor

F₂ = Refrigerant factor

F₃ = ΔT factor (15/ΔT)

F₄ = Altitude factor

F₅ = Fin material

F₆ = Ambient temperature factor

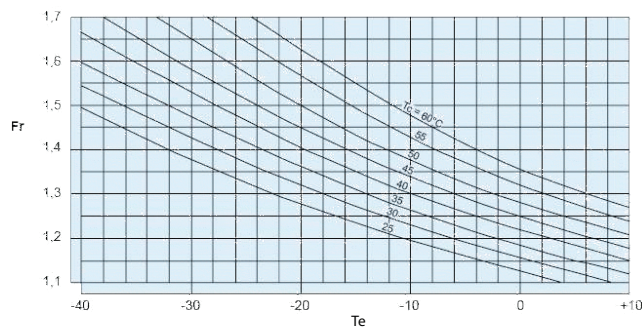

Compressor	Open	Semi-hermetic	Hermetic
F1	1	1,08	1,14

Refrigerant	R507A	R404A	R134a	R22	R407C
F2	1	1	0,93	0,96	0,87

Altitude (m)	0	500	1000	1500	2000
F4	1	1,028	1,06	1,09	1,12

Fin material	Al	Al Prv	Cu
F5	1	1,03	0,97

Ambient Temp.	15	20	25	30	35
F6	0,975	0,988	1,00	1,013	1,026

Tube Protection



Due to the thermal expansion of the copper pipes, all metal sheets are equipped with an aluminium plate with collars. This plate supports the tube and therefore the pipes must not come into contact with the metal sheets. With this solution, the vibrations and thermal expansion are absorbed by friction cannot occur. The rigidity of the coil is sustained effectively.

Energy Efficiency Class

Energy efficiency class of air cooled condensers		
Class	Energy consumption	R
A	Extremely low	R>110
B	Very low	70≤R<110
C	Low	45≤R<70
D	Medium	30≤R<45
E	High	R<30

R = Condenser capacity (ΔT15K) / motor power consumption.

HEAT EXCHANGERS
Highest efficiency

A

B

C

D

E

GUARANTEED

Test and cleaning

The coils are cleaned and dehydrated in order to remove any traces of oil.

Each heat exchanger undergoes a pressure and leak test with dry air at 34 bar, before being supplied with a nitrogen pre-charge.



Sound Data

The sound pressure level is based on the calculation (according to EN 13487) of the sound pressure level on the surface of a cuboid area which is at a 10 metre distance and is parallel to the reference envelope of the sound source. (Standard sound pressure level; annex C EN 13487)

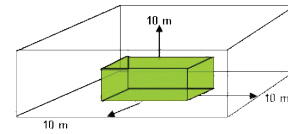

Sound pressure correction for distances other than 10 metres.

Distance (m)	2	3	4	5	7	10	15	20	30	40	50	60	80
Correction dB(A)	11	8,5	7	5	2,5	0	-3	-5,5	-9	-11	-12	-14	-16

Sound pressure level for several fans at nominal speed rating.

N° units	2	3	4	5	6	7	8	9	10
dB(A)	3	5	6	7	8	8,5	9	9,5	10

To calculate the sound pressure level, take the sound power of the individual fans according to their position, and calculate the sound propagation taking into consideration the local and ambient conditions. Speed change, start-up and control noises are not taken into account.

Fan Model	Speed rpm		Total Lw dB(A)		LW octave band spectrum dB(A)															
					63Hz		125Hz		250Hz		500Hz		1 000Hz		2 000Hz		4 000Hz		8 000Hz	
Connection	Δ	Y	Δ	Y	Δ	Y	Δ	Y	Δ	Y	Δ	Y	Δ	Y	Δ	Y	Δ	Y		
630 S	1340	1070	90	84	-	-	68	66	76	72	78	74	83	77	81	76	78	72	70	65
630 L	900	690	77	71	-	-	62	55	69	63	72	65	75	68	72	63	64	56	58	50
630 Q	650	480	70	62	-	-	51	48	60	55	63	58	65	59	60	53	53	47	46	45
630 R	430	330	60	54	-	-	46	45	53	47	54	51	53	49	48	43	43	40	42	41
800 S	880	660	83	76	-	-	69	56	67	62	74	69	78	74	79	72	72	64	62	54
800 L	680	530	76	71	-	-	57	49	62	57	69	63	74	68	72	63	65	55	55	45
800 Q	440	340	66	60	-	-	47	42	57	48	59	54	63	56	58	51	50	43	39	34
800 R	380	240	63	52	-	-	47	42	54	44	57	47	59	48	55	42	47	34	35	26
910 T	890	700	90	83	-	-	72	70	79	73	82	76	84	79	82	76	79	73	73	66
910 S	860	660	85	79	-	-	72	70	79	73	82	76	84	79	82	76	79	73	73	66
910 L	640	440	78	70	-	-	68	62	73	68	76	70	77	70	76	70	73	67	66	60
910 Q	440	330	68	62	-	-	57	49	61	58	64	57	67	60	61	53	52	45	43	35
910 R	390	250	65	53	-	-	56	46	59	45	59	46	61	49	56	44	48	35	38	22
1000 L	680	550	86	81	-	-	58	53	68	60	70	63	73	68	75	67	71	62	62	53
1000 Q	425	325	72	65	-	-	50	45	58	50	62	54	65	58	60	50	54	42	44	30
1000 R	390	260	70	61	-	-	50	44	56	45	60	49	64	52	55	44	48	36	37	25

Guarantee

All our products are protected under warranty for 18 months from the shipping date. If a defect should occur within the warranty period, please return the equipment or part to our factory free of charge where we will repair or replace the goods, depending on what is required. Unfortunately, We cannot take responsibility for damage caused by the misuse or incorrect installation of our products. The brochure is subject to technical changes without prior notice

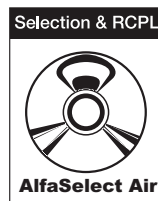

We recommend that you use the Alfa Select Air software for a precise thermal and mechanical design.



BCM - Single Fan Row

Product description

Application

The Alfa Laval Condenser can be used in refrigeration and air conditioning equipment

Standard design

Coil

The innovative heat exchanger gives excellent heat transfer with minimised refrigerant charge, thanks to the new fin corrugations developed by Alfa Laval, combined with advance cross-fin tubes. The standard heat exchanger is manufactured from copper tubes and aluminium fins with 2.1mm spacing.

Casing

Casework made with pre-painted galvanized steel sheets. A new frame design provides high rigidity for heavy applications. The new system protects the heat exchanger tubes completely during transportation and against vibration and thermal expansion while in operation.

Supports manufactured in galvanized steel, with optimized length to permit uniform air suction in the coil.

Benefits

- Footprint: optimized footprint with higher capacity
- 630, 800, 910, 1000 mm fan:
 - More performance available
 - Low power consumption fan motor
 - More options on noise levels
 - Flexible design
- RAL 9002 all parts painted:
 - No cut edges
 - Higher corrosion resistance, double surface treatment
 - External Corrosion Class C4
- Coil design: increased heat transfer thanks to innovative fin corrugations
- Casing: strong casing with new design
- High Energy Efficiency: best performance with low energy consumption

Options

- Non-standard fin spacing: for heavy dusty environment
- Multi-circuits: total capacity split in multiple compressor lines
- Sub-cooling circuit. Additional circuit to further cool the condensate
- Coil treatment: corrosion resistance, ideal for aggressive environments
- Vibration Dampers: for reducing vibrations
- Electrical parts:
 - Switch on/off: local safety switch wired to isolate the fan and also the switch EMC type
 - Terminal Box: all fans wired for an easy electrical connection
 - Switchboard
- Cabling: ready to install



- Frequency Converter design: units can run under frequency control (when air temperature is below the design, it allows energy saving, noise reduction and longer fan motor life)
- Fan Step Control:
 - Energy saving
 - Cheapest method of controlling performance
- Fan Speed Control:
 - Energy saving
 - Noise reduction when the air temperature is below the design temperature.
 - Variable and efficient speed control according to the heat rejected
 - Better performance control
- Special fans:
 - 480/3ph-60Hz IP54: High adaptability for every market
 - IP 55: High protection fan for use in tropical or desert areas
 - High temperature Electric Motors: for use when the air temperature is higher than permitted for the use of standard fans.

Fans

Four different fan diameters are available for the BCM: 630, 800, 910, 1000 mm. Diameter 630, 800, 910, 1000 mm with three-phase motor 400V-50Hz, for 630 (L, Q, R) also single-phase 230V-50Hz. The motors come with external rotors, protection class IP 54 according to DIN 40050. This Axial Condenser BCM is available in five noise levels: (S) standard, (L) low, (Q) quiet, (R) residential and the new (T) high performance fan. The motors are fitted with a thermal contact. The fans are suitable for operation in air temp. application between -40°C and +40°C. For air temperature lower than +20°C, the full load current (FLC) can be calculated by using the correction factor table. The overload protectors should have a 20% margin to accommodate fan motor supplier variations.

T [°C]	20	10	0	-10	-15	-20	-25	-30
Fc	1	1,04	1,08	1,12	1,14	1,16	1,18	1,2

Model	Capacity [kW]			Airflow [m³/h]		Lp [dB(A)]*		Motor (3/400V-50Hz)		Motor (1/230V 50Hz)	Fans N° x D [mm]	E.E.C.**		Surface m²	Tube vol- ume dm³	Conn. Size				
	Δ	Y	1/230V 50Hz	Δ	Y	Δ	Y	Δ	Y			Δ	Y			Inlet	Outlet			
Ø 630																				
BCMS 631 B	57,8	47,0	-	16302	12311	56	50	P=2600 W I _n =4.8A n=1310 min-1	P=1600W I _n =2.7A n=1000 min-1	-	1X630	E	D	80,1	12	35	28			
BCMS 631 C	62,7	49,9	-	15426	11563	56	50				1X630	E	D	106,8	16	35	28			
BCMS 632 B	115,9	94,5	-	32398	24442	59	53				2X630	E	D	156,7	23	48	35			
BCMS 632 C	125,8	99,9	-	30595	22914	59	53				2X630	E	D	208,9	31	48	35			
BCMS 633 B	173,4	141,3	-	48490	36570	61	55				3X630	E	D	233,3	34	60	48			
BCMS 633 C	188,1	149,3	-	45760	34262	61	55				3X630	E	D	311,1	46	60	48			
BCMS 634 B	226,5	186,5	-	64581	48697	62	56				4X630	E	D	309,9	45	76	54			
BCMS 634 C	247,8	198,0	-	60924	45609	62	56	4X630	E	D	413,2	61	76	54						
BCML 631 A	32,1	27,9	31,9	9513	7865	45	40	P=690W I _n =1.25A n=900 min-1	P=480W I _n =0.78A n=690 min-1	P=780W I _n =3.5A n=900 min-1	1X630	C	C	53,4	8	35	28			
BCML 631 B	37,3	32,0	37,1	9112	7421	45	40				1X630	C	B	80,1	12	35	28			
BCML 631 C	40,1	33,4	39,7	8731	7022	45	40				1X630	C	B	106,8	16	35	28			
BCML 632 A	64,8	56,4	64,5	18964	15660	48	43				2X630	C	C	104,5	15	42	28			
BCML 632 B	75,1	63,5	74,6	18135	14747	48	43				2X630	C	B	156,7	23	48	35			
BCML 632 C	79,1	65,7	78,4	17350	13931	48	43				2X630	C	B	208,9	31	48	35			
BCML 633 A	96,9	84,4	96,6	28414	23453	50	45				3X630	C	C	155,5	23	54	42			
BCML 633 B	112,3	95,0	111,5	27155	22070	50	45				3X630	C	B	233,3	34	60	48			
BCML 633 C	118,3	98,2	117,2	25968	20838	50	45				3X630	C	B	311,1	46	60	48			
BCML 634 A	126,3	109,9	125,8	37864	31246	51	46				4X630	C	C	206,6	30	60	48			
BCML 634 B	149,3	126,6	148,3	36176	29394	51	46				4X630	C	B	309,9	45	76	54			
BCML 634 C	157,6	130,3	156,2	34584	27745	51	46				4X630	C	B	413,2	61	76	54			
BCMQ 631 A	25,3	21,7	25,3	6875	5505	38	31				P=330W, I _n =0.80A n=650 min-1	P=190W, I _n =0.38A n=480 min-1	P=400W, I _n =1.8A n=650 min-1	1X630	B	A	53,4	8	35	28
BCMQ 631 B	29,1	23,9	29,1	6546	5150	38	31							1X630	B	A	80,1	12	35	28
BCMQ 631 C	30,1	24,0	30,1	6240	4840	38	31	1X630	B	A				106,8	16	35	28			
BCMQ 632 A	51,1	43,1	51,1	13699	10952	41	34	2X630	B	A				104,5	15	42	28			
BCMQ 632 B	57,2	47,0	57,2	13019	10224	41	34	2X630	B	A				156,7	23	48	35			
BCMQ 632 C	59,4	47,3	59,4	12392	9594	41	34	2X630	B	A				208,9	31	48	35			
BCMQ 633 A	76,5	64,4	76,5	20521	16399	43	36	3X630	B	A				155,5	23	54	42			
BCMQ 633 B	85,6	70,3	85,6	19491	15297	43	36	3X630	B	A				233,3	34	60	48			
BCMQ 633 C	88,9	70,7	88,8	18542	14346	43	36	3X630	B	A				311,1	46	60	48			
BCMQ 634 A	99,5	85,1	99,5	27343	21845	44	37	4X630	B	A				206,6	30	60	48			
BCMQ 634 B	114,3	93,1	114,3	25962	20370	44	37	4X630	B	A				309,9	45	76	54			
BCMQ 634 C	117,5	93,7	117,5	24693	19098	44	37	4X630	B	A				413,2	61	76	54			
BCMR 631 A	18,7	15,6	-	4506	3565	28	22	P=125W I _n =0.33A n=430 min-1	P=85W, I _n =0.14A n=330 min-1	-				1X630	A	A	53,4	8	35	28
BCMR 631 B	20,3	16,3	-	4268	3326	28	22							1X630	A	A	80,1	12	35	28
BCMR 632 A	36,8	30,7	-	8975	7092	31	25				2X630	A	A	104,5	15	42	28			
BCMR 632 B	40,2	32,2	-	8482	6601	31	25				2X630	A	A	156,7	23	48	35			
BCMR 633 A	55,0	45,9	-	13444	10618	33	27				3X630	A	A	155,5	23	54	42			
BCMR 633 B	60,1	48,1	-	12696	9875	33	27				3X630	A	A	233,3	34	60	48			
BCMR 634 A	73,6	61,3	-	17912	14144	34	28				4X630	A	A	206,6	30	60	48			
BCMR 634 B	79,5	63,8	-	16910	13149	34	28				4X630	A	A	309,9	45	76	54			

Nominal capacities according to standard ENV327(R404A T_{air}=25°C, T_{cond}=40°C, ΔT_{subcool}<3K, ΔT_{superheat}=25K).

*See "General Contents" for more details.

**Energy Efficiency Class: see "General Contents" for more details.

Model	Capacity [kW]			Air flow [m ³ /super>3</super>/h]		Lp [dB(A)]*		Motor (3/400V-50Hz)		Motor (1/230V 50Hz)	Fans	E.E.C.**		Surface	Tube volume	Conn. Size		
	Δ	Y	1/230V 50Hz	Δ	Y	Δ	Y	Δ	Y		N° x D [mm]	Δ	Y	m ²	dm ³	mm		
																Inlet	Outlet	
Ø 630 LONG																		
BCMS 631 B L	65,0	52,9	-	17203	13141	56	50	P=2600W I _n =4.8A n=1310 min-1	P=1600W I _n =2.7A n=1000 min-1		1X630	E	D	101,9	15	35	28	
BCMS 631 C L	70,7	56,2	-	16606	12582	56	50				1X630	E	D	135,9	20	42	28	
BCMS 632 B L	129,1	105,1	-	34302	26180	59	53				2X630	E	D	200,3	29	54	42	
BCMS 632 C L	140,4	111,5	-	33067	25034	59	53				2X630	E	D	267	39	54	42	
BCMS 633 B L	192,3	157,7	-	51398	39217	61	55				3X630	E	D	298,7	44	60	48	
BCMS 633 C L	210,2	167,7	-	49527	37485	61	55	3X630	E	D	398,2	58	76	54				
BCML 631 A L	35,4	31,0	35,4	9785	8182	45	40	P=690W I _n =1.25A n=900 min-1	P=480W I _n =0.78A n=690 min-1	P=780W I _n =3.5A n=900 min-1	1X630	C	B	67,9	10	35	28	
BCML 631 B L	40,8	35,2	40,7	9514	7866	45	40				1X630	B	B	101,9	15	35	28	
BCML 631 C L	43,6	36,7	43,3	9245	7566	45	40				1X630	B	B	135,9	20	42	28	
BCML 632 A L	70,5	61,6	70,4	19538	16327	48	43				2X630	C	B	133,5	20	48	35	
BCML 632 B L	81,2	69,9	80,8	18980	15677	48	43				2X630	C	B	200,3	29	54	42	
BCML 632 C L	86,7	72,8	86,1	18427	15062	48	43	2X630	B	B	267	39	54	42				
BCML 633 A L	106,1	93,0	106,0	29290	24470	50	45	3X630	C	B	199,1	29	54	42				
BCML 633 B L	122,5	104,6	122,0	28444	23488	50	45	3X630	B	B	298,7	44	60	48				
BCML 633 C L	129,1	108,3	128,3	27608	22558	50	45	3X630	B	B	398,2	58	76	54				
BCMQ 631 A L	27,8	23,8	27,8	7104	5767	38	31	P=330W I _n =0.80A n=650 min-1	P=190W I _n =0.38A n=480 min-1	P=400W I _n =1.8A n=650 min-1	1X630	B	A	67,9	10	35	28	
BCMQ 631 B L	31,5	26,1	31,5	6876	5506	38	31				1X630	A	A	101,9	15	35	28	
BCMQ 631 C L	32,7	26,4	32,7	6654	5264	38	31				1X630	A	A	135,9	20	42	28	
BCMQ 632 A L	55,2	47,2	55,2	14180	11503	41	34				2X630	B	A	133,5	20	48	35	
BCMQ 632 B L	62,7	51,9	62,7	13711	10967	41	34				2X630	B	A	200,3	29	54	42	
BCMQ 632 C L	65,0	52,4	65,0	13256	10473	41	34	2X630	A	A	267	39	54	42				
BCMQ 633 A L	83,5	70,9	83,5	21256	17237	43	36	3X630	B	A	199,1	29	54	42				
BCMQ 633 B L	93,3	77,2	93,4	20546	16427	43	36	3X630	B	A	298,7	44	60	48				
BCMQ 633 C L	96,8	78,1	96,8	19858	15681	43	36	3X630	A	A	398,2	58	76	54				
BCMR 631 A L	20,2	16,9	-	4666	3739	28	22	P=125W I _n =0.33A n=430 min-1	P=85W I _n =0.14A n=330 min-1		1X630	A	A	67,9	10	35	28	
BCMR 631 B L	21,9	17,7	-	4507	3566	28	22				1X630	A	A	101,9	15	35	28	
BCMR 632 A L	40,1	33,5	-	9313	7457	31	25				2X630	A	A	133,5	20	48	35	
BCMR 632 B L	43,6	35,2	-	8984	7102	31	25				2X630	A	A	200,3	29	54	42	
BCMR 633 A L	59,7	49,9	-	13960	11175	33	27				3X630	A	A	199,1	29	54	42	
BCMR 633 B L	64,9	52,5	-	13462	10637	33	27	3X630	A	A	298,7	44	60	48				

Nominal capacities according to standard ENV327(R404A T_{air}=25°C, T_{cond}=40°C, ΔT_{subcool}<3K, ΔT_{superheat}=25K).

*See "General Contents" for more details.

**Energy Efficiency Class: see "General Contents" for more details.

Model	Capacity [kW]		Airflow [m³/h]		Lp [dB(A)]*		Motor (3/400V-50Hz)		Fans	E.E.C.**		Sur-face	Tube volume	Conn. Size	
	Δ	Y	Δ	Y	Δ	Y	Δ	Y	N° x D [mm]	Δ	Y	m²	dm³	mm	
														Inlet	Outlet
Ø 800															
BCMS 801 B	81,9	66,9	20650	15935	51	46	P=2000W I _n =4A n=880min ⁻¹	P=1250W I _n =2,3A n=680min ⁻¹	1X800	C	C	147,6	21	42	28
BCMS 801 C	87,4	69,5	19748	15071	51	46			1X800	C	C	196,8	28	42	28
BCMS 802 B	163,2	133,2	41166	31739	54	49			2X800	C	C	291	43	54	42
BCMS 802 C	174,0	138,2	39330	29988	54	49			2X800	C	C	388,1	56	60	48
BCMS 803 A	174,0	151,6	66791	52721	56	51			3X800	D	D	492,2	43	60	48
BCMS 803 B	218,5	187,1	64848	50701	56	51			3X800	D	C	738,3	64	76	54
BCMS 803 C	246,0	204,7	62929	48767	56	51			3X800	C	C	984,5	86	76	54
BCMS 804 A	237,8	207,4	89034	70272	57	52			4X800	D	D	654,8	57	76	54
BCMS 804 B	295,0	249,9	86432	67570	57	52			4X800	D	C	982,1	86	76	54
BCMS 804 C	329,0	271,6	83865	64983	57	52			4X800	C	C	1309,5	114	76	54
BCMS 805 A	296,6	260,0	111277	87824	58	53	5X800	D	D	817,3	71	76	54		
BCMS 805 B	369,9	314,4	108017	84438	58	53	5X800	D	C	1225,9	107	88,9	60		
BCMS 805 C	413,5	342,1	104800	81199	58	53	5X800	C	C	1634,6	143	88,9	60		
BCML 801 A	58,0	50,1	16637	13586	44	40	P=1050W I _n =24A n=680min ⁻¹	P=770W I _n =15A n=530min ⁻¹	1X800	C	B	98,4	14	35	28
BCML 801 B	66,9	56,0	15917	12802	44	40			1X800	B	B	147,6	21	42	28
BCML 801 C	70,1	57,7	15229	12102	44	40			1X800	B	B	196,8	28	42	28
BCML 802 A	115,5	99,7	33205	27093	47	43			2X800	C	B	194	28	54	42
BCML 802 B	133,1	111,3	31733	25497	47	43			2X800	B	B	291	43	54	42
BCML 802 C	139,6	114,6	30331	24078	47	43			2X800	B	B	388,1	56	60	48
BCML 803 A	149,2	132,4	51369	42463	49	45			3X800	C	C	492,2	43	60	48
BCML 803 B	185,3	161,1	49933	40781	49	45			3X800	C	B	738,3	64	76	54
BCML 803 C	203,8	172,8	48493	39192	49	45			3X800	B	B	984,5	86	76	54
BCML 804 A	204,2	181,4	68476	56599	50	46			4X800	C	C	654,8	57	76	54
BCML 804 B	247,2	213,6	66554	54348	50	46	4X800	C	B	982,1	86	76	54		
BCML 804 C	270,5	229,6	64627	52223	50	46	4X800	B	B	1309,5	114	76	54		
BCML 805 A	256,1	228,2	85584	70735	51	47	5X800	C	C	817,3	71	76	54		
BCML 805 B	311,1	269,3	83175	67916	51	47	5X800	C	B	1225,9	107	88,9	60		
BCML 805 C	340,7	287,9	80760	65254	51	47	5X800	B	B	1634,6	143	88,9	60		
BCMQ 801 A	40,6	33,1	10297	7974	35	28	P=370W I _n =1,2A n=440min ⁻¹	P=200W I _n =0,5A n=340min ⁻¹	1X800	A	A	98,4	14	35	28
BCMQ 801 B	44,8	35,6	9772	7465	35	28			1X800	A	A	147,6	21	42	28
BCMQ 801 C	45,6	35,3	9281	7025	35	28			1X800	A	A	196,8	28	42	28
BCMQ 802 A	80,7	65,8	20542	15896	38	31			2X800	A	A	194	28	54	42
BCMQ 802 B	89,1	70,8	19470	14862	38	31			2X800	A	A	291	43	54	42
BCMQ 802 C	90,8	70,2	18473	13973	38	31			2X800	A	A	388,1	56	60	48
BCMQ 803 A	109,9	94,8	31968	25077	40	33			3X800	B	A	492,2	43	60	48
BCMQ 803 B	131,1	106,9	30906	23938	40	33			3X800	A	A	738,3	64	76	54
BCMQ 803 C	138,1	110,7	29852	22899	40	33			3X800	A	A	984,5	86	76	54
BCMQ 804 A	150,2	126,4	42613	33424	41	34			4X800	A	A	654,8	57	76	54
BCMQ 804 B	173,7	143,7	41191	31900	41	34	4X800	A	A	982,1	86	76	54		
BCMQ 804 C	186,0	148,8	39780	30510	41	34	4X800	A	A	1309,5	114	76	54		
BCMQ 805 A	189,6	159,8	53258	41770	42	35	5X800	A	A	817,3	71	76	54		
BCMQ 805 B	218,2	178,7	51475	39862	42	35	5X800	A	A	1225,9	107	88,9	60		
BCMQ 805 C	231,3	185,1	49708	38122	42	35	5X800	A	A	1634,6	143	88,9	60		
BCMR 801 A	35,8	24,8	8803	5529	31	20	P=250W I _n =0,62A n=380min ⁻¹	P=110W I _n =0,27A n=240min ⁻¹	1X800	A	A	98,4	14	35	28
BCMR 801 B	39,0	25,4	8300	5128	31	20			1X800	A	A	147,6	21	42	28
BCMR 802 A	71,3	49,3	17555	11016	34	23			2X800	A	A	194	28	54	42
BCMR 802 B	77,7	50,5	16532	10203	34	23			2X800	A	A	291	43	54	42
BCMR 803 A	100,5	74,0	27485	17496	36	25			3X800	A	A	492,2	43	60	48
BCMR 803 B	115,9	79,3	26423	16599	36	25			3X800	A	A	738,3	64	76	54
BCMR 803 C	120,9	79,2	25407	15779	36	25			3X800	A	A	984,5	86	76	54
BCMR 804 A	135,1	98,3	36636	23318	37	26			4X800	A	A	654,8	57	76	54
BCMR 804 B	155,0	106,5	35214	22118	37	26			4X800	A	A	982,1	86	76	54
BCMR 804 C	162,7	106,1	33855	21022	37	26			4X800	A	A	1309,5	114	76	54
BCMR 805 A	170,7	122,1	45786	29140	38	27	5X800	A	A	817,3	71	76	54		
BCMR 805 B	192,6	132,5	44005	27637	38	27	5X800	A	A	1225,9	107	88,9	60		
BCMR 805 C	202,4	132,2	42303	26265	38	27	5X800	A	A	1634,6	143	88,9	60		

Nominal capacities according to standard ENV327(R404A Tair=25°C, Tcond=40°C, ΔTsubcool=3K, ΔTsuperheat=25K).

*See "General Contents" for more details.

**Energy Efficiency Class: see "General Contents" for more details.

Model	Capacity [kW]		Airflow [m³/h]		Lp [dB(A)]*		Motor (3/400V-50Hz)		Fans	E.E.C.**		Surface	Tube volume	Conn. Size	
	Δ	Y	Δ	Y	Δ	Y	Δ	Y	N° x D [mm]	Δ	Y	m²	dm³	mm	
														Inlet	Outlet
Ø 910															
BCMT 901 B	115,1	98,3	30615	24823	55	50	P=3600W I _n =7.2A n=890min-1	P=2500W I _n =4.3A n=700min-1	1X900	D	D	176,3	25	42	28
BCMT 901 C	124,1	103,9	29339	23505	55	50			1X900	D	C	235	34	42	28
BCMT 902 B	227,3	195,2	61080	49485	58	53			2X900	D	D	348,4	50	60	48
BCMT 902 C	247,5	207,0	58472	46808	58	53			2X900	D	E	464,6	67	60	48
BCMT 903 A	236,3	214,2	97197	81109	60	55			3X900	E	D	589,7	51	60	48
BCMT 903 B	300,2	265,5	95395	78612	60	55			3X900	E	D	884,6	77	76	54
BCMT 903 C	341,3	295,3	93167	75938	60	55			3X900	D	D	1179,5	103	76	54
BCMT 904 A	315,4	287,2	129582	108125	61	56			4X900	E	D	784,8	68	76	54
BCMT 904 B	403,0	357,7	127166	104781	61	56			4X900	E	D	1177,2	103	76	54
BCMT 904 C	459,6	398,7	124181	101203	61	56			4X900	D	D	1569,6	137	88,9	60
BCMS 901 B	88,1	72,0	21539	16780	53	48	P=1650W I _n =3.5A n=860min-1	P=1000W I _n =1.8A n=660min-1	1X900	C	B	176,3	25	42	28
BCMS 901 C	93,7	75,1	20753	16039	53	48			1X900	C	B	235	34	42	28
BCMS 902 B	175,4	143,9	42983	33469	56	51			2X900	C	B	348,4	50	60	48
BCMS 902 C	186,8	149,7	41383	31965	56	51			2X900	C	B	464,6	67	60	48
BCMS 903 A	194,4	168,6	68521	54240	58	53			3X900	D	C	589,7	51	60	48
BCMS 903 B	238,7	201,6	67026	52710	58	53			3X900	C	C	884,6	77	76	54
BCMS 903 C	264,6	220,3	65472	51170	58	53			3X900	C	B	1179,5	103	76	54
BCMS 904 A	261,7	227,8	91348	72306	59	54			4X900	D	C	784,8	68	76	54
BCMS 904 B	322,4	272,8	89347	70260	59	54			4X900	C	C	1177,2	103	76	54
BCMS 904 C	357,7	295,6	87268	68200	59	54			4X900	C	B	1569,6	137	88,9	60
BCML 901 A	60,6	46,6	16566	11686	46	39	P=900W I _n =2.2A n=640min-1	P=470W I _n =1.05A n=440min-1	1X900	B	B	117,5	17	42	28
BCML 901 B	69,0	51,2	15929	11056	46	39			1X900	B	A	176,3	25	42	28
BCML 901 C	72,2	51,8	15329	10512	46	39			1X900	B	A	235	34	42	28
BCML 902 A	120,9	92,9	33081	23319	49	42			2X900	B	B	232,3	34	54	42
BCML 902 B	138,0	101,4	31784	22043	49	42			2X900	B	A	348,4	50	60	48
BCML 902 C	143,9	103,1	30566	20944	49	42			2X900	B	A	464,6	67	60	48
BCML 903 A	162,2	129,6	51050	36525	51	44			3X900	C	B	589,7	51	60	48
BCML 903 B	193,2	150,7	49739	35100	51	44			3X900	B	A	884,6	77	76	54
BCML 903 C	211,8	160,1	48463	33817	51	44			3X900	B	A	1179,5	103	76	54
BCML 904 A	219,4	175,8	68054	48687	52	45			4X900	C	B	784,8	68	76	54
BCML 904 B	261,6	200,4	66301	46782	52	45	4X900	B	A	1177,2	103	76	54		
BCML 904 C	283,1	212,1	64595	45067	52	45	4X900	B	A	1569,6	137	88,9	60		
BCMQ 901 A	43,8	36,4	10801	8592	36	30	P=330W I _n =0.83A n=440min-1	P=185W I _n =0.38A n=330min-1	1X900	A	A	117,5	17	42	28
BCMQ 901 B	48,4	39,3	10347	8126	36	30			1X900	A	A	176,3	25	42	28
BCMQ 901 C	49,1	38,8	9917	7709	36	30			1X900	A	A	235	34	42	28
BCMQ 902 A	87,4	72,7	21565	17144	39	33			2X900	A	A	232,3	34	54	42
BCMQ 902 B	95,9	77,9	20641	16199	39	33			2X900	A	A	348,4	50	60	48
BCMQ 902 C	97,8	77,3	19768	15355	39	33			2X900	A	A	464,6	67	60	48
BCMQ 903 A	121,5	105,1	33345	26802	41	35			3X900	A	A	589,7	51	60	48
BCMQ 903 B	142,2	119,1	32430	25805	41	35			3X900	A	A	884,6	77	76	54
BCMQ 903 C	150,9	122,8	31525	24864	41	35			3X900	A	A	1179,5	103	76	54
BCMQ 904 A	165,0	140,7	44452	35727	42	36			4X900	A	A	784,8	68	76	54
BCMQ 904 B	188,2	157,9	43228	34393	42	36	4X900	A	A	1177,2	103	76	54		
BCMQ 904 C	200,2	163,0	42017	33136	42	36	4X900	A	A	1569,6	137	88,9	60		
BCMR 901 A	41,5	29,1	10081	6496	35	25	P=270W I _n =0.70A n=390min-1	P=140W I _n =0.32A n=250min-1	1X900	A	A	117,5	17	42	28
BCMR 901 B	45,6	30,3	9632	6110	35	25			1X900	A	A	176,3	25	42	28
BCMR 902 A	82,7	58,0	20124	12960	38	28			2X900	A	A	232,3	34	54	42
BCMR 902 B	90,3	60,2	19212	12178	38	28			2X900	A	A	348,4	50	60	48
BCMR 903 A	116,0	86,7	31189	20378	40	30			3X900	A	A	589,7	51	60	48
BCMR 903 B	135,0	94,3	30269	19514	40	30			3X900	A	A	884,6	77	76	54
BCMR 903 C	142,1	94,6	29371	18728	40	30			3X900	A	A	1179,5	103	76	54
BCMR 904 A	157,3	114,9	41577	27163	41	31			4X900	A	A	784,8	68	76	54
BCMR 904 B	178,8	125,2	40347	26008	41	31			4X900	A	A	1177,2	103	76	54
BCMR 904 C	188,5	125,8	39146	24958	41	31			4X900	A	A	1569,6	137	88,9	60

Nominal capacities according to standard ENV327(R404A T_{air}=25°C, T_{cond}=40°C, ΔT_{subcool}<3K, ΔT_{superheat}=25K).

*See "General Contents" for more details.

**Energy Efficiency Class: see "General Contents" for more details.

Model	Capacity [kW]		Airflow [m³/h]		Lp [dB(A)]*		Motor (3/400V-50Hz)		Fans	E.E.C.**		Surface	Tube volume	Conn. Size		
	Δ	Y	Δ	Y	Δ	Y	Δ	Y	N° x D [mm]	Δ	Y	m²	dm³	mm		
																Inlet
Ø 1000																
BCML 1001 A	88,8	76,1	29354	23020	54	49	P=2200W I _n =4.2A n=670min ⁻¹	P=1500W I _n =2.7A n=530min ⁻¹	1X1000	D	C	117,5	17	42	28	
BCML 1001 B	105,5	86,8	27234	21153	54	49			1X1000	C	C	176,3	26	42	28	
BCML 1001 C	110,5	89,2	25358	19574	54	49			1X1000	C	C	235	34	42	28	
BCML 1002 A	177,5	151,8	58532	45880	57	52			2X1000	D	C	232,3	34	54	42	
BCML 1002 B	208,8	172,6	54229	42101	57	52			2X1000	C	C	348,4	51	60	48	
BCML 1002 C	220,0	177,4	50440	38919	57	52			2X1000	C	C	464,6	68	60	48	
BCML 1003 A	230,2	202,2	92539	73268	59	54			3X1000	D	C	589,7	52	60	48	
BCML 1003 B	285,8	243,9	88193	69179	59	54			3X1000	C	C	884,6	78	76	54	
BCML 1003 C	317,3	264,3	83921	65375	59	54			3X1000	C	C	1179,5	103	76	54	
BCML 1004 A	307,6	271,7	123347	97654	60	55			4X1000	D	C	784,8	69	76	54	
BCML 1004 B	384,3	329,2	117533	92186	60	55			4X1000	C	C	1177,2	103	76	54	
BCML 1004 C	427,8	357,2	111821	87102	60	55			4X1000	C	C	1569,6	138	88,9	60	
BCMQ 1001 A	66,9	52,7	19056	13706	40	33	P=860W I _n =4.2A n=430min ⁻¹	P=500W I _n =0.97A n=320min ⁻¹	1X1000	B	B	117,5	17	42	28	
BCMQ 1001 B	74,3	55,7	17431	12239	40	33			1X1000	B	A	176,3	26	42	28	
BCMQ 1001 C	74,3	54,4	15849	11104	40	33			1X1000	B	A	235	34	42	28	
BCMQ 1002 A	133,4	104,8	37982	27280	43	36			2X1000	B	B	232,3	34	54	42	
BCMQ 1002 B	148,0	110,3	34665	24325	43	36			2X1000	B	A	348,4	51	60	48	
BCMQ 1002 C	147,6	108,0	31462	22050	43	36			2X1000	B	A	464,6	68	60	48	
BCMQ 1003 A	181,0	148,9	60801	44789	45	38			3X1000	B	B	589,7	52	60	48	
BCMQ 1003 B	213,9	168,7	57267	41219	45	38			3X1000	B	A	884,6	78	76	54	
BCMQ 1003 C	228,9	176,6	54057	38170	45	38			3X1000	B	A	1179,5	103	76	54	
BCMQ 1004 A	244,1	201,7	81033	59684	46	39			4X1000	B	B	784,8	69	76	54	
BCMQ 1004 B	289,3	227,1	76313	54914	46	39			4X1000	B	A	1177,2	103	76	54	
BCMQ 1004 C	308,7	233,8	72018	50844	46	39			4X1000	B	A	1569,6	138	88,9	60	
BCMR 1001 A	61,4	43,6	16875	10747	38	29	P=670W I _n =1.4A n=390min ⁻¹	P=330W I _n =0.67A n=260min ⁻¹	1X1000	B	A	117,5	17	42	28	
BCMR 1001 B	66,9	45,6	15336	9649	38	29			1X1000	B	A	176,3	26	42	28	
BCMR 1002 A	133,3	90,1	30488	19176	41	32			2X1000	B	A	348,4	51	54	42	
BCMR 1002 B	167,9	125,5	53881	34895	43	34			2X1000	B	A	589,7	52	60	48	
BCMR 1003 A	209,3	145,0	47680	30076	43	34			3X1000	B	A	1179,5	103	60	48	
BCMR 1003 B	226,9	170,3	71810	46501	44	35			3X1000	B	A	784,8	69	76	54	
BCMR 1003 C	265,3	187,7	67581	43053	44	35			3X1000	B	A	1177,2	103	76	54	
BCMR 1004 A	279,3	192,3	63518	40064	44	35			4X1000	B	A	1569,6	138	76	54	
BCMR 1004 B	252,6	178,7	67581	43053	44	35			4X1000	B	A	1177,2	103,2	76	54	
BCMR 1004 C	266,0	183,1	63518	40064	44	35			4X1000	B	A	1569,6	137,6	88,9	60	

Nominal capacities according to standard ENV327(R404A Tair=25°C, Tcond=40°C, ΔTsubcool<3K, ΔTsuperheat=25K).

*See "General Contents" for more details.

**Energy Efficiency Class: see "General Contents" for more details.

BNM NH₃ - Single Fan Row

Product description

Application

The Alfa Laval condenser with stainless steel tubes was specifically designed for refrigeration plants where ammonia refrigerant is used. The condensers are designed for outdoor operation.

Standard design

Coil

The innovative heat exchanger gives excellent heat transfer performance, thanks to the new fin pattern and surface corrugation developed by Alfa Laval, combined with smooth stainless steel tubes (304L).

Casing

The BNM are manufactured with the AlfaBlue design profile providing sturdy construction, higher rigidity with less weight, and safer transport. The standard model has a high corrosion resistance as the casework is made with galvanized steel sheets painted in RAL 9002 (corrosion resistance C4). Supports manufactured in galvanized steel, with optimized length to permit uniform air suction in the coil.

Benefits

- Footprint: optimized footprint with higher capacity
- 630, 800, 910, 1000 mm fan:
 - More performance available
 - Low power consumption fan motor
 - More options on noise levels
 - Flexible design
- RAL 9002 all parts painted:
 - No cut edges
 - Higher corrosion resistance, double surface treatment
 - External Corrosion Class C4
- Coil design: increased heat transfer thanks to innovative fin corrugations
- Casing: strong casing with new design
- High Energy Efficiency: best performance with low energy consumption

Options

- Non-standard fin spacing: for heavy dusty environment
- Multi-circuits: total capacity split in multiple compressor lines
- Coil treatment: corrosion resistance, ideal for aggressive environments
- Vibration Dampers: for reducing vibrations
- Electrical parts:
 - Switch on/off: local safety switch wired to isolate the fan and also the switch EMC type
 - Terminal Box: all fans wired for an easy electrical connection
 - Switchboard
- Cabling: ready to install
- Frequency Converter design: units can run under frequency control (when air temperature is below the design, it allows energy saving, noise reduction and longer fan motor life)



- Fan Step Control:
 - Energy saving
 - Cheapest method of controlling performance
- Fan Speed Control:
 - Energy saving
 - Noise reduction when the air temperature is below the design temperature.
 - Variable and efficient speed control according to the heat rejected
 - Better performance control
- Special fans:
 - 480/3ph-60Hz IP54: High adaptability for every market
 - IP 55: High protection fan for use in tropical or desert areas
 - High temperature Electric Motors: for use when the air temperature is higher than permitted for the use of standard fans.

Fans

Four different fan diameters are available for the BCM: 630, 800, 910, 1000 mm. Diameter 630, 800, 910, 1000 mm with three-phase motor 400V-50Hz, for 630 (L, Q, R) also single-phase 230V-50Hz. The motors come with external rotors, protection class IP 54 according to DIN 40050. This Axial Condenser BCM is available in five noise levels: (S) standard, (L) low, (Q) quiet, (R) residential and the new (T) high performance fan. The motors are fitted with a thermal contact. The fans are suitable for operation in air temp. application between -40°C and +40°C.

For air temperature lower than +20°C, the full load current (FLC) can be calculated by using the correction factor table. The overload protectors should have a 20% margin to accommodate fan motor supplier variations.

T [°C]	20	10	0	-10	-15	-20	-25	-30
Fc	1	1,04	1,08	1,12	1,14	1,16	1,18	1,2

Model	Capacity [kW]		Airflow [m ³ /h]		Lp [dB(A)]*		Motor (3/400V- 50Hz)		Fans	Surface	Tube volume	Conn. Size	
	Δ	Y	Δ	Y	Δ	Y	Δ	Y	N° x D [mm]	m ²	dm ³	mm	
													Inlet
Ø 630													
BNMS631A	50,6	43,6	17525	13463	56	50	P=2600W I=4.8A n=1310min-1	P=1600W I=2.7A n=1000min-1	1 x 630	75,9	12	1" 1/2	1"
BNMS631B	63,3	52,7	16814	12772	56	50			1 x 630	113,8	18	1" 1/2	1"
BNMS631C	70,0	56,7	16082	12119	56	50			1 x 630	151,8	24	1" 1/2	1"
BNMS632A	97,9	84,7	34947	26819	59	53			2 x 630	148,5	24	1" 1/2	1"
BNMS632B	123,7	103,3	33459	25389	59	53			2 x 630	222,7	35	1" 1/2	1"
BNMS632C	136,0	110,6	31943	24049	59	53			2 x 630	296,9	47	1" 1/2	1"
BNMS633A	148,6	128,2	52366	40173	61	55			3 x 630	221	35	2"	1"
BNMS633B	186,0	155,1	50101	38004	61	55			3 x 630	331,6	53	2"	1"
BNMS633C	206,2	167,2	47801	35976	61	55			3 x 630	442,1	70	2"	1"
BNMS634A	195,0	168,8	69785	53526	62	56			4 x 630	293,6	47	2"	1"
BNMS634B	245,0	204,8	66742	50618	62	56	4 x 630	440,4	70	2"	1"		
BNMS634C	271,0	220,4	63658	47902	62	56	4 x 630	587,2	93	2"	1"		
BNML631A	33,8	29,9	9667	8043	45	40	P=690W I=1.25A n=900min-1	P=480W I=0.78A n=690min-1	1 x 630	75,9	12	1" 1/2	1"
BNML631B	40,0	34,3	9337	7667	45	40			1 x 630	113,8	18	1" 1/2	1"
BNML631C	42,6	35,6	9016	7319	45	40			1 x 630	151,8	24	1" 1/2	1"
BNML632A	66,2	58,7	19283	16027	48	43			2 x 630	148,5	24	1" 1/2	1"
BNML632B	78,8	67,7	18600	15252	48	43			2 x 630	222,7	35	1" 1/2	1"
BNML632C	83,7	70,2	17937	14537	48	43			2 x 630	296,9	47	1" 1/2	1"
BNML633A	99,8	88,4	28899	24010	50	45			3 x 630	221	35	2"	1"
BNML633B	118,3	101,5	27861	22835	50	45			3 x 630	331,6	53	2"	1"
BNML633C	126,1	105,5	26856	21754	50	45			3 x 630	442,1	70	2"	1"
BNML634A	131,9	116,9	38514	31992	51	46			4 x 630	293,6	47	2"	1"
BNML634B	156,6	134,6	37122	30418	51	46	4 x 630	440,4	70	2"	1"		
BNML634C	166,8	139,8	35775	28970	51	46	4 x 630	587,2	93	2"	1"		
BNMQ631A	28,6	24,4	7004	5651	38	31	P=330W I=0.80A n=650min-1	P=190W I=0.38A n=480min-1	1 x 630	75,9	12	1" 1/2	1"
BNMQ631B	32,5	26,8	6730	5345	38	31			1 x 630	113,8	18	1" 1/2	1"
BNMQ631C	33,6	26,9	6468	5070	38	31			1 x 630	151,8	24	1" 1/2	1"
BNMQ632A	56,1	48,1	13965	11253	41	34			2 x 630	148,5	24	1" 1/2	1"
BNMQ632B	64,1	52,9	13398	10624	41	34			2 x 630	222,7	35	1" 1/2	1"
BNMQ632C	65,8	52,9	12860	10060	41	34			2 x 630	296,9	47	1" 1/2	1"
BNMQ633A	82,2	70,7	20926	16854	43	36			3 x 630	221	35	1" 1/2	1"
BNMQ633B	94,9	78,6	20065	15901	43	36			3 x 630	331,6	53	1" 1/2	1"
BNMQ633C	98,5	79,2	19250	15050	43	36			3 x 630	442,1	70	1" 1/2	1"
BNMQ634A	111,1	95,3	27886	22455	44	37			4 x 630	293,6	47	1" 1/2	1"
BNMQ634B	124,2	103,2	26732	21179	44	37	4 x 630	440,4	70	1" 1/2	1"		
BNMQ634C	128,9	104,1	25640	20040	44	37	4 x 630	587,2	93	1" 1/2	1"		
BNMR631A	20,9	17,4	4597	3662	28	22	P=125W I=0.33A n=430min-1	P=85W I=0.14A n=330min-1	1 x 630	75,9	12	1" 1/2	1"
BNMR631B	22,6	18,2	4401	3458	28	22			1 x 630	113,8	18	1" 1/2	1"
BNMR631C	22,7	17,8	4211	3272	28	22			1 x 630	151,8	24	1" 1/2	1"
BNMR632A	34,4	34,4	7293	7293	25	25			2 x 630	148,5	24	1" 1/2	1"
BNMR632B	44,8	36,1	8759	6871	31	25			2 x 630	222,7	35	1" 1/2	1"
BNMR632C	44,7	35,2	8366	6490	31	25			2 x 630	296,9	47	1" 1/2	1"
BNMR633A	60,9	51,0	13730	10922	33	27			3 x 630	221	35	1" 1/2	1"
BNMR633B	66,7	53,8	13115	10284	33	27			3 x 630	331,6	53	1" 1/2	1"
BNMR633C	66,9	52,6	12520	9708	33	27			3 x 630	442,1	70	1" 1/2	1"
BNMR634A	81,8	68,3	18297	14551	34	28			4 x 630	293,6	47	1" 1/2	1"
BNMR634B	87,9	71,1	17471	13696	34	28	4 x 630	440,4	70	1" 1/2	1"		
BNMR634C	88,2	69,6	16673	12926	34	28	4 x 630	587,2	93	1" 1/2	1"		

Nominal capacities according to R717 Tair=25°C, Tcond=40°C, ΔTsubcool<3K, ΔTsuperheat=25K).

Note: The units are designed for horizontal installation. Vertical installations require special refrigerant circuits.

*See the "General Contents" for more details.

Model	Capacity [kW]		Airflow [m ³ /h]		Lp [dB(A)]*		Motor (3/400V-50Hz)		Fans	Surface	Tube volume	Conn. Size	
	Δ	Y	Δ	Y	Δ	Y	Δ	Y	N° x D [mm]	m ²	dm ³	mm	
													Inlet
Ø 630 LONG													
BNMS631AL	56,8	48,8	17948	13922	56	50	P=2600W I=4.8 n=1310min-1	P=1600W I=2.7 n=1000min-1	1 x 630	96,5	15	1" 1/2	1"
BNMS631BL	70,5	58,6	17527	13464	56	50			1 x 630	144,8	23	1" 1/2	1"
BNMS631CL	77,4	62,7	17059	13002	56	50			1 x 630	193,1	31	1" 1/2	1"
BNMS632AL	108,7	94,2	35849	27790	59	53			2 x 630	189,7	30	2"	1"
BNMS632BL	137,2	114,6	34973	26845	59	53			2 x 630	284,6	45	2"	1"
BNMS632CL	149,5	122,2	34002	25894	59	53			2 x 630	379,5	60	2"	1"
BNMS633AL	166,8	143,6	53750	41657	61	55			3 x 630	283	45	2"	1"
BNMS633BL	207,4	172,8	52417	40225	61	55			3 x 630	424,4	68	2"	1"
BNMS633CL	229,0	185,8	50943	38785	61	55	3 x 630	565,9	90	2"	1"		
BNML631AL	37,1	32,9	9886	8304	45	40	P=690W I=1.25A n=900min-1	P=480W I=0.78A n=690min-1	1 x 630	96,5	15	1" 1/2	1"
BNML631BL	43,3	37,4	9668	8044	45	40			1 x 630	144,8	23	1" 1/2	1"
BNML631CL	45,8	38,7	9448	7791	45	40			1 x 630	193,1	31	1" 1/2	1"
BNML632AL	72,4	64,2	19747	16577	48	43			2 x 630	189,7	30	2"	1"
BNML632BL	85,3	73,7	19296	16041	48	43			2 x 630	284,6	45	2"	1"
BNML632CL	89,9	76,1	18843	15523	48	43			2 x 630	379,5	60	2"	1"
BNML633AL	109,8	97,2	29607	24850	50	45			3 x 630	283	45	2"	1"
BNML633BL	128,5	110,8	28923	24038	50	45			3 x 630	424,4	68	2"	1"
BNML633CL	136,1	114,9	28238	23254	50	45	3 x 630	565,9	90	2"	1"		
BNMQ631AL	31,1	26,6	7190	5870	38	31	P=330W I=0.80A n=650min-1	P=190W I=0.38A n=480min-1	1 x 630	96,5	15	1" 1/2	1"
BNMQ631BL	34,9	29,0	7004	5652	38	31			1 x 630	144,8	23	1" 1/2	1"
BNMQ631CL	36,0	29,2	6821	5444	38	31			1 x 630	193,1	31	1" 1/2	1"
BNMQ632AL	60,9	52,3	14358	11714	41	34			2 x 630	189,7	30	1" 1/2	1"
BNMQ632BL	69,1	57,4	13976	11265	41	34			2 x 630	284,6	45	1" 1/2	1"
BNMQ632CL	70,3	57,4	13598	10841	41	34			2 x 630	379,5	60	1" 1/2	1"
BNMQ633AL	88,3	76,5	21526	17557	43	36			3 x 630	283	45	1" 1/2	1"
BNMQ633BL	101,8	85,0	20947	16878	43	36			3 x 630	424,4	68	1" 1/2	1"
BNMQ633CL	105,4	86,0	20375	16237	43	36	3 x 630	565,9	90	1" 1/2	1"		
BNMR631AL	22,4	18,7	4724	3806	28	22	P=125W I=0.33A n=430min-1	P=85 I=0.14A n=330min-1	1 x 630	96,5	15	1" 1/2	1"
BNMR631BL	24,1	19,6	4597	3663	28	22			1 x 630	144,8	23	1" 1/2	1"
BNMR631CL	24,2	19,3	4467	3525	28	22			1 x 630	193,1	31	1" 1/2	1"
BNMR632AL	44,2	37,0	9433	7594	31	25			2 x 630	189,7	30	1" 1/2	1"
BNMR632BL	47,9	38,9	9171	7301	31	25			2 x 630	284,6	45	1" 1/2	1"
BNMR632CL	47,8	38,2	8903	7018	31	25			2 x 630	379,5	60	1" 1/2	1"
BNMR633AL	64,9	54,6	14142	11383	33	27			3 x 630	283	45	1" 1/2	1"
BNMR633BL	71,1	57,8	13745	10938	33	27			3 x 630	424,4	68	1" 1/2	1"
BNMR633CL	71,6	57,1	13339	10510	33	27	3 x 630	565,9	90	1" 1/2	1"		

Nominal capacities according to R717 Tair=25°C, Tcond=40°C, ΔTsubcool<3K, ΔTsuperheat=25K).

Note: The units are designed for horizontal installation. Vertical installations require special refrigerant circuits.

*See the "General Contents" for more details.

Model	Capacity [kW]		Airflow [m³/h]		Lp [dB(A)]*		Motor (3/400V-50Hz)		Fans	Surface	Tube volume	Conn. Size	
	Δ	Y	Δ	Y	Δ	Y	Δ	Y	N° x D [mm]	m²	dm³	mm	
													Inlet
Ø 800													
BNMS801A	75	64	22049	17348	51	46	P=2000W I=4A n=880min-1	P=1250 I=2,3A n=680min-1	1 x 800	143,8	23	1" 1/2	1"
BNMS801B	88	74	21295	16575	51	46			1 x 800	215,7	34	1" 1/2	1"
BNMS801C	96	78	20562	15849	51	46			1 x 800	287,6	46	1" 1/2	1"
BNMS802A	149	128	44025	34620	54	49			2 x 800	283,6	45	2"	1"
BNMS802B	176	147	42483	33042	54	49			2 x 800	425,4	68	2"	1"
BNMS802C	192	156	40987	31564	54	49			2 x 800	567,2	90	2"	1"
BNMS803A	216	187	66000	51891	56	51			3 x 800	423,4	67	2" 1/2	1" 1/2
BNMS803B	263	220	63670	49508	56	51			3 x 800	635,1	101	2" 1/2	1" 1/2
BNMS803C	287	233	61411	47279	56	51			3 x 800	846,9	135	2" 1/2	1" 1/2
BNMS804A	297	255	87975	69163	57	52			4 x 800	563,2	90	3"	2"
BNMS804B	359	298	84857	65973	57	52			4 x 800	844,9	134	3"	2"
BNMS804C	386	312	81834	62993	57	52			4 x 800	1126,5	179	3"	2"
BNMS805A	366	316	109950	86434	58	53			5 x 800	703,1	112	3"	2"
BNMS805B	444	370	106043	82438	58	53			5 x 800	1054,6	168	3"	2"
BNMS805C	475	386	102257	78707	58	53			5 x 800	1406,1	224	3"	2"
BNML801A	60	53	16965	13965	44	40	P=1050W I=2,4A n=680min-1	P=770W I=1,5A n=530min-1	1 x 800	143,8	23	1" 1/2	1"
BNML801B	70	59	16404	13325	44	40			1 x 800	215,7	34	1" 1/2	1"
BNML801C	74	62	15851	12732	44	40			1 x 800	287,6	46	1" 1/2	1"
BNML802A	120	105	33877	27868	47	43			2 x 800	283,6	45	2"	1"
BNML802B	139	119	32728	26562	47	43			2 x 800	425,4	68	2"	1"
BNML802C	148	123	31597	25356	47	43			2 x 800	567,2	90	2"	1"
BNML803A	176	155	50788	41769	49	45			3 x 800	423,4	67	2" 1/2	1" 1/2
BNML803B	208	178	49052	39798	49	45			3 x 800	635,1	101	2" 1/2	1" 1/2
BNML803C	222	185	47342	37978	49	45			3 x 800	846,9	135	2" 1/2	1" 1/2
BNML804A	240	210	67698	55670	50	46			4 x 800	563,2	90	3"	2"
BNML804B	282	240	65374	53034	50	46			4 x 800	844,9	134	3"	2"
BNML804C	298	247	63087	50601	50	46			4 x 800	1126,5	179	3"	2"
BNML805A	297	261	84609	69572	51	47			5 x 800	703,1	112	3"	2"
BNML805B	350	298	81697	66269	51	47			5 x 800	1054,6	168	3"	2"
BNML805C	368	306	78832	63223	51	47			5 x 800	1406,1	224	3"	2"
BNMQ801A	45	37	10539	8229	35	28	P=370W I=1,2A n=440min-1	P=200W I=0,5A n=340min-1	1 x 800	143,8	23	1" 1/2	1"
BNMQ801B	50	40	10126	7803	35	28			1 x 800	215,7	34	1" 1/2	1"
BNMQ801C	51	40	9724	7420	35	28			1 x 800	287,6	46	1" 1/2	1"
BNMQ802A	89	74	21038	16416	38	31			2 x 800	283,6	45	1" 1/2	1"
BNMQ802B	100	80	20193	15547	38	31			2 x 800	425,4	68	1" 1/2	1"
BNMQ802C	101	79	19372	14772	38	31			2 x 800	567,2	90	1" 1/2	1"
BNMQ803A	134	111	31537	24602	40	33			3 x 800	423,4	67	2"	1"
BNMQ803B	145	117	30259	23292	40	33			3 x 800	635,1	101	2"	1"
BNMQ803C	151	118	29020	22123	40	33			3 x 800	846,9	135	2"	1"
BNMQ804A	179	149	42036	32787	41	34			4 x 800	563,2	90	2"	1"
BNMQ804B	196	157	40325	31036	41	34			4 x 800	844,9	134	2"	1"
BNMQ804C	197	155	38668	29474	41	34			4 x 800	1126,5	179	2"	1"
BNMQ805A	221	184	52535	40973	42	35			5 x 800	703,1	112	2" 1/2	1" 1/2
BNMQ805B	239	193	50391	38780	42	35			5 x 800	1054,6	168	2" 1/2	1" 1/2
BNMQ805C	247	194	48316	36825	42	35			5 x 800	1406,1	224	2" 1/2	1" 1/2
BNMR801A	40	28	9043	5730	31	20	P=250W I=0,62A n=380min-1	P=110W I=0,27A n=240min-1	1 x 800	143,8	23	1" 1/2	1"
BNMR801B	44	29	8637	5393	31	20			1 x 800	215,7	34	1" 1/2	1"
BNMR801C	44	28	8255	5093	31	20			1 x 800	287,6	46	1" 1/2	1"
BNMR802A	80	55	18046	11426	34	23			2 x 800	283,6	45	1" 1/2	1"
BNMR802B	87	57	17216	10741	34	23			2 x 800	425,4	68	1" 1/2	1"
BNMR802C	87	55	16441	10132	34	23			2 x 800	567,2	90	1" 1/2	1"
BNMR803A	119	83	27049	17122	36	25			3 x 800	423,4	67	2"	1"
BNMR803B	128	85	25796	16089	36	25			3 x 800	635,1	101	2"	1"
BNMR803C	130	83	24625	15171	36	25			3 x 800	846,9	135	2"	1"
BNMR804A	160	111	36052	22818	37	26			4 x 800	563,2	90	2"	1"
BNMR804B	172	113	34375	21436	37	26			4 x 800	844,9	134	2"	1"
BNMR804C	170	109	32810	20210	37	26			4 x 800	1126,5	179	2"	1"
BNMR805A	198	138	45054	28514	38	27			5 x 800	703,1	112	2" 1/2	1" 1/2
BNMR805B	210	140	42954	26783	38	27			5 x 800	1054,6	168	2" 1/2	1" 1/2
BNMR805C	214	137	40995	25248	38	27			5 x 800	1406,1	224	2" 1/2	1" 1/2

Nominal capacities according to R717 Tair=25°C, Tcond=40°C, ΔTsubcool<3K, ΔTsuperheat=25K).

Note: The units are designed for horizontal installation. Vertical installations require special refrigerant circuits.

*See the "General Contents" for more details.

Model	Capacity [kW]		Airflow [m³/h]		Lp [dB(A)]*		Motor (3/400V-50Hz)		Fans	Surface	Tube volume	Conn. Size	
	Δ	Y	Δ	Y	Δ	Y	Δ	Y	N° x D [mm]	m²	dm³	mm	
													Inlet
Ø 900													
BNMT901A	100,9	90,5	32213	26761	55	50	P=3600W I=7,2 n=890min-1	P=2500W I=4,3 n=700min-1	1 x 910	171,8	27	1" 1/2	1"
BNMT901B	125,2	109,1	31428	25747	55	50			1 x 910	257,7	41	1" 1/2	1"
BNMT901C	137,3	117,0	30497	24695	55	50			1 x 910	343,5	55	1" 1/2	1"
BNMT902A	197,5	177,6	64371	53445	58	53			2 x 910	339,5	54	2" 1/2	1"1/2
BNMT902B	246,3	215,1	62750	51368	58	53			2 x 910	509,3	81	2" 1/2	1"1/2
BNMT902C	273,8	233,1	60838	49224	58	53			2 x 910	679,1	108	2" 1/2	1"1/2
BNMT903A	300,9	269,8	96529	80128	60	55			3 x 910	507,3	81	3"	2"
BNMT903B	373,5	325,5	94072	76987	60	55			3 x 910	761	121	3"	2"
BNMT903C	410,3	349,1	91177	73752	60	55			3 x 910	1014,6	162	3"	2"
BNMT904A	394,4	354,7	128686	106811	61	56			4 x 910	675,1	107	3"	2"
BNMT904B	491,8	429,4	125392	102607	61	56	4 x 910	1012,6	161	3"	2"		
BNMT904C	546,7	465,2	121515	98279	61	56	4 x 910	1350,2	215	3"	2"		
BNMS901A	80,6	69,2	22672	17906	53	48	P=1650W I=3,5 n=860min-1	P=1000W I=1,8 n=660min-1	1 x 910	171,8	27	1" 1/2	1"
BNMS901B	93,3	78,5	22076	17304	53	48			1 x 910	257,7	41	1" 1/2	1"
BNMS901C	102,0	83,3	21464	16708	53	48			1 x 910	343,5	55	1" 1/2	1"
BNMS902A	160,8	138,0	45297	35764	56	51			2 x 910	339,5	54	2"	1"
BNMS902B	192,9	160,5	44079	34537	56	51			2 x 910	509,3	81	2"	1"
BNMS902C	205,6	167,4	42830	33323	56	51			2 x 910	679,1	108	2"	1"
BNMS903A	240,9	206,8	67922	53622	58	53			3 x 910	507,3	81	2" 1/2	1" 1/2
BNMS903B	280,0	235,0	66081	51768	58	53			3 x 910	761	121	2" 1/2	1" 1/2
BNMS903C	305,6	249,2	64195	49937	58	53			3 x 910	1014,6	162	2" 1/2	1" 1/2
BNMS904A	321,0	275,5	90547	71479	59	54			4 x 910	675,1	107	3"	2"
BNMS904B	385,1	320,4	88083	69000	59	54	4 x 910	1012,6	161	3"	2"		
BNMS904C	410,9	334,4	85560	66551	59	54	4 x 910	1350,2	215	3"	2"		
BNML901A	63,3	49,7	16865	12006	46	39	P=900W I=2,2 n=640min-1	P=470W I=1,05A n=440min-1	1 x 910	171,8	27	1" 1/2	1"
BNML901B	71,6	54,0	16358	11474	46	39			1 x 910	257,7	41	1" 1/2	1"
BNML901C	75,9	55,1	15870	11001	46	39			1 x 910	343,5	55	1" 1/2	1"
BNML902A	126,2	99,1	33689	23966	49	42			2 x 910	339,5	54	2"	1"
BNML902B	146,3	109,2	32657	22887	49	42			2 x 910	509,3	81	2"	1"
BNML902C	152,7	110,3	31665	21932	49	42			2 x 910	679,1	108	2"	1"
BNML903A	189,2	148,4	50513	35927	51	44			3 x 910	507,3	81	2" 1/2	1" 1/2
BNML903B	214,6	161,5	48955	34301	51	44			3 x 910	761	121	2" 1/2	1" 1/2
BNML903C	227,4	164,7	47459	32862	51	44			3 x 910	1014,6	162	2" 1/2	1" 1/2
BNML904A	252,1	197,8	67336	47887	52	45			4 x 910	675,1	107	3"	2"
BNML904B	292,1	218,1	65253	45714	52	45	4 x 910	1012,6	161	3"	2"		
BNML904C	305,0	220,3	63252	43792	52	45	4 x 910	1350,2	215	3"	2"		
BNMQ901A	47,9	40,5	11010	8818	36	30	P=330W I=0,83A n=440min-1	P=185W I=0,38A n=330min-1	1 x 910	171,8	27	1" 1/2	1"
BNMQ901B	53,3	43,5	10653	8437	36	30			1 x 910	257,7	41	1" 1/2	1"
BNMQ901C	54,5	43,5	10305	8084	36	30			1 x 910	343,5	55	1" 1/2	1"
BNMQ902A	95,7	80,8	21992	17604	39	33			2 x 910	339,5	54	1" 1/2	1"
BNMQ902B	106,3	86,8	21264	16830	39	33			2 x 910	509,3	81	1" 1/2	1"
BNMQ902C	107,1	85,9	20556	16115	39	33			2 x 910	679,1	108	1" 1/2	1"
BNMQ903A	143,3	121,1	32973	26390	41	35			3 x 910	507,3	81	2"	1"
BNMQ903B	153,6	126,6	31875	25223	41	35			3 x 910	761	121	2"	1"
BNMQ903C	160,7	128,7	30806	24145	41	35			3 x 910	1014,6	162	2"	1"
BNMQ904A	192,6	162,3	43954	35176	42	36			4 x 910	675,1	107	2"	1"
BNMQ904B	207,8	170,8	42485	33616	42	36	4 x 910	1012,6	161	2"	1"		
BNMQ904C	214,2	171,5	41056	32176	42	36	4 x 910	1350,2	215	2"	1"		
BNMR901A	45,5	32,4	10290	6691	35	25	P=270W I=0,70A n=390min-1	P=140W I=0,32A n=250min-1	1 x 910	171,8	27	1" 1/2	1"
BNMR901B	50,2	33,7	9934	6366	35	25			1 x 910	257,7	41	1" 1/2	1"
BNMR901C	51,0	33,1	9591	6077	35	25			1 x 910	343,5	55	1" 1/2	1"
BNMR902A	90,9	64,7	20552	13354	38	28			2 x 910	339,5	54	1" 1/2	1"
BNMR902B	100,2	67,3	19826	12696	38	28			2 x 910	509,3	81	1" 1/2	1"
BNMR902C	100,4	65,6	19129	12110	38	28			2 x 910	679,1	108	1" 1/2	1"
BNMR903A	136,3	97,0	30813	20017	40	30			3 x 910	507,3	81	2"	1"
BNMR903B	145,2	99,1	29717	19025	40	30			3 x 910	761	121	2"	1"
BNMR903C	150,6	98,3	28666	18143	40	30			3 x 910	1014,6	162	2"	1"
BNMR904A	183,0	129,8	41074	26680	41	31			4 x 910	675,1	107	2"	1"
BNMR904B	196,2	133,1	39609	25355	41	31	4 x 910	1012,6	161	2"	1"		
BNMR904C	200,7	131,0	38203	24175	41	31	4 x 910	1350,2	215	2"	1"		

Nominal capacities according to R717 Tair=25°C, Tcond=40°C, ΔTsubcool<3K, ΔTsuperheat=25K).

Note: The units are designed for horizontal installation. Vertical installations require special refrigerant circuits.

*See the "General Contents" for more details.

Model	Capacity [kW]		Airflow [m ³ /h]		Lp [dB(A)]*		Motor (3/400V-50Hz)		Fans	Surface	Tube volume	Conn. Size	
	Δ	Υ	Δ	Υ	Δ	Υ	Δ	Υ	N° x D [mm]	m ²	dm ³	mm	
												Inlet	Outlet
Ø 1000													
BNML1001A	91,2	79,4	30352	23947	54	49	P=2200W I=4,2A n=670min ⁻¹	P=1500W, I=2,7A n=530min ⁻¹	1 x 1000	171,8	27	1" 1/2	1"
BNML1001B	112,0	93,9	28653	22390	54	49			1 x 1000	257,7	41	1" 1/2	1"
BNML1001C	119,5	97,8	27045	20991	54	49			1 x 1000	343,5	55	1" 1/2	1"
BNML1002A	181,8	158,2	60569	47766	57	52			2 x 1000	339,5	54	2" 1/2	1"1/2
BNML1002B	220,3	185,3	57106	44602	57	52			2 x 1000	509,3	81	2" 1/2	1"1/2
BNML1002C	240,4	196,1	53847	41775	57	52			2 x 1000	679,1	108	2" 1/2	1"1/2
BNML1003A	276,6	239,8	90783	71583	59	54			3 x 1000	507,3	81	3"	2"
BNML1003B	333,6	279,8	85558	66814	59	54			3 x 1000	761	121	3"	2"
BNML1003C	356,3	291,4	80646	62556	59	54			3 x 1000	1014,6	162	3"	2"
BNML1004A	362,9	315,7	120998	95400	60	55			4 x 1000	675,1	107	3"	2"
BNML1004B	439,8	369,7	114009	89024	60	55	4 x 1000	1012,6	161	3"	2"		
BNML1004C	466,5	383,2	107445	83338	60	55	4 x 1000	1350,2	215	3"	2"		
BNMQ1001A	74,1	59,9	19832	14501	40	33	P=860W I=2A n=430min ⁻¹	P=500W I=0,97A n=320min ⁻¹	1 x 1000	171,8	27	1" 1/2	1"
BNMQ1001B	82,5	63,5	18536	13193	40	33			1 x 1000	257,7	41	1" 1/2	1"
BNMQ1001C	85,6	63,1	17276	12119	40	33			1 x 1000	343,5	55	1" 1/2	1"
BNMQ1002A	147,5	119,1	39553	28889	43	36			2 x 1000	339,5	54	2"	1"
BNMQ1002B	164,7	126,5	36922	26245	43	36			2 x 1000	509,3	81	2"	1"
BNMQ1002C	171,7	126,1	34351	24084	43	36			2 x 1000	679,1	108	2"	1"
BNMQ1003A	221,0	178,4	59272	43276	45	38			3 x 1000	507,3	81	2" 1/2	1"1/2
BNMQ1003B	246,8	189,5	55307	39296	45	38			3 x 1000	761	121	2" 1/2	1"1/2
BNMQ1003C	255,3	188,0	51423	36048	45	38			3 x 1000	1014,6	162	2" 1/2	1"1/2
BNMQ1004A	287,9	234,2	78991	57663	46	39			4 x 1000	675,1	107	2" 1/2	1"1/2
BNMQ1004B	337,1	256,6	73691	52346	46	39	4 x 1000	1012,6	161	2" 1/2	1"1/2		
BNMQ1004C	342,6	251,4	68495	48013	46	39	4 x 1000	1350,2	215	2" 1/2	1"1/2		
BNMR1001A	68,4	49,9	17579	11315	38	29	P=670W I=1,4A n=390min ⁻¹	P=330W I=0,67A n=260min ⁻¹	1 x 1000	171,8	27	1" 1/2	1"
BNMR1001B	75,3	52,1	16386	10376	38	29			1 x 1000	257,7	41	1" 1/2	1"
BNMR1001C	77,6	51,3	15191	9553	38	29			1 x 1000	343,5	55	1" 1/2	1"
BNMR1002A	136,2	99,4	35058	22548	41	32			2 x 1000	339,5	54	2"	1"
BNMR1002B	150,2	103,7	32629	20649	41	32			2 x 1000	509,3	81	2"	1"
BNMR1002C	153,9	101,4	30193	18983	41	32			2 x 1000	679,1	108	2"	1"
BNMR1003A	203,9	148,8	52536	33781	43	34			3 x 1000	507,3	81	2" 1/2	1"1/2
BNMR1003B	225,1	155,3	48871	30921	43	34			3 x 1000	761	121	2" 1/2	1"1/2
BNMR1003C	229,0	151,4	45193	28411	43	34			3 x 1000	1014,6	162	2" 1/2	1"1/2
BNMR1004A	266,6	196,0	70014	45013	44	35			4 x 1000	675,1	107	2" 1/2	1"1/2
BNMR1004B	306,2	209,4	65112	41192	44	35	4 x 1000	1012,6	161	2" 1/2	1"1/2		
BNMR1004C	306,9	202,2	60192	37840	44	35	4 x 1000	1350,2	215	2" 1/2	1"1/2		

Nominal capacities according to R717 T_{air}=25°C, T_{cond}=40°C, ΔT_{subcool}<3K, ΔT_{superheat}=25K).

Note: The units are designed for horizontal installation. Vertical installations require special refrigerant circuits.

*See the "General Contents" for more details.

BCM/BNM - Single Fan Row

Drawings

Model	Weight [kg]	Dimensions (mm)					N° feet	
		A	B	C	D	G	V	H
Ø 630								
BCM_631 A	110	1475	1525	1065(V)/944(H)	-	1255(V)/1220(H)	2	4
BCM_631 B	120	1475	1525	1065(V)/944(H)	-	1255(V)/1220(H)	2	4
BCM_631 C	130	1475	1525	1065(V)/944(H)	-	1255(V)/1220(H)	2	4
BCM_632 A	220	2565	2615	2155(V)/2084(H)	-	1255(V)/1220(H)	2	4
BCM_632 B	240	2565	2615	2155(V)/2084(H)	-	1255(V)/1220(H)	2	4
BCM_632 C	260	2565	2615	2155(V)/2084(H)	-	1255(V)/1220(H)	2	4
BCM_633 A	340	3655	3705	3245(V)/3174(H)	-	1255(V)/1220(H)	2	4
BCM_633 B	365	3655	3705	3245(V)/3174(H)	-	1255(V)/1220(H)	2	4
BCM_633 C	390	3655	3705	3245(V)/3174(H)	-	1255(V)/1220(H)	2	4
BCM_634 A	450	4745	4795	2155(V)/2084(H)	2180	1255(V)/1220(H)	3	6
BCM_634 B	485	4745	4795	2155(V)/2084(H)	2180	1255(V)/1220(H)	3	6
BCM_634 C	520	4745	4795	2155(V)/2084(H)	2180	1255(V)/1220(H)	3	6
Ø 630 LONG								
BCM_631 AL	140	1785	1835	1375(V)/1304(H)	-	1255(V)/1220(H)	2	4
BCM_631 BL	155	1785	1835	1375(V)/1304(H)	-	1255(V)/1220(H)	2	4
BCM_631 CL	170	1785	1835	1375(V)/1304(H)	-	1255(V)/1220(H)	2	4
BCM_632 AL	285	3185	3235	2775(V)/2104(H)	-	1255(V)/1220(H)	2	4
BCM_632 BL	310	3185	3235	2775(V)/2104(H)	-	1255(V)/1220(H)	2	4
BCM_632 CL	335	3185	3235	2775(V)/2104(H)	-	1255(V)/1220(H)	2	4
BCM_633 AL	440	4585	4635	4175(V)/4104(H)	-	1255(V)/1220(H)	2	4
BCM_633 BL	470	4585	4635	4175(V)/4104(H)	-	1255(V)/1220(H)	2	4
BCM_633 CL	500	4585	4635	4175(V)/4104(H)	-	1255(V)/1220(H)	2	4
Ø 800								
BCM_801 A	175	2135	2185	1725(V)/1664(H)	-	1495(V)/1250(H)	2	4
BCM_801 B	195	2135	2185	1725(V)/1664(H)	-	1495(V)/1250(H)	2	4
BCM_801 C	215	2135	2185	1725(V)/1664(H)	-	1495(V)/1250(H)	2	4
BCM_802 A	350	3885	3935	3475(V)/3404(H)	-	1495(V)/1250(H)	2	4
BCM_802 B	390	3885	3935	3475(V)/3404(H)	-	1495(V)/1250(H)	2	4
BCM_802 C	430	3885	3935	3475(V)/3404(H)	-	1495(V)/1250(H)	2	4
BCM_803 A	540	5635	5685	5225(V)/5154(H)	-	1495(V)/1250(H)	2	4
BCM_803 B	600	5635	5685	5225(V)/5154(H)	-	1495(V)/1250(H)	2	4
BCM_803 C	660	5635	5685	5225(V)/5154(H)	-	1495(V)/1250(H)	2	4
BCM_804 A	720	7385	7435	3475(V)/3404(H)	3500	1495(V)/1250(H)	3	6
BCM_804 B	800	7385	7435	3475(V)/3404(H)	3500	1495(V)/1250(H)	3	6
BCM_804 C	880	7385	7435	3475(V)/3404(H)	3500	1495(V)/1250(H)	3	6
BCM_805 A	900	9135	9185	3475(V)/3404(H)	1775(V)/1846(H)	1495(V)/1250(H)	4	8
BCM_805 B	1000	9135	9185	3475(V)/3404(H)	1775(V)/1846(H)	1495(V)/1250(H)	4	8
BCM_805 C	1100	9135	9185	3475(V)/3404(H)	1775(V)/1846(H)	1495(V)/1250(H)	4	8

Standard feet 500 mm.

We reserve the right to change our technical data without prior notice.

Model	Weight [kg]	Dimensions (mm)					N° feet	
		A	B	C	D	G	V	H
Ø 910								
BCM_901 A	210	2485	2535	2075(V)/2004(H)	-	1495(V)/1290(H)	2	4
BCM_901 B	235	2485	2535	2075(V)/2004(H)	-	1495(V)/1290(H)	2	4
BCM_901 C	260	2485	2535	2075(V)/2004(H)	-	1495(V)/1290(H)	2	4
BCM_902 A	420	4585	4635	4175(V)/4104(H)	-	1495(V)/1290(H)	2	4
BCM_902 B	470	4585	4635	4175(V)/4104(H)	-	1495(V)/1290(H)	2	4
BCM_902 C	520	4585	4635	4175(V)/4104(H)	-	1495(V)/1290(H)	2	4
BCM_903 A	645	6685	6735	6275(V)/6204(H)	-	1495(V)/1290(H)	2	4
BCM_903 B	720	6685	6735	6275(V)/6204(H)	-	1495(V)/1290(H)	2	4
BCM_903 C	795	6685	6735	6275(V)/6204(H)	-	1495(V)/1290(H)	2	4
BCM_904 A	860	8785	8835	4175(V)/4104(H)	4200	1495(V)/1290(H)	3	6
BCM_904 B	960	8785	8835	4175(V)/4104(H)	4200	1495(V)/1290(H)	3	6
BCM_904 C	1060	8785	8835	4175(V)/4104(H)	4200	1495(V)/1290(H)	3	6
Ø 1000								
BCM_1001 A	210	2485	2535	2075(V)/2004(H)	-	1495(V)/1290(H)	2	4
BCM_1001 B	235	2485	2535	2075(V)/2004(H)	-	1495(V)/1290(H)	2	4
BCM_1001 C	260	2485	2535	2075(V)/2004(H)	-	1495(V)/1290(H)	2	4
BCM_1002 A	420	4585	4635	4175(V)/4104(H)	-	1495(V)/1290(H)	2	4
BCM_1002 B	470	4585	4635	4175(V)/4104(H)	-	1495(V)/1290(H)	2	4
BCM_1002 C	520	4585	4635	4175(V)/4104(H)	-	1495(V)/1290(H)	2	4
BCM_1003 A	645	6685	6735	6275(V)/6204(H)	-	1495(V)/1290(H)	2	4
BCM_1003 B	720	6685	6735	6275(V)/6204(H)	-	1495(V)/1290(H)	2	4
BCM_1003 C	795	6685	6735	6275(V)/6204(H)	-	1495(V)/1290(H)	2	4
BCM_1004 A	860	8785	8835	4175(V)/4104(H)	4200	1495(V)/1290(H)	3	6
BCM_1004 B	960	8785	8835	4175(V)/4104(H)	4200	1495(V)/1290(H)	3	6
BCM_1004 C	1060	8785	8835	4175(V)/4104(H)	4200	1495(V)/1290(H)	3	6

Standard feet 500 mm.

We reserve the right to change our technical data without prior notice.

BCM VERTICAL POSITION BCM HORIZONTAL POSITION

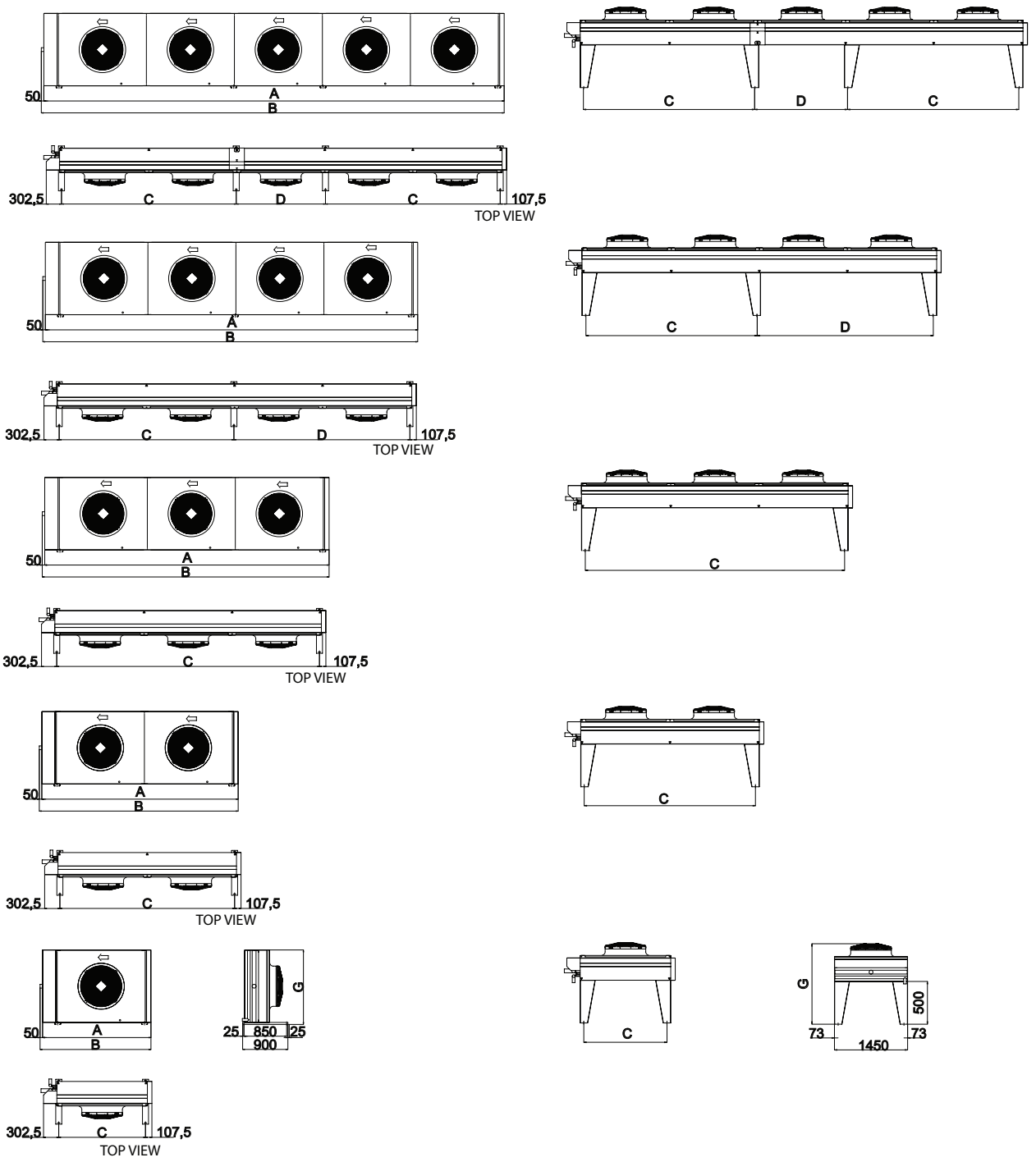

HORIZONTAL POSITION								
Model	Weight [Kg]	Dimension (mm)					N° feet	
		A	B	C	D	F	H	V
Ø 630								
BNM_631 A	120	1605	994	-	1225	1215	2	4
BNM_631 B	135	1605	994	-	1225	1215	2	4
BNM_631 C	150	1605	994	-	1225	1215	2	4
BNM_632 A	240	2695	2084	-	1225	1215	2	4
BNM_632 B	270	2695	2084	-	1225	1215	2	4
BNM_632 C	300	2695	2084	-	1225	1215	2	4
BNM_633 A	360	3785	3174	-	1225	1215	2	4
BNM_633 B	405	3785	3174	-	1225	1215	2	4
BNM_633 C	450	3785	3174	-	1225	1215	2	4
BNM_634 A	480	4875	2084	2180	1225	1215	3	6
BNM_634 B	540	4875	2084	2180	1225	1215	3	6
BNM_634 C	600	4875	2084	2180	1225	1215	3	6
Ø 630 LONG								
BNM_631 AL	150	1915	1304	-	1225	1215	2	4
BNM_631 BL	170	1915	1304	-	1225	1215	2	4
BNM_631 CL	190	1915	1304	-	1225	1215	2	4
BNM_632 AL	300	3315	2704	-	1225	1215	2	4
BNM_632 BL	340	3315	2704	-	1225	1215	2	4
BNM_632 CL	380	3315	2704	-	1225	1215	2	4
BNM_633 AL	450	4715	4104	-	1225	1215	2	4
BNM_633 BL	510	4715	4104	-	1225	1215	2	4
BNM_633 CL	570	4715	4104	-	1225	1215	2	4
Ø 800								
BNM801 A	190	2265	1654	-	1250	1455	2	4
BNM801 B	215	2265	1654	-	1250	1455	2	4
BNM801 C	240	2265	1654	-	1250	1455	2	4
BNM802 A	380	4015	3404	-	1250	1455	2	4
BNM802 B	430	4015	3404	-	1250	1455	2	4
BNM802 C	480	4015	3404	-	1250	1455	2	4
BNM803 A	570	5765	5154	-	1250	1455	2	4
BNM803 B	645	5765	5154	-	1250	1455	2	4
BNM803 C	720	5765	5154	-	1250	1455	2	4
BNM804 A	760	7515	3404	3500	1250	1455	3	6
BNM804 B	860	7515	3404	3500	1250	1455	3	6
BNM804 C	960	7515	3404	3500	1250	1455	3	6
BNM805 A	950	9265	3404	1846	1250	1455	4	8
BNM805 B	1075	9265	3404	1846	1250	1455	4	8
BNM805 C	1200	9265	3404	1846	1250	1455	4	8

The information is for the horizontal version with 500mm standard feet.

We reserve the right to change our technical data without prior notice.

HORIZONTAL POSITION								
Model	Weight [Kg]	Dimension (mm)					N° feet	
		A	B	C	D	F	H	V
Ø 910								
BNM901 A	230	2615	2004	-	1290	1455	2	4
BNM901 B	260	2615	2004	-	1290	1455	2	4
BNM901 C	290	2615	2004	-	1290	1455	2	4
BNM902 A	460	4715	2004	-	1290	1455	2	4
BNM902 B	520	4715	2004	-	1290	1455	2	4
BNM902 C	580	4715	2004	-	1290	1455	2	4
BNM903 A	690	6815	6204	-	1290	1455	2	4
BNM903 B	780	6815	6204	-	1290	1455	2	4
BNM903 C	870	6815	6204	-	1290	1455	2	4
BNM904 A	920	8915	4104	4200	1290	1455	3	6
BNM904 B	1040	8915	4104	4200	1290	1455	3	6
BNM904 C	1160	8915	4104	4200	1290	1455	3	6
Ø 1000								
BNM1001 A	230	2615	2004	-	1290	1455	2	4
BNM1001 B	260	2615	2004	-	1290	1455	2	4
BNM1001 C	290	2615	2004	-	1290	1455	2	4
BNM1002 A	460	4715	2004	-	1290	1455	2	4
BNM1002 B	520	4715	2004	-	1290	1455	2	4
BNM1002 C	580	4715	2004	-	1290	1455	2	4
BNM1003 A	690	6815	6204	-	1290	1455	2	4
BNM1003 B	780	6815	6204	-	1290	1455	2	4
BNM1003 C	870	6815	6204	-	1290	1455	2	4
BNM1004 A	920	8915	4104	4200	1290	1455	3	6
BNM1004 B	1040	8915	4104	4200	1290 <td 1455	3	6	
BNM1004 C	1160	8915	4104	4200	1290	1455	3	6

Standard feet 500 mm.

We reserve the right to change our technical data without prior notice.

BNM HORIZONTAL POSITION

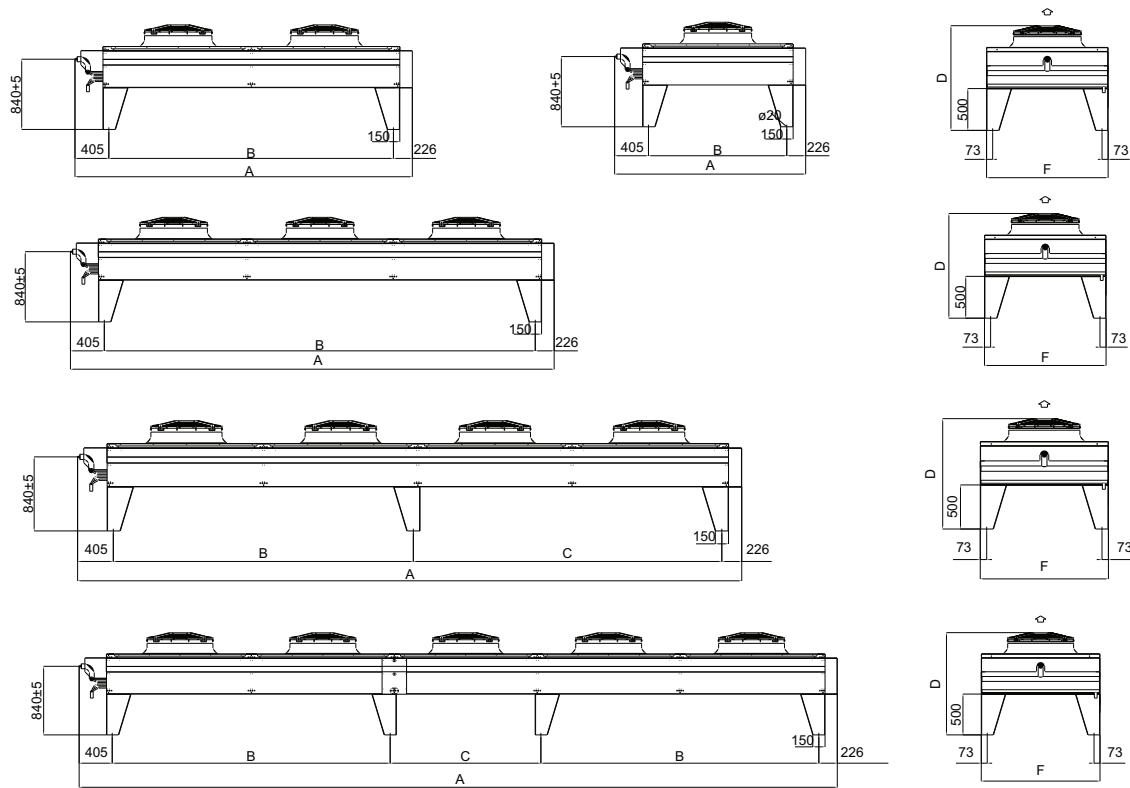

BCM/BNM - Single Fan Row

Options

Motor fans



(a) Fan motor 400 V/3ph - 60Hz, IP54: Q/R for Ø 630/800/910/1000 and also S/L for Ø 630/800/910
 (b) Fan motor 460 V/3ph - 60Hz, IP54: Q/R for Ø 630/800/910/1000 and also S/L for Ø 630/800/910
 (c) Fan motor 230V/1ph - 50/60Hz, IP54: L/Q for Ø 630

Model:
 Ø 630(a,b,c)
 Ø 630 L(a,b,c)
 Ø 800 (a,b)
 Ø 910(a,b)
 Ø1000 (a,b)

Local safety switch wired



See Electrical Data Page.

Model:
 All Models

Local safety switch EMC



See Electrical Data Page.

Model:
 All Models

Terminal Box

See Electrical Data Page.

Model:
 All Models

Switchboard and cabling		
	<p>Function</p> <p>Switchboard for supply and control of fan motors.</p> <p>A switchboard can supply up to 8 individual motors or 8 paired motors (i.e. max. of 16 motors).</p> <p>Switchboard and cabling are supplied as standard for vertical installation of the unit.</p> <p>If you have different needs, please specify these when placing your order.</p> <p>Operating conditions</p> <p>Type of installation: External wall mounted</p> <p>Protection class: IP55 door closed</p> <p>Climate: Normal</p> <p>Operating temperature: $-10 \div +35^{\circ}\text{C}$ (base) $-25 \div +50^{\circ}\text{C}$ (with options)</p> <p>Ambient relative humidity: <95%</p> <p>Altitude: <1000metres above sea level</p> <p>Electrical data</p> <p>Insulating nominal voltage: 690V</p> <p>Operating voltage: 3Ph. 400Vac</p> <p>Frequency: 50Hz</p> <p>Auxiliaries voltage: 24-230V</p> <p>Nominal current: Max 80A</p> <p>Mechanical data</p> <p>Material: Pre-painted galvanized steel</p> <p>Fixing plate: Sheet of steel (min. thickness 15/10 Sendzimir galvanized)</p> <p>Gasket: Polyurethane</p> <p>Door: opening more than 180°.</p> <p>Colour: RAL 7035</p> <p>Cable gland: metric ISO</p>	<p>Model:</p> <p>All Models</p>
Switchboard Options		
	<p>R anti-condensate resistor 230Vac (operating temperature $-25 \div +35^{\circ}\text{C}$)</p> <p>C cooling fan 230Vac (operating temperature $-10 \div +50^{\circ}\text{C}$)</p> <p>F cooling fan + anti-condensate resistor</p>	<p>Model:</p> <p>All Models</p>
Switchboard with Fan Speed control		
	<p>Switchboard and cabling including an electronic fan motor speed controller. This equipment continually checks and regulates the rotation speed of the fan's motor, keeping the condensing pressure within the range or pre-defined values. Constant control of the fan speed is achieved by variation of the electrical supply by phase-cut, as determined by the probe signal. The fan speed controller comes pre-connected to the switchboard. If you have different needs, please specify these when placing your order.</p>	<p>Model:</p> <p>All Models</p>
Switchboard with Fan Step control		
	<p>Switchboard and cabling including an automatic on/off switch that checks and regulates the rotation speed of the fan's motor, keeping the condensing pressure within the range or pre-defined values. Control of the fan speed is achieved by variation of the electrical supply by the ON/OFF device, as determined by the probe signal. The fan step controller comes pre-connected to the switchboard. If you have different needs, please specify these when placing your order.</p>	<p>Model:</p> <p>All Models</p>
Switchboard with Frequency Converter (Inverter)		
	<p>See Electrical Data Page.</p>	<p>Model:</p> <p>All Models</p>
Coil Treatment / Material		
	<p>Thermoguard for industrial or sea coast application.</p> <p>Aluminium fins pre-coated.</p> <p>Copper fins.</p> <p>Application Use: More information on corrosion prevention can be found in the Miscellaneous section.</p>	<p>Model:</p> <p>All Models</p>

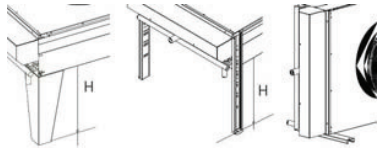
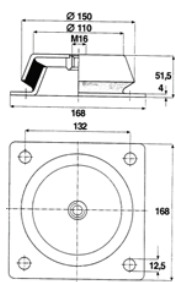
Multi-circuits															
	<p>All models are suitable for multi-circuits, enabling more than one refrigeration system to operate with a single condenser.</p> <p>Model: All Models</p>														
Sub-cooling circuit															
	<p>Sub-cooling is achieved by the use of an integrated sub-cooling section which harnesses approximately 10% of the coil surface. This provides 6-7°C max. of sub-cooling at the standard rate condition of 15K. The overall effect on the condensing capacity is a reduction of 10%. However, the overall heat rejection inclusive of sub-cooling capacity will only be reduced by 5%.</p> <p>Model: All Models</p>														
Non-standard fin spacing															
	<p>The standard fin spacing is 2.1mm. Alternative: 2.5mm and 3.2mm.</p> <p>Model: All Models</p>														
Feet															
	<p>H Horizontal Position (500 and 850mm) A Feet adjustable from 350-950cm V Vertical Position</p> <p>Model: All Models</p>														
Vibration Dampers															
	<table border="1"> <thead> <tr> <th>Type</th> <th>H mm</th> <th>A mm</th> <th>B mm</th> <th>C mm</th> <th>D mm</th> <th>Weight Kg</th> </tr> </thead> <tbody> <tr> <td>Single Row</td> <td>51.5</td> <td>132</td> <td>168</td> <td>M16</td> <td>12.5</td> <td>2.15</td> </tr> </tbody> </table> <p>Nuts and bolts are not included with these dampers.</p> <p>Model: All Models</p>	Type	H mm	A mm	B mm	C mm	D mm	Weight Kg	Single Row	51.5	132	168	M16	12.5	2.15
Type	H mm	A mm	B mm	C mm	D mm	Weight Kg									
Single Row	51.5	132	168	M16	12.5	2.15									

BCM/BNM - Single Fan Row

Electrical Data

Safety Switch

Function

Local safety switch and cabling for each electric fan motor.

General data

Power Supply:

- 400VAC, 50/60Hz
- Max fuse 16A

Number of poles: 3P

Cabinet Material: Plastic Case

Cabinet Colour: Grey (Yellow-Red Knob)

Protection Class: Min IP65

Ambient Temp.: min. -25°C, max. +50°C

Weight: Approx. 0.4Kg

Dimensions

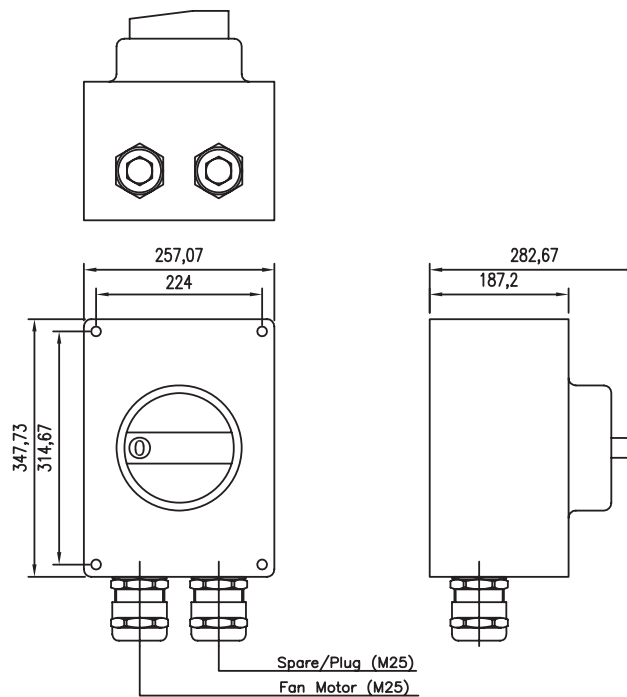

Safety Switch EMC

Function

Local safety switch and cabling for each electric fan motor.

General data

Power Supply:

- 400VAC, 50/60Hz
- Max fuse 16A

Number of poles: 3P

Cabinet Material: Plastic case with internal copper-painted

Cabinet Colour: Grey (Yellow-Red Knob)

Protection Class: Min IP65

Ambient Temp.: min. -25°C, max. +50°C

Weight: Approx. 0.4Kg

Dimensions

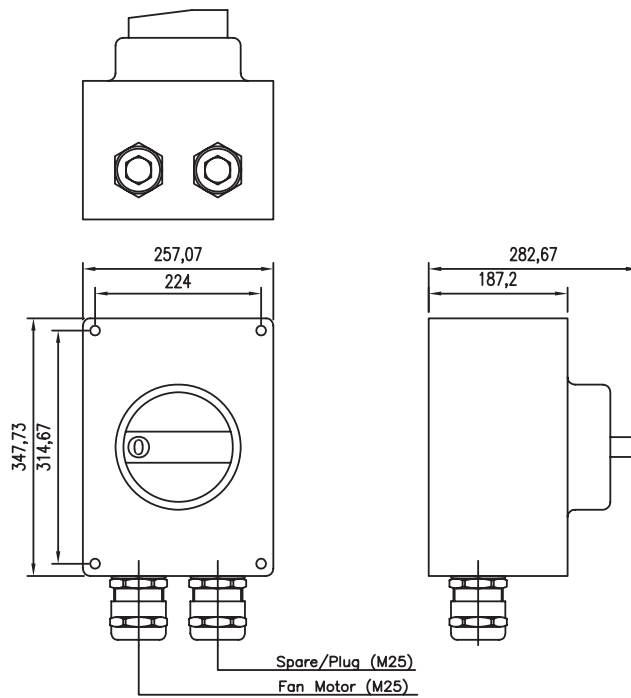

Terminal Box

Function

Connection box for electric fan motor

General data

Material: Plastic
 IP Protection Class: Min RAL 7035
 Colour: Grey RAL 7035
 Insulation Class: II
 Ambient Temp.: min. -40°C, max. +80°C
 Weight: Approx. 0.5Kg.

Dimensions

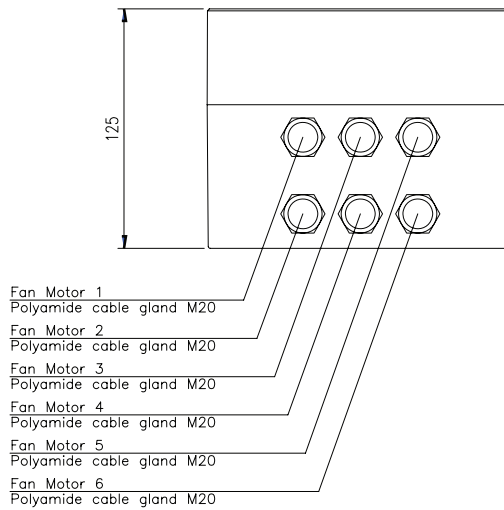
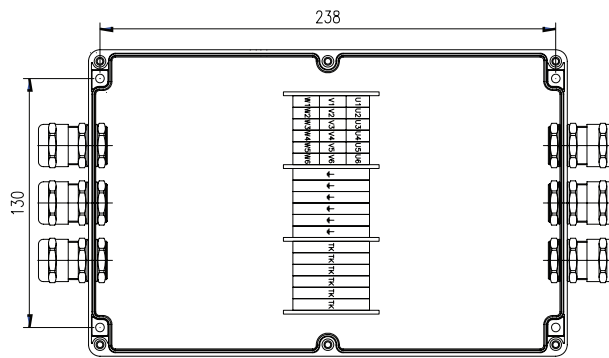

Switch Board (Control Panel)

Function

Basic Version for Horizontal Installation

General data

- Cabinet Material: Sheet steel 15/10mm zinc-coated
- Internal Plate: Sheet steel 20/10mm zinc-coated
- Protection Class: IP 55
- Cabinet Colour: RAL 7035, light grey polyester paint
- Cabinet Doors: Opening angle 110°
- Ambient Temp.:
 - min. -10°C, max. +35°C standard
 - min. -25°C, max. +35°C with electrical heater
 - min. -10°C, max. +50°C with cooling fan
 - min. -25°C, max. +50°C with heater and fan

Cables included: Bottom position with cable glands.

Dimensions

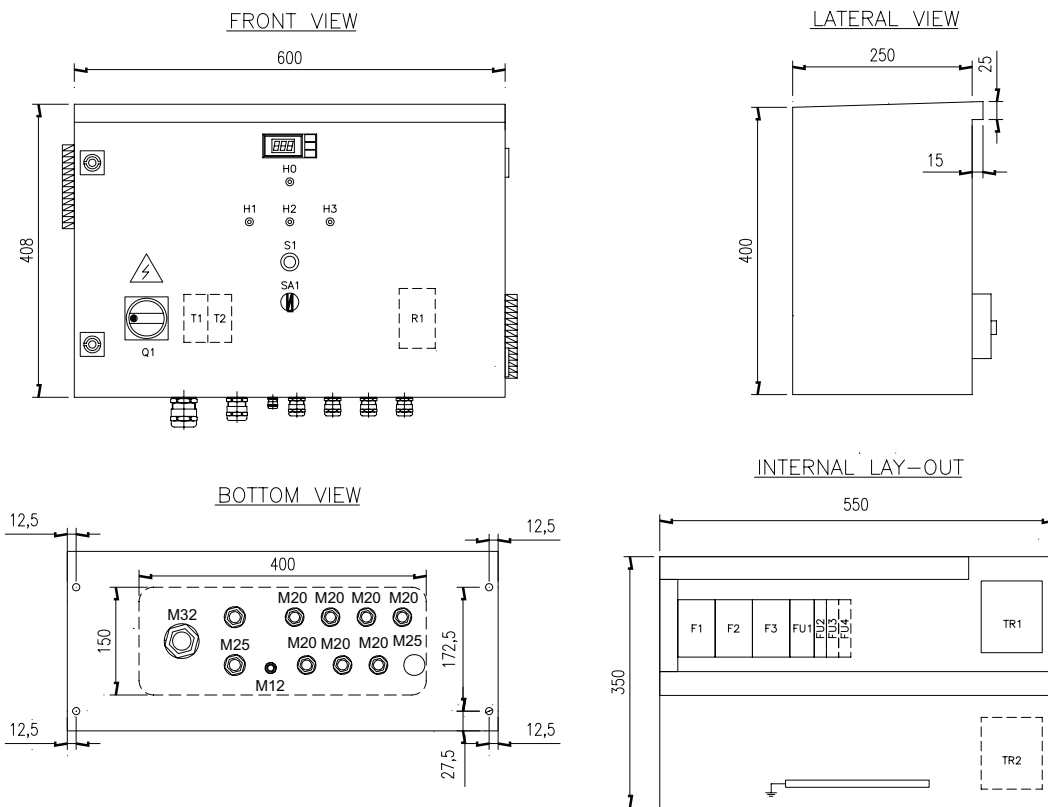

Labels list

- | | |
|-----------------------------------|--|
| H0 VOLTAGE BOARD ON | Q1 MAIN SWITCH |
| H1 FAN MOTOR 1–2 RUNNING (OPTION) | TC1 TEMPERATURE/PRESSURE CONTROLLER (OPTION) |
| H2 FAN MOTOR 3–4 RUNNING (OPTION) | S1 RESET (OPTION) |
| H3 FAN MOTOR 5–6 RUNNING (OPTION) | SA1 MAN – AUT SELECTION (OPTION) |

Electric wiring diagram

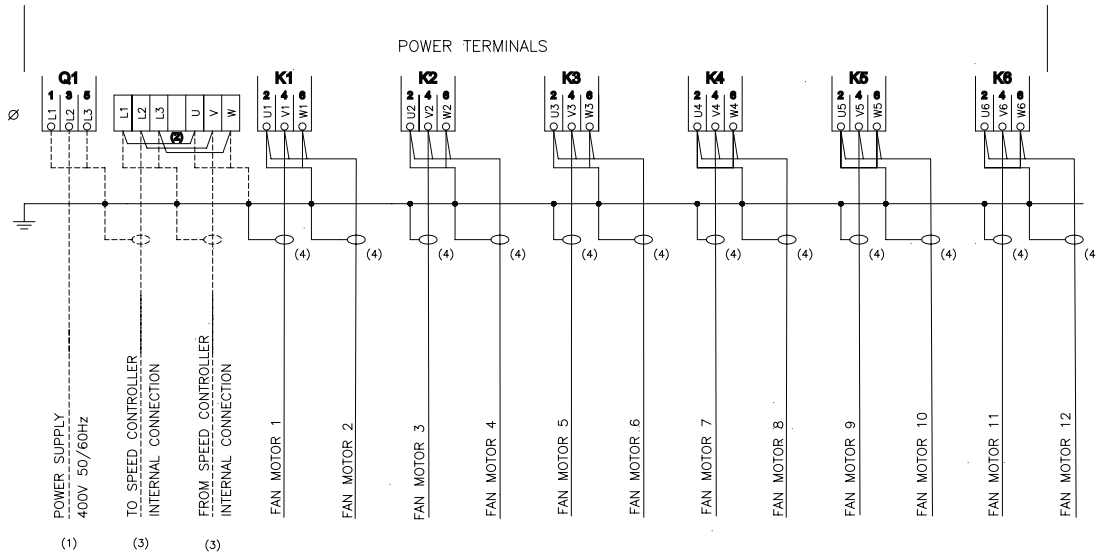

- NOTE:**
- (1) EXTERNAL SHORT CIRCUIT PROTECTION MAX FUSE
 - (2) REMOVE JUMPERS WHEN SPEED CONTROLLER IS ORDERED
 - (3) NOT MOUNTED WHEN FAN SPEED CONTROLLER IS ORDERED
 - (4) SHIELDED CABLE TO BE USED ONLY WHEN EMC CABLING OPTION IS REQUESTED
- CABLE NOT INCLUDED IN ALFA LAVAL DELIVERY
 _____ CABLE INCLUDED IN ALFA LAVAL DELIVERY

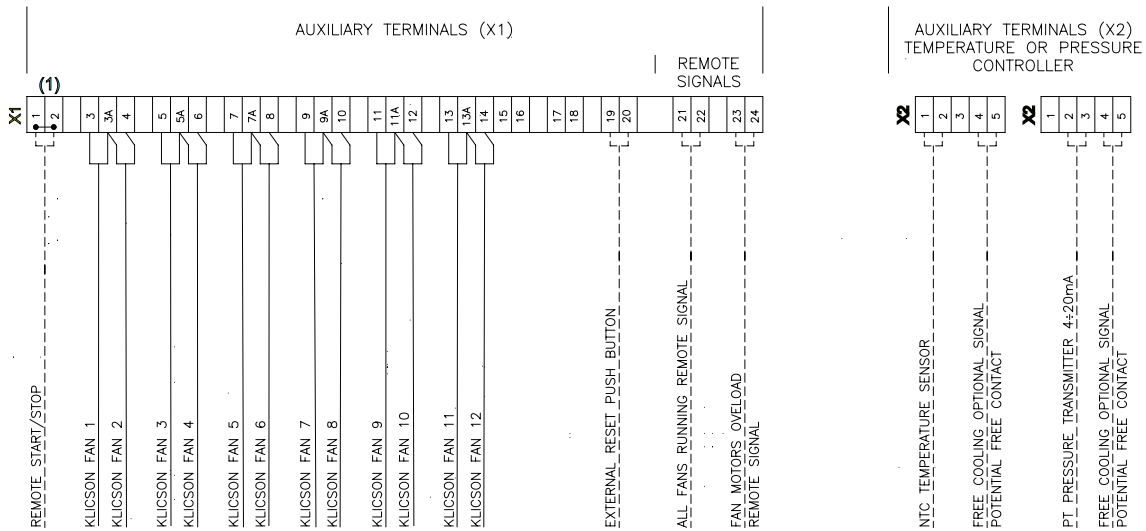

- NOTE:**
- (1) REMOVE JUMPER WHEN USED

Switch Board (Control Panel)

Function

Basic Version for Vertical Installation

General data

Cabinet Material: Sheet steel 15/10mm zinc-coated

Internal Plate: Sheet steel 20/10mm zinc-coated

Protection Class: IP 55

Cabinet Colour: RAL 7035, light grey polyester paint

Cabinet Doors: Opening angle 110°

Ambient Temp.:

- min. -10°C, max. +35°C standard
- min. -25°C, max. +35°C with electrical heater
- min. -10°C, max. +50°C with cooling fan
- min. -25°C, max. +50°C with heater and fan

Cables included: Bottom position with cable glands.

Dimensions

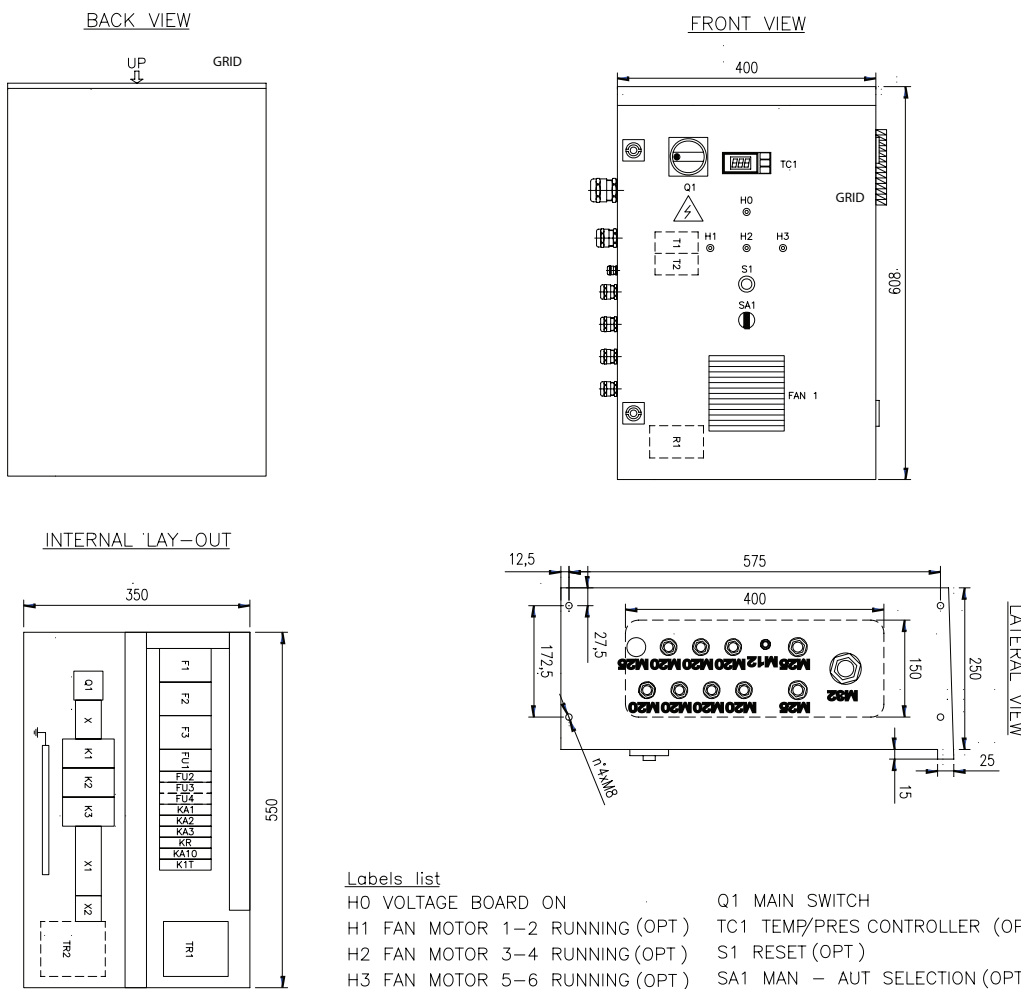

Labels list

- | | |
|--------------------------------|--------------------------------|
| H0 VOLTAGE BOARD ON | Q1 MAIN SWITCH |
| H1 FAN MOTOR 1-2 RUNNING (OPT) | TC1 TEMP/PRES CONTROLLER (OPT) |
| H2 FAN MOTOR 3-4 RUNNING (OPT) | S1 RESET (OPT) |
| H3 FAN MOTOR 5-6 RUNNING (OPT) | SA1 MAN - AUT SELECTION (OPT) |

Electric wiring diagram

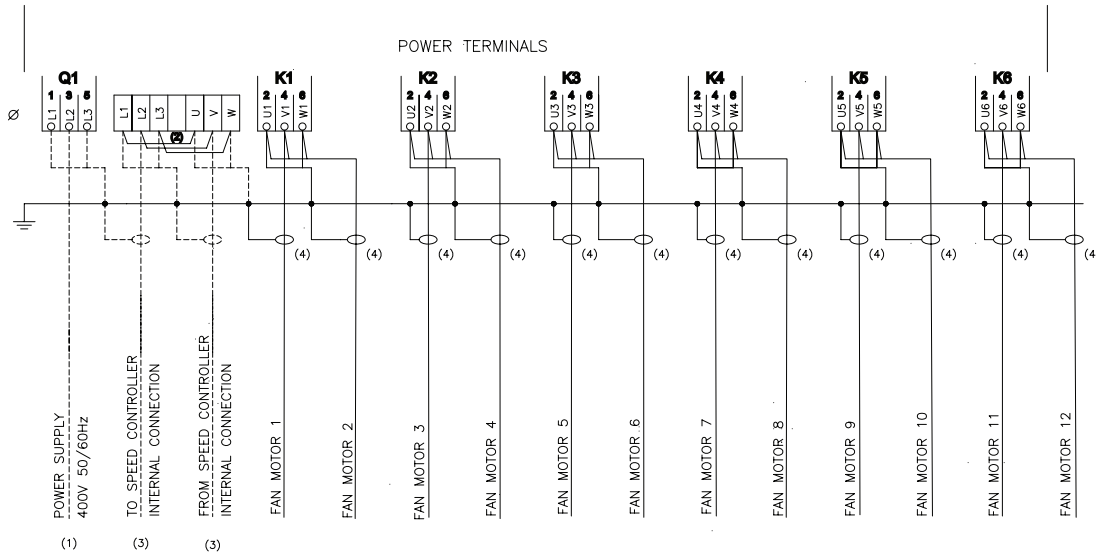

- NOTE:**
- (1) EXTERNAL SHORT CIRCUIT PROTECTION MAX FUSE
 - (2) REMOVE JUMPERS WHEN SPEED CONTROLLER IS ORDERED
 - (3) NOT MOUNTED WHEN FAN SPEED CONTROLLER IS ORDERED
 - (4) SHIELDED CABLE TO BE USED ONLY WHEN EMC CABLING OPTION IS REQUESTED
- CABLE NOT INCLUDED IN ALFA LAVAL DELIVERY
 _____ CABLE INCLUDED IN ALFA LAVAL DELIVERY

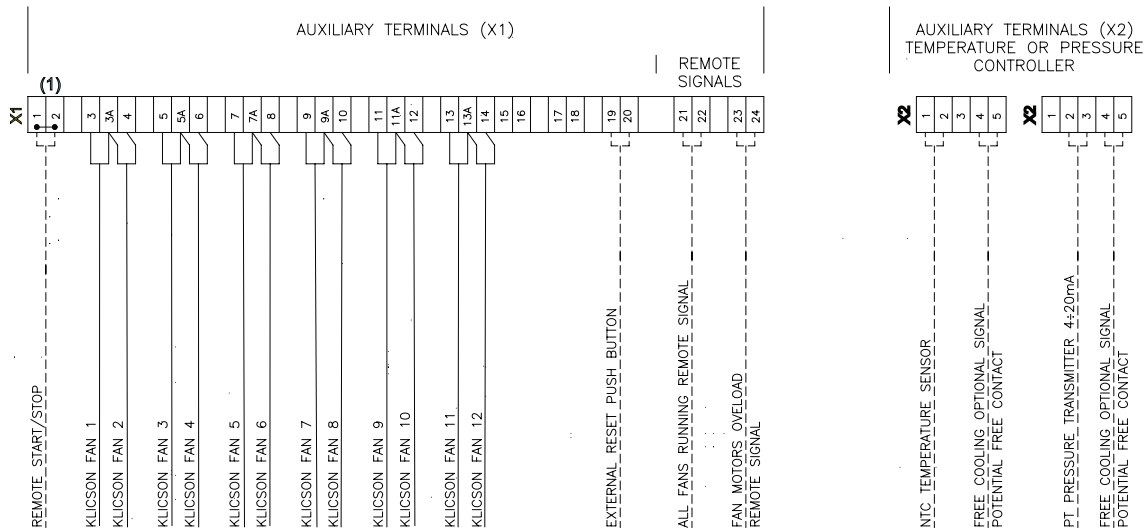

- NOTE:**
- (1) REMOVE JUMPER WHEN USED

Current Distribution

Function

Current distributors are available as optional accessories. Numerous fans can be connected. In combination with Fcontrol frequency inverters, we can deliver the current distribution with both main switch and bypass function. Features: The current distributor is equipped with plastic housing IP54 and motor protection units STDT16E with status signal contacts ZB. It is possible to lock the motor protection units with a padlock and use them as repair switches. Fans are directly connected to the motor protection units. Line protection is guaranteed through the integrated short-circuit release. Terminals for supplying the controller output are also integrated. The current distributors are suitable for external mounting (e.g. direct mounting at refrigeration units). It's easy to see the switch position of the motor protection units through the coloured, transparent plastic door.

General data

Current distributor with main switch and bypass function:

- The controller is supplied by the current distributor
- Main switch: 100% - 0 -1
- In position 100%, the connection to the controller output is switched off. This version is for Fcontrol frequency inverters .
- Rated current: Up to 80A

Dimensions

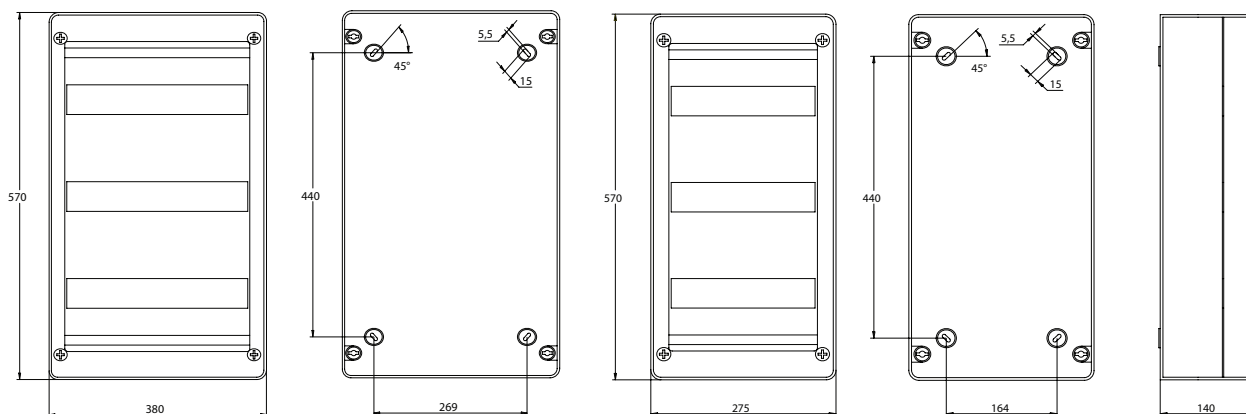

Electric wiring diagram

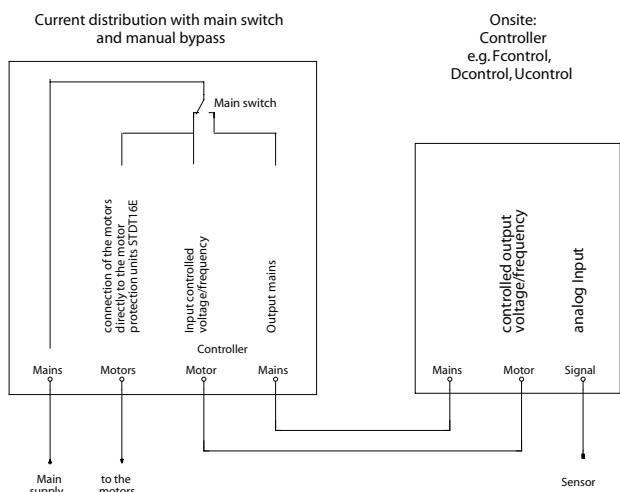

Frequency Converter (Inverter)

Function

Frequency inverter (incl. sine filter) for 3~ motors. Universal controller for refrigeration and air conditioning line input 3~ 208-480V, housing IP54, internal display.

- Speed controller with manual adjustment of output voltage at the unit or via external signal, 2-step operation;
- Temperature control for liquid coolers;
- Pressure control refrigeration (input for refrigerant) for: condensers, dual-circuit condensers;

General data

Equipment/Function

- Integrated SINEFILTER between phase to phase and phase to earth.
- Absolute parallel operation of fans, with no risk of damage to the motor. **Screened motor cables are not required.**
- Integrated process controller (PID free programmable).
- LCD multifunction display with plain language text.
- 2x Analogue Input (0-10 V, 0-20 mA, 4-20 mA, temperature sensor type TF):
 - Analogue 1 for setting of sensor signal.
 - Analogue 2 programmable function for: external set-point, difference value to sensor 1, comparison value (dual-circuit condenser), averaging, and setpoint lowering according to outdoor temperature.
- 1x output 0-10V, programmable function: Constant voltage, proportional modulation, proportional input signal, group control, controller 2.
- 2x digital inputs, programmable function: enable (on / off), external fault, limit output, input 1/2, set-point 1/2, setting internal / external, automatic control / speed manual, reverse control function ("heating" / "cooling"), reset, setting max. speed.
- 2x relay outputs, programmable function: operating indication, fault indication, external fault from digital input, limit modulation, limit input signal, limit offset (deviation actual value setpoint), group control .
- Total motor protection using thermocontact / thermistor connection.
- Interface system with RS485 Interface (MODBUS) or LON® is another alternative option.

Technical data

- Line voltage 3~ 208 BND_480V (-15% / +10%), 50/60Hz.

Rated current*/A	4	8	13	18	22	32	40
Max. line fuse/A	10	10	16	20	25	35	50
Max. heat dissipation*/W	130	210	350	440	540	950	1.100
Weight/Kg	8.8	9.0	22.8	25.4	28.1	29.5	31.8

*at line voltage 400V / 50Hz (for FXDM40A rated current - only possible for fans with $\cos \phi < 0.8$).

- Maximum output frequency 100Hz (for FXDM40, max. 60Hz).
- Clock frequency 16 kHz.
- Max. permissible ambient temperature 40°C (up to 55°C with derating).
- Voltage supply for sensors +24V $\pm 20\%$ (I_{max} 120 mA).
- Permissible rel. humidity 85% with no condensation .
- Interference emission EN 61000-6-3 1 (unshielded motor cable).
- Interference immunity EN 61000-6-2.

Settings

- Quick start-up with pre-programming modes.
- Set-point 1, set-point 2, manual mode.
- Min. and max. speed, speed limitation e.g. for night operation.
- Group control (via relay or 0-10V signal output).
- Limits: Modulation, input signal, offset (deviation set to actual value).
- Set protection, save user settings.
- Readout events memory (checking the fault log).
- Masking up to 3 settable speed ranges.
- Minimum rate of air on / off.
- Edge frequency, max. frequency / voltage, start voltage.
- U/f characteristics: quadratic or linear.
- Menu language: English, German, Italian, Swedish, etc.
- Inverting: Inputs analogue and digital, analogue out, relays.

BCM/BNM - Single Fan Row

Code description

Code No.

BCM/BNM	1	2	3	4
S	63	2	A	

1) Type of noise level (number of dB(A) to reduce compared with "base" version)

	Turbo noise level T	Standard noise level S*	Low noise level L*	Quiet noise level Q*	Residential noise level R*
Fan diameter Ø 630mm Normal/L	-	base	-10	-18	-29
Fan diameter Ø 800mm	-	base	-7	-16	-20
Fan diameter Ø 910 mm	base	-2	-9	-19	-20
Fan diameter Ø 1 000 mm	-	-	base	-14	-16

2) Fan diameter Ø

63	630 mm
80	800 mm
90	910 mm
100	1 000 mm

3) Number of Fans (* available in this version)

	Fan diameter Ø 630mm	Fan diameter Ø 630 mm	Fan diameter Ø 800mm	Fan diameter Ø 910 mm	Fan diameter 1000mm
1	*	*	*	*	*
2	*	*	*	*	*
3	*	*	*	*	*
4	-	*	*	*	*
5	-	-	*	-	-

4) Number of coil rows

A	2
B	3
C	4

General Alfa Select Air Legend

Description 1		Description 2	
D	D fan cabling (three phase)	BSFT	Basic Switch Board + Speed Control Temp. + Signal
Y	Y fan cabling (three phase)	BI	Basic Switch Board + Frequency Converter (Inverter)
D/Y	D/Y fan cabling (three phase), single speed fan motor	BSI	Basic Switch Board + Frequency Converter (Inverter) + Signal
S	Single phase	C	Switch Board + Cooling fan
P	Packaged on a pallet	R	Switch Board + Resistor
CR	Packaged in a crate	F	Switch Board + Cooling fan + Resistor
BO	Packaged in a box	PT	Ammonia pump top
Feet	Feet-mounted	PB	Ammonia pump bottom
SW	Safety Switch	AL	Aluminium casing
CB	Terminal Box	SS	Stainless Steel casing
B	Basic Switch Board	AP	Pre-painted Aluminium casing
BS	Basic Switch Board + Signal	PL	Plastic casing
BP	Basic Switch Board + Step Control Pressure	E	Electrical defrost
PT	Basic Switch Board + Step Control Temperature	LE	Low Electrical defrost
BSP	Basic Switch Board + Step Control Pressure + Signal	A	Air Defrost
BST	Basic Switch Board + Step Control Temp. + Signal	HG	Hot Gas Defrost
BFP	Basic Switch Board + Speed Control Pressure	HG+E	Hot Gas Defrost + Electrical Defrost on drip tray
BFT	Basic Switch Board + Speed Control Temperature	W	Water Defrost
BSFP	Basic Switch Board + Speed Control Pres. + Signal	W+E	Water Defrost + Electrical Defrost on drip tray
AL	Aluminium fin	CU	Copper fin
CU	Copper fin	PR	Pre-coated fin
PR	Pre-coated fin	SS	Stainless steel tube
SS	Stainless steel tube	TH	Thermoguard treatment
TH	Thermoguard treatment	CF	Cataphoresis treatment
CF	Cataphoresis treatment	SC	Sub-cooling circuit
SC	Sub-cooling circuit	kW	Spray water kit
kW	Spray water kit	FL	Flanges
FL	Flanges	FH	Fan ring heater
FH	Fan ring heater	IS	Insulated Drip Tray
IS	Insulated Drip Tray	RH	Reheating coil
RH	Reheating coil	SR	Air socket adapter ring
SR	Air socket adapter ring	CW	Air throw fan cowling
CW	Air throw fan cowling	ER	120° elbow reducer
ER	120° elbow reducer	HN	Hinged fan cowling
HN	Hinged fan cowling		

Note: valid for the entire product range

BCD - Double Fan Row

Product description

Application

The Alfa Laval Condenser can be used in refrigeration and air conditioning equipment

Standard design

Coil

The innovative heat exchanger gives excellent heat transfer with minimised refrigerant charge, thanks to the new fin corrugations developed by Alfa Laval, combined with advance cross-fin tubes. The standard heat exchanger is manufactured from copper tubes and aluminium fins with 2.1mm spacing.

In the BCD, double connection creates the option of having two completely independent heat exchangers. Each heat exchanger undergoes a pressure and leak test with dry air at 34 bar (design pressure is 31 bar), before being supplied with a nitrogen pre-charge.

Casing

Casework made with pre-painted galvanized steel sheets. A new frame design provides high rigidity for heavy applications. The new system protects the heat exchanger tubes completely during transportation and against vibration and thermal expansion while in operation.

Supports manufactured in galvanized steel, with optimized length to permit uniform air suction in the coil.

Benefits

- Footprint: optimized footprint with higher capacity
- 630, 800, 910, 1000 mm fan:
 - More performance available
 - Low power consumption fan motor
 - More noise level options
 - Flexible design
- RAL 9002 all parts painted:
 - No cut edges
 - Higher corrosion resistance, double surface treatment
 - External Corrosion Class C4
- Coil design: increased heat transfer thanks to innovative fin corrugations
- Casing: strong casing with new design
- High Energy Efficiency: best performance with low energy consumption

Options

- Non-standard fin spacing: for heavy dusty environment
- Multi-circuits: total capacity split in multiple compressor lines
- Sub-cooling circuit: Additional circuit to further cool the condensate.
- Spray water device:
 - Smaller units can be selected.
 - Maintain performance during outdoor temperature peaks.



- Coil treatment: corrosion resistance
- Vibration Dampers: for reducing vibrations
- Electrical parts:
 - Switch on/off: Local safety switch is wired to isolate the fan, and is also available for EMC switches.
 - Terminal Box: all fans wired for an easy electrical connection
 - Switchboard
- Cabling: ready to install
- Frequency Converter design: units can run under frequency control (when air temperature is below the design, it allows Energy saving, noise reduction and longer fan motor life.
- Fan step control:
 - Energy saving
 - Cheapest method of controlling performance

- Fan speed control:
 - Energy saving
 - Noise reduction when air temperature is below the design temperature.
 - Variable and efficient speed control according to the heat rejected
 - Better performance control
- Special fans:
 - 480/3ph-60Hz IP54: High adaptability on every market.
 - IP 55: Highly durable fan to be used in tropical or desert areas.
 - High temperature Electric Motors: Fans to be used when air temperature is higher than recommended for standard fans.

Fans

The BCD has 800, 910 and 1000mm diameter fans with a 400V-50Hz three-phase motor. The motors come with external rotors, protection class IP 54 according to DIN 40050. This Axial Condenser is available in five noise levels: (S) standard, (L) low, (Q) quiet, (R) residential and the new (T) high performance fan. The motors are fitted with a thermal contact. The fans are suitable for operation in air temp. application between -40°C and +40°C.

For air temperature lower than +20°C, the full load current (FLC) can be calculated by using the correction factor table. The overload protectors should have a 20% margin to accommodate fan motor supplier variations.

T [°C]	20	10	0	-10	-15	-20	-25	-30
Fc	1	1,04	1,08	1,12	1,14	1,16	1,18	1,2

Model	Capacity [kW]		Airflow [m³/h]		Lp [dB(A)]*		Motor (3/400V-50Hz)		Fans	E.E.C.**		Sur-face	Tube volume	Conn. Size			
	Δ	Y	Δ	Y	Δ	Y	Δ	Y	N° x D [mm]	Δ	Y	m²	dm³	mm			
	Ø 800																
BCDS 802 A	212,0	185,7	89076	69420	56	51	P=2000W I _n =4.0A n=880min-1	P=1250W I _n =2.3A n=660min-1	4x800	E	D	512,9	45	2x54	2x42		
BCDS 802 B	266,4	225,7	84978	65353	56	51			4x800	D	C	769,3	68	2x54	2x42		
BCDS 802 C	299,0	246,1	81131	61704	56	51			4x800	D	C	1025,7	90	2x54	2x42		
BCDL 803 A	310,3	270,9	133514	104028	58	53			6x800	E	D	765,7	67	2x54	2x42		
BCDS 803 B	389,1	329,1	127324	97891	58	53			6x800	D	C	1148,5	101	2x60	2x48		
BCDS 803 C	441,3	367,6	121520	92391	58	53			6x800	D	C	1531,4	134	2x60	2x48		
BCDS 804 A	422,9	370,2	177951	138635	59	54			8x800	E	D	1018,5	89	2x60	2x48		
BCDS 804 B	531,2	449,9	169669	130428	59	54			8x800	D	C	1527,8	134	2x76	2x54		
BCDS 804 C	596,0	490,4	161908	123078	59	54			8x800	D	C	2037	179	2x76	2x54		
BCDS 805 B	662,6	564,2	212014	162965	60	55			10x800	D	C	1907	167	2x76	2x54		
BCDS 805 C	746,7	616,6	202296	153765	60	55			10x800	D	C	2542,7	223	2x76	2x54		
BCDS 806 B	775,5	667,4	254358	195502	61	56			12x800	D	C	2286,2	200	2x76	2x54		
BCDS 806 C	882,6	734,5	242684	184451	61	56	12x800	D	C	3048,3	267	2x76	2x54				
BCDL 802 A	181,3	164,4	66512	56197	49	45	P=1050W I _n =2.4A n=680min-1	P=770W I _n =1.5A n=530min-1	4x800	C	C	512,9	45	2x54	2x42		
BCDL 802 B	221,7	195,4	63614	52829	49	45			4x800	C	C	769,3	68	2x54	2x42		
BCDL 802 C	243,6	209,3	60848	49840	49	45			4x800	C	B	1025,7	90	2x54	2x42		
BCDL 803 A	264,5	239,5	99697	84210	51	47			6x800	C	C	765,7	67	2x54	2x42		
BCDL 803 B	333,3	294,0	95319	79129	51	47			6x800	C	C	1148,5	101	2x60	2x48		
BCDL 803 C	364,0	314,5	91143	74626	51	47			6x800	C	B	1531,4	134	2x60	2x48		
BCDL 804 A	361,5	327,8	132883	112223	52	48			8x800	C	C	1018,5	89	2x60	2x48		
BCDL 804 B	442,1	389,5	127024	105428	52	48			8x800	C	C	1527,8	134	2x76	2x54		
BCDL 804 C	485,6	417,1	121439	99412	52	48			8x800	C	B	2037	179	2x76	2x54		
BCDL 805 B	554,7	489,9	158728	131728	53	49			10x800	C	C	1907	167	2x76	2x54		
BCDL 805 C	610,7	525,3	151733	124197	53	49			10x800	C	B	2542,7	223	2x76	2x54		
BCDL 806 B	656,8	583,1	190432	158027	54	50			12x800	C	C	2286,2	200	2x76	2x54		
BCDL 806 C	727,6	628,3	182028	148982	54	50	12x800	C	B	3048,3	267	2x76	2x54				
BCDQ 802 A	138,2	116,6	42471	32935	40	33	P=370W I _n =1.2A n=440min-1	P=200W I _n =0.5A n=340min-1	4x800	B	A	512,9	45	2x54	2x42		
BCDQ 802 B	160,4	131,6	40213	30762	40	33			4x800	A	A	769,3	68	2x54	2x42		
BCDQ 803 A	201,1	170,2	63651	49346	42	35			6x800	B	A	765,7	67	2x54	2x42		
BCDQ 803 B	241,5	196,5	60242	46070	42	35			6x800	A	A	1148,5	101	2x60	2x48		
BCDQ 804 A	275,6	232,4	84831	65757	43	36			8x800	B	A	1018,5	89	2x60	2x48		
BCDQ 804 B	319,8	262,1	80269	61378	43	36			8x800	A	A	1527,8	134	2x76	2x54		
BCDQ 805 A	346,8	293,3	106011	82168	44	37			10x800	B	A	1271,3	112	2x76	2x54		
BCDQ 805 B	403,2	328,1	100297	76687	44	37			10x800	A	A	1907	167	2x76	2x54		
BCDQ 806 A	412,4	350,7	127190	98579	45	38			12x800	B	A	1524,2	134	2x76	2x54		
BCDQ 806 B	482,5	394,0	120324	91995	45	38			12x800	A	A	2286,2	200	2x76	2x54		
BCDR 802 A	129,4	94,7	38396	24643	36	25			P=250W I _n =0.62A n=380min-1	P=110W I _n =0.27A n=240min-1	4x800	A	A	512,9	45	2x54	2x42
BCDR 802 B	147,4	104,1	35964	22609	36	25					4x800	A	A	769,3	68	2x54	2x42
BCDR 803 A	188,2	142,3	57533	36912	38	27	6x800	A			A	765,7	67	2x54	2x42		
BCDR 803 B	222,0	155,4	53863	33846	38	27	6x800	A			A	1148,5	101	2x60	2x48		
BCDR 804 A	257,9	188,7	76670	49181	39	28	8x800	A			A	1018,5	89	2x60	2x48		
BCDR 804 B	293,7	207,3	71761	45083	39	28	8x800	A			A	1527,8	134	2x76	2x54		
BCDR 805 A	324,9	238,6	95807	61450	40	29	10x800	A			A	1271,3	112	2x76	2x54		
BCDR 805 B	370,6	257,7	89660	56320	40	29	10x800	A			A	1907	167	2x76	2x54		
BCDR 806 A	387,4	286,5	114944	73719	41	30	12x800	A			A	1524,2	134	2x76	2x54		
BCDR 806 B	444,1	307,1	107558	67557	41	30	12x800	A			A	2286,2	200	2x76	2x54		

Nominal capacities according to standard ENV327(R404A T_{air}=25°C, T_{cond}=40°C, ΔT_{subcool}<3K, ΔT_{superheat}=25K).

*See "General Contents" for more details.

**Energy Efficiency Class: see "General Contents" for more details.

Model	Capacity [kW]		Airflow [m³/h]		Lp [dB(A)]*		Motor (3/400V-50Hz)		Fans	E.E.C.**		Sur-face	Tube vol-ume	Conn. Size			
	Δ	Y	Δ	Y	Δ	Y	Δ	Y	N° x D [mm]	Δ	Y	m²	dm³	mm			
	Inlet																Outlet
Ø 910																	
BCDT902 A	273,7	250,0	127089	104682	62	57	P=3600W I _n =7.2A n=890min-1	P=2500W I _n =4.3A n=700min-1	4x900	E	E	614	54	2x60	2x54		
BCDT902 B	353,9	314,2	122421	99251	62	57			4x900	E	D	921	81	2x60	2x54		
BCDT902 C	405,8	351,2	117301	93969	62	57			4x900	E	D	1228	108	2x60	2x54		
BCDT903 A	413,5	374,9	190549	156917	64	59			6x900	E	E	917,4	80	2x60	2x54		
BCDT903 B	522,9	466,6	183482	148714	64	59			6x900	E	D	1376,1	121	2x60	2x54		
BCDT903 C	604,0	520,3	175746	140749	64	59			6x900	E	D	1834,8	161	2x76	2x60		
BCDT904 A	547,4	499,6	254009	209151	65	60			8x900	E	E	1220,8	107	2x76	2x60		
BCDT904 B	707,3	627,5	244541	198176	65	60			8x900	E	D	1831,1	161	2x76	2x60		
BCDT904 C	810,4	700,7	234189	187529	65	60			8x900	E	D	2441,5	214	2x76	2x60		
BCDT905 B	850,9	764,5	305600	247638	66	61			10x900	E	D	2286,2	200	2x76	2x60		
BCDT905 C	988,4	863,1	292632	234309	66	61	10x900	E	D	3048,3	267	2x76	2x60				
BCDS902 A	234,0	205,7	91754	72235	58	53	P=1650W I _n =3.5A n=860min-1	P=1000W I _n =1.8A n=660min-1	4x900	D	C	614	54	2x60	2x54		
BCDS902 B	293,0	249,6	88398	68934	58	53			4x900	C	C	921	81	2x60	2x54		
BCDS902 C	327,9	272,0	85062	65791	58	53			4x900	C	C	1228	108	2x60	2x54		
BCDS903 A	349,5	305,3	137565	108285	60	55			6x900	D	C	917,4	80	2x60	2x54		
BCDS903 B	436,1	373,0	132496	103304	60	55			6x900	C	C	1376,1	121	2x60	2x54		
BCDS903 C	485,3	401,5	127462	98565	60	55			6x900	C	C	1834,8	161	2x76	2x60		
BCDS904 A	467,6	410,7	183376	144336	61	56			8x900	D	C	1220,8	107	2x76	2x60		
BCDS904 B	585,2	498,3	176594	137674	61	56			8x900	C	C	1831,1	161	2x76	2x60		
BCDS904 C	654,5	542,7	169862	131339	61	56			8x900	C	C	2441,5	214	2x76	2x60		
BCDS905 B	716,9	616,3	220691	172043	62	57			10x900	C	C	2286,2	200	2x76	2x60		
BCDS905 C	808,9	675,2	212261	164113	62	57	10x900	C	C	3048,3	267	2x76	2x60				
BCDL902 A	199,8	161,8	68672	48588	51	44	P=900W I _n =2.2A n=640min-1	P=470W I _n =1.05A n=440min-1	4x900	C	B	614	54	2x60	2x54		
BCDL902 B	242,2	187,4	65933	46101	51	44			4x900	B	B	921	81	2x60	2x54		
BCDL902 C	264,3	197,7	63365	43974	51	44			4x900	B	B	1228	108	2x60	2x54		
BCDL903 A	296,3	238,6	102951	72827	53	46			6x900	C	B	917,4	80	2x60	2x54		
BCDL903 B	362,1	281,1	98820	69083	53	46			6x900	B	B	1376,1	121	2x60	2x54		
BCDL903 C	390,2	297,9	94948	65882	53	46			6x900	B	A	1834,8	161	2x76	2x60		
BCDL904 A	399,0	322,9	137231	97067	54	47			8x900	C	B	1220,8	107	2x76	2x60		
BCDL904 B	483,6	374,0	131707	92064	54	47			8x900	B	B	1831,1	161	2x76	2x60		
BCDL904 C	527,6	394,3	126531	87790	54	47			8x900	B	B	2441,5	214	2x76	2x60		
BCDL905 B	598,9	466,9	164593	115046	55	48			10x900	B	B	2286,2	200	2x76	2x60		
BCDL905 C	656,9	493,5	158114	109698	55	48	10x900	B	B	3048,3	267	2x76	2x60				
BCDQ902 A	153,1	130,0	44663	35145	41	35	P=330W I _n =0.83A n=440min-1	P=185W I _n =0.38A n=330min-1	4x900	A	A	614	54	2x60	2x54		
BCDQ902 B	177,0	145,3	42755	33196	41	35			4x900	A	A	921	81	2x60	2x54		
BCDQ903 A	225,6	191,1	66956	52675	43	37			6x900	A	A	917,4	80	2x60	2x54		
BCDQ903 B	265,6	217,7	64077	49740	43	37			6x900	A	A	1376,1	121	2x60	2x54		
BCDQ904 A	305,7	259,3	89249	70205	44	38			8x900	A	A	1220,8	107	2x76	2x60		
BCDQ904 B	353,3	289,7	85398	66284	44	38			8x900	A	A	1831,1	161	2x76	2x60		
BCDQ905 A	380,1	324,1	111541	87735	45	39	10x900	A	A	1524,2	134	2x76	2x60				
BCDQ905 B	441,5	362,5	106720	82828	45	39	10x900	A	A	2286,2	200	2x76	2x60				
BCDR902 A	143,0	104,1	40313	25977	40	30	P=270W I _n =0.70A n=390min-1	P=140W I _n =0.32A n=250min-1	4x900	A	A	614	54	2x60	2x54		
BCDR902 B	163,2	114,3	38514	24430	40	30			4x900	A	A	921	81	2x60	2x54		
BCDR903 A	210,4	156,1	60432	38932	42	32			6x900	A	A	917,4	80	2x60	2x54		
BCDR903 B	245,0	170,5	57719	36602	42	32			6x900	A	A	1376,1	121	2x60	2x54		
BCDR904 A	285,3	207,7	80552	51887	43	33			8x900	A	A	1220,8	107	2x76	2x60		
BCDR904 B	325,7	227,9	76924	48774	43	33			8x900	A	A	1831,1	161	2x76	2x60		
BCDR905 A	355,6	260,6	100671	64842	44	34			10x900	A	A	1524,2	134	2x76	2x60		
BCDR905 B	407,7	282,9	96128	60946	44	34			10x900	A	A	2286,2	200	2x76	2x60		

Nominal capacities according to standard ENV327(R404A Tair=25°C, Tcond=40°C, ΔTsubcool<3K, ΔTsuperheat=25K).

*See "General Contents" for more details.

**Energy Efficiency Class: see "General Contents" for more details.

Model	Capacity [kW]		Airflow [m³/h]		Lp [dB(A)]*		Motor (3/400V-50Hz)		Fans	E.E.C.**		Surface	Tube volume	Conn. Size			
	Δ	Υ	Δ	Υ	Δ	Υ	Δ	Υ	N° x D [mm]	Δ	Υ	m²	dm³	mm			
	Ø 1000																
															Inlet	Outlet	
BCDL1002 A	263,9	234,4	117369	92038	59	54	P=1250W I _n =2.7A n=530min-1	P=810W I _n =1.55A n=390min-1	4x1000	D	D	614,0	54	2x60	2x54		
BCDL1002 B	331,6	285,0	108874	84557	59	54			4x1000	D	C	921,0	81	2x60	2x54		
BCDL1002 C	369,4	309,0	101362	78236	59	54			4x1000	C	C	1228,0	108	2x60	2x54		
BCDL1003 A	397,4	349,9	175877	137896	61	56			6x1000	D	D	917,4	80	2x60	2x54		
BCDL1003 B	491,2	424,4	163071	126630	61	56			6x1000	D	C	1376,1	121	2x60	2x54		
BCDL1003 C	547,9	456,6	151765	117124	61	56			6x1000	C	C	1834,8	161	2x76	2x60		
BCDL1004 A	527,6	468,1	234384	183754	62	57			8x1000	D	D	1220,8	107	2x76	2x60		
BCDL1004 B	662,0	568,7	217266	168701	62	57			8x1000	D	C	1831,1	161	2x76	2x60		
BCDL1004 C	737,0	616,1	202166	156012	62	57			8x1000	C	C	2441,5	214	2x76	2x60		
BCDL1005 B	802,4	698,1	271461	210772	63	58			10x1000	D	C	2286,2	200	2x76	2x60		
BCDL1005 C	904,9	763,3	252567	194899	63	58	10x1000	C	C	3048,3	267	2x76	2x60				
BCDQ1002 A	211,9	174,6	76191	54791	45	38	P=860W I _n =1.2A n=420 min-1	P=500W I _n =0.97A n=320 min-1	4x1000	C	B	614,0	54	2x60	2x54		
BCDQ1002 B	251,4	195,9	69672	48916	45	38			4x1000	B	B	921,0	81	2x60	2x54		
BCDQ1003 A	314,8	257,7	114156	82053	47	40			6x1000	C	B	917,4	80	2x60	2x54		
BCDQ1003 B	375,3	293,4	104311	73220	47	40			6x1000	B	B	1376,1	121	2x60	2x54		
BCDQ1004 A	423,0	348,2	152120	109315	48	41			8x1000	C	B	1220,8	107	2x76	2x60		
BCDQ1004 B	501,4	390,5	138949	97523	48	41			8x1000	B	B	1831,1	161	2x76	2x60		
BCDQ1005 A	515,9	430,4	190083	136577	49	42			10x1000	C	B	1524,2	134	2x76	2x60		
BCDQ1005 B	619,8	486,9	173587	121827	49	42			10x1000	B	B	2286,2	200	2x76	2x60		
BCDR1002 A	197,8	149,2	67468	42964	43	34			P=670W I _n =1.4A n=380 min-1	P=330W I _n =0.67A n=250 min-1	4x1000	B	A	614,0	54	2x60	2x54
BCDR1002 B	230,4	163,4	61296	38563	43	34					4x1000	B	A	921,0	81	2x60	2x54
BCDR1003 A	293,1	219,7	101080	64352	45	36	6x1000	B			A	917,4	80	2x60	2x54		
BCDR1003 B	344,4	245,0	91759	57722	45	36	6x1000	B			A	1376,1	121	2x60	2x54		
BCDR1004 A	394,8	297,6	134692	85738	46	37	8x1000	B			A	1220,8	107	2x76	2x60		
BCDR1004 B	459,3	325,6	122222	76881	46	37	8x1000	B			A	1831,1	161	2x76	2x60		
BCDR1005 A	484,1	370,4	168303	107125	47	38	10x1000	B			A	1524,2	134	2x76	2x60		
BCDR1005 B	569,9	407,4	152684	96040	47	38	10x1000	B			A	2286,2	200	2x76	2x60		

Nominal capacities according to standard ENV327(R404A Tair=25°C, Tcond=40°C, ΔTsubcool<3K, ΔTsuperheat=25K).

*See "General Contents" for more details.

**Energy Efficiency Class: see "General Contents" for more details.

BND NH₃ - Double Fan Row

Product description

Application

The Alfa Laval condenser with stainless steel tubes was specifically designed for refrigeration plants where ammonia refrigerant is used. The condensers are designed for outdoor operation.

Standard design

Coil

An innovative heat exchanger that gives excellent heat transfer performance, thanks to the new fin pattern and surface corrugation, developed by Alfa Laval, combined with smooth stainless steel tubes. A well proven automatic TIG welding technology is used in the manufacture of the connection tubes. The heat transfer sections are float-mounted which completely protects the heat exchanger tubes during transit, while helping to compensate for stress caused by thermal expansion. In the BND, double connection creates the option of having two completely independent heat exchangers. Each heat exchanger undergoes a pressure and leak test with dry air at 28 bar.

Casing

The BNM and BND are manufactured with the aid of AlfaBlue's innovative design profile that provides sturdy construction, higher rigidity with less weight and secure transport. The standard model has a high corrosion resistance as the casework is made with galvanized steel sheets painted in RAL 9002 (corrosion resistance C4). Supports manufactured in galvanized steel, with optimized length to permit uniform air suction in the coil.

Benefits

- Footprint: optimized footprint with higher capacity
- 800, 910, 1000 mm fan:
 - More performance available
 - Low power consumption fan motor
 - More noise level options
 - Flexible design
- RAL 9002 all parts painted:
 - No cut edges
 - Higher corrosion resistance, double surface treatment
 - External Corrosion Class C4
- Coil design: increased heat transfer thanks to innovative fin corrugations
- Casing: strong casing with new design
- High Energy Efficiency: best performance with low energy consumption

Options

- Non-standard fin spacing: for heavy dusty environment
- Multi-circuits: total capacity split in multiple compressor lines
- Sub-cooling circuit: Additional circuit to further cool the condensate.
- Spray water device:



- Smaller units can be selected.
- Maintain performance during outdoor temperature peaks.
- Coil treatment: corrosion resistance
- Vibration Dampers: for reducing vibrations
- Electrical parts:
 - Switch on/off: Local safety switch is wired to isolate the fan, and is also available for EMC switches.
 - Terminal Box: all fans wired for an easy electrical connection
 - Switchboard
- Cabling: ready to install
- Frequency Converter design: units can run under frequency control (when air temperature is below the design, it allows Energy saving, noise reduction and longer fan motor life.
- Fan step control:
 - Energy saving
 - Cheapest method of controlling performance

- Fan speed control:
 - Energy saving
 - Noise reduction when air temperature is below the design temperature.
 - Variable and efficient speed control according to the heat rejected
 - Better performance control
- Special fans:
 - 480/3ph-60Hz IP54: High adaptability on every market.
 - IP 55: Highly durable fan to be used in tropical or desert areas.
 - High temperature Electric Motors: Fans to be used when air temperature is higher than recommended for standard fans.

Fans

On the BND, 800, 910, 1000mm with 400V-50 Hz three-phase motor. The motors come with external rotors, protection class IP 54 according to DIN 40050, while integrated thermo contacts provide reliable protection against any instances of thermal overload. These BND Axial condensers are available in five fan motor noise levels: (S) standard, (L) low, (Q) quiet, (R) residential and the new (T) high performance fan.

For air temperatures lower than +20°C, the full load current (FLC) can be calculated using the correction factor table. The overload protectors should have a 20% margin to accommodate fan motor supplier variations.

T [°C]	20	10	0	-10	-15	-20	-25	-30
Fc	1	1,04	1,08	1,12	1,14	1,16	1,18	1,2

Model	Capacity [kW]		Airflow [m³/h]		Lp [dB(A)]*		Motor (3/400V-50Hz)		Fans	Surface	Tube volume	Conn. Size	
	Δ	Y	Δ	Y	Δ	Y	Δ	Y	N° x D [mm]	m²	dm³	mm	
												Inlet	Outlet
Ø 800													
BNDS802A	269,65	231,98	87385	67718	56	51	P=2000W I=4A n=880min-1	P=1250W I=2.3 n=680min-1	4 x 800	441,2	61	2x2"	2x1"
BNDS802B	325,5	270,4	82594	63073	56	51			4 x 800	661,8	92	2x2"	2x1"
BNDS802C	351	282,92	78228	59044	56	51			4 x 800	882,4	122	2x2"	2x1"
BNDS803A	398,48	343,78	130959	101458	58	53			6 x 800	658,7	91	2x2"	2x1"
BNDS803B	491,16	407,09	123726	94454	58	53			6 x 800	988	137	2x2"	2x1"
BNDS803C	532,14	427,42	117144	88387	58	53			6 x 800	1317,3	183	2x2"	2x1"
BNDS804A	518,39	449,67	174532	135198	59	54			8 x 800	876,2	122	2x2"	2x1"
BNDS804B	649,12	539,09	164858	125835	59	54			8 x 800	1314,2	182	2x2"	2x1"
BNDS804C	700,33	564,22	156059	117730	59	54			8 x 800	1752,3	243	2x2"	2x1"
BNDS805A	667,8	575,14	218104	168938	60	55			10 x 800	1093,6	152	2x2"	2x1"
BNDS805B	801,83	667,53	205989	157215	60	55			10 x 800	1640,5	228	2x2"	2x1"
BNDS805C	857,96	695,83	194973	147072	60	55			10 x 800	2187,3	303	2x2"	2x1"
BNDS806A	795,47	686,18	261677	202678	61	56			12 x 800	1311,1	182	2x2"	2x1"
BNDS806B	972,74	807,77	247119	188595	61	56			12 x 800	1966,7	273	2x2"	2x1"
BNDS806C	1062,1	852,9	233888	176415	61	56			12 x 800	2622,3	364	2x2"	2x1"
BNDL802A	226,89	202,86	65323	54781	49	45			P=1050W I=2.4 n=680min-1	P=770W I=1.5A n=530min-1	4 x 800	441,2	61
BNDL802B	269,26	232,73	61904	50959	49	45	4 x 800	661,8			92	2x2"	2x1"
BNDL802C	281,75	237,63	58736	47675	49	45	4 x 800	882,4			122	2x2"	2x1"
BNDL803A	336,26	301,11	97901	82073	51	47	6 x 800	658,7			91	2x2"	2x1"
BNDL803B	401,71	347,38	92737	76311	51	47	6 x 800	988			137	2x2"	2x1"
BNDL803C	425,75	358,15	87960	71368	51	47	6 x 800	1317,3			183	2x2"	2x1"
BNDL804A	440,39	395,52	130478	109365	52	48	8 x 800	876,2			122	2x2"	2x1"
BNDL804B	532,11	460,63	123570	101663	52	48	8 x 800	1314,2			182	2x2"	2x1"
BNDL804C	562,14	473,84	117183	95060	52	48	8 x 800	1752,3			243	2x2"	2x1"
BNDL805A	562,8	503,42	163056	136657	53	49	10 x 800	1093,6			152	2x2"	2x1"
BNDL805B	585,42	522,29	154402	127014	53	49	10 x 800	1640,5			228	2x2"	2x1"
BNDL805C	693,38	585,87	146406	118752	53	49	10 x 800	2187,3			303	2x2"	2x1"
BNDL806A	671,31	601,03	195632	163949	54	50	12 x 800	1311,1			182	2x2"	2x1"
BNDL806B	797,42	690,22	185235	152366	54	50	12 x 800	1966,7			273	2x2"	2x1"
BNDL806C	849,83	714,69	175629	142444	54	50	12 x 800	2622,3			364	2x2"	2x1"
BNDQ802A	168,17	139,19	41538	32010	40	33	P=370W I=1.2A n=440min-1	P=200W I=0.5 n=340min-1			4 x 800	441,2	61
BNDQ802B	186,95	148,8	38912	29589	40	33			4 x 800	661,8	92	2x2"	2x1"
BNDQ802C	189,11	146,61	36562	27571	40	33			4 x 800	882,4	122	2x2"	2x1"
BNDQ803A	250,23	207,4	62241	47952	42	35			6 x 800	658,7	91	2x2"	2x1"
BNDQ803B	276,55	220,87	58278	44304	42	35			6 x 800	988	137	2x2"	2x1"
BNDQ803C	278,15	216,85	54738	41268	42	35			6 x 800	1317,3	183	2x2"	2x1"
BNDQ804A	329,75	274,1	82944	63894	43	36			8 x 800	876,2	122	2x2"	2x1"
BNDQ804B	360,98	289,92	77643	59019	43	36			8 x 800	1314,2	182	2x2"	2x1"
BNDQ804C	359,42	282,88	72913	54965	43	36			8 x 800	1752,3	243	2x2"	2x1"
BNDQ805A	405,51	338,56	103647	79835	44	37			10 x 800	1093,6	152	2x2"	2x1"
BNDQ805B	435,93	354,44	97009	73733	44	37			10 x 800	1640,5	228	2x2"	2x1"
BNDQ805C	467,84	363,32	91088	68662	44	37			10 x 800	2187,3	303	2x2"	2x1"
BNDQ806A	499,54	413,99	124349	95776	45	38			12 x 800	1311,1	182	2x2"	2x1"
BNDQ806B	496,45	411,13	116375	88448	45	38			12 x 800	1966,7	273	2x2"	2x1"
BNDQ806C	555,58	432,95	109263	82359	45	38			12 x 800	2622,3	364	2x2"	2x1"
BNDR802A	155,99	110,55	37380	23777	36	25			P=250W I=0.62A n=380min-1	P=110 iW=0.27A n=240min-1	4 x 800	441,2	61
BNDR802B	169,77	112,45	34601	21525	36	25	4 x 800	661,8			92	2x2"	2x1"
BNDR802C	168,88	106,93	32207	19709	36	25	4 x 800	882,4			122	2x2"	2x1"
BNDR803A	232,25	164,93	55999	35606	38	27	6 x 800	658,7			91	2x2"	2x1"
BNDR803B	251,54	167,37	51808	32215	38	27	6 x 800	988			137	2x2"	2x1"
BNDR803C	251,46	160,36	48205	29486	38	27	6 x 800	1317,3			183	2x2"	2x1"
BNDR804A	306,44	218,49	74618	47435	39	28	8 x 800	876,2			122	2x2"	2x1"
BNDR804B	328,97	220,85	69015	42905	39	28	8 x 800	1314,2			182	2x2"	2x1"
BNDR804C	323,09	208,95	64202	39262	39	28	8 x 800	1752,3			243	2x2"	2x1"
BNDR805A	377,57	270,68	93237	59264	40	29	10 x 800	1093,6			152	2x2"	2x1"
BNDR805B	399,87	271,93	86222	53595	40	29	10 x 800	1640,5			228	2x2"	2x1"
BNDR805C	422,08	267,93	80200	49039	40	29	10 x 800	2187,3			303	2x2"	2x1"
BNDR806A	463,6	329,15	111855	71092	41	30	12 x 800	1311,1			182	2x2"	2x1"
BNDR806B	459,45	319,43	103429	64285	41	30	12 x 800	1966,7			273	2x2"	2x1"
BNDR806C	502,1	319,95	96197	58815	41	30	12 x 800	2622,3			364	2x2"	2x1"

Nominal capacities according to R717 Tair=25°C, Tcond=40°C, ΔTsubcool<3K, ΔTsuperheat=25K).

Note: The units are designed for horizontal installation. Vertical installations require special refrigerant circuits.

*See the "General Contents" for more details.

Model	Capacity [kW]		Airflow [m³/h]		Lp [dB(A)]*		Motor (3/400V-50Hz)		Fans	Surface	Tube volume	Conn. Size	
	Δ	Υ	Δ	Υ	Δ	Υ	Δ	Υ	N° x D [mm]	m²	dm³	mm	
												Inlet	Outlet
Ø 910													
BNDT902A	354,99	317,78	125290	102486	62	57	P=3600W I=7.2A n=890min-1	P=2500W I=4.3A n=700min-1	4 x 910	528,2	73	2x2"	2x1"
BNDT902B	434,74	378,9	119310	95984	62	57			4 x 910	792,3	110	2x2"	2x1"
BNDT902C	491,6	414,95	113151	89974	62	57			4 x 910	1056,4	147	2x2"	2x1"
BNDT903A	518,18	466,09	187823	153597	64	59			6 x 910	789,2	109	2x2"	2x1"
BNDT903B	661,24	574,27	178779	143787	64	59			6 x 910	1183,7	164	2x2"	2x1"
BNDT903C	725,77	614,31	169486	134735	64	59			6 x 910	1578,3	219	2x2"	2x1"
BNDT904A	708,1	633,8	250356	204708	65	60			8 x 910	1050,1	146	2x2"	2x1"
BNDT904B	884,01	767,12	238247	191589	65	60			8 x 910	1575,2	219	2x2"	2x1"
BNDT904C	941,82	802,9	225819	179495	65	60			8 x 910	2100,3	291	2x2"	2x1"
BNDT905A	875,78	785,5	312888	255819	66	61			10 x 910	1311,1	182	2x2"	2x1"
BNDT905B	1096,42	952,47	297714	239390	66	61			10 x 910	1966,7	273	2x2"	2x1"
BNDT905C	1217,62	1028,99	282152	224254	66	61			10 x 910	2622,3	364	2x2"	2x1"
BNDS902A	295,52	254,63	90397	70881	58	53	P=1650W I=3.5 n=860min-1	P=1000W I=1.8A n=660min-1	4 x 910	528,2	73	2x2"	2x1"
BNDS902B	353,06	294,93	86350	66990	58	53			4 x 910	792,3	110	2x2"	2x1"
BNDS902C	377,13	307,43	82444	63402	58	53			4 x 910	1056,4	147	2x2"	2x1"
BNDS903A	434,59	375,99	135514	106242	60	55			6 x 910	789,2	109	2x2"	2x1"
BNDS903B	534,51	445,43	129404	100372	60	55			6 x 910	1183,7	164	2x2"	2x1"
BNDS903C	575,09	466,59	123515	94968	60	55			6 x 910	1578,3	219	2x2"	2x1"
BNDS904A	589,57	507,97	180631	141602	61	56			8 x 910	1050,1	146	2x2"	2x1"
BNDS904B	704,82	588,65	172459	133754	61	56			8 x 910	1575,2	219	2x2"	2x1"
BNDS904C	753,33	613,82	164585	126532	61	56			8 x 910	2100,3	291	2x2"	2x1"
BNDS905A	731,42	630,93	225748	176962	62	57			10 x 910	1311,1	182	2x2"	2x1"
BNDS905B	887,07	739,77	215513	167135	62	57			10 x 910	1966,7	273	2x2"	2x1"
BNDS905C	915,21	752,81	205655	158097	62	57			10 x 910	2622,3	364	2x2"	2x1"
BNDL902A	246,88	194,63	67539	47525	51	44	P=900W I=2.2 n=640min-1	P=470W I=1.05A n=440min-1	4 x 910	528,2	73	2x2"	2x1"
BNDL902B	286,3	215,91	64343	44765	51	44			4 x 910	792,3	110	2x2"	2x1"
BNDL902C	299,62	219,19	61412	42451	51	44			4 x 910	1056,4	147	2x2"	2x1"
BNDL903A	364,85	288,76	101242	71227	53	46			6 x 910	789,2	109	2x2"	2x1"
BNDL903B	432,27	325,01	96422	67073	53	46			6 x 910	1183,7	164	2x2"	2x1"
BNDL903C	454,55	330,79	92006	63592	53	46			6 x 910	1578,3	219	2x2"	2x1"
BNDL904A	492,58	388,33	134944	94929	54	47			8 x 910	1050,1	146	2x2"	2x1"
BNDL904B	571,52	430,94	128502	89380	54	47			8 x 910	1575,2	219	2x2"	2x1"
BNDL904C	598,36	437,59	122600	84732	54	47			8 x 910	2100,3	291	2x2"	2x1"
BNDL905A	612	483,35	168647	118631	55	48			10 x 910	1311,1	182	2x2"	2x1"
BNDL905B	718,07	540,32	160581	111687	55	48			10 x 910	1966,7	273	2x2"	2x1"
BNDL905C	734,51	540,71	153193	105872	55	48			10 x 910	2622,3	364	2x2"	2x1"
BNDQ902A	183,81	153,03	43878	34310	41	35	P=330W I=0.83A n=440min-1	P=185W I=0.38A n=330min-1	4 x 910	528,2	73	2x2"	2x1"
BNDQ902B	203,46	163,45	41635	32155	41	35			4 x 910	792,3	110	2x2"	2x1"
BNDQ902C	205,94	161,88	39564	30364	41	35			4 x 910	1056,4	147	2x2"	2x1"
BNDQ903A	272,97	227,73	65771	51418	43	37			6 x 910	789,2	109	2x2"	2x1"
BNDQ903B	299,68	241,96	62388	48175	43	37			6 x 910	1183,7	164	2x2"	2x1"
BNDQ903C	300,85	238,46	59267	45480	43	37			6 x 910	1578,3	219	2x2"	2x1"
BNDQ904A	358,5	300,02	87664	68526	44	38			8 x 910	1050,1	146	2x2"	2x1"
BNDQ904B	387,78	315,62	83140	64194	44	38			8 x 910	1575,2	219	2x2"	2x1"
BNDQ904C	411,14	323,11	78970	60597	44	38			8 x 910	2100,3	291	2x2"	2x1"
BNDQ905A	437,4	368,72	109557	85633	45	39			10 x 910	1311,1	182	2x2"	2x1"
BNDQ905B	460,85	381,95	103893	80213	45	39			10 x 910	1966,7	273	2x2"	2x1"
BNDQ905C	508,59	401,01	98673	75713	45	39			10 x 910	2622,3	364	2x2"	2x1"
BNDR902A	170,4	120,29	39568	25320	40	30	P=270W I=0.70A n=390min-1	P=140W I=0.32A n=250min-1	4 x 910	528,2	73	2x2"	2x1"
BNDR902B	186,33	124,09	37473	23591	40	30			4 x 910	792,3	110	2x2"	2x1"
BNDR902C	188,93	121,34	35567	22133	40	30			4 x 910	1056,4	147	2x2"	2x1"
BNDR903A	253,31	179,38	59309	37942	42	32			6 x 910	789,2	109	2x2"	2x1"
BNDR903B	275,08	184,42	56149	35339	42	32			6 x 910	1183,7	164	2x2"	2x1"
BNDR903C	274,41	178,1	53278	33146	42	32			6 x 910	1578,3	219	2x2"	2x1"
BNDR904A	333	237,2	79050	50564	43	33			8 x 910	1050,1	146	2x2"	2x1"
BNDR904B	357,47	242,45	74825	47086	43	33			8 x 910	1575,2	219	2x2"	2x1"
BNDR904C	373,59	239,82	70990	44159	43	33			8 x 910	2100,3	291	2x2"	2x1"
BNDR905A	407,83	292,9	98790	63186	44	34			10 x 910	1311,1	182	2x2"	2x1"
BNDR905B	428,11	296,62	93501	58834	44	34			10 x 910	1966,7	273	2x2"	2x1"
BNDR905C	462,82	298,41	88701	55172	44	34			10 x 910	2622,3	364	2x2"	2x1"

Nominal capacities according to R717 Tair=25°C, Tcond=40°C, ΔTsubcool<3K, ΔTsuperheat=25K).

Note: The units are designed for horizontal installation. Vertical installations require special refrigerant circuits.

*See the "General Contents" for more details.

Model	Capacity [kW]		Airflow [m³/h]		Lp [dB(A)]*		Motor (3/400V-50Hz)		Fans	Surface	Tube volume	Conn. Size	
	Δ	Υ	Δ	Υ	Δ	Υ	Δ	Υ	N° x D [mm]	m²	dm³	mm	
												Inlet	Outlet
Ø 1000													
BNDL1002A	336,92	292,53	113817	88855	59	54	P=2200 I=4.2A n=670min-1	P=1500W I=2.7A n=530min-1	4 x 1000	528,2	73	2x2"	2x1"
BNDL1002B	408,01	341,99	104158	80565	59	54			4 x 1000	792,3	110	2x2"	2x1"
BNDL1002C	435,91	355,51	96027	73857	59	54			4 x 1000	1056,4	147	2x2"	2x1"
BNDL1003A	507,45	440	170519	133100	61	56			6 x 1000	789,2	109	2x2"	2x1"
BNDL1003B	606,01	508,9	155971	120625	61	56			6 x 1000	1183,7	164	2x2"	2x1"
BNDL1003C	644,54	527,42	143745	110546	61	56			6 x 1000	1578,3	219	2x2"	2x1"
BNDL1004A	671,75	583,2	227220	177344	62	57			8 x 1000	1050,1	146	2x2"	2x1"
BNDL1004B	796,9	670,99	207783	160684	62	57			8 x 1000	1575,2	219	2x2"	2x1"
BNDL1004C	840,88	692,28	191462	147234	62	57			8 x 1000	2100,3	291	2x2"	2x1"
BNDL1005A	831,77	723,52	283920	221588	63	58			10 x 1000	1311,1	182	2x2"	2x1"
BNDL1005B	1004,59	844,33	259594	200742	63	58	10 x 1000	1966,7	273	2x2"	2x1"		
BNDL1005C	1079,98	881,9	239179	183922	63	58	10 x 1000	2622,3	364	2x2"	2x1"		
BNDQ1002A	260,63	207,89	73547	52212	45	38	P=860W I=4.2A n=430min-1	P=500W I=2.7A n=320min-1	4 x 1000	528,2	73	2x2"	2x1"
BNDQ1002B	290,84	220,76	65728	46010	45	38			4 x 1000	792,3	110	2x2"	2x1"
BNDQ1002C	289,15	214,4	58788	41400	45	38			4 x 1000	1056,4	147	2x2"	2x1"
BNDQ1003A	384,48	307,87	110164	78174	47	40			6 x 1000	789,2	109	2x2"	2x1"
BNDQ1003B	422,5	324,03	98365	68857	47	40			6 x 1000	1183,7	164	2x2"	2x1"
BNDQ1003C	437,75	323,12	87934	61940	47	40			6 x 1000	1578,3	219	2x2"	2x1"
BNDQ1004A	519,62	414,33	146781	104136	48	41			8 x 1000	1050,1	146	2x2"	2x1"
BNDQ1004B	579,72	439,99	131002	91703	48	41			8 x 1000	1575,2	219	2x2"	2x1"
BNDQ1004C	576,28	427,32	117079	82480	48	41			8 x 1000	2100,3	291	2x2"	2x1"
BNDQ1005A	645,16	515,38	183397	130098	49	42			10 x 1000	1311,1	182	2x2"	2x1"
BNDQ1005B	728,25	551,58	163638	114549	49	42	10 x 1000	1966,7	273	2x2"	2x1"		
BNDQ1005C	707,95	528,08	146223	103020	49	42	10 x 1000	2622,3	364	2x2"	2x1"		
BNDR1002A	240,77	175,22	64975	41093	43	34	P=670W I=1.4A n=390min-1	P=330W I=0.67 n=260min-1	4 x 1000	528,2	73	2x2"	2x1"
BNDR1002B	263,51	180,94	57629	36195	43	34			4 x 1000	792,3	110	2x2"	2x1"
BNDR1002C	258,34	171,22	51351	32266	43	34			4 x 1000	1056,4	147	2x2"	2x1"
BNDR1003A	355,83	260,2	97314	61532	45	36			6 x 1000	789,2	109	2x2"	2x1"
BNDR1003B	384,57	267	86235	54160	45	36			6 x 1000	1183,7	164	2x2"	2x1"
BNDR1003C	390,27	257,48	76804	48261	45	36			6 x 1000	1578,3	219	2x2"	2x1"
BNDR1004A	479,99	349,29	129652	81971	46	37			8 x 1000	1050,1	146	2x2"	2x1"
BNDR1004B	525,14	360,55	114841	72125	46	37			8 x 1000	1575,2	219	2x2"	2x1"
BNDR1004C	514,77	341,08	102257	64256	46	37			8 x 1000	2100,3	291	2x2"	2x1"
BNDR1005A	596,4	434,95	161989	102410	47	38			10 x 1000	1311,1	182	2x2"	2x1"
BNDR1005B	659,11	451,6	143446	90090	47	38	10 x 1000	1966,7	273	2x2"	2x1"		
BNDR1005C	633,58	422,89	127710	80250	47	38	10 x 1000	2622,3	364	2x2"	2x1"		

Nominal capacities according to R717 Tair=25°C, Tcond=40°C, ΔTsubcool<3K, ΔTsuperheat=25K).

Note: The units are designed for horizontal installation. Vertical installations require special refrigerant circuits.

*See the "General Contents" for more details.

BCD/BND - Double Fan Row

Drawings

Model	Weight [kg]	Dimensions (mm)					N° feet	
		A	B	C	D	G	V	H
Ø 800								
BCD_802 A	600	3905	3955	3475(V)/3404(H)	-	2290(V)/1220(H)	2	4
BCD_802 B	680	3905	3955	3475(V)/3404(H)	-	2290(V)/1220(H)	2	4
BCD_802 C	760	3905	3955	3475(V)/3404(H)	-	2290(V)/1220(H)	2	4
BCD_803 A	820	5655	5705	5225(V)/5154(H)	-	2290(V)/1220(H)	2	4
BCD_803 B	940	5655	5705	5225(V)/5154(H)	-	2290(V)/1220(H)	2	4
BCD_803 C	1060	5655	5705	5225(V)/5154(H)	-	2290(V)/1220(H)	2	4
BCD_804 A	1040	7405	7455	3475(V)/3404(H)	3500	2290(V)/1220(H)	3	6
BCD_804 B	1200	7405	7455	3475(V)/3404(H)	3500	2290(V)/1220(H)	3	6
BCD_804 C	1360	7405	7455	3475(V)/3404(H)	3500	2290(V)/1220(H)	3	6
BCD_805 A	1260	9155	9205	3475(V)/3404(H)	1775	2290(V)/1220(H)	4	8
BCD_805 B	1460	9155	9205	3475(V)/3404(H)	1775	2290(V)/1220(H)	4	8
BCD_805 C	1660	9155	9205	3475(V)/3404(H)	1775	2290(V)/1220(H)	4	8
BCD_806 A	1480	10905	10955	3475(V)/3404(H)	3525	2290(V)/1220(H)	4	8
BCD_806 B	1720	10905	10955	3475(V)/3404(H)	3525	2290(V)/1220(H)	4	8
BCD_806 C	1960	10905	10955	3475(V)/3404(H)	3525	2290(V)/1220(H)	4	8
Ø 910								
BCD_902 A	790	4605	4655	4175(V)/4104(H)	-	2290(V)/1290(H)	2	4
BCD_902 B	880	4605	4655	4175(V)/4104(H)	-	2290(V)/1290(H)	2	4
BCD_902 C	970	4605	4655	4175(V)/4104(H)	-	2290(V)/1290(H)	2	4
BCD_903 A	1020	6705	6755	6275(V)/6204(H)	-	2290(V)/1290(H)	2	4
BCD_903 B	1160	6705	6755	6275(V)/6204(H)	-	2290(V)/1290(H)	2	4
BCD_903 C	1300	6705	6755	6275(V)/6204(H)	-	2290(V)/1290(H)	2	4
BCD_904 A	1250	8805	8855	4175(V)/4104(H)	4200	2290(V)/1290(H)	3	6
BCD_904 B	1440	8805	8855	4175(V)/4104(H)	4200	2290(V)/1290(H)	3	6
BCD_904 C	1630	8805	8855	4175(V)/4104(H)	4200	2290(V)/1290(H)	3	6
BCD_905 A	1480	10905	10955	4175(V)/4104(H)	2125(V)/2196(H)	2290(V)/1290(H)	4	8
BCD_905 B	1720	10905	10955	4175(V)/4104(H)	2125(V)/2196(H)	2290(V)/1290(H)	4	8
BCD_905 C	1960	10905	10955	4175(V)/4104(H)	2125(V)/2196(H)	2290(V)/1290(H)	4	8
Ø 1000								
BCD_1002 A	790	4605	4655	4175(V)/4104(H)	-	2290(V)/1290(H)	2	4
BCD_1002 B	880	4605	4655	4175(V)/4104(H)	-	2290(V)/1290(H)	2	4
BCD_1002 C	970	4605	4655	4175(V)/4104(H)	-	2290(V)/1290(H)	2	4
BCD_1003 A	1020	6705	6755	6275(V)/6204(H)	-	2290(V)/1290(H)	2	4
BCD_1003 B	1160	6705	6755	6275(V)/6204(H)	-	2290(V)/1290(H)	2	4
BCD_1003 C	1300	6705	6755	6275(V)/6204(H)	-	2290(V)/1290(H)	2	4
BCD_1004 A	1250	8805	8855	4175(V)/4104(H)	4200	2290(V)/1290(H)	3	6
BCD_1004 B	1440	8805	8855	4175(V)/4104(H)	4200	2290(V)/1290(H)	3	6
BCD_1004 C	1630	8805	8855	4175(V)/4104(H)	4200	2290(V)/1290(H)	3	6
BCD_1005 A	1480	10905	10955	4175(V)/4104(H)	2125(V)/2196(H)	2290(V)/1290(H)	4	8
BCD_1005 B	1720	10905	10955	4175(V)/4104(H)	2125(V)/2196(H)	2290(V)/1290(H)	4	8
BCD_1005 C	1960	10905	10955	4175(V)/4104(H)	2125(V)/2196(H)	2290(V)/1290(H)	4	8

Standard feet 500 mm.

We reserve the right to change our technical data without prior notice.

VERTICAL POSITION

HORIZONTAL POSITION

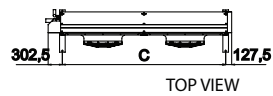
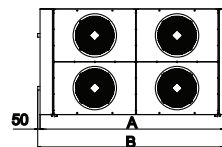
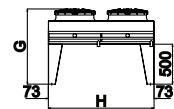
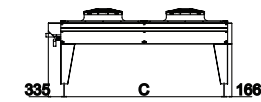
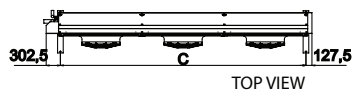
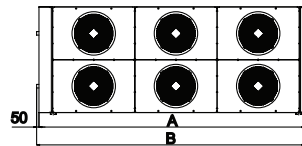
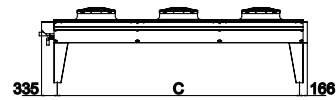
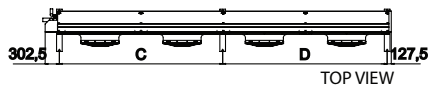
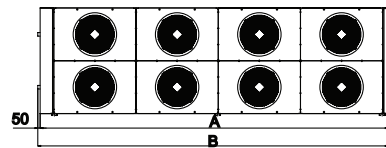
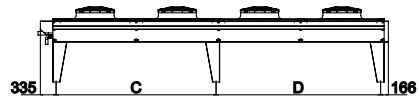
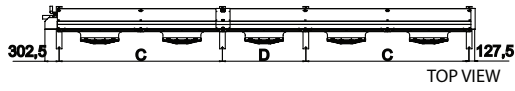
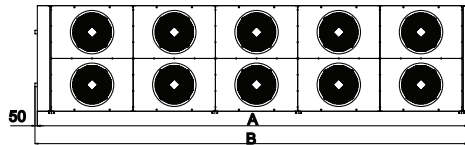
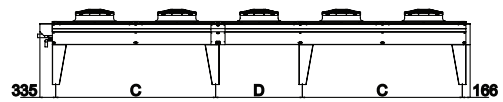
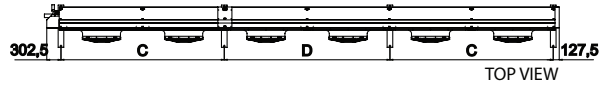
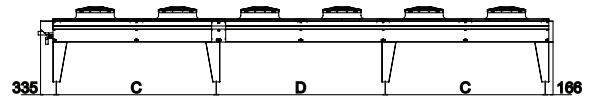
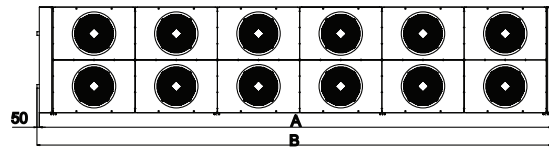

Serie	Weight [Kg]	Dimension (mm)					N°feet
		A	B	C	D	F	
Ø 800							
BND_802 A	630	4015	3404	-	1250	2255	4
BND_802 B	715	4015	3404	-	1250	2255	4
BND_802 C	800	4015	3404	-	1250	2255	4
BND_803 A	860	5765	5154	-	1250	2255	4
BND_803 B	990	5765	5154	-	1250	2255	4
BND_803 C	1120	5765	5154	-	1250	2255	4
BND_804 A	1090	7515	3404	3500	1250	2255	6
BND_804 B	1265	7515	3404	3500	1250	2255	6
BND_804 C	1440	7515	3404	3500	1250	2255	6
BND_805 A	1320	9265	3404	1846	1250	2255	8
BND_805 B	1540	9265	3404	1846	1250	2255	8
BND_805 C	1760	9265	3404	1846	1250	2255	8
BND_806 A	1550	11015	3404	3596	1250	2255	8
BND_806 B	1815	11015	3404	3596	1250	2255	8
BND_806 C	2080	11015	3404	3596	1250	2255	8
Ø 910							
BND_902 A	830	4715	4104	-	1290	2255	4
BND_902 B	930	4715	4104	-	1290	2255	4
BND_902 C	1030	4715	4104	-	1290	2255	4
BND_903 A	1070	6815	6204	-	1290	2255	4
BND_903 B	1225	6815	6204	-	1290	2255	4
BND_903 C	1380	6815	6204	-	1290	2255	4
BND_904 A	1310	8915	4104	4200	1290	2255	6
BND_904 B	1520	8915	4104	4200	1290	2255	6
BND_904 C	1730	8915	4104	4200	1290	2255	6
BND_905 A	1550	11015	4104	2196	1290	2255	8
BND_905 B	1815	11015	4104	2196	1290	2255	8
BND_905 C	2080	11015	4104	2196	1290	2255	8
Ø 1000							
BND_1002 A	830	4715	4104	-	1290	2255	4
BND_1002 B	930	4715	4104	-	1290	2255	4
BND_1002 C	1030	4715	4104	-	1290	2255	4
BND_1003 A	1070	6815	6204	-	1290	2255	4
BND_1003 B	1225	6815	6204	-	1290	2255	4
BND_1003 C	1380	6815	6204	-	1290	2255	4
BND_1004 A	1310	8915	4104	4200	1290	2255	6
BND_1004 B	1520	8915	4104	4200	1290	2255	6
BND_1004 C	1730	8915	4104	4200	1290	2255	6
BND_1005 A	1550	11015	4104	2196	1290	2255	8
BND_1005 B	1815	11015	4104	2196	1290	2255	8
BND_1005 C	2080	11015	4104	2196	1290	2255	8

The information is for the horizontal version with 500mm standard feet.

We reserve the right to change our technical data without prior notice.

HORIZONTAL POSITION

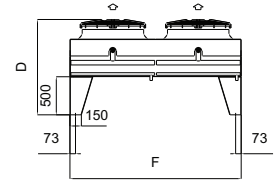
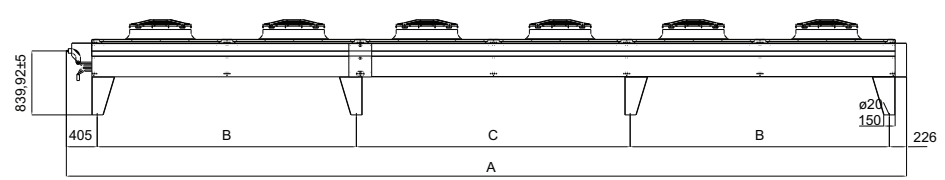
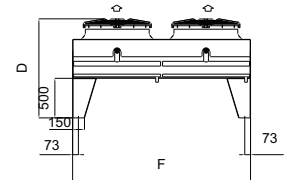
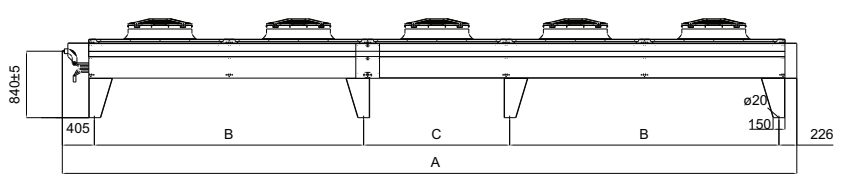
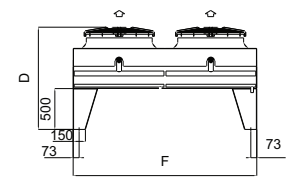
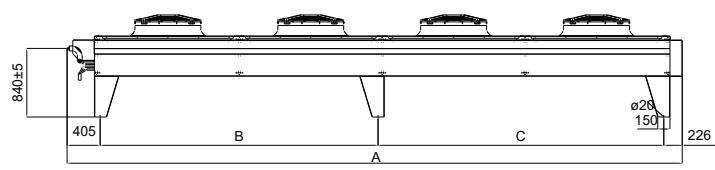
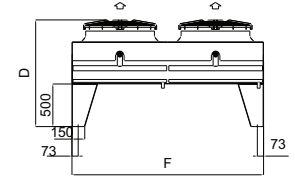
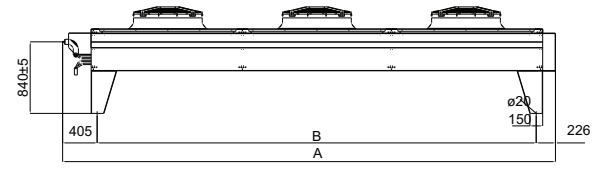
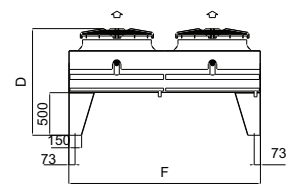
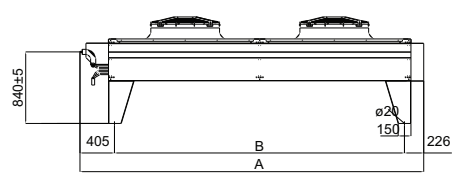

BCD/BND - Double Fan Row

Options

Motor fans



(a) Fan motor 400 V/3ph - 60Hz, IP54: Q/R for Ø 800/910/1000 and also S/L for Ø 800/910
 (b) Fan motor 460 V/3ph - 60Hz, IP54: Q/R for Ø 800/910/1000 and also S/L for Ø 800/910

Model:
 Ø 800 (a,b)
 Ø 910(a,b)
 Ø1000 (a,b)

Local safety switch wired

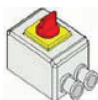

See Electrical Data Page.

Model:
 All Models

Local safety switch EMC

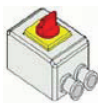

See Electrical Data Page.

Model:
 All Models

Terminal Box

See Electrical Data Page.

Model:
 All Models

Switchboard and cabling		
	<p>Function</p> <p>Switchboard for supply and control of fan motors.</p> <p>A switchboard can supply up to 8 individual motors or 8 paired motors (i.e. max. of 16 motors).</p> <p>Switchboard and cabling are supplied as standard for vertical installation of the unit.</p> <p>If you have different needs, please specify these when placing your order.</p> <p>Operating conditions</p> <p>Type of installation: External wall mounted</p> <p>Protection degree: IP55 door closed</p> <p>Climate: Normal</p> <p>Operating temperature: -10 ÷ +35°C (base) -25 ÷ +50°C (with options)</p> <p>Ambient relative humidity: <95%</p> <p>Altitude: <1000metres above sea level</p> <p>Electrical data</p> <p>Insulating nominal voltage: 690V</p> <p>Operating voltage: 3Ph. 400Vac</p> <p>Frequency: 50Hz</p> <p>Auxiliaries voltage: 24-230V</p> <p>Nominal current: Max 80A</p> <p>Mechanical data</p> <p>Material: Pre-painted galvanized steel</p> <p>Fixing plate: Sheet of steel (min. thickness 15/10 Sendzimir galvanized)</p> <p>Gasket: Polyurethane</p> <p>Door: opening more than 180°.</p> <p>Colour: RAL 7035</p> <p>Cable gland: metric ISO</p>	<p>Model:</p> <p>All Models</p>
Switchboard Options		
	<p>R anti-condensate resistor 230Vac (operating temperature -25 ÷ +35°C)</p> <p>C cooling fan 230Vac (operating temperature -10 ÷ +50°C)</p> <p>F cooling fan + anti-condensate resistor</p>	<p>Model:</p> <p>All Models</p>
Switchboard with Fan Speed control		
	<p>Switchboard and cabling including an electronic fan motor speed controller. This equipment continually checks and regulates the rotation speed of the fan's motor, keeping the condensing pressure within the range or pre-defined values. Constant control of the fan speed is achieved by variation of the electrical supply by phase-cut, as determined by the probe signal. The fan speed controller comes pre-connected to the switchboard. If you have different needs, please specify these when placing your order.</p>	<p>Model:</p> <p>All Models</p>
Switchboard with Fan Step control		
	<p>Switchboard and cabling including an automatic on/off switch that checks and regulates the rotation speed of the fan's motor, keeping the condensing pressure within the range or pre-defined values. Control of the fan speed is achieved by variation of the electrical supply by the ON/OFF device, as determined by the probe signal. The fan step controller comes pre-connected to the switchboard. If you have different needs, please specify these when placing your order.</p>	<p>Model:</p> <p>All Models</p>
Switchboard with Frequency Converter (Inverter)		
	<p>See Electrical Data Page.</p>	<p>Model:</p> <p>All Models</p>
Coil Treatment / Material		
	<p>Thermoguard for industrial or sea coast application.</p> <p>Aluminium fins, pre-coated.</p> <p>Copper fins.</p> <p>Application Use: More information on corrosion prevention can be found in the Miscellaneous section.</p>	<p>Model:</p> <p>All Models</p>

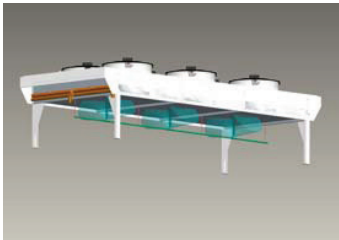
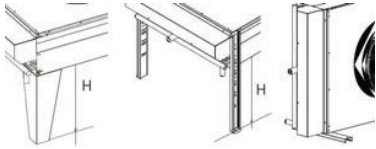
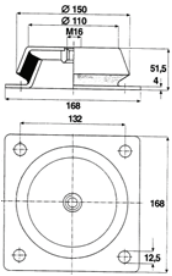
Multi-circuits																
	All models are suitable for multi-circuits, enabling more than one refrigeration system to operate with a single condenser.	Model: All Models														
Sub-cooling circuit																
	Sub-cooling is achieved by the use of an integrated sub-cooling section which harnesses approximately 10% of the coil surface. This provides 6-7°C max. of sub-cooling at the standard rate condition of 15K. The overall effect on the condensing capacity is a reduction of 10%. However, the overall heat rejection inclusive of sub-cooling capacity will only be reduced by 5%.	Model: All Models														
Non-standard fin spacing																
	The standard fin spacing is 2.1mm. Alternative: 2.5mm and 3.2mm.	Model: All Models														
Spray water																
	Consisting of a pipe system with several fitted spraying nozzles that nebulise water in the air suction of the coil. Spray water comes mounted on delivery.	Model: All Models														
Feet																
	H Horizontal Position (500 and 850mm) A Feet adjustable from 350-950cm V Vertical Position	Model: All Models														
Vibration Dampers																
	<table border="1"> <thead> <tr> <th>Type</th> <th>H mm</th> <th>A mm</th> <th>B mm</th> <th>C mm</th> <th>D mm</th> <th>Weight Kg</th> </tr> </thead> <tbody> <tr> <td>Single Row</td> <td>51.5</td> <td>132</td> <td>168</td> <td>M16</td> <td>12.5</td> <td>2.15</td> </tr> </tbody> </table> <p>Nuts and bolts are not included with the dampers.</p>	Type	H mm	A mm	B mm	C mm	D mm	Weight Kg	Single Row	51.5	132	168	M16	12.5	2.15	Model: All Models
Type	H mm	A mm	B mm	C mm	D mm	Weight Kg										
Single Row	51.5	132	168	M16	12.5	2.15										

BCD/BND - Double Fan Row

Electrical Data

Safety Switch

Function

Local safety switch and cabling for each electric fan motor.

General data

Power Supply:

- 400VAC, 50/60Hz
- Max fuse 16A

Number of poles: 3P

Cabinet Material: Plastic Case

Cabinet Colour: Grey (Yellow-Red Knob)

Protection Class: Min IP65

Ambient Temp.: min. -25°C, max. +50°C

Weight: Approx. 0.4Kg

Dimensions

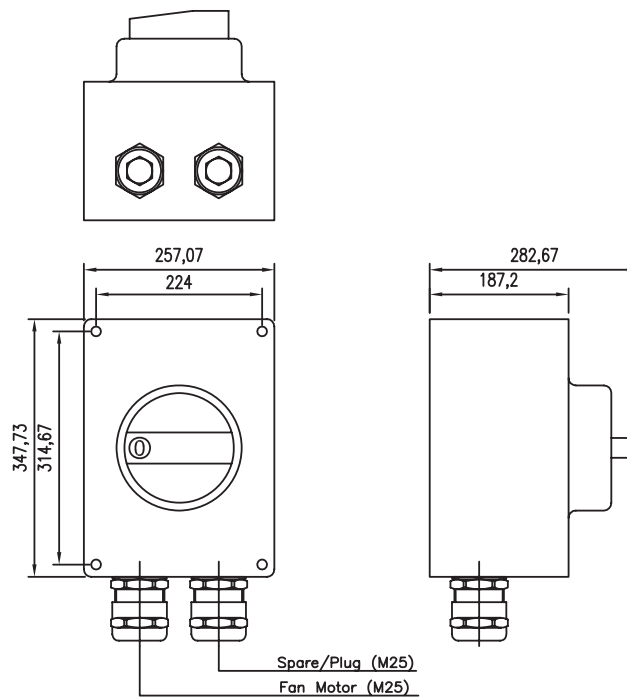

Safety Switch EMC**Function**

Local safety switch and cabling for each electric fan motor.

General data

Power Supply:

- 400VAC, 50/60Hz
- Max fuse 16A

Number of poles: 3P

Cabinet Material: Plastic case with internal copper-painted

Cabinet Colour: Grey (Yellow-Red Knob)

Protection Class: Min IP65

Ambient Temp.: min. -25°C, max. +50°C

Weight: Approx. 0.4Kg

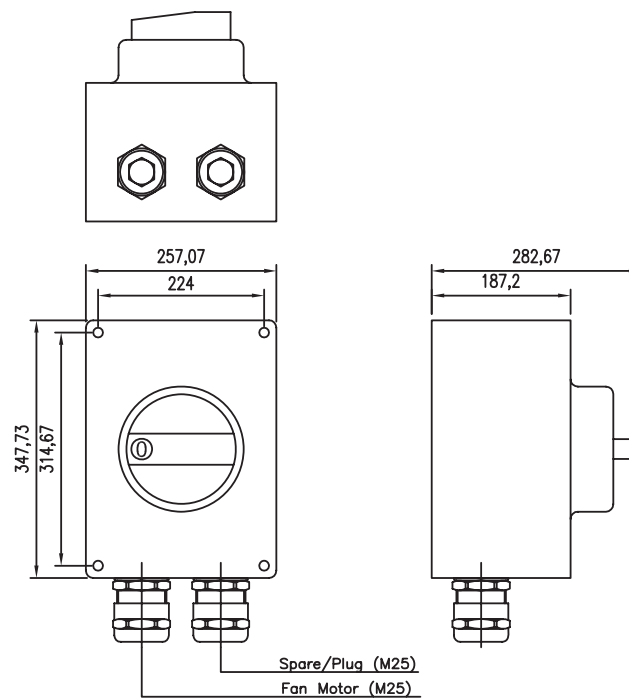
Dimensions

Terminal Box

Function

Connection box for electric fan motor

General data

Material: Plastic
 IP Protection Class: Min RAL 7035
 Colour: Grey RAL 7035
 Insulation Class: II
 Ambient Temp.: min. -40°C, max. +80°C
 Weight: Approx. 0.5Kg.

Dimensions

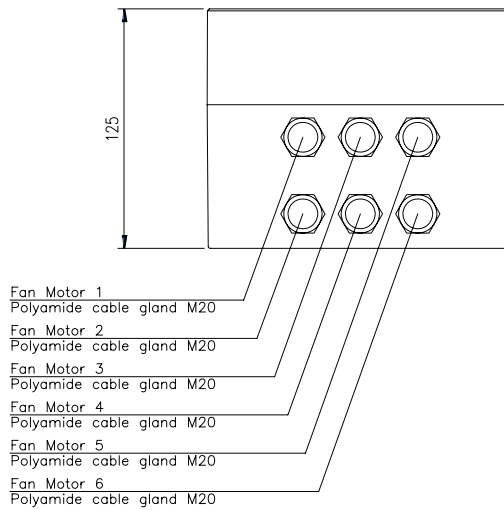
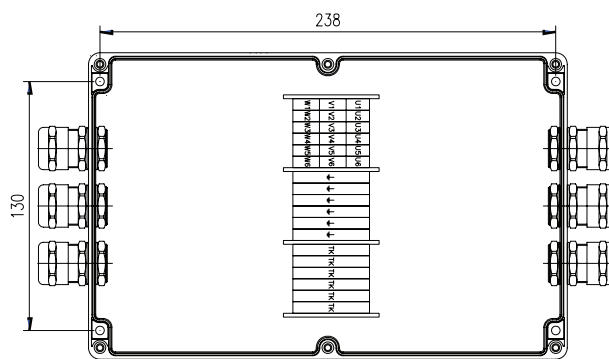

Switch Board (Control Panel)

Function

Basic Version for Horizontal Installation

General data

Cabinet Material: Sheet steel 15/10mm zinc-coated

Internal Plate: Sheet steel 20/10mm zinc-coated

Protection Class: IP 55

Cabinet Colour: RAL 7035, light grey polyester paint

Cabinet Doors: Opening angle 110°

Ambient Temp.:

- min. -10°C, max. +35°C standard
- min. -25°C, max. +35°C with electrical heater
- min. -10°C, max. +50°C with cooling fan
- min. -25°C, max. +50°C with heater and fan

Cables included: Bottom position with cable glands.

Dimensions

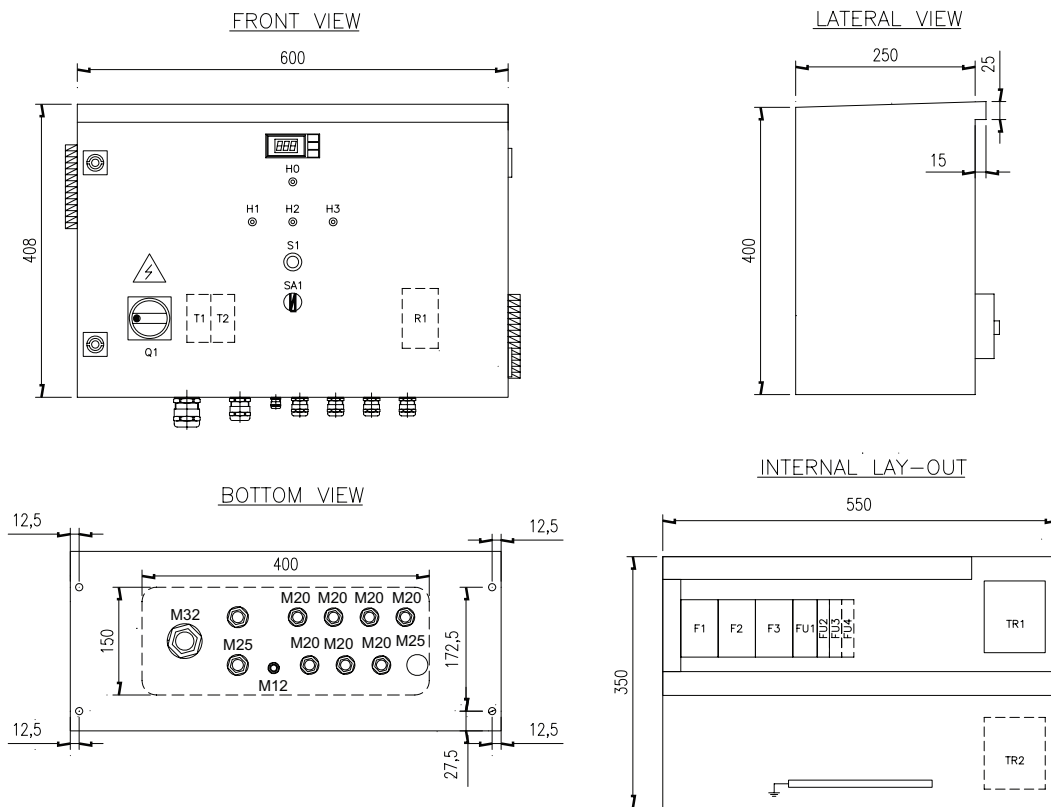

Labels list

- | | |
|-----------------------------------|--|
| H0 VOLTAGE BOARD ON | Q1 MAIN SWITCH |
| H1 FAN MOTOR 1-2 RUNNING (OPTION) | TC1 TEMPERATURE/PRESSURE CONTROLLER (OPTION) |
| H2 FAN MOTOR 3-4 RUNNING (OPTION) | S1 RESET (OPTION) |
| H3 FAN MOTOR 5-6 RUNNING (OPTION) | SA1 MAN - AUT SELECTION (OPTION) |

Electric wiring diagram

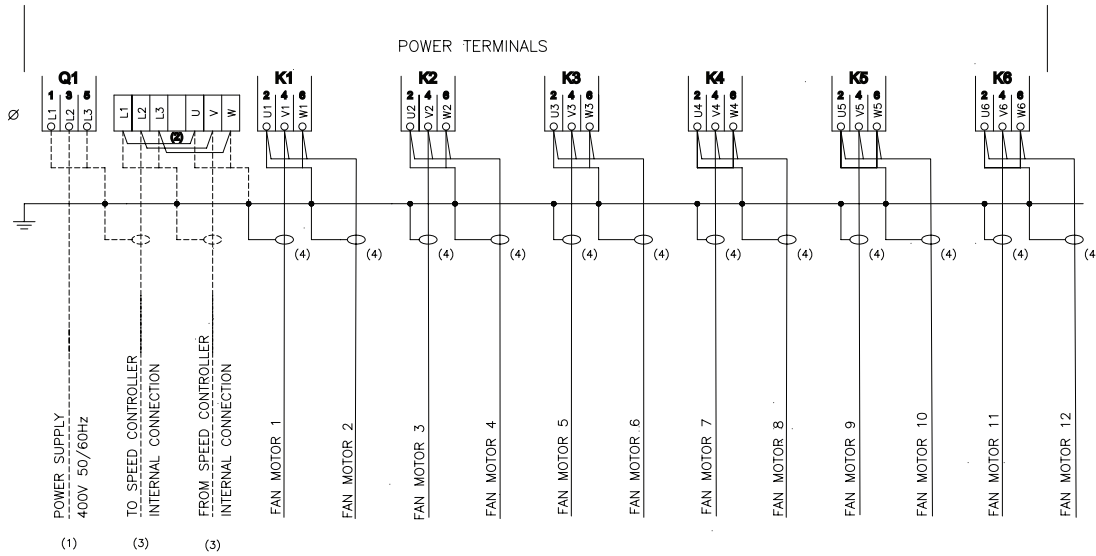

- NOTE:**
- (1) EXTERNAL SHORT CIRCUIT PROTECTION MAX FUSE
 - (2) REMOVE JUMPERS WHEN SPEED CONTROLLER IS ORDERED
 - (3) NOT MOUNTED WHEN FAN SPEED CONTROLLER IS ORDERED
 - (4) SHIELDED CABLE TO BE USED ONLY WHEN EMC CABLING OPTION IS REQUESTED
- CABLE NOT INCLUDED IN ALFA LAVAL DELIVERY
 _____ CABLE INCLUDED IN ALFA LAVAL DELIVERY

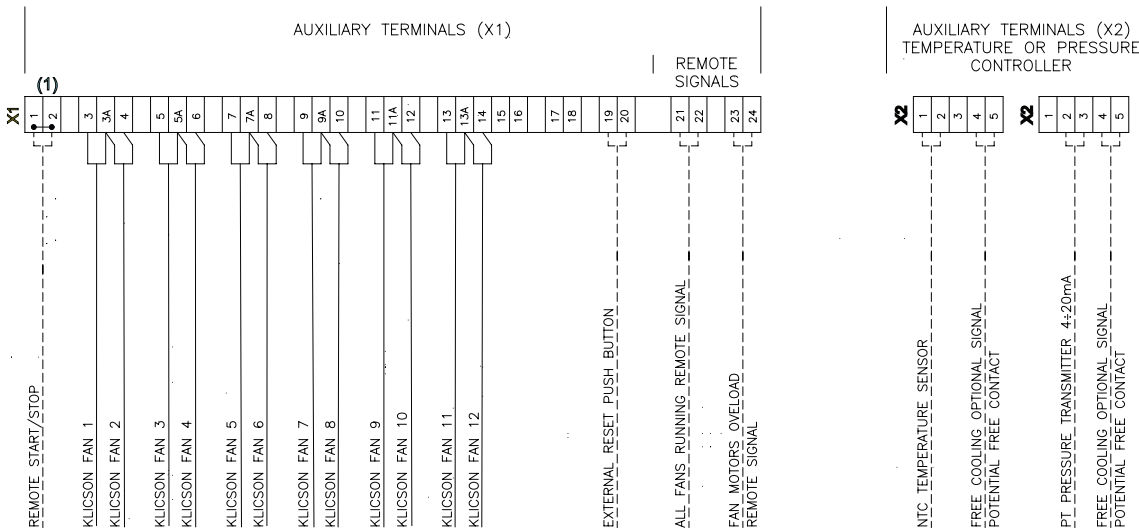

- NOTE:**
- (1) REMOVE JUMPER WHEN USED

Switch Board (Control Panel)

Function

Basic Version for Vertical Installation

General data

Cabinet Material: Sheet steel 15/10mm zinc-coated

Internal Plate: Sheet steel 20/10mm zinc-coated

Protection Class: IP 55

Cabinet Colour: RAL 7035, light grey polyester paint

Cabinet Doors: Opening angle 110°

Ambient Temp.:

- min. -10°C, max. +35°C standard
- min. -25°C, max. +35°C with electrical heater
- min. -10°C, max. +50°C with cooling fan
- min. -25°C, max. +50°C with heater and fan

Cables included: Bottom position with cable glands.

Dimensions

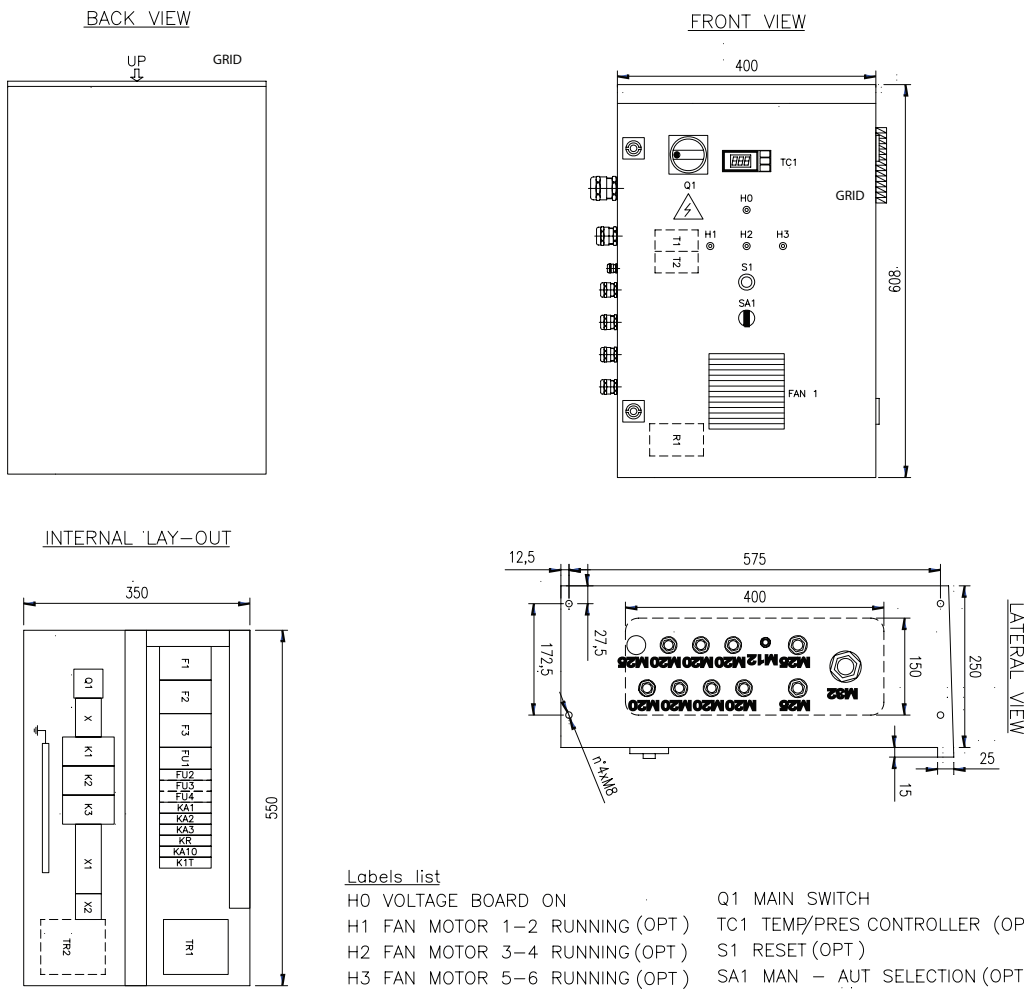

Labels list

- | | |
|--------------------------------|--------------------------------|
| H0 VOLTAGE BOARD ON | Q1 MAIN SWITCH |
| H1 FAN MOTOR 1-2 RUNNING (OPT) | TC1 TEMP/PRES CONTROLLER (OPT) |
| H2 FAN MOTOR 3-4 RUNNING (OPT) | S1 RESET (OPT) |
| H3 FAN MOTOR 5-6 RUNNING (OPT) | SA1 MAN - AUT SELECTION (OPT) |

Electric wiring diagram

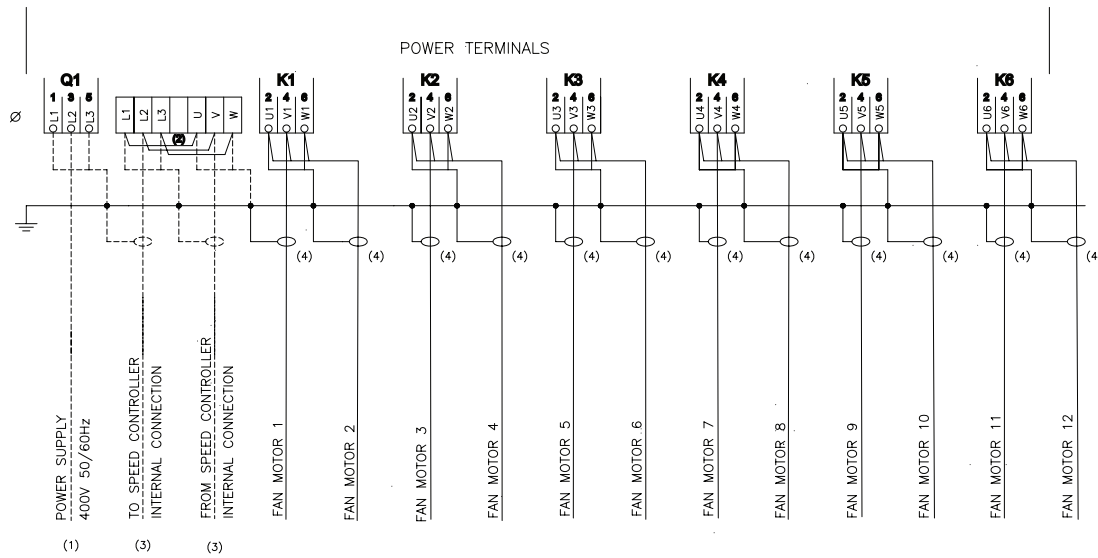

- NOTE:**
- (1) EXTERNAL SHORT CIRCUIT PROTECTION MAX FUSE
 - (2) REMOVE JUMPERS WHEN SPEED CONTROLLER IS ORDERED
 - (3) NOT MOUNTED WHEN FAN SPEED CONTROLLER IS ORDERED
 - (4) SHIELDED CABLE TO BE USED ONLY WHEN EMC CABLING OPTION IS REQUESTED
- CABLE NOT INCLUDED IN ALFA LAVAL DELIVERY
 _____ CABLE INCLUDED IN ALFA LAVAL DELIVERY

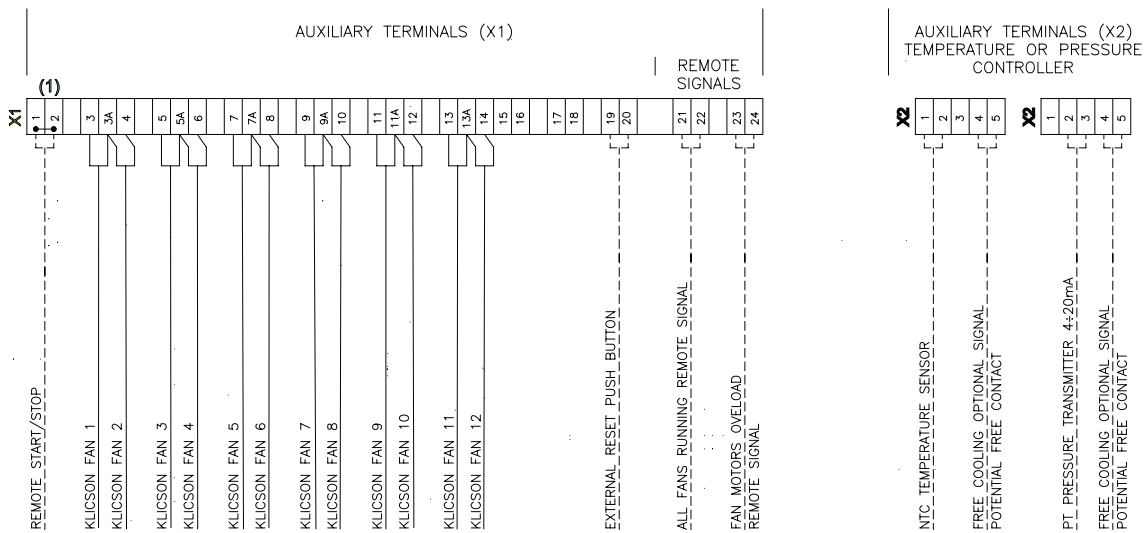

- NOTE:**
- (1) REMOVE JUMPER WHEN USED

Current Distribution

Function

Current distributors are available as optional accessories. Numerous fans can be connected. In combination with Fcontrol frequency inverters, we can deliver the current distribution with both main switch and bypass function. Features: The current distributor is equipped with plastic housing IP54 and motor protection units STDT16E with status signal contacts ZB. It is possible to lock the motor protection units with a padlock and use them as repair switches. Fans are directly connected to the motor protection units. Line protection is guaranteed through the integrated short-circuit release. Terminals for supplying the controller output are also integrated. The current distributors are suitable for external mounting (e.g. direct mounting at refrigeration units). It's easy to see the switch position of the motor protection units through the coloured, transparent plastic door.

General data

Current distributor with main switch and bypass function:

- The controller is supplied by the current distributor
- Main switch: 100% - 0 -1
- In position 100%, the connection to the controller output is switched off. This version is for Fcontrol frequency inverters .
- Rated current: Up to 80A

Dimensions

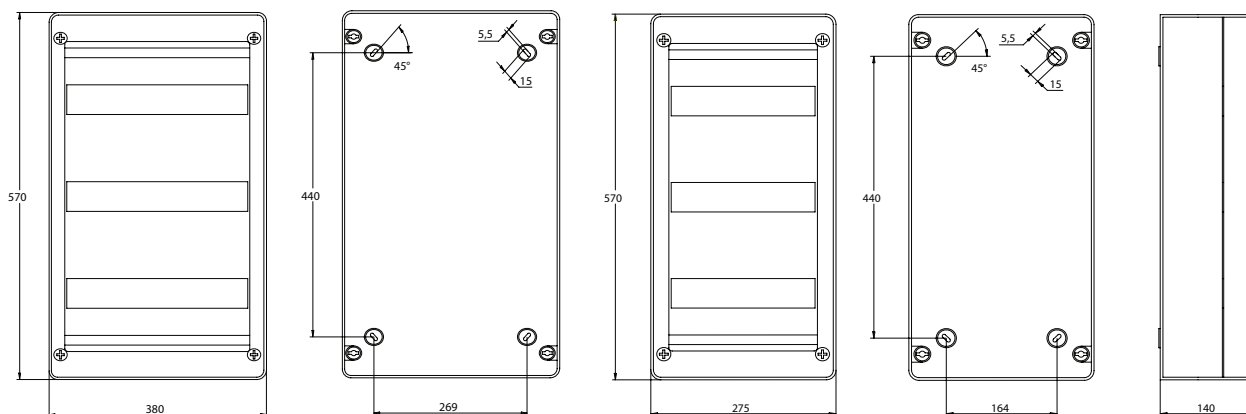

Electric wiring diagram

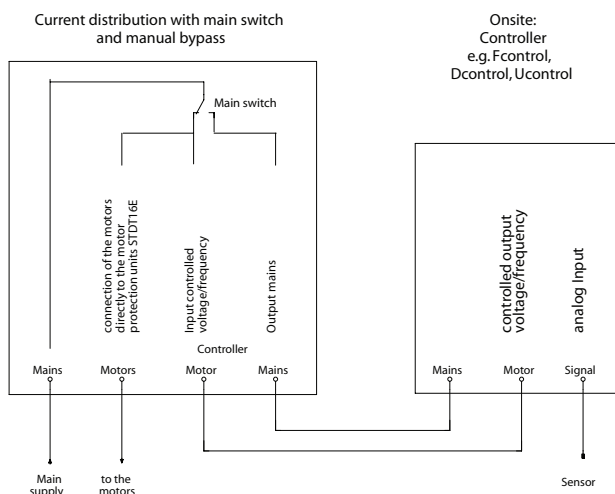

Frequency Converter (Inverter)

Function

Frequency inverter (incl. sine filter) for 3~ motors. Universal controller for refrigeration and air conditioning line input 3~ 208-480V, housing IP54, internal display.

- Speed controller with manual adjustment of output voltage at the unit or via external signal, 2-step operation;
- Temperature control for liquid coolers;
- Pressure control refrigeration (input for refrigerant) for: condensers, dual-circuit condensers;

General data

Equipment/Function

- Integrated SINEFILTER between phase to phase and phase to earth.
- Absolute parallel operation of fans, with no risk of damage to the motor. **Screened motor cables are not required.**
- Integrated process controller (PID free programmable).
- LCD multifunction display with plain language text.
- 2x Analogue Input (0-10 V, 0-20 mA, 4-20 mA, temperature sensor type TF):
 - Analogue 1 for setting of sensor signal.
 - Analogue 2 programmable function for: external set-point, difference value to sensor 1, comparison value (dual-circuit condenser), averaging, and setpoint lowering according to outdoor temperature.
- 1x output 0-10V, programmable function: Constant voltage, proportional modulation, proportional input signal, group control, controller 2.
- 2x digital inputs, programmable function: enable (on / off), external fault, limit output, input 1/2, set-point 1/2, setting internal / external, automatic control / speed manual, reverse control function ("heating" / "cooling"), reset, setting max. speed.
- 2x relay outputs, programmable function: operating indication, fault indication, external fault from digital input, limit modulation, limit input signal, limit offset (deviation actual value setpoint), group control .
- Total motor protection using thermocontact / thermistor connection.
- Interface system with RS485 Interface (MODBUS) or LON® is another alternative option.

Technical data

- Line voltage 3~ 208 BND_480V (-15% / +10%), 50/60Hz.

Rated current*/A	4	8	13	18	22	32	40
Max. line fuse/A	10	10	16	20	25	35	50
Max. heat dissipation*/W	130	210	350	440	540	950	1.100
Weight/Kg	8.8	9.0	22.8	25.4	28.1	29.5	31.8

*at line voltage 400V / 50Hz (for FXDM40A rated current - only possible for fans with $\cos \phi < 0.8$).

- Maximum output frequency 100Hz (for FXDM40, max. 60Hz).
- Clock frequency 16 kHz.
- Max. permissible ambient temperature 40°C (up to 55°C with derating).
- Voltage supply for sensors +24V ±20% (I_{max.} 120 mA).
- Permissible rel. humidity 85% with no condensation .
- Interference emission EN 61000-6-3 1 (unshielded motor cable).
- Interference immunity EN 61000-6-2.

Settings

- Quick start-up with pre-programming modes.
- Set-point 1, set-point 2, manual mode.
- Min. and max. speed, speed limitation e.g. for night operation.
- Group control (via relay or 0-10V signal output).
- Limits: Modulation, input signal, offset (deviation set to actual value).
- Set protection, save user settings.
- Readout events memory (checking the fault log).
- Masking up to 3 settable speed ranges.
- Minimum rate of air on / off.
- Edge frequency, max. frequency / voltage, start voltage.
- U/f characteristics: quadratic or linear.
- Menu language: English, German, Italian, Swedish, etc.
- Inverting: Inputs analogue and digital, analogue out, relays.

BCD/BND - Double Fan Row

Code description

Code No.

BCD/BND	1 S	2 80	3 2	4 A
---------	--------	---------	--------	--------

1) Type of noise level (number of dB(A) to reduce compared with "base" version)

	Turbo noise level	Standard noise level	Low noise level	Quiet noise level	Residential noise level
	T	S*	L*	Q*	R*
Fan diameter Ø 800mm	-	base	-7	-16	-20
Fan diameter Ø 910 mm	base	-2	-9	-19	-20
Fan diameter Ø 1 000 mm	-	-	base	-14	-16

2) Fan diameter Ø

80	800 mm
90	910 mm
100	1 000 mm

3) Number of Fans (* available in this version)

1	Ø 800, 910 and 1000mm fan
2	
3	
4	
5	Ø 800mm fan only

4) Number of coil rows

A	2
B	3
C	4

General Alfa Select Air Legend

Description 1		Description 2	
D	D fan cabling (three phase)	BSFT	Basic Switch Board + Speed Control Temp. + Signal
Y	Y fan cabling (three phase)	BI	Basic Switch Board + Frequency Converter (Inverter)
D/Y	D/Y fan cabling (three phase), single speed fan motor	BSI	Basic Switch Board + Frequency Converter (Inverter) + Signal
S	Single phase	C	Switch Board + Cooling fan
P	Packaged on a pallet	R	Switch Board + Resistor
CR	Packaged in a crate	F	Switch Board + Cooling fan + Resistor
BO	Packaged in a box	PT	Ammonia pump top
Feet	Feet-mounted	PB	Ammonia pump bottom
SW	Safety Switch	AL	Aluminium casing
CB	Terminal Box	SS	Stainless Steel casing
B	Basic Switch Board	AP	Pre-painted Aluminium casing
BS	Basic Switch Board + Signal	PL	Plastic casing
BP	Basic Switch Board + Step Control Pressure	E	Electrical defrost
PT	Basic Switch Board + Step Control Temperature	LE	Low Electrical defrost
BSP	Basic Switch Board + Step Control Pressure + Signal	A	Air Defrost
BST	Basic Switch Board + Step Control Temp. + Signal	HG	Hot Gas Defrost
BFP	Basic Switch Board + Speed Control Pressure	HG+E	Hot Gas Defrost + Electrical Defrost on drip tray
BFT	Basic Switch Board + Speed Control Temperature	W	Water Defrost
BSFP	Basic Switch Board + Speed Control Pres. + Signal	W+E	Water Defrost + Electrical Defrost on drip tray
AL	Aluminium fin	AL	Aluminium fin
CU	Copper fin	CU	Copper fin
PR	Pre-coated fin	PR	Pre-coated fin
SS	Stainless steel tube	SS	Stainless steel tube
TH	Thermoguard treatment	TH	Thermoguard treatment
CF	Cataphoresis treatment	CF	Cataphoresis treatment
SC	Sub-cooling circuit	SC	Sub-cooling circuit
KW	Spray water kit	KW	Spray water kit
FL	Flanges	FL	Flanges
FH	Fan ring heater	FH	Fan ring heater
IS	Insulated Drip Tray	IS	Insulated Drip Tray
RH	Reheating coil	RH	Reheating coil
SR	Air socket adapter ring	SR	Air socket adapter ring
CW	Air throw fan cowl	CW	Air throw fan cowl
ER	120° elbow reducer	ER	120° elbow reducer
HN	Hinged fan cowl	HN	Hinged fan cowl

Note: Valid for the entire product range.

AlfaGreen Condensers

General Contents

General Features

All products are designed to satisfy both commercial and industrial refrigeration, air conditioning, and retail refrigeration. All axial condensers are available in the following versions:

- Vertical installation (V)
- Horizontal installation (H)
- Most common refrigerant HFC, such as R404A, R507C, R407C, R134a

Relative footprint, low consumption and low noise levels are the keys to this series' success.

Certifications and reliability

All Air Cooled condensers are guaranteed by Eurovent "Certify All". Alfa Laval quality systems fully comply with ISO 9001, and all of our products are manufactured in strict accordance with CE regulations.

Capacity

The standard conditions are in accordance with EN 327 (R404A, T. air = 25°C, T.cond.= 40°C, ΔT sub-cool < 3K, ΔT superheat = 25K).

How to work out the condenser's capacity:

$$Q_c = Q_f \times Fr \times F1 \times F2 \times F3 \times F4 \times F5 \times F6$$

Qc = Condenser capacity

Qf = Evaporator capacity

Fr = Condensing Temp (Tc) and evaporating Temp factor. (Te).

F1 = Compressor factor

F2 = Refrigerant factor

F3 = ΔT factor (15/ΔT)

F4 = Altitude factor

F5 = Fin material

F6 = Ambient temperature factor

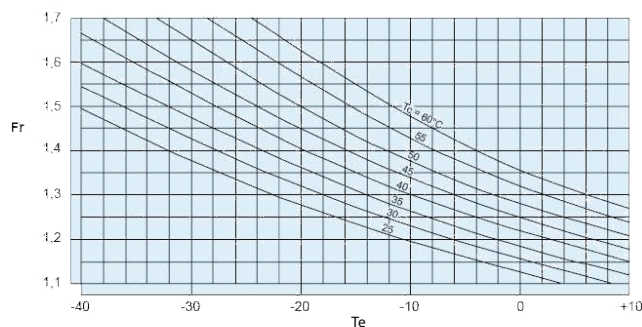

Compressor	Open	Semi-hermetic	Hermetic
F1	1	1,08	1,14

Refrigerant	R507A	R404A	R134a	R22	R407C
F2	1	1	0,93	0,96	0,87

Altitude (m)	0	500	1000	1500	2000
F4	1	1,028	1,06	1,09	1,12

Fin material	Al	Al Prv	Cu
F5	1	1,03	0,97

Ambient Temp.	15	20	25	30	35
F6	0,975	0,988	1,00	1,013	1,026

Tube Protection



Due to the thermal expansion of the copper pipes, all metal sheets are equipped with an aluminium plate with collars. This plate supports the tube and therefore the pipes must not come into contact with the metal sheets. With this solution, the vibrations and thermal expansion are absorbed by the aluminium sheet. Leaks caused by friction cannot occur. The rigidity of the coil is sustained effectively.

Energy Efficiency Class

Energy efficiency class of air cooled condensers		
Class	Energy consumption	R
A	Extremely low	R>110
B	Very low	70≤R<110
C	Low	45≤R<70
D	Medium	30≤R<45
E	High	R<30

R = Condenser capacity (ΔT15K) / motor power consumption.

Test and cleaning

The coils are cleaned and dehydrated in order to remove any traces of oil.

Each heat exchanger undergoes a pressure and leak test with dry air at 34 bar, before being supplied with a nitrogen pre-charge.



Sound Data

The sound pressure level is based on the calculation (according to EN 13487) of the sound pressure level on the surface of a cuboid area which is at a 10 metre distance and is parallel to the reference envelope of the sound source. (Standard sound pressure level; annex C EN 13487)

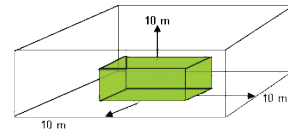

Sound pressure correction for distances other than 10 metres.

Distance (m)	2	3	4	5	7	10	15	20	30	40	50	60	80
Correction dB(A)	11	8,5	7	5	2,5	0	-3	-5,5	-9	-11	-12	-14	-16

Sound pressure level for several fans at nominal speed rating.

N° units	2	3	4	5	6	7	8	9	10
dB(A)	3	5	6	7	8	8,5	9	9,5	10

To calculate the sound pressure level, take the sound power of the individual fans according to their position, and calculate the sound propagation taking into consideration the local and ambient conditions. Speed change, start-up and control noises are not taken into account.

Fan Model	Speed rpm		Total Lw dB(A)		LW octave band spectrum dB(A)															
					63Hz		125Hz		250Hz		500Hz		1 000Hz		2 000Hz		4 000Hz		8 000Hz	
Connection	Δ	Y	Δ	Y	Δ	Y	Δ	Y	Δ	Y	Δ	Y	Δ	Y	Δ	Y	Δ	Y	Δ	Y
400 S	1440	-	69	-	-	-	64	-	63	-	62	-	57	-	57	-	52	-	44	-
400 L	940	-	59	-	-	-	38	-	49	-	50	-	49	-	47	-	45	-	36	-
500 S	1310	1000	77	71	-	-	48	54	54	57	66	58	69	64	66	60	60	52	50	42
500 L	900	640	68	61	-	-	46	39	49	46	55	49	60	53	57	48	49	41	38	30
500 Q	670	520	60	56	-	-	38	39	46	43	49	45	52	48	48	42	40	34	30	28
630 S	1340	1070	90	84	-	-	68	66	76	72	78	74	83	77	81	76	78	72	70	65
630 L	900	690	77	71	-	-	62	55	69	63	72	65	75	68	72	63	64	56	58	50
630 Q	650	480	70	62	-	-	51	48	60	55	63	58	65	59	60	53	53	47	46	45
630 R	430	330	60	54	-	-	46	45	53	47	54	51	53	49	48	43	43	40	42	41
800 S	880	660	83	76	-	-	69	56	67	62	74	69	78	74	79	72	72	64	62	54
800 L	680	530	76	71	-	-	57	49	62	57	69	63	74	68	72	63	65	55	55	45
800 Q	440	340	66	60	-	-	47	42	57	48	59	54	63	56	58	51	50	43	39	34
800 R	380	240	63	52	-	-	47	42	54	44	57	47	59	48	55	42	47	34	35	26
910 S	860	660	85	79	-	-	72	70	79	73	82	76	84	79	82	76	79	73	73	66
910 L	640	440	78	70	-	-	68	62	73	68	76	70	77	70	76	70	73	67	66	60
910 Q	440	330	68	62	-	-	57	49	61	58	64	57	67	60	61	53	52	45	43	35
910 R	390	250	65	53	-	-	56	46	59	45	59	46	61	49	56	44	48	35	38	22

Guarantee

All our products are protected under warranty for 18 months from the shipping date. If a defect should occur within the warranty period, please return the equipment or part to our factory free of charge where we will repair or replace the goods, depending on what is required. Unfortunately, We cannot take responsibility for damage caused by the misuse or incorrect installation of our products. The brochure is subject to technical changes without prior notice

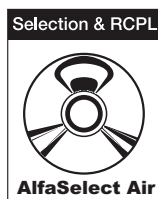

We recommend that you use the Alfa Select Air software for a precise thermal and mechanical design.



AC - Single Fan Row

Product description

Application

The Alfa Laval Condenser can be used in refrigeration and air conditioning equipment.

Standard design

Coil

This innovative heat exchanger gives excellent heat transfer with minimal refrigerant costs, thanks to the new fin corrugation, developed by Alfa Laval, combined with advanced cross-fin tubes. In the standard execution, heat exchanger manufactured from copper tubes and aluminum fins with spacing 2.1 mm. Each heat exchanger undergoes a pressure and leaking test with dry air at 34bar, and finally supplied with a nitrogen pre-charge.

Casing

Casework is made from galvanized steel sheets painted with an epoxy finish, RAL 9002. New frame design provides greater rigidity for heavy applications. The new system protects the heat exchanger tubes completely during transportation and against vibration and thermal expansion while in operation. Support manufactured in galvanized steel, with optimised length to permit uniform air suction in the coil.

Benefits

- Low power consumption fan motor
- Low noise level
- Wide range of capacities and solutions.
- Eurovent certified

Options

- Fan Motor 1ph 230V-50/60Hz (diameter 400, 500 and 630mm)
- Fan Motor 460/3ph-60Hz IP54
- Local safety switch wired
- Local safety switch EMC
- Terminal Box for electric power connection
- Fan speed control 230V-1ph and 400V-3ph
- Switchboard with fan step control and cabling
- Switchboard with fan speed control and cabling
- Thermoguard Treatment
- Pre-coated aluminium fins
- Copper fins
- Multi-circuits: total capacity split in multiple compressor lines
- Sub-cooling circuit
- Non-standard fin spacing (2.5 and 3.2mm)
- Vibration dampers



Fans

High efficiency fans with low power consumption are used. Five different fan diameters are available: 400, 500, 630, 800 and 910mm with a 400V-50/60Hz three-phase motor. The motors come with external rotors which comply with VDE 0530/12.84. Protection class IP 54 according to DIN 40050. Integrated thermo contacts provide reliable protection against any thermal overloads. New bell mouths optimise the performance of the fan motors and minimise the noise level. Axial Condensers (AC) are available in 4 fan motor noise levels: (S) standard, (L) low, (Q) quiet and (R) residential.

For air temperatures lower than +20°C, the full load current (FLC) can be calculated using the correction factor table. The overload protectors should have a 20% margin to accommodate fan motor supplier variations.

T [°C]	20	10	0	-10	-15	-20	-25	-30
Fc	1	1,04	1,08	1,12	1,14	1,16	1,18	1,2

Model	Capacity [kW]		Capacity [kW] 1/230V 50Hz	Airflow [m³/h]		Lp [dB(A)]*		Motor (3/400V-50Hz)		Motor (1/230V-50Hz)	Fans	Sur-face	Tube vol-ume	Conn.	
	Δ	Y	kW	Δ	Y	Δ	Y	Δ	Y		N° x D [mm]	m²	dm³	mm	
				Inlet	Outlet										
Ø 400															
ACS401A	8,9	-	7,9	3857	-	42	-	P=260W I _n =0.5A n=1340min ⁻¹	-	P=190W I _n =0.8A n=1430min ⁻¹	1x400	12,9	2	14	12
ACS401B	12,8	-	11,2	3457	-	42	-				1x400	19,3	3	16	14
ACS402A	18,0	-	16,0	7714	-	45	-				2x400	25,8	4	20	18
ACS402B	25,7	-	22,6	6915	-	45	-				2x400	38,6	6	22	20
ACS403A	27,0	-	23,9	11571	-	47	-				3x400	38,6	6,5	24	22
ACS403B	38,7	-	34,0	10382	-	47	-	3x400	58	9	28	22			
ACL401A	-	8,4	7,6	-	2608	-	35	-	P=170W I _n =0.3A n=975min ⁻¹	P=130W I _n =0.6A n=940min ⁻¹	1x400	12,9	2	14	12
ACL401B	-	9,2	8,4	-	2273	-	35				1x400	19,3	3	16	14
ACL402A	-	17,0	15,3	-	5221	-	38				2x400	25,8	4	20	18
ACL402B	-	18,7	16,9	-	4550	-	38				2x400	38,6	6	22	20
ACL403A	-	25,4	22,9	-	7824	-	40				3x400	38,6	6,5	24	22
ACL403B	-	28,0	25,3	-	6819	-	40	3x400	58	9	28	22			
Ø 500															
ACS501A	22,7	19,1	21,5	8085	6139	44	38	P=780W I _n =1.35A n=1310min ⁻¹	P=550W I _n =0.94A n=1000min ⁻¹	P=770W I _n =3.4A n=1210min ⁻¹	1x500	28,1	5	22	20
ACS501B	27,1	21,8	25,4	7533	5601	44	38				1x500	42,2	7	24	22
ACS501C	29,3	22,9	27,3	7043	5161	44	38				1x500	56,2	9	24	22
ACS502A	45,8	38,4	43,4	16171	12277	47	41				2x500	56,2	9	35	28
ACS502B	54,0	43,6	50,7	15065	11203	47	41				2x500	84,3	13	35	28
ACS502C	59,1	46,2	55,0	14087	10321	47	41				2x500	112,4	17	35	28
ACS503A	69,1	57,8	65,3	24256	18416	49	43				3x500	84,3	14	42	35
ACS503B	81,4	65,5	76,3	22598	16804	49	43				3x500	126,5	20	42	35
ACS503C	88,6	69,2	82,5	21130	15482	49	43				3x500	168,7	26	42	35
ACS504B	109,0	87,7	102,2	30130	22406	50	44				4x500	168,7	26	48	42
ACS504C	118,6	92,5	110,4	28173	20643	50	44	4x500	224,9	34	48	42			
ACL501A	17,5	13,8	17,1	5369	3853	39	37	P=320W I _n =0.74A n=900min ⁻¹	P=200W I _n =0.41A n=640min ⁻¹	P=290W I _n =1.25A n=890min ⁻¹	1x500	28,1	5	22	20
ACL501B	19,9	14,9	19,3	4987	3491	39	37				1x500	42,2	7	24	22
ACL501C	21,0	15,3	20,4	4645	3204	39	37				1x500	56,2	9	24	22
ACL502A	35,0	27,6	34,2	10738	7707	42	40				2x500	56,2	9	35	28
ACL502B	39,9	29,9	38,7	9973	6982	42	40				2x500	84,3	13	35	28
ACL502C	42,3	30,6	40,9	9291	6407	42	40				2x500	112,4	17	35	28
ACL503A	52,7	41,5	51,5	16108	11560	44	42				3x500	84,3	14	42	35
ACL503B	59,9	44,9	58,2	14960	10473	44	42				3x500	126,5	20	42	35
ACL503C	63,4	45,9	61,4	13936	9611	44	42				3x500	168,7	26	42	35
ACL504B	80,1	60,0	77,8	19946	13963	45	43				4x500	168,7	26	48	42
ACL504C	84,7	61,3	82,0	18582	12814	45	43	4x500	224,9	34	48	42			
ACQ501A	13,91	11,7	13,3	3901	3094	29	25	P=140W I _n =0.33A n=670min ⁻¹	P=90W I _n =0.17A n=520min ⁻¹	P=140W I _n =0.65A n=650min ⁻¹	1x500	28,1	5	22	20
ACQ501B	15,1	12,4	14,4	3585	2818	29	25				1x500	42,2	7	24	22
ACQ501C	15,7	12,7	15,0	3315	2595	29	25				1x500	56,2	9	24	22
ACQ502A	27,7	23,4	26,5	7802	6187	32	28				2x500	56,2	9	35	28
ACQ502B	30,3	24,8	28,9	7171	5636	32	28				2x500	84,3	13	35	28
ACQ502C	31,4	25,2	29,9	6629	5189	32	28				2x500	112,4	17	35	28
ACQ503A	41,9	35,2	40,0	11703	9281	34	30				3x500	84,3	14	42	35
ACQ503B	45,5	37,3	43,4	10756	8453	34	30				3x500	126,5	20	42	35
ACQ503C	46,8	37,7	44,7	9944	7784	34	30				3x500	168,7	26	42	35
ACQ504B	60,7	49,7	57,9	14342	11271	35	31				4x500	168,7	26	48	42
ACQ504C	61,5	49,8	58,8	13259	10378	35	31	4x500	224,9	34	48	42			

Nominal capacities according to standard ENV327(R404A Tair=25°C, Tcond=40°C, ΔTsubcool<3K, ΔTsuperheat=25K).

* See the "General Contents" for more details.

Model	Capacity [kW]		Capacity [kW] 1/230V 50Hz	Airflow [m³/h]		Lp [dB(A)]*		Motor (3/400V-50Hz)		Motor (1/230V-50Hz)	Fans N° x D [mm]	Surface m²	Tube volume dm³	Conn.	
	Δ	Y		Δ	Y	Δ	Y	Δ	Y					mm Inlet Outlet	
Ø 630															
ACS632A	71,8	64,1	-	31900	25800	62	56	P=1900W I _n =3.2A n=1340min ⁻¹	P=1350W I _n =2.2A n=1070min ⁻¹	-	2x630	177	17	35	28
ACS632B	93,6	81,8	-	30500	24400	62	56				2x630	265,5	24,7	42	28
ACS632C	105,5	90,4	-	29100	23200	62	56				2x630	353,9	33	42	28
ACS633A	111,8	100,2	-	48000	38800	64	58				3x630	267,3	25,5	42	28
ACS633B	141,2	123,2	-	45800	36700	64	58				3x630	400,9	37	54	35
ACS633C	159,1	135,9	-	43700	34900	64	58				3x630	534,5	49,5	54	35
ACS634A	144,8	129,2	-	64000	51700	65	59				4x630	357,6	34	54	42
ACS634B	188,7	164,7	-	61100	49000	65	59				4x630	536,3	49	54	42
ACS634C	205,2	175,2	-	58400	46500	65	59	4x630	715,1	65	60	48			
ACL632A	57,2	51,0	57,1	19700	16300	49	43	P=690W I _n =1.25 n=900min ⁻¹	P=480W I _n =0.78A n=690min ⁻¹	P=780W I _n =3.5A n=900min ⁻¹	2x630	177	17	35	28
ACL632B	69,3	60,2	69,1	18900	15400	49	43				2x630	265,5	24,7	42	28
ACL632C	75,5	63,9	75,0	18200	14600	49	43				2x630	353,9	33	42	28
ACL633A	86,0	76,7	85,9	29600	24500	51	45				3x630	267,3	25,5	42	28
ACL633B	102,6	89,6	102,2	28400	23200	51	45				3x630	400,9	37	54	35
ACL633C	113,9	96,4	113,2	27300	22000	51	45				3x630	534,5	49,5	54	35
ACL634A	113,7	102,1	113,6	39400	32600	52	46				4x630	357,6	34	54	42
ACL634B	138,8	120,7	138,3	37900	30900	52	46				4x630	536,3	49	54	42
ACL634C	148,0	126,6	147,2	36400	29400	52	46	4x630	715,1	65	60	48			
ACQ632A	46,8	40,6	46,7	14300	11500	42	34	P=330W I _n =0.80A n=650min ⁻¹	P=190W I _n =0.38A n=480min ⁻¹	P=400W I _n =1.8A n=650min ⁻¹	2x630	177	17	35	28
ACQ632B	55,1	45,9	54,9	13600	10800	42	34				2x630	265,5	24,7	42	28
ACQ632C	57,6	46,9	57,4	13000	10100	42	34				2x630	353,9	33	42	28
ACQ633A	69,5	60,7	69,3	21500	17200	44	36				3x630	267,3	25,5	42	28
ACQ633B	82,2	68,8	81,9	20500	16200	44	36				3x630	400,9	37	54	35
ACQ633C	84,9	69,7	84,6	19600	15200	44	36				3x630	534,5	49,5	54	35
ACQ634A	94,3	81,7	94,0	28600	23000	45	37				4x630	357,6	34	54	42
ACQ634B	104,6	89,2	104,3	27400	21600	45	37				4x630	536,3	49	54	42
ACQ634C	112,9	92,9	112,6	26200	20300	45	37	4x630	715,1	65	60	48			
ACR632A	35,6	30,0	-	9500	7500	32	26	P=125W I _n =0.33A n=430min ⁻¹	P=85W I _n =0.14A n=330min ⁻¹	-	2x630	177	17	35	28
ACR632B	39,8	32,6	-	9000	7000	32	26				2x630	265,5	24,7	42	28
ACR632C	40,7	32,3	-	8500	6600	32	26				2x630	353,9	33	42	28
ACR633A	53,3	45,1	-	14200	11200	34	28				3x630	267,3	25,5	42	28
ACR633B	59,7	48,7	-	13500	10500	34	28				3x630	400,9	37	54	35
ACR633C	60,4	48,2	-	12800	9900	34	28				3x630	534,5	49,5	54	35
ACR634A	71,6	60,3	-	18900	15000	35	29				4x630	357,6	34	54	42
ACR634B	78,1	64,0	-	18000	14000	35	29				4x630	536,3	49	54	42
ACR634C	80,6	64,3	-	17100	13200	35	29	4x630	715,1	65	60	48			

Nominal capacities according to standard ENV327(R404A Tair=25°C, Tcond=40°C, ΔTsubcool<3K, ΔTsuperheat=25K).

* See the "General Contents" for more details.

Model	Capacity [kW]		Airflow [m³/h]		Lp [dB(A)]*		Motor (3/400V-50Hz)		Fans	Surface	Tube volume	Conn.	
	Δ	Y	Δ	Y	Δ	Y	Δ	Y	N° x D [mm]	m²	dm³	mm	
	Ø 800												Inlet
ACS802A	96,7	83,8	42400	32500	54	47	P=2000W I _n =4,0A n=880min-1	P=1250W I _n =2,3A n=660min-1	2x800	238,7	21	48	42
ACS802B	123,4	103,7	39500	29900	54	47			2x800	358	31,3	54	42
ACS802C	137,0	111,3	37000	27600	54	47			2x800	477,4	42	54	42
ACS803A	149,4	130,3	63600	48900	56	49			3x800	360,3	31,6	54	42
ACS803B	186,1	156,3	59400	44900	56	49			3x800	540,5	47,4	60	48
ACS803C	206,5	167,8	55600	41600	56	49			3x800	720,7	63	60	48
ACS804A	194,9	169,0	84900	65300	57	50			4x800	482	42	54	42
ACS804B	241,5	202,1	79200	59900	57	50			4x800	723	63,4	60	48
ACS804C	272,1	223,4	74300	55500	57	50			4x800	964	84,5	60	48
ACS805A	249,5	216,7	106200	81600	58	51			5x800	603,7	53	54	42
ACS805B	309,4	259,1	99100	75000	58	51			5x800	905,5	79	60	48
ACS805C	342,5	277,9	92900	69500	58	51			5x800	1207,4	106	76	54
ACL802A	82,0	72,3	32600	26200	47	42	P=1050W I _n =2,4A n=680min-1	P=770W I _n =1,5A n=530min-1	2x800	238,7	21	48	42
ACL802B	101,2	86,3	30400	24000	47	42			2x800	358	31,3	54	42
ACL802C	113,3	94,5	28500	22300	47	42			2x800	477,4	42	54	42
ACL803A	130,5	115,4	49000	39400	49	44			3x800	360,3	31,6	54	42
ACL803B	158,2	135,0	45700	36200	49	44			3x800	540,5	47,4	60	48
ACL803C	171,6	142,3	42900	33500	49	44			3x800	720,7	63	60	48
ACL804A	169,2	149,1	65400	52600	50	45			4x800	482	42	54	42
ACL804B	204,6	174,4	61100	48300	50	45			4x800	723	63,4	60	48
ACL804C	228,3	190,4	57200	44700	50	45			4x800	964	84,5	60	48
ACL805A	216,9	191,3	81800	65800	51	47			5x800	603,7	53	54	42
ACL805B	262,2	223,5	76400	60400	51	47			5x800	905,5	79	60	48
ACL805C	284,2	235,5	71600	55900	51	47			5x800	1207,4	106	76	54
ACQ802A	65,0	54,3	20100	15300	38	32	P=370 I _n =1,2A n=440min-1	P=200W I _n =0,5A n=340min-1	2x800	238,7	21	48	42
ACQ802B	74,2	59,8	18500	13900	38	32			2x800	358	31,3	54	42
ACQ802C	77,1	60,7	17200	12900	38	32			2x800	477,4	42	54	42
ACQ803A	98,0	81,8	30200	23000	40	34			3x800	360,3	31,6	54	42
ACQ803B	111,0	89,9	27900	21000	40	34			3x800	540,5	47,4	60	48
ACQ803C	115,7	90,8	25900	19400	40	34			3x800	720,7	63	60	48
ACQ804A	126,3	106,0	40300	30700	41	35			4x800	482	42	54	42
ACQ804B	149,6	120,6	37200	28000	41	35			4x800	723	63,4	60	48
ACQ804C	155,2	122,1	34600	25800	41	35			4x800	964	84,5	60	48
ACQ805A	162,0	135,1	50400	38400	42	36			5x800	603,7	53	54	42
ACQ805B	184,8	151,0	46500	35000	42	36			5x800	905,5	79	60	48
ACQ805C	192,0	151,2	43200	32300	42	36			5x800	1207,4	106	76	54
ACR802A	60,3	43,5	17900	11200	35	24	P=250W I _n =0,62A n=380min-1	P=110W I _n =0,27A n=240min-1	2x800	238,7	21	48	42
ACR802B	67,3	46,3	16300	10000	35	24			2x800	358	31,3	54	42
ACR802C	68,8	44,8	15000	9100	35	24			2x800	477,4	42	54	42
ACR803A	90,9	65,6	26900	16900	37	26			3x800	360,3	31,6	54	42
ACR803B	101,2	68,7	24500	15100	37	26			3x800	540,5	47,4	60	48
ACR803C	103,3	67,2	22600	13600	37	26			3x800	720,7	63	60	48
ACR804A	117,1	87,6	35900	22600	38	27			4x800	482	42	54	42
ACR804B	136,0	92,4	32700	20100	38	27			4x800	723	63,4	60	48
ACR804C	138,5	90,1	30100	18200	38	27			4x800	964	84,5	60	48
ACR805A	150,2	109,2	44900	28200	39	28			5x800	603,7	53	54	42
ACR805B	168,5	116,9	41000	25200	39	28			5x800	905,5	79	60	48
ACR805C	171,9	111,9	37700	22800	39	28			5x800	1207,4	106	76	54

Nominal capacities according to standard ENV327(R404A Tair=25°C, Tcond=40°C, ΔTsubcool<3K, ΔTsuperheat=25K).

* See the "General Contents" for more details.

Model	Capacity [kW]		Airflow [m ³ /h]		Lp [dB(A)]*		Motor (3/400V-50Hz)		Fans	Surface	Tube volume	Conn.	
	Δ	Y	Δ	Y	Δ	Y	Δ	Y	N° x D [mm]	m ²	dm ³	mm	
													Inlet
Ø 910													
ACS902A	113,0	98,3	44500	34700	57	51	P=1650W I _n =3.5A n=860min ⁻¹	P=1000W, I _n =1.8A n=660min ⁻¹	2x910	299,5	27	48	42
ACS902B	138,9	118,1	42100	32500	57	51			2x910	449,3	41	54	42
ACS902C	155,0	127,9	40100	30700	57	51			2x910	604,6	53	54	42
ACS903A	164,7	143,1	66800	52200	59	53			3x910	451,6	40,9	60	48
ACS903B	209,3	177,8	63300	48900	59	53			3x910	677,5	61,5	60	48
ACS903C	232,4	191,6	60000	45900	59	53			3x910	903,3	80	60	48
ACS904A	227,4	197,7	89100	69600	60	54			4x910	603,7	53	60	48
ACS904B	279,9	235,6	84400	65200	60	54			4x910	905,5	79	76	54
ACS904C	308,4	252,7	80000	61300	60	54	4x910	1207,4	106	76	54		
ACL902A	95,7	76,5	33200	23200	50	42	P=900W I _n =2.2A n=640min ⁻¹	P=470W I _n =1.05A n=440min ⁻¹	2x910	299,5	27	48	42
ACL902B	115,3	88,9	31400	21700	50	42			2x910	449,3	41	54	42
ACL902C	125,3	93,2	29800	20600	50	42			2x910	604,6	53	54	42
ACL903A	139,3	111,4	49800	34900	52	44			3x910	451,6	40,9	60	48
ACL903B	173,6	133,8	47100	32700	52	44			3x910	677,5	61,5	60	48
ACL903C	187,8	139,6	44700	30800	52	44			3x910	903,3	80	60	48
ACL904A	192,4	153,9	66500	46600	53	45			4x910	603,7	53	60	48
ACL904B	229,8	175,9	62900	43600	53	45			4x910	905,5	79	76	54
ACL904C	247,6	187,7	59600	41100	53	45	4x910	1207,4	106	76	54		
ACQ902A	73,7	62,2	21500	16700	40	34	P=330W I _n =0.83A n=440min ⁻¹	P=185W I _n =0.38A n=330min ⁻¹	2x910	299,5	27	48	42
ACQ902B	84,3	68,5	20300	15600	40	34			2x910	449,3	41	54	42
ACQ902C	87,0	69,6	19200	14700	40	34			2x910	604,6	53	54	42
ACQ903A	111,0	93,7	32300	25200	42	36			3x910	451,6	40,9	60	48
ACQ903B	126,8	103,1	30400	23400	42	36			3x910	677,5	61,5	60	48
ACQ903C	128,9	103,4	28700	22000	42	36			3x910	903,3	80	60	48
ACQ904A	146,2	122,8	43100	33600	43	37			4x910	603,7	53	60	48
ACQ904B	166,4	136,5	40600	31200	43	37			4x910	905,5	79	76	54
ACQ904C	174,2	139,1	38300	29300	43	37	4x910	1207,4	106	76	54		
ACR902A	70,2	50,2	20000	12500	37	25	P=270W I _n =0.70A n=390min ⁻¹	P=140W I _n =0.32A n=250min ⁻¹	2x910	299,5	27	48	42
ACR902B	79,2	53,9	18700	11500	37	25			2x910	449,3	41	54	42
ACR902C	81,2	53,2	17600	10800	37	25			2x910	604,6	53	54	42
ACR903A	105,6	75,6	30000	18800	39	27			3x910	451,6	40,9	60	48
ACR903B	119,1	81,0	28100	17300	39	27			3x910	677,5	61,5	60	48
ACR903C	120,5	79,3	26400	16200	39	27			3x910	903,3	80	60	48
ACR904A	138,9	100,7	40000	25000	40	28			4x910	603,7	53	60	48
ACR904B	156,9	106,7	37400	23100	40	28			4x910	905,5	79	76	54
ACR904C	162,5	106,5	35200	21600	40	28	4x910	1207,4	106	76	54		

Nominal capacities according to standard ENV327(R404A T_{air}=25°C, T_{cond}=40°C, ΔT_{subcool}<3K, ΔT_{superheat}=25K).

* See the "General Contents" for more details.

AC - Single Fan Row

Drawings

Model	Dimensions (mm)				Weight [Kg]	N° of feet
	A	B	C	D		
Ø 400						
AC_401A	780	660	630	see drawing	20	4
AC_401B	780	660	630	see drawing	25	4
AC_402A	1380	1260	1230	see drawing	40	4
AC_402B	1380	1260	1230	see drawing	46	4
AC_403A	1980	1860	1830	see drawing	62	4
AC_403B	1980	1860	1830	see drawing	68	4
Ø 500						
AC_501A	1142	940	-	see drawing	56	4
AC_501B	1142	940	-	see drawing	61	4
AC_501C	1142	940	-	see drawing	67	4
AC_502A	2042	1840	-	see drawing	97	4
AC_502B	2042	1840	-	see drawing	106	4
AC_502C	2042	1840	-	see drawing	115	4
AC_503A	2942	2740	-	see drawing	134	4
AC_503B	2942	2740	-	see drawing	151	4
AC_503C	2942	2740	-	see drawing	165	4
AC_504B	3842	3640	1800	see drawing	204	6
AC_504C	3842	3640	1800	see drawing	223	6
Ø 630						
AC_632A	3177	2500	-	see drawing	233	4
AC_632B	3177	2500	-	see drawing	257	4
AC_632C	3177	2500	-	see drawing	281	4
AC_633A	4427	3750	-	see drawing	328	4
AC_633B	4427	3750	-	see drawing	367	4
AC_633C	4427	3750	-	see drawing	403	4
AC_634A	5677	5000	2500	see drawing	430	6
AC_634B	5677	5000	2500	see drawing	477	6
AC_634C	5677	5000	2500	see drawing	525	6
Ø 800						
AC_802A	3097	2620	-	238	303	4
AC_802B	3097	2620	-	238	336	4
AC_802C	3097	2620	-	238	368	4
AC_803A	4407	3930	-	238	427	4
AC_803B	4407	3930	-	238	475	4
AC_803C	4407	3930	-	238	523	4
AC_804A	5717	5240	2620	238	553	6
AC_804B	5717	5240	2620	238	617	6
AC_804C	5717	5240	2620	238	681	6
AC_805A	7027	6550	2620	238	679	8
AC_805B	7027	6550	2620	238	760	8
AC_805C	7027	6550	2620	238	843	8
Ø 910						
AC_902A	4081	3276	-	402	374	4
AC_902B	4081	3276	-	402	415	4
AC_902C	4081	3276	-	402	455	4
AC_903A	5719	4914	-	402	529	4
AC_903B	5719	4914	-	402	591	4
AC_903C	5719	4914	-	402	651	4
AC_904A	7357	6552	3276	402	686	6
AC_904B	7357	6552	3276	402	769	6
AC_904C	7357	6552	3276	402	849	6

We reserve the right to change our technical data without prior notice.

Ø 400

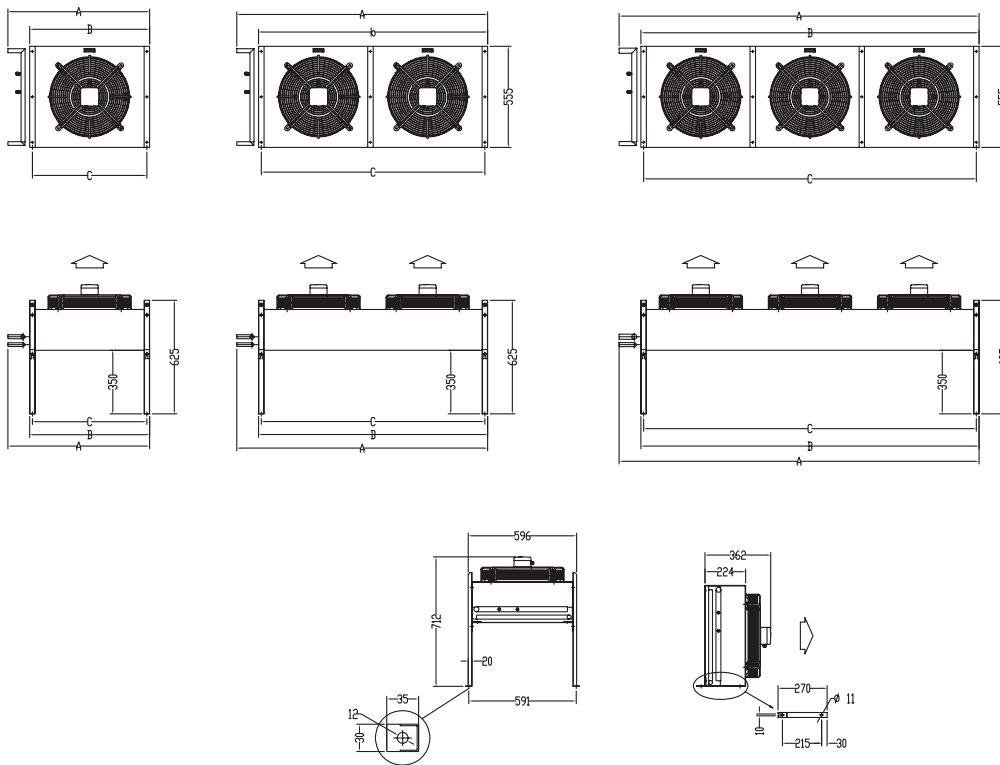

Ø 500

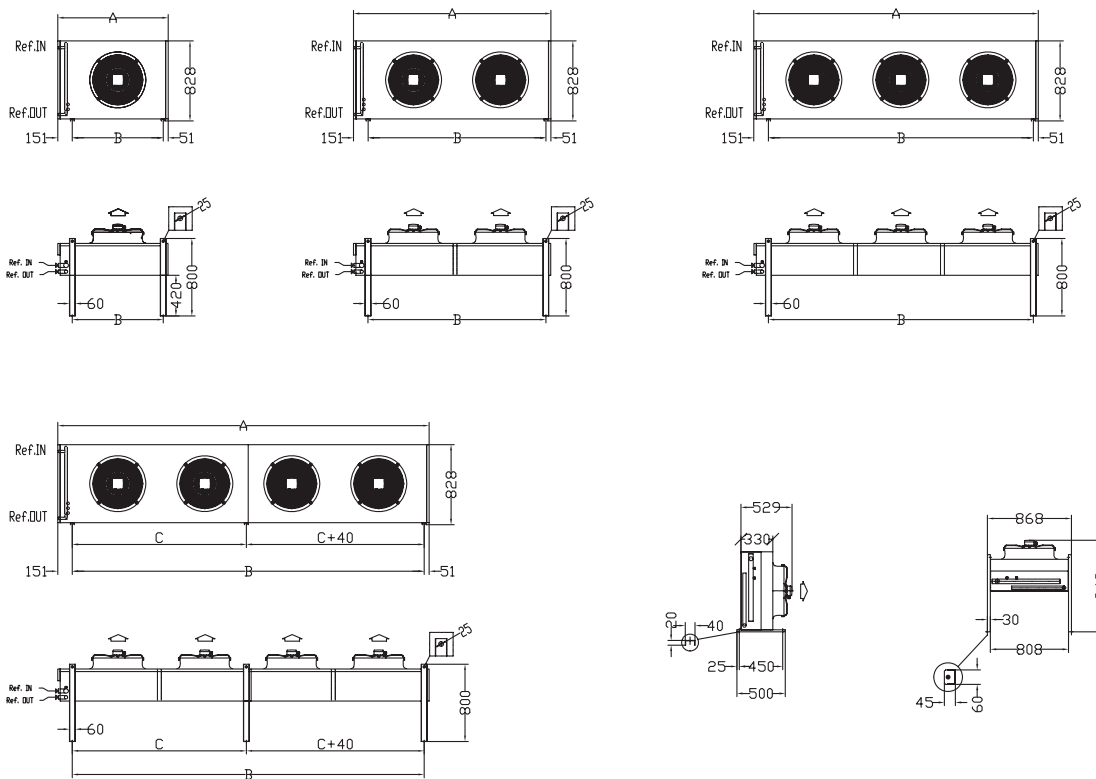

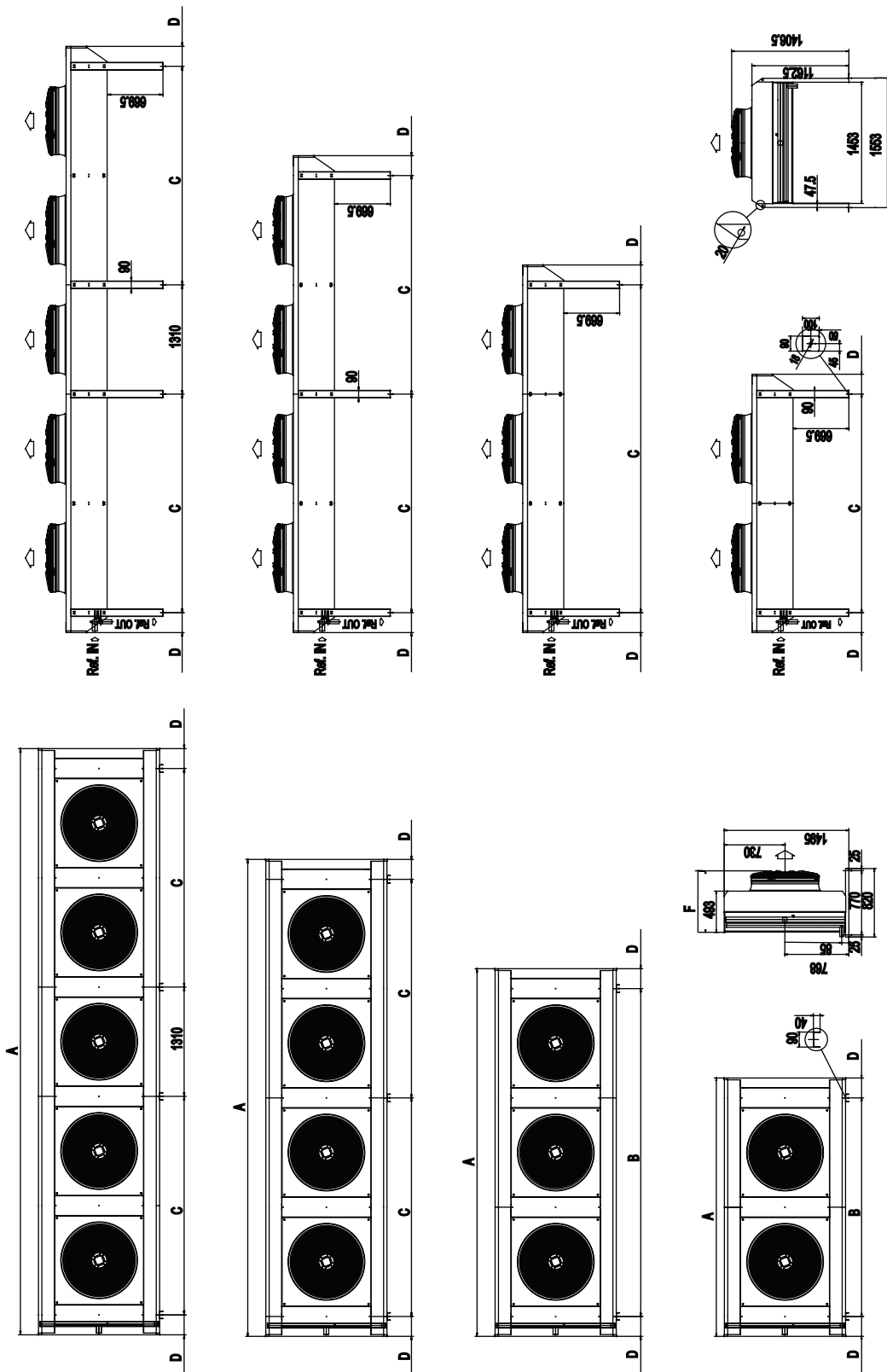

AC - Single Fan Row

Options

Motor fans



(a) Fan motor 400 V/3ph - 60Hz, IP54: S/L for Ø 400, also Q for Ø 500; S/L/Q/R for Ø 630/800/910
 (b) Fan motor 460 V/3ph - 60Hz, IP54: S/L for Ø 400, also Q for Ø 500; S/L/Q/R for Ø 630/800/910
 (c) Fan motor 230V/1ph - 50/60Hz, IP54: S/L for Ø 400, and also Q for Ø 500; L/Q for Ø 630

Model:
 Ø 400^(a,b,c)
 Ø 500^(a,b,c)
 Ø 630^(a,b,c)
 Ø 800 ^(a,b)
 Ø 910^(a,b)

Local safety switch wired

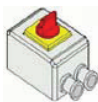

See Electrical Data Page.

Model:
 All Models

Terminal Box

See Electrical Data Page.

Model:
 All Models

Switchboard and cabling

Function

Switchboard for supply and control of fan motors.
 A switchboard can supply up to 8 individual motors or 8 paired motors (i.e. max. of 16 motors).
 Switchboard and cabling are supplied as standard for vertical installation of the unit.
 If you have different needs, please specify these when placing your order.

Operating conditions

Type of installation: External wall mounted
 Protection class: IP55 door closed
 Climate: Normal
 Operating temperature: -10 ÷ +35°C (base) -25 ÷ +50°C (with options)
 Ambient relative humidity: <95%
 Altitude: <1000metres above sea level

Electrical data

Insulating nominal voltage: 690V
 Operating voltage: 3Ph. 400Vac
 Frequency: 50Hz
 Auxiliaries voltage: 24-230V
 Nominal current: Max 80A

Mechanical data

Material: Pre-painted galvanized steel
 Fixing plate: Sheet of steel (min. thickness 15/10 Sendzimir galvanized)
 Gasket: Polyurethane
 Door: opening more than 180°.
 Colour: RAL 7035
 Cable gland: metric ISO

Model:
 All Models

Switchboard Options		
	<p>R anti-condensate resistor 230Vac (operating temperature $-25 \div +35^{\circ}\text{C}$)</p> <p>C cooling fan 230Vac (operating temperature $-10 \div +50^{\circ}\text{C}$)</p> <p>F cooling fan + anti-condensate resistor</p>	<p>Model: All Models</p>
Fan Speed Control		
	<p>Speed controller in plastic covering box, IP55, complies with EMC regulations. The FSC checks and regulates the speed rotation of the electric motor fans, keeping the pressure of the condensers within the range of preset values. Continuous control of fan speed is obtained through the variation of the electrical supply by phase-cut. Wiring of the fan speed control is supplied as standard for vertical installation. If the customer requires horizontal installation, he has to change this himself. The cost for this adaptation is not included.</p> <p>Control inputs: 0÷10Vdc, 4÷20mA from pressure probe NTC/external potentiometer 10kOhm/ digital keyboard.</p> <p>Ramp: 0.1÷ 25.5 seconds.</p> <p>Digital inputs: Start / stop, emergency (fans thermal probe), max. power or secondary speed and heat / cool, or 2 cool cycles.</p> <p>Analogue output: Signal 0 ÷ 10Vdc for command regulator slave.</p> <p>Digital output: Relay contact NO/NC max 1A-230Vac/3A-30Vdc.</p> <p>For 230V/1ph 50Hz and 400/3ph 50Hz fan motors.</p>	<p>Model: Ø 400 Ø 500</p>
Switchboard with Fan Speed control		
	<p>Switchboard and cabling including an electronic fan motor speed controller. This equipment continually checks and regulates the rotation speed of the fan's motor, keeping the condensing pressure within the range or pre-defined values. Constant control of the fan speed is achieved by variation of the electrical supply by phase-cut, as determined by the probe signal. The fan speed controller comes pre-connected to the switchboard. If you have different needs, please specify these when placing your order.</p>	<p>Model: Ø 630 Ø 800 Ø 910</p>
Switchboard with Fan Step control		
	<p>Switchboard and cabling including an automatic on/off switch that checks and regulates the rotation speed of the fan's motor, keeping the condensing pressure within the range or pre-defined values. Control of the fan speed is achieved by variation of the electrical supply by the ON/OFF device, as determined by the probe signal. The fan step controller comes pre-connected to the switchboard. If you have different needs, please specify these when placing your order.</p>	<p>Model: All Models</p>
Coil Treatment / Material		
	<p>Thermoguard for industrial or sea coast application.</p> <p>Aluminium fins pre-coated.</p> <p>Copper fins.</p> <p>Application Use: More information on corrosion prevention can be found in the Miscellaneous section.</p>	<p>Model: All Models</p>
Multi-circuits		
	<p>All models are suitable for multi-circuits, enabling more than one refrigeration system to operate with a single condenser.</p>	<p>Model: All Models</p>
Sub-cooling circuit		
	<p>Sub-cooling is achieved by the use of an integrated sub-cooling section which harnesses approximately 10% of the coil surface. This provides 6-7°C max. of sub-cooling at the standard rate condition of 15K. The overall effect on the condensing capacity is a reduction of 10%. However, the overall heat rejection inclusive of sub-cooling capacity will only be reduced by 5%.</p>	<p>Model: All Models</p>
Non-standard fin spacing		
	<p>The standard fin spacing is 2.1mm.</p> <p>Alternative: 2.5mm and 3.2mm.</p>	<p>Model: All Models</p>

Feet

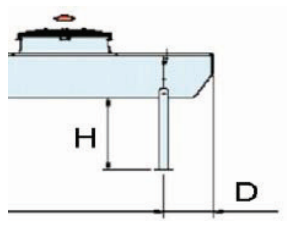

Model Ø	H	CODE
401	350 mm	10999017
402-3 / 501-2-3	420 mm	10999015
504	420 mm	10999016
632-3 / 802-3 / 902-3	700 mm	10999005
634 / 804 / 904	700 mm	10999006
805	700 mm	10999007

Model:
All Models

Vibration Dampers

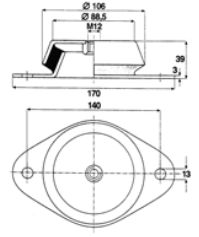

Type	H mm	A mm	B mm	C mm	D mm	Weight Kg
Single Row	39	140	170	M12	13	2

Model:
All Models

Nuts and bolts are not included with these dampers.

AC - Single Fan Row

Electrical Data

Safety Switch

Function

Local safety switch and cabling for each electric fan motor.

General data

Power Supply:

- 400VAC, 50/60Hz
- Max fuse 16A

Number of poles: 3P

Cabinet Material: Plastic Case

Cabinet Colour: Grey (Yellow-Red Knob)

Protection Class: Min IP65

Ambient Temp.: min. -25°C, max. +50°C

Weight: Approx. 0.4Kg

Dimensions

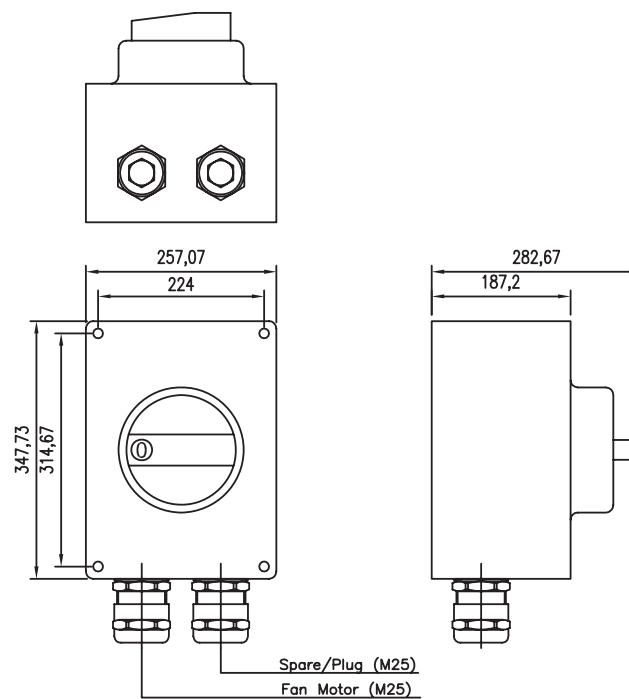

AC - Single Fan Row

Code description

Code No.

	1	2	3	4
AC	S	63	2	A

1) Type of noise level (number of dB(A) to reduce compared with "base" version)

	Standard noise level	Low noise level	Quiet noise level	Residential noise level
	S*	L*	Q*	R*
Fan Ø 400 mm	std	-10	-	-
Fan Ø 500 mm	std	-9	-19	-
Fan Ø 630 mm	std	-13	-20	-30
Fan Ø 800/910 mm	std	-10	-20	-23

2) Fan diameter Ø

40	400 mm
50	500 mm
63	630 mm
80	800 mm
90	910 mm

3) Number of Fans (* available in this version)

	Ø 400 mm	Ø 500 mm	Ø 630 mm	800 mm	Ø 910 mm
1	*	*	-	-	-
2	*	*	*	*	*
3	*	*	*	*	*
4	-	*	*	*	*
5	-	-	-	*	-

4) Number of coil rows

A	2
B	3
C	4

General Alfa Select Air Legend

Description 1		Description 2	
D	D fan cabling (three phase)	BSFT	Basic Switch Board + Speed Control Temp. + Signal
Y	Y fan cabling (three phase)	BI	Basic Switch Board + Frequency Converter (Inverter)
D/Y	D/Y fan cabling (three phase), single speed fan motor	BSI	Basic Switch Board + Frequency Converter (Inverter) + Signal
S	Single phase	C	Switch Board + Cooling fan
P	Packaged on a pallet	R	Switch Board + Resistor
CR	Packaged in a crate	F	Switch Board + Cooling fan + Resistor
BO	Packaged in a box	PT	Ammonia pump top
Feet	Feet-mounted	PB	Ammonia pump bottom
SW	Safety Switch	AL	Aluminium casing
CB	Terminal Box	SS	Stainless Steel casing
B	Basic Switch Board	AP	Pre-painted Aluminium casing
BS	Basic Switch Board + Signal	PL	Plastic casing
BP	Basic Switch Board + Step Control Pressure	E	Electrical defrost
PT	Basic Switch Board + Step Control Temperature	LE	Low Electrical defrost
BSP	Basic Switch Board + Step Control Pressure + Signal	A	Air Defrost
BST	Basic Switch Board + Step Control Temp. + Signal	HG	Hot Gas Defrost
BFP	Basic Switch Board + Speed Control Pressure	HG+E	Hot Gas Defrost + Electrical Defrost on drip tray
BFT	Basic Switch Board + Speed Control Temperature	W	Water Defrost
BSFP	Basic Switch Board + Speed Control Pres. + Signal	W+E	Water Defrost + Electrical Defrost on drip tray
AL	Aluminium fin	CU	Copper fin
PR	Pre-coated fin	SS	Stainless steel tube
TH	Thermoguard treatment	CF	Cataphoresis treatment
SC	Sub-cooling circuit	KW	Spray water kit
FH	Fan ring heater	FL	Flanges
IS	Insulated Drip Tray	RH	Reheating coil
ER	120° elbow reducer	SR	Air socket adapter ring
HN	Hinged fan cowling	CW	Air throw fan cowling

Note: Valid for the entire product range.

Alfa V- ACV

General Contents

General Features

All products are designed to satisfy both commercial and industrial refrigeration, air conditioning, and retail refrigeration. All axial condensers are available in the following versions:

- Vertical airflow direction
- Most common refrigerant HFC, such as R404A, R507C, R407C, R134a

Relative footprint, low consumption and low noise levels are the keys to this series' success.

Certifications and reliability

All Air Cooled condensers are guaranteed by Eurovent "Certify All". Alfa Laval quality systems fully comply with ISO 9001, and all of our products are manufactured in strict accordance with CE regulations.

Capacity

The standard conditions are in accordance with EN 327 (R404A, T. air = 25°C, T.cond.= 40°C, ΔT sub-cool < 3K, ΔT superheat = 25K).

How to work out the condenser's capacity:

$$Q_c = Q_f \times F_r \times F_1 \times F_2 \times F_3 \times F_4 \times F_5 \times F_6$$

Q_c = Condenser capacity

Q_f = Evaporator capacity

F_r = Condensing Temp (T_c) and evaporating Temp factor. (T_e).

F₁ = Compressor factor

F₂ = Refrigerant factor

F₃ = ΔT factor (15/ΔT)

F₄ = Altitude factor

F₅ = Fin material

F₆ = Ambient temperature factor

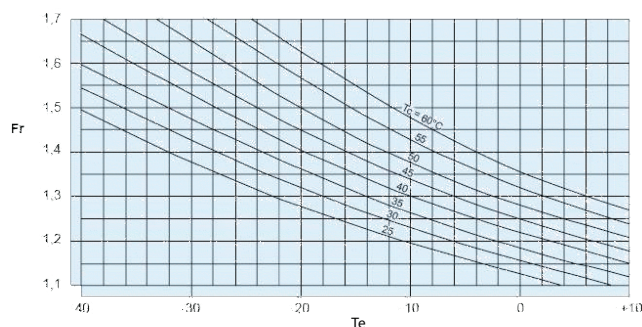

Compressor	Open	Semi-hermetic	Hermetic
F1	1	1,08	1,14

Refrigerant	R507A	R404A	R134a	R22	R407C
F2	1	1	0,93	0,96	0,87

Altitude (m)	0	500	1000	1500	2000
F4	1	1,028	1,06	1,09	1,12

Fin material	Al	Al Prv	Cu
F5	1	1,03	0,97

Ambient Temp.	15	20	25	30	35
F6	0,975	0,988	1,00	1,013	1,026

Tube Protection

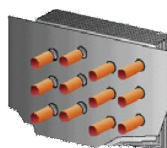

Due to the thermal expansion of the copper pipes, all metal sheets are equipped with an aluminium plate with collars. This plate supports the tube and therefore the pipes must not come into contact with the metal sheets. With this solution, the vibrations and thermal expansion are absorbed by the aluminium sheet. Leaks caused by friction cannot occur. The rigidity of the coil is sustained effectively.

Energy Efficiency Class

Energy efficiency class of air cooled condensers		
Class	Energy consumption	R
A	Extremely low	R>110
B	Very low	70≤R<110
C	Low	45≤R<70
D	Medium	30≤R<45
E	High	R<30

R = Condenser capacity (ΔT15K) / motor power consumption.

Test and cleaning

The coils are cleaned and dehydrated in order to remove any traces of oil.

Each heat exchanger undergoes a pressure and leak test with dry air at 34 bar, before being supplied with a nitrogen pre-charge.



Sound Data

The sound pressure level is based on the calculation (according to EN 13487) of the sound pressure level on the surface of a cuboid area which is at a 10 metre distance and is parallel to the reference envelope of the sound source. (Standard sound pressure level; annex C EN 13487)

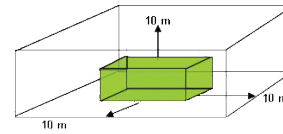

Sound pressure correction for distances other than 10 metres.

Distance (m)	2	3	4	5	7	10	15	20	30	40	50	60	80
Correction dB(A)	11	8,5	7	5	2,5	0	-3	-5,5	-9	-11	-12	-14	-16

Sound pressure level for several fans at nominal speed rating.

N° units	2	3	4	5	6	7	8	9	10
dB(A)	3	5	6	7	8	8,5	9	9,5	10

To calculate the sound pressure level, take the sound power of the individual fans according to their position, and calculate the sound propagation taking into consideration the local and ambient conditions. Speed change, start-up and control noises are not taken into account.

Fan Model	Speed rpm		Total Lw dB(A)		LW octave band spectrum dB(A)															
	Δ	Y	Δ	Y	63Hz		125Hz		250Hz		500Hz		1 000Hz		2 000Hz		4 000Hz		8 000Hz	
800 S	880	660	83	76	-	-	69	56	67	62	74	69	78	74	79	72	72	64	62	54
800 L	680	530	76	71	-	-	57	49	62	57	69	63	74	68	72	63	65	55	55	45
800 Q	440	340	66	60	-	-	47	42	57	48	59	54	63	56	58	51	50	43	39	34
800 R	380	240	63	52	-	-	47	42	54	44	57	47	59	48	55	42	47	34	35	26
910 T	890	700	90	83	-	-	72	70	79	73	82	76	84	79	82	76	79	73	73	66
910 S	860	660	85	79	-	-	72	70	79	73	82	76	84	79	82	76	79	73	73	66
910 L	640	440	78	70	-	-	68	62	73	68	76	70	77	70	76	70	73	67	66	60
910 Q	440	330	68	62	-	-	57	49	61	58	64	57	67	60	61	53	52	45	43	35
910 R	390	250	65	53	-	-	56	46	59	45	59	46	61	49	56	44	48	35	38	22
1000 L	680	550	86	81	-	-	58	53	68	60	70	63	73	68	75	67	71	62	62	53
1000 Q	425	325	72	65	-	-	50	45	58	50	62	54	65	58	60	50	54	42	44	30
1000 R	390	260	70	61	-	-	50	44	56	45	60	49	64	52	55	44	48	36	37	25

Guarantee

All our products are protected under warranty for 18 months from the shipping date. If a defect should occur within the warranty period, please return the equipment or part to our factory free of charge where we will repair or replace the goods, depending on what is required. Unfortunately, We cannot take responsibility for damage caused by the misuse or incorrect installation of our products. The brochure is subject to technical changes without prior notice

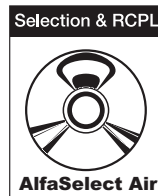

We recommend that you use the Alfa Select Air software for a precise thermal and mechanical design.



Alfa V- ACV

Product description

Application

The Alfa Laval Condenser can be used in refrigeration and air conditioning equipment.

Standard design

Coil

Optimized "V-type" design provides large capacity within a compact size. An innovative heat exchanger that gives excellent heat transfer with minimal refrigerant costs, thanks to the new fin corrugation developed by Alfa Laval, combined with advanced cross-fin tubes. In the standard execution, heat exchanger manufactured from copper tubes and aluminum fins with spacing 2.1 mm. Double connection provides opportunity for two completely independent heat exchangers. Each heat exchanger undergoes a pressure and leak test with dry air at 34bar, before being supplied with a pre-charge of nitrogen.

Casing

Casework is made from galvanized steel sheets painted with an epoxy finish, RAL 9002. New frame design provides greater rigidity for heavy applications. The new system protects the heat exchanger tubes completely during transportation and against vibration and thermal expansion while in operation. Support made of galvanized steel.

Benefits

- Footprint
 - Optimises footprint with higher capacity 800, 910 and 1000mm fan.
 - More performance available
 - Low power consumption fan motor
 - More noise level options
 - Flexible design
- All parts are painted in accordance with RAL 9002
 - No cut edges
 - Higher corrosion resistance, double surface treatment
- Coil design
 - Increased heat transfer thanks to innovative fin corrugation
- Casing
 - Strong casing with new design
- High energy efficiency
 - Best performance with low energy consumption

Options

- Non-standard fin spacing
 - For dusty environments
- Multi-circuits
 - total capacity split in multiple compressor lines
- Coil treatment



- Corrosion resistance
- Suitable for aggressive environments
- Spray water device
 - Smaller units can be selected.
 - Maintain performance during outdoor temperature peaks.
- Vibration dampers
 - Designed to reduce vibrations
- Special fans
 - EC fans
 - Best alternative for frequency converter control 480/3ph-60Hz, IP54
 - High adaptability on every market, IP55
 - High protection fan for use in tropical or desert areas
- Electrical parts
 - Switch on/off
 - Local safety switch wired to isolate the fan. An EMC switch is also available
 - Terminal box
 - All fans are wired for easy connection to the electrical supply
 - Switchboard
 - Build reliability

- Corrosion / Shock / Condensation / UV-resistant
- Wide range of solutions
- IP66 for casing, IP56 for switchboard
- 100% recyclable
- Cabling
 - Ready for installation
- Design for frequency converter
 - Units can run under frequency control (when air temperature falls below the designated level, it triggers energy saving, noise reduction and enables longer fan motor life)
- Fan step control
 - Energy saving
 - Cheapest method of controlling performance
- Fan speed control
 - Energy saving
 - Noise reduction when air temperature is below designated level.
 - Variable and efficient control of velocity according to heat reject.
 - Better performance control

Fans

Three different fan diameters available: 800, 910 and 1000mm with a 400V-50Hz three-phase motor. The motors come with external rotors, made in accordance with VDE 0530/12.84, IP54. The Axial Condensers 800 and 910 are available in 4 fan motor noise levels: (S) standard, (L) low, (Q) quiet, (R) residential, only for 910mm, also (T) high performance fan. The Axial Condensers 1000 are available in three fan motor noise levels: (L) low, (Q) quiet, (R) residential.

Each fan chamber is separated by internal baffle plates which enable optimal capacity control by separate running of the fans. For air temperatures lower than +20°C, the full load current (FLC) can be calculated using the correction factor table. The overload protectors should have a 20% margin to accommodate fan motor supplier variations.

T [°C]	20	10	0	-10	-15	-20	-25	-30
Fc	1	1,04	1,08	1,12	1,14	1,16	1,18	1,2

Model	Capacity		Airflow		Lp [dB(A)]*		Motor (3/400V-50Hz)		E.E.C.**		Fans	Surface	Tube volume	Conn.			
	[kW]		[m3/h]		(10m)						N° x D [mm]	m²	dm³	mm			
	Δ	Y	Δ	Y	Δ	Y	Δ	Y	Δ	Y				Inlet	Outlet		
Ø 800																	
ACVS802B	297	252	88731	69069	56	51	P=2000W I=4,0A n=880 min-1	P=1250W I=2,3A n=660 min-1	D	C	4 x 900	954,7	83	2x54	2x48		
ACVS802C	333	275	85874	66226	56	51			C	C	4 x 900	1273	110	2x54	2x48		
ACVS803B	448	380	133238	103748	58	53			D	C	6 x 900	1441,4	125	2x76	2x60		
ACVS803C	501	414	128995	99519	58	53			C	C	6 x 900	1921,9	166	2x76	2x60		
ACVS804B	589	498	177744	138425	59	54			D	C	8 x 900	1928	167	2x76	2x60		
ACVS804C	659	543	172114	132810	59	54			C	C	8 x 900	2570,7	222	2x76	2x60		
ACVS805B	750	635	222249	173101	60	55			D	C	10 x 900	2414,7	209	2x76	2x60		
ACVS805C	838	691	215232	166101	60	55			C	C	10 x 900	3219,6	278	2x90	2x76		
ACVS806B	900	763	266754	207778	61	56			D	C	12 x 900	2901,4	251	2x90	2x76		
ACVS806C	1006	830	258350	199391	61	56			C	C	12 x 900	3868,5	334	4x76	2x90		
ACVS807B	1048	891	311259	242454	61	56			D	C	14 x 900	3388	292	4x76	2x90		
ACVS807C	1175	972	301468	232681	61	56			C	C	14 x 900	4517,4	390	4x76	2x90		
ACVS808B	1182	1012	355764	277130	62	57			D	C	16 x 900	3874,7	334	4x76	2x90		
ACVS808C	1333	1108	344586	265972	62	57			C	C	16 x 900	5166,2	446	4x76	2x90		
ACVL802B	245	217	66270	55905	49	45			P=1050W I=2,4A n=680 min-1	P=770W I=1,5A n=530 min-1	C	B	4 x 900	954,7	83	2x54	2x48
ACVL802C	269	233	64253	53548	49	45					B	B	4 x 900	1273	110	2x54	2x48
ACVL803B	369	327	99504	83977	51	47	C	B			6 x 900	1441,4	125	2x76	2x60		
ACVL803C	404	350	96510	80469	51	47	B	B			6 x 900	1921,9	166	2x76	2x60		
ACVL804B	484	428	132737	112048	52	48	C	B			8 x 900	1928	167	2x76	2x60		
ACVL804C	532	468	128765	107390	52	48	B	B			8 x 900	2570,7	222	2x76	2x60		
ACVL805B	616	546	165970	140118	53	49	C	B			10 x 900	2414,7	209	2x76	2x60		
ACVL805C	675	585	161021	134310	53	49	B	B			10 x 900	3219,6	278	2x90	2x76		
ACVL806B	741	657	199203	168189	54	50	C	B			12 x 900	2901,4	251	2x90	2x76		
ACVL806C	811	703	193276	161231	54	50	B	B			12 x 900	3868,5	334	4x76	2x90		
ACVL807B	866	769	232436	196259	54	50	C	B			14 x 900	3388	292	4x76	2x90		
ACVL807C	949	824	225531	188151	54	50	B	B			14 x 900	4517,4	390	4x76	2x90		
ACVL808B	984	876	265668	224329	55	51	C	B			16 x 900	3874,7	334	4x76	2x90		
ACVL808C	1082	941	257786	215071	55	51	B	B			16 x 900	5166,2	446	4x76	2x90		
ACVQ802B	176	146	42280	32742	40	33	P=370W I=1,2A n=440 min-1	P=200W I=0,5A n=330 min-1			A	A	4 x 900	954,7	83	2x54	2x48
ACVQ802C	188	151	40706	31218	40	33					A	A	4 x 900	1273	110	2x54	2x48
ACVQ803B	265	219	63499	49192	42	35			A	A	6 x 900	1441,4	125	2x76	2x60		
ACVQ803C	283	227	61159	46922	42	35			A	A	6 x 900	1921,9	166	2x76	2x60		
ACVQ804B	354	294	84716	65642	43	36			A	A	8 x 900	1928	167	2x76	2x60		
ACVQ804C	380	304	81612	62625	43	36			A	A	8 x 900	2570,7	222	2x76	2x60		
ACVQ805B	442	366	105934	82091	44	37			A	A	10 x 900	2414,7	209	2x76	2x60		
ACVQ805C	473	380	102065	78327	44	37			A	A	10 x 900	3219,6	278	2x90	2x76		
ACVQ806B	532	438	127151	98540	45	38			A	A	12 x 900	2901,4	251	2x90	2x76		
ACVQ806C	567	455	122517	94030	45	38			A	A	12 x 900	3868,5	334	4x76	2x90		
ACVQ807B	624	509	148369	114989	45	38			A	A	14 x 900	3388	292	4x76	2x90		
ACVQ807C	659	530	142969	109732	45	38			A	A	14 x 900	4517,4	390	4x76	2x90		
ACVQ808B	713	583	169586	131437	46	39			A	A	16 x 900	3874,7	334	4x76	2x90		
ACVQ808C	751	603	163422	125435	46	39			A	A	16 x 900	5166,2	446	4x76	2x90		
ACVR802B	163	115	38187	24463	36	25			P=250W I=0,62A n=380 min-1	P=110W I=0,27A n=240 min-1	A	A	4 x 900	954,7	83	2x54	2x48
ACVR802C	172	115	36487	23035	36	25					A	A	4 x 900	1273	110	2x54	2x48
ACVR803B	245	173	57366	36768	38	27	A	A			6 x 900	1441,4	125	2x76	2x60		
ACVR803C	259	173	54838	34641	38	27	A	A			6 x 900	1921,9	166	2x76	2x60		
ACVR804B	329	232	76545	49073	39	28	A	A			8 x 900	1928	167	2x76	2x60		
ACVR804C	347	232	73188	46246	39	28	A	A			8 x 900	2570,7	222	2x76	2x60		
ACVR805B	410	290	95723	61377	40	29	A	A			10 x 900	2414,7	209	2x76	2x60		
ACVR805C	433	290	91537	57851	40	29	A	A			10 x 900	3219,6	278	2x90	2x76		
ACVR806B	491	348	114901	73681	41	30	A	A			12 x 900	2901,4	251	2x90	2x76		
ACVR806C	519	347	109887	69456	41	30	A	A			12 x 900	3868,5	334	4x76	2x90		
ACVR807B	576	404	134079	85986	41	30	A	A			14 x 900	3388	292	4x76	2x90		
ACVR807C	604	405	128237	81061	41	30	A	A			14 x 900	4517,4	390	4x76	2x90		
ACVR808B	659	461	153257	98290	42	31	A	A			16 x 900	3874,7	334	4x76	2x90		
ACVR808C	687	461	146586	92665	42	31	A	A			16 x 900	5166,2	446	4x76	2x90		

Nominal capacities according to standard ENV327(R404A Tair=25°C, Tcond=40°C, ΔTsubcool<3K, ΔTsuperheat=25K).

*See "General Contents" for more details.

** Energy Efficiency Class: see "General Contents" for more details.

Model	Capacity		Airflow		Lp [dB(A)]*		Motor (3/400V-50Hz)		E.E.C.**		Fans	Surface	Tube volume	Conn.	
	[kW]		[m3/h]		(10m)						N° x D [mm]	m²	dm³	mm	
	Δ	Y	Δ	Y	Δ	Y	Δ	Y	Δ	Y				Inlet	Outlet
Ø 910															
ACVT902B	362	321	123300	100215	62	57	P=3600W I=7,2A n=890 min-1	P=2500W I=4,3A n=7000 min-1	E	D	4 x 900	954,7	83	2x54	2x48
ACVT902C	414	358	118519	95183	62	57			D	D	4 x 900	1273	110	2x54	2x48
ACVT903B	546	483	185176	150573	64	59			E	D	6 x 900	1441,4	125	2x76	2x60
ACVT903C	624	539	178095	143093	64	59			D	D	6 x 900	1921,9	166	2x76	2x60
ACVT904B	722	637	247049	200929	65	60			E	D	8 x 900	1928	167	2x76	2x60
ACVT904C	824	710	237668	191002	65	60			D	D	8 x 900	2570,7	222	2x76	2x60
ACVT905B	917	810	308922	251285	66	61			E	D	10 x 900	2414,7	209	2x76	2x60
ACVT905C	1047	903	297240	238909	66	61			D	D	10 x 900	3219,6	278	2x90	2x76
ACVT906B	1097	972	370794	301640	67	62			E	D	12 x 900	2901,4	251	2x90	2x76
ACVT906C	1254	1083	356811	286816	67	62			D	D	12 x 900	3868,5	334	4x76	2x90
ACVT907B	1268	1129	432666	351995	67	62			E	D	14 x 900	3388	292	4x76	2x90
ACVT907C	1456	1263	416383	334723	67	62			D	D	14 x 900	4517,4	390	4x76	2x90
ACVT908B	1414	1269	494538	402349	68	63			E	D	16 x 900	3874,7	334	4x76	2x90
ACVT908C	1639	1430	475954	382629	68	63			D	D	16 x 900	5166,2	446	4x76	2x90
ACVS902B	298	253	88995	69511	58	53	P=1650W I=3,5A n=860 min-1	P=1100W I=1,8A n=660 min-1	C	C	4 x 900	954,7	83	2x54	2x48
ACVS902C	333	276	85840	66513	58	53			C	B	4 x 900	1273	110	2x54	2x48
ACVS903B	449	381	133648	104416	60	55			C	C	6 x 900	1441,4	125	2x76	2x60
ACVS903C	501	415	128964	99960	60	55			C	B	6 x 900	1921,9	166	2x76	2x60
ACVS904B	590	500	178300	139321	61	56			C	C	8 x 900	1928	167	2x76	2x60
ACVS904C	659	545	172086	133405	61	56			C	B	8 x 900	2570,7	222	2x76	2x60
ACVS905B	751	638	222951	174225	62	57			C	C	10 x 900	2414,7	209	2x76	2x60
ACVS905C	838	694	215207	166849	62	57			C	B	10 x 900	3219,6	278	2x90	2x76
ACVS906B	902	766	267601	209129	63	58			C	C	12 x 900	2901,4	251	2x90	2x76
ACVS906C	1006	833	258328	200293	63	58			C	B	12 x 900	3868,5	334	4x76	2x90
ACVS907B	1050	895	312252	244033	63	58			C	C	14 x 900	3388	292	4x76	2x90
ACVS907C	1175	976	301449	233737	63	58			C	B	14 x 900	4517,4	390	4x76	2x90
ACVS908B	1185	1016	356903	278936	64	59			C	C	16 x 900	3874,7	334	4x76	2x90
ACVS908C	1333	1112	344569	267181	64	59			C	B	16 x 900	5166,2	446	4x76	2x90
ACVL902B	245	190	66406	46512	51	44	P=900W I=2,2A n=640 min-1	P=470W I=1,05A n=440 min-1	B	B	4 x 900	954,7	83	2x54	2x48
ACVL902C	268	202	63954	44448	51	44			B	A	4 x 900	1273	110	2x54	2x48
ACVL903B	370	285	99733	69876	53	46			B	B	6 x 900	1441,4	125	2x76	2x60
ACVL903C	403	303	96086	66798	53	46			B	A	6 x 900	1921,9	166	2x76	2x60
ACVL904B	484	378	133059	93240	54	47			B	B	8 x 900	1928	167	2x76	2x60
ACVL904C	530	407	128217	89147	54	47			B	A	8 x 900	2570,7	222	2x76	2x60
ACVL905B	617	476	166385	116604	55	48			B	B	10 x 900	2414,7	209	2x76	2x60
ACVL905C	673	507	160347	111496	55	48			B	A	10 x 900	3219,6	278	2x90	2x76
ACVL906B	742	573	199711	139967	56	49			B	B	12 x 900	2901,4	251	2x90	2x76
ACVL906C	808	608	192477	133845	56	49			B	A	12 x 900	3868,5	334	4x76	2x90
ACVL907B	868	671	233036	163331	56	49			B	B	14 x 900	3388	292	4x76	2x90
ACVL907C	946	707	224608	156194	56	49			B	A	14 x 900	4517,4	390	4x76	2x90
ACVL908B	986	767	266361	186694	57	50			B	B	16 x 900	3874,7	334	4x76	2x90
ACVL908C	1079	809	256737	178543	57	50			B	A	16 x 900	5166,2	446	4x76	2x90
ACVQ902B	179	148	43087	33517	41	35	P=330W I=0,83A n=440 min-1	P=185W I=0,38A n=330 min-1	A	A	4 x 900	954,7	83	2x54	2x48
ACVQ902C	191	154	41361	31909	41	35			A	A	4 x 900	1273	110	2x54	2x48
ACVQ903B	269	223	64718	50360	43	37			A	A	6 x 900	1441,4	125	2x76	2x60
ACVQ903C	287	231	62150	47962	43	37			A	A	6 x 900	1921,9	166	2x76	2x60
ACVQ904B	359	299	86348	67203	44	38			A	A	8 x 900	1928	167	2x76	2x60
ACVQ904C	385	310	82939	64013	44	38			A	A	8 x 900	2570,7	222	2x76	2x60
ACVQ905B	448	373	107977	84046	45	39			A	A	10 x 900	2414,7	209	2x76	2x60
ACVQ905C	479	387	103728	80065	45	39			A	A	10 x 900	3219,6	278	2x90	2x76
ACVQ906B	540	447	129607	100889	46	40			A	A	12 x 900	2901,4	251	2x90	2x76
ACVQ906C	574	464	124516	96116	46	40			A	A	12 x 900	3868,5	334	4x76	2x90
ACVQ907B	633	519	151236	117731	46	40			A	A	14 x 900	3388	292	4x76	2x90
ACVQ907C	667	540	145305	112168	46	40			A	A	14 x 900	4517,4	390	4x76	2x90
ACVQ908B	723	594	172865	134574	47	41			A	A	16 x 900	3874,7	334	4x76	2x90
ACVQ908C	762	614	166093	128219	47	41			A	A	16 x 900	5166,2	446	4x76	2x90
ACVR902B	165	116	38825	24688	40	30	P=270W I=0,7A n=390 min-1	P=140W I=0,32A n=250 min-1	A	A	4 x 900	954,7	83	2x54	2x48
ACVR902C	175	117	37219	23391	40	30			A	A	4 x 900	1273	110	2x54	2x48
ACVR903B	248	175	58319	37100	42	32			A	A	6 x 900	1441,4	125	2x76	2x60
ACVR903C	263	176	55929	35166	42	32			A	A	6 x 900	1921,9	166	2x76	2x60
ACVR904B	333	234	77812	49511	43	33			A	A	8 x 900	1928	167	2x76	2x60
ACVR904C	353	235	74639	46940	43	33			A	A	8 x 900	2570,7	222	2x76	2x60
ACVR905B	415	292	97305	61922	44	34			A	A	10 x 900	2414,7	209	2x76	2x60
ACVR905C	440	294	93349	58714	44	34			A	A	10 x 900	3219,6	278	2x90	2x76
ACVR906B	497	350	116797	74334	45	35			A	A	12 x 900	2901,4	251	2x90	2x76
ACVR906C	528	352	112058	70488	45	35			A	A	12 x 900	3868,5	334	4x76	2x90
ACVR907B	584	407	136290	86745	45	35			A	A	14 x 900	3388	292	4x76	2x90
ACVR907C	613	410	130767	82262	45	35			A	A	14 x 900	4517,4	390	4x76	2x90
ACVR908B	667	464	155783	99156	46	36			A	A	16 x 900	3874,7	334	4x76	2x90
ACVR908C	698	467	149477	94036	46	36			A	A	16 x 900	5166,2	446	4x76	2x90

Nominal capacities according to standard ENV327(R404A Tair=25°C, Tcond=40°C, ΔTsubcool=3K, ΔTsuperheat=25K).

*See "General Contents" for more details.

** Energy Efficiency Class: see "General Contents" for more details.

Model	Capacity		Airflow		Lp [dB(A)]*		Motor (3/400V-50Hz)		E.E.C.**		Fans	Surface	Tube volume	Conn.	
	[kW]		[m3/h]		(10m)						N° x D [mm]	m²	dm³	mm	
	Δ	Y	Δ	Y	Δ	Y	Δ	Y	Δ	Y				Inlet	Outlet
Ø 1000															
ACVL1002B	340	291	110315	85797	59	54	P=2200W I=4.2A n=670 min-1	P=1500W I=2.7A n=530 min-1	D	C	4 x 900	954,7	83	2x54	2x48
ACVL1002C	378	315	103038	79628	59	54			C	C	4 x 900	1273	110	2x54	2x48
ACVL1003B	512	439	165851	129023	61	56			D	C	6 x 900	1441,4	125	2x76	2x60
ACVL1003C	569	475	155001	119814	61	56			C	C	6 x 900	1921,9	166	2x76	2x60
ACVL1004B	676	577	221385	172247	62	57			D	C	8 x 900	1928	167	2x76	2x60
ACVL1004C	750	625	206962	159997	62	57			C	C	8 x 900	2570,7	222	2x76	2x60
ACVL1005B	860	735	276918	215471	63	58			D	C	10 x 900	2414,7	209	2x76	2x60
ACVL1005C	954	795	258922	200179	63	58			C	C	10 x 900	3219,6	278	2x90	2x76
ACVL1006B	1030	882	332450	258694	64	59			D	C	12 x 900	2901,4	251	2x90	2x76
ACVL1006C	1144	955	310881	240361	64	59			C	C	12 x 900	3868,5	334	4x76	2x90
ACVL1007B	1194	1028	387982	301916	64	59			D	C	14 x 900	3388	292	4x76	2x90
ACVL1007C	1333	1116	362840	280543	64	59			C	C	14 x 900	4517,4	390	4x76	2x90
ACVL1008B	1338	1161	443514	345139	65	60	D	C	16 x 900	3874,7	334	4x76	2x90		
ACVL1008C	1506	1269	414799	320725	65	60	C	C	16 x 900	5166,2	446	4x76	2x90		
ACVQ1002B	257	200	70833	49847	45	38	P=860W I=2,0A n=420 min-1	P=500W I=0,97A n=310 min-1	B	B	4 x 900	954,7	83	2x54	2x48
ACVQ1002C	270	205	64771	45348	45	38			B	B	4 x 900	1273	110	2x54	2x48
ACVQ1003B	387	301	106551	75019	47	40			B	B	6 x 900	1441,4	125	2x76	2x60
ACVQ1003C	407	308	97537	68283	47	40			B	B	6 x 900	1921,9	166	2x76	2x60
ACVQ1004B	507	396	142266	100190	48	41			B	B	8 x 900	1928	167	2x76	2x60
ACVQ1004C	536	414	130300	91217	48	41			B	B	8 x 900	2570,7	222	2x76	2x60
ACVQ1005B	647	503	177981	125360	49	42			B	B	10 x 900	2414,7	209	2x76	2x60
ACVQ1005C	681	517	163063	114151	49	42			B	B	10 x 900	3219,6	278	2x90	2x76
ACVQ1006B	777	605	213694	150530	50	43			B	B	12 x 900	2901,4	251	2x90	2x76
ACVQ1006C	819	619	195825	137084	50	43			B	B	12 x 900	3868,5	334	4x76	2x90
ACVQ1007B	908	709	249408	175700	50	43			B	B	14 x 900	3388	292	4x76	2x90
ACVQ1007C	959	722	228586	160018	50	43			B	B	14 x 900	4517,4	390	4x76	2x90
ACVQ1008B	1031	809	285121	200870	51	44	B	B	16 x 900	3874,7	334	4x76	2x90		
ACVQ1008C	1093	826	261348	182951	51	44	B	B	16 x 900	5166,2	446	4x76	2x90		
ACVR1002B	235	166	62393	39295	43	34	P=670W I=1,4A n=380 min-1	P=330W I=0,67A n=250 min-1	B	A	4 x 900	954,7	83	2x54	2x48
ACVR1002C	244	169	56752	35640	43	34			B	A	4 x 900	1273	110	2x54	2x48
ACVR1003B	354	251	93875	59136	45	36			B	A	6 x 900	1441,4	125	2x76	2x60
ACVR1003C	368	254	85475	53680	45	36			B	A	6 x 900	1921,9	166	2x76	2x60
ACVR1004B	464	337	125355	78975	46	37			B	A	8 x 900	1928	167	2x76	2x60
ACVR1004C	489	341	114197	71718	46	37			B	A	8 x 900	2570,7	222	2x76	2x60
ACVR1005B	592	420	156835	98815	47	38			B	A	10 x 900	2414,7	209	2x76	2x60
ACVR1005C	615	426	142918	89757	47	38			B	A	10 x 900	3219,6	278	2x90	2x76
ACVR1006B	712	504	188313	118653	48	39			B	A	12 x 900	2901,4	251	2x90	2x76
ACVR1006C	739	511	171638	107795	48	39			B	A	12 x 900	3868,5	334	4x76	2x90
ACVR1007B	833	591	219791	138492	48	39			B	A	14 x 900	3388	292	4x76	2x90
ACVR1007C	866	594	200358	125832	48	39			B	A	14 x 900	4517,4	390	4x76	2x90
ACVR1008B	948	676	251270	158331	49	40	B	A	16 x 900	3874,7	334	4x76	2x90		
ACVR1008C	989	676	229079	143870	49	40	B	A	16 x 900	5166,2	446	4x76	2x90		

Nominal capacities according to standard ENV327(R404A Tair=25°C, Tcond=40°C, ΔTsubcool<3K, ΔTsuperheat=25K).

*See "General Contents" for more details.

** Energy Efficiency Class: see "General Contents" for more details.

Alfa V- ACV

Drawings

Model	Dimensions		Weight Kg
	mm		
	A	B	
Ø 800			
ACV_802B	2940	2208	750
ACV_802C	2940	2208	860
ACV_803B	4250	2208	1050
ACV_803C	4250	2208	1250
ACV_804B	5560	2208	1480
ACV_804C	5560	2208	1700
ACV_805B	6870	2208	1850
ACV_805C	6870	2208	2125
ACV_806B	8190	2208	2100
ACV_806C	8190	2208	2500
ACV_807B	9490	2208	2600
ACV_807C	9490	2208	2990
ACV_808B	10800	2208	2980
ACV_808C	10800	2208	3380
Ø 910			
ACV_902B	2940	2208	750
ACV_902C	2940	2208	860
ACV_903B	4250	2208	1050
ACV_903C	4250	2208	1250
ACV_904B	5560	2208	1480
ACV_904C	5560	2208	1700
ACV_905B	6870	2208	1850
ACV_905C	6870	2208	2125
ACV_906B	8190	2208	2100
ACV_906C	8190	2208	2500
ACV_907B	9490	2208	2600
ACV_907C	9490	2208	2990
ACV_908B	10800	2208	2980
ACV_908C	10800	2208	3380
Ø 1000			
ACV_1002B	2940	2208	750
ACV_1002C	2940	2208	860
ACV_1003B	4250	2208	1050
ACV_1003C	4250	2208	1250
ACV_1004B	5560	2208	1480
ACV_1004C	5560	2208	1700
ACV_1005B	6870	2208	1850
ACV_1005C	6870	2208	2125
ACV_1006B	8190	2208	2100
ACV_1006C	8190	2208	2500
ACV_1007B	9490	2208	2600
ACV_1007C	9490	2208	2990
ACV_1008B	10800	2208	2980
ACV_1008C	10800	2208	3380

We reserve the right to change our technical data without prior notice.

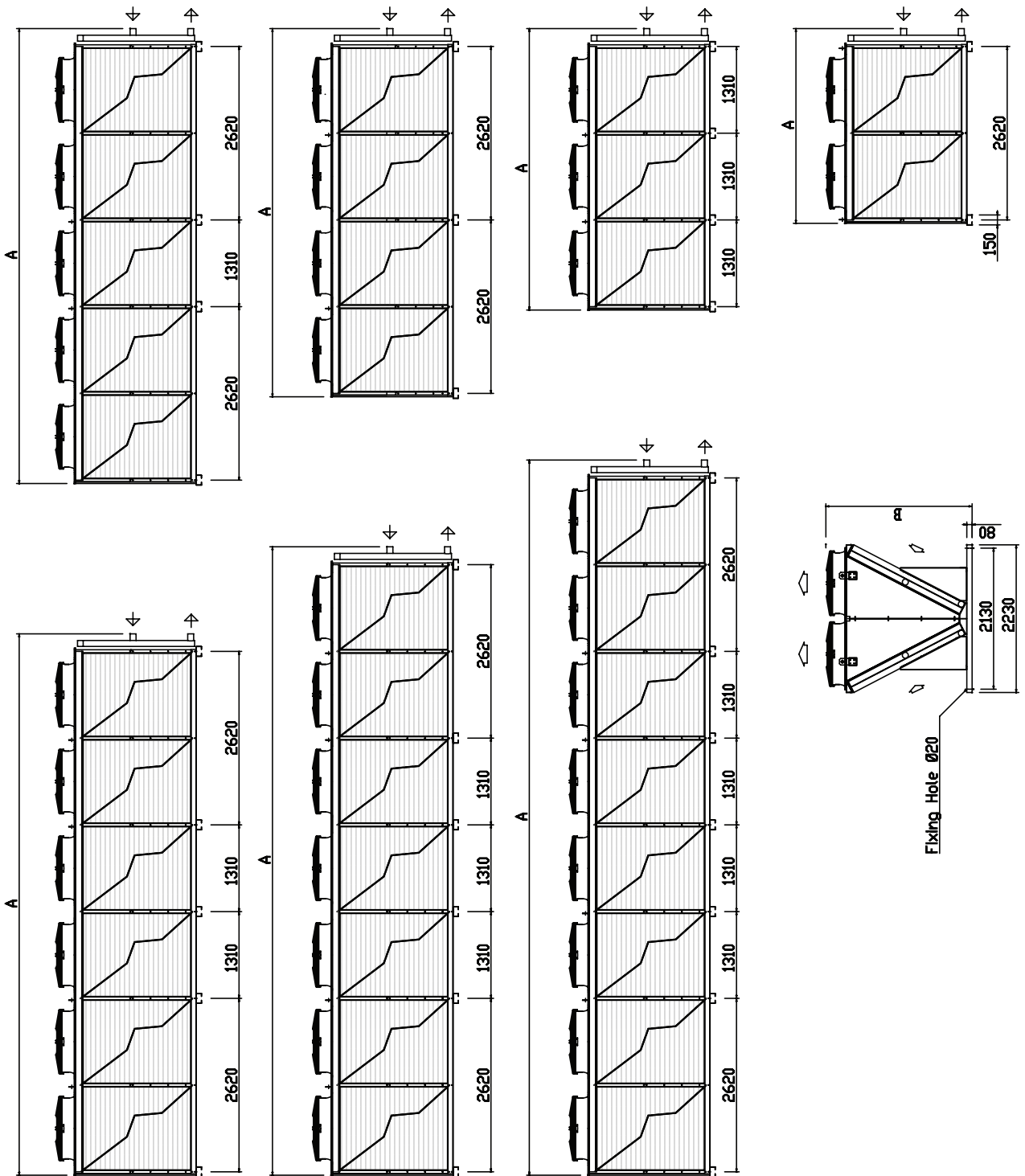

Alfa V- ACV

Options

Motor fans



- (a) Fan motor 400 V/3ph - 60Hz, IP54: S/L/Q/R for Ø 800/910
 (b) Fan motor 460 V/3ph - 60Hz, IP54: S/L/Q/R for Ø 800/910

Model:
 Ø 800 (a,b)
 Ø 910(a,b)

Local safety switch wired

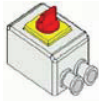

See Electrical Data Page.

Model:
 All Models

Terminal Box

See Electrical Data Page.

Model:
 All Models

Switchboard and cabling

Function

Switchboard for supply and control of fan motors.
 A switchboard can supply up to 8 individual motors or 8 paired motors (i.e. max. of 16 motors).
 Switchboard and cabling are supplied as standard for vertical installation of the unit.
 If you have different needs, please specify these when placing your order.

Operating conditions

Type of installation: External wall mounted
 Protection class: IP55 door closed
 Climate: Normal
 Operating temperature: -10 ÷ +35°C (base) -25 ÷ +50°C (with options)
 Ambient relative humidity: <95%
 Altitude: <1000metres above sea level

Electrical data

Insulating nominal voltage: 690V
 Operating voltage: 3Ph. 400Vac
 Frequency: 50Hz
 Auxiliaries voltage: 24-230V
 Nominal current: Max 80A

Mechanical data

Material: Pre-painted galvanized steel
 Fixing plate: Sheet of steel (min. thickness 15/10 Sendzimir galvanized)
 Gasket: Polyurethane
 Door: opening more than 180°.
 Colour: RAL 7035
 Cable gland: metric ISO

Model:
 All Models

Switchboard Options		
	<p>R anti-condensate resistor 230Vac (operating temperature $-25 \div +35^{\circ}\text{C}$)</p> <p>C cooling fan 230Vac (operating temperature $-10 \div +50^{\circ}\text{C}$)</p> <p>F cooling fan + anti-condensate resistor</p>	<p>Model: All Models</p>
Switchboard with Fan Speed control		
	<p>Switchboard and cabling, including an electronic fan speed controller (equipment that checks and regulates the speed rotation of the fan's motor, keeping the condensing pressure within the range or pre-defined values). Constant control of the fan speed is achieved by variation of the electrical supply by phase-cut, as determined by the probe signal. The fan speed controller comes pre-connected to the switchboard. If you have different needs, please specify these when placing your order.</p>	<p>Model: Ø 630 Ø 800 Ø 910</p>
Switchboard with Fan Step control		
	<p>Switchboard and cabling including an automatic on/off switch that checks and regulates the rotation speed of the fan's motor, keeping the condensing pressure within the range or pre-defined values. Control of the fan speed is achieved by variation of the electrical supply by the ON/OFF device, as determined by the probe signal. The fan step controller comes pre-connected to the switchboard. If you have different needs, please specify these when placing your order.</p>	<p>Model: All Models</p>
Switchboard with Frequency Converter (Inverter)		
	<p>See Electrical Data Page.</p>	<p>Model: All Models</p>
Coil Treatment / Material		
	<p>Thermoguard for industrial or sea coast application.</p> <p>Aluminium fins, pre-coated.</p> <p>Copper fins.</p> <p>Application Use: More information on corrosion prevention can be found in the Miscellaneous section.</p>	<p>Model: All Models</p>
Multi-circuits		
	<p>All models are suitable for multi-circuits, enabling more than one refrigeration system to operate with a single condenser.</p>	<p>Model: All Models</p>
Sub-cooling circuit		
	<p>Sub-cooling is achieved by the use of an integrated sub-cooling section which covers approximately 10% of the coil surface. This provides $6-7^{\circ}\text{C}$ max. of sub-cooling at the standard rate condition of 15K. The overall effect on the condensing capacity is a reduction of 10%. However, the overall heat rejection inclusive of sub-cooling capacity will only be reduced by 5%.</p>	<p>Model: All Models</p>
Non-standard fin spacing		
	<p>The standard fin spacing is 2.1mm.</p> <p>Alternative: 2.5mm and 3.2mm.</p>	<p>Model: All Models</p>
Spray water		
	<p>Consisting of a pipe system with several fitted spraying nozzles that nebulise water in the air suction of the coil. Spray water comes mounted on delivery.</p>	<p>Model: All Models</p>
Finned coil grid		
	<p>To protect the coil from accidental damage by external objects. Mesh: 40 mm x 40 mm.</p>	<p>Model: All Models</p>

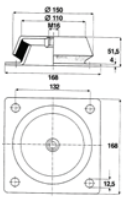
Vibration Dampers								Model: All Models
	Type	H mm	A mm	B mm	C mm	D mm	Weight Kg	
	Single Row	51.5	132	168	M16	12.5	2.15	
Nuts and bolts are not included with these dampers.								

Alfa V- ACV

Electrical Data

Safety Switch

Function

Local safety switch and cabling for each electric fan motor.

General data

Power Supply:

- 400VAC, 50/60Hz
- Max fuse 16A

Number of poles: 3P

Cabinet Material: Plastic Case

Cabinet Colour: Grey (Yellow-Red Knob)

Protection Class: Min IP65

Ambient Temp.: min. -25°C, max. +50°C

Weight: Approx. 0.4Kg

Dimensions

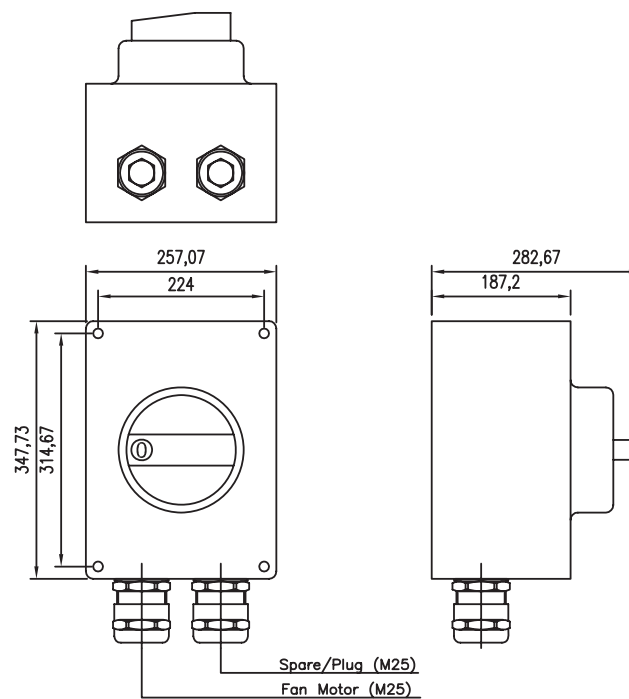

Terminal Box

Function

Connection box for electric fan motor

General data

Material: Plastic

IP Protection Class: Min RAL 7035

Colour: Grey RAL 7035

Insulation Class: II

Ambient Temp.: min. -40°C, max. +80°C

Weight: Approx. 0.5Kg.

Dimensions

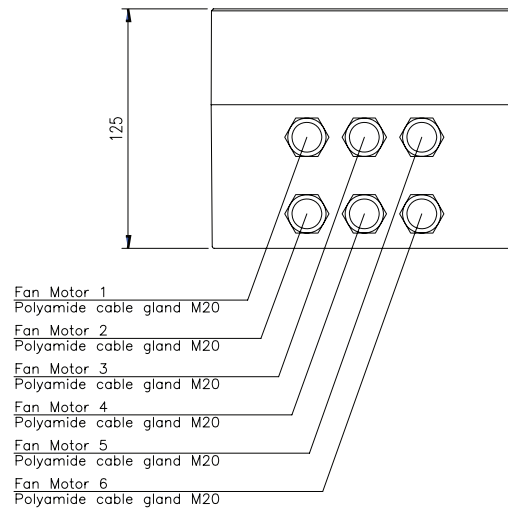
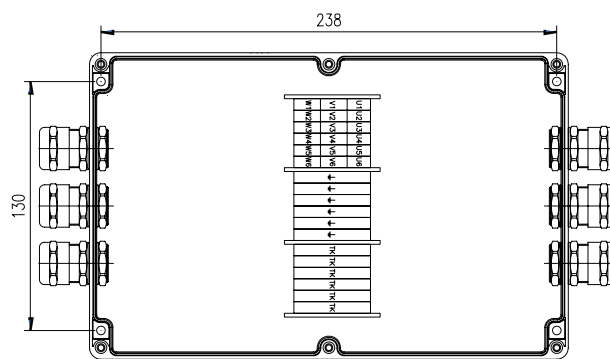

Current Distribution

Function

Current distributors are available as optional accessories. Numerous fans can be connected. In combination with Fcontrol frequency inverters, we can deliver the current distribution with both main switch and bypass function. Features: The current distributor is equipped with plastic housing IP54 and motor protection units STDT16E with status signal contacts ZB. It is possible to lock the motor protection units with a padlock and use them as repair switches. Fans are directly connected to the motor protection units. Line protection is guaranteed through the integrated short-circuit release. Terminals for supplying the controller output are also integrated. The current distributors are suitable for external mounting (e.g. direct mounting at refrigeration units). It's easy to see the switch position of the motor protection units through the coloured, transparent plastic door.

General data

Current distributor with main switch and bypass function:

- The controller is supplied by the current distributor
- Main switch: 100% - 0 -1
- In position 100%, the connection to the controller output is switched off. This version is for Fcontrol frequency inverters .
- Rated current: Up to 80A

Dimensions

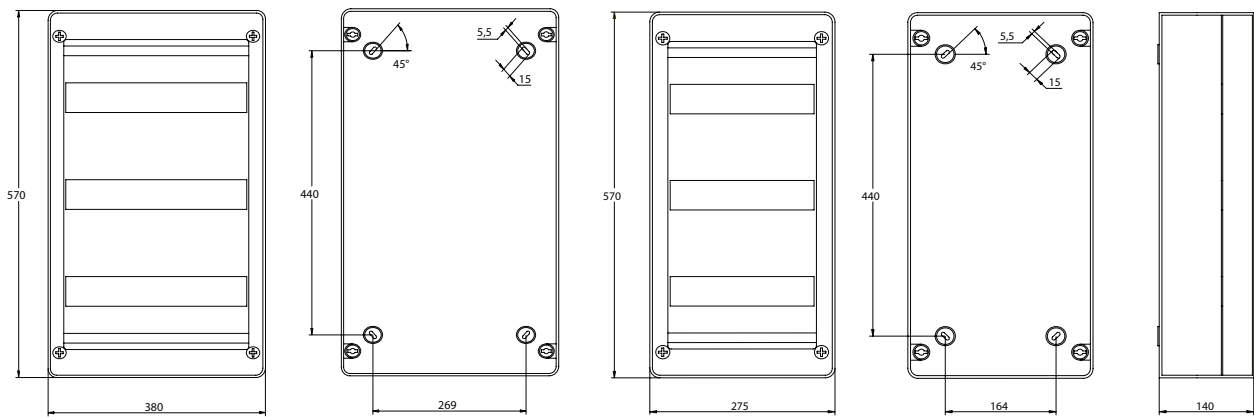

Electric wiring diagram

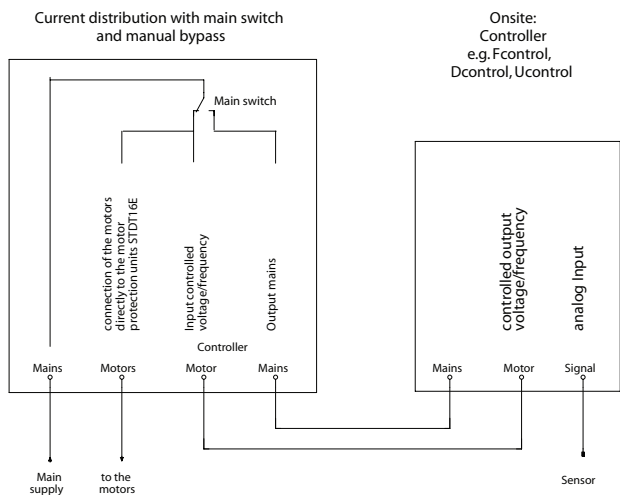

Frequency Converter (Inverter)

Function

Frequency inverter (incl. sine filter) for 3~ motors. Universal controller for refrigeration and air conditioning line input 3~ 208-480V, housing IP54, internal display.

- Speed controller with manual adjustment of output voltage at the unit or via external signal, 2-step operation;
- Temperature control for liquid coolers;
- Pressure control refrigeration (input for refrigerant) for: condensers, dual-circuit condensers;

General data

Equipment/Function

- Integrated SINEFILTER between phase to phase and phase to earth.
- Absolute parallel operation of fans, with no risk of damage to the motor. **Screened motor cables are not required.**
- Integrated process controller (PID free programmable).
- LCD multifunction display with plain language text.
- 2x Analogue Input (0-10 V, 0-20 mA, 4-20 mA, temperature sensor type TF):
 - Analogue 1 for setting of sensor signal.
 - Analogue 2 programmable function for: external set-point, difference value to sensor 1, comparison value (dual-circuit condenser), averaging, and setpoint lowering according to outdoor temperature.
- 1x output 0-10V, programmable function: Constant voltage, proportional modulation, proportional input signal, group control, controller 2.
- 2x digital inputs, programmable function: enable (on / off), external fault, limit output, input 1/2, set-point 1/2, setting internal / external, automatic control / speed manual, reverse control function ("heating" / "cooling"), reset, setting max. speed.
- 2x relay outputs, programmable function: operating indication, fault indication, external fault from digital input, limit modulation, limit input signal, limit offset (deviation actual value setpoint), group control .
- Total motor protection using thermocontact / thermistor connection.
- Interface system with RS485 Interface (MODBUS) or LON® is another alternative option.

Technical data

- Line voltage 3~ 208 BND_480V (-15% / +10%), 50/60Hz.

Rated current*/A	4	8	13	18	22	32	40
Max. line fuse/A	10	10	16	20	25	35	50
Max. heat dissipation*/W	130	210	350	440	540	950	1.100
Weight/Kg	8.8	9.0	22.8	25.4	28.1	29.5	31.8

*at line voltage 400V / 50Hz (for FXDM40A rated current - only possible for fans with $\cos \phi < 0.8$).

- Maximum output frequency 100Hz (for FXDM40, max. 60Hz).
- Clock frequency 16 kHz.
- Max. permissible ambient temperature 40°C (up to 55°C with derating).
- Voltage supply for sensors +24V $\pm 20\%$ (I_{max} 120 mA).
- Permissible rel. humidity 85% with no condensation .
- Interference emission EN 61000-6-3 1 (unshielded motor cable).
- Interference immunity EN 61000-6-2.

Settings

- Quick start-up with pre-programming modes.
- Set-point 1, set-point 2, manual mode.
- Min. and max. speed, speed limitation e.g. for night operation.
- Group control (via relay or 0-10V signal output).
- Limits: Modulation, input signal, offset (deviation set to actual value).
- Set protection, save user settings.
- Readout events memory (checking the fault log).
- Masking up to 3 settable speed ranges.
- Minimum rate of air on / off.
- Edge frequency, max. frequency / voltage, start voltage.
- U/f characteristics: quadratic or linear.
- Menu language: English, German, Italian, Swedish, etc.
- Inverting: Inputs analogue and digital, analogue out, relays.

Dimensions

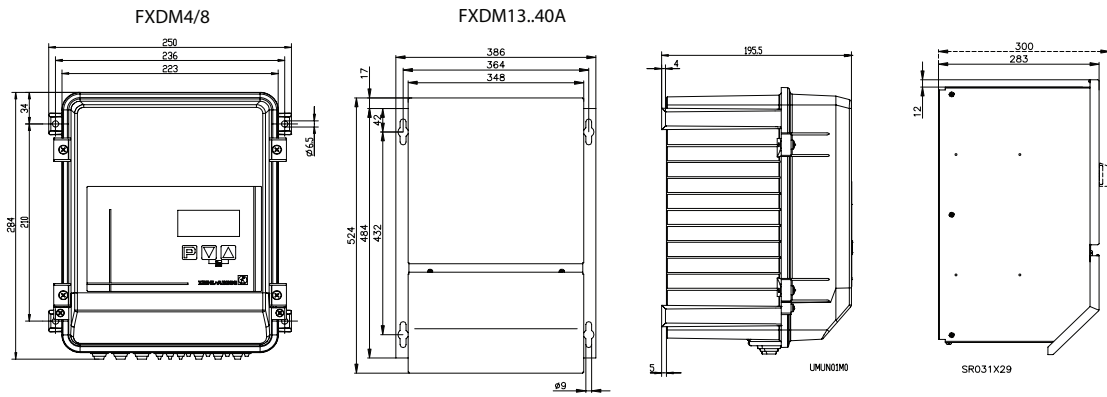

Electric wiring diagram

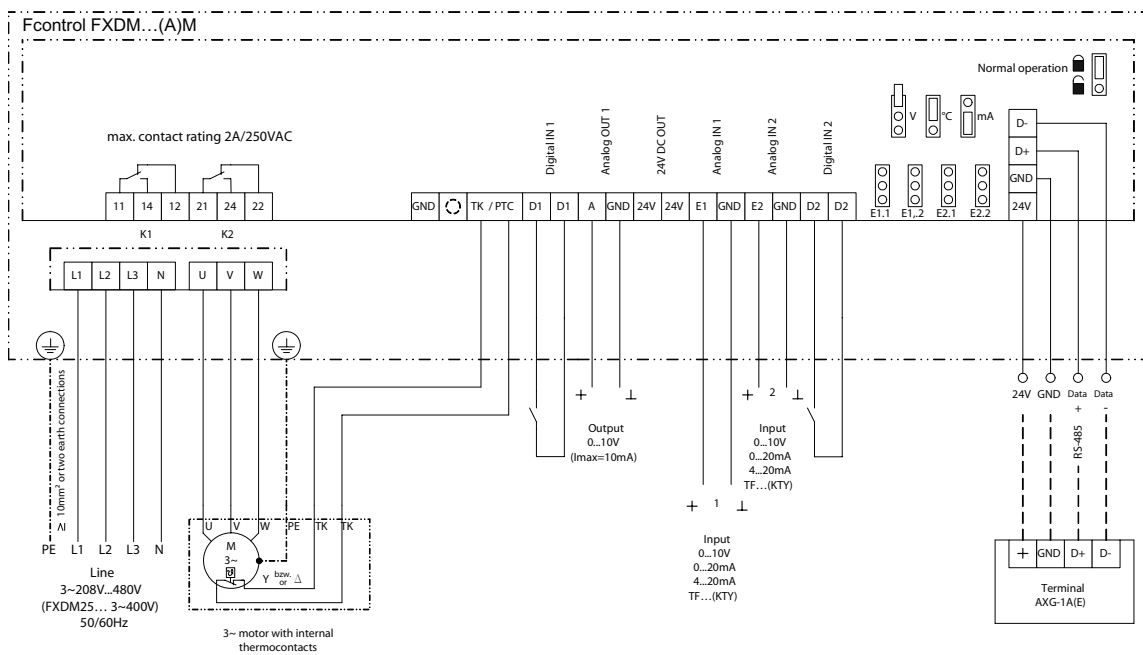

⚠ Only in special version suitable for IT network!

Alfa V- ACV

Code description

Code No.

	1	2	3	4
ACV	S	80	2	A

1) Type of noise level (number of dB(A) to reduce compared with "base" version)

	Standard noise level	Low noise level	Quiet noise level	Residential noise level
	S*	L*	Q*	R*
Fan Ø 800/910/1000 mm	std	-7	-17	-20

2) Fan diameter Ø

80	800 mm
90	910 mm
100	1 000 mm

3) Number of Fans (* available in this version)

1	Ø 800/910/1000 mm
2	
3	
4	
5	
6	
7	
8	

4) Number of coil rows

B	3
C	4

General Alfa Select Air Legend

Description 1		Description 2	
D	D fan cabling (three phase)	BSFT	Basic Switch Board + Speed Control Temp. + Signal
Y	Y fan cabling (three phase)	BI	Basic Switch Board + Frequency Converter (Inverter)
D/Y	D/Y fan cabling (three phase), single speed fan motor	BSI	Basic Switch Board + Frequency Converter (Inverter) + Signal
S	Single phase	C	Switch Board + Cooling fan
P	Packaged on a pallet	R	Switch Board + Resistor
CR	Packaged in a crate	F	Switch Board + Cooling fan + Resistor
BO	Packaged in a box	PT	Ammonia pump top
Feet	Feet-mounted	PB	Ammonia pump bottom
SW	Safety Switch	AL	Aluminium casing
CB	Terminal Box	SS	Stainless Steel casing
B	Basic Switch Board	AP	Pre-painted Aluminium casing
BS	Basic Switch Board + Signal	PL	Plastic casing
BP	Basic Switch Board + Step Control Pressure	E	Electrical defrost
PT	Basic Switch Board + Step Control Temperature	LE	Low Electrical defrost
BSP	Basic Switch Board + Step Control Pressure + Signal	A	Air Defrost
BST	Basic Switch Board + Step Control Temp. + Signal	HG	Hot Gas Defrost
BFP	Basic Switch Board + Speed Control Pressure	HG+E	Hot Gas Defrost + Electrical Defrost on drip tray
BFT	Basic Switch Board + Speed Control Temperature	W	Water Defrost
BSFP	Basic Switch Board + Speed Control Pres. + Signal	W+E	Water Defrost + Electrical Defrost on drip tray
		AL	Aluminium fin
		CU	Copper fin
		PR	Pre-coated fin
		SS	Stainless steel tube
		TH	Thermoguard treatment
		CF	Cataphoresis treatment
		SC	Sub-cooling circuit
		kW	Spray water kit
		FL	Flanges
		FH	Fan ring heater
		IS	Insulated Drip Tray
		RH	Reheating coil
		SR	Air socket adapter ring
		CW	Air throw fan cowling
		ER	120° elbow reducer
		HN	Hinged fan cowling

Note: valid for the entire product range

Centrifugal Units

General Content

General Features

The Alfa Laval centrifugal condenser range is suitable for use in all refrigeration and air conditioning applications. All units can be built for either horizontal or vertical discharge, with vertical coils and single bank modules from 1 to 4 fans long. The range is designed for both outdoor and indoor operation. Inducted air inlets and outlets must be free from any obstructions to airflow and inlets must not be directed at any heat sources. Inlet and outlet air paths must be arranged so that no discharge air can be drawn into the coil. For discharge air, the ducting must be straight, parallel and free from obstruction or positioned at least 2 metres from the discharge spigot.

Certifications and reliability

Alfa Laval quality systems fully comply with ISO 9001, and all of our products are manufactured in strict accordance with CE regulations.

Capacity

The standard conditions are in accordance with EN 327 (R404A, T. air = 25°C, T.cond.= 40°C, ΔT sub-cool < 3K, ΔT superheat = 25K).

How to work out the condenser's capacity:

$$Q_c = Q_f \times Fr \times F1 \times F2 \times F3 \times F4 \times F5 \times F6$$

Qc = Condenser capacity

Qf = Evaporator capacity

Fr = Condensing Temp (Tc) and evaporating Temp factor. (Te).

F1 = Compressor factor

F2 = Refrigerant factor

F3 = ΔT factor (15/ΔT)

F4 = Altitude factor

F5 = Fin material

F6 = Ambient temperature factor

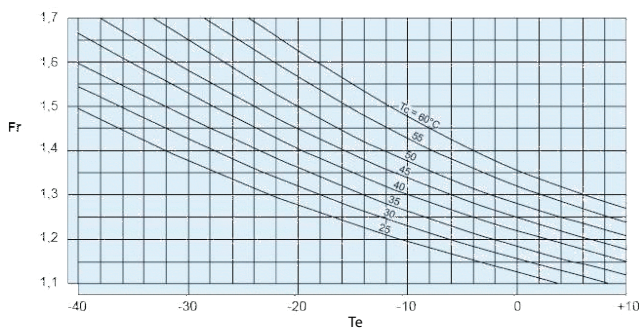

Compressor	Open	Semi-hermetic	Hermetic
F1	1	1,08	1,14

Refrigerant	R507A	R404A	R134a	R22	R407C
F2	1	1	0,93	0,96	0,87

Altitude (m)	0	500	1000	1500	2000
F4	1	1,028	1,06	1,09	1,12

Fin material	Al	Al Prv	Cu
F5	1	1,03	0,97

Ambient Temp.	15	20	25	30	35
F6	0,975	0,988	1,00	1,013	1,026

Tube Protection

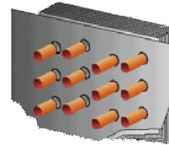

Due to the thermal expansion of the copper pipes, all metal sheets are equipped with an aluminium plate with collars. This plate supports the tube and therefore the pipes must not come into contact with the metal sheets. With this solution, the vibrations and thermal expansion are absorbed by the aluminium sheet. Leaks caused by friction cannot occur. The rigidity of the coil is sustained effectively.

Energy Efficiency Class

Energy efficiency class of air cooled condensers		
Class	Energy consumption	R
A	Extremely low	R>110
B	Very low	70≤R<110
C	Low	45≤R<70
D	Medium	30≤R<45
E	High	R<30

R = Condenser capacity (ΔT15K) / motor power consumption.

Test and cleaning

The coils are cleaned and dehydrated in order to remove any traces of oil.

Each heat exchanger undergoes a pressure and leak test with dry air at 34 bar, before being supplied with a nitrogen pre-charge.



Sound Data

The sound pressure level is based on the calculation (according to EN 13487) of the sound pressure level on the surface of a cuboid area which is at a 10 metre distance and is parallel to the reference envelope of the sound source. (Standard sound pressure level; annex C EN 13487)

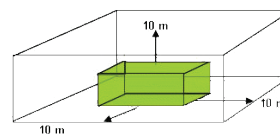

Sound pressure correction for distances other than 10 metres.

Distance (m)	2	3	4	5	7	10	15	20	30	40	50	60	80
Correction dB(A)	11	8,5	7	5	2,5	0	-3	-5,5	-9	-11	-12	-14	-16

Sound pressure level for several fans at nominal speed rating.

N° units	2	3	4	5	6	7	8	9	10
dB(A)	3	5	6	7	8	8,5	9	9,5	10

Guarantee

All our products are protected under warranty for 18 months from the shipping date. If a defect should occur within the warranty period, please return the equipment or part to our factory free of charge where we will repair or replace the goods, depending on what is required. Unfortunately, We cannot take responsibility for damage caused by the misuse or incorrect installation of our products. The brochure is subject to technical changes without prior notice

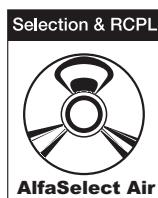

We recommend that you use the Alfa Select Air software for a precise thermal and mechanical design.



CRC/CRI

Product description

Application

The Alfa Laval Condenser can be used in refrigeration and air conditioning equipment.

Standard design

Coil

The heat exchanger provides excellent heat transfer with minimal refrigerant charge as a result of the new fin corrugation developed by Alfa Laval in combination with advanced cross-fin tubes. The heat exchanger is manufactured from aluminium fins and copper tubes with nominal diameter 3/8" (for series CRC), and nominal diameter 1/2" (for series CRI). The fin spacing is 2.1mm.

Casing

Casing is made of galvanized steel sheets. The sturdy frame design provides greater rigidity making it an ideal choice for heavy applications. Can be made of stainless or galvanized steel AISI 304 with optimised length.

Options

- Local safety switch wired
- Multi-circuits: total capacity split in multiple compressor lines
- Sub-cooling circuits
- Thermoguard Treatment
- Pre-coated aluminium fins
- Copper fins

Fans

Low noise level, double suction centrifugal fans, with separate drive via multiple belt and motor rails.

For air temperatures lower than +20°C, the full load current (FLC) can be calculated using the correction factor table. The overload protectors should have a 20% margin to accommodate fan motor supplier variations.

T [°C]	20	10	0	-10	-15	-20	-25	-30
Fc	1	1,04	1,08	1,12	1,14	1,16	1,18	1,2



Model	Capacity	Airflow	Lp[dB(A)]* (10m)	Motor	Fans	RPM	SUP	Int. Vol.	Conn. In	Conn. out
	kW	m³/h		N° x Kw	N°	1/min	m²	dm³	mm	
50 Pa										
CRC-17	19,5	4900	45	1 x 0,55	1	670	39	6	22	16
CRC-23	23	5200	48	1 x 0,75	1	780	58,6	9	22	16
CRC-31	34,4	8400	47	1 x 1,1	1	560	76,5	11	28	22
CRC-41	40,5	9000	50	1 x 1,5	1	630	114,8	12	28	22
CRC-58	60,6	14800	53	1 x 2,2	1	530	127,9	19	35	28
CRC-73	71,3	15900	55	1 x 3	1	600	191,8	29	35	28
CRC-92	92,4	20500	53	1 x 4	2	670	255,8	38	42	28
100 Pa										
CRC-17	18,2	4500	45	1 x 0,55	1	710	39	6	22	16
CRC-23	22	4900	48	1 x 0,75	1	830	58,6	9	22	16
CRC-31	32,8	7900	47	1 x 1,1	1	600	76,5	11	28	22
CRC-41	38,7	8500	50	1 x 1,5	1	670	114,8	12	28	22
CRC-58	58,4	14100	53	1 x 2,2	1	560	127,9	19	35	28
CRC-73	69	15300	55	1 x 3	1	630	191,8	29	35	28
CRC-92	89	19600	53	1 x 4	2	710	255,8	38	42	28
150 Pa										
CRC-17	17	4100	45	1 x 0,55	1	780	39	6	22	16
CRC-23	20,7	4600	48	1 x 0,75	1	890	58,6	9	22	16
CRC-31	31	7400	47	1 x 1,1	1	630	76,5	11	28	22
CRC-41	37	8100	50	1 x 1,5	1	710	114,8	12	28	22
CRC-58	55,8	13400	53	1 x 2,2	1	600	127,9	19	35	28
CRC-73	66,6	14700	55	1 x 3	1	670	191,8	29	35	28
CRC-92	85,7	18800	53	1 x 4	2	750	255,8	38	42	28

Nominal capacities according to standard ENV327(R404A Tair=25°C, Tcond=40°C, ΔTsubcool<3K, ΔTsuperheat=25K).

*See the "General Contents" for more details.

Model	Capacity	Airflow	Lp [dB(A)]* 10m	Motor	Fans	RPM	SUP	Int. Vol.	Conn. In	Conn. out
	kW	m³/h		N° x Kw	N°	1/min	m²	dm³	mm	
50 Pa										
CRI-2115	109,6	33200	55	2 x 3	2	560	206,1	34	42	35
CRI-2130	122,4	32400	55	2 x 3	2	600	274,8	45	42	35
CRI-2150	129,8	31600	55	2 x 3	2	600	343,4	56	48	35
CRI-3175	163,7	49700	57	3 x 3	3	560	309,1	50	48	42
CRI-3200	183,4	48500	57	3 x 3	3	600	412,1	67	54	42
CRI-3220	194,7	47300	57	3 x 3	3	600	515,2	84	54	42
CRI-4240	219,7	66300	58	4 x 3	4	560	412,1	83	60	48
CRI-4270	245,2	64700	58	4 x 3	4	600	549,5	110	60	48
CRI-4290	260	63100	58	4 x 3	4	600	686,9	125	60	48
100 Pa										
CRI-2115	106,8	32000	56	2 x 3	2	600	206,1	34	42	35
CRI-2130	119	31200	56	2 x 3	2	630	274,8	45	42	35
CRI-2150	125,8	30400	56	2 x 3	2	630	343,4	56	48	35
CRI-3175	159,7	47900	58	3 x 3	3	600	309,1	50	48	42
CRI-3200	178,3	46700	58	3 x 3	3	630	412,1	67	54	42
CRI-3220	188,8	45600	58	3 x 3	3	630	515,2	84	54	42
CRI-4240	214,1	63900	59	4 x 3	4	600	412,1	83	60	48
CRI-4270	238,3	62300	59	4 x 3	4	630	549,5	110	60	48
CRI-4290	252	60700	59	4 x 3	4	630	686,9	125	60	48
150 Pa										
CRI-2115	104,1	30800	57	2 x 3	2	630	206,1	34	42	35
CRI-2130	115,5	29900	57	2 x 3	2	630	274,8	45	42	35
CRI-2150	122	29200	57	2 x 3	2	670	343,4	56	48	35
CRI-3175	155,7	46100	59	3 x 3	3	630	309,1	50	48	42
CRI-3200	173,2	44900	59	3 x 3	3	630	412,1	67	54	42
CRI-3220	183	43800	59	3 x 3	3	670	515,2	84	54	42
CRI-4240	208,6	61500	60	4 x 3	4	630	412,1	83	60	48
CRI-4270	231,4	59900	60	4 x 3	4	630	549,5	110	60	48
CRI-4290	244	58400	60	4 x 3	4	670	686,9	125	60	48

Nominal capacities according to standard ENV327(R404A Tair=25°C, Tcond=40°C, ΔTsubcool<3K, ΔTsuperheat=25K).

*See the "General Contents" for more details.

CRC/CRI

Drawings

Model	Dimensions (mm)			Weight Kg
	A	B	C	
CRC 50/100/150 Pa				
CRC-17	1102	735	953	152
CRC-23	1102	735	953	178
CRC-31	1502	935	1043	208
CRC-41	1502	935	1043	227
CRC-58	1922	1135	1173	274
CRC-73	1922	1135	1173	303
CRC-92	1922	1435	1173	365

We reserve the right to change our technical data without prior notice.

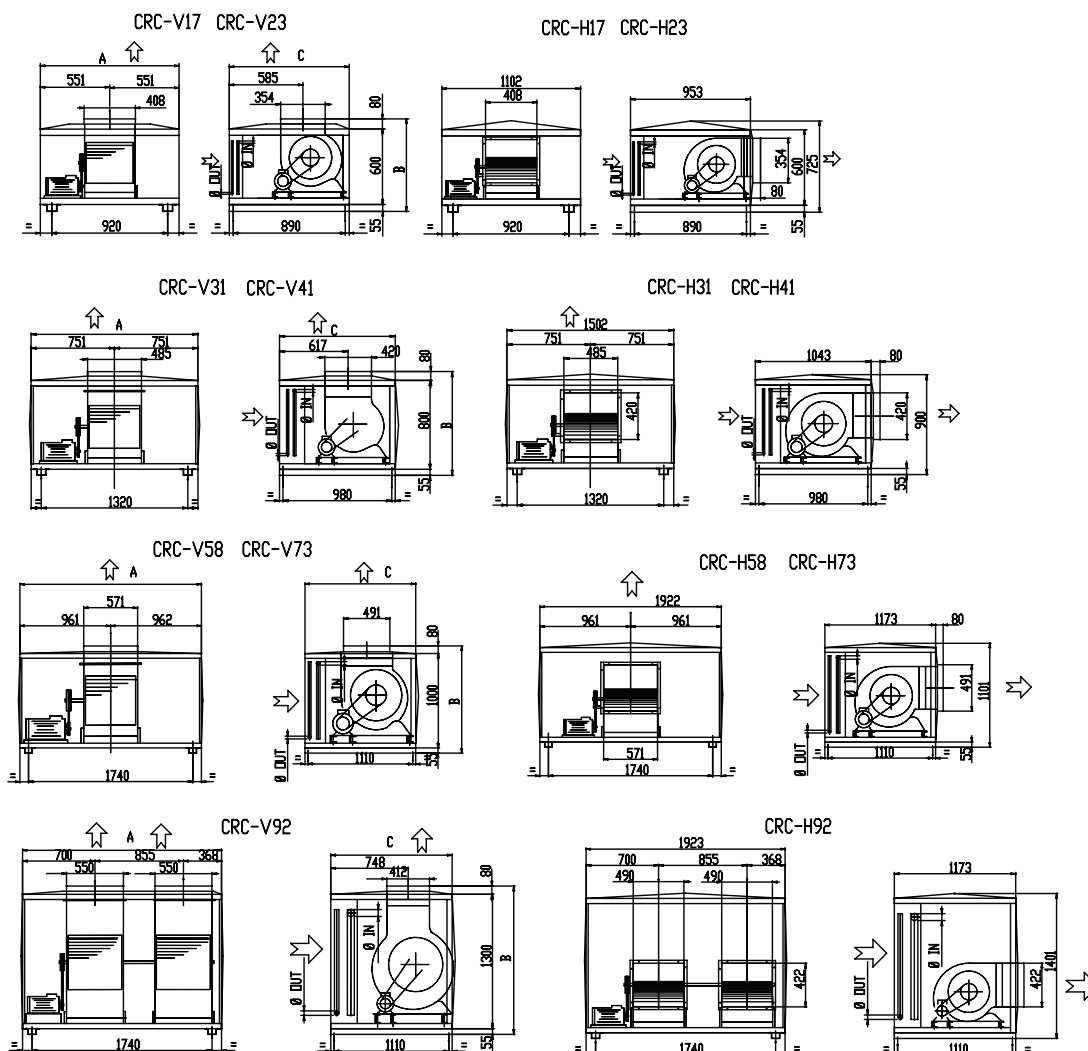

Model	Dimensions (mm)			Weight Kg
	A	B	C	
CRI 50/100/150 Pa				
CRI-2115	2130	1560	1300	472
CRI-2130	2130	1560	1300	502
CRI-2150	2130	1560	1300	534
CRI-3175	3155	1560	1300	708
CRI-3200	3155	1560	1300	754
CRI-3220	3155	1560	1300	795
CRI-4240	4180	1560	1300	946
CRI-4270	4180	1560	1300	1011
CRI-4290	4180	1560	1300	1057

We reserve the right to change our technical data without prior notice.

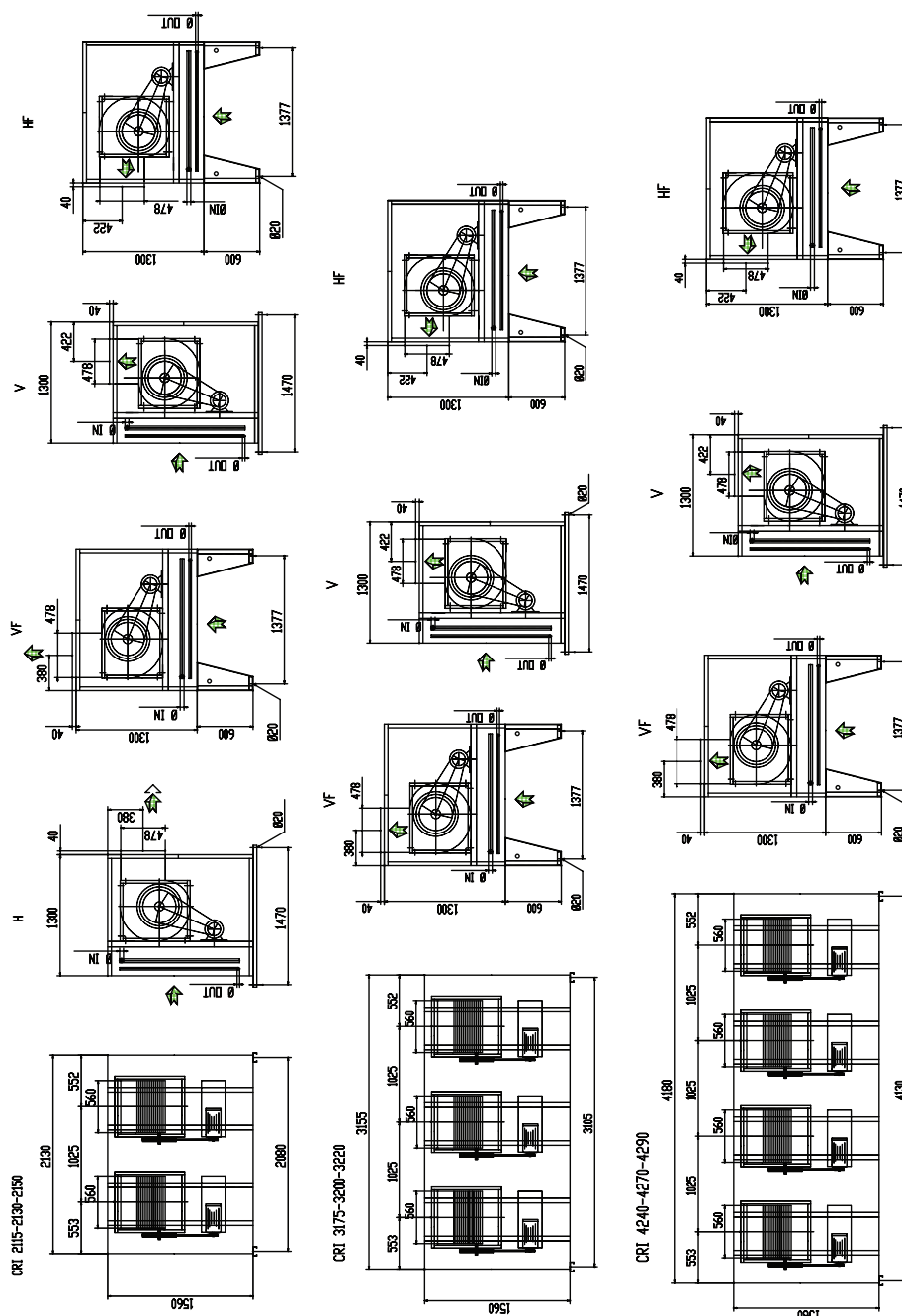

CRC/CRI

Options

Local safety switch wired

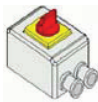

Local safety switch and cabling for each electric fan motor. Plastic covering box, IP65, nominal current 16A – 3 phases, insulated voltage 600V. Material / Colour: Polycarbonate grey (yellow-red handle)
 Mechanical duration: 20,000 operations. Operating temperature: -10°C, + 50°C Reference and standard CE/UL/CSA. Per fan.

Coil Treatment / Material

Thermoguard for industrial or marine application.
 Pre-coated aluminium fins.
 Copper fins.
 Application: More information on corrosion prevention can be found in the Miscellaneous section.

Multi-circuits

Split the capacity and connect additional compressors

Sub-cooling circuits

Additional circuit to further cool the condensate

V/H flow with feet

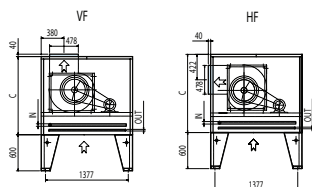

Vertical Feet (VF).
 Horizontal Feet (HF)

Model:
 CRI
 3175
 3200
 3220

CRC/CRI

Electrical Data

Safety switch

Function

Local safety switch and cabling for each electric fan motor.

General data

Power Supply:

- 400VAC, 50/60Hz
- Max fuse 16A

Number of poles: 3P

Cabinet Material: Plastic Case

Cabinet Colour: Grey (Yellow-Red Knob)

Protection Class: Min IP65

Ambient Temp.: min. -25°C, max. +50°C

Weight: Approx. 0.4Kg

Dimensions

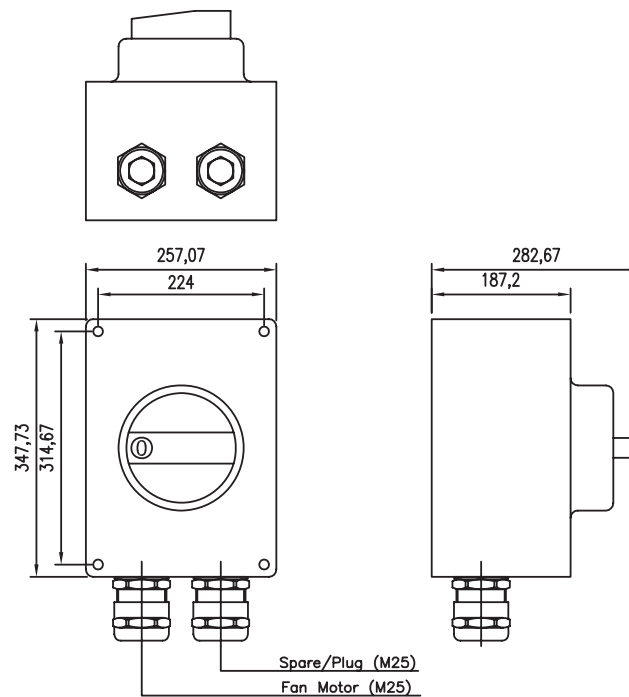

CRC/CRI
Code description

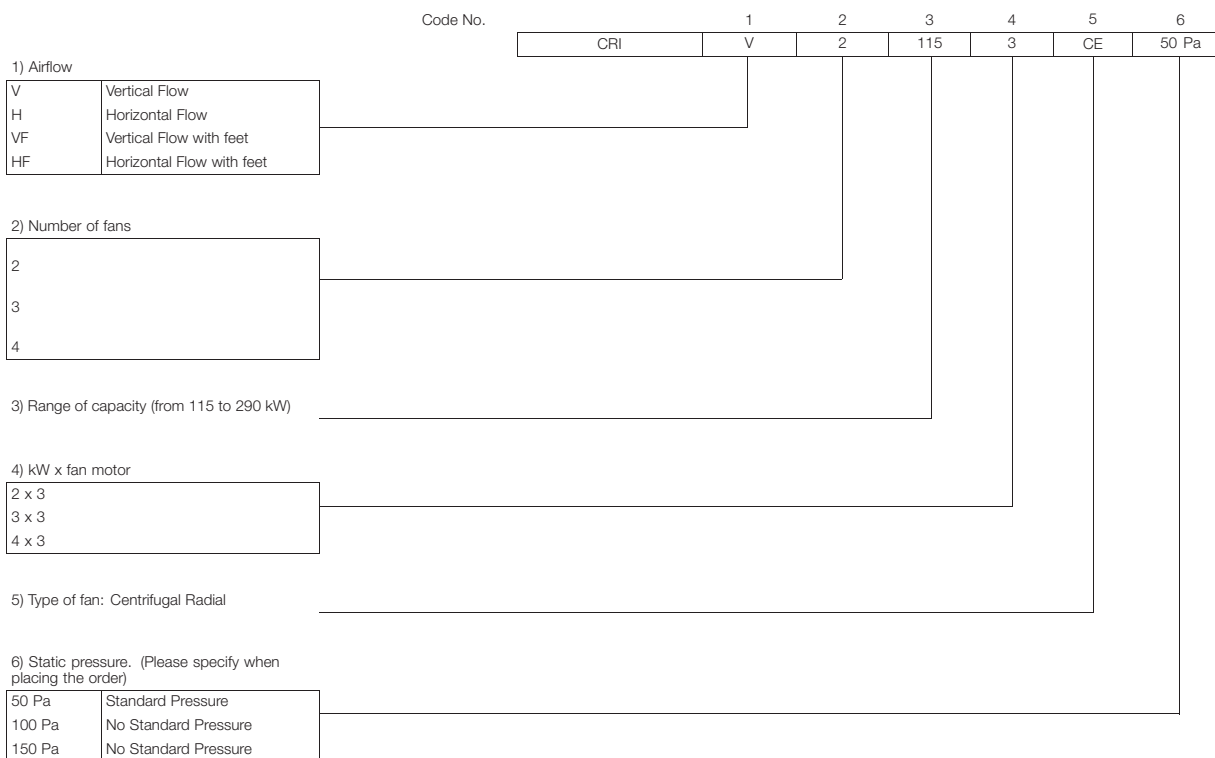
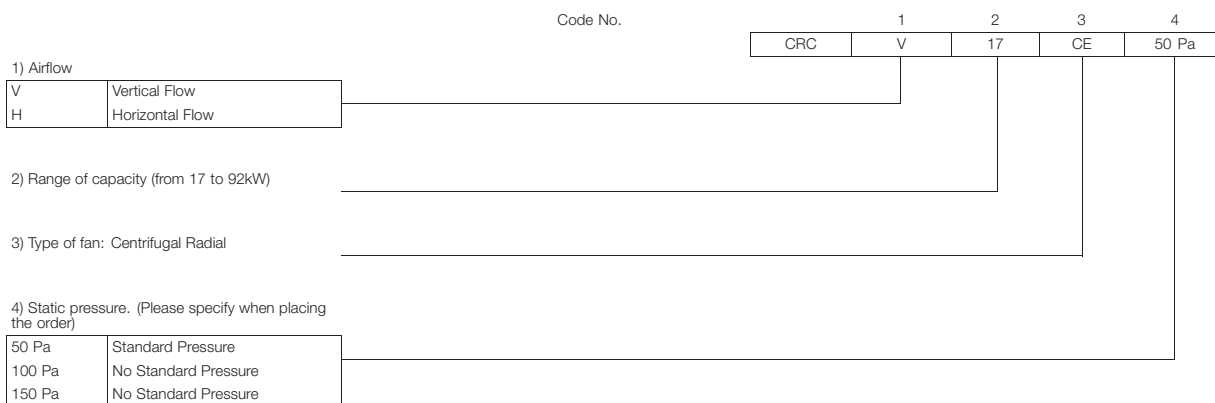

AlfaBlue Dry Coolers

General Content

General Features

A dry cooler is a forced convection air-cooled fluid cooler, designed for outdoor installation. Air is forced over a finned coil which contains the working fluid such as water or a water and glycol mix. All products are designed to satisfy both commercial and industrial refrigeration, air conditioning, and retail refrigeration. Dry coolers are available in the following versions:

- Vertical installation (V)
- Horizontal installation (H)

Relative footprint, low consumption and low noise levels are the keys to this series' success.

Certifications and reliability

All Dry coolers are guaranteed by Eurovent "Certify All". Alfa Laval quality systems fully comply with ISO 9001, and all of our products are manufactured in strict accordance with CE regulations.

Capacity

The standard conditions stated in the catalogue are in accordance with EN 1048 (water, T_{air}= 25°C, T_{in}= 40°C, T_{out}= 35°C). All models have many circuiting options which can be selected to optimise duty with required fluid pressure drops and flow rates. Due to the multiple combinations of temperatures, flow rates and working fluids that can be encountered, it is not possible to display all the capacities in the catalogue.

How to determine the dry cooler's capacity:

Capacity required (e.g. 34%) = Nominal Capacity. (water) x 1.07 x F1 x F2

Altitude (m)	0	500	1000	1500	2000
F1	1	1,028	1,06	1,09	1,12

Fin material	Al	Al Prv	Cu
F2	1	1,03	0,97

Against Freezing

Given that the tubes are permanently in a horizontal position, it cannot be guaranteed that they drain completely when stoppages occur. As a result of this, a dry cooler containing water must be protected against freezing with an adequate amount of glycol.

Tube Protection



Due to the thermal expansion of the copper pipes, all metal sheets are equipped with an aluminium plate with collars. This plate supports the tube and therefore the pipes must not come into contact with the metal sheets. With this solution, the vibrations and thermal expansion are absorbed by the aluminium sheet. Leaks caused by friction cannot occur. The rigidity of the coil is sustained effectively.

Energy Efficiency Class

Energy efficiency class of air cooled condensers		
Class	Energy consumption	R
A	Extremely low	R>110
B	Very low	70≤R<110
C	Low	45≤R<70
D	Medium	30≤R<45
E	High	R<30

R = Condenser capacity (ΔT15K) / motor power consumption.

Test and cleaning

Coils are cleaned thoroughly in order to remove any traces of oil. Each heat exchanger undergoes a pressure and leak test with dry air at 10bar (PS= 9bar).



Sound Data

The sound pressure level is based on the calculation (according to EN 13487) of the sound pressure level on the surface of a cuboid area which is at a 10 metre distance and is parallel to the reference envelope of the sound source. (Standard sound pressure level; annex C EN 13487)

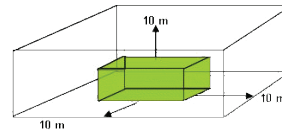

Sound pressure correction for distances other than 10 metres.

Distance (m)	2	3	4	5	7	10	15	20	30	40	50	60	80
Correction dB(A)	11	8,5	7	5	2,5	0	-3	-5,5	-9	-11	-12	-14	-16

Sound pressure level for several fans at nominal speed rating.

N° units	2	3	4	5	6	7	8	9	10
dB(A)	3	5	6	7	8	8,5	9	9,5	10

To calculate the sound pressure level, take the sound power of the individual fans according to their position, and calculate the sound propagation taking into consideration the local and ambient conditions. Speed change, start-up and control noises are not taken into account.

Fan Model	Speed rpm		Total Lw dB(A)		LW octave band spectrum dB(A)															
					63Hz		125Hz		250Hz		500Hz		1 000Hz		2 000Hz		4 000Hz		8 000Hz	
					Δ	Y	Δ	Y	Δ	Y	Δ	Y	Δ	Y	Δ	Y	Δ	Y	Δ	Y
630 S	1340	1070	90	84	-	-	68	66	76	72	78	74	83	77	81	76	78	72	70	65
630 L	900	690	77	71	-	-	62	55	69	63	72	65	75	68	72	63	64	56	58	50
630 Q	650	480	70	62	-	-	51	48	60	55	63	58	65	59	60	53	53	47	46	45
630 R	430	330	60	54	-	-	46	45	53	47	54	51	53	49	48	43	43	40	42	41
800 S	880	660	83	76	-	-	69	56	67	62	74	69	78	74	79	72	72	64	62	54
800 L	680	530	76	71	-	-	57	49	62	57	69	63	74	68	72	63	65	55	55	45
800 Q	440	340	66	60	-	-	47	42	57	48	59	54	63	56	58	51	50	43	39	34
800 R	380	240	63	52	-	-	47	42	54	44	57	47	59	48	55	42	47	34	35	26
910 T	890	700	90	83	-	-	72	70	79	73	82	76	84	79	82	76	79	73	73	66
910 S	860	660	85	79	-	-	72	70	79	73	82	76	84	79	82	76	79	73	73	66
910 L	640	440	78	70	-	-	68	62	73	68	76	70	77	70	76	70	73	67	66	60
910 Q	440	330	68	62	-	-	57	49	61	58	64	57	67	60	61	53	52	45	43	35
910 R	390	250	65	53	-	-	56	46	59	45	59	46	61	49	56	44	48	35	38	22
1000 L	680	550	86	81	-	-	58	53	68	60	70	63	73	68	75	67	71	62	62	53
1000 Q	425	325	72	65	-	-	50	45	58	50	62	54	65	58	60	50	54	42	44	30
1000 R	390	260	70	61	-	-	50	44	56	45	60	49	64	52	55	44	48	36	37	25

Guarantee

All our products are protected under warranty for 18 months from the shipping date. If a defect should occur within the warranty period, please return the equipment or part to our factory free of charge where we will repair or replace the goods, depending on what is required. Unfortunately, We cannot take responsibility for damage caused by the misuse or incorrect installation of our products. Brochure subject to technical changes without prior notice



We recommend that you use the Alfa Select Air software for a precise thermal and mechanical design.



BDM - Single Fan Row

Product description

Application

Alfa Laval Dry Coolers can be used in refrigeration, air conditioning equipment and in industrial cooling (cooling of water or other different fluids, food, power, process and general industry).

Standard design

Coil

This innovative heat exchanger gives excellent heat transfer with minimal refrigerant charge, as a result of new fin corrugation and smooth tubing developed by Alfa Laval. In the standard execution, the heat exchanger is manufactured from copper tubes and aluminum fins with spacing 2.1 mm. BDM is a Single coil model; each manifold provided with draining and venting nozzles. Each heat exchanger undergoes a pressure and leak test with dry air at 10bar (design pressure is 9bar).

Casing

Casework made with pre-painted galvanized steel sheets. A new frame design provides high rigidity for heavy applications. The new system protects the heat exchanger tubes completely during transportation and against vibration and thermal expansion while in operation. Supports manufactured in galvanized steel, with optimized length to permit uniform air suction in the coil.

Benefits

- Footprint: Optimised footprint with higher capacity.
- 630, 800, 910, 1000 mm fan
 - More performance available
 - Low power consumption fan motor
 - More noise level options
 - Flexible design
- All parts are painted in accordance with RAL 9002
 - No cut edges
 - Higher corrosion resistance, double surface treatment
 - External Corrosion Class C4
- Coil design: Increased heat transfer thanks to innovative fin corrugation
- Casing: Strong casing with new design
- High Energy Efficiency: best performance with low energy consumption

Options

- Non-standard fin spacing: for heavy dusty environment
- Coil treatment: corrosion resistance, ideal for aggressive environments
- Vibration Dampers: for reducing vibrations
- Electrical parts
 - Switch on/off: Local safety switch is wired to isolate the fan, and is also available for EMC switches.
 - Terminal Box: all fans wired for an easy electrical connection
 - Switchboard



- Cabling: ready to install
- Frequency Converter design: units can run under frequency control (when air temperature is below the design, it allows energy saving, noise reduction and longer fan motor life)
- Fan step control:
 - Energy saving
 - Cheapest method of controlling performance
- Fan speed control
 - Energy saving
 - Noise reduction when the air temperature is below the design temperature.
 - Variable and efficient speed control according to the heat rejected
 - Better performance control
- Special fans
 - 480/3ph-60Hz IP54: High adaptability for every market
 - IP 55: High protection fan for use in tropical or desert areas
 - High temperature Electric Motors: Suitable for high temperature fluids when the outlet air is too hot for the standard fan motors.

Fans

On the BDM, four different fan diameters are available: 630, 800, 910, 1000 mm. Diameter 630, 800, 910, 1000 mm with three-phase motor 400V-50Hz, for 630 (L, Q, R) also single-phase 230V-50Hz. The motors come with external rotors, protection class IP 54 according to DIN 40050, while integrated thermo contacts provide reliable protection against any instances of thermal overload. These BDM Dry Coolers are available in five fan motor noise levels: (S) standard, (L) low, (Q) quiet, (R) residential and the new (T) high performance fan. The fans are suitable for operation in air temperatures between -40°C and +40°C.

For air temperatures lower than +20°C, the full load current (FLC) can be calculated using the correction factor table. The overload protection should have a 20% margin to accommodate fan motor supplier variations.

T [°C]	20	10	0	-10	-15	-20	-25	-30
Fc	1	1,04	1,08	1,12	1,14	1,16	1,18	1,2

Model	Capacity [kW]			Pressure Drop fluid [kPa]		Airflow [m³/h]		Lp [dB(A)]*		Motor (3/400V-50Hz)		Motor (230V-50Hz)	Fans N° x D [mm]	Surface m²	Tube volume dm³	E.E.C.**		Conn. Size				
	Δ	Y	230V 50Hz	Δ	Y	Δ	Y	Δ	Y	Δ	Y					Δ	Y	Inlet	Outlet			
Ø 630																						
BDMS631A	36,0	31,3	-	20,8	16,3	17747	13697	56	50	P=2600W I _n =4,8A n=1310 min-1	P=1600W I _n =2,7A n=100 min-1	-	1X630	88,2	8	E	E	1"1/2	1"1/2			
BDMS631B	48,1	40,7	-	70,0	52,5	17182	13120	56	50				1X630	132,3	11	E	E	1"1/2	1"1/2			
BDMS631C	55,0	45,4	-	53,7	38,3	16576	12555	56	50				1X630	176,5	15	E	D	2"	2"			
BDMS631D	59,3	47,9	-	40,8	28,2	15971	12024	56	50				1X630	220,6	19	E	D	2"	2"			
BDMS632A	73,9	64,3	-	79,0	61,8	35414	27307	59	53				2X630	172,6	15	E	E	1"1/2	1"1/2			
BDMS632B	94,8	80,3	-	59,9	45,0	34227	26108	59	53				2X630	258,9	22	E	E	1"1/2	1"1/2			
BDMS632C	109,7	90,5	-	77,6	55,3	32966	24943	59	53				2X630	345,2	30	E	D	2"	2"			
BDMS632D	118,1	95,4	-	59,3	40,7	31714	23853	59	53				2X630	431,5	37	E	D	2"	2"			
BDMS633A	109,4	95,3	-	54,9	43,0	53078	40914	61	55				3X630	256,9	22	E	E	1"1/2	1"1/2			
BDMS633B	140,5	119,0	-	41,7	31,1	51269	39094	61	55				3X630	385,4	33	E	E	2"	2"			
BDMS633C	163,8	135,1	-	73,3	52,3	49351	37329	61	55				3X630	513,9	44	E	D	2"	2"			
BDMS633D	176,4	142,5	-	58,3	40,0	47454	35680	61	55				3X630	642,4	55	E	D	2"	2"			
BDMS634A	144,2	125,6	-	37,8	29,6	70742	54521	62	56				4X630	341,3	29	E	E	2"	2"			
BDMS634B	185,3	156,9	-	28,7	21,4	68310	52079	62	56				4X630	512	44	E	E	2" 1/2	2" 1/2			
BDMS634C	212,5	175,5	-	22,1	15,7	65736	49713	62	56				4X630	682,6	59	E	D	2" 1/2	2" 1/2			
BDMS634D	234,4	189,5	-	54,1	37,4	63192	47505	62	56				4X630	853,3	74	E	D	2" 1/2	2" 1/2			
BDML631A	26,8	23,99	26,8	51,19	42,04	9778	8175	45	40	P=690W I _n =1,25A n=900 min-1	P=480W I _n =0,78A n=690 min-1	P=780W I _n =3,5A n=900 min-1	1X630	88,2	8	D	C	1"1/2	1"1/2			
BDML631B	32,8	28,61	32,7	35,72	28,13	9504	7855	45	40				1X630	132,3	11	C	C	1"1/2	1"1/2			
BDML631C	36,1	30,87	35,9	25,44	19,25	9232	7552	45	40				1X630	176,5	15	C	B	2"	2"			
BDML631D	37,9	31,78	37,6	18,65	13,67	8968	7268	45	40				1X630	220,6	19	C	B	2"	2"			
BDML632A	53,5	47,86	53,5	74,16	60,88	19515	16299	48	43				2X630	172,6	15	D	C	1"1/2	1"1/2			
BDML632B	65,4	57,08	65,2	51,77	40,71	18945	15638	48	43				2X630	258,9	22	C	C	1"1/2	1"1/2			
BDML632C	72,9	62,16	72,5	83,55	63,04	18383	15014	48	43				2X630	345,2	30	C	B	2"	2"			
BDML632D	76,4	63,91	75,8	68,53	50,04	17837	14433	48	43				2X630	431,5	37	C	B	2"	2"			
BDML633A	79,9	71,49	79,9	70,15	57,59	29251	24423	50	45				3X630	256,9	22	D	C	1"1/2	1"1/2			
BDML633B	98,7	86,13	98,4	92,63	73,3	28385	23421	50	45				3X630	385,4	33	C	C	2"	2"			
BDML633C	108,8	92,71	108,1	65,92	49,73	27531	22475	50	45				3X630	513,9	44	C	B	2"	2"			
BDML633D	114,5	95,7	113,6	80,71	58,88	26705	21596	50	45				3X630	642,4	55	C	B	2"	2"			
BDML634A	106,4	95,11	106,2	68,16	55,96	38987	32547	51	46				4X630	341,3	29	D	C	2"	2"			
BDML634B	130,1	113,49	129,6	47,64	37,49	37825	31203	51	46				4X630	512	44	C	C	2" 1/2	2" 1/2			
BDML634C	145,1	123,64	144,2	76,98	58,06	36680	29935	51	46				4X630	682,6	59	C	B	2" 1/2	2" 1/2			
BDML634D	151,9	127,04	150,8	58,46	42,66	35573	28759	51	46				4X630	853,3	74	C	B	2" 1/2	2" 1/2			
BDMQ631A	21,9	19,01	21,9	36,04	28	7098	5761	38	31	P=330W I _n =0,80A n=650 min-1	P=190W I _n =0,38A n=480 min-1	P=400W I _n =1,8A n=650 min-1	1X630	88,2	8	B	A	1"1/2	1"1/2			
BDMQ631B	25,9	21,8	25,9	23,38	17,33	6868	5497	38	31				1X630	132,3	11	B	A	1"1/2	1"1/2			
BDMQ631C	27,8	22,84	27,8	16,02	11,33	6643	5253	38	31				1X630	176,5	15	B	A	2"	2"			
BDMQ632A	43,7	37,94	43,7	52,23	40,56	14161	11480	41	34				2X630	172,6	15	B	A	1"1/2	1"1/2			
BDMQ632B	51,7	43,49	51,7	33,89	25,1	13683	10935	41	34				2X630	258,9	22	B	A	1"1/2	1"1/2			
BDMQ632C	56,0	45,91	56,0	52,51	36,97	13220	10434	41	34				2X630	345,2	30	B	A	2"	2"			
BDMQ633A	65,3	56,69	65,4	49,45	38,39	21223	17198	43	36				3X630	256,9	22	B	A	1"1/2	1"1/2			
BDMQ633B	77,9	65,54	77,9	60,54	44,84	20497	16372	43	36				3X630	385,4	33	B	A	2"	2"			
BDMQ633C	84,1	68,83	84,1	69,41	48,82	19796	15615	43	36				3X630	513,9	44	B	A	2"	2"			
BDMQ634A	87,0	75,43	87,0	48,06	37,32	28285	22916	44	37				4X630	341,3	29	B	A	2"	2"			
BDMQ634B	104,0	87,48	104,0	75,34	55,79	27312	21810	44	37				4X630	512	44	B	A	2" 1/2	2" 1/2			
BDMQ634C	112,2	91,83	112,2	90,86	63,87	26371	20795	44	37				4X630	682,6	59	B	A	2" 1/2	2" 1/2			
BDMR631A	16,4	13,85	-	21,42	15,86	4662	3735	28	22				P=125W I _n =0,33A n=430 min-1	P=85W I _n =0,14A n=330 min-1	-	1X630	88,2	8	A	A	1"1/2	1"1/2
BDMR631B	18,6	15,26	-	13,05	9,24	4501	3560	28	22							1X630	132,3	11	A	A	1"1/2	1"1/2
BDMR632A	32,7	27,68	-	31,1	23,15	9300	7442	31	25							2X630	172,6	15	A	A	1"1/2	1"1/2
BDMR632B	37,7	30,88	-	80,37	56,7	8964	7080	31	25							2X630	258,9	22	A	A	1"1/2	1"1/2
BDMR633A	49,3	41,74	-	55,65	41,34	13937	11149	33	27	3X630	256,9	22				A	A	1"1/2	1"1/2			
BDMR633B	56,2	46,07	-	56,65	39,97	13427	10600	33	27	3X630	385,4	33				A	A	2"	2"			
BDMR634A	65,8	55,68	-	65,01	48,27	18574	14856	34	28	4X630	341,3	29				A	A	2"	2"			
BDMR634B	75,0	61,48	-	74,17	52,3	17889	14120	34	28	4X630	512	44				A	A	2" 1/2	2" 1/2			

Nominal capacities according to standard EN1048 (water T_{air}=25°C, T_{in}=40°C, T_{out}=35°C).
 *See the General Contents for more details.
 **Energy Efficiency Class: see "General Contents" for more details.

Model	Capacity [kW]			Pressure Drop fluid [kPa]		Airflow [m³/h]		Lp [dB(A)]*		Motor (3/400V-50Hz)		Motor (230V-50Hz)	Fans N° x D [mm]	Surface m²	Tube volume dm³	E.E.C.**		Conn. Size		
	Δ	Y	230V 50Hz	Δ	Y	Δ	Y	Δ	Y	Δ	Y					Δ	Y	Inlet	Outlet	
Ø 630 LONG																				
BDMS631AL	41,5	36,0	-	32,6	25,4	18073	14071	56	50	P=2600W I _n =4,8A n=1310 min-1	P=1600W I _n =2,7A n=1000 min-1	-	1x630	88,2	8	E	E	1"1/2	1"1/2	
BDMS631BL	52,8	44,7	-	24,3	18,2	17748	13698	56	50				1x630	132,3	11	E	D	1"1/2	1"1/2	
BDMS631CL	61,4	50,6	-	42,5	30,0	17379	13314	56	50				1x630	176,5	15	E	D	2"	2"	
BDMS631DL	66,2	53,5	-	36,7	25,2	16984	12931	56	50				1x630	220,6	19	E	D	2"	2"	
BDMS632AL	83,9	72,7	-	66,3	51,6	36111	28098	59	53				2x630	172,6	15	E	E	1"1/2	1"1/2	
BDMS632BL	106,8	90,2	-	52,8	39,4	35434	27328	59	53				2x630	258,9	22	E	D	1"1/2	1"1/2	
BDMS632CL	123,0	101,3	-	71,3	50,2	34666	26536	59	53				2x630	345,2	30	E	D	2"	2"	
BDMS632DL	132,4	106,9	-	54,6	37,5	33848	25749	59	53				2x630	431,5	37	E	D	2"	2"	
BDMS633AL	126,2	109,5	-	89,1	69,3	54148	42125	61	55				3x630	256,9	22	E	E	2"	2"	
BDMS633BL	160,7	135,6	-	67,0	49,5	53118	40957	61	55				3x630	385,4	33	E	D	2"	2"	
BDMS633CL	183,0	150,8	-	50,5	35,6	51951	39757	61	55				3x630	513,9	44	E	D	2"	2"	
BDMS633DL	197,1	159,3	-	38,7	26,6	50709	38565	61	55				3x630	642,4	55	E	D	2"1/2	2"1/2	
BDML631AL	29,1	26,1	29,2	17,4	14,4	9959	8393	45	40	P=690W I _n =1,25A n=900 min-1	P=480W I _n =0,78A n=690 min-1	P=780W I _n =3,5A n=900 min-1	1x630	88,2	8	C	C	1"1/2	1"1/2	
BDML631BL	36,2	31,6	36,2	51,6	40,8	9779	8175	45	40				1x630	132,3	11	C	B	1"1/2	1"1/2	
BDML631CL	39,6	34,0	39,5	36,4	27,8	9596	7961	45	40				1x630	176,5	15	C	B	2"	2"	
BDML631DL	41,4	35,0	41,2	26,6	19,7	9414	7753	45	40				1x630	220,6	19	C	B	2"	2"	
BDML632AL	59,6	53,3	59,7	68,0	55,6	19897	16760	48	43				2x630	172,6	15	C	C	1"1/2	1"1/2	
BDML632BL	71,9	62,8	71,8	46,2	36,2	19525	16312	48	43				2x630	258,9	22	C	B	1"1/2	1"1/2	
BDML632CL	79,2	67,9	78,9	54,3	41,4	19149	15871	48	43				2x630	345,2	30	C	B	2"	2"	
BDML632DL	82,7	69,8	82,3	39,6	29,4	18773	15445	48	43				2x630	431,5	37	C	B	2"	2"	
BDML633AL	88,6	79,2	88,7	47,7	39,4	29835	25127	50	45				3x630	256,9	22	C	C	2"	2"	
BDML633BL	108,4	94,7	108,2	78,4	62,0	29271	24448	50	45				3x630	385,4	33	C	B	2"	2"	
BDML633CL	118,5	101,6	118,1	52,0	39,7	28701	23781	50	45				3x630	513,9	44	C	B	2"	2"	
BDML633DL	124,5	105,0	123,9	71,2	52,8	28132	23136	50	45				3x630	642,4	55	C	B	2"1/2	2"1/2	
BDMQ631AL	24,3	21,1	24,3	52,5	40,8	7253	5946	38	31	P=330W I _n =0,80A n=650 min-1	P=190W I _n =0,38A n=480 min-1	P=400W I _n =1,8A n=650 min-1	1x630	88,2	8	B	A	1"1/2	1"1/2	
BDMQ631BL	28,3	24,0	28,4	33,6	25,0	7099	5761	38	31				1x630	132,3	11	B	A	1"1/2	1"1/2	
BDMQ631CL	30,3	25,1	30,3	22,7	16,3	6945	5583	38	31				1x630	176,5	15	B	A	2"	2"	
BDMQ632AL	48,6	42,1	48,6	78,2	60,8	14488	11870	41	34				2x630	172,6	15	B	A	1"1/2	1"1/2	
BDMQ632BL	56,7	47,9	56,7	50,0	37,2	14170	11490	41	34				2x630	258,9	22	B	A	1"1/2	1"1/2	
BDMQ632CL	61,0	50,4	61,0	76,1	54,4	13853	11125	41	34				2x630	345,2	30	B	A	2"	2"	
BDMQ633AL	72,7	63,0	72,6	74,9	58,2	21722	17793	43	36				3x630	256,9	22	B	A	2"	2"	
BDMQ633BL	85,4	72,1	85,4	90,1	66,9	21240	17218	43	36				3x630	385,4	33	B	A	2"	2"	
BDMQ633CL	91,1	75,3	91,2	60,9	43,5	20760	16666	43	36	3x630	513,9	44	B	A	2"	2"				
BDMR631AL	17,9	15,1	-	30,3	22,7	4765	3854	28	22	P=125W I _n =0,33A n=430 min-1	P=85W I _n =0,14A n=330 min-1	-	1x630	88,2	8	A	A	1"1/2	1"1/2	
BDMR631BL	20,1	16,6	-	18,3	13,0	4662	3735	28	22				1x630	132,3	11	A	A	1"1/2	1"1/2	
BDMR632AL	35,7	30,3	-	45,2	33,9	9518	7694	31	25				2x630	172,6	15	A	A	1"1/2	1"1/2	
BDMR632BL	40,2	33,1	-	27,2	19,4	9306	7449	31	25				2x630	258,9	22	A	A	1"1/2	1"1/2	
BDMR633AL	53,8	45,6	-	81,5	61,1	14270	11534	33	27				3x630	256,9	22	A	A	2"	2"	
BDMR633BL	60,7	50,0	-	81,9	58,3	13949	11162	33	27				3x630	385,4	33	A	A	2"	2"	

Nominal capacities according to standard EN1048 (water T_{air}=25°C, T_{in}=40°C, T_{out}=35°C).

*See the General Contents for more details.

**Energy Efficiency Class: see "General Contents" for more details.

Model	Capacity [kW]		Pressure Drop fluid [kPa]		Airflow [m³/h]		Lp [dB(A)]*		Motor (3/400V-50Hz)		Fans N° x D [mm]	Surface m²	Tube volume dm³	E.E.C.**		Conn. Size			
	Δ	Y	Δ	Y	Δ	Y	Δ	Y	Δ	Y				Inlet	Outlet				
Ø 800																			
BDMS801A	56,5	49,1	49,0	38,2	22304	17616	51	46	P=2000W I _n =4,0A n=880min-1	P=1250W I _n =2,3A n=660min-1	1X800	167,2	14	D	D	1"1/2	1"1/2		
BDMS801B	70,2	59,3	35,3	26,1	21676	16962	51	46			1X800	250,8	22	D	D	1"1/2	1"1/2		
BDMS801C	79,5	65,6	58,3	41,6	21055	16334	51	46			1X800	334,3	29	D	C	2"	2"		
BDMS801D	84,3	68,0	46,5	31,9	20452	15742	51	46			1X800	417,9	36	C	C	2"	2"		
BDMS802A	112,0	97,3	44,1	34,4	44548	35169	54	49			2X800	329,7	28	D	D	1"1/2	1"1/2		
BDMS802B	141,5	119,5	72,7	53,8	43262	33832	54	49			2X800	494,5	43	D	D	2"	2"		
BDMS802C	158,0	130,2	52,7	37,6	41993	32551	54	49			2X800	659,4	57	D	D	2"	2"		
BDMS802D	168,6	136,0	74,3	50,9	40762	31347	54	49			2X800	824,2	71	C	C	2"	2"		
BDMS803A	167,5	145,6	42,5	33,2	66791	52721	56	51			3X800	492,2	42	D	D	2"	2"		
BDMS803B	208,5	176,2	30,7	22,7	64848	50701	56	51			3X800	738,3	64	D	D	2"1/2	2"1/2		
BDMS803C	237,5	195,7	71,1	50,7	62929	48767	56	51			3X800	984,5	85	D	D	2"1/2	2"1/2		
BDMS803D	251,4	202,8	53,2	36,4	61071	46951	56	51			3X800	1230,6	106	C	C	2"1/2	2"1/2		
BDMS804A	226,8	197,0	95,7	74,6	89034	70272	57	52			4X800	654,8	57	D	D	2"1/2	2"1/2		
BDMS804B	282,0	238,1	68,9	51,0	86432	67570	57	52			4X800	982,1	85	D	D	3"	3"		
BDMS804C	314,8	259,5	50,0	35,6	83865	64983	57	52			4X800	1309,5	113	D	D	3"	3"		
BDMS804D	333,4	269,1	37,4	25,6	81380	62554	57	52			4X800	1636,9	141	C	C	3"	3"		
BDMS805A	274,8	238,9	24,2	18,9	111277	87824	58	53			5X800	817,3	71	D	D	3"	3"		
BDMS805B	342,4	289,5	17,5	13,0	108017	84438	58	53			5X800	1225,9	106	D	D	3"	3"		
BDMS805C	396,6	326,7	93,2	66,4	104800	81199	58	53			5X800	1634,6	141	D	C	4"	4"		
BDMS805D	419,8	338,5	69,7	47,7	101688	78158	58	53			5X800	2043,2	176	C	C	4"	4"		
BDML801A	49,0	43,5	84,8	69,0	17152	14190	44	40	P=1050W I _n =2,4A n=680min-1	P=770W I _n =1,5A n=530min-1	1X800	167,2	14	C	C	1"1/2	1"1/2		
BDML801B	59,8	51,6	82,2	62,5	16689	13645	44	40			1X800	250,8	22	C	B	1"1/2	1"1/2		
BDML801C	65,2	55,0	41,2	30,5	16224	13128	44	40			1X800	334,3	29	C	B	2"	2"		
BDML801D	68,5	56,7	56,3	40,4	15767	12645	44	40			1X800	417,9	36	B	B	2"	2"		
BDML802A	97,3	86,3	76,6	62,4	34261	28327	47	43			2X800	329,7	28	C	C	1"1/2	1"1/2		
BDML802B	118,2	102,0	52,8	40,5	33311	27213	47	43			2X800	494,5	43	C	B	2"	2"		
BDML802C	130,8	110,2	76,1	56,3	32359	26160	47	43			2X800	659,4	57	C	B	2"	2"		
BDML802D	136,9	113,2	85,4	61,1	31426	25179	47	43			2X800	824,2	71	B	B	2"	2"		
BDML803A	143,2	127,0	32,3	26,1	51369	42463	49	45			3X800	492,2	42	C	C	2"	2"		
BDML803B	177,9	153,3	71,9	54,7	49933	40781	49	45			3X800	738,3	64	C	B	2"1/2	2"1/2		
BDML803C	194,9	164,3	50,3	37,3	48493	39192	49	45			3X800	984,5	85	C	B	2"1/2	2"1/2		
BDML803D	204,9	169,4	82,5	59,0	47084	37712	49	45			3X800	1230,6	106	B	B	2"1/2	2"1/2		
BDML804A	193,9	172,0	72,6	59,1	68476	56599	50	46			4X800	654,8	57	C	C	2"1/2	2"1/2		
BDML804B	235,5	203,2	50,0	38,4	66554	54348	50	46			4X800	982,1	85	C	B	3"	3"		
BDML804C	258,4	217,9	35,4	26,2	64627	52223	50	46			4X800	1309,5	113	C	B	3"	3"		
BDML804D	272,9	225,6	81,0	58,0	62741	50244	50	46			4X800	1636,9	141	B	B	3"	3"		
BDML805A	235,1	208,5	18,4	14,9	85584	70735	51	47			5X800	817,3	71	C	C	3"	3"		
BDML805B	297,1	256,0	94,2	71,6	83175	67916	51	47			5X800	1225,9	106	C	B	3"	3"		
BDML805C	325,4	274,3	65,9	48,8	80760	65254	51	47			5X800	1634,6	141	C	B	4"	4"		
BDML805D	339,3	280,7	47,9	34,3	78399	62777	51	47			5X800	2043,2	176	B	B	4"	4"		
BDMQ801A	35,9	30,1	49,0	36,2	10678	8384	35	28	P=370W I _n =1,2A n=440min-1	P=200W I _n =0,5A n=340min-1	1X800	167,2	14	B	A	1"1/2	1"1/2		
BDMQ801B	41,6	33,8	43,0	29,9	10335	8013	35	28			1X800	250,8	22	A	A	1"1/2	1"1/2		
BDMQ801C	44,3	35,1	64,1	42,6	9994	7674	35	28			1X800	334,3	29	A	A	2"	2"		
BDMQ802A	71,2	59,9	44,3	32,8	21323	16731	38	31			2X800	329,7	28	B	A	1"1/2	1"1/2		
BDMQ802B	83,5	67,8	87,9	61,0	20621	15976	38	31			2X800	494,5	43	A	A	2"	2"		
BDMQ802C	88,0	69,8	58,1	38,6	19923	15287	38	31			2X800	659,4	57	A	A	2"	2"		
BDMQ803A	107,2	90,1	59,9	44,2	31968	25077	40	33			3X800	492,2	42	B	A	2"	2"		
BDMQ803B	125,0	101,5	84,9	58,9	30906	23938	40	33			3X800	738,3	64	A	A	2"1/2	2"1/2		
BDMQ803C	131,8	104,4	56,2	37,3	29852	22899	40	33			3X800	984,5	85	A	A	2"1/2	2"1/2		
BDMQ804A	142,0	119,4	42,0	31,1	42613	33424	41	34			4X800	654,8	57	B	A	2"1/2	2"1/2		
BDMQ804B	166,5	135,2	83,5	57,9	41191	31900	41	34			4X800	982,1	85	A	A	3"	3"		
BDMQ804C	175,6	139,1	55,2	36,6	39780	30510	41	34			4X800	1309,5	113	A	A	3"	3"		
BDMQ805A	179,0	150,4	78,5	57,9	53258	41770	42	35			5X800	817,3	71	B	A	3"	3"		
BDMQ805B	206,9	168,1	49,3	34,2	51476	39862	42	35			5X800	1225,9	106	A	A	3"	3"		
BDMQ805C	218,3	173,1	32,7	21,7	49708	38122	42	35			5X800	1634,6	141	A	A	4"	4"		
BDMR801A	32,2	22,9	40,5	22,1	9184	5851	31	20			P=250W I _n =0,62A n=380min-1	P=110W I _n =0,27A n=240min-1	1X800	167,2	14	A	A	1"1/2	1"1/2
BDMR801B	36,7	24,8	34,4	17,2	8840	5560	31	20					1X800	250,8	22	A	A	1"1/2	1"1/2
BDMR802A	64,0	45,5	36,6	20,0	18335	11674	34	23					2X800	329,7	28	A	A	1"1/2	1"1/2
BDMR802B	73,6	49,6	70,4	35,1	17632	11080	34	23					2X800	494,5	43	A	A	2"	2"
BDMR803A	96,3	68,4	49,5	27,0	27485	17496	36	25					3X800	492,2	42	A	A	2"	2"
BDMR803B	110,2	74,2	68,0	33,9	26423	16599	36	25	3X800	738,3			64	A	A	2"1/2	2"1/2		
BDMR804A	127,6	90,7	34,7	19,0	36636	23318	37	26	4X800	654,8			57	A	A	2"1/2	2"1/2		
BDMR804B	146,7	98,8	66,8	33,3	35214	22118	37	26	4X800	982,1			85	A	A	3"	3"		
BDMR805A	160,8	114,2	64,9	35,4	45786	29140	38	27	5X800	817,3			71	A	A	3"	3"		
BDMR805B	182,4	123,0	39,5	19,7	44005	27637	38	27	5X800	1225,9			106	A	A	3"	3"		

Nominal capacities according to standard EN1048 (water T_{air}=25°C, T_{in}=40°C, T_{out}=35°C).

*See the General Contents for more details.

**Energy Efficiency Class: see "General Contents" for more details.

Model	Capacity [kW]		Pressure Drop fluid [kPa]		Airflow [m³/h]		Lp [dB(A)]*		Motor (3/400V-50Hz)		Fans N° x D [mm]	Surface m²	Tube volume dm³	E.E.C.**		Conn. Size			
	Δ	Y	Δ	Y	Δ	Y	Δ	Y	Δ	Y				Inlet	Outlet				
Ø 910																			
BDMT901A	74,01	67,05	29,86	25,07	32371	27136	55	50	P=3600W I _n =7,2A n=890min-1	P=2500W I _n =4,3A n=700min-1	1X900	199,7	17	E	E	1"1/2	1"1/2		
BDMT901B	96,79	85,61	72,79	58,48	31787	26317	55	50			1X900	299,5	26	E	D	1"1/2	1"1/2		
BDMT901C	110,09	95,27	54,68	42,18	31070	25422	55	50			1X900	399,4	34	D	D	2"	2"		
BDMT901D	158,31	131,21	70	49,96	45309	34804	55	50			1X900	499,2	43	C	C	2"	2"		
BDMT902A	151,11	136,83	88,73	74,44	64702	54212	58	53			2X900	394,7	34	E	D	2"	2"		
BDMT902B	192,34	170,11	66,74	53,61	63493	52530	58	53			2X900	592,1	51	E	D	2"1/2	2"1/2		
BDMT902C	218,85	189,35	50,16	38,71	62017	50699	58	53			2X900	789,4	68	D	D	2"1/2	2"1/2		
BDMT902D	237,94	201,71	86,98	64,97	60396	48853	58	53			2X900	986,8	85	D	D	2"1/2	2"1/2		
BDMT903A	226,12	204,75	86,03	72,19	97032	81287	60	55			3X900	589,7	51	E	D	2"1/2	2"1/2		
BDMT903B	287,86	254,59	64,75	52	95199	78741	60	55			3X900	884,6	76	E	D	3"	3"		
BDMT903C	327,58	283,4	48,66	37,56	92962	75974	60	55			3X900	1179,5	102	D	D	3"	3"		
BDMT903D	352,04	298,65	37,17	27,79	90511	73189	60	55			3X900	1474,4	127	D	D	3"	3"		
BDMT904A	292,56	265,08	26,02	21,85	129362	108361	61	56			4X900	784,8	68	E	E	3"	3"		
BDMT904B	372,76	330,37	19,46	15,83	126904	104953	61	56			4X900	1177,2	102	E	D	4"	4"		
BDMT904C	425,45	368,68	14,82	11,52	123908	101249	61	56			4X900	1569,6	135	D	D	4"	4"		
BDMT904D	474,46	402,14	83,14	62,08	120625	97524	61	56			4X900	1961,9	169	D	D	4"	4"		
BDMS901A	62,3	53,9	68,0	52,6	22865	18106	53	48	P=1650W I _n =3,5A n=860min-1	P=1000W I _n =1,8A n=660min-1	1X900	199,7	17	D	C	1"1/2	1"1/2		
BDMS901B	76,7	64,6	48,1	35,5	22382	17610	53	48			1X900	299,5	26	C	B	1"1/2	1"1/2		
BDMS901C	86,1	71,0	78,6	55,9	21878	17110	53	48			1X900	399,4	34	C	B	2"	2"		
BDMS901D	127,3	102,2	47,2	32,3	33402	25083	53	48			1X900	499,2	43	B	A	2"	2"		
BDMS902A	123,7	107,0	62,3	48,2	45693	36173	56	51			2X900	394,7	34	D	C	2"	2"		
BDMS902B	152,5	128,6	44,1	32,7	44704	35161	56	51			2X900	592,1	51	C	B	2"1/2	2"1/2		
BDMS902C	171,4	141,2	72,3	51,4	43676	34140	56	51			2X900	789,4	68	C	B	2"1/2	2"1/2		
BDMS902D	180,7	146,3	53,5	36,9	42637	33139	56	51			2X900	986,8	85	C	B	2"1/2	2"1/2		
BDMS903A	185,2	160,2	60,5	46,8	68521	54240	58	53			3X900	589,7	51	D	C	2"1/2	2"1/2		
BDMS903B	228,3	192,5	42,8	31,7	67026	52710	58	53			3X900	884,6	76	C	B	3"	3"		
BDMS903C	257,6	212,3	98,0	69,7	65472	51170	58	53			3X900	1179,5	102	C	B	3"	3"		
BDMS903D	271,5	219,7	72,5	50,0	63904	49660	58	53			3X900	1474,4	127	C	B	3"	3"		
BDMS904A	239,9	207,8	18,3	14,2	91348	72306	59	54			4X900	784,8	68	D	C	3"	3"		
BDMS904B	308,0	259,5	95,9	70,8	89347	70260	59	54			4X900	1177,2	102	C	B	4"	4"		
BDMS904C	341,8	281,8	69,2	49,2	87268	68200	59	54			4X900	1569,6	135	C	B	4"	4"		
BDMS904D	360,5	291,8	51,2	35,3	85171	66180	59	54			4X900	1961,9	169	C	B	4"	4"		
BDML901A	51,8	41,3	49,5	33,0	17040	12201	46	39	P=900W I _n =2,2A n=640min-1	P=470W I _n =1,05A n=440min-1	1X900	199,7	17	C	B	1"1/2	1"1/2		
BDML901B	61,9	47,3	32,8	20,5	16613	11735	46	39			1X900	299,5	26	B	A	1"1/2	1"1/2		
BDML901C	67,9	50,2	51,7	30,4	16198	11315	46	39			1X900	399,4	34	B	A	2"	2"		
BDML901D	102,6	73,0	76,9	42,2	24850	16477	46	39			1X900	499,2	43	A	A	2"	2"		
BDML902A	103,0	82,1	45,4	30,3	34045	24364	49	42			2X900	394,7	34	C	B	2"	2"		
BDML902B	124,6	95,2	68,3	42,6	33176	23418	49	42			2X900	592,1	51	B	A	2"1/2	2"1/2		
BDML902C	136,1	100,5	96,7	56,7	32331	22566	49	42			2X900	789,4	68	B	A	2"1/2	2"1/2		
BDML902D	140,8	101,4	64,1	36,0	31516	21794	49	42			2X900	986,8	85	B	A	2"1/2	2"1/2		
BDML903A	154,2	122,9	44,1	29,4	51050	36525	51	44			3X900	589,7	51	C	B	2"1/2	2"1/2		
BDML903B	187,3	143,1	92,6	57,7	49739	35100	51	44			3X900	884,6	76	B	A	3"	3"		
BDML903C	203,1	150,1	64,4	37,8	48463	33816	51	44			3X900	1179,5	102	B	A	3"	3"		
BDML903D	210,4	151,6	46,3	26,0	47234	32655	51	44			3X900	1474,4	127	B	A	3"	3"		
BDML904A	208,2	165,8	98,7	65,9	68054	48687	52	45			4X900	784,8	68	C	B	3"	3"		
BDML904B	248,5	189,9	65,4	40,7	66301	46782	52	45			4X900	1177,2	102	B	A	4"	4"		
BDML904C	269,7	199,3	45,5	26,7	64595	45067	52	45			4X900	1569,6	135	B	A	4"	4"		
BDML904D	279,5	201,4	32,7	18,4	62952	43515	52	45			4X900	1961,9	169	B	A	4"	4"		
BDMQ901A	39,1	33,3	66,7	50,1	11131	8952	36	30	P=330W I _n =0,83A n=440min-1	P=190W I _n =0,38A n=340min-1	1X900	199,7	17	A	A	1"1/2	1"1/2		
BDMQ901B	45,0	37,2	57,7	41,3	10834	8627	36	30			1X900	299,5	26	A	A	1"1/2	1"1/2		
BDMQ901C	47,6	38,5	85,1	58,7	10539	8320	36	30			1X900	399,4	34	A	A	2"	2"		
BDMQ902A	77,9	66,3	61,4	45,8	22238	17877	39	33			2X900	394,7	34	A	A	2"	2"		
BDMQ902B	89,3	73,9	38,0	27,3	21632	17216	39	33			2X900	592,1	51	A	A	2"1/2	2"1/2		
BDMQ902C	94,8	76,7	78,4	54,0	21032	16592	39	33			2X900	789,4	68	A	A	2"1/2	2"1/2		
BDMQ903A	117,1	99,7	83,2	62,4	33345	26802	41	35			3X900	589,7	51	A	A	2"1/2	2"1/2		
BDMQ903B	134,2	111,0	51,6	36,9	32430	25805	41	35			3X900	884,6	76	A	A	3"	3"		
BDMQ903C	142,0	114,9	76,2	52,5	31525	24864	41	35			3X900	1179,5	102	A	A	3"	3"		
BDMQ904A	155,4	132,2	58,7	44,0	44452	35727	42	36			4X900	784,8	68	A	A	3"	3"		
BDMQ904B	178,2	147,4	36,4	26,1	43228	34393	42	36			4X900	1177,2	102	A	A	4"	4"		
BDMQ904C	189,2	153,0	75,1	51,7	42017	33136	42	36			4X900	1569,6	135	A	A	4"	4"		
BDMR901A	37,3	26,9	61,6	34,4	10412	6809	35	25			P=270W I _n =0,70A n=390min-1	P=140W I _n =0,32A n=250min-1	1X900	199,7	17	A	A	1"1/2	1"1/2
BDMR901B	42,5	29,2	52,2	27,0	10114	6526	35	25					1X900	299,5	26	A	A	1"1/2	1"1/2
BDMR902A	74,3	53,6	56,7	31,7	20801	13594	38	28					2X900	394,7	34	A	A	2"	2"
BDMR902B	84,4	58,1	34,4	17,8	20192	13020	38	28					2X900	592,1	51	A	A	2"1/2	2"1/2
BDMR903A	111,6	80,6	76,9	42,9	31189	20378	40	30	3X900	589,7			51	A	A	2"1/2	2"1/2		
BDMR903B	126,8	87,2	46,7	24,2	30269	19514	40	30	3X900	884,6			76	A	A	3"	3"		
BDMR904A	148,1	107,0	54,3	30,3	41577	27163	41	31	4X900	784,8			68	A	A	3"	3"		
BDMR904B	168,4	115,9	33,0	17,1	40347	26008	41	31	4X900	1177,2			102	A	A	4"	4"		

Nominal capacities according to standard EN1048 (water T_{air}=25°C, T_{in}=40°C, T_{out}=35°C).
 *See the General Contents for more details.
 **Energy Efficiency Class: see "General Contents" for more details.

Model	Capacity [kW]		Pressure Drop fluid [kPa]		Airflow [m³/h]		Lp [dB(A)]*		Motor (3/400V-50Hz)		Fans N° x D [mm]	Surface m²	Tube volume dm³	E.E.C.**		Conn. Size		
	Δ	Y	Δ	Y	Δ	Y	Δ	Y	Δ	Y				Inlet	Outlet			
Ø 1000																		
BDML1001A	72,2	63,2	28,6	22,6	30920	24495	54	49	P=2200W I _n =4.2A n=670min-1	P=1500W I _n =2.7A n=530min-1	1X1000	199,7	17	D	D	1"1/2	1"1/2	
BDML1001B	92,3	78,5	66,9	50,1	29511	23164	54	49			1X1000	299,5	26	C	C	1"1/2	1"1/2	
BDML1001C	102,6	85,3	48,4	34,8	28118	21918	54	49			1X1000	399,4	34	C	C	2"	2"	
BDML1001D	135,1	110,1	52,8	36,8	36229	27579	54	49			1X1000	499,2	43	C	B	2"	2"	
BDML1002A	147,3	128,8	84,8	66,9	61730	48882	57	52			2X1000	394,7	34	D	D	2"	2"	
BDML1002B	183,2	155,9	61,2	45,9	58853	46172	57	52			2X1000	592,1	51	C	C	2"1/2	2"1/2	
BDML1002C	203,7	169,3	44,3	31,8	56020	43647	57	52			2X1000	789,4	68	C	C	2"1/2	2"1/2	
BDML1002D	216,3	176,3	73,5	51,2	53371	41370	57	52			2X1000	986,8	85	C	C	2"1/2	2"1/2	
BDML1003A	220,3	192,7	82,2	64,9	92539	73268	59	54			3X1000	589,7	51	D	D	2"1/2	2"1/2	
BDML1003B	274,2	233,3	59,4	44,5	88193	69179	59	54			3X1000	884,6	76	C	C	3"	3"	
BDML1003C	304,8	253,3	43,0	30,9	83920	65375	59	54			3X1000	1179,5	102	C	C	3"	3"	
BDML1003D	320,0	261,1	31,4	21,9	79929	61948	59	54			3X1000	1474,4	127	C	C	3"	3"	
BDML1004A	285,0	249,6	24,9	19,7	123347	97654	60	55			4X1000	784,8	68	D	D	3"	3"	
BDML1004B	355,2	302,9	17,9	13,6	117532	92186	60	55			4X1000	1177,2	102	D	C	4"	4"	
BDML1004C	411,2	341,3	96,7	69,0	111820	87102	60	55			4X1000	1569,6	135	C	C	4"	4"	
BDML1004D	431,0	351,3	70,2	48,9	106488	82525	60	55			4X1000	1961,9	169	C	C	4"	4"	
BDMQ1001A	58,0	47,6	59,9	42,5	20337	14996	40	33	P=860W I _n =1.2A n=420 min-1	P=500W I _n =0.97A n=320 min-1	1X1000	199,7	17	E	D	1"1/2	1"1/2	
BDMQ1001B	68,8	53,8	39,9	25,7	19174	13827	40	33			1X1000	299,5	26	D	D	1"1/2	1"1/2	
BDMQ1001C	74,3	55,9	60,7	36,7	18131	12821	40	33			1X1000	399,4	34	D	D	2"	2"	
BDMQ1002A	115,1	94,5	54,8	39,0	40569	29893	43	36			2X1000	394,7	34	E	D	2"	2"	
BDMQ1002B	138,3	108,1	82,8	53,3	38221	27523	43	36			2X1000	592,1	51	D	D	2"1/2	2"1/2	
BDMQ1002C	147,7	110,9	55,6	33,6	36094	25496	43	36			2X1000	789,4	68	D	D	2"1/2	2"1/2	
BDMQ1003A	172,2	141,4	53,1	37,8	60801	44789	45	38			3X1000	589,7	51	E	D	2"1/2	2"1/2	
BDMQ1003B	204,5	159,9	35,5	22,8	57267	41219	45	38			3X1000	884,6	76	D	D	3"	3"	
BDMQ1003C	221,8	166,5	75,3	45,4	54056	38170	45	38			3X1000	1179,5	102	D	D	3"	3"	
BDMQ1004A	223,1	183,4	16,1	11,4	81033	59684	46	39			4X1000	784,8	68	E	D	3"	3"	
BDMQ1004B	275,7	215,4	79,1	50,9	76313	54914	46	39			4X1000	1177,2	102	D	D	4"	4"	
BDMQ1004C	294,3	221,0	53,1	32,1	72018	50844	46	39			4X1000	1569,6	135	D	D	4"	4"	
BDMR1001A	53,69	40,04	52,33	31,26	18021	11682	38	29	P=670W I _n =1.4A n=380 min-1	P=330W I _n =0.67A n=250 min-1	1X1000	199,7	17	E	E	1"1/2	1"1/2	
BDMR1001B	62,89	44,38	33,69	18,25	16984	10833	38	29			1X1000	299,5	26	D	D	1"1/2	1"1/2	
BDMR1002A	106,62	79,53	47,91	28,64	35951	23289	41	32			2X1000	394,7	34	E	E	2"	2"	
BDMR1002B	126,46	89,09	70,22	37,89	33851	21573	41	32			2X1000	592,1	51	D	D	2"1/2	2"1/2	
BDMR1003A	159,53	119,01	46,45	27,78	53881	34895	43	34			3X1000	589,7	51	E	E	2"1/2	2"1/2	
BDMR1003B	190,04	133,81	95,09	51,3	50716	32313	43	34			3X1000	884,6	76	D	D	3"	3"	
BDMR1004A	215,54	160,49	105,03	62,15	71810	46501	44	35			4X1000	784,8	68	E	E	3"	3"	
BDMR1004B	252,08	177,58	67,1	36,2	67581	43053	44	35			4X1000	1177,2	102	D	D	4"	4"	

Nominal capacities according to standard EN1048 (water T_{air}=25°C, T_{in}=40°C, T_{out}=35°C).

*See the General Contents for more details.

**Energy Efficiency Class: see "General Contents" for more details.

BDM - Single Fan Row

Drawings

Serie	Weight [kg]	Dimensions (mm)					N° feets	
		A	B	C	B	G	V	H
Ø 630								
BDM_631A	115	1475	1525	1065(V)/944(H)	-	1255(V)/1220(H)	2	4
BDM_631B	125	1475	1525	1065(V)/944(H)	-	1255(V)/1220(H)	2	4
BDM_631C	135	1475	1525	1065(V)/944(H)	-	1255(V)/1220(H)	2	4
BDM_631D	145	1475	1525	1065(V)/944(H)	-	1255(V)/1220(H)	2	4
BDM_632A	230	2565	2615	2155(V)/2084(H)	-	1255(V)/1220(H)	2	4
BDM_632B	250	2565	2615	2155(V)/2084(H)	-	1255(V)/1220(H)	2	4
BDM_632C	270	2565	2615	2155(V)/2084(H)	-	1255(V)/1220(H)	2	4
BDM_632D	290	2565	2615	2155(V)/2084(H)	-	1255(V)/1220(H)	2	4
BDM_633A	345	3655	3705	3245(V)/3174(H)	-	1255(V)/1220(H)	2	4
BDM_633B	375	3655	3705	3245(V)/3174(H)	-	1255(V)/1220(H)	2	4
BDM_633C	405	3655	3705	3245(V)/3174(H)	-	1255(V)/1220(H)	2	4
BDM_633D	435	3655	3705	3245(V)/3174(H)	-	1255(V)/1220(H)	2	4
BDM_634A	460	4745	4795	2155(V)/2084(H)	2180	1255(V)/1220(H)	3	6
BDM_634B	500	4745	4795	2155(V)/2084(H)	2180	1255(V)/1220(H)	3	6
BDM_634C	540	4745	4795	2155(V)/2084(H)	2180	1255(V)/1220(H)	3	6
BDM_634D	580	4745	4795	2155(V)/2084(H)	2180	1255(V)/1220(H)	3	6
Ø 630 LONG								
BDM_631A L	145	1785	1835	1375(V)/1304(H)	-	1255(V)/1220(H)	2	4
BDM_631B L	160	1785	1835	1375(V)/1304(H)	-	1255(V)/1220(H)	2	4
BDM_631C L	175	1785	1835	1375(V)/1304(H)	-	1255(V)/1220(H)	2	4
BDM_631D L	190	1785	1835	1375(V)/1304(H)	-	1255(V)/1220(H)	2	4
BDM_632A L	290	3185	3235	2775(V)/2104(H)	-	1255(V)/1220(H)	2	4
BDM_632B L	320	3185	3235	2775(V)/2104(H)	-	1255(V)/1220(H)	2	4
BDM_632C L	350	3185	3235	2775(V)/2104(H)	-	1255(V)/1220(H)	2	4
BDM_632D L	380	3185	3235	2775(V)/2104(H)	-	1255(V)/1220(H)	2	4
BDM_633A L	435	4585	4635	4175(V)/4104(H)	-	1255(V)/1220(H)	2	4
BDM_633B L	480	4585	4635	4175(V)/4104(H)	-	1255(V)/1220(H)	2	4
BDM_633C L	525	4585	4635	4175(V)/4104(H)	-	1255(V)/1220(H)	2	4
BDM_633D L	570	4585	4635	4175(V)/4104(H)	-	1255(V)/1220(H)	2	4

Standard Feet 500 mm.

We reserve the right to change our technical data without prior notice.

Serie	Weight [kg]	Dimensions (mm)					N° feet	
		A	B	C	D	G	V	H
Ø 800								
BDM_801A	180	2135	2185	1725(V)/1664(H)	-	1495(V)/1250(H)	2	4
BDM_801B	200	2135	2185	1725(V)/1664(H)	-	1495(V)/1250(H)	2	4
BDM_801C	220	2135	2185	1725(V)/1664(H)	-	1495(V)/1250(H)	2	4
BDM_801D	240	2135	2185	1725(V)/1664(H)	-	1495(V)/1250(H)	2	4
BDM_802A	360	3885	3935	3475(V)/3404(H)	-	1495(V)/1250(H)	2	4
BDM_802B	400	3885	3935	3475(V)/3404(H)	-	1495(V)/1250(H)	2	4
BDM_802C	440	3885	3935	3475(V)/3404(H)	-	1495(V)/1250(H)	2	4
BDM_802D	480	3885	3935	3475(V)/3404(H)	-	1495(V)/1250(H)	2	4
BDM_803A	540	5635	5685	5225(V)/5154(H)	-	1495(V)/1250(H)	2	4
BDM_803B	600	5635	5685	5225(V)/5154(H)	-	1495(V)/1250(H)	2	4
BDM_803C	660	5635	5685	5225(V)/5154(H)	-	1495(V)/1250(H)	2	4
BDM_803D	720	5635	5685	5225(V)/5154(H)	-	1495(V)/1250(H)	2	4
BDM_804A	720	7385	7435	3475(V)/3404(H)	3500	1495(V)/1250(H)	3	6
BDM_804B	800	7385	7435	3475(V)/3404(H)	3500	1495(V)/1250(H)	3	6
BDM_804C	880	7385	7435	3475(V)/3404(H)	3500	1495(V)/1250(H)	3	6
BDM_804D	960	7385	7435	3475(V)/3404(H)	3500	1495(V)/1250(H)	3	6
BDM_805A	900	9135	9185	3475(V)/3404(H)	1775(V)/1846(H)	1495(V)/1250(H)	4	8
BDM_805B	1000	9135	9185	3475(V)/3404(H)	1775(V)/1846(H)	1495(V)/1250(H)	4	8
BDM_805C	1100	9135	9185	3475(V)/3404(H)	1775(V)/1846(H)	1495(V)/1250(H)	4	8
BDM_805D	1200	9135	9185	3475(V)/3404(H)	1775(V)/1846(H)	1495(V)/1250(H)	4	8
Ø 910								
BDM_901A	215	2485	2535	2075(V)/2004(H)	-	1495(V)/1290(H)	2	4
BDM_901B	240	2485	2535	2075(V)/2004(H)	-	1495(V)/1290(H)	2	4
BDM_901C	265	2485	2535	2075(V)/2004(H)	-	1495(V)/1290(H)	2	4
BDM_901D	290	2485	2535	2075(V)/2004(H)	-	1495(V)/1290(H)	2	4
BDM_902A	430	4585	4635	4175(V)/4104(H)	-	1495(V)/1290(H)	2	4
BDM_902B	480	4585	4635	4175(V)/4104(H)	-	1495(V)/1290(H)	2	4
BDM_902C	530	4585	4635	4175(V)/4104(H)	-	1495(V)/1290(H)	2	4
BDM_902D	580	4585	4635	4175(V)/4104(H)	-	1495(V)/1290(H)	2	4
BDM_903A	645	6685	6735	6275(V)/6204(H)	-	1495(V)/1290(H)	2	4
BDM_903B	720	6685	6735	6275(V)/6204(H)	-	1495(V)/1290(H)	2	4
BDM_903C	795	6685	6735	6275(V)/6204(H)	-	1495(V)/1290(H)	2	4
BDM_903D	870	6685	6735	6275(V)/6204(H)	-	1495(V)/1290(H)	2	4
BDM_904A	860	8785	8835	4175(V)/4104(H)	4200	1495(V)/1290(H)	3	6
BDM_904B	960	8785	8835	4175(V)/4104(H)	4200	1495(V)/1290(H)	3	6
BDM_904C	1060	8785	8835	4175(V)/4104(H)	4200	1495(V)/1290(H)	3	6
BDM_904D	1160	8785	8835	4175(V)/4104(H)	4200	1495(V)/1290(H)	3	6
Ø 1000								
BDM_1001A	215	2485	2535	2075(V)/2004(H)	-	1495(V)/1290(H)	2	4
BDM_1001B	240	2485	2535	2075(V)/2004(H)	-	1495(V)/1290(H)	2	4
BDM_1001C	265	2485	2535	2075(V)/2004(H)	-	1495(V)/1290(H)	2	4
BDM_1001D	290	2485	2535	2075(V)/2004(H)	-	1495(V)/1290(H)	2	4
BDM_1002A	430	4585	4635	4175(V)/4104(H)	-	1495(V)/1290(H)	2	4
BDM_1002B	480	4585	4635	4175(V)/4104(H)	-	1495(V)/1290(H)	2	4
BDM_1002C	530	4585	4635	4175(V)/4104(H)	-	1495(V)/1290(H)	2	4
BDM_1002D	580	4585	4635	4175(V)/4104(H)	-	1495(V)/1290(H)	2	4
BDM_1003A	645	6685	6735	6275(V)/6204(H)	-	1495(V)/1290(H)	2	4
BDM_1003B	720	6685	6735	6275(V)/6204(H)	-	1495(V)/1290(H)	2	4
BDM_1003C	795	6685	6735	6275(V)/6204(H)	-	1495(V)/1290(H)	2	4
BDM_1003D	870	6685	6735	6275(V)/6204(H)	-	1495(V)/1290(H)	2	4
BDM_1004A	860	8785	8835	4175(V)/4104(H)	4200	1495(V)/1290(H)	3	6
BDM_1004B	960	8785	8835	4175(V)/4104(H)	4200	1495(V)/1290(H)	3	6
BDM_1004C	1060	8785	8835	4175(V)/4104(H)	4200	1495(V)/1290(H)	3	6
BDM_1004D	1160	8785	8835	4175(V)/4104(H)	4200	1495(V)/1290(H)	3	6

Standard Feet 500 mm.

We reserve the right to change our technical data without prior notice.

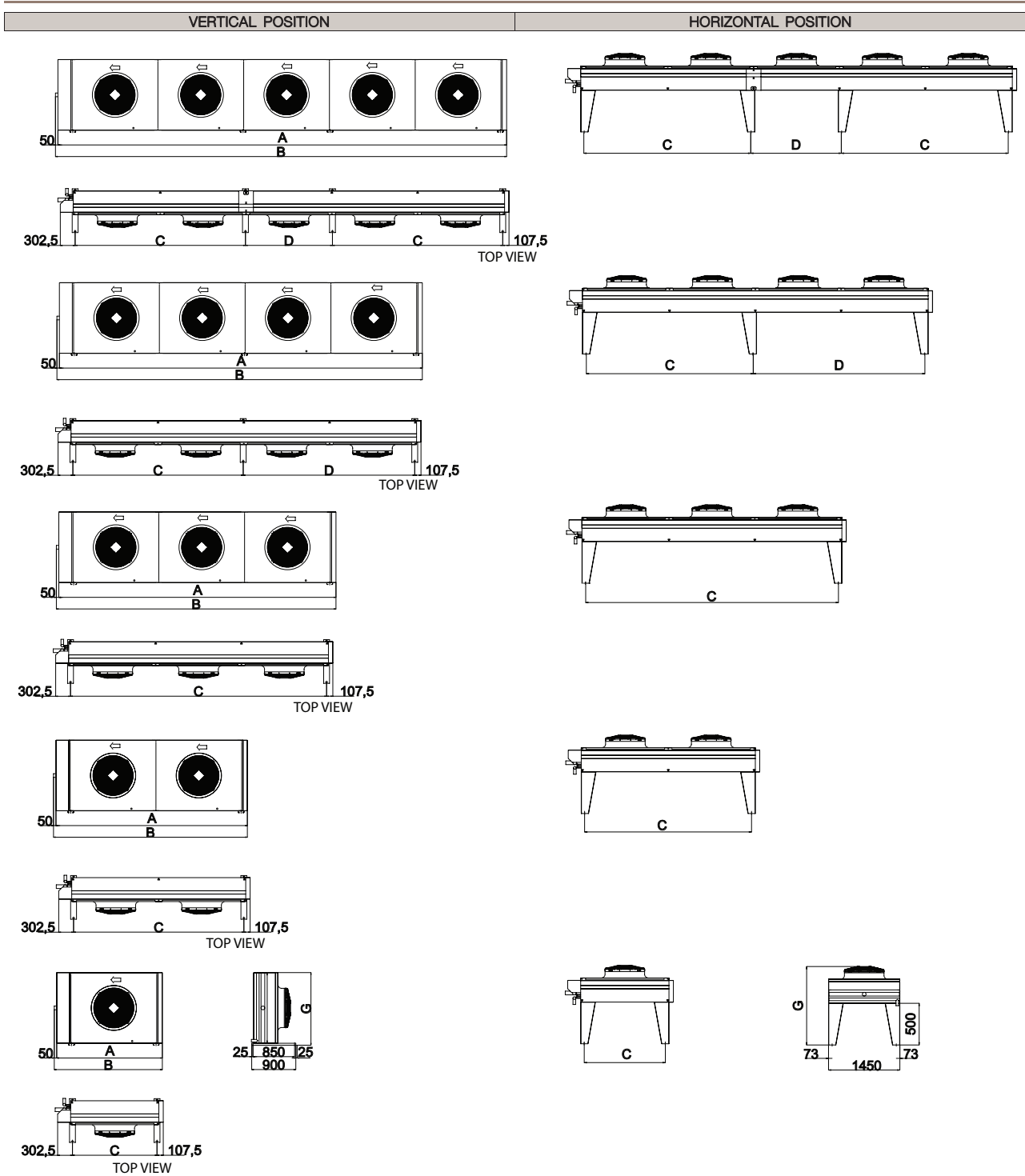

BDM - Single Fan Row

Options

Motor fans



(a) Fan motor 400 V/3ph - 60Hz, IP54: Q/R for Ø 630/800/910/1000 and also S/L for Ø 630/800/910
 (b) Fan motor 460 V/3ph - 60Hz, IP54: Q/R for Ø 630/800/910/1000 and also S/L for Ø 630/800/910
 (c) Fan motor 230V/1ph - 50/60Hz, IP54: L/Q for Ø 630

Model:
 Ø 630^(a,b,c)
 Ø 630 Long^(a,b,c)
 Ø 800 ^(a,b)
 Ø 910^(a,b)
 Ø1000 ^(a,b)

Local safety switch wired



Local safety switch and cabling for each electric fan motor. Plastic covering box, IP65, nominal current 16A – 3 phases, insulated voltage 600V. Material / Colour: Polycarbonate grey (yellow-red handle)
 Mechanical duration: 20,000 operations. Operating temperature: -10°C, + 50°C Reference and standard CE/UL/CSA. Per unit.

Model:
 All Models

Local safety switch EMC



See Electrical Data Page.

Model:
 All Models

Terminal Box

See Electrical Data Page.

Model:
 All Models

Switchboard and cabling		
	<p>Function</p> <p>Switchboard for supply and control of fan motors.</p> <p>A switchboard can supply up to 8 individual motors or 8 paired motors (i.e. max. of 16 motors).</p> <p>Switchboard and cabling are supplied as standard for vertical installation of the unit.</p> <p>If you have different needs, please specify these when placing your order.</p> <p>Operating conditions</p> <p>Type of installation: External wall mounted</p> <p>Protection degree: IP55 door closed</p> <p>Climate: Normal</p> <p>Operating temperature: $-10 \div +35^{\circ}\text{C}$ (base) $-25 \div +50^{\circ}\text{C}$ (with optional)</p> <p>Ambient relative humidity: <95%</p> <p>Altitude: <1000metres above sea level</p> <p>Electrical data</p> <p>Insulating nominal voltage: 690V</p> <p>Operating voltage: 3Ph. 400Vac</p> <p>Frequency: 50Hz</p> <p>Auxiliaries voltage: 24-230V</p> <p>Nominal current: Max 80A</p> <p>Mechanical data</p> <p>Material: Pre-painted galvanized steel</p> <p>Fixing plate: Sheet of steel (min. thickness 15/10 Sendzimir galvanized)</p> <p>Gasket: Polyurethane</p> <p>Door: opening more than 180°.</p> <p>Colour: RAL 7035</p> <p>Cable gland: metric ISO</p>	<p>Model: BDM</p> <p>All Models</p>
Switchboard Options		
	<p>R Anti-condensate resistor 230Vac (operating temperature $-25 \div + 35^{\circ}\text{C}$)</p> <p>C Cooling fan 230VAC (operating temperature $-10 \div + 50^{\circ}\text{C}$)</p> <p>F Cooling fan + anti-condensate resistor</p>	<p>Model:</p> <p>All Models</p>
Switchboard with Fan Speed control		
	<p>Switchboard and cabling, including an electronic fan speed controller (equipment that checks and regulates the speed rotation of the fan's motor, keeping the temperature for dry coolers within the range of pre-defined values). Constant control of the fan speed is achieved by variation of the electrical supply by phase-cut, as determined by the probe signal. The fan speed controller comes pre-connected to the switchboard. If you have different needs, please specify these when placing your order.</p>	<p>Model:</p> <p>All Models</p>
Switchboard with Fan Step control		
	<p>Switchboard and cabling, including an automatic on/off switch that checks and regulates the speed rotation of the fan's motor, keeping the temperature for dry coolers within the range of preset values. Control of the fan speed is achieved by variation of the electrical supply by the ON/OFF device, as determined by the probe signal. The fan step controller comes pre-connected to the switchboard. If you have different needs, please specify these when placing your order.</p>	<p>Model:</p> <p>All Models</p>
Switchboard with Frequency Converter (Inverter)		
	<p>See Electrical Data Page.</p>	<p>Model:</p> <p>All Models</p>
Coil Treatment / Material		
	<p>Thermoguard for industrial or sea coast application.</p> <p>Aluminium fins, pre-coated.</p> <p>Copper fins.</p> <p>Application Use: More information on corrosion prevention can be found in the Miscellaneous section.</p>	<p>Model:</p> <p>All Models</p>

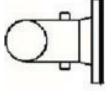
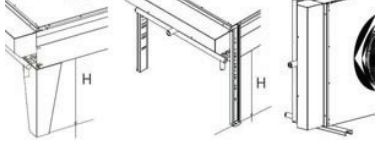
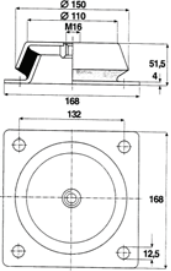
Non-standard fin spacing																					
The standard fin spacing is 2.1mm. Alternative: 2.5mm and 3.2mm						Model: All Models															
Flanges AISI																					
						Model: All Models															
Feet																					
 <p>H Horizontal Position (500 and 850mm) A Feet adjustable from 350-950cm V Vertical Position</p>						Model: All Models															
Vibration Dampers																					
						<table border="1"> <thead> <tr> <th>Type</th> <th>H mm</th> <th>A mm</th> <th>B mm</th> <th>C mm</th> <th>D mm</th> <th>Weight Kg</th> </tr> </thead> <tbody> <tr> <td>Single Row</td> <td>51.5</td> <td>132</td> <td>168</td> <td>M16</td> <td>12.5</td> <td>2.15</td> </tr> </tbody> </table> <p>Nuts and bolts are not included with these dampers.</p>		Type	H mm	A mm	B mm	C mm	D mm	Weight Kg	Single Row	51.5	132	168	M16	12.5	2.15
Type	H mm	A mm	B mm	C mm	D mm	Weight Kg															
Single Row	51.5	132	168	M16	12.5	2.15															
						Model: BDM All Models															

BDM - Single Fan Row

Electrical Data

Safety Switch

Function

Local safety switch and cabling for each electric fan motor.

General data

Power Supply:

- 400VAC, 50/60Hz
- Max fuse 16A

Number of poles: 3PCabinet Material: Plastic Case

Cabinet Colour: Grey (Yellow-Red Knob)

Protection Class: Min IP65

Ambient Temp.: min. -25°C, max. +50°C

Weight: Approx. 0.4Kg

Dimensions

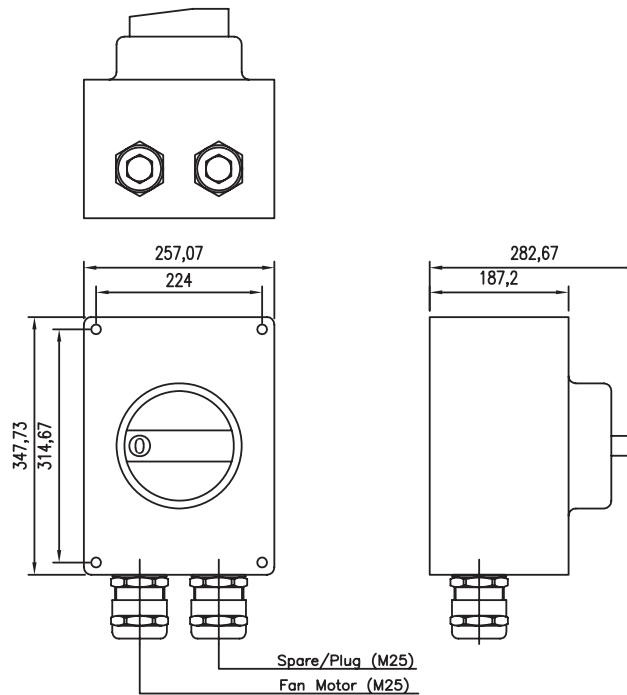

Safety Switch EMC

Function

Local safety switch and cabling for each electric fan motor.

General data

Power Supply:

- 400VAC, 50/60Hz
- Max fuse 16A

Number of poles: 3P

Cabinet Material: Plastic case with internal copper-painted

Cabinet Colour: Grey (Yellow-Red Knob)

Protection Class: Min IP65

Ambient Temp.: min. -25°C, max. +50°C

Weight: Approx. 0.4Kg

Dimensions

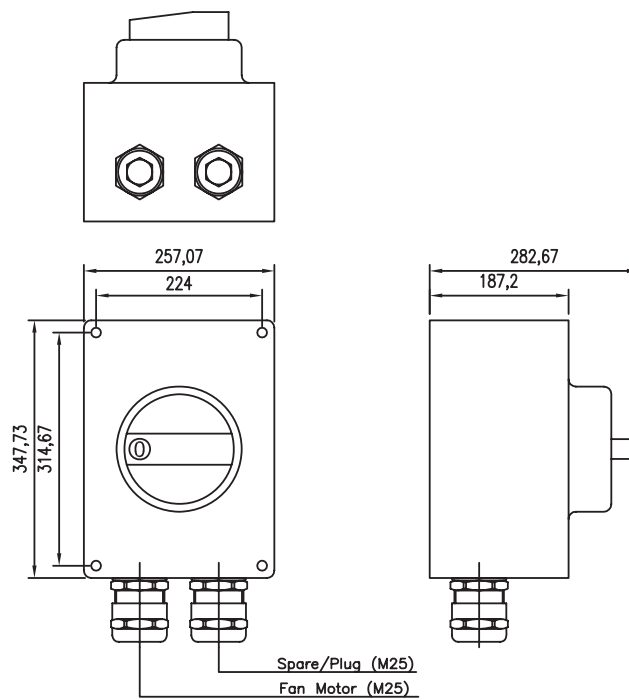

Terminal Box

Function

Connection box for electric fan motor

General data

Material: Plastic
 IP Protection Class: Min RAL 7035
 Colour: Grey RAL 7035
 Insulation Class: II
 Ambient Temp.: min. -40°C, max. +80°C
 Weight: Approx. 0.5Kg.

Dimensions

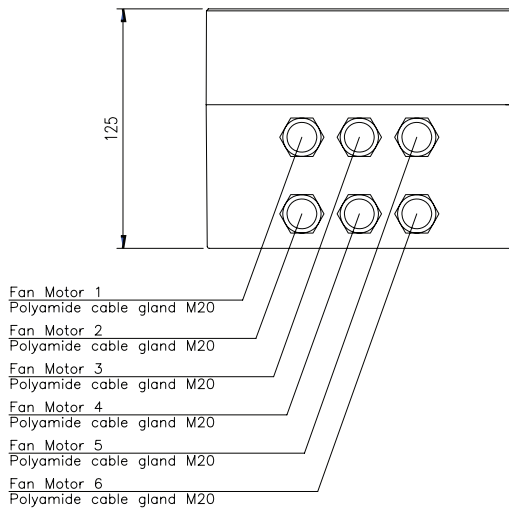
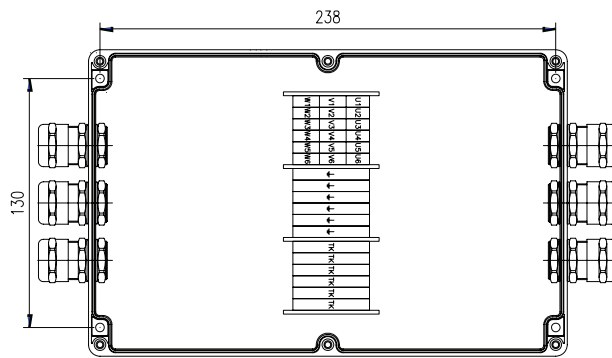

Switch Board (Control Panel)

Function

Basic Version for Horizontal Installation

General data

Cabinet Material: Sheet steel 15/10mm zinc-coated

Internal Plate: Sheet steel 20/10mm zinc-coated

Protection Class: IP 55

Cabinet Colour: RAL 7035, light grey polyester paint

Cabinet Doors: Opening angle 110°

Ambient Temp.:

- min. -10°C, max. +35°C standard
- min. -25°C, max. +35°C with electrical heater
- min. -10°C, max. +50°C with cooling fan
- min. -25°C, max. +50°C with heater and fan

Cables included: Bottom position with cable glands.

Dimensions

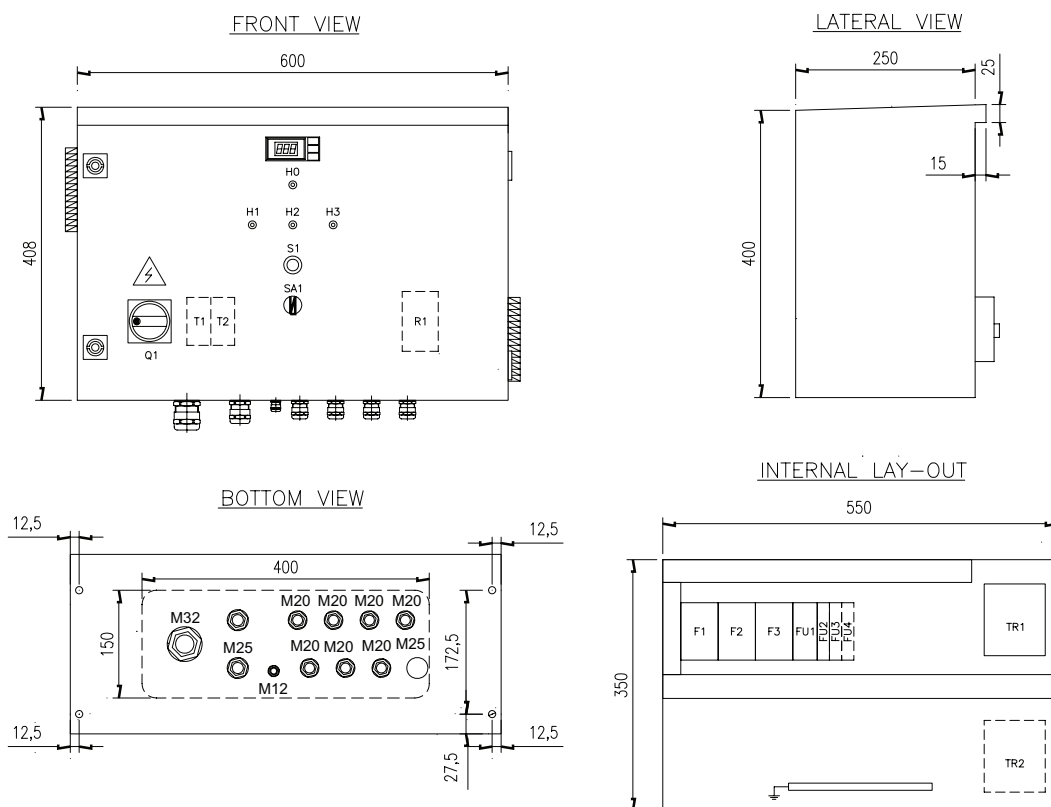

Labels list

- H0 VOLTAGE BOARD ON
- H1 FAN MOTOR 1-2 RUNNING (OPTION)
- H2 FAN MOTOR 3-4 RUNNING (OPTION)
- H3 FAN MOTOR 5-6 RUNNING (OPTION)

- Q1 MAIN SWITCH
- TC1 TEMPERATURE/PRESSURE CONTROLLER (OPTION)
- S1 RESET (OPTION)
- SA1 MAN - AUT SELECTION (OPTION)

Electric wiring diagram

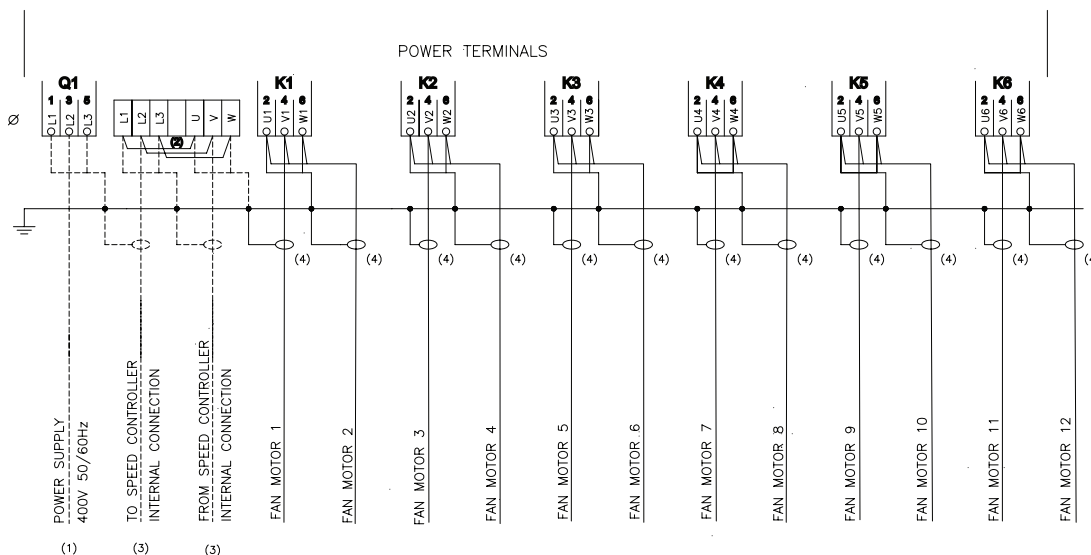

- NOTE:**
- (1) EXTERNAL SHORT CIRCUIT PROTECTION MAX FUSE
 - (2) REMOVE JUMPERS WHEN SPEED CONTROLLER IS ORDERED
 - (3) NOT MOUNTED WHEN FAN SPEED CONTROLLER IS ORDERED
 - (4) SHIELDED CABLE TO BE USED ONLY WHEN EMC CABLING OPTION IS REQUESTED
- CABLE NOT INCLUDED IN ALFA LAVAL DELIVERY
 _____ CABLE INCLUDED IN ALFA LAVAL DELIVERY

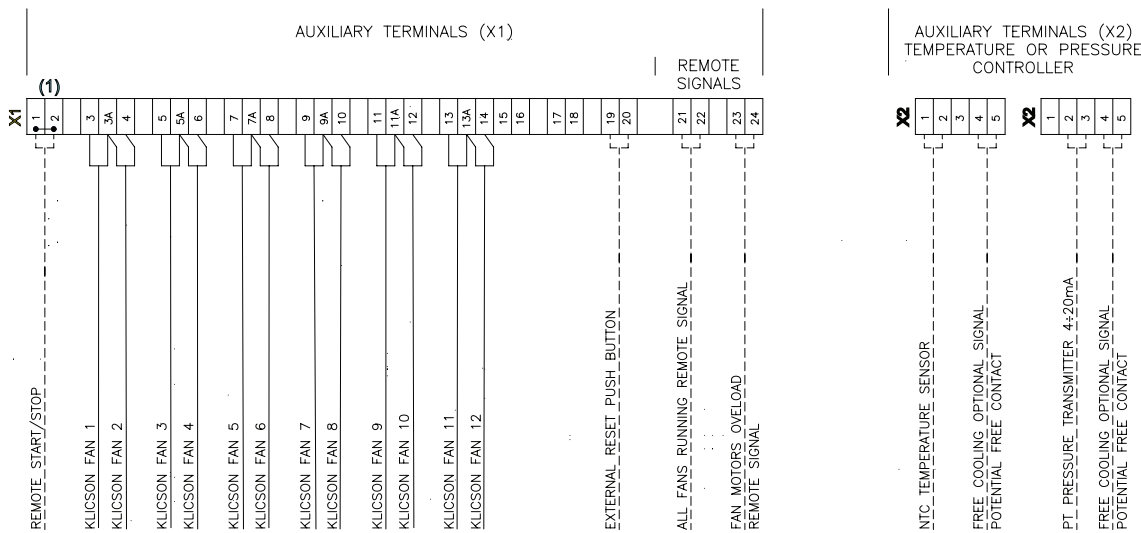

- NOTE:**
- (1) REMOVE JUMPER WHEN USED

Switch Board (Control Panel)

Function

Basic Version for Vertical Installation

General data

Cabinet Material: Sheet steel 15/10mm zinc-coated

Internal Plate: Sheet steel 20/10mm zinc-coated

Protection Class: IP 55

Cabinet Colour: RAL 7035, light grey polyester paint

Cabinet Doors: Opening angle 110°

Ambient Temp.:

- min. -10°C, max. +35°C standard
- min. -25°C, max. +35°C with electrical heater
- min. -10°C, max. +50°C with cooling fan
- min. -25°C, max. +50°C with heater and fan

Cables included: Bottom position with cable glands.

Dimensions

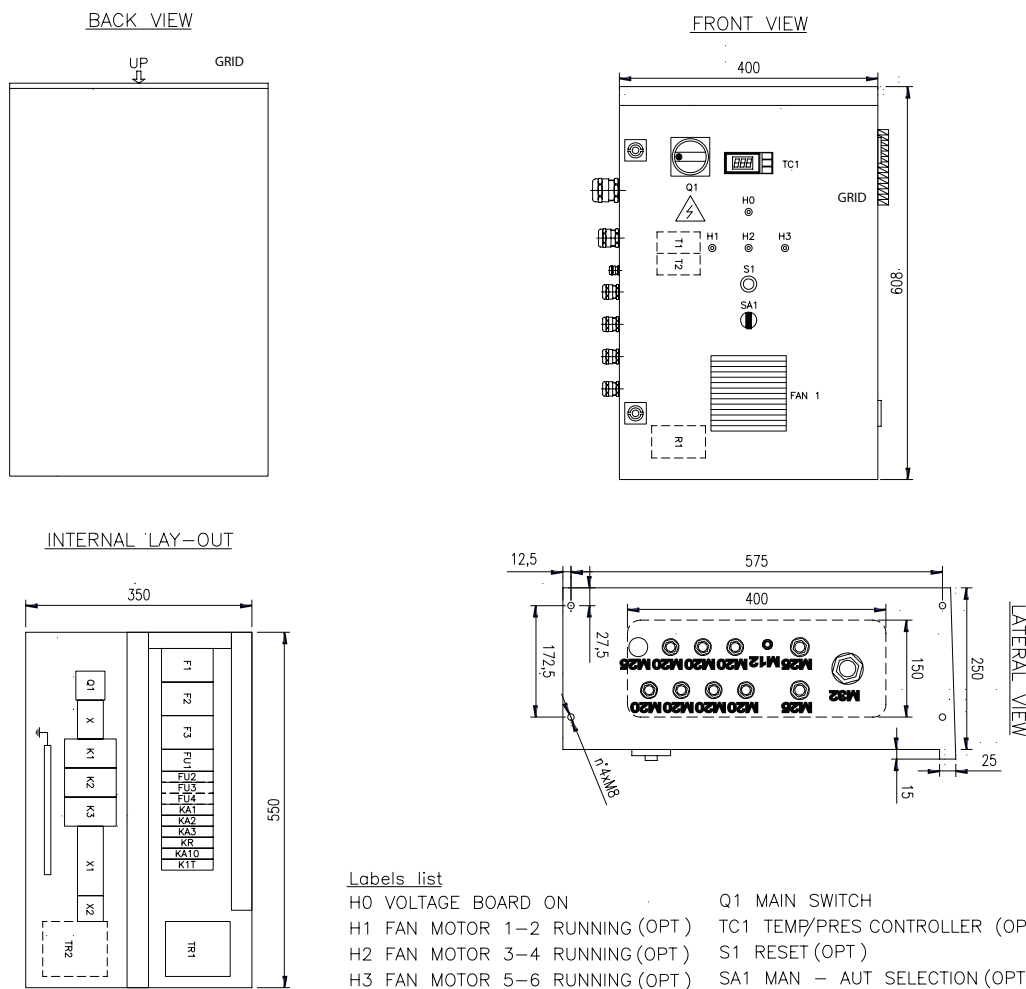

- Labels list
- | | |
|--------------------------------|--------------------------------|
| H0 VOLTAGE BOARD ON | Q1 MAIN SWITCH |
| H1 FAN MOTOR 1-2 RUNNING (OPT) | TC1 TEMP/PRES CONTROLLER (OPT) |
| H2 FAN MOTOR 3-4 RUNNING (OPT) | S1 RESET (OPT) |
| H3 FAN MOTOR 5-6 RUNNING (OPT) | SA1 MAN - AUT SELECTION (OPT) |

Electric wiring diagram

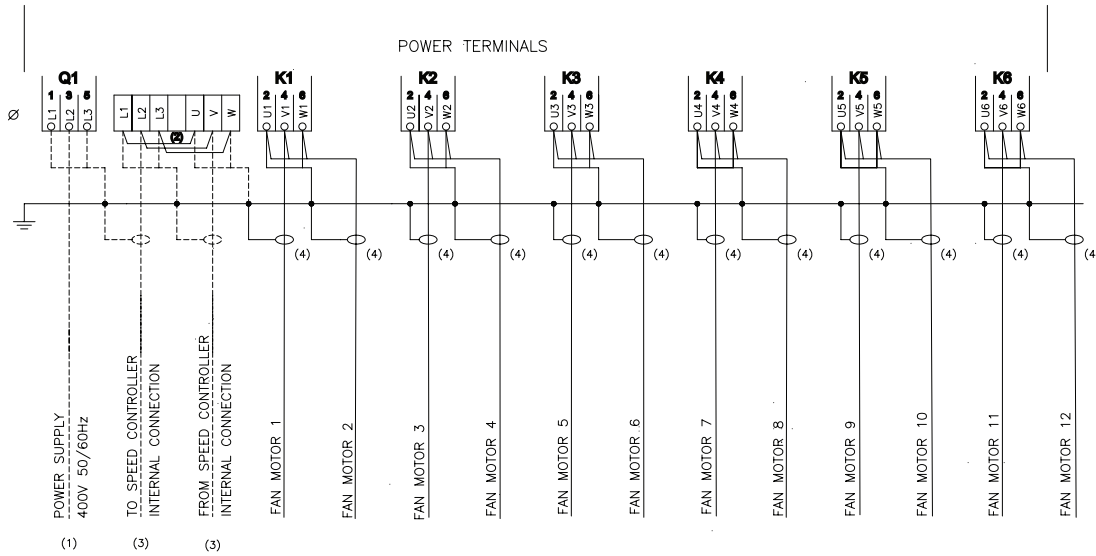

- NOTE:**
- (1) EXTERNAL SHORT CIRCUIT PROTECTION MAX FUSE
 - (2) REMOVE JUMPERS WHEN SPEED CONTROLLER IS ORDERED
 - (3) NOT MOUNTED WHEN FAN SPEED CONTROLLER IS ORDERED
 - (4) SHIELDED CABLE TO BE USED ONLY WHEN EMC CABLING OPTION IS REQUESTED
- CABLE NOT INCLUDED IN ALFA LAVAL DELIVERY
 _____ CABLE INCLUDED IN ALFA LAVAL DELIVERY

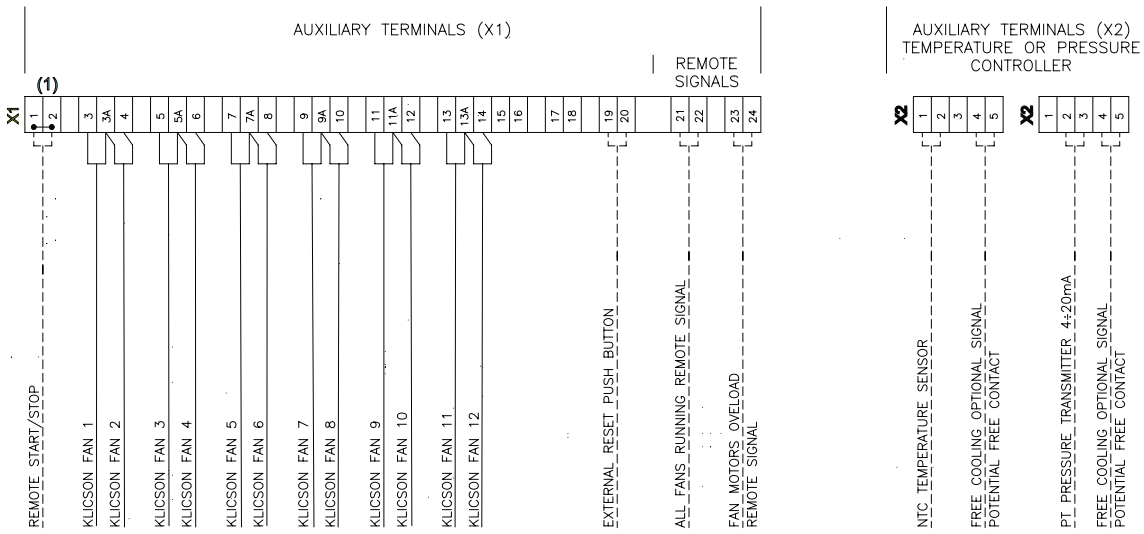

- NOTE:**
- (1) REMOVE JUMPER WHEN USED

Current Distribution

Function

Current distributors are available as optional accessories. Numerous fans can be connected. In combination with Fcontrol frequency inverters, we can deliver the current distribution with both main switch and bypass function. Features: The current distributor is equipped with plastic housing IP54 and motor protection units STDT16E with status signal contacts ZB. It is possible to lock the motor protection units with a padlock and use them as repair switches. Fans are directly connected to the motor protection units. Line protection is guaranteed through the integrated short-circuit release. Terminals for supplying the controller output are also integrated. The current distributors are suitable for external mounting (e.g. direct mounting at refrigeration units). It's easy to see the switch position of the motor protection units through the coloured, transparent plastic door.

General data

Current distributor with main switch and bypass function:

- The controller is supplied by the current distributor
- Main switch: 100% - 0 - 1
- In position 100%, the connection to the controller output is switched off. This version is for Fcontrol frequency inverters .
- Rated current: Up to 80A

Dimensions

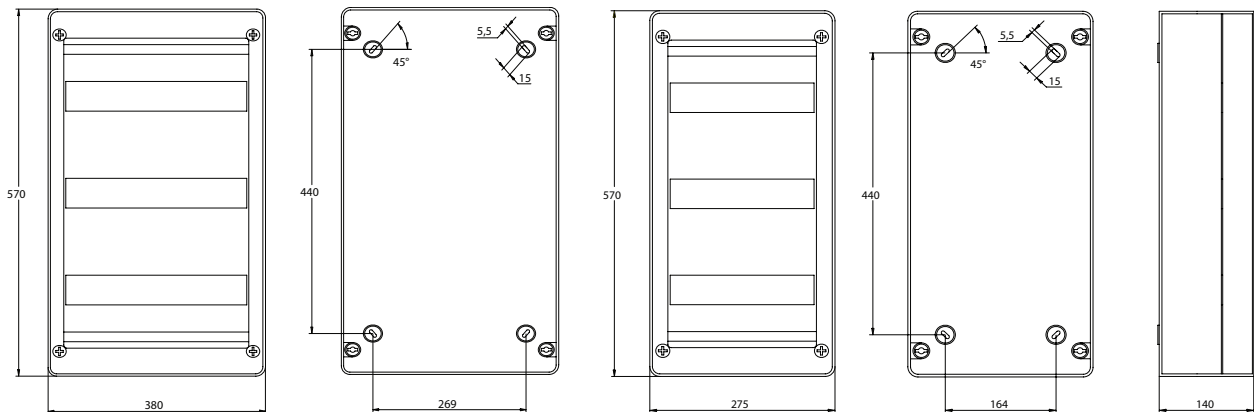

Electric wiring diagram

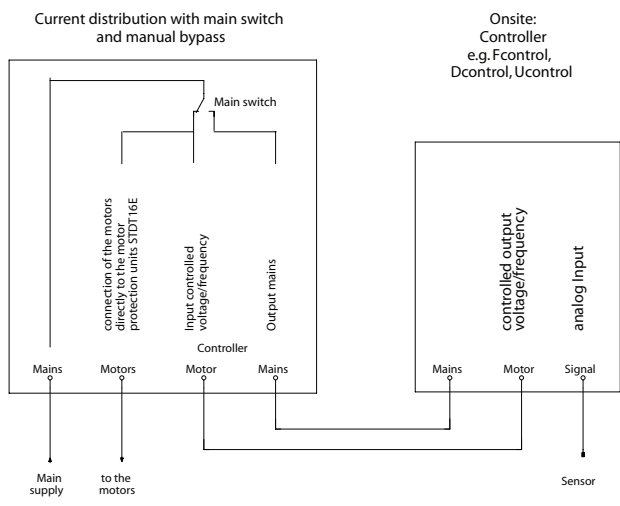

Frequency Converter (Inverter)

Function

Frequency inverter (incl. sine filter) for 3~ motors. Universal controller for refrigeration and air conditioning line input 3~ 208-480V, housing IP54, internal display.

- Speed controller with manual adjustment of output voltage at the unit or via external signal, 2-step operation;
- Temperature control for liquid coolers;
- Pressure control refrigeration (input for refrigerant) for: condensers, dual-circuit condensers;

General data

Equipment/Function

- Integrated SINEFILTER between phase to phase and phase to earth.
- Absolute parallel operation of fans, with no risk of damage to the motor. **Screened motor cables are not required.**
- Integrated process controller (PID free programmable).
- LCD multifunction display with plain language text.
- 2x Analogue Input (0-10 V, 0-20 mA, 4-20 mA, temperature sensor type TF):
 - Analogue 1 for setting of sensor signal.
 - Analogue 2 programmable function for: external set-point, difference value to sensor 1, comparison value (dual-circuit condenser), averaging, and setpoint lowering according to outdoor temperature.
- 1x output 0-10V, programmable function: Constant voltage, proportional modulation, proportional input signal, group control, controller 2.
- 2x digital inputs, programmable function: enable (on / off), external fault, limit output, input 1/2, set-point 1/2, setting internal / external, automatic control / speed manual, reverse control function ("heating" / "cooling"), reset, setting max. speed.
- 2x relay outputs, programmable function: operating indication, fault indication, external fault from digital input, limit modulation, limit input signal, limit offset (deviation actual value setpoint), group control .
- Total motor protection using thermocontact / thermistor connection.
- Interface system with RS485 Interface (MODBUS) or LON® is another alternative option.

Technical data

- Line voltage 3~ 208 BND_480V (-15% / +10%), 50/60Hz.

Rated current*/A	4	8	13	18	22	32	40
Max. line fuse/A	10	10	16	20	25	35	50
Max. heat dissipation*/W	130	210	350	440	540	950	1.100
Weight/Kg	8.8	9.0	22.8	25.4	28.1	29.5	31.8

*at line voltage 400V / 50Hz (for FXDM40A rated current - only possible for fans with $\cos \phi < 0.8$).

- Maximum output frequency 100Hz (for FXDM40, max. 60Hz).
- Clock frequency 16 kHz.
- Max. permissible ambient temperature 40°C (up to 55°C with derating).
- Voltage supply for sensors +24V ±20% (I_{max.} 120 mA).
- Permissible rel. humidity 85% with no condensation .
- Interference emission EN 61000-6-3 1 (unshielded motor cable).
- Interference immunity EN 61000-6-2.

Settings

- Quick start-up with pre-programming modes.
- Set-point 1, set-point 2, manual mode.
- Min. and max. speed, speed limitation e.g. for night operation.
- Group control (via relay or 0-10V signal output).
- Limits: Modulation, input signal, offset (deviation set to actual value).
- Set protection, save user settings.
- Readout events memory (checking the fault log).
- Masking up to 3 settable speed ranges.
- Minimum rate of air on / off.
- Edge frequency, max. frequency / voltage, start voltage.
- U/f characteristics: quadratic or linear.
- Menu language: English, German, Italian, Swedish, etc.
- Inverting: Inputs analogue and digital, analogue out, relays.

BDM - Single Fan Row

Code description

Code No.

	1	2	3	4
BDM	S	63	2	A

1) Type of noise level (number of dB(A) to reduce compared with "base" version)

	Turbo noise level	Standard noise level	Low noise level	Quiet noise level	Residential noise level
	T	S*	L*	Q*	R*
Fan diameter Ø 630mm (normal / long)	-	base	-10	-18	-29
Fan diameter Ø 800mm	-	base	-7	-16	-20
Fan diameter Ø 910 mm	base	-2	-9	-19	-20
Fan diameter Ø 1 000 mm	-	-	base	-14	-16

2) Fan diameter Ø

63	630 mm
80	800 mm
90	910 mm
100	1 000 mm

3) Number of Fans (* available in this version)

	Fan diameter Ø 630mm	Fan diameter Ø 630 mm	Fan diameter Ø 800mm	Fan diameter Ø 910 mm	Fan diameter 1000mm
1	*	*	*	*	*
2	*	*	*	*	*
3	*	*	*	*	*
4	-	*	*	*	*
5	-	-	*	-	-

4) Number of coil rows

A	2
B	3
C	4
D	5

General Alfa Select Air Legend

Description 1		Description 2	
D	D fan cabling (three phase)	AL	Aluminium fin
Y	Y fan cabling (three phase)	CU	Copper fin
D/Y	D/Y fan cabling (three phase), single speed fan motor	PR	Pre-coated fin
S	Single phase	SS	Stainless steel tube
P	Packaged on a pallet	TH	Thermoguard treatment
CR	Packaged in a crate	CF	Cataphoresis treatment
BO	Packaged in a box	SC	Sub-cooling circuit
Feet	Feet-mounted	KW	Spray water kit
SW	Safety Switch	FL	Flanges
CB	Terminal Box	FH	Fan ring heater
B	Basic Switch Board	IS	Insulated Drip Tray
BS	Basic Switch Board + Signal	RH	Reheating coil
BP	Basic Switch Board + Step Control Pressure	SR	Air socket adapter ring
PT	Basic Switch Board + Step Control Temperature	CW	Air throw fan cowling
BSP	Basic Switch Board + Step Control Pressure + Signal	ER	120° elbow reducer
BST	Basic Switch Board + Step Control Temp. + Signal	HN	Hinged fan cowling
BFP	Basic Switch Board + Speed Control Pressure		
BFT	Basic Switch Board + Speed Control Temperature		
BSFP	Basic Switch Board + Speed Control Pres. + Signal		
BSFT	Basic Switch Board + Speed Control Temp. + Signal		
BI	Basic Switch Board + Frequency Converter (Inverter)		
BBI	Basic Switch Board + Frequency Converter (Inverter) + Signal		
C	Switch Board + Cooling fan		
R	Switch Board + Resistor		
F	Switch Board + Cooling fan + Resistor		
PT	Ammonia pump top		
PB	Ammonia pump bottom		
AL	Aluminium casing		
SS	Stainless Steel casing		
AP	Pre-painted Aluminium casing		
PL	Plastic casing		
E	Electrical defrost		
LE	Low Electrical defrost		
A	Air Defrost		
HG	Hot Gas Defrost		
HG+E	Hot Gas Defrost + Electrical Defrost on drip tray		
W	Water Defrost		
W+E	Water Defrost + Electrical Defrost on drip tray		

Note: valid for the entire product range

BDD/BDD6 - Double Fan Row

Product description

Application

The Alfa Laval dry coolers can be used in refrigeration, air conditioning equipment and in Industrial Cooling (cooling of water or other different fluids), Power, Process and General Industry.

Standard design

Coil

Innovative heat exchanger gives excellent heat transfer with minimized coolant charge thanks to the new fins corrugation, developed by Alfa Laval, combined with two different tube sizes 1/2" (BDD series) and 5/8" (BDD6 series). The BDD/BDD6 has two rows of fan motors. With the standard execution, the heat exchanger is manufactured from copper tubes and aluminium fins with spacing 2.1 mm. The BDD/BDD6 series are provided with double connections giving the opportunity for two independent lines. Each manifold provided with draining and venting nozzles. Each heat exchanger undergoes a pressure and leaking test with dry air at 11 bar.

Casing

Casework made with galvanized steel sheets painted (corrosion resistance class C4). New design frame provides high rigidity also for heavy applications. New system protects perfectly the heat exchanger tubes during transportation and operation against vibration and thermal expansion. Support manufactured in galvanized steel, with optimised length to permit uniform air suction in the coil.

Benefits

- Footprint: Optimized footprint with higher capacity.
- 630, 800, 910, 1000 mm fan
 - More performance available
 - Low power consumption fan motor
 - More noise level options
 - Flexible design
- All parts are painted in accordance with RAL 9002
 - No cut edges
 - Higher corrosion resistance, double surface treatment
 - External Corrosion Class C4
- Coil design: Increased heat transfer thanks to innovative fin corrugation
- Flanges UNI EN 1092-1: simple and accurate piping connection.
- Casing: Strong casing with new design
- High Energy Efficiency: best performance with low energy consumption

Options

- Non-standard fin spacing: for heavy dusty environment
- Spray water device
 - Smaller units can be selected.



- maintains performance during outside temperature peaks.

- Coil treatment: corrosion resistance
- Vibration Dampers: for reducing vibrations
- Electrical parts
 - Switch on/off: Local safety switch is wired to isolate the fan, and is also available for EMC switches.
 - Terminal Box: all fans wired for an easy electrical connection
 - Switchboard
- Cabling: ready to install
- Frequency Converter design: units can run under frequency control (when air temperature is below the design, it allows energy saving, noise reduction and longer fan motor life)
- Fan step control:
 - Energy saving
 - Cheapest method of controlling performance

- Fan speed control
 - Energy saving
 - Noise reduction when the air temperature is below the design temperature.
 - Variable and efficient speed control according to the heat rejected
 - Better performance control
- Special fans
 - 480/3ph-60Hz IP54: High adaptability for every market
 - IP 55: High protection fan for use in tropical or desert areas
 - High temperature Electric Motors: for use when the air temperature is higher than permitted for the use of standard fans.

Fans

On the BDD and BDD6, 800, 910, 1000 mm with three-phase motor 400V-50Hz. The motors are with external rotor, protection class IP54 according to DIN 40050. AlfaBlue BDD/BDD6 Integrated thermal protection by thermo contacts provides reliable protection against thermal overload. These Dry Coolers are available in five noise levels fan motor, (S) standard, (L) low, (Q) quiet, (R) residential and the new (T) high performance fan. Dry coolers BDD/BDD6 800 mm fans are available in 4 noises level fan motor, (S), (L), (Q) (R). Dry Coolers BDD/BDD6 910 are available in 5 noises level fan motor, (T) , (S) , (L) , (Q) and (R). Dry Coolers BDD/BDD6 1000 are available in 3 noises level fan motor, (L), (Q) and (R). New bell mouths optimize the performance of the fan motors and minimize the noise level. Each fan chamber is separated by internal baffle plates which enables optimal capacity control by separate running of the fans.

The fans are suitable for operation in air temperatures between -40°C and +40°C.

For air temperatures lower than +20°C, the full load current (FLC) can be calculated using the correction factor table. The overload protection should have a 20% margin to accommodate fan motor supplier variations.

T [°C]	20	10	0	-10	-15	-20	-25	-30
Fc	1	1,04	1,08	1,12	1,14	1,16	1,18	1,2

Model	Capacity [kW]		Airflow [m³/h]		Pressure Drop fluid [kPa]		Lp [dB(A)]*		Motor (3/400V-50Hz)		Fans N° x D [mm]	Surface m²	Tube volume dm³	E.E.C.**		Conn. Size	
	Δ	Y	Δ	Y	Δ	Y	Δ	Y	Δ	Y				Δ	Y	Inlet	Outlet
Ø 800																	
BDDS 802 A	196,8	171,4	86375	67511	52	41	56	51	P=2000W I _n =4,0A n=880min-1	P=1250W I _n =2,3A n=660min-1	4x800	512,9	44	E	D	2x3"	2x3"
BDDS 802 B	251,4	212,1	82528	63667	92	68	56	51			4x800	769,3	66	D	C	2x3"	2x3"
BDDS 802 C	281,9	231,1	78902	60202	68	47	56	51			4x800	1025,7	87	D	C	2x3"	2x3"
BDDS 802 D	300,8	241,1	75556	57121	95	64	56	51			4x800	1282,2	109	D	C	2x3"	2x3"
BDDS 803 A	294,6	256,6	129469	101171	53	41	58	53			6x800	765,7	66	E	D	2x3"	2x3"
BDDS 803 B	369,6	312,4	123657	95370	38	29	58	53			6x800	1148,5	99	D	D	2x3"	2x3"
BDDS 803 C	423,8	347,7	118187	90146	94	66	58	53			6x800	1531,4	132	D	C	2x3"	2x3"
BDDS 803 D	448,2	359,3	113142	85509	66	45	58	53			6x800	1914,2	165	D	C	2x3"	2x3"
BDDS 804 A	399,1	347,4	172562	134831	119	93	59	54			8x800	1018,5	88	E	D	2x4"	2x4"
BDDS 804 B	500,5	422,3	164785	127071	87	64	59	54			8x800	1527,8	132	D	D	2x4"	2x4"
BDDS 804 C	561,3	460,2	157470	120090	64	45	59	54			8x800	2037,0	176	D	C	2x4"	2x4"
BDDS 804 D	594,1	476,5	150728	113895	48	32	59	54			8x800	2546,3	220	D	C	2x4"	2x4"
BDDS 805 A	483,0	420,8	215655	168490	30,1	24	60	55			10x800	1271,3	110	E	E	2x4"	2x4"
BDDS 805 B	606,4	512,9	205913	158773	22	16	60	55			10x800	1907,0	164	D	D	2x4"	2x4"
BDDS 805 C	707,4	580,1	196753	150033	120	84	60	55			10x800	2542,7	219	D	C	2x4"	2x4"
BDDS 805 D	748,3	599,6	188313	142282	89	60	60	55			10x800	3178,3	274	D	C	2x4"	2x4"
BDDS 806 A	587,2	511,5	258748	202148	50,9	40	61	56	12x800	1524,2	132	E	D	2x4"	2x4"		
BDDS 806 B	736,7	622,7	247041	190474	37	28	61	56	12x800	2286,2	197	D	D	2x4"	2x4"		
BDDS 806 C	827,4	679,7	236036	179977	27	19	61	56	12x800	3048,3	263	D	C	2x4"	2x4"		
BDDS 806 D	877,5	704,6	225898	170668	20	14	61	56	12x800	3810,4	328	D	C	2x4"	2x4"		
BDDL 802 A	169,9	150,5	66511	54300	40	32	49	45	P=1050W I _n =2,4A n=680min-1	P=770W I _n =1,5A n=530min-1	4x800	512,9	44	D	C	2x3"	2x3"
BDDL 802 B	212,0	182,3	63614	51149	68	52	49	45			4x800	769,3	66	C	C	2x3"	2x3"
BDDL 802 C	233,0	195,3	60848	48339	48	35	49	45			4x800	1025,7	87	C	C	2x3"	2x3"
BDDL 802 D	245,0	200,8	58274	45857	66	46	49	45			4x800	1282,2	109	C	B	2x3"	2x3"
BDDL 803 A	254,4	225,3	99697	81371	41	33	51	47			6x800	765,7	66	D	C	2x3"	2x3"
BDDL 803 B	312,3	268,5	95319	76617	29	22	51	47			6x800	1148,5	99	C	C	2x3"	2x3"
BDDL 803 C	350,3	293,5	91143	72383	66	49	51	47			6x800	1531,4	132	C	C	2x3"	2x3"
BDDL 803 D	365,3	299,4	87263	68646	46	33	51	47			6x800	1914,2	165	C	B	2x3"	2x3"
BDDL 804 A	327,6	290,4	132883	108442	12	10	52	48			8x800	1018,5	88	D	C	2x4"	2x4"
BDDL 804 B	422,2	362,7	127024	102084	64	49	52	48			8x800	1527,8	132	C	C	2x4"	2x4"
BDDL 804 C	464,1	388,9	121439	96426	45	33	52	48			8x800	2037,0	176	C	C	2x4"	2x4"
BDDL 804 D	484,4	397,2	116252	91434	33	23	52	48			8x800	2546,3	220	C	B	2x4"	2x4"
BDDL 805 A	417,3	369,7	166068	135512	23,2	18,75	53	49			10x800	1271,3	110	D	E	2x4"	2x4"
BDDL 805 B	512,8	441,1	158728	127551	16	13	53	49			10x800	1907,0	164	C	C	2x4"	2x4"
BDDL 805 C	585,1	489,7	151733	120468	85	62	53	49			10x800	2542,7	219	C	C	2x4"	2x4"
BDDL 805 D	609,7	499,5	145241	114223	62	43	53	49			10x800	3178,3	274	C	B	2x4"	2x4"
BDDL 806 A	507,2	449,2	199253	162582	39,2	31,66	54	50	12x800	1524,2	132	D	E	2x4"	2x4"		
BDDL 806 B	622,6	535,3	190432	153018	28	21	54	50	12x800	2286,2	197	C	C	2x4"	2x4"		
BDDL 806 C	685,5	574,9	182028	144511	20	14	54	50	12x800	3048,3	263	C	C	2x4"	2x4"		
BDDL 806 D	716,4	588,1	174229	137011	14	10	54	50	12x800	3810,4	328	C	B	2x4"	2x4"		
BDDQ 802 A	128,4	107,8	41159	31868	58	42	40	33	P=370W I _n =1,2A n=440min-1	P=200W I _n =0,5A n=340min-1	4x800	512,9	44	B	A	2x3"	2x3"
BDDQ 802 B	150,5	121,8	39047	29823	67	46	40	33			4x800	769,3	66	A	A	2x3"	2x3"
BDDQ 802 C	159,4	125,6	37077	28059	72	48	40	33			4x800	1025,7	87	A	A	2x3"	2x3"
BDDQ 803 A	192,9	161,9	61687	47750	74	54	42	35			6x800	765,7	66	B	A	2x3"	2x3"
BDDQ 803 B	224,2	181,7	58497	44666	49	34	42	35			6x800	1148,5	99	B	A	2x3"	2x3"
BDDQ 803 C	238,6	188,0	55525	42010	73	48	42	35			6x800	1531,4	132	A	A	2x3"	2x3"
BDDQ 804 A	255,7	214,7	82215	63631	55	40	43	36			8x800	1018,5	88	B	A	2x4"	2x4"
BDDQ 804 B	297,2	241,0	77947	59509	34	24	43	36			8x800	1527,8	132	B	A	2x4"	2x4"
BDDQ 804 C	317,8	250,3	73973	55961	74	49	43	36			8x800	2037,0	176	A	A	2x4"	2x4"
BDDQ 805 A	322,5	270,6	102743	79512	102	75	44	37			10x800	1271,3	110	B	A	2x4"	2x4"
BDDQ 805 B	374,4	303,3	97396	74352	64	44	44	37			10x800	1907,0	164	A	A	2x4"	2x4"
BDDQ 805 C	394,9	311,3	92421	69912	43	28	44	37			10x800	2542,7	219	A	A	2x4"	2x4"
BDDQ 806 A	377,1	316,7	123270	95393	23	17	45	38			12x800	1271,3	110	B	A	2x4"	2x4"
BDDQ 806 B	439,2	356,3	116845	89195	15	10	45	38			12x800	1907,0	164	B	A	2x4"	2x4"
BDDQ 806 C	475,9	375,0	110869	83863	71	46	45	38			12x800	3048,3	263	A	A	2x4"	2x4"
BDDR 802 A	115,5	82,4	35183	22093	48	26	36	25			P=250W I _n =0,62A n=380min-1	P=110W I _n =0,27A n=240min-1	4x800	512,9	44	A	A
BDDR 802 B	132,6	89,2	33164	20482	53	26	36	25	4x800	769,3			66	A	A	2x3"	2x3"
BDDR 803 A	173,5	123,7	52725	33098	61	34	38	27	6x800	765,7			66	A	A	2x3"	2x3"
BDDR 803 B	199,5	134,0	49677	30670	89	44	38	27	6x800	1148,5			99	A	A	2x3"	2x3"
BDDR 804 A	230,0	164,1	70266	44103	45	25	39	28	8x800	1018,5			88	A	A	2x4"	2x4"
BDDR 804 B	265,7	178,5	66190	40857	87	43	39	28	8x800	1527,8			132	A	A	2x4"	2x4"
BDDR 805 A	289,9	206,7	87807	55107	84	46	40	29	10x800	1271,3			110	A	A	2x4"	2x4"
BDDR 805 B	330,1	222,0	82702	51045	52	26	40	29	10x800	1907,0			164	A	A	2x4"	2x4"
BDDR 806 A	339,3	242,5	105347	66112	19	11	41	30	12x800	1271,3			110	A	A	2x4"	2x4"
BDDR 806 B	398,1	267,4	99215	61232	86	43	41	30	12x800	1907,0			164	A	A	2x4"	2x4"

Nominal capacities according to standard EN1048 (water Tair=25°C, Tin=40°C, Tout=35°C).

*See the General Contents for more details.

**Energy Efficiency Class: see "General Contents" for more details.

Model	Capacity [kW]		Airflow [m³/h]		Pressure Drop fluid [kPa]		Lp [dB(A)]*		Motor (3/400V-50Hz)		Fans N° x D [mm]	Surface m²	Tube volume dm³	E.E.C.**		Conn. Size			
	Δ	Y	Δ	Y	Δ	Y	Δ	Y	Δ	Y				Δ	Y	Inlet	Outlet		
Ø 910																			
BDDT 902 A	258,4	233,4	127089	104682	33,94	28,34	62	57	P=3600W I _n =7,2A n=890min-1	P=2500W, I _n =4,3A n=700min-1	4 x 900	614	52,9	E	E	2x3"	2x3"		
BDDT 902 B	340,4	300,1	122421	99251	83,3	67,1	62	57			4 x 900	921	79,4	E	D	2x3"	2x3"		
BDDT 902 C	388,7	334,0	117301	93969	65,1	50,1	62	57			4 x 900	1228	105,8	E	D	2x3"	2x3"		
BDDT 902 D	416,6	350,1	112224	89107	47,2	34,7	62	57			4 x 900	1535	132,3	D	D	2x3"	2x3"		
BDDT 903 A	375,06	339,37	190549	156917	13,87	11,69	64	59			6 x 900	917,4	79,1	E	E	2x4"	2x4"		
BDDT 903 B	509,3	448,9	183482	148714	80,7	65,0	64	59			6 x 900	1376,1	118,6	E	D	2x4"	2x4"		
BDDT 903 C	581,2	499,1	175746	140749	61,5	46,9	64	59			6 x 900	1834,8	158,1	E	D	2x4"	2x4"		
BDDT 903 D	623,0	523,8	168088	133430	46,3	34,4	64	59			6 x 900	2293,5	197,6	D	D	2x4"	2x4"		
BDDT 904 A	514,49	464,7	254009	209151	32,34	27,01	65	60			8 x 900	1220,8	105,2	E	E	2x4"	2x4"		
BDDT 904 B	659,4	581,1	244541	198176	24,4	19,5	65	60			8 x 900	1831,1	157,8	E	D	2x4"	2x4"		
BDDT 904 C	754,0	648,1	234189	187529	18,7	14,3	65	60			8 x 900	2441,5	210,3	E	D	2x4"	2x4"		
BDDT 904 D	810,6	681,7	223952	177752	14,3	10,5	65	60			8 x 900	3051,9	262,9	E	D	2x4"	2x4"		
BDDT 905 A	653,94	590,46	317468	261385	61,52	51,34	66	61			10 x 900	1524,2	131,3	E	E	2x4"	2x4"		
BDDT 905 B	837,4	737,7	305600	247638	46,4	37,1	66	61			10 x 900	2286,2	197	E	D	2x4"	2x4"		
BDDT 905 C	956,5	821,6	292632	234309	35,4	27,0	66	61			10 x 900	3048,3	262,6	E	D	2x4"	2x4"		
BDDT 905 D	1027,7	863,1	279815	222073	27,2	19,8	66	61	10 x 900	3810,4	328,2	D	D	2x4"	2x4"				
BDDS 902 A	213,8	185,9	89290	70202	24,3	19,0	58	53	P=1650W I _n =3,5A n=860min-1	P=1000W I _n =1,8A n=660min-1	4 x 900	614	52,9	D	C	2x3"	2x3"		
BDDS 902 B	274,0	231,4	86131	67097	57,0	42,2	58	53			4 x 900	921	79,4	C	C	2x3"	2x3"		
BDDS 902 C	306,0	252,2	82981	64128	42,7	30,2	58	53			4 x 900	1228	105,8	C	B	2x3"	2x3"		
BDDS 902 D	326,6	263,6	79949	61367	69,8	47,8	58	53			4 x 900	1535	132,3	C	B	2x3"	2x3"		
BDDS 903 A	329,0	285,9	133872	105241	76,5	59,6	60	55			6 x 900	917,4	79,1	D	C	2x4"	2x4"		
BDDS 903 B	410,0	346,3	129101	100555	55,3	41,0	60	55			6 x 900	1376,1	118,6	C	C	2x4"	2x4"		
BDDS 903 C	457,9	377,3	124348	96077	40,5	28,6	60	55			6 x 900	1834,8	158,1	C	C	2x4"	2x4"		
BDDS 903 D	490,7	395,8	119776	91918	92,6	63,4	60	55			6 x 900	2293,5	197,6	C	B	2x4"	2x4"		
BDDS 904 A	425,9	370,4	178455	140279	23,1	18,1	61	56			8 x 900	1220,8	105,2	D	C	2x4"	2x4"		
BDDS 904 B	531,4	449,8	172071	134011	16,7	12,5	61	56			8 x 900	1831,1	157,8	D	C	2x4"	2x4"		
BDDS 904 C	617,0	508,3	165714	128026	89,8	63,9	61	56			8 x 900	2441,5	210,3	C	B	2x4"	2x4"		
BDDS 904 D	651,2	525,6	159603	122469	66,7	45,7	61	56			8 x 900	3051,9	262,9	C	B	2x4"	2x4"		
BDDS 905 A	541,0	470,2	223037	175317	44,0	34,3	62	57			10 x 900	1524,2	131,3	D	C	2x4"	2x4"		
BDDS 905 B	674,8	570,3	215040	167468	31,9	23,6	62	57			10 x 900	2286,2	197	D	C	2x4"	2x4"		
BDDS 905 C	754,1	622,0	207080	159975	23,3	16,5	62	57			10 x 900	3048,3	262,6	C	C	2x4"	2x4"		
BDDS 905 D	797,3	644,7	199429	153020	17,2	11,8	62	57	10 x 900	3810,4	328,2	C	B	2x4"	2x4"				
BDDL 902 A	184,3	147,4	66252,0	46731	54,9	37,2	51	44	P=900W I _n =2,2A n=640min-1	P=470W I _n =1,05A n=440min-1	4 x 900	614	52,9	C	B	2x3"	2x3"		
BDDL 902 B	223,1	170,4	63696,0	44207	39,6	24,6	51	44			4 x 900	921	79,4	C	B	2x3"	2x3"		
BDDL 902 C	246,2	181,2	61293,0	42028	62,8	36,6	51	44			4 x 900	1228	105,8	B	B	2x3"	2x3"		
BDDL 902 D	255,3	182,8	59058,0	40125	45,2	25,1	51	44			4 x 900	1535	132,3	B	B	2x3"	2x3"		
BDDL 903 A	276,0	220,8	99326,0	70043	56,1	38,0	53	46			6 x 900	917,4	79,1	C	B	2x4"	2x4"		
BDDL 903 B	333,9	255,1	95469,0	66240	38,4	23,8	53	46			6 x 900	1376,1	118,6	C	B	2x4"	2x4"		
BDDL 903 C	370,0	272,2	91846,0	62961	87,3	50,8	53	46			6 x 900	1834,8	158,1	B	B	2x4"	2x4"		
BDDL 903 D	383,4	274,3	88479,0	60099	60,0	33,3	53	46			6 x 900	2293,5	197,6	B	B	2x4"	2x4"		
BDDL 904 A	357,6	286,3	132400,0	93354	17,0	11,5	54	47			8 x 900	1220,8	105,2	C	B	2x4"	2x4"		
BDDL 904 B	450,4	343,7	127243,0	88274	85,9	53,2	54	47			8 x 900	1831,1	157,8	C	B	2x4"	2x4"		
BDDL 904 C	490,9	361,3	122400,0	83893	60,0	35,0	54	47			8 x 900	2441,5	210,3	B	B	2x4"	2x4"		
BDDL 904 D	509,2	364,5	117901,0	80073	43,2	24,0	54	47			8 x 900	3051,9	262,9	B	B	2x4"	2x4"		
BDDL 905 A	454,1	363,5	165473,0	116665	32,3	21,9	55	48			10 x 900	1524,2	131,3	C	B	2x4"	2x4"		
BDDL 905 B	550,0	420,3	159016,0	110307	22,2	13,7	55	48			10 x 900	2286,2	197	C	B	2x4"	2x4"		
BDDL 905 C	600,9	443,4	152953,0	104826	15,5	9,1	55	48			10 x 900	3048,3	262,6	B	B	2x4"	2x4"		
BDDL 905 D	639,9	457,5	147322,0	100046	80,4	44,6	55	48	10 x 900	3810,4	328,2	B	B	2x4"	2x4"				
BDDQ 902 A	141,7	120,6	43194	34357	81,0	60,8	41	35	P=330W I _n =0,83A n=440min-1	P=185W I _n =0,38A n=330min-1	4 x 900	614	52,9	A	A	2x3"	2x3"		
BDDQ 902 B	163,8	135,0	41374	32490	50,9	36,2	41	35			4 x 900	921	79,4	A	A	2x3"	2x3"		
BDDQ 902 C	173,6	139,4	39651	30819	66,3	45,1	41	35			4 x 900	1228	105,8	A	A	2x3"	2x3"		
BDDQ 903 A	209,4	178,3	64753	51496	34,6	26,0	43	37			6 x 900	917,4	79,1	A	A	2x4"	2x4"		
BDDQ 903 B	246,1	202,8	62008	48683	69,0	49,0	43	37			6 x 900	1376,1	118,6	A	A	2x4"	2x4"		
BDDQ 903 C	259,2	208,3	59409	46165	46,6	31,7	43	37			6 x 900	1834,8	158,1	A	A	2x4"	2x4"		
BDDQ 904 A	282,5	240,4	86313	68635	77,4	58,1	44	38			8 x 900	1220,8	105,2	A	A	2x4"	2x4"		
BDDQ 904 B	326,6	269,2	82642	64875	48,7	34,6	44	38			8 x 900	1831,1	157,8	A	A	2x4"	2x4"		
BDDQ 904 C	344,1	276,6	79168	61512	32,1	21,9	44	38			8 x 900	2441,5	210,3	A	A	2x4"	2x4"		
BDDQ 905 A	344,8	293,7	107873	85774	20,0	15,0	45	39			10 x 900	1524,2	131,3	A	A	2x4"	2x4"		
BDDQ 905 B	410,8	338,4	103276	81066	90,6	64,4	45	39			10 x 900	2286,2	197	A	A	2x4"	2x4"		
BDDQ 905 C	432,4	347,3	98926	76858	59,7	40,6	45	39			10 x 900	3048,3	262,6	A	A	2x4"	2x4"		
BDDR 902 A	135,1	97,9	40313	25977	74,4	41,9	40	30			P=270W I _n =0,70A n=390min-1	P=140W I _n =0,32A n=250min-1	4 x 900	614	52,9	A	A	2x3"	2x3"
BDDR 902 B	154,8	106,3	38514	24430	46,1	23,8	40	30					4 x 900	921	79,4	A	A	2x3"	2x3"
BDDR 903 A	199,6	144,9	60432	38932	31,8	18,0	42	32					6 x 900	917,4	79,1	A	A	2x4"	2x4"
BDDR 903 B	232,6	159,6	57719	36602	62,4	32,2	42	32	6 x 900	1376,1			118,6	A	A	2x4"	2x4"		
BDDR 904 A	269,3	195,2	80552	51887	71,1	40,1	43	33	8 x 900	1220,8			105,2	A	A	2x4"	2x4"		
BDDR 904 B	308,7	212,0	76924	48774	44,0	22,7	43	33	8 x 900	1831,1			157,8	A	A	2x4"	2x4"		
BDDR 905 A	328,8	239,0	100671	64842	18,3	10,5	44	34	10 x 900	1524,2			131,3	A	A	2x4"	2x4"		
BDDR 905 B	388,3	266,4	96128	60946	82,0	42,2	44	34	10 x 900	2286,2	197	A	A	2x4"	2x4"				

Nominal capacities according to standard EN1048 (water T_{air}=25°C, T_{in}=40°C, T_{out}=35°C).
 *See the General Contents for more details.
 **Energy Efficiency Class: see "General Contents" for more details.

Model	Capacity [kW]		Airflow [m³/h]		Pressure Drop fluid [kPa]		Lp [dB(A)]*		Motor (3/400V-50Hz)		Fans N° x D [mm]	Surface m²	Tube volume dm³	E.E.C.**		Conn. Size			
	Δ	Y	Δ	Y	Δ	Y	Δ	Y	Δ	Y				Δ	Y	Inlet	Outlet		
Ø 1000																			
BDDL1002A	247,99	217,49	117369	92038	31,56	25,01	59	54	P=2200W I _n =4.2A n=670min-1	P=1500W I _n =2.7A n=530min-1	4x1000	614	52,9	D	D	2x3"	2x3"		
BDDL1002B	282,98	230,24	90525	66620	60,43	41,84	59	54			4x1000	921	79,4	D	D	2x3"	2x3"		
BDDL1002C	310,38	245,39	84645	61893	43,71	28,79	59	54			4x1000	1228	105,8	D	D	2x3"	2x3"		
BDDL1002D	325,23	251,31	79511	57952	69,22	43,94	59	54			4x1000	1535	132,3	D	D	2x3"	2x3"		
BDDL1003A	360,41	316,29	175877	137896	13,01	10,32	61	56			6x1000	917,4	79,1	D	D	2x4"	2x4"		
BDDL1003B	423,3	344,42	135600	99775	58,56	40,55	61	56			6x1000	1376,1	118,6	D	D	2x4"	2x4"		
BDDL1003C	464,08	366,93	126749	92668	41,29	27,19	61	56			6x1000	1834,8	158,1	D	D	2x4"	2x4"		
BDDL1003D	481,15	372,32	119028	86750	29,57	18,81	61	56			6x1000	2293,5	197,6	D	D	2x4"	2x4"		
BDDL1004A	493,6	432,9	234384	183754	30,05	23,82	62	57			8x1000	1220,8	105,2	D	D	2x4"	2x4"		
BDDL1004B	548,3	447,23	180675	132929	17,63	12,35	62	57			8x1000	1831,1	157,8	D	D	2x4"	2x4"		
BDDL1004C	602,85	477,65	168851	123442	12,55	8,3	62	57			8x1000	2441,5	210,3	D	D	2x4"	2x4"		
BDDL1004D	647,8	500,62	158544	115546	66,03	41,93	62	57			8x1000	3051,9	262,9	D	D	2x4"	2x4"		
BDDL1005B	696,42	566,98	225749	166083	33,74	23,38	63	58			10x1000	2286,2	197	D	D	2x4"	2x4"		
BDDL1005C	764,34	604,69	210953	154216	23,87	15,7	63	58			10x1000	3048,3	262,6	D	D	2x4"	2x4"		
BDDL1005D	792,98	614,27	198060	144342	17,07	10,88	63	58			10x1000	3810,4	328,2	D	D	2x4"	2x4"		
BDDQ 1002A	200,43	163,53	76192	54791	63,72	44,49	45	38	P=860W I _n =2A n=420 min-1	P=500W I _n =9.7A n=310 min-1	4x1000	614	52,9	C	B	2x3"	2x3"		
BDDQ 1002B	237,52	183,97	69672	48916	44,23	28,01	45	38			4x1000	921	79,4	B	B	2x3"	2x3"		
BDDQ 1002C	252,54	189,64	63336	44375	65,71	39,65	45	38			4x1000	1228	105,8	B	D	2x3"	2x3"		
BDDQ 1003A	300,1	244,8	114156	82053	64,98	45,35	47	40			6x1000	917,4	79,1	C	B	2x4"	2x4"		
BDDQ 1003B	355,22	275,14	104311	73220	42,84	27,14	47	40			6x1000	1376,1	118,6	B	B	2x4"	2x4"		
BDDQ 1003C	373,34	280,81	94766	66403	28,04	16,96	47	40			6x1000	1834,8	158,1	B	E	2x4"	2x4"		
BDDQ 1004A	388,57	317,35	152120	109315	19,67	13,75	48	41			8x1000	1220,8	105,2	C	B	2x4"	2x4"		
BDDQ 1004B	479,06	370,62	138949	97523	95,88	60,51	48	41			8x1000	1831,1	157,8	B	B	2x4"	2x4"		
BDDQ 1004C	502,69	377,61	126195	88430	62,62	37,81	48	41			8x1000	2441,5	210,3	B	E	2x4"	2x4"		
BDDQ 1005A	493,41	402,67	190084	136577	37,37	26,1	49	42			10x1000	1524,2	131,3	C	B	2x4"	2x4"		
BDDQ 1005B	584,59	453,24	173587	121827	24,69	15,69	49	42			10x1000	2286,2	197	B	B	2x4"	2x4"		
BDDQ 1005C	614,96	463,09	157623	110457	16,17	9,8	49	42			10x1000	3048,3	262,6	B	E	2x4"	2x4"		
BDDR 1002A	186,3	139,2	67468	42964	56,01	33,65	43	34			P=670W I _n =1.4A n=380 min-1	P=330W I _n =0.67A n=250 min-1	4x1000	614	52,9	B	B	2x3"	2x3"
BDDR 1002B	219,9	154,9	61296	38563	86,23	46,14	43	34					4x1000	921	79,4	B	A	2x3"	2x3"
BDDR 1003A	279,0	208,5	101081	64352	57,12	34,31	45	36					6x1000	917,4	79,1	B	B	2x4"	2x4"
BDDR 1003B	324,7	229,2	91759	57722	36,51	19,71	45	36	6x1000	1376,1			118,6	B	A	2x4"	2x4"		
BDDR 1004A	361,4	270,7	134692	85738	17,31	10,45	46	37	8x1000	1220,8			105,2	B	B	2x4"	2x4"		
BDDR 1004B	437,9	308,6	122221	76881	82,25	44	46	37	8x1000	1831,1			157,8	B	A	2x4"	2x4"		
BDDR 1005A	458,8	343,2	168304	107125	32,86	19,78	47	38	10x1000	1524,2			131,3	B	B	2x4"	2x4"		
BDDR 1005B	534,4	377,8	152683	96039	21,05	11,38	47	38	10x1000	2286,2			197	B	A	2x4"	2x4"		

Nominal capacities according to standard EN1048 (water T_{air}=25°C, T_{in}=40°C, T_{out}=35°C).

*See the General Contents for more details.

**Energy Efficiency Class: see "General Contents" for more details.

Model	Capacity [kW]		Airflow [m³/h]		Pressure Drop fluid [kPa]		Lp [dB(A)]*		Motor (3/400V-50Hz)		Fans N° x D [mm]	Surface m²	Tube volume dm³	E.E.C.**		Conn. Size			
	Δ	Y	Δ	Y	Δ	Y	Δ	Y	Δ	Y				Δ	Y	Inlet	Outlet		
Ø 800																			
BDD6S 802 A	185.4	159.2	85251	66370	54.3	41.5	56	51	P=2000W In=4.0A n=880min-1	P=1250W In=2.3A n=660min-1	4x800	479.6	77	E	D	2xDN80	2xDN80		
BDD6S 802 B	235.3	196.5	80929	62122	63.6	46.5	56	51			4x800	719.3	116	E	D	2xDN80	2xDN80		
BDD6S 802 C	264.1	215.0	76940	58382	44.7	31.3	56	51			4x800	959.0	153	D	D	2xDN80	2xDN80		
BDD6S 802 D	280.3	223.3	73324	55123	36.3	24.4	56	51			4x800	1198.9	192	D	D	2xDN80	2xDN80		
BDD6S 803 A	274.1	235.5	127770	99447	34.7	26.5	58	53			6x800	715.9	116	E	D	2xDN80	2xDN80		
BDD6S 803 B	351.8	293.8	121245	93039	61.3	44.8	58	53			6x800	1073.8	174	E	D	2xDN80	2xDN80		
BDD6S 803 C	395.3	321.7	115228	87407	45.4	31.7	58	53			6x800	1431.9	232	D	D	2xDN80	2xDN80		
BDD6S 803 D	418.9	333.6	109781	82502	33.6	22.6	58	53			6x800	1789.8	291	D	D	2xDN80	2xDN80		
BDD6S 804 A	372.6	320.0	170288	132524	78.4	59.9	59	54			8x800	952.3	155	E	D	2xDN100	2xDN100		
BDD6S 804 B	468.4	391.2	161559	123956	60.2	44.0	59	54			8x800	1428.5	232	E	D	2xDN100	2xDN100		
BDD6S 804 C	526.4	428.5	153515	116430	45.7	31.9	59	54			8x800	1904.6	310	D	D	2xDN100	2xDN100		
BDD6S 804 D	565.3	449.4	146237	109881	75.4	50.3	59	54			8x800	2380.8	387	D	D	2xDN100	2xDN100		
BDD6S 805 B	577.9	483.0	201873	154873	35.1	25.7	60	55			10x800	1783.0	289	E	D	2xDN100	2xDN100		
BDD6S 805 C	664.8	539.9	191801	145454	85.5	58.7	60	55			10x800	2377.4	386	D	D	2xDN100	2xDN100		
BDD6S 805 D	703.9	559.7	182693	137260	60.8	40.6	60	55			10x800	2971.7	483	D	D	2xDN100	2xDN100		
BDD6S 806 B	701.4	585.8	242186	185789	59.0	43.2	61	56			12x800	2137.6	347	E	D	2xDN100	2xDN100		
BDD6S 806 C	788.0	641.0	230088	174477	43.7	30.3	61	56			12x800	2850.2	463	D	D	2xDN100	2xDN100		
BDD6S 806 D	835.1	665.1	219149	164639	32.3	21.8	61	56			12x800	3562.7	578	D	D	2xDN100	2xDN100		
BDD6L 802 A	160.3	140.4	65670	53359	73.1	57.9	49	45	P=1050W In=2.4A n=680min-1	P=770W In=1.5A n=530min-1	4x800	479.6	77	D	C	2xDN80	2xDN80		
BDD6L 802 B	197.1	167.9	62398	49894	46.8	35.2	49	45			4x800	719.3	116	C	C	2xDN80	2xDN80		
BDD6L 802 C	220.4	183.3	59340	46872	75.0	54.6	49	45			4x800	959.0	153	C	C	2xDN80	2xDN80		
BDD6L 802 D	230.8	188.1	56551	44251	59.9	41.7	49	45			4x800	1198.9	192	C	C	2xDN80	2xDN80		
BDD6L 803 A	239.1	209.4	98425	79951	63.5	50.3	51	47			6x800	715.9	116	D	C	2xDN80	2xDN80		
BDD6L 803 B	294.8	251.1	93483	74724	45.1	33.9	51	47			6x800	1073.8	174	C	C	2xDN80	2xDN80		
BDD6L 803 C	329.2	273.7	88870	70173	63.7	46.2	51	47			6x800	1431.9	232	C	C	2xDN80	2xDN80		
BDD6L 803 D	344.0	280.4	84668	66231	44.3	30.9	51	47			6x800	1789.8	291	C	C	2xDN80	2xDN80		
BDD6L 804 A	318.0	278.5	131180	106542	59.3	46.9	52	48			8x800	952.3	155	D	C	2xDN100	2xDN100		
BDD6L 804 B	392.5	334.2	124567	99554	44.3	33.3	52	48			8x800	1428.5	232	C	C	2xDN100	2xDN100		
BDD6L 804 C	439.0	365.1	118399	93474	71.2	51.7	52	48			8x800	1904.6	310	C	C	2xDN100	2xDN100		
BDD6L 804 D	459.1	374.1	112784	88210	52.2	36.4	52	48			8x800	2380.8	387	C	C	2xDN100	2xDN100		
BDD6L 805 B	484.7	412.9	155651	124384	25.9	19.5	53	49			10x800	1783.0	289	C	C	2xDN100	2xDN100		
BDD6L 805 C	547.3	454.9	147928	116775	60.4	43.7	53	49			10x800	2377.4	386	C	C	2xDN100	2xDN100		
BDD6L 805 D	571.9	466.0	140900	110189	42.1	29.4	53	49			10x800	2971.7	483	C	C	2xDN100	2xDN100		
BDD6L 806 B	587.9	500.6	186735	149214	43.5	32.7	54	50			12x800	2137.6	347	C	C	2xDN100	2xDN100		
BDD6L 806 C	649.4	540.0	177457	140075	31.1	22.4	54	50			12x800	2850.2	463	C	C	2xDN100	2xDN100		
BDD6L 806 D	690.3	562.2	169015	132168	70.1	48.8	54	50			12x800	3562.7	578	C	C	2xDN100	2xDN100		
BDD6Q 802 A	116.8	97.3	40541	31248	41.8	30.5	40	33	P=370W In=1.2A n=440min-1	P=200W In=0.5A n=340min-1	4x800	479.6	77	B	A	2xDN80	2xDN80		
BDD6Q 802 B	139.4	112.4	38175	29029	64.3	43.8	40	33			4x800	719.3	116	B	A	2xDN80	2xDN80		
BDD6Q 802 C	147.9	116.4	36023	27154	37.4	24.5	40	33			4x800	959.0	153	B	A	2xDN80	2xDN80		
BDD6Q 803 A	174.3	145.3	60753	46815	36.4	26.5	42	35			6x800	715.9	116	B	A	2xDN80	2xDN80		
BDD6Q 803 B	207.6	167.3	57181	43470	43.6	29.7	42	35			6x800	1073.8	174	B	A	2xDN80	2xDN80		
BDD6Q 803 C	222.0	174.6	53937	40649	47.9	31.4	42	35			6x800	1431.9	232	B	A	2xDN80	2xDN80		
BDD6Q 804 A	235.5	196.2	80965	62381	81.3	59.2	43	36			8x800	952.3	155	B	A	2xDN100	2xDN100		
BDD6Q 804 B	277.2	223.4	76187	57911	53.1	36.2	43	36			8x800	1428.5	232	B	A	2xDN100	2xDN100		
BDD6Q 804 C	296.8	233.4	71851	54144	70.0	45.8	43	36			8x800	1904.6	310	B	A	2xDN100	2xDN100		
BDD6Q 805 A	293.0	244.1	101177	77947	63.6	46.3	44	37			10x800	1188.7	194	B	A	2xDN100	2xDN100		
BDD6Q 805 B	345.3	278.1	95193	72352	43.8	29.5	44	37			10x800	1783.0	289	B	A	2xDN100	2xDN100		
BDD6Q 805 C	370.5	291.4	89764	67638	65.8	43.1	44	37			10x800	2377.4	386	B	A	2xDN100	2xDN100		
BDD6Q 806 A	347.6	289.8	121388	93513	35.0	25.6	45	38			12x800	1188.7	194	B	A	2xDN100	2xDN100		
BDD6Q 806 B	417.1	336.0	114198	86793	72.8	49.5	45	38			12x800	1783.0	289	B	A	2xDN100	2xDN100		
BDD6Q 806 C	443.1	348.6	107678	81133	49.8	32.6	45	38			12x800	2850.2	463	B	A	2xDN100	2xDN100		
BDD6R 802 A	105.9	74.9	34583	21604	71.0	38.4	36	25			P=250W In=0.62A n=380min-1	P=110W In=0.27 An=240min-1	4x800	479.6	77	B	A	2xDN80	2xDN80
BDD6R 802 B	122.4	82.2	32353	19862	50.8	25.2	36	25					4x800	719.3	116	A	A	2xDN80	2xDN80
BDD6R 803 A	158.1	111.8	51818	32360	60.1	32.5	38	27					6x800	715.9	116	B	A	2xDN80	2xDN80
BDD6R 803 B	183.6	123.2	48454	29736	59.6	29.6	38	27	6x800	1073.8			174	A	A	2xDN80	2xDN80		
BDD6R 804 A	207.6	147.1	69053	43116	27.9	15.2	39	28	8x800	952.3			155	B	A	2xDN100	2xDN100		
BDD6R 804 B	243.5	163.4	64555	39610	41.9	20.8	39	28	8x800	1428.5			232	A	A	2xDN100	2xDN100		
BDD6R 805 A	262.5	185.6	86288	53872	52.7	28.5	40	29	10x800	1188.7			194	B	A	2xDN100	2xDN100		
BDD6R 805 B	303.3	203.6	80656	49484	34.6	17.2	40	29	10x800	1783.0			289	A	A	2xDN100	2xDN100		
BDD6R 806 A	311.2	220.5	103523	64627	28.8	15.7	41	30	12x800	1188.7			194	B	A	2xDN100	2xDN100		
BDD6R 806 B	366.3	245.6	96757	59358	57.4	28.5	41	30	12x800	1783.0			289	A	A	2xDN100	2xDN100		

Nominal capacities according to standard EN1048 (water Tair=25°C, Tin=40°C, Tout=35°C). *See the General Contents for more details. **Energy Efficiency Class: see "General Contents" for more details.

Model	Capacity [kW]		Airflow [m³/h]		Pressure Drop fluid [kPa]		Lp [dB(A)]*		Motor (3/400V-50Hz)		Fans N° x D [mm]	Surface m²	Tube volume dm³	E.E.C.**		Conn. Size			
	Δ	Y	Δ	Y	Δ	Y	Δ	Y	Δ	Y				Δ	Y	Inlet	Outlet		
Ø 910																			
BDD6T 902 A	249.2	222.2	125834	103133	55.5	45.3	62	57	P=3600W In=7.2A n=890min-1	P=2500W In=4.3A n=700min-1	4 x 900	574.1	93	E	E	2xDN80	2xDN80		
BDD6T 902 B	323.8	281.5	120228	96928	77.1	60.2	62	57			4 x 900	861.1	140	E	E	2xDN80	2xDN80		
BDD6T 902 C	369.4	314.1	114352	91110	63.9	47.9	62	57			4 x 900	1148.2	186	E	D	2xDN80	2xDN80		
BDD6T 902 D	395.3	329.9	108733	85905	46.2	33.4	62	57			4 x 900	1435.2	233	E	D	2xDN80	2xDN80		
BDD6T 903 A	375.6	334.8	188648	154576	71.9	58.7	64	59			6 x 900	857.8	139	E	E	2xDN100	2xDN100		
BDD6T 903 B	481.3	418.5	180167	145210	57.1	44.6	64	59			6 x 900	1286.7	209	E	E	2xDN100	2xDN100		
BDD6T 903 C	548.9	466.8	171297	136445	44.6	33.4	64	59			6 x 900	1715.5	278	E	D	2xDN100	2xDN100		
BDD6T 903 D	596.6	497.6	162830	128614	75.2	54.4	64	59			6 x 900	2144.4	348	E	D	2xDN100	2xDN100		
BDD6T 904 A	496.2	442.5	251461	206018	52.9	43.2	65	60			8 x 900	1141.4	185	E	E	2xDN100	2xDN100		
BDD6T 904 B	635.4	552.6	240104	193491	39.9	31.2	65	60			8 x 900	1712.1	278	E	E	2xDN100	2xDN100		
BDD6T 904 C	724.6	616.4	228240	181779	30.4	22.8	65	60			8 x 900	2282.8	370	E	D	2xDN100	2xDN100		
BDD6T 904 D	794.1	662.3	216925	171322	72.5	52.5	65	60			8 x 900	2853.5	463	E	D	2xDN100	2xDN100		
BDD6T 905 A	590.1	526.8	314300	257500	12.90	10.6	66	61			10 x 900	1425.1	231	E	E	2xDN100	2xDN100		
BDD6T 905 B	806.0	700.6	300041	241772	75.4	58.9	66	61			10 x 900	2137.6	347	E	E	2xDN100	2xDN100		
BDD6T 905 C	918.1	780.5	285183	227112	57.3	43.0	66	61			10 x 900	2850.2	462	E	D	2xDN100	2xDN100		
BDD6T 905 D	983.3	819.8	271021	214030	43.6	31.3	66	61			10 x 900	3562.7	578	E	D	2xDN100	2xDN100		
BDD6S 902 A	202.6	174.1	88388	69302	38.5	29.4	58	53	P=1650W In=3.5A n=860min-1	P=1000W In=1.8A n=660min-1	4 x 900	574.1	93	D	D	2xDN80	2xDN80		
BDD6S 902 B	257.4	215.4	84761	65792	51.8	37.7	58	53			4 x 900	861.1	140	D	C	2xDN80	2xDN80		
BDD6S 902 C	288.6	236.1	81216	62510	41.2	28.8	58	53			4 x 900	1148.2	186	D	C	2xDN80	2xDN80		
BDD6S 902 D	307.9	247.3	77870	59520	51.0	34.6	58	53			4 x 900	1435.2	233	C	C	2xDN80	2xDN80		
BDD6S 903 A	305.3	262.3	132510	103881	49.9	38.1	60	55			6 x 900	857.8	139	D	D	2xDN100	2xDN100		
BDD6S 903 B	382.5	320.6	127034	98586	38.0	28.0	60	55			6 x 900	1286.7	209	D	C	2xDN100	2xDN100		
BDD6S 903 C	435.6	356.0	121686	93640	64.4	44.5	60	55			6 x 900	1715.5	278	D	C	2xDN100	2xDN100		
BDD6S 903 D	460.6	369.8	116644	89139	47.5	32.2	60	55			6 x 900	2144.4	348	C	C	2xDN100	2xDN100		
BDD6S 904 A	403.6	346.8	176632	138460	36.7	28.1	61	56			8 x 900	1141.4	185	D	D	2xDN100	2xDN100		
BDD6S 904 B	505.3	423.6	169305	131379	26.6	19.6	61	56			8 x 900	1712.1	278	D	C	2xDN100	2xDN100		
BDD6S 904 C	580.4	474.3	162155	124769	65.0	45.0	61	56			8 x 900	2282.8	370	D	C	2xDN100	2xDN100		
BDD6S 904 D	613.2	492.3	155417	118757	45.8	31.1	61	56			8 x 900	2853.5	463	C	C	2xDN100	2xDN100		
BDD6S 905 A	520.0	447.6	226800	178000	71.4	54.7	62	57			10 x 900	1425.1	231	E	E	2xDN100	2xDN100		
BDD6S 905 B	641.0	536.5	211577	164172	50.7	36.9	62	57			10 x 900	2137.6	347	D	C	2xDN100	2xDN100		
BDD6S 905 C	717.6	587.2	202624	155898	37.0	25.8	62	57			10 x 900	2850.2	462	D	C	2xDN100	2xDN100		
BDD6S 905 D	759.8	610.5	194190	148375	27.5	18.7	62	57			10 x 900	3562.7	578	C	C	2xDN100	2xDN100		
BDD6L 902 A	170.6	134.5	65502	45964	55.4	36.4	51	44	P=900W In=2.2A n=640min-1	P=470W In=1.05A n=440min-1	4 x 900	574.1	93	C	B	2xDN80	2xDN80		
BDD6L 902 B	209.9	159.0	62638	43228	61.7	38.0	51	44			4 x 900	861.1	140	C	B	2xDN80	2xDN80		
BDD6L 902 C	230.1	168.6	59985	40902	41.1	23.9	51	44			4 x 900	1148.2	186	C	B	2xDN80	2xDN80		
BDD6L 902 D	242.7	173.0	57553	38897	77.4	42.7	51	44			4 x 900	1435.2	233	C	B	2xDN80	2xDN80		
BDD6L 903 A	253.0	199.5	98195	68887	35.8	23.5	53	46			6 x 900	857.8	139	C	B	2xDN100	2xDN100		
BDD6L 903 B	314.2	237.7	93874	64766	59.9	36.6	53	46			6 x 900	1286.7	209	C	B	2xDN100	2xDN100		
BDD6L 903 C	344.6	252.6	89875	61267	42.0	24.4	53	46			6 x 900	1715.5	278	C	B	2xDN100	2xDN100		
BDD6L 903 D	362.4	258.4	86214	58253	57.7	31.8	53	46			6 x 900	2144.4	348	C	B	2xDN100	2xDN100		
BDD6L 904 A	334.4	263.9	130886	91809	26.3	17.3	54	47			8 x 900	1141.4	185	C	B	2xDN100	2xDN100		
BDD6L 904 B	418.5	316.6	125109	86305	59.0	36.0	54	47			8 x 900	1712.1	278	C	B	2xDN100	2xDN100		
BDD6L 904 C	459.2	336.5	119766	81632	42.4	24.7	54	47			8 x 900	2282.8	370	C	B	2xDN100	2xDN100		
BDD6L 904 D	483.6	344.7	114874	77608	68.2	37.6	54	47			8 x 900	2853.5	463	C	B	2xDN100	2xDN100		
BDD6L 905 A	433.9	343.7	169500	119400	51.8	34.3	55	48			10 x 900	1425.1	231	E	E	2xDN100	2xDN100		
BDD6L 905 B	517.9	392.2	156345	107843	34.7	21.3	55	48			10 x 900	2137.6	347	C	B	2xDN100	2xDN100		
BDD6L 905 C	578.9	423.5	149656	101997	79.7	45.9	55	48			10 x 900	2850.2	462	C	B	2xDN100	2xDN100		
BDD6L 905 D	602.8	429.8	143535	96963	55.2	30.4	55	48			10 x 900	3562.7	578	C	B	2xDN100	2xDN100		
BDD6Q 902 A	129.1	109.2	42663	33800	59.4	44.1	41	35	P=330W In=0.83A n=440min-1	P=185W In=0.38A n=330min-1	4 x 900	574.1	93	B	A	2xDN80	2xDN80		
BDD6Q 902 B	151.3	124.3	40616	31745	34.5	24.4	41	35			4 x 900	861.1	140	A	A	2xDN80	2xDN80		
BDD6Q 902 C	162.6	130.4	38712	29941	52.3	35.4	41	35			4 x 900	1148.2	186	A	A	2xDN80	2xDN80		
BDD6Q 903 A	192.9	163.1	63952	50656	52.0	38.6	43	37			6 x 900	857.8	139	B	A	2xDN100	2xDN100		
BDD6Q 903 B	228.3	187.4	60865	47559	60.8	43.1	43	37			6 x 900	1286.7	209	A	A	2xDN100	2xDN100		
BDD6Q 903 C	244.1	195.6	57996	44845	67.3	45.6	43	37			6 x 900	1715.5	278	A	A	2xDN100	2xDN100		
BDD6Q 904 A	256.7	217.1	85241	67512	48.7	36.2	44	38			8 x 900	1141.4	185	B	A	2xDN100	2xDN100		
BDD6Q 904 B	304.8	250.3	81113	63374	74.3	52.6	44	38			8 x 900	1712.1	278	A	A	2xDN100	2xDN100		
BDD6Q 904 C	324.3	260.0	77279	59748	50.0	33.9	44	38			8 x 900	2282.8	370	A	A	2xDN100	2xDN100		
BDD6Q 905 A	317.6	269.0	106531	84368	29.9	22.4	45	39			10 x 900	1425.1	231	B	A	2xDN100	2xDN100		
BDD6Q 905 B	380.0	312.0	101361	79188	61.4	43.5	45	39			10 x 900	2137.6	347	A	A	2xDN100	2xDN100		
BDD6Q 905 C	404.5	324.3	96562	74651	42.4	28.7	45	39			10 x 900	2850.2	462	A	A	2xDN100	2xDN100		
BDD6R 902 A	122.8	88.4	39785	25508	54.4	30.4	40	30			P=270W In=0.70A n=390min-1	P=140W In=0.32A n=250min-1	4 x 900	574.1	93	A	A	2xDN80	2xDN80
BDD6R 902 B	142.8	98.0	37772	23829	31.0	16.0	40	30					4 x 900	861.1	140	A	A	2xDN80	2xDN80
BDD6R 903 A	183.6	132.2	59635	38226	47.6	26.6	42	32					6 x 900	857.8	139	A	A	2xDN100	2xDN100
BDD6R 903 B	215.5	147.7	56601	35697	54.8	28.3	42	32					6 x 900	1286.7	209	A	A	2xDN100	2xDN100
BDD6R 904 A	244.3	175.9	79486	50943	44.6	24.9	43	33	8 x 900	1141.4			185	A	A	2xDN100	2xDN100		
BDD6R 904 B	287.7	197.2	75429	47565	66.9	34.6	43	33	8 x 900	1712.1			278	A	A	2xDN100	2xDN100		
BDD6R 905 A	302.5	218.0	99336	63660	27.6	15.4	44	34	10 x 900	1425.1			231	A	A	2xDN100	2xDN100		
BDD6R 905 B	358.7	245.9	94257	59433	55.3	28.6	44	34	10 x 900	2137.6			347	A	A	2xDN100	2xDN100		

Nominal capacities according to standard EN1048 (water Tair=25°C, Tin=40°C, Tout=35°C).*See the General Contents for more details.**Energy Efficiency Class: see "General Contents" for more details.

Model	Capacity [kW]		Airflow [m³/h]		Pressure Drop fluid [kPa]		Lp [dB(A)]*		Motor (3/400V-50Hz)		Fans N° x D [mm]	Surface m²	Tube volume dm³	E.E.C.**		Conn. Size			
	Δ	Y	Δ	Y	Δ	Y	Δ	Y	Δ	Y				Δ	Y	Inlet	Outlet		
Ø 1000																			
BDD6L1002A	236.6	204.5	114846	89768	50.6	39.1	59	54	P=2200W In=4.2A n=670min-1	P=1500W In=2.7A n=530min-1	4x1000	574.1	93	E	D	2xDN80	2xDN80		
BDD6L1002B	297.6	250.9	105496	81689	66.5	49.5	59	54			4x1000	861.1	140	D	D	2xDN80	2xDN80		
BDD6L1002C	330.0	272.1	97519	75075	52.3	37.3	59	54			4x1000	1148.2	186	D	C	2xDN80	2xDN80		
BDD6L1002D	347.4	281.5	90824	69653	62.7	43.5	59	54			4x1000	1435.2	233	D	C	2xDN80	2xDN80		
BDD6L1003A	356.4	308.1	172071	134475	65.6	50.7	61	56			6x1000	857.8	139	E	D	2xDN100	2xDN100		
BDD6L1003B	442.4	373.1	157984	122314	49.2	36.7	61	56			6x1000	1286.7	209	D	D	2xDN100	2xDN100		
BDD6L1003C	490.2	404.4	145987	112374	36.5	26.1	61	56			6x1000	1715.5	278	D	D	2xDN100	2xDN100		
BDD6L1003D	519.3	420.7	135931	104235	58.3	40.5	61	56			6x1000	2144.4	348	D	C	2xDN100	2xDN100		
BDD6L1004A	470.9	407.1	229294	179181	48.2	37.3	62	57			8x1000	1141.4	185	E	D	2xDN100	2xDN100		
BDD6L1004B	584.0	492.2	210472	162939	34.4	25.4	62	57			8x1000	1712.1	278	D	D	2xDN100	2xDN100		
BDD6L1004C	647.2	533.8	194455	149673	24.9	17.7	62	57			8x1000	2282.8	370	D	D	2xDN100	2xDN100		
BDD6L1004D	691.0	559.8	181035	138816	56.2	39.0	62	57			8x1000	2853.5	463	D	C	2xDN100	2xDN100		
BDD6L1005B	740.4	624.2	262959	203564	64.9	48.4	63	58			10x1000	2137.6	347	D	D	2xDN100	2xDN100		
BDD6L1005C	819.5	675.9	242922	186971	46.9	33.4	63	58			10x1000	2850.2	462	D	C	2xDN100	2xDN100		
BDD6L1005D	855.9	693.7	226142	173396	33.8	23.4	63	58			10x1000	3562.7	578	D	C	2xDN100	2xDN100		
BDD6Q 1002A	184.9	148.1	74318	52939	63.9	43.2	45	38	P=860W In=2A n=420 min-1	P=500W In=9.7A n=310 min-1	4x1000	574.1	93	C	B	2xDN80	2xDN80		
BDD6Q 1002B	220.1	169.0	66863	46815	67.1	42.2	45	38			4x1000	861.1	140	C	B	2xDN80	2xDN80		
BDD6Q 1002C	230.3	173.1	60052	42215	41.2	25.1	45	38			4x1000	1148.2	186	C	B	2xDN80	2xDN80		
BDD6Q 1003A	274.1	219.6	111330	79267	41.2	27.9	47	40			6x1000	857.8	139	C	B	2xDN100	2xDN100		
BDD6Q 1003B	329.1	252.7	100075	70064	65.0	40.9	47	40			6x1000	1286.7	209	C	B	2xDN100	2xDN100		
BDD6Q 1003C	344.5	259.1	89831	63162	41.9	25.5	47	40			6x1000	1715.5	278	C	B	2xDN100	2xDN100		
BDD6Q 1004A	362.2	290.3	148340	105595	30.3	20.5	48	41			8x1000	1141.4	185	C	B	2xDN100	2xDN100		
BDD6Q 1004B	438.1	336.4	133286	93314	64.0	40.2	48	41			8x1000	1712.1	278	C	B	2xDN100	2xDN100		
BDD6Q 1004C	458.7	345.0	119609	84109	42.3	25.8	48	41			8x1000	2282.8	370	C	B	2xDN100	2xDN100		
BDD6Q 1005A	459.3	367.9	185350	131922	57.3	38.7	49	42			10x1000	1425.1	231	C	B	2xDN100	2xDN100		
BDD6Q 1005B	541.9	416.5	166496	116564	37.6	23.7	49	42			10x1000	2137.6	347	C	B	2xDN100	2xDN100		
BDD6Q 1005C	578.1	434.1	149386	105056	79.5	48.0	49	42			10x1000	2850.2	462	C	B	2xDN100	2xDN100		
BDD6R 1002A	170.9	125.6	65708	41628	55.6	32.5	43	34			P=670W In=1.4A n=380 min-1	P=330W In=0.67A n=250 min-1	4x1000	574.1	93	C	B	2xDN80	2xDN80
BDD6R 1002B	200.1	140.1	58675	36862	56.7	30.0	43	34					4x1000	861.1	140	B	B	2xDN80	2xDN80
BDD6R 1003A	253.3	186.1	98422	62338	35.9	20.8	45	36					6x1000	857.8	139	C	B	2xDN100	2xDN100
BDD6R 1003B	299.2	209.5	87810	55163	54.9	29.0	45	36	6x1000	1286.7			209	B	B	2xDN100	2xDN100		
BDD6R 1004A	334.9	246.1	131134	83048	26.4	15.3	46	37	8x1000	1141.4			185	C	B	2xDN100	2xDN100		
BDD6R 1004B	398.3	278.8	116944	73463	54.0	28.6	46	37	8x1000	1712.1			278	B	B	2xDN100	2xDN100		
BDD6R 1005A	424.5	311.7	163847	103758	49.8	28.9	47	38	10x1000	1425.1			231	C	B	2xDN100	2xDN100		
BDD6R 1005B	492.8	345.4	146077	91764	31.8	16.9	47	38	10x1000	2137.6			347	B	B	2xDN100	2xDN100		

Nominal capacities according to standard EN1048 (water Tair=25°C, Tin=40°C, Tout=35°C).*See the General Contents for more details.**Energy Efficiency Class: see "General Contents" for more details.

BDD/BDD6 - Double Fan Row

Drawings

Serie	Weight [kg]		Dimensions (mm)					N° feet	
	BDD	BDD6	A	B	C Ø 800	D	G	V	H
BDD_802A	580	602	3905	3955	3475(V)/3404(H)	-	2290(V)/1220(H)	2	4
BDD_802B	600	623	3905	3955	3475(V)/3404(H)	-	2290(V)/1220(H)	2	4
BDD_802C	646	670	3905	3955	3475(V)/3404(H)	-	2290(V)/1220(H)	2	4
BDD_802D	711	738	3905	3955	3475(V)/3404(H)	-	2290(V)/1220(H)	2	4
BDD_803A	713	740	5655	5705	5225(V)/5154(H)	-	2290(V)/1220(H)	2	4
BDD_803B	820	851	5655	5705	5225(V)/5154(H)	-	2290(V)/1220(H)	2	4
BDD_803C	920	955	5655	5705	5225(V)/5154(H)	-	2290(V)/1220(H)	2	4
BDD_803D	1012	1050	5655	5705	5225(V)/5154(H)	-	2290(V)/1220(H)	2	4
BDD_804A	1020	1058	7405	7455	3475(V)/3404(H)	3500	2290(V)/1220(H)	3	6
BDD_804B	1062	1102	7405	7455	3475(V)/3404(H)	3500	2290(V)/1220(H)	3	6
BDD_804C	1196	1241	7405	7455	3475(V)/3404(H)	3500	2290(V)/1220(H)	3	6
BDD_804D	1316	1365	7405	7455	3475(V)/3404(H)	3500	2290(V)/1220(H)	3	6
BDD_805A	1330	1380	9155	9205	3475(V)/3404(H)	1775	2290(V)/1220(H)	4	8
BDD_805B	1175	1219	9155	9205	3475(V)/3404(H)	1775	2290(V)/1220(H)	4	8
BDD_805C	1473	1528	9155	9205	3475(V)/3404(H)	1775	2290(V)/1220(H)	4	8
BDD_805D	1620	1681	9155	9205	3475(V)/3404(H)	1775	2290(V)/1220(H)	4	8
BDD_806A	1640	1702	10905	10955	3475(V)/3404(H)	3525	2290(V)/1220(H)	4	8
BDD_806B	1396	1448	10905	10955	3475(V)/3404(H)	3525	2290(V)/1220(H)	4	8
BDD_806C	1745	1810	10905	10955	3475(V)/3404(H)	3525	2290(V)/1220(H)	4	8
BDD_806D	1920	1992	10905	10955	3475(V)/3404(H)	3525	2290(V)/1220(H)	4	8
Ø 910									
BDD_902A	951	987	4605	4655	4175(V)/4104(H)	-	2290(V)/1290(H)	2	4
BDD_902B	870	903	4605	4655	4175(V)/4104(H)	-	2290(V)/1290(H)	2	4
BDD_902C	930	965	4605	4655	4175(V)/4104(H)	-	2290(V)/1290(H)	2	4
BDD_902D	1000	1038	4605	4655	4175(V)/4104(H)	-	2290(V)/1290(H)	2	4
BDD_903A	1050	1089	6705	6755	6275(V)/6204(H)	-	2290(V)/1290(H)	2	4
BDD_903B	1070	1110	6705	6755	6275(V)/6204(H)	-	2290(V)/1290(H)	2	4
BDD_903C	1163	1207	6705	6755	6275(V)/6204(H)	-	2290(V)/1290(H)	2	4
BDD_903D	1249	1296	6705	6755	6275(V)/6204(H)	-	2290(V)/1290(H)	2	4
BDD_904A	1300	1349	8805	8855	4175(V)/4104(H)	4200	2290(V)/1290(H)	3	6
BDD_904B	1438	1492	8805	8855	4175(V)/4104(H)	4200	2290(V)/1290(H)	3	6
BDD_904C	1530	1587	8805	8855	4175(V)/4104(H)	4200	2290(V)/1290(H)	3	6
BDD_904D	1643	1705	8805	8855	4175(V)/4104(H)	4200	2290(V)/1290(H)	3	6
BDD_905A	1625	1686	10905	10955	4175(V)/4104(H)	2125(V)/2196(H)	2290(V)/1290(H)	4	8
BDD_905B	1890	1961	10905	10955	4175(V)/4104(H)	2125(V)/2196(H)	2290(V)/1290(H)	4	8
BDD_905C	2080	2158	10905	10955	4175(V)/4104(H)	2125(V)/2196(H)	2290(V)/1290(H)	4	8
BDD_905D	2234	2318	10905	10955	4175(V)/4104(H)	2125(V)/2196(H)	2290(V)/1290(H)	4	8
Ø 1000									
BDD_1002A	951	987	4605	4655	4175(V)/4104(H)	-	2290(V)/1290(H)	2	4
BDD_1002B	870	903	4605	4655	4175(V)/4104(H)	-	2290(V)/1290(H)	2	4
BDD_1002C	930	965	4605	4655	4175(V)/4104(H)	-	2290(V)/1290(H)	2	4
BDD_1002D	1000	1038	4605	4655	4175(V)/4104(H)	-	2290(V)/1290(H)	2	4
BDD_1003A	1050	1089	6705	6755	6275(V)/6204(H)	-	2290(V)/1290(H)	2	4
BDD_1003B	1070	1110	6705	6755	6275(V)/6204(H)	-	2290(V)/1290(H)	2	4
BDD_1003C	1163	1207	6705	6755	6275(V)/6204(H)	-	2290(V)/1290(H)	2	4
BDD_1003D	1249	1296	6705	6755	6275(V)/6204(H)	-	2290(V)/1290(H)	2	4
BDD_1004A	1300	1349	8805	8855	4175(V)/4104(H)	4200	2290(V)/1290(H)	3	6
BDD_1004B	1438	1492	8805	8855	4175(V)/4104(H)	4200	2290(V)/1290(H)	3	6
BDD_1004C	1530	1587	8805	8855	4175(V)/4104(H)	4200	2290(V)/1290(H)	3	6
BDD_1004D	1643	1705	8805	8855	4175(V)/4104(H)	4200	2290(V)/1290(H)	3	6
BDD_1005A	1625	1686	10905	10955	4175(V)/4104(H)	2125(V)/2196(H)	2290(V)/1290(H)	4	8
BDD_1005B	1890	1961	10905	10955	4175(V)/4104(H)	2125(V)/2196(H)	2290(V)/1290(H)	4	8
BDD_1005C	2080	2158	10905	10955	4175(V)/4104(H)	2125(V)/2196(H)	2290(V)/1290(H)	4	8
BDD_1005D	2234	2318	10905	10955	4175(V)/4104(H)	2125(V)/2196(H)	2290(V)/1290(H)	4	8

Standard Feet 500 mm.

We reserve the right to change our technical data without prior notice.

VERTICAL POSITION	HORIZONTAL POSITION
-------------------	---------------------

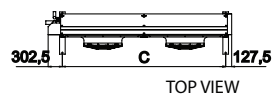
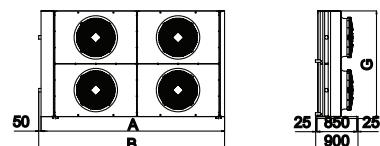
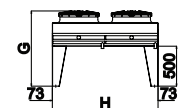
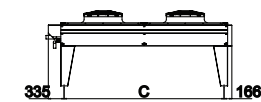
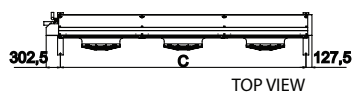
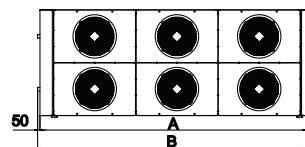
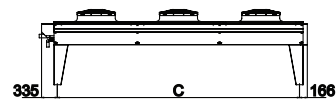
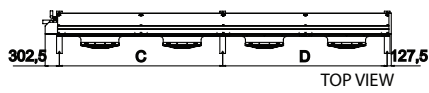
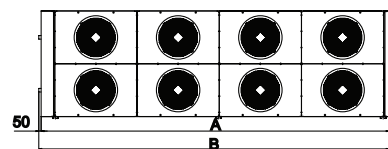
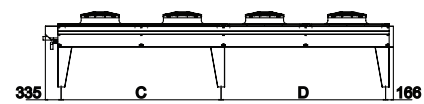
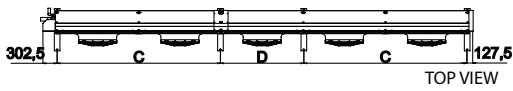
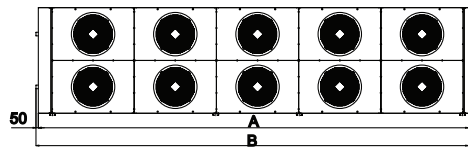
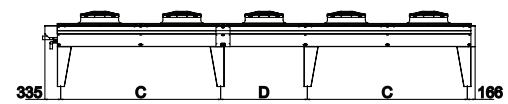
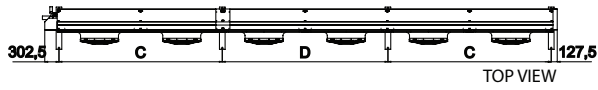
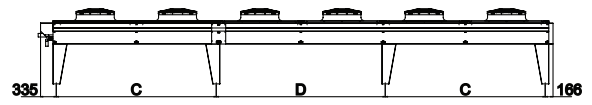
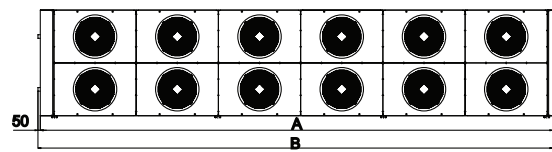

BDD/BDD6 - Double Fan Row

Options

Motor fans



(a) Fan motor 400 V/3ph - 60Hz, IP54: Q/R for Ø 800/910/1000, S/L only for Ø 800/910
 (b) Fan motor 460 V/3ph - 60Hz, IP54: Q/R for Ø 800/910/1000, S/L only for Ø 800/910

Model:
 Ø 800 (a,b)
 Ø 910(a,b)
 Ø1000 (a,b)

Local safety switch wired



See Electrical Data Page.

Model:
 All Models

Local safety switch EMC

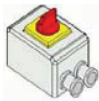

See Electrical Data Page.

Model:
 All Models

Terminal Box

See Electrical Data Page.

Model:
 All Models

Switchboard and cabling		
	<p>Function</p> <p>Switchboard for supply and control of fan motors.</p> <p>A switchboard can supply up to 8 individual motors or 8 paired motors (i.e. max. of 16 motors).</p> <p>Switchboard and cabling are supplied as standard for vertical installation of the unit.</p> <p>If you have different needs, please specify these when placing your order.</p> <p>Operating conditions</p> <p>Type of installation: External wall mounted</p> <p>Protection degree: IP55 door closed</p> <p>Climate: Normal</p> <p>Operating temperature: $-10 \div +35^{\circ}\text{C}$ (base) $-25 \div +50^{\circ}\text{C}$ (with optionals)</p> <p>Ambient relative humidity: <95%</p> <p>Altitude: <1000metres above sea level</p> <p>Electrical data</p> <p>Insulating nominal voltage: 690V</p> <p>Operating voltage: 3Ph. 400Vac</p> <p>Frequency: 50Hz</p> <p>Auxiliaries voltage: 24-230V</p> <p>Nominal current: Max 80A</p> <p>Mechanical data</p> <p>Material: Pre-painted galvanized steel</p> <p>Fixing plate: Sheet of steel (min. thickness 15/10 Sendzimir galvanized)</p> <p>Gasket: Polyurethane</p> <p>Door: opening more than 180°.</p> <p>Colour: RAL 7035</p> <p>Cable gland: metric ISO</p>	<p>Model:</p> <p>All Models</p>
Switchboard Options		
	<p>R Anti-condensate resistor 230Vac (operating temperature $-25 \div +35^{\circ}\text{C}$)</p> <p>C Cooling fan 230VAC (operating temperature $-10 \div +50^{\circ}\text{C}$)</p> <p>F Cooling fan + anti-condensate resistor</p>	<p>Model:</p> <p>All Models</p>
Switchboard with Fan Speed control		
	<p>Switchboard and cabling, including an electronic fan speed controller (equipment that checks and regulates the speed rotation of the fan's motor, keeping the temperature for dry coolers within the range of pre-defined values). Constant control of the fan speed is achieved by variation of the electrical supply by phase-cut, as determined by the probe signal. The fan speed controller comes pre-connected to the switchboard. If you have different needs, please specify these when placing your order.</p>	<p>Model:</p> <p>All Models</p>
Switchboard with Fan Step control		
	<p>Switchboard and cabling, including an automatic on/off switch that checks and regulates the speed rotation of the fan's motor, keeping the temperature for dry coolers within the range of preset values. Control of the fan speed is achieved by variation of the electrical supply by the ON/OFF device, as determined by the probe signal. The fan step controller comes pre-connected to the switchboard. If you have different needs, please specify these when placing your order.</p>	<p>Model:</p> <p>All Models</p>
Switchboard with Frequency Converter (Inverter)		
	<p>See Electrical Data Page.</p>	<p>Model:</p> <p>All Models</p>
Coil Treatment / Material		
	<p>Thermoguard for industrial or sea coast application.</p> <p>Aluminium fins, pre-coated.</p> <p>Copper fins.</p> <p>Application Use: More information on corrosion prevention can be found in the Miscellaneous section.</p>	<p>Model:</p> <p>All Models</p>

Non-standard fin spacing

	The standard fin spacing is 2.1mm. Alternative: 2.5mm and 3.2mm	Model: All Models
--	--	-----------------------------

Spray water

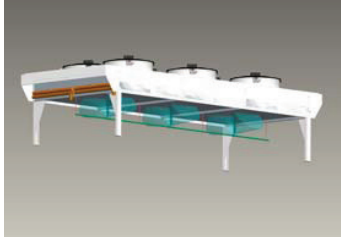

Consisting of a pipe system with several fitted spraying nozzles that nebulise water in the air suction of the coil. Spray water comes mounted on delivery.	Model: All Models
---	-----------------------------

Feet

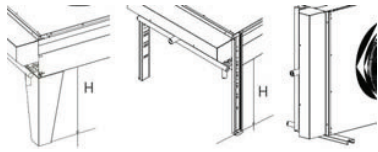

V Vertical Position H Horizontal Position (500 and 850mm) A Feet adjustable from 350 to 950cm	Model: All Models
---	-----------------------------

Vibration Dampers

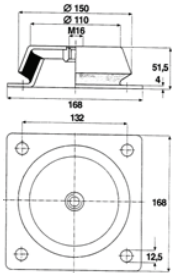

<table border="1"> <thead> <tr> <th>Type</th> <th>H mm</th> <th>A mm</th> <th>B mm</th> <th>C mm</th> <th>D mm</th> <th>Weight Kg</th> </tr> </thead> <tbody> <tr> <td>Single Row</td> <td>51.5</td> <td>132</td> <td>168</td> <td>M16</td> <td>12.5</td> <td>2.15</td> </tr> </tbody> </table> <p>Nuts and bolts are not included with these dampers.</p>	Type	H mm	A mm	B mm	C mm	D mm	Weight Kg	Single Row	51.5	132	168	M16	12.5	2.15	Model: All Models
Type	H mm	A mm	B mm	C mm	D mm	Weight Kg									
Single Row	51.5	132	168	M16	12.5	2.15									

BDD/BDD6 - Double Fan Row

Electrical Data

Safety Switch

Function

Local safety switch and cabling for each electric fan motor.

General data

Power Supply:

- 400VAC, 50/60Hz
- Max fuse 16A

Number of poles: 3P

Cabinet Material: Plastic Case

Cabinet Colour: Grey (Yellow-Red Knob)

Protection Class: Min IP65

Ambient Temp.: min. -25°C, max. +50°C

Weight: Approx. 0.4Kg

Dimensions

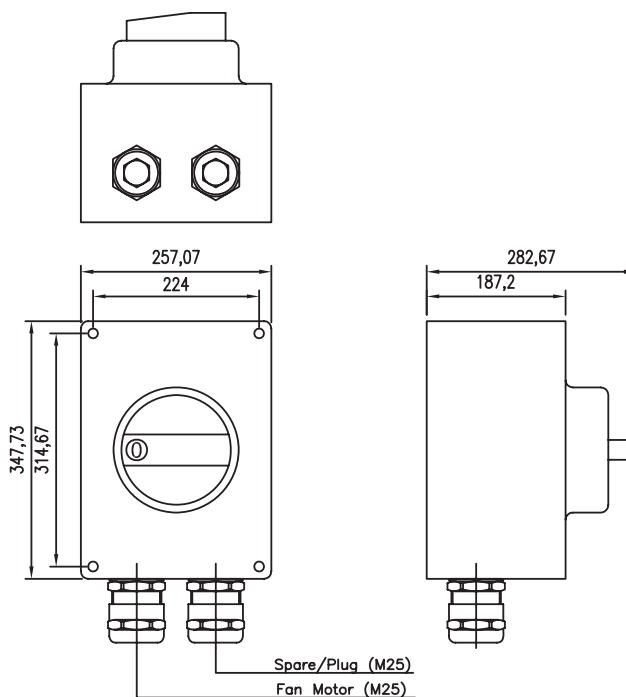

Safety Switch EMC

Function

Local safety switch and cabling for each electric fan motor.

General data

Power Supply:

- 400VAC, 50/60Hz
- Max fuse 16A

Number of poles: 3P

Cabinet Material: Plastic case with internal copper-painted

Cabinet Colour: Grey (Yellow-Red Knob)

Protection Class: Min IP65

Ambient Temp.: min. -25°C, max. +50°C

Weight: Approx. 0.4Kg

Dimensions

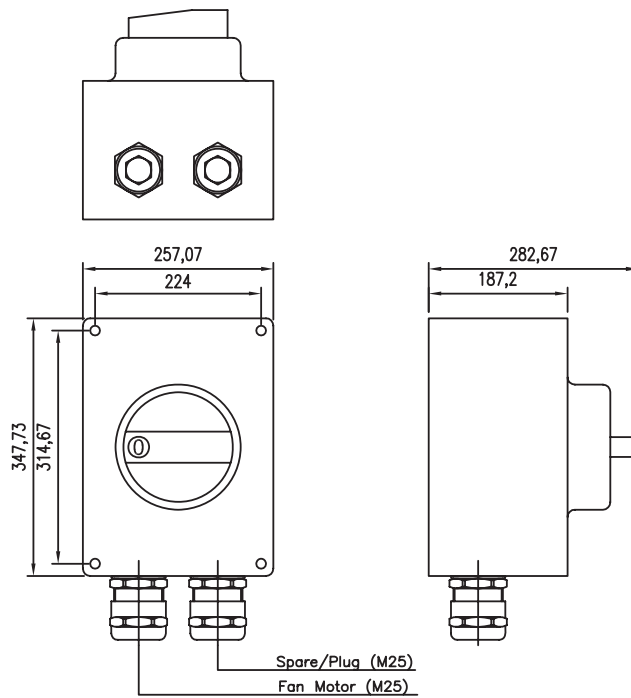

Terminal Box

Function

Connection box for electric fan motor

General data

Material: Plastic
 IP Protection Class: Min RAL 7035
 Colour: Grey RAL 7035
 Insulation Class: II
 Ambient Temp.: min. -40°C, max. +80°C
 Weight: Approx. 0.5Kg.

Dimensions

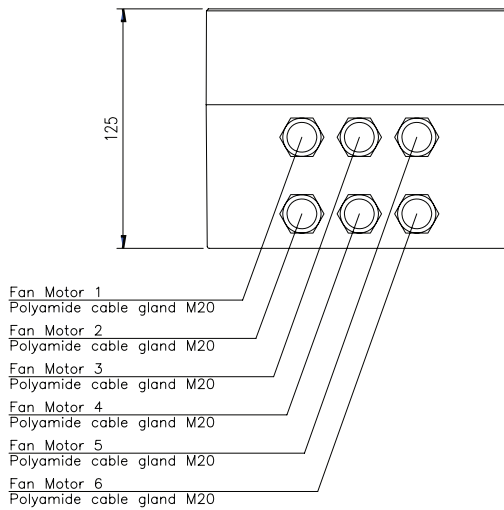
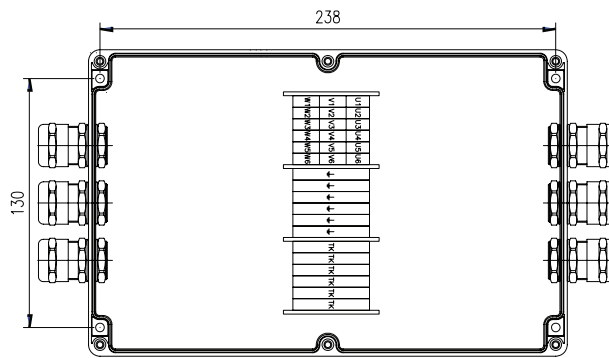

Switch Board (Control Panel)

Function

Basic Version for Horizontal Installation

General data

Cabinet Material: Sheet steel 15/10mm zinc-coated

Internal Plate: Sheet steel 20/10mm zinc-coated

Protection Class: IP 55

Cabinet Colour: RAL 7035, light grey polyester paint

Cabinet Doors: Opening angle 110°

Ambient Temp.:

- min. -10°C, max. +35°C standard
- min. -25°C, max. +35°C with electrical heater
- min. -10°C, max. +50°C with cooling fan
- min. -25°C, max. +50°C with heater and fan

Cables included: Bottom position with cable glands.

Dimensions

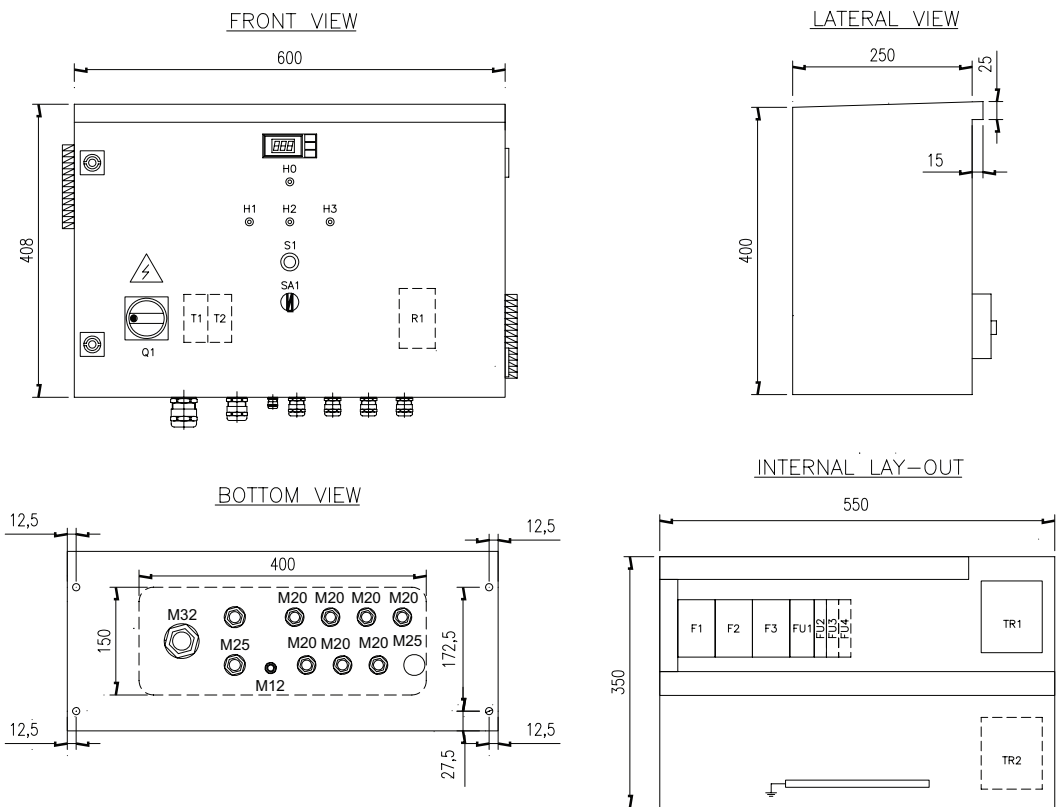

Labels list

- | | |
|-----------------------------------|--|
| H0 VOLTAGE BOARD ON | Q1 MAIN SWITCH |
| H1 FAN MOTOR 1–2 RUNNING (OPTION) | TC1 TEMPERATURE/PRESSURE CONTROLLER (OPTION) |
| H2 FAN MOTOR 3–4 RUNNING (OPTION) | S1 RESET (OPTION) |
| H3 FAN MOTOR 5–6 RUNNING (OPTION) | SA1 MAN – AUT SELECTION (OPTION) |

Electric wiring diagram

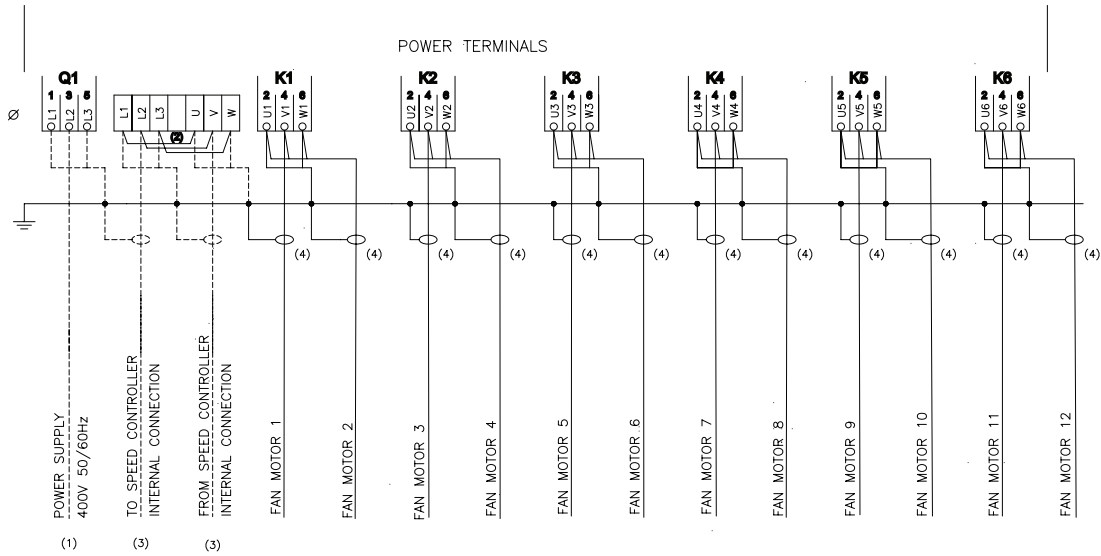

- NOTE:**
- (1) EXTERNAL SHORT CIRCUIT PROTECTION MAX FUSE
 - (2) REMOVE JUMPERS WHEN SPEED CONTROLLER IS ORDERED
 - (3) NOT MOUNTED WHEN FAN SPEED CONTROLLER IS ORDERED
 - (4) SHIELDED CABLE TO BE USED ONLY WHEN EMC CABLING OPTION IS REQUESTED
- CABLE NOT INCLUDED IN ALFA LAVAL DELIVERY
 _____ CABLE INCLUDED IN ALFA LAVAL DELIVERY

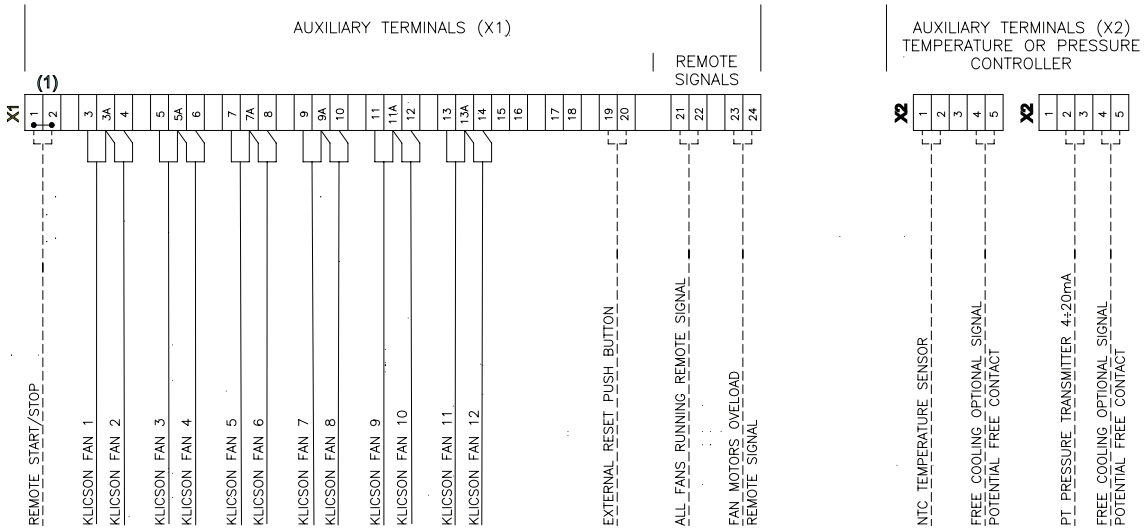

- NOTE:**
- (1) REMOVE JUMPER WHEN USED

Electric wiring diagram

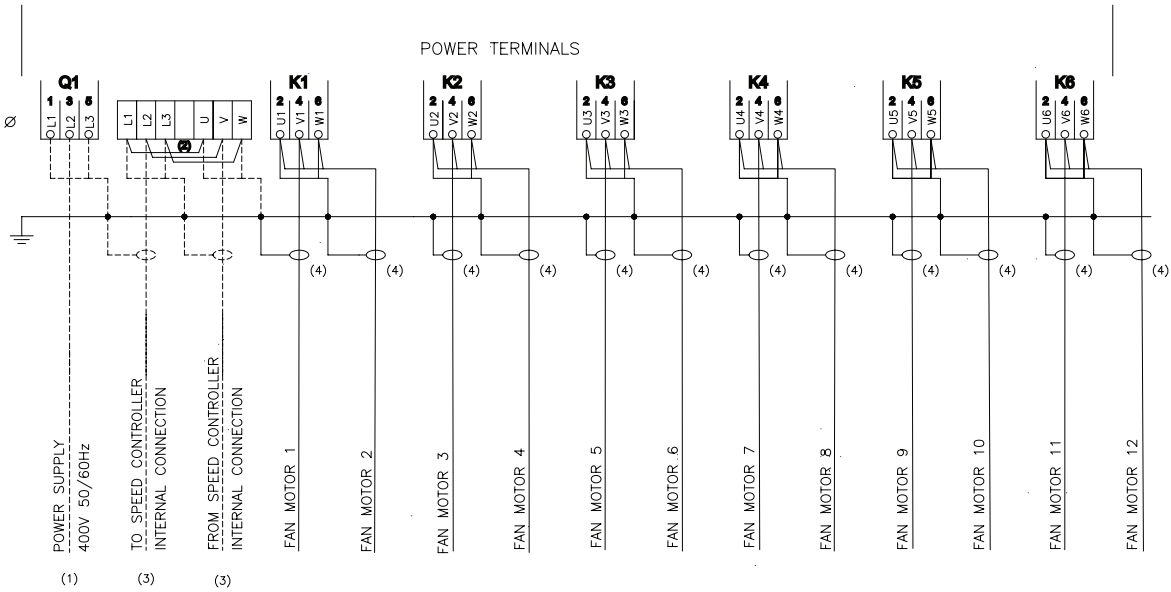

- NOTE:**
- (1) EXTERNAL SHORT CIRCUIT PROTECTION MAX FUSE
 - (2) REMOVE JUMPERS WHEN SPEED CONTROLLER IS ORDERED
 - (3) NOT MOUNTED WHEN FAN SPEED CONTROLLER IS ORDERED
 - (4) SHIELDED CABLE TO BE USED ONLY WHEN EMC CABLING OPTION IS REQUESTED

----- CABLE NOT INCLUDED IN ALFA LAVAL DELIVERY
 _____ CABLE INCLUDED IN ALFA LAVAL DELIVERY

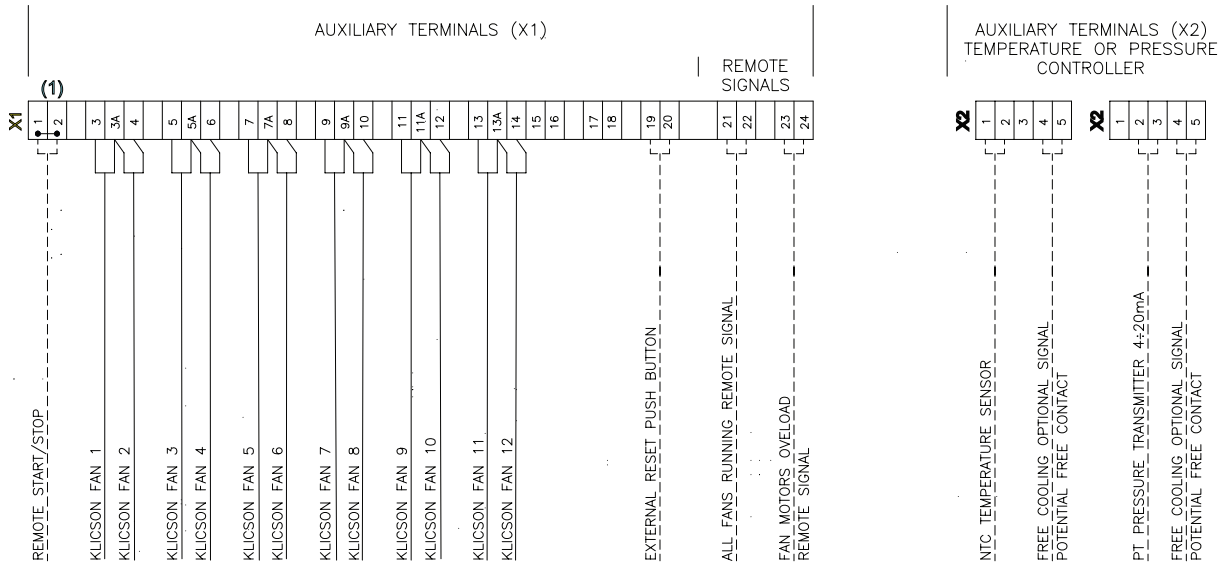

- NOTE:**
- (1) REMOVE JUMPER WHEN USED

Current Distribution

Function

Current distributors are available as optional accessories. Numerous fans can be connected. In combination with Fcontrol frequency inverters, we can deliver the current distribution with both main switch and bypass function. Features: The current distributor is equipped with plastic housing IP54 and motor protection units STDT16E with status signal contacts ZB. It is possible to lock the motor protection units with a padlock and use them as repair switches. Fans are directly connected to the motor protection units. Line protection is guaranteed through the integrated short-circuit release. Terminals for supplying the controller output are also integrated. The current distributors are suitable for external mounting (e.g. direct mounting at refrigeration units). It's easy to see the switch position of the motor protection units through the coloured, transparent plastic door.

General data

Current distributor with main switch and bypass function:

- The controller is supplied by the current distributor
- Main switch: 100% - 0 -1
- In position 100%, the connection to the controller output is switched off. This version is for Fcontrol frequency inverters .
- Rated current: Up to 80A

Dimensions

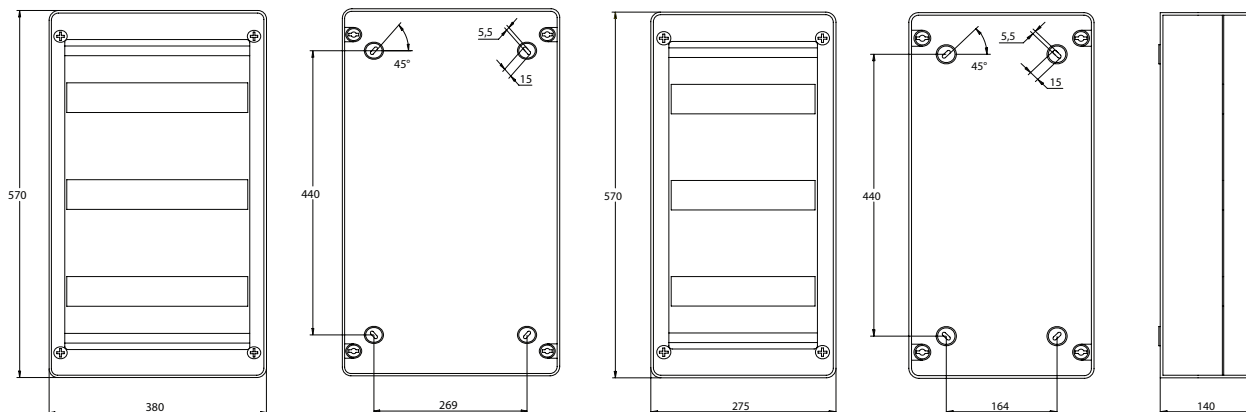

Electric wiring diagram

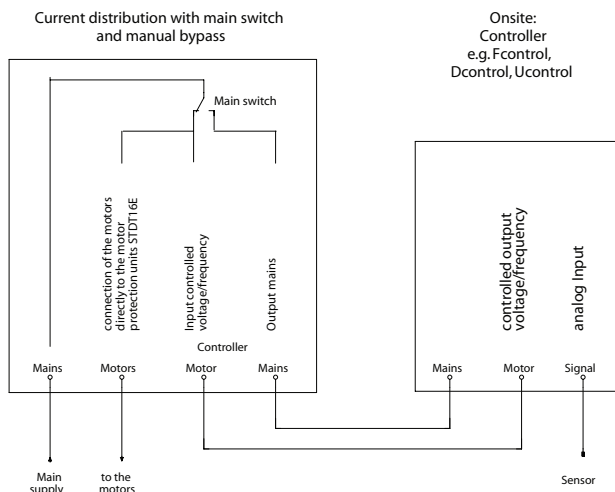

Frequency Converter (Inverter)

Function

Frequency inverter (incl. sine filter) for 3~ motors. Universal controller for refrigeration and air conditioning line input 3~ 208-480V, housing IP54, internal display.

- Speed controller with manual adjustment of output voltage at the unit or via external signal, 2-step operation;
- Temperature control for liquid coolers;
- Pressure control refrigeration (input for refrigerant) for: condensers, dual-circuit condensers;

General data

Equipment/Function

- Integrated SINEFILTER between phase to phase and phase to earth.
- Absolute parallel operation of fans, with no risk of damage to the motor. **Screened motor cables are not required.**
- Integrated process controller (PID free programmable).
- LCD multifunction display with plain language text.
- 2x Analogue Input (0-10 V, 0-20 mA, 4-20 mA, temperature sensor type TF):
 - Analogue 1 for setting of sensor signal.
 - Analogue 2 programmable function for: external set-point, difference value to sensor 1, comparison value (dual-circuit condenser), averaging, and setpoint lowering according to outdoor temperature.
- 1x output 0-10V, programmable function: Constant voltage, proportional modulation, proportional input signal, group control, controller 2.
- 2x digital inputs, programmable function: enable (on / off), external fault, limit output, input 1/2, set-point 1/2, setting internal / external, automatic control / speed manual, reverse control function ("heating" / "cooling"), reset, setting max. speed.
- 2x relay outputs, programmable function: operating indication, fault indication, external fault from digital input, limit modulation, limit input signal, limit offset (deviation actual value setpoint), group control .
- Total motor protection using thermocontact / thermistor connection.
- Interface system with RS485 Interface (MODBUS) or LON® is another alternative option.

Technical data

- Line voltage 3~ 208 BND_480V (-15% / +10%), 50/60Hz.

Rated current*/A	4	8	13	18	22	32	40
Max. line fuse/A	10	10	16	20	25	35	50
Max. heat dissipation*/W	130	210	350	440	540	950	1.100
Weight/Kg	8.8	9.0	22.8	25.4	28.1	29.5	31.8

*at line voltage 400V / 50Hz (for FXDM40A rated current - only possible for fans with $\cos \phi < 0.8$).

- Maximum output frequency 100Hz (for FXDM40, max. 60Hz).
- Clock frequency 16 kHz.
- Max. permissible ambient temperature 40°C (up to 55°C with derating).
- Voltage supply for sensors +24V ±20% (I_{max.} 120 mA).
- Permissible rel. humidity 85% with no condensation .
- Interference emission EN 61000-6-3 1 (unshielded motor cable).
- Interference immunity EN 61000-6-2.

Settings

- Quick start-up with pre-programming modes.
- Set-point 1, set-point 2, manual mode.
- Min. and max. speed, speed limitation e.g. for night operation.
- Group control (via relay or 0-10V signal output).
- Limits: Modulation, input signal, offset (deviation set to actual value).
- Set protection, save user settings.
- Readout events memory (checking the fault log).
- Masking up to 3 settable speed ranges.
- Minimum rate of air on / off.
- Edge frequency, max. frequency / voltage, start voltage.
- U/f characteristics: quadratic or linear.
- Menu language: English, German, Italian, Swedish, etc.
- Inverting: Inputs analogue and digital, analogue out, relays.

BDD/BDD6 - Double Fan Row

Code description

Code No.

	1	2	3	4
BDD or BDD6	S	80	2	A

1) Type of noise level (number of dB(A) to reduce compared with "base" version)

	Turbo noise level T	Standard noise level S*	Low noise level L*	Quiet noise level Q*	Residential noise level R*
Fan diameter Ø 800mm	-	base	-7	-16	-20
Fan diameter Ø 910 mm	base	-2	-9	-19	-20
Fan diameter Ø 1 000 mm	-	-	base	-14	-16

2) Fan diameter Ø

80	800 mm
90	910 mm
100	1 000 mm

3) Number of Fans (* available in this version)

1	Ø 800, 910 and 1000mm fan
2	
3	
4	
5	
6	Ø 800mm fan only

4) Number of coil rows

A	2
B	3
C	4
D	5

General Alfa Select Air Legend

Description 1		Description 2	
D	D fan cabling (three phase)	BSFT	Basic Switch Board + Speed Control Temp. + Signal
Y	Y fan cabling (three phase)	BI	Basic Switch Board + Frequency Converter (Inverter)
D/Y	D/Y fan cabling (three phase), single speed fan motor	BSI	Basic Switch Board + Frequency Converter (Inverter) + Signal
S	Single phase	C	Switch Board + Cooling fan
P	Packaged on a pallet	R	Switch Board + Resistor
CR	Packaged in a crate	F	Switch Board + Cooling fan + Resistor
BO	Packaged in a box	PT	Ammonia pump top
Feet	Feet-mounted	PB	Ammonia pump bottom
SW	Safety Switch	AL	Aluminium casing
CB	Terminal Box	SS	Stainless Steel casing
B	Basic Switch Board	AP	Pre-painted Aluminium casing
BS	Basic Switch Board + Signal	PL	Plastic casing
BP	Basic Switch Board + Step Control Pressure	E	Electrical defrost
PT	Basic Switch Board + Step Control Temperature	LE	Low Electrical defrost
BSP	Basic Switch Board + Step Control Pressure + Signal	A	Air Defrost
BST	Basic Switch Board + Step Control Temp. + Signal	HG	Hot Gas Defrost
BFP	Basic Switch Board + Speed Control Pressure	HG+E	Hot Gas Defrost + Electrical Defrost on drip tray
BFT	Basic Switch Board + Speed Control Temperature	W	Water Defrost
BSFP	Basic Switch Board + Speed Control Pres. + Signal	W+E	Water Defrost + Electrical Defrost on drip tray
		AL	Aluminium fin
		CU	Copper fin
		PR	Pre-coated fin
		SS	Stainless steel tube
		TH	Thermoguard treatment
		CF	Cataphoresis treatment
		SC	Sub-cooling circuit
		KW	Spray water kit
		FL	Flanges
		FH	Fan ring heater
		IS	Insulated Drip Tray
		RH	Reheating coil
		SR	Air socket adapter ring
		CW	Air throw fan cowling
		ER	120° elbow reducer
		HN	Hinged fan cowling

Note: valid for the entire product range

AlfaGreen Dry Coolers

General Content

General Features

A dry cooler is a forced convection air-cooled fluid cooler, designed for outdoor installation. Air is forced over the finned coil which contains the working fluid such as a water and glycol mix. When determining the working fluid, consideration must be given to the lowest possible ambient temperature that could be experienced by the unit, in order to reduce the risk of freezing the working fluid. All products are designed to satisfy both commercial and industrial refrigeration, air conditioning, and retail refrigeration. Dry coolers are available in the following versions:

- Vertical installation (V)
- Horizontal installation (H)

Relative footprint, low consumption and low noise levels are the keys to this series' success.

Certifications and reliability

All Dry coolers are guaranteed by Eurovent "Certify All". Alfa Laval quality systems fully comply with ISO 9001, and all of our products are manufactured in strict accordance with CE regulations.

Capacity

The standard conditions stated in the catalogue are in accordance with EN 1048 (water, T.air= 25°C, Tin= 40°C, Tout= 35°C). All models have many circuiting options which can be selected to optimise duty with required fluid pressure drops and flow rates. Due to the multiple combinations of temperatures, flow rates and working fluids that can be encountered, it is not possible to display all the capacities in the catalogue.

How to determine the dry cooler's capacity:

Capacity required (e.g. 34%) = Nominal Capacity. (water) x 1.07 x F1 x F2

Altitude (m)	0	500	1000	1500	2000
F1	1	1,028	1,06	1,09	1,12

Fin material	Al	Al Prv	Cu
F2	1	1,03	0,97

Against Freezing

Given that the tubes are permanently in a horizontal position, it cannot be guaranteed that they drain completely when stoppages occur. As a result of this, a dry cooler containing water must be protected against freezing with an adequate amount of glycol.

Tube Protection



Due to the thermal expansion of the copper pipes, all metal sheets are equipped with an aluminium plate with collars. This plate supports the tube and therefore the pipes must not come into contact with the metal sheets. With this solution, the vibrations and thermal expansion are absorbed by the aluminium sheet. Leaks caused by friction cannot occur. The rigidity of the coil is sustained effectively.

Energy Efficiency Class

Energy efficiency class of air cooled condensers		
Class	Energy consumption	R
A	Extremely low	R>110
B	Very low	70≤R<110
C	Low	45≤R<70
D	Medium	30≤R<45
E	High	R<30

R = Condenser capacity (ΔT15K) / motor power consumption.

Test and cleaning

Coils are cleaned thoroughly in order to remove any traces of oil. Each heat exchanger undergoes a pressure and leak test with dry air at 10bar (PS= 9bar).



Sound Data

The sound pressure level is based on the calculation (according to EN 13487) of the sound pressure level on the surface of a cuboid area which is at a 10 metre distance and is parallel to the reference envelope of the sound source. (Standard sound pressure level; annex C EN 13487)

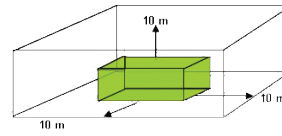

Sound pressure correction for distances other than 10 metres.

Distance (m)	2	3	4	5	7	10	15	20	30	40	50	60	80
Correction dB(A)	11	8,5	7	5	2,5	0	-3	-5,5	-9	-11	-12	-14	-16

Sound pressure level for several fans at nominal speed rating.

N° units	2	3	4	5	6	7	8	9	10
dB(A)	3	5	6	7	8	8,5	9	9,5	10

To calculate the sound pressure level, take the sound power of the individual fans according to their position, and calculate the sound propagation taking into consideration the local and ambient conditions. Speed change, start-up and control noises are not taken into account.

Fan Model	Speed rpm		Total Lw dB(A)		LW octave band spectrum dB(A)															
					63Hz		125Hz		250Hz		500Hz		1 000Hz		2 000Hz		4 000Hz		8 000Hz	
Connection	Δ	Y	Δ	Y	Δ	Y	Δ	Y	Δ	Y	Δ	Y	Δ	Y	Δ	Y	Δ	Y	Δ	Y
500 S	1310	1000	77	71	-	-	48	54	54	57	66	58	69	64	66	60	60	52	50	42
500 L	900	640	68	61	-	-	46	39	49	46	55	49	60	53	57	48	49	41	38	30
500 Q	670	520	60	56	-	-	38	39	46	43	49	45	52	48	48	42	40	34	30	28

Guarantee

All our products are protected under warranty for 18 months from the shipping date. If a defect should occur within the warranty period, please return the equipment or part to our factory free of charge where we will repair or replace the goods, depending on what is required. Unfortunately, We cannot take responsibility for damage caused by the misuse or incorrect installation of our products. Brochure subject to technical changes without prior notice



We recommend that you use the Alfa Select Air software for a precise thermal and mechanical design.



DC - Single Fan Row

Product description

Application

Refrigeration of liquids for:

- industrial refrigeration;
- food, power;
- process & general industry;
- air conditioning.

Standard design

Coil

The heat exchanger gives heat transfer with minimal fluid volume, as a result of new fin corrugation developed by Alfa Laval, combined with smooth tubes. The heat exchanger is manufactured with aluminium fins and copper tubes with a nominal diameter of 3/8". The standard fin spacing is 2.1mm.

Casing

Casework is made from galvanized steel sheets painted with an epoxy finish, RAL 9002. New frame design provides greater rigidity for heavy applications. The new system protects the heat exchanger tubes completely during transportation and against vibration and thermal expansion while in operation. Supports manufactured in galvanized steel, with optimized length to permit uniform air suction in the coil.

Benefits

- Low power consumption fan motor
- Low noise level
- Wide range of capacities and solutions.
- Eurovent certified

Options

- Fan motor 1 ph 230V-50/60Hz
- Fan Motor 460/3ph-60Hz IP54
- Local safety switch wired

Fans

Fan motor diameter 500mm has a 400V-50Hz three-phase motor. The motors come with external rotors which comply with VDE 0530/12.84. Protection class IP 54 according to DIN 40050. Integrated thermo contacts provide reliable protection against any thermal overloads. The bell mouths optimise the performance of the fan motors and minimise both the noise level and power consumption. There are 3 fan motor noise levels available: (S) standard, (L) low and (Q) quiet. The fans are suitable for operation in air temperatures between -40°C and +40°C. For air temperatures lower than +20°C, the full load current (FLC) can be calculated using the correction factor table. The overload protection should have a 20% margin to accommodate fan motor supplier variations.

T [°C]	20	10	0	-10	-15	-20	-25	-30
Fc	1	1,04	1,08	1,12	1,14	1,16	1,18	1,2

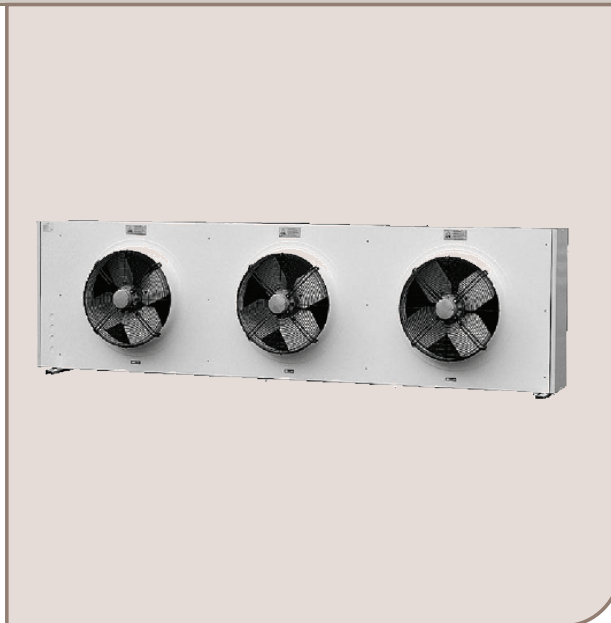

- Terminal Box for electric power connection
- Fan speed control 230V-1ph and 400V-3ph
- Fan speed control and cabling
- Thermoguard treatment
- Pre-coated aluminium fins
- Copper
- Non-standard fin spacing
- Flanges
- Vibration dampers

Model	Capacity		Airflow		Fluid flow		Pressure drop fluid		Lp [dB(A)]*		Motor data (3/400V-50Hz)		Fans	Sur-face	Tube vol-ume	Conn.		N° circuits
	kW		m³/h		m³/h		kPa		(10m)		Δ	Y				mm		
	Δ	Y	Δ	Y	Δ	Y	Δ	Y	Δ	Y	Δ	Y	N° x D [mm]	m²	dm³	Inlet	Outlet	
Ø 500																		
DCS501A	18,83	16,07	7864	6183	3,28	2,8	31,24	23,59	44	38	P=780W I=1.35A n=1310min-1	P=550W I=0.94A n=1000min-1	1 x 500	28,1	6	1"	1"	8_C
DCS501B	23,39	19,24	7344	5641	4,1	3,35	50,05	35,37	44	38			1 x 500	42,2	8	1"	1"	9_C
DCS501C	25,68	20,47	6879	5183	4,5	3,55	58,52	39,25	44	38			1 x 500	56,2	10	1"	1"	10_B
DCS502A	38,05	32,45	15729	12365	6,6	5,65	40,21	30,36	47	41			2 x 500	56,2	10	1"1/4	1"1/4	14_C
DCS502B	47,07	38,71	14687	11281	8,2	6,73	61,22	43,25	47	41			2 x 500	84,3	14	1"1/2	1"1/2	16_B
DCS502C	51,02	40,69	13759	10367	8,8	7,06	38,55	25,99	47	41			2 x 500	112,4	18	1"1/2	1"1/2	22_C
DCS503A	57,74	49,24	23593	18548	10,1	8,57	59,98	45,26	49	43			3 x 500	84,3	15	1"1/2	1"1/2	18_B
DCS503B	70,57	58,03	22031	16922	12,3	10,10	58,19	41,11	49	43			3 x 500	126,5	21	2"	2"	24_C
DCS503C	77,21	61,51	20638	15550	13,4	10,68	59,04	39,6	49	43			3 x 500	168,7	27	2"	2"	28_C
DCS504B	93,7	77,07	29375	22562	16,3	13,4	47,55	33,6	50	44			4 x 500	168,7	28	2"	2"	34_D
DCS504C	102,8	81,93	27517	20733	17,8	14,22	54,67	36,67	50	44	4 x 500	224,9	35	2"	2"	38_D		
DCL501A	14,82	11,7	5226	3750	2,58	2,04	75,68	50,16	35	30	P=320W I=0.74A n=900min-1	P=200W I=0.41A n=640min-1	1 x 500	28,1	6	1"	1"	5_A
DCL501B	17,3	13,02	4866	3405	3,01	2,25	40,65	24,41	35	30			1 x 500	42,2	8	1"	1"	8_B
DCL501C	18,35	13,36	4542	3130	3,18	2,32	32,37	18,49	35	30			1 x 500	56,2	10	1"	1"	10_B
DCL502A	29,44	23,25	10451	7500	5,12	4,06	50,03	33,2	38	33			2 x 500	56,2	10	1"1/4	1"1/4	11_B
DCL502B	34,84	26,21	9732	6810	6,08	4,55	52,34	31,44	38	33			2 x 500	84,3	14	1"1/2	1"1/2	14_A
DCL502C	37,01	26,92	9084	6260	6,42	4,67	53,32	30,42	38	33			2 x 500	112,4	18	1"1/2	1"1/2	16_A
DCL503A	43,87	34,66	15677	11251	7,636	6,05	36,92	24,53	40	35			3 x 500	84,3	15	1"1/2	1"1/2	18_B
DCL503B	52,11	39,18	14597	10215	9,1	6,78	43,57	25,93	40	35			3 x 500	126,5	21	2"	2"	22_B
DCL503C	55,32	40,25	13626	9390	9,6	6,98	40,36	23,04	40	35			3 x 500	168,7	27	2"	2"	26_B
DCL504B	69,87	52,57	19463	13620	12,19	9,13	59,89	35,99	41	36			4 x 500	168,7	28	2"	2"	26_B
DCL504C	73,99	53,81	18168	12519	12,84	9,33	49,4	28,19	41	36	4 x 500	224,9	35	2"	2"	32_B		
DCQ501A	11,75	9,98	3773	3028	2,051	1,74	50,55	37,79	29	25	P=140W I=0.33A n=670min-1	P=90W I=0.17A n=520min-1	1 x 500	28,1	6	1"	1"	5_A
DCQ501B	13,43	11,07	3477	2750	2,33	1,92	57,7	41,01	29	25			1 x 500	42,2	8	1"	1"	6_A
DCQ501C	13,81	11,14	3220	2525	2,39	1,93	36,44	24,98	29	25			1 x 500	56,2	10	1"	1"	8_A
DCQ502A	23,61	20,04	7545	6057	4,12	3,49	59,57	44,52	32	28			2 x 500	56,2	10	1"1/4	1"1/4	9_A
DCQ502B	26,64	21,98	6954	5501	4,60	3,81	32,13	23,04	32	28			2 x 500	84,3	14	1"1/2	1"1/2	14_A
DCQ502C	27,59	22,27	6440	5050	4,79	3,86	31,78	21,79	32	28			2 x 500	112,4	18	1"1/2	1"1/2	16_A
DCQ503A	35,33	29,99	11318	9085	6,16	5,23	51,02	38,14	34	30			3 x 500	84,3	15	1"1/2	1"1/2	14_A
DCQ503B	40,24	33,16	10431	8251	6,99	5,76	47,84	34	34	30			3 x 500	126,5	21	2"	2"	18_A
DCQ503C	41,62	33,57	9661	7575	7,22	5,82	50,66	34,71	34	30			3 x 500	168,7	27	2"	2"	20_A
DCQ504B	53,65	44,21	13907	11002	9,32	7,67	46,61	33,13	35	31			4 x 500	168,7	28	2"	2"	24_A
DCQ504C	55,16	44,52	12881	10100	9,57	7,72	29,44	20,19	35	31	4 x 500	224,9	35	2"	2"	32_B		

Nominal capacities according to standard EN1048 (water Tair=25°C, Tin=40°C, Tout=35°C).

*See the General Contents for more details.

DC - Single Fan Row

Drawings

Model	Dimensions			Weight	N° feet
	mm	mm	mm		
	A	B	C	Kg	
DCS501A	1142	940	-	56	4
DCS501B	1142	940	-	61	4
DCS501C	1142	940	-	67	4
DCS502A	2042	1840	-	97	4
DCS502B	2042	1840	-	106	4
DCS502C	2042	1840	-	115	4
DCS503A	2942	2740	-	134	4
DCS503B	2942	2740	-	151	4
DCS503C	2942	2740	-	165	4
DCS504B	3842	3640	1800	204	6
DCS504C	3842	3640	1800	223	6
DCL501A	1142	940	-	56	4
DCL501B	1142	940	-	61	4
DCL501C	1142	940	-	67	4
DCL502A	2042	1840	-	97	4
DCL502B	2042	1840	-	106	4
DCL502C	2042	1840	-	115	4
DCL503A	2942	2740	-	134	4
DCL503B	2942	2740	-	151	4
DCL503C	2942	2740	-	165	4
DCL504B	3842	3640	1800	204	6
DCL504C	3842	3640	1800	223	6
DCQ501A	1142	940	-	56	4
DCQ501B	1142	940	-	61	4
DCQ501C	1142	940	-	67	4
DCQ502A	2042	1840	-	97	4
DCQ502B	2042	1840	-	106	4
DCQ502C	2042	1840	-	115	4
DCQ503A	2942	2740	-	134	4
DCQ503B	2942	2740	-	151	4
DCQ503C	2942	2740	-	165	4
DCQ504B	3842	3640	1800	204	6
DCQ504C	3842	3640	1800	223	6

We reserve the right to change our technical data without prior notice.

Ø 500

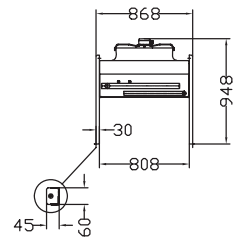
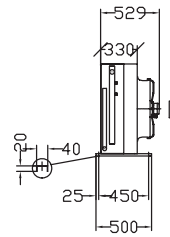
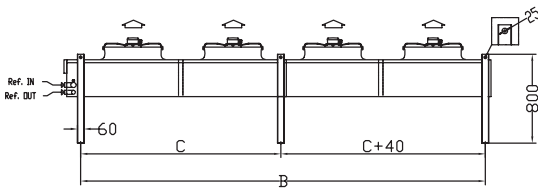
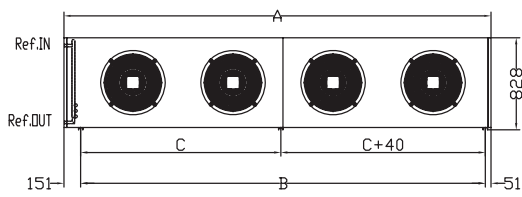
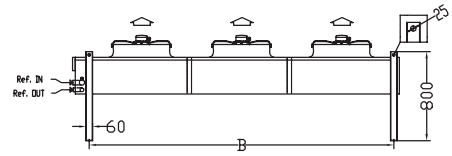
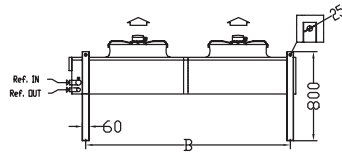
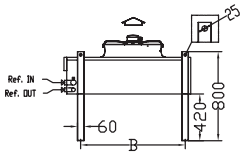
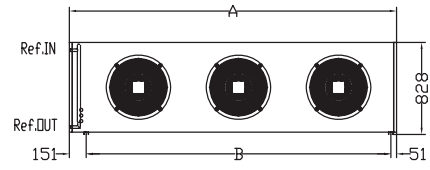
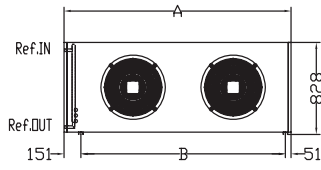
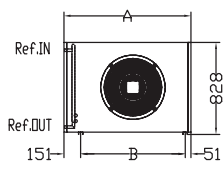

DC - Single Fan Row

Options

Motor fans



(a) Fan motor 400 V/3ph - 60Hz, IP54: S/Q/R
 (b) Fan motor 460 V/3ph - 60Hz, IP54: S/Q/R
 (c) Fan motor 230V/1ph - 50/60Hz, IP54: S/L/Q

Model:
All Models

Local safety switch wired

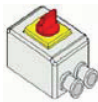

Local safety switch and cabling for each electric fan motor. Plastic covering box, IP65, nominal current 16A – 3 phases, insulated voltage 600V. Material / Colour: Polycarbonate grey (yellow-red handle)
 Mechanical duration: 20,000 operations. Operating temperature: -10°C, + 50°C Reference and standard CE/UL/CSA. Per unit.

Model:
All Models

Terminal Box

See Electrical Data Page.

Model:
All Models

Fan Speed Control

Fan speed controller equipment that checks and regulates the speed rotation of the fan's motor, keeping the temperature for dry coolers within the range or preset values. Constant control of the fan speed is achieved by variation of the electrical supply by phase-cut, as determined by the probe signal. The fan speed controller comes pre-connected to the switchboard. If you have different needs, please specify them when placing an order.
 Available for 230/1ph 50Hz and 400V/3ph 50Hz fan motor.

Model:
All Models

Coil Treatment / Material

Thermoguard for industrial or sea coast application.
 Aluminium fins pre-coated.
 Copper fins.
 Application Use: More information on corrosion prevention can be found in the Miscellaneous section.

Model:
All Models

Non-standard fin spacing

The standard fin spacing is 2.1mm.
 Alternative: 2.5mm and 3.2mm

Model:
All Models

Flanges AISI

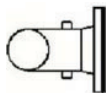

Model:
All Models

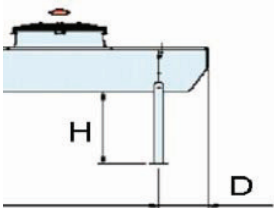
Feet															
	<table border="1"> <thead> <tr> <th>Model</th> <th>Ø</th> <th>H</th> <th>CODE</th> </tr> </thead> <tbody> <tr> <td>501-2-3</td> <td></td> <td>420 mm</td> <td>10999015</td> </tr> <tr> <td>504</td> <td></td> <td>420 mm</td> <td>10999016</td> </tr> </tbody> </table>	Model	Ø	H	CODE	501-2-3		420 mm	10999015	504		420 mm	10999016		Model: All Models
	Model	Ø	H	CODE											
	501-2-3		420 mm	10999015											
504		420 mm	10999016												

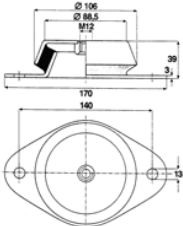
Vibration Dampers																					
	<table border="1"> <thead> <tr> <th>Type</th> <th>H mm</th> <th>A mm</th> <th>B mm</th> <th>C mm</th> <th>D mm</th> <th>Weight Kg</th> </tr> </thead> <tbody> <tr> <td>Single Row</td> <td>39</td> <td>140</td> <td>170</td> <td>M12</td> <td>13</td> <td>2</td> </tr> </tbody> </table>	Type	H mm	A mm	B mm	C mm	D mm	Weight Kg	Single Row	39	140	170	M12	13	2						Model: All Models
	Type	H mm	A mm	B mm	C mm	D mm	Weight Kg														
Single Row	39	140	170	M12	13	2															
Nuts and bolts are not included with these dampers.																					

DC - Single Fan Row

Electrical Data

Safety Switch

Function

Local safety switch and cabling for each electric fan motor.

General data

Power Supply:

- 400VAC, 50/60Hz
- Max fuse 16A

Number of poles: 3P

Cabinet Material: Plastic Case

Cabinet Colour: Grey (Yellow-Red Knob)

Protection Class: Min IP65

Ambient Temp.: min. -25°C, max. +50°C

Weight: Approx. 0.4Kg

Dimensions

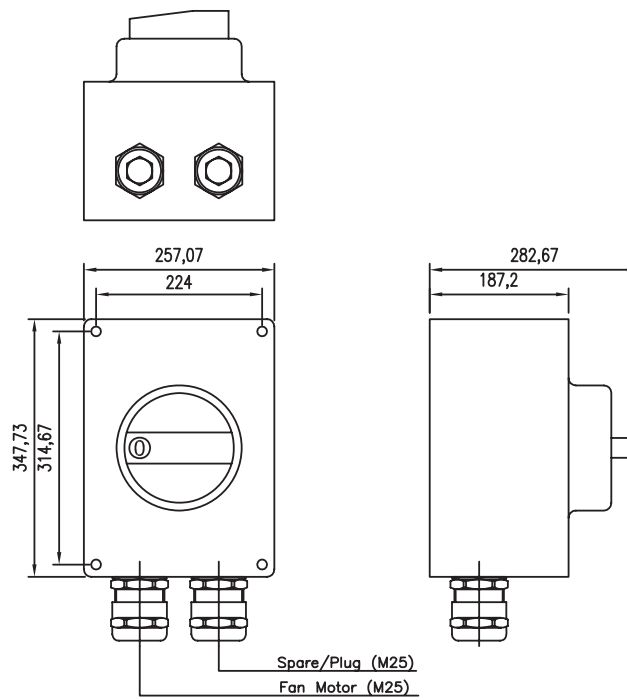

DC - Single Fan Row

Code description

Code No.

DC	1 S	2 50	3 2	4 A
----	--------	---------	--------	--------

1) Type of noise level (number of dB(A) to reduce compared with "base" version)

	Standard noise level	Low noise level	Quiet noise level	Residential noise level
	S*	L*	Q*	R*
Fan Ø 500 mm	std	-9	-19	-

2) Fan diameter Ø

50	500 mm
----	--------

3) Number of Fan (1-4)

4) Number of coil rows

A	2
B	3
C	4

General Alfa Select Air Legend

Description 1		Description 2	
D	D fan cabling (three phase)	BSFT	Basic Switch Board + Speed Control Temp. + Signal
Y	Y fan cabling (three phase)	BI	Basic Switch Board + Frequency Converter (Inverter)
D/Y	D/Y fan cabling (three phase), single speed fan motor	BSI	Basic Switch Board + Frequency Converter (Inverter) + Signal
S	Single phase	C	Switch Board + Cooling fan
P	Packaged on a pallet	R	Switch Board + Resistor
CR	Packaged in a crate	F	Switch Board + Cooling fan + Resistor
BO	Packaged in a box	PT	Ammonia pump top
Feet	Feet-mounted	PB	Ammonia pump bottom
SW	Safety Switch	AL	Aluminium casing
CB	Terminal Box	SS	Stainless Steel casing
B	Basic Switch Board	AP	Pre-painted Aluminium casing
BS	Basic Switch Board + Signal	PL	Plastic casing
BP	Basic Switch Board + Step Control Pressure	E	Electrical defrost
PT	Basic Switch Board + Step Control Temperature	LE	Low Electrical defrost
BSP	Basic Switch Board + Step Control Pressure + Signal	A	Air Defrost
BST	Basic Switch Board + Step Control Temp. + Signal	HG	Hot Gas Defrost
BFP	Basic Switch Board + Speed Control Pressure	HG+E	Hot Gas Defrost + Electrical Defrost on drip tray
BFT	Basic Switch Board + Speed Control Temperature	W	Water Defrost
BSFP	Basic Switch Board + Speed Control Pres. + Signal	W+E	Water Defrost + Electrical Defrost on drip tray
AL	Aluminium fin	CU	Copper fin
PR	Pre-coated fin	SS	Stainless steel tube
TH	Thermoguard treatment	CF	Cataphoresis treatment
SC	Sub-cooling circuit	KW	Spray water kit
FH	Fan ring heater	FL	Flanges
IS	Insulated Drip Tray	RH	Reheating coil
RH	Reheating coil	SR	Air socket adapter ring
CW	Air throw fan cowling	ER	120° elbow reducer
HN	Hinged fan cowling	HN	Hinged fan cowling

Note: valid for the entire product range

Alfa V- VDD/VDD6

General Contents

General Features

A dry cooler is a forced convection air-cooled fluid cooler, designed for outdoor installation. Air is forced over the finned coil which contains the working fluid such as a water and glycol mix. When determining the working fluid, consideration must be given to the lowest possible ambient temperature that could be experienced by the unit, in order to reduce the risk of freezing the working fluid. All products are designed to satisfy both commercial and industrial refrigeration, air conditioning, and retail refrigeration. Relative footprint, low consumption and low noise levels are the keys to this series' success.

Certifications and reliability

All Dry coolers are guaranteed by Eurovent "Certify All". Alfa Laval quality systems fully comply with ISO 9001, and all of our products are manufactured in strict accordance with CE regulations.

Capacity

The standard conditions stated in the catalogue are in accordance with EN 1048 (water, T_{air}= 25°C, T_{in}= 40°C, T_{out}= 35°C). All models have many circuiting options which can be selected to optimise duty with required fluid pressure drops and flow rates. Due to the multiple combinations of temperatures, flow rates and working fluids that can be encountered, it is not possible to display all the capacities in the catalogue.

How to determine the dry cooler's capacity:

Capacity required (e.g. 34%) = Nominal Capacity. (water) x 1.07 x F1 x F2

Altitude (m)	0	500	1000	1500	2000
F1	1	1,028	1,06	1,09	1,12

Fin material	Al	Al Prv	Cu
F2	1	1,03	0,97

Against Freezing

Given that the tubes are permanently in a horizontal position, it cannot be guaranteed that they drain completely when stoppages occur. As a result of this, a dry cooler containing water must be protected against freezing with an adequate amount of glycol.

Tube Protection

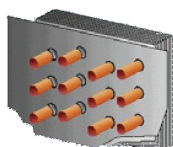

Due to the thermal expansion of the copper pipes, all metal sheets are equipped with an aluminium plate with collars. This plate supports the tube and therefore the pipes must not come into contact with the metal sheets. With this solution, the vibrations and thermal expansion are absorbed by the aluminium sheet. Leaks caused by friction cannot occur. The rigidity of the coil is sustained effectively.

Energy Efficiency Class

Energy efficiency class of air cooled condensers		
Class	Energy consumption	R
A	Extremely low	R>110
B	Very low	70≤R<110
C	Low	45≤R<70
D	Medium	30≤R<45
E	High	R<30

R = Condenser capacity (ΔT15K) / motor power consumption.

Test and cleaning

Coils are cleaned thoroughly in order to remove any traces of oil. Each heat exchanger undergoes a pressure and leak test with dry air at 10bar (PS= 9bar).



Sound Data

The sound pressure level is based on the calculation (according to EN 13487) of the sound pressure level on the surface of a cuboid area which is at a 10 metre distance and is parallel to the reference envelope of the sound source. (Standard sound pressure level; annex C EN 13487)

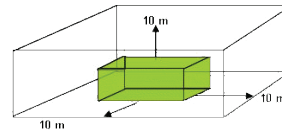

Sound pressure correction for distances other than 10 metres.

Distance (m)	2	3	4	5	7	10	15	20	30	40	50	60	80
Correction dB(A)	11	8,5	7	5	2,5	0	-3	-5,5	-9	-11	-12	-14	-16

Sound pressure level for several fans at nominal speed rating.

N° units	2	3	4	5	6	7	8	9	10
dB(A)	3	5	6	7	8	8,5	9	9,5	10

To calculate the sound pressure level, take the sound power of the individual fans according to their position, and calculate the sound propagation taking into consideration the local and ambient conditions. Speed change, start-up and control noises are not taken into account.

Fan Model	Speed rpm		Total Lw dB(A)		LW octave band spectrum dB(A)															
					63Hz		125Hz		250Hz		500Hz		1 000Hz		2 000Hz		4 000Hz		8 000Hz	
					Δ	Y	Δ	Y	Δ	Y	Δ	Y	Δ	Y	Δ	Y	Δ	Y	Δ	Y
800 S	880	660	83	76	-	-	69	56	67	62	74	69	78	74	79	72	72	64	62	54
800 L	680	530	76	71	-	-	57	49	62	57	69	63	74	68	72	63	65	55	55	45
800 Q	440	340	66	60	-	-	47	42	57	48	59	54	63	56	58	51	50	43	39	34
800 R	380	240	63	52	-	-	47	42	54	44	57	47	59	48	55	42	47	34	35	26
910 T	890	700	90	83	-	-	72	70	79	73	82	76	84	79	82	76	79	73	73	66
910 S	860	660	85	79	-	-	72	70	79	73	82	76	84	79	82	76	79	73	73	66
910 L	640	440	78	70	-	-	68	62	73	68	76	70	77	70	76	70	73	67	66	60
910 Q	440	330	68	62	-	-	57	49	61	58	64	57	67	60	61	53	52	45	43	35
910 R	390	250	65	53	-	-	56	46	59	45	59	46	61	49	56	44	48	35	38	22
1000 L	680	550	86	81	-	-	58	53	68	60	70	63	73	68	75	67	71	62	62	53
1000 Q	425	325	72	65	-	-	50	45	58	50	62	54	65	58	60	50	54	42	44	30
1000 R	390	260	70	61	-	-	50	44	56	45	60	49	64	52	55	44	48	36	37	25

Guarantee

All our products are protected under warranty for 18 months from the shipping date. If a defect should occur within the warranty period, please return the equipment or part to our factory free of charge where we will repair or replace the goods, depending on what is required. Unfortunately, We cannot take responsibility for damage caused by the misuse or incorrect installation of our products. Brochure subject to technical changes without prior notice



We recommend that you use the Alfa Select Air software for a precise thermal and mechanical design.



Alfa V- VDD/VDD6

Product description

Application

Refrigeration and air conditioning applications:

- water cooling
- free cooling

Standard design

Coil

Optimized "V-type" design provides large capacity within a compact size. This innovative heat exchanger design gives excellent heat transfer with minimal refrigerant costs, thanks to the new fin corrugation developed by Alfa Laval, combined with two different tube sizes 1/2" (VDD series) and 5/8" (VDD6 series). In the standard execution, heat exchanger manufactured from copper tubes and aluminium fins with spacing 2.1 mm. Double connection provides opportunity for two completely independent heat exchangers. Each heat exchanger undergoes a pressure and leak test with dry air at 11 bar, before being supplied with a nitrogen pre-charge.

Casing

The casework is made with painted galvanized steel sheets (corrosion resistance class C4) with an epoxy finish, RAL 9002. The new frame design provides greater rigidity also making it an ideal choice for heavy applications. The new system completely protects the heat exchanger tubes during transit and helps prevent problems caused by vibration and thermal expansion. Support made of galvanized steel.

Benefits

- Footprint
 - Optimises footprint with higher capacity 800, 910 and 1000mm fan.
 - More performance available
 - Low power consumption fan motor
 - More noise level options
 - Flexible design
- All parts are painted in accordance with RAL 9002
 - No cut edges
 - Higher corrosion resistance class (C4)
- Coil design
 - Increased heat transfer thanks to innovative fin corrugation
- Casing
 - Strong casing with new design
- High energy efficiency
 - Best performance with low energy consumption



Options

- Non-standard fin spacing
 - For dusty environments
- Coil treatment
 - Corrosion resistance
 - Suitable for aggressive environments
- Spray water device
 - Smaller units can be selected.
 - maintains performance during outside temperature peaks.
- Vibration dampers
 - Designed to reduce vibrations
- Special fans
 - EC fans
 - Best alternative for frequency converter control 480/3ph-60Hz, IP54
 - High adaptability on every market, IP55
 - High protection fan for use in tropical or desert areas
- Electrical parts

- Switch on/off
- Local safety switch wired to isolate the fan. An EMC switch is also available
- Terminal box
 - All fans are wired for easy connection to the electrical supply
- Switchboard
 - Build reliability
 - Corrosion / Shock / Condensation / UV-resistant
 - Wide range of solutions
 - IP66 for casing, IP56 for switchboard
 - 100% recyclable
- Cabling
 - Ready for installation
- Design for frequency converter
 - Units can run under frequency control (when air temperature falls below the designated level, it triggers energy saving, noise reduction and enables longer fan motor life)
- Fan step control
 - Energy saving
 - Cheapest method of controlling performance
- Fan speed control
 - Energy saving
 - Noise reduction when air temperature is below designated level.
 - Variable and efficient control of velocity according to heat reject.
 - Better performance control

Fans

Three different fan diameters available: 800, 910 and 1000mm with a 400V-50Hz three-phase motor. The motors come with external rotors, made in accordance with VDE 0530/12.84, IP54. These Axial Dry Coolers are available in 5 fan motor noise levels: (S) standard, (L) low, (Q) quiet, (R) residential and the new (T) high performance fan Axial Dry Coolers VDD/VDD6 800 and 910 are available in 4 fan motor noise levels: (S) standard, (L) low, (Q) quiet and (R) residential. Axial Dry Coolers VDD/VDD6 1000 are available in 3 fan motor noise levels: (L) low, (Q) quiet and (R) residential. New bell mouths optimise the performance of the fan motors and minimise the noise level. The fans are suitable for operation in air temperatures between -40°C and +40°C.

Each fan chamber is separated by internal baffle plates which enable optimal capacity control by separate running of the fans.

For air temperatures lower than +20°C, the full load current (FLC) can be calculated using the correction factor table. The overload protection should have a 20% margin to accommodate fan motor supplier variations.

T [°C]	20	10	0	-10	-15	-20	-25	-30
Fc	1	1,04	1,08	1,12	1,14	1,16	1,18	1,2

Model	Capacity		Airflow		Fluid flow		Pressure drop fluid		Lp [dB(A)]*		Motor (3/400V-50Hz)		E.E.C.**		Fans	Surface	Tube volume	Conn.			
	kW		m³/h		m³/h		kPa		(10m)		Δ	Y	Δ	Y	N° x D [mm]	m²	dm³	mm			
	Δ	Y	Δ	Y	Δ	Y	Δ	Y	Δ	Y								Inlet	Outlet		
VDDS802A	222,3	193,2	88780	70005	38,7	33,6	71,9	56,1	56	51	P=2000W I=4A n=880 min-1	P=1250W I=2,3A n=660 min-1	D	D	4 x 800	636,5	55,4	2xDN80	2xDN80		
VDDS802B	273,9	231,5	86052	67181	47,6	40,3	30,7	22,7	56	51			D	C	4 x 800	954,68	83,2	2xDN80	2xDN80		
VDDS802C	310,9	256,2	83370	64494	54,1	44,6	51,0	36,3	56	51			D	C	4 x 800	1272,86	110,9	2xDN80	2xDN80		
VDDS803A	333,2	289,6	133258	105100	57,9	50,4	58,2	45,4	58	53			D	D	6 x 800	960,92	83,7	2xDN80	2xDN80		
VDDS803B	415,0	350,5	129210	100907	72,2	61,0	42,0	31,1	58	53			D	C	6 x 800	1441,24	125,5	2xDN80	2xDN80		
VDDS803C	469,9	387,1	125227	96911	81,7	67,3	69,5	49,5	58	53			D	C	6 x 800	1921,70	167,4	2xDN100	2xDN100		
VDDS804A	448,0	389,2	177736	140195	77,9	67,7	80,2	62,6	59	54			D	D	8 x 800	1285,33	111,9	2xDN100	2xDN100		
VDDS804B	557,0	470,4	172368	134632	96,9	81,8	55,1	40,8	59	54			D	C	8 x 800	1927,93	167,9	2xDN100	2xDN100		
VDDS804C	627,4	516,9	167083	129327	109,1	89,9	68,6	48,9	59	54			D	C	8 x 800	2570,53	223,9	2xDN100	2xDN100		
VDDS805A	560,1	486,6	222214	175290	97,4	84,6	77,2	60,3	60	55			D	D	10 x 800	1609,61	140,2	2xDN100	2xDN100		
VDDS805B	697,1	588,7	215525	168356	121,2	102,4	55,7	41,3	60	55			D	C	10 x 800	2414,49	210,3	2xDN100	2xDN100		
VDDS805C	787,1	648,4	208939	161742	136,9	112,8	84,9	60,5	60	55			D	C	10 x 800	3219,36	280,4	2xDN100	2xDN100		
VDDS806A	648,4	563,9	266691	210384	112,8	98,1	17,4	13,6	61	56			D	D	12 x 800	1934,03	168,5	2xDN100	2xDN100		
VDDS806B	809,2	684,3	258681	202080	140,7	119,0	12,6	9,3	61	56			D	C	12 x 800	2901,18	252,7	2xDN100	2xDN100		
VDDS806C	942,2	776,3	250794	194157	163,9	135,0	67,7	48,2	61	56			D	C	12 x 800	3868,20	336,9	4xDN100	4xDN100		
VDDS807A	766,6	666,5	311169	245479	133,3	115,9	27,2	21,2	61	56			D	D	14 x 800	2258,45	196,7	4xDN100	4xDN100		
VDDS807B	955,7	807,9	301838	235804	166,2	140,5	19,7	14,6	61	56			D	C	14 x 800	3387,74	295,1	4xDN100	4xDN100		
VDDS807C	1069,9	882,7	292649	226572	186,1	153,5	14,4	10,2	61	56			D	C	14 x 800	4517,03	393,4	4xDN100	4xDN100		
VDDS808A	885,0	769,2	355646	280573	153,9	133,8	40,0	31,2	62	57			D	D	16 x 800	2582,86	225,0	4xDN100	4xDN100		
VDDS808B	1102,4	931,6	344995	269528	191,7	162,0	28,9	21,4	62	57			D	C	16 x 800	3874,43	337,5	4xDN100	4xDN100		
VDDS808C	1233,5	1017,0	334504	258986	214,5	176,9	21,2	15,0	62	57			D	C	16 x 800	5165,86	450	4xDN100	4xDN100		
VDDL802A	190,3	168,7	68290	56374	33,1	29,3	54,6	44,1	49	45			P=1050W I=2,4A n=680 min-1	P=770W I=1,5A n=530 min-1	C	C	4 x 800	636,5	55,4	2xDN80	2xDN80
VDDL802B	232,4	200,3	66270	54028	40,4	34,8	46,0	35,2	49	45					C	B	4 x 800	954,68	83,2	2xDN80	2xDN80
VDDL802C	255,5	215,3	64253	51823	44,4	37,4	36,1	26,7	49	45					C	B	4 x 800	1272,86	110,9	2xDN80	2xDN80
VDDL803A	285,2	252,8	102500	84640	49,6	44,0	44,2	35,7	51	47	C	C			6 x 800	960,92	83,7	2xDN80	2xDN80		
VDDL803B	351,8	303,4	99504	81153	61,2	52,8	69,7	53,5	51	47	C	B			6 x 800	1441,24	125,5	2xDN80	2xDN80		
VDDL803C	385,9	325,2	96510	77874	67,1	56,6	49,2	36,4	51	47	C	B			6 x 800	1921,70	167,4	2xDN100	2xDN100		
VDDL804A	383,2	339,9	136710	112904	66,6	59,1	60,9	49,6	52	48	C	C			8 x 800	1285,33	111,9	2xDN100	2xDN100		
VDDL804B	465,7	401,6	132737	108278	81,0	69,8	40,0	30,6	52	48	C	B			8 x 800	1927,93	167,9	2xDN100	2xDN100		
VDDL804C	515,1	434,2	128765	103923	89,6	75,5	48,6	35,9	52	48	C	B			8 x 800	2570,53	223,9	2xDN100	2xDN100		
VDDL805A	479,2	425,0	170919	141169	83,3	73,9	58,6	47,8	53	49	C	C			10 x 800	1609,61	140,2	2xDN100	2xDN100		
VDDL805B	582,8	502,4	165970	135402	101,3	87,4	40,5	30,9	53	49	C	B			10 x 800	2414,49	210,3	2xDN100	2xDN100		
VDDL805C	646,1	544,5	161021	129972	112,4	94,7	60,1	44,5	53	49	C	B			10 x 800	3219,36	280,4	2xDN100	2xDN100		
VDDL806A	555,3	492,6	205128	169433	96,6	85,7	13,2	10,7	54	50	C	C			12 x 800	1934,03	168,5	2xDN100	2xDN100		
VDDL806B	705,4	608,2	199203	162526	122,7	105,8	67,8	52,0	54	50	C	B			12 x 800	2901,18	252,7	2xDN100	2xDN100		
VDDL806C	773,6	652,1	193276	156021	134,5	113,4	47,9	35,5	54	50	C	B			12 x 800	3868,20	336,9	4xDN100	4xDN100		
VDDL807A	656,3	582,0	239338	197698	114,1	101,2	20,7	16,7	54	50	C	C			14 x 800	2258,45	196,7	4xDN100	4xDN100		
VDDL807B	799,8	690,9	232436	189650	139,1	120,2	14,3	11,1	54	50	C	B			14 x 800	3387,74	295,1	4xDN100	4xDN100		
VDDL807C	907,6	764,8	225531	182069	157,8	133,0	73,9	54,7	54	50	C	B			14 x 800	4517,03	393,4	4xDN100	4xDN100		
VDDL808A	757,3	671,5	273547	225962	131,7	116,8	30,4	24,6	55	51	C	C			16 x 800	2582,86	225	4xDN100	4xDN100		
VDDL808B	922,1	796,2	265668	216773	160,4	138,5	21,1	16,2	55	51	C	B			16 x 800	3874,43	337,5	4xDN100	4xDN100		
VDDL808C	1013,3	855,3	257785	208118	176,2	148,7	14,9	11,1	55	51	C	B			16 x 800	5165,86	450,0	4xDN100	4xDN100		
VDDQ802A	139,7	117,4	42475	33269	24,3	20,4	31,8	23,3	40	33	P=370W I=1,2A n=440 min-1	P=200W I=0,5A n=340 min-1			B	A	4 x 800	636,5	55,4	2xDN80	2xDN80
VDDQ802B	162,3	132,0	40981	31688	28,3	23,0	24,4	16,9	40	33					A	A	4 x 800	954,68	83,2	2xDN80	2xDN80
VDDQ802C	171,8	136,2	39509	30253	29,9	23,7	18,0	11,9	40	33					A	A	4 x 800	1272,86	110,9	2xDN80	2xDN80
VDDQ803A	212,2	178,4	63761	49957	37,0	31,1	58,5	43,3	42	35			B	A	6 x 800	960,92	83,7	2xDN80	2xDN80		
VDDQ803B	245,5	199,5	61545	47605	42,8	34,8	36,9	25,6	42	35			A	A	6 x 800	1441,24	125,5	2xDN80	2xDN80		
VDDQ803C	259,3	205,5	59357	45469	45,2	35,8	24,4	16,2	42	35			A	A	6 x 800	1921,70	167,4	2xDN100	2xDN100		
VDDQ804A	281,1	236,2	85046	66645	49,0	41,1	35,4	26,0	43	36			B	A	8 x 800	1285,33	111,9	2xDN100	2xDN100		
VDDQ804B	327,7	266,3	82108	63522	57,1	46,4	36,4	25,2	43	36			A	A	8 x 800	1927,93	167,9	2xDN100	2xDN100		
VDDQ804C	348,7	276,2	79206	60684	60,8	48,1	54,3	36,0	43	36			A	A	8 x 800	2570,53	223,9	2xDN100	2xDN100		
VDDQ805A	351,4	295,3	106331	83332	61,2	51,4	34,0	25,0	44	37			B	A	10 x 800	1609,61	140,2	2xDN100	2xDN100		
VDDQ805B	410,4	333,5	102671	79439	71,5	58,1	39,7	27,5	44	37			A	A	10 x 800	2414,49	210,3	2xDN100	2xDN100		
VDDQ805C	435,5	345,0	99053	75899	75,9	60,1	44,9	29,8	44	37			A	A	10 x 800	3219,36	280,4	2xDN100	2xDN100		
VDDQ806A	425,4	357,6	127617	100020	74,1	62,3	57,0	42,2	45	38			B	A	12 x 800	1934,03	168,5	2xDN100	2xDN100		
VDDQ806B	495,6	402,6	123234	95356	86,3	70,1	66,2	45,9	45	38			A	A	12 x 800	2901,18	252,7	2xDN100	2xDN100		
VDDQ806C	525,0	415,7	118901	91114	91,5	72,4	74,6	49,5	45	38			A	A	12 x 800	3868,20	336,9	4xDN100	4xDN100		
VDDQ807A	499,4	419,6	148902	116707	87,0	73,1	88,0	65,0	45	38			B	A	14 x 800	2258,45	196,7	4xDN100	4xDN100		
VDDQ807B	577,2	469,0	143796	111272	100,6	81,7	55,3	38,4	45	38			A	A	14 x 800	3387,74	295,1	4xDN100	4xDN100		
VDDQ807C	609,1	482,7	138748	106329	106,1	84,1	36,6	24,3	45	38			A	A	14 x 800	4517,03	393,4	4xDN100	4xDN100		
VDDQ808A	555,9	467,5	170187	133395	96,9	81,4	17,7	13,0	46	39			B	A	16 x						

Model	Capacity		Airflow		Fluid flow		Pressure drop fluid		Lp [dB(A)]*		Motor (3/400V-50Hz)		E.E.C.**		Fans	Surface	Tube volume	Conn.	
	kW		m³/h		m³/h		kPa		(10m)		Δ	Y	Δ	Y	N° x D [mm]	m²	dm³	mm	
	Δ	Y	Δ	Y	Δ	Y	Δ	Y	Δ	Y								Inlet	Outlet
VDDR802A	125,5	89,3	36495	23197	21,8	15,5	26,3	14,4	36	25	P=250W I=0,62A n=380 min ⁻¹	P=110W I=0,27A n=240 min ⁻¹	A	A	4 x 800	636,5	55,4	2xDN80	2xDN80
VDDR802B	143,2	96,7	35010	21950	24,9	16,8	19,5	9,8	36	25			A	A	4 x 800	954,68	83,2	2xDN80	2xDN80
VDDR802C	149,4	97,1	33598	20820	26,0	16,9	14,0	6,6	36	25			A	A	4 x 800	1272,86	110,9	2xDN80	2xDN80
VDDR803A	190,6	135,5	54791	34837	33,1	23,6	48,4	26,5	38	27			A	A	6 x 800	960,92	83,7	2xDN80	2xDN80
VDDR803B	216,5	146,0	52586	32984	37,6	25,4	29,5	14,8	38	27			A	A	6 x 800	1441,24	125,5	2xDN80	2xDN80
VDDR803C	227,0	147,2	50486	31300	39,5	25,6	43,0	20,1	38	27			A	A	6 x 800	1921,70	167,4	2xDN100	2xDN100
VDDR804A	254,5	180,9	73087	46477	44,3	31,5	47,8	26,1	39	28			A	A	8 x 800	1285,33	111,9	2xDN100	2xDN100
VDDR804B	288,9	194,9	70161	44017	50,3	33,9	29,1	14,6	39	28			A	A	8 x 800	1927,93	167,9	2xDN100	2xDN100
VDDR804C	303,0	196,5	67374	41779	52,7	34,2	42,4	19,8	39	28			A	A	8 x 800	2570,53	223,9	2xDN100	2xDN100
VDDR805A	318,9	226,7	91383	58117	55,5	39,4	54,8	30,0	40	29			A	A	10 x 800	1609,61	140,2	2xDN100	2xDN100
VDDR805B	363,9	245,2	87737	55050	63,3	42,6	54,3	27,1	40	29			A	A	10 x 800	2414,49	210,3	2xDN100	2xDN100
VDDR805C	378,5	245,6	84261	52259	65,8	42,7	35,1	16,4	40	29			A	A	10 x 800	3219,36	280,4	2xDN100	2xDN100
VDDR806A	382,1	271,6	109679	69757	66,5	47,2	47,1	25,7	41	30			A	A	12 x 800	1934,03	168,5	2xDN100	2xDN100
VDDR806B	436,8	294,3	105312	66083	76,0	51,2	53,0	26,4	41	30			A	A	12 x 800	2901,18	252,7	2xDN100	2xDN100
VDDR806C	456,1	295,6	101149	62738	79,3	51,4	58,2	27,2	41	30			A	A	12 x 800	3868,20	336,9	4xDN100	4xDN100
VDDR807A	448,6	318,7	127975	81397	78,0	55,4	72,7	39,7	41	30			A	A	14 x 800	2258,45	196,7	4xDN100	4xDN100
VDDR807B	508,8	343,0	122887	77115	88,5	59,6	44,3	22,1	41	30			A	A	14 x 800	3387,74	295,1	4xDN100	4xDN100
VDDR807C	532,3	345,1	118036	73217	92,6	60,0	59,5	27,8	41	30			A	A	14 x 800	4517,03	393,4	4xDN100	4xDN100
VDDR808A	499,7	355,6	146271	93037	86,9	61,8	14,6	8,0	42	31			A	A	16 x 800	2582,86	225	4xDN100	4xDN100
VDDR808B	583,8	393,3	140462	88148	101,5	68,4	64,4	32,1	42	31			A	A	16 x 800	3874,43	337,5	4xDN100	4xDN100
VDDR808C	607,0	393,7	134923	83696	105,6	68,5	41,6	19,4	42	31	A	A	16 x 800	5165,86	450,0	4xDN100	4xDN100		

Nominal capacities according to standard EN1048 (water Tair=25°C, Tin=40°C, Tout=35°C).

*See the General Contents for more details.

**Energy Efficiency Class: see "General Contents" for more details.

Model	Capacity		Airflow		Fluid flow		Pressure drop fluid		Lp [dB(A)]*		Motor (3/400V-50Hz)		E.E.C.**		Fans	Surface	Tube volume	Conn.	
	kW		m³/h		m³/h		kPa		(10m)		Δ		Δ	Y	N° x D [mm]	m²	dm³	mm	
	Δ	Y	Δ	Y	Δ	Y	Δ	Y	Δ	Y	Δ	Y	Δ	Y				Inlet	Outlet
VDDT902A	267,6	241,7	127573	105306	46,6	42,1	60,09	50,18	62	57			E	E	4 x 910	636,5	55,4	2xDN80	2xDN80
VDDT902B	342,9	302,0	123300	100215	59,7	52,6	45,4	36,26	62	57			E	D	4 x 910	954,68	83,2	2xDN80	2xDN80
VDDT902C	398,1	342,4	118519	95183	69,3	59,6	79,3	60,99	62	57			E	D	4 x 910	1272,86	110,9	2xDN80	2xDN80
VDDT903A	401,2	362,4	191483	158121	69,9	63,1	50,1	41,85	64	59			E	D	6 x 910	960,92	83,7	2xDN80	2xDN80
VDDT903B	520,0	458,2	185176	150573	90,6	79,8	62,3	50,19	64	59			E	D	6 x 910	1441,24	125,5	2xDN80	2xDN80
VDDT903C	593,7	511,1	178095	143093	103,4	89,0	47,5	36,64	64	59			E	D	6 x 910	1921,70	167,4	2xDN100	2xDN100
VDDT904A	537,9	485,9	255391	210933	93,7	84,6	57,9	48,37	65	60			E	D	8 x 910	1285,33	111,9	2xDN100	2xDN100
VDDT904B	689,2	607,0	247049	200929	120,1	105,7	43,7	34,95	65	60			D	D	8 x 910	1927,93	167,9	2xDN100	2xDN100
VDDT904C	798,9	687,3	237668	191002	139,2	119,7	70,7	54,36	65	60			E	D	8 x 910	2570,53	223,9	2xDN100	2xDN100
VDDT905A	645,3	583,3	319299	263745	112,4	101,6	14,4	12,02	66	61	P=3600W I=7,2A n=890 min-1		E	D	10 x 910	1609,61	140,2	2xDN100	2xDN100
VDDT905B	828,3	730,3	308922	251285	144,3	127,2	10,9	8,71	66	61			D	D	10 x 910	2414,49	210,3	2xDN100	2xDN100
VDDT905C	997,7	858,5	297240	238909	173,8	149,6	63,0	48,52	66	61			D	D	10 x 910	3219,36	280,4	2xDN100	2xDN100
VDDT906A	789,4	713,3	383207	316557	137,5	124,3	24,6	20,55	67	62			E	D	12 x 910	1934,03	168,5	2xDN100	2xDN100
VDDT906B	1012,4	892,2	370794	301640	176,4	155,4	18,6	14,87	67	62			E	D	12 x 910	2901,18	252,7	2xDN100	2xDN100
VDDT906C	1158,4	997,6	356811	286816	201,8	173,8	14,3	10,92	67	62			D	D	12 x 910	3868,20	336,9	4xDN100	4xDN100
VDDT907A	933,8	843,6	447114	369369	162,7	147,0	38,6	32,22	67	62			E	D	14 x 910	2258,45	196,7	4xDN100	4xDN100
VDDT907B	1196,8	1054,4	432666	351995	208,5	183,7	29,1	23,29	67	62			D	D	14 x 910	3387,74	295,1	4xDN100	4xDN100
VDDT907C	1368,2	1177,8	416383	334723	238,4	205,2	22,3	17,06	67	62			D	D	14 x 910	4517,03	393,4	4xDN100	4xDN100
VDDT908A	1078,4	974,1	511021	422180	187,9	169,7	56,8	47,43	68	63			E	D	16 x 910	2582,86	225,0	4xDN100	4xDN100
VDDT908B	1381,5	1216,8	494538	402349	240,7	212,0	42,9	34,27	68	63			D	D	16 x 910	3874,43	337,5	4xDN100	4xDN100
VDDT908C	1578,3	1358,1	475954	382629	275,0	236,6	32,7	25,06	68	63			D	C	16 x 910	5165,86	450,0	4xDN100	4xDN100
VDDS902A	221,0	192,0	89655	70571	38,4	33,4	42,8	33,4	58	53			D	C	4 x 910	636,5	55,4	2xDN80	2xDN80
VDDS902B	279,2	235,7	86693	67640	48,6	41,0	63,8	47,2	58	53			C	C	4 x 910	954,68	83,2	2xDN80	2xDN80
VDDS902C	311,9	257,2	83717	64812	54,2	44,7	51,3	36,6	58	53			C	C	4 x 910	1272,86	110,9	2xDN80	2xDN80
VDDS903A	335,1	291,0	134577	105952	58,3	50,6	58,8	45,8	60	55			D	C	6 x 910	960,92	83,7	2xDN80	2xDN80
VDDS903B	417,0	352,2	130186	101602	72,5	61,3	42,4	31,4	60	55			C	C	6 x 910	1441,24	125,5	2xDN80	2xDN80
VDDS903C	471,4	388,6	125767	97397	82,0	67,6	70,0	49,9	60	55			C	C	6 x 910	1921,70	167,4	2xDN100	2xDN100
VDDS904A	444,0	385,7	179499	141332	77,2	67,1	41,2	32,2	61	56			D	C	8 x 910	1285,33	111,9	2xDN100	2xDN100
VDDS904B	559,8	472,7	173678	135563	97,4	82,2	55,6	41,1	61	56			C	C	8 x 910	1927,93	167,9	2xDN100	2xDN100
VDDS904C	625,6	515,9	167816	129981	108,8	89,7	45,7	32,5	61	56			C	C	8 x 910	2570,53	223,9	2xDN100	2xDN100
VDDS905A	563,3	489,0	224420	176712	98,0	85,1	78,0	60,8	62	57	P=1650W I=3,5A n=860 min-1		D	C	10 x 910	1609,61	140,2	2xDN100	2xDN100
VDDS905B	700,6	591,5	217169	169524	121,8	102,9	56,2	41,6	62	57			C	C	10 x 910	2414,49	210,3	2xDN100	2xDN100
VDDS905C	781,3	644,4	209865	162564	135,9	112,1	40,8	29,0	62	57			C	C	10 x 910	3219,36	280,4	2xDN100	2xDN100
VDDS906A	652,1	566,7	269340	212092	113,4	98,6	17,5	13,7	63	58			D	C	12 x 910	1934,03	168,5	2xDN100	2xDN100
VDDS906B	812,4	687,7	260660	203484	141,3	119,6	12,6	9,4	63	58			C	C	12 x 910	2901,18	252,7	2xDN100	2xDN100
VDDS906C	945,4	779,4	251913	195147	164,4	135,5	68,1	48,6	63	58			C	C	12 x 910	3868,20	336,9	4xDN100	4xDN100
VDDS907A	770,9	669,8	314261	247472	134,1	116,5	27,5	21,4	63	58			D	C	14 x 910	2258,45	196,7	4xDN100	4xDN100
VDDS907B	960,6	811,8	304151	237444	167,1	141,2	19,9	14,7	63	58			C	C	14 x 910	3387,74	295,1	4xDN100	4xDN100
VDDS907C	1073,4	886,2	293961	227730	186,7	154,1	14,5	10,3	63	58			C	C	14 x 910	4517,03	393,4	4xDN100	4xDN100
VDDS908A	890,0	773,0	359182	282852	154,8	134,4	40,4	31,5	64	59			D	C	16 x 910	2582,86	225,0	4xDN100	4xDN100
VDDS908B	1108,0	936,1	347642	271404	192,7	162,8	29,2	21,6	64	59			C	C	16 x 910	3874,43	337,5	4xDN100	4xDN100
VDDS908C	1237,8	1021,0	336009	260313	215,3	177,6	21,4	15,1	64	59			C	C	16 x 910	5165,86	450,0	4xDN100	4xDN100
VDDL902A	187,3	149,8	66563	47056	32,6	26,1	53,1	35,96	51	44			C	B	4 x 910	636,5	55,4	2xDN80	2xDN80
VDDL902B	227,0	173,5	64138	44626	39,5	30,2	44,2	27,4	51	44			C	B	4 x 910	954,68	83,2	2xDN80	2xDN80
VDDL902C	248,0	182,8	61845	42515	43,1	31,8	34,3	20,0	51	44			B	B	4 x 910	1272,86	110,9	2xDN80	2xDN80
VDDL903A	280,7	224,6	99925	70669	48,8	39,1	43,0	29,13	53	46			C	B	6 x 910	960,92	83,7	2xDN80	2xDN80
VDDL903B	344,0	262,5	96323	67050	59,8	45,7	67,4	41,5	53	46			B	B	6 x 910	1441,24	125,5	2xDN80	2xDN80
VDDL903C	374,6	276,0	92912	63901	65,1	48,0	46,7	27,3	53	46			B	B	6 x 910	1921,70	167,4	2xDN100	2xDN100
VDDL904A	377,3	301,6	133286	94282	65,6	52,5	59,3	40,1	54	47			C	B	8 x 910	1285,33	111,9	2xDN100	2xDN100
VDDL904B	459,3	350,5	128507	89473	79,9	60,9	66,5	40,9	54	47			B	B	8 x 910	1927,93	167,9	2xDN100	2xDN100
VDDL904C	500,1	368,5	123979	85287	87,0	64,1	46,1	26,9	54	47			B	B	8 x 910	2570,53	223,9	2xDN100	2xDN100
VDDL905A	471,7	377,2	166647	117895	82,0	65,6	57,0	38,61	55	48	P=900W I=2,2A n=640 min-1		C	B	10 x 910	1609,61	140,2	2xDN100	2xDN100
VDDL905B	569,5	435,2	160691	111896	99,0	75,7	38,9	24,2	55	48			C	B	10 x 910	2414,49	210,3	2xDN100	2xDN100
VDDL905C	627,2	462,1	155045	106672	109,1	80,4	57,1	33,3	55	48			B	B	10 x 910	3219,36	280,4	2xDN100	2xDN100
VDDL906A	546,8	437,7	200008	141507	95,1	76,1	12,8	8,66	56	49			C	B	12 x 910	1934,03	168,5	2xDN100	2xDN100
VDDL906B	689,8	526,4	192874	134319	120,0	91,5	65,6	40,4	56	49			B	B	12 x 910	2901,18	252,7	2xDN100	2xDN100
VDDL906C	751,0	553,5	186111	128058	130,6	96,3	45,5	26,6	56	49			B	B	12 x 910	3868,20	336,9	4xDN100	4xDN100
VDDL907A	646,1	517,4	233369	165120	112,4	90,0	20,1	13,66	56	49			C	B	14 x 910	2258,45	196,7	4xDN100	4xDN100
VDDL907B	781,7	597,9	225057	156742	136,0	104,0	13,8	8,5	56	49			C	B	14 x 910	3387,74	295,1	4xDN100	4xDN100
VDDL907C	881,1	648,9	217176	149443	153,2	112,9	70,2	40,9	56	49			B	B	14 x 910	4517,03	393,4	4xDN100	4xDN100
VDDL908A	745,7	596,7	266730	188732	129,7	103,8	29,6	20,07	57	50			C	B	16 x 910	2582,86	225,0	4xDN100	4xDN100
VDDL908B	901,3	689,4	257240	179165	156,7	119,9	20,2	12,6	57	50			C	B	16 x 910	3874,43	337,5	4xDN100	4xDN100
VDDL908C	984,0	726,9	248242	170828	171,1	126,4	14,2	8,3	57	50			B	B	16 x 910	5165,86	450,0	4xDN100	4xDN100

Nominal capacities according to standard EN1048 (water Tair=25°C, Tin=40°C, Tout=35°C).

*See the General Contents for more details.

**Energy Efficiency Class: see "General Contents" for more details.

Model	Capacity		Airflow		Fluid flow		Pressure drop fluid		Lp [dB(A)]*		Motor (3/400V-50Hz)		E.E.C.**		Fans	Surface	Tube volume	Conn.	
	kW		m³/h		m³/h		kPa		(10m)		Δ		Δ		N° x D [mm]	m²	dm³	mm	
	Δ	Y	Δ	Y	Δ	Y	Δ	Y	Δ	Y	Δ	Y	Δ	Y				Inlet	Outlet
VDDQ902A	141,8	120,8	43412	34590	24,7	21,0	32,6	24,5	41	35	P=270W I=0.7A n=390 min-1	P=140W I=0.32A n=250 min-1	A	A	4 x 910	636,5	55,4	2xDN80	2xDN80
VDDQ902B	164,5	135,8	41691	32807	28,7	23,7	25,0	17,8	41	35			A	A	4 x 910	954,68	83,2	2xDN80	2xDN80
VDDQ902C	173,8	140,0	40047	31196	30,3	24,4	18,3	12,5	41	35			A	A	4 x 910	1272,86	110,9	2xDN80	2xDN80
VDDQ903A	215,4	183,4	65175	51945	37,5	32,0	60,2	45,2	43	37			A	A	6 x 910	960,92	83,7	2xDN80	2xDN80
VDDQ903B	248,9	205,3	62619	49293	43,4	35,8	37,7	26,9	43	37			A	A	6 x 910	1441,24	125,5	2xDN80	2xDN80
VDDQ903C	264,3	212,7	60175	46894	46,1	37,0	56,2	38,3	43	37			A	A	6 x 910	1921,70	167,4	2xDN100	2xDN100
VDDQ904A	287,6	244,9	86937	69301	50,1	42,7	59,4	44,6	44	38			A	A	8 x 910	1285,33	111,9	2xDN100	2xDN100
VDDQ904B	332,2	274,1	83546	65779	57,9	47,8	37,3	26,5	44	38			A	A	8 x 910	1927,93	167,9	2xDN100	2xDN100
VDDQ904C	352,9	283,9	80301	62591	61,5	49,5	55,4	37,8	44	38			A	A	8 x 910	2570,53	223,9	2xDN100	2xDN100
VDDQ905A	356,8	303,9	108700	86656	62,2	52,9	35,0	26,3	45	39			A	A	10 x 910	1609,61	140,2	2xDN100	2xDN100
VDDQ905B	418,6	345,2	104473	82264	72,9	60,1	69,5	49,5	45	39			A	A	10 x 910	2414,49	210,3	2xDN100	2xDN100
VDDQ905C	440,7	354,7	100428	78288	76,8	61,8	45,9	31,3	45	39			A	A	10 x 910	3219,36	280,4	2xDN100	2xDN100
VDDQ906A	431,9	367,7	130462	104011	75,2	64,1	58,6	44,0	46	40			A	A	12 x 910	1934,03	168,5	2xDN100	2xDN100
VDDQ906B	502,4	414,4	125400	98750	87,5	72,2	67,8	48,3	46	40			A	A	12 x 910	2901,18	252,7	2xDN100	2xDN100
VDDQ906C	529,6	426,2	120554	93984	92,3	74,2	50,6	34,6	46	40			A	A	12 x 910	3868,20	336,9	4xDN100	4xDN100
VDDQ907A	489,5	417,2	152224	121366	85,3	72,7	12,4	9,3	46	40			A	A	14 x 910	2258,45	196,7	4xDN100	4xDN100
VDDQ907B	585,2	482,7	146327	115235	102,0	84,1	56,7	40,4	46	40			A	A	14 x 910	3387,74	295,1	4xDN100	4xDN100
VDDQ907C	620,1	498,8	140681	109681	108,0	86,9	77,8	53,1	46	40			A	A	14 x 910	4517,03	393,4	4xDN100	4xDN100
VDDQ908A	564,5	481,0	173986	138721	98,3	83,8	18,2	13,7	47	41			A	A	16 x 910	2582,86	225,0	4xDN100	4xDN100
VDDQ908B	671,7	553,9	167254	131721	117,0	96,5	82,4	58,7	47	41			A	A	16 x 910	3874,43	337,5	4xDN100	4xDN100
VDDQ908C	706,9	568,9	160807	125378	123,2	99,1	54,3	37,1	47	41	A	A	16 x 910	5165,86	450,0	4xDN100	4xDN100		
VDDR902A	135,2	98,1	40531	26175	23,5	17,1	30,0	16,9	40	30	P=270W I=0.7A n=390 min-1	P=140W I=0.32A n=250 min-1	A	A	4 x 910	636,5	55,4	2xDN80	2xDN80
VDDR902B	155,5	107,0	38825	24688	27,0	18,6	22,6	11,7	40	30			A	A	4 x 910	954,68	83,2	2xDN80	2xDN80
VDDR902C	163,3	108,1	37219	23391	28,4	18,8	16,4	7,9	40	30			A	A	4 x 910	1272,86	110,9	2xDN80	2xDN80
VDDR903A	205,4	148,8	60853	39314	35,7	25,9	55,2	31,1	42	32			A	A	6 x 910	960,92	83,7	2xDN80	2xDN80
VDDR903B	237,1	162,8	58319	37100	41,2	28,3	69,6	35,9	42	32			A	A	6 x 910	1441,24	125,5	2xDN80	2xDN80
VDDR903C	248,2	163,9	55929	35166	43,2	28,5	50,3	24,2	42	32			A	A	6 x 910	1921,70	167,4	2xDN100	2xDN100
VDDR904A	274,2	198,7	81175	52453	47,7	34,5	54,5	30,7	43	33			A	A	8 x 910	1285,33	111,9	2xDN100	2xDN100
VDDR904B	314,0	215,8	77812	49511	54,6	37,5	33,7	17,4	43	33			A	A	8 x 910	1927,93	167,9	2xDN100	2xDN100
VDDR904C	328,9	217,6	74639	46940	57,2	37,8	22,0	10,7	43	33			A	A	8 x 910	2570,53	223,9	2xDN100	2xDN100
VDDR905A	340,2	246,7	101497	65592	59,2	42,9	32,1	18,1	44	34			A	A	10 x 910	1609,61	140,2	2xDN100	2xDN100
VDDR905B	393,3	270,3	97305	61922	68,4	47,0	36,8	19,0	44	34			A	A	10 x 910	2414,49	210,3	2xDN100	2xDN100
VDDR905C	413,8	273,5	93349	58714	72,0	47,6	41,0	19,8	44	34			A	A	10 x 910	3219,36	280,4	2xDN100	2xDN100
VDDR906A	411,8	298,3	121818	78731	71,6	51,9	53,8	30,2	45	35			A	A	12 x 910	1934,03	168,5	2xDN100	2xDN100
VDDR906B	474,9	326,0	116797	74334	82,6	56,7	61,4	31,7	45	35			A	A	12 x 910	2901,18	252,7	2xDN100	2xDN100
VDDR906C	497,3	328,6	112058	70488	86,5	57,1	45,3	21,9	45	35			A	A	12 x 910	3868,20	336,9	4xDN100	4xDN100
VDDR907A	466,8	339,2	142140	91870	81,2	59,0	11,4	6,5	45	35			A	A	14 x 910	2258,45	196,7	4xDN100	4xDN100
VDDR907B	553,2	379,9	136290	86745	96,2	66,1	51,3	26,5	45	35			A	A	14 x 910	3387,74	295,1	4xDN100	4xDN100
VDDR907C	578,9	382,7	130767	82262	100,7	66,6	33,5	16,2	45	35			A	A	14 x 910	4517,03	393,4	4xDN100	4xDN100
VDDR908A	538,3	390,8	162461	105009	93,6	68,0	16,7	9,4	46	36			A	A	16 x 910	2582,86	225,0	4xDN100	4xDN100
VDDR908B	618,1	425,9	155783	99156	107,5	74,1	10,4	5,4	46	36			A	A	16 x 910	3874,43	337,5	4xDN100	4xDN100
VDDR908C	663,8	438,5	149477	94036	115,4	76,3	48,6	23,5	46	36	A	A	16 x 910	5165,86	450,0	4xDN100	4xDN100		

Nominal capacities according to standard EN1048 (water Tair=25°C, Tin=40°C, Tout=35°C).

*See the General Contents for more details.

**Energy Efficiency Class: see "General Contents" for more details.

Model	Capacity		Airflow		Fluid flow		Pressure drop fluid		Lp [dB(A)]*		Motor (3/400V-50Hz)		E.E.C.**		Fans	Surface	Tube volume	Conn.			
	kW		m³/h		m³/h		kPa		(10m)						N° x D [mm]	m²	dm³	mm			
	Δ	Y	Δ	Y	Δ	Y	Δ	Y	Δ	Y	Δ	Y	Δ	Y				Inlet	Outlet		
VDDL1002A	257,4	225,6	118412	92991	44,8	39,2	56,1	44,4	59	54	P=2200W I=4,2A n=670 min-1	P=1500W I=2,7A n=530min-1	D	D	4 x 1000	636,5	55,4	2xDN80	2xDN80		
VDDL1002B	320,6	273,4	110315	85797	55,8	47,5	40,3	30,6	59	54			D	C	4 x 1000	954,7	83,2	2xDN80	2xDN80		
VDDL1002C	361,8	300,5	103038	79628	62,9	52,3	66,9	47,9	59	54			C	C	4 x 1000	1273,0	110,9	2xDN80	2xDN80		
VDDL1003A	390,7	342,3	177890	139737	67,9	59,5	77,1	61,0	61	56			D	D	6 x 1000	960,9	83,7	2xDN80	2xDN80		
VDDL1003B	486,3	414,6	165851	129023	84,6	72,1	55,4	42,0	61	56			D	C	6 x 1000	1441,4	125,5	2xDN80	2xDN80		
VDDL1003C	540,1	448,9	155001	119814	93,9	78,1	40,2	28,8	61	56			C	C	6 x 1000	1921,9	167,4	2xDN100	2xDN100		
VDDL1004A	517,7	453,8	237366	186480	90,0	78,9	54,1	42,9	62	57			D	D	8 x 1000	1285,4	111,9	2xDN100	2xDN100		
VDDL1004B	1437,1	1195,2	414799	320725	249,9	209,9	27,7	19,9	62	57			B	B	8 x 1000	1928,0	167,9	2xDN100	2xDN100		
VDDL1004C	653,3	556,7	221385	172247	113,6	96,8	72,6	55,0	62	57			D	C	8 x 1000	2570,7	223,9	2xDN100	2xDN100		
VDDL1005A	726,8	603,8	206962	159997	126,4	105,0	59,7	42,8	63	58			D	D	10 x 1000	1609,8	140,2	2xDN100	2xDN100		
VDDL1005B	621,3	545,1	296840	233223	108,1	94,8	13,4	10,7	63	58			D	D	10 x 1000	2414,7	210,3	2xDN100	2xDN100		
VDDL1005C	817,9	696,9	276918	215471	142,2	121,2	73,6	55,7	63	58			D	C	10 x 1000	3219,6	280,4	2xDN100	2xDN100		
VDDL1006A	907,9	754,4	258922	200179	157,9	131,2	53,3	38,2	64	59			D	D	12 x 1000	1934,2	168,5	2xDN100	2xDN100		
VDDL1006B	760,0	666,5	356314	279966	132,2	115,9	23,0	18,2	64	59			D	D	12 x 1000	2901,4	252,7	2xDN100	2xDN100		
VDDL1006C	947,8	809,2	332450	258694	164,8	140,7	16,6	12,6	64	59			D	C	12 x 1000	3868,5	336,9	4xDN100	4xDN100		
VDDL1007A	1055,2	878,9	310881	240361	183,5	152,9	12,1	8,7	64	59			D	D	14 x 1000	2258,7	196,7	4xDN100	4xDN100		
VDDL1007B	899,0	788,1	415788	326708	156,3	137,1	36,1	28,6	64	59			D	D	14 x 1000	3388	295,1	4xDN100	4xDN100		
VDDL1007C	1120,4	955,9	387982	301916	194,8	166,2	25,9	19,7	64	59			D	C	14 x 1000	4517,4	393,4	4xDN100	4xDN100		
VDDL1008A	1246,0	1037,0	362840	280543	216,7	180,3	18,9	13,6	65	60			D	D	16 x 1000	2583,1	225,0	4xDN100	4xDN100		
VDDL1008B	1038,2	909,9	475262	373450	180,6	158,2	53,1	42,0	65	60			D	D	16 x 1000	3874,7	337,5	4xDN100	4xDN100		
VDDL1008C	1293,1	1102,7	443514	345139	224,9	191,8	38,2	29,0	65	60			D	C	16 x 1000	5166,2	450,0	4xDN100	4xDN100		
VDDQ1002A	204,6	167,3	76972	55589	35,6	29,1	62,0	43,8	45	38			P=860W I=2,0A n=420 min-1	P=500W I=0,97A n=310 min-1	C	B	4 x 1000	636,5	55,4	2xDN80	2xDN80
VDDQ1002B	240,2	186,3	70833	49847	41,8	32,5	24,3	15,4	45	38					B	B	4 x 1000	954,7	83,2	2xDN80	2xDN80
VDDQ1002C	257,1	193,0	64772	45347	44,8	33,6	36,5	22,0	45	38					B	B	4 x 1000	1273,0	110,9	2xDN80	2xDN80
VDDQ1003A	306,8	250,8	115664	83594	53,4	43,7	50,3	35,2	47	40	C	B			6 x 1000	960,9	83,7	2xDN80	2xDN80		
VDDQ1003B	369,2	285,9	106551	75018	64,3	49,8	75,9	48,0	47	40	B	B			6 x 1000	1441,4	125,5	2xDN80	2xDN80		
VDDQ1003C	389,1	291,8	97537	68283	67,8	50,8	50,0	30,1	47	40	B	B			6 x 1000	1921,9	167,4	2xDN100	2xDN100		
VDDQ1004A	412,5	337,4	154354	111598	71,9	58,8	69,3	49,0	48	41	C	B			8 x 1000	1285,4	111,9	2xDN100	2xDN100		
VDDQ1004B	493,2	381,9	140972	101922	85,8	66,4	75,0	47,4	48	41	B	B			8 x 1000	1928,0	167,9	2xDN100	2xDN100		
VDDQ1004C	519,9	389,9	130300	91217	90,6	67,9	49,4	29,7	48	41	B	B			8 x 1000	2570,7	223,9	2xDN100	2xDN100		
VDDQ1005A	515,8	422,0	193044	139602	89,9	73,5	66,8	47,2	49	42	B	B			10 x 1000	1609,8	140,2	2xDN100	2xDN100		
VDDQ1005B	612,0	474,4	177981	125360	106,6	82,6	44,2	28,0	49	42	B	B			10 x 1000	2414,7	210,3	2xDN100	2xDN100		
VDDQ1005C	652,5	489,2	163063	114151	113,7	85,2	61,2	36,8	49	42	B	B			10 x 1000	3219,6	280,4	2xDN100	2xDN100		
VDDQ1006A	597,6	489,2	231733	167605	104,1	85,2	15,0	10,6	50	43	B	B			12 x 1000	1934,2	168,5	2xDN100	2xDN100		
VDDQ1006B	741,1	574,0	213694	150530	129,1	100,0	74,1	46,8	50	43	B	B			12 x 1000	2901,4	252,7	2xDN100	2xDN100		
VDDQ1006C	781,5	586,1	195825	137084	136,1	102,1	48,8	29,4	50	43	B	B			12 x 1000	3868,5	336,9	4xDN100	4xDN100		
VDDQ1007A	706,4	578,0	270422	195608	123,1	100,7	23,5	16,5	50	43	B	B			14 x 1000	2258,7	196,7	4xDN100	4xDN100		
VDDQ1007B	840,1	652,0	249408	175700	146,4	113,6	15,7	9,9	50	43	B	B			14 x 1000	3388,0	295,1	4xDN100	4xDN100		
VDDQ1007C	888,7	668,4	228586	160018	154,8	116,5	10,4	6,3	50	43	B	B			14 x 1000	4517,4	393,4	4xDN100	4xDN100		
VDDQ1008A	815,4	667,0	309111	223611	142,1	116,2	34,6	24,3	51	44	B	B			16 x 1000	2583,1	225,0	4xDN100	4xDN100		
VDDQ1008B	968,9	751,9	285121	200869	168,8	131,0	23,0	14,6	51	44	B	B			16 x 1000	3874,7	337,5	4xDN100	4xDN100		
VDDQ1008C	1024,1	769,7	261348	182951	178,4	134,1	15,2	9,2	51	44	D	C			16 x 1000	5166,2	450,0	4xDN100	4xDN100		
VDDR1002A	190,1	142,1	68190	43533	33,1	24,7	54,5	32,7	43	34	P=670W I=1,4A n=380 min-1	P=330W I=0,67A n=250 min-1			B	B	4 x 1000	636,5	55,4	2xDN80	2xDN80
VDDR1002B	222,8	157,0	62393	39295	38,7	27,3	43,0	23,0	43	34					B	A	4 x 1000	954,7	83,2	2xDN80	2xDN80
VDDR1002C	231,7	157,3	56752	35640	40,3	27,3	30,4	15,4	43	34					B	A	4 x 1000	1273,0	110,9	2xDN80	2xDN80
VDDR1003A	285,1	213,1	102473	65450	49,6	37,1	44,2	26,5	45	36			B	B	6 x 1000	960,9	83,7	2xDN80	2xDN80		
VDDR1003B	333,0	235,1	93875	59136	57,9	40,9	28,4	15,3	45	36			B	A	6 x 1000	1441,4	125,5	2xDN80	2xDN80		
VDDR1003C	350,6	237,8	85475	53680	61,0	41,4	41,6	21,0	45	36			B	A	6 x 1000	1921,9	167,4	2xDN100	2xDN100		
VDDR1004A	383,3	286,3	136755	87365	66,7	49,8	60,9	36,5	46	37			B	A	8 x 1000	1285,4	111,9	2xDN100	2xDN100		
VDDR1004B	447,4	315,4	125355	78976	77,8	54,9	37,6	20,1	46	37			B	A	8 x 1000	1928,0	167,9	2xDN100	2xDN100		
VDDR1004C	468,5	317,7	114197	71718	81,5	55,3	41,1	20,7	46	37			B	A	8 x 1000	2570,7	223,9	2xDN100	2xDN100		
VDDR1005A	479,4	358,1	171036	109281	83,4	62,3	58,7	35,2	47	38			B	A	10 x 1000	1609,8	140,2	2xDN100	2xDN100		
VDDR1005B	560,1	394,8	156834	98815	97,4	68,7	38,0	20,3	47	38			B	A	10 x 1000	2414,7	210,3	2xDN100	2xDN100		
VDDR1005C	588,0	398,5	142918	89757	102,3	69,3	50,9	25,7	47	38			B	A	10 x 1000	3219,6	280,4	2xDN100	2xDN100		
VDDR1006A	555,6	416,2	205317	131196	96,6	72,4	13,2	8,0	48	39			B	B	12 x 1000	1934,2	168,5	2xDN100	2xDN100		
VDDR1006B	678,0	477,5	188313	118654	117,9	83,0	63,6	34,0	48	39			B	A	12 x 1000	2901,4	252,7	2xDN100	2xDN100		
VDDR1006C	704,3	477,6	171638	107795	122,5	83,1	40,6	20,5	48	39			B	A	12 x 1000	3868,5	336,9	4xDN100	4xDN100		
VDDR1007A	656,7	491,5	239598	153111	114,2	85,5	20,7	12,5	48	39			B	B	14 x 1000	2258,7	196,7	4xDN100	4xDN100		
VDDR1007B	768,7	543,4	219791	138493	133,7	94,5	13,4	7,2	48	39			B	A	14 x 1000	3388,0	295,1	4xDN100	4xDN100		
VDDR1007C	826,4	559,9	200358	125832	143,7	97,4	62,7	31,6	48	39			B	A	14 x 1000	4517,4	393,4	4xDN100	4xDN100		
VDDR1008A	757,9	566,8	273																		

Model	Capacity		Airflow		Fluid flow		Pressure drop fluid		Lp [dB(A)]*		Motor (3/400V-50Hz)		E.E.C.**		Fans	Surface	Tube volume	Conn.			
	kW		m³/h		m³/h		kPa		(10m)						N° x D [mm]	m²	dm³	mm			
	Δ	Y	Δ	Y	Δ	Y	Δ	Y	Δ	Y	Δ	Y	Δ	Y				Inlet	Outlet		
VDD6S802A	199,4	233,1	87993	63026	34,7	40,5	15,1	7,8	56	51	P=2000W I=4A n=880 min-1	P=1250W I=2,3A n=660 min-1	E	C	4 x 800	597,5	97,6	2xDN80	2xDN80		
VDD6S802B	251,9	171,5	84884	69182	43,8	29,8	13,4	11,5	56	51			D	D	4 x 800	895,5	146,6	2xDN80	2xDN80		
VDD6S802C	284,6	211,4	81868	66000	49,5	36,8	11,1	9,9	56	51			D	D	4 x 800	1194,1	195,4	2xDN80	2xDN80		
VDD6S803A	310,3	359,5	132092	94726	54,0	62,5	48,0	24,3	58	53			E	C	6 x 800	901,3	147,5	2xDN80	2xDN80		
VDD6S803B	390,8	266,7	127476	103879	68,0	46,4	42,9	36,7	58	53			D	D	6 x 800	1352,1	221,1	2xDN80	2xDN80		
VDD6S803C	440,0	327,1	122995	99152	76,5	56,9	35,2	31,2	58	53			D	C	6 x 800	1802,8	294,9	2xDN100	2xDN100		
VDD6S804A	408,7	472,1	176190	126424	71,1	82,1	27,9	10,5	59	54			E	C	8 x 800	1205,7	197,1	2xDN100	2xDN100		
VDD6S804B	522,8	358,5	170067	138575	90,9	62,3	47,0	49,1	59	54			D	D	8 x 800	1808,5	295,8	2xDN100	2xDN100		
VDD6S804C	587,4	437,7	164119	132302	102,1	76,1	34,7	34,2	59	54			D	C	8 x 800	2411,4	394,4	2xDN100	2xDN100		
VDD6S805A	513,3	593,5	220287	158122	89,3	103,2	32,1	13,1	60	55			E	C	10 x 800	1510,0	247,0	2xDN100	2xDN100		
VDD6S805B	651,5	446,7	212658	173271	113,3	77,7	38,7	40,5	60	55			D	D	10 x 800	2265,0	370,5	2xDN100	2xDN100		
VDD6S805C	732,2	545,5	205244	165451	127,3	94,9	28,7	28,2	60	55			D	C	10 x 800	3020,0	494,0	2xDN100	2xDN100		
VDD6S806A	613,7	709,0	264384	198919	106,7	123,3	27,5	10,4	61	56			E	C	12 x 800	1814,3	296,8	2xDN100	2xDN100		
VDD6S806B	781,8	536,6	255248	207966	136,0	93,3	37,7	41,5	61	56			D	D	12 x 800	2721,6	445,2	2xDN100	2xDN100		
VDD6S806C	880,8	654,6	246368	198601	153,2	113,8	31,7	27,5	61	56			D	C	12 x 800	3628,73	593,5	4xDN100	4xDN100		
VDD6S807A	724,8	835,4	308481	221516	126,1	145,3	42,9	16,1	61	56			E	C	14 x 800	2118,7	346,5	4xDN100	4xDN100		
VDD6S807B	907,9	623,0	297839	242662	157,9	108,3	31,2	32,8	61	56			D	D	14 x 800	3178,0	519,9	4xDN100	4xDN100		
VDD6S807C	1036,0	770,6	287492	231750	180,2	134,0	49,0	42,7	61	56			D	C	14 x 800	4237,4	693,1	4xDN100	4xDN100		
VDD6S808A	836,1	961,9	352578	253214	145,4	167,3	63,0	23,5	62	57			E	C	16 x 800	2423,0	396,4	4xDN100	4xDN100		
VDD6S808B	1047,5	718,4	340429	277358	182,2	124,9	46,0	48,2	62	57			D	D	16 x 800	3634,5	594,6	4xDN100	4xDN100		
VDD6S808C	1176,8	877,0	328616	264900	204,7	152,5	34,0	33,6	62	57			D	C	16 x 800	4846,0	792,8	4xDN100	4xDN100		
VDD6L802A	169,2	148,8	67712	56886	25,9	11776,0	11,3	9,0	49	45			P=1050W I=2,4A n=680 min-1	P=770W I=1,5A n=530 min-1	D	C	4 x 800	597,5	97,6	2xDN80	2xDN80
VDD6L802B	210,0	180,1	65395	53056	31,3	11373,0	9,8	7,4	49	45					C	C	4 x 800	895,5	146,6	2xDN80	2xDN80
VDD6L802C	233,4	196,0	63113	50628	34,1	10976,2	7,8	5,7	49	45					C	C	4 x 800	1194,1	195,4	2xDN80	2xDN80
VDD6L803A	263,0	231,2	101643	83618	40,2	17677,0	35,8	28,5	51	47	C	C			6 x 800	901,3	147,5	2xDN80	2xDN80		
VDD6L803B	324,9	278,4	98205	79708	48,4	17079,1	30,9	23,5	51	47	C	C			6 x 800	1352,1	221,1	2xDN80	2xDN80		
VDD6L803C	359,8	301,9	94816	76093	52,5	16489,7	24,4	18,0	51	47	C	B			6 x 800	1802,8	294,9	2xDN100	2xDN100		
VDD6L804A	353,5	310,7	135573	111549	54,0	23577,9	47,9	38,1	52	48	C	C			8 x 800	1205,7	197,1	2xDN100	2xDN100		
VDD6L804B	434,6	372,4	131015	106359	64,8	22785,2	33,8	25,7	52	48	C	C			8 x 800	1808,5	295,8	2xDN100	2xDN100		
VDD6L804C	486,4	408,0	126518	101558	71,0	22003,1	54,4	40,2	52	48	C	B			8 x 800	2411,4	394,4	2xDN100	2xDN100		
VDD6L805A	440,4	387,1	169504	139480	67,3	29479,0	39,5	31,4	53	49	C	C			10 x 800	1510,0	247,0	2xDN100	2xDN100		
VDD6L805B	541,6	464,2	163824	133010	80,7	28491,1	27,9	21,2	53	49	C	C			10 x 800	2265,0	370,5	2xDN100	2xDN100		
VDD6L805C	606,9	509,1	158220	127022	88,5	27516,5	45,0	33,2	53	49	C	B			10 x 800	3020,0	494,0	2xDN100	2xDN100		
VDD6L806A	529,0	465,0	203434	167410	80,9	35379,8	40,5	32,2	54	50	C	C			12 x 800	1814,3	296,8	2xDN100	2xDN100		
VDD6L806B	649,9	557,1	196633	159661	96,9	34197,0	27,2	20,7	54	50	C	C			12 x 800	2721,6	445,2	2xDN100	2xDN100		
VDD6L806C	725,3	608,7	189920	152485	105,9	33029,6	33,2	24,5	54	50	C	B			12 x 800	3628,73	593,5	4xDN100	4xDN100		
VDD6L807A	614,1	539,9	237364	195341	93,9	41280,7	32,0	25,5	54	50	C	C			14 x 800	2118,7	346,5	4xDN100	4xDN100		
VDD6L807B	765,0	655,6	229441	186311	114,0	39902,8	42,1	32,0	54	50	C	C			14 x 800	3178,0	519,9	4xDN100	4xDN100		
VDD6L807C	852,0	714,7	221622	177949	124,3	38543,0	51,2	37,8	54	50	C	B			14 x 800	4237,4	693,1	4xDN100	4xDN100		
VDD6L808A	708,2	622,4	271294	223271	108,3	47181,6	47,0	37,4	55	51	C	C			16 x 800	2423,0	396,4	4xDN100	4xDN100		
VDD6L808B	870,6	746,2	262250	212962	129,8	45608,7	33,1	25,2	55	51	C	C			16 x 800	3634,5	594,6	4xDN100	4xDN100		
VDD6L808C	973,5	816,7	253323	203413	142,0	44056,2	49,4	36,5	55	51	C	B			16 x 800	4846,0	792,8	4xDN100	4xDN100		
VDD6Q802A	122,8	102,7	42046	32798	17,9	7312,3	6,4	4,7	40	33	P=370W I=1,2A n=440 min-1	P=200W I=0,5A n=340 min-1			B	A	4 x 800	597,5	97,6	2xDN80	2xDN80
VDD6Q802B	146,2	118,5	40340	31050	20,6	7015,7	5,2	3,5	40	33					B	A	4 x 800	895,5	146,6	2xDN80	2xDN80
VDD6Q802C	157,1	124,6	38687	29492	21,7	6728,2	3,9	2,6	40	33					A	A	4 x 800	1194,1	195,4	2xDN80	2xDN80
VDD6Q803A	190,4	159,3	63125	49258	27,7	10978,8	20,3	14,9	42	35			B	A	6 x 800	901,3	147,5	2xDN80	2xDN80		
VDD6Q803B	225,4	182,8	60592	46656	31,8	10537,7	16,1	11,1	42	35			A	A	6 x 800	1352,1	221,1	2xDN80	2xDN80		
VDD6Q803C	241,5	191,4	58135	44333	33,3	10110,4	12,1	8,0	42	35			A	A	6 x 800	1802,8	294,9	2xDN100	2xDN100		
VDD6Q804A	258,4	215,8	84203	65717	37,5	14644,0	46,0	33,4	43	36			B	A	8 x 800	1205,7	197,1	2xDN100	2xDN100		
VDD6Q804B	304,8	247,1	80844	62262	43,0	14059,8	36,0	25	43	36			A	A	8 x 800	1808,5	295,8	2xDN100	2xDN100		
VDD6Q804C	326,0	258,1	77583	59175	44,9	13492,7	27,1	17,9	43	36			A	A	8 x 800	2411,4	394,4	2xDN100	2xDN100		
VDD6Q805A	323,8	270,5	105281	82175	47,0	18309,7	51,3	37,2	44	37			B	A	10 x 800	1510,0	247,0	2xDN100	2xDN100		
VDD6Q805B	380,8	308,7	101096	77867	53,7	17581,9	33,0	22,9	44	37			A	A	10 x 800	2265,0	370,5	2xDN100	2xDN100		
VDD6Q805C	410,5	324,8	97031	74015	56,5	16875,0	50,4	33,4	44	37			A	A	10 x 800	3020,0	494,0	2xDN100	2xDN100		
VDD6Q806A	386,8	323,1	126359	98634	56,2	21975,5	37,7	27,4	45	38			B	A	12 x 800	1814,3	296,8	2xDN100	2xDN100		
VDD6Q806B	460,3	373,0	121347	93472	64,9	21103,8	55,0	38,1	45	38			A	A	12 x 800	2721,6	445,2	2xDN100	2xDN100		
VDD6Q806C	491,4	388,9	116478	88856	67,6	20257,0	37,3	24,7	45	38			A	A	12 x 800	3628,73	593,5	4xDN100	4xDN100		
VDD6Q807A	451,0	376,8	147437	115092	65,5	25641,2	35,7	25,9	45	38			B	A	14 x 800	2118,7	346,5	4xDN100	4xDN100		
VDD6Q807B	534,6	433,4	141598	109077	75,4	24625,7	37,5	26,0	45	38			A	A	14 x 800	3178,0	519,9	4xDN100	4xDN100		
VDD6Q807C	571,0	452,1	135925	103697	78,6	23639,1	25,4	16,9	45	38			A	A	14 x 800	4237,4	693,1	4xDN100	4xDN100		

Model	Capacity		Airflow		Fluid flow		Pressure drop fluid		Lp [dB(A)]*		Motor (3/400V-50Hz)		E.E.C.**		Fans	Surface	Tube volume	Conn.	
	kW		m³/h		m³/h		kPa		(10m)		Δ Y		Δ Y	N° x D [mm]	m²	dm³	mm		
	Δ	Y	Δ	Y	Δ	Y	Δ	Y	Δ	Y	Δ	Y	Δ	Y			Inlet	Outlet	
VDD6R802A	110,0	78,2	36062	22827	13,6	6271,7	5,3	2,9	36	25	P=250W I=0.62A n=380 min-1	P=110W I=0.27A n=240 min-1	A	A	4 x 800	597,5	97,6	2xDN80	2xDN80
VDD6R802B	128,7	87,2	34389	21447	15,2	5980,7	4,1	2,1	36	25			A	A	4 x 800	895,5	146,6	2xDN80	2xDN80
VDD6R802C	136,7	89,3	32828	20223	15,5	5709,2	3,0	1,4	36	25			A	A	4 x 800	1194,1	195,4	2xDN80	2xDN80
VDD6R803A	170,7	121,0	54149	34288	21,0	9417,2	16,8	9,1	38	27			A	A	6 x 800	901,3	147,5	2xDN80	2xDN80
VDD6R803B	198,6	134,2	51663	32235	23,3	8984,9	12,9	6,5	38	27			A	A	6 x 800	1352,1	221,1	2xDN80	2xDN80
VDD6R803C	210,0	136,8	49339	30410	23,8	8580,7	9,5	4,4	38	27			A	A	6 x 800	1802,8	294,9	2xDN100	2xDN100
VDD6R804A	231,4	163,9	72235	45748	28,5	12562,6	37,8	20,6	39	28			A	A	8 x 800	1205,7	197,1	2xDN100	2xDN100
VDD6R804B	268,4	181,1	68937	43022	31,5	11989,0	28,9	14,4	39	28			A	A	8 x 800	1808,5	295,8	2xDN100	2xDN100
VDD6R804C	283,3	184,3	65850	40596	32,0	11452,2	21,1	9,9	39	28			A	A	8 x 800	2411,4	394,4	2xDN100	2xDN100
VDD6R805A	289,9	205,4	90321	57208	35,7	15708,0	42,1	23,0	40	29			A	A	10 x 800	1510,0	247,0	2xDN100	2xDN100
VDD6R805B	338,4	228,1	86210	53809	39,7	14993,0	53,9	26,9	40	29			A	A	10 x 800	2265,0	370,5	2xDN100	2xDN100
VDD6R805C	356,6	231,7	82361	50782	40,3	14323,7	39,4	18,4	40	29			A	A	10 x 800	3020,0	494,0	2xDN100	2xDN100
VDD6R806A	346,4	245,5	108407	68669	42,7	18853,4	31,0	16,9	41	30			A	A	12 x 800	1814,3	296,8	2xDN100	2xDN100
VDD6R806B	405,3	273,3	103483	64595	47,5	17997,0	44,1	22,0	41	30			A	A	12 x 800	2721,6	445,2	2xDN100	2xDN100
VDD6R806C	426,9	277,5	98871	60968	48,3	17195,0	29,1	13,6	41	30			A	A	12 x 800	3628,73	593,5	4xDN100	4xDN100
VDD6R807A	407,1	288,3	126493	80129	50,1	21998,8	47,9	26,1	41	30			A	A	14 x 800	2118,7	346,5	4xDN100	4xDN100
VDD6R807B	470,8	317,7	120756	75382	55,2	21001,0	30,1	15,0	41	30			A	A	14 x 800	3178,0	519,9	4xDN100	4xDN100
VDD6R807C	500,2	325,0	115382	71153	56,5	20066,4	44,7	20,9	41	30			A	A	14 x 800	4237,4	693,1	4xDN100	4xDN100
VDD6R808A	464,6	329,1	144579	91589	57,2	25144,2	42,8	23,4	42	31			A	A	16 x 800	2423,0	396,4	4xDN100	4xDN100
VDD6R808B	540,8	364,6	138029	86169	63,4	24005,0	43,8	21,9	42	31			A	A	16 x 800	3634,5	594,6	4xDN100	4xDN100
VDD6R808C	569,5	370,3	131892	81339	64,4	22937,7	28,9	13,5	42	31	A	A	16 x 800	4846,0	792,8	4xDN100	4xDN100		

Nominal capacities according to standard EN1048 (water Tair=25°C, Tin=40°C, Tout=35°C).

*See the General Contents for more details.

**Energy Efficiency Class: see "General Contents" for more details.

Model	Capacity		Airflow		Fluid flow		Pressure drop fluid		Lp [dB(A)]*		Motor (3/400V-50Hz)		E.E.C.**		Fans	Surface	Tube volume	Conn.			
	kW		m ³ /h		m ³ /h		kPa		(10m)		Δ	Y	Δ	Y	N° x D [mm]	m ²	dm ³	mm			
	Δ	Y	Δ	Y	Δ	Y	Δ	Y	Δ	Y								Inlet	Outlet		
VDD6T902A	246,4	311,2	126434	92431	42,9	54,1	21,8	13,02	62	57	P=3600W I=7,2A n=890 min-1	P=2500W I=4,2A n=700min-1	E	D	4 x 910	597,5	97,6	2xDN80	2xDN80		
VDD6T902B	318,5	220,3	121263	103863	55,4	38,3	20,3	17,96	62	57			E	E	4 x 910	895,5	146,6	2xDN80	2xDN80		
VDD6T902C	365,2	277,5	115728	98011	63,5	48,3	17,3	15,93	62	57			E	E	4 x 910	1194,1	195,4	2xDN80	2xDN80		
VDD6T903A	379,2	472,6	189803	138994	65,9	82,2	41,3	17,9	64	59			E	C	6 x 910	901,3	147,5	2xDN80	2xDN80		
VDD6T903B	485,8	338,4	182162	155983	84,5	58,8	31,2	33,74	64	59			E	E	6 x 910	1352,1	221,1	2xDN80	2xDN80		
VDD6T903C	554,7	423,1	173952	147300	96,5	73,6	23,8	24,41	64	59			E	E	6 x 910	1802,8	294,9	2xDN100	2xDN100		
VDD6T904A	506,3	631,2	253171	185556	88,0	109,8	40,7	17,68	65	60			E	D	8 x 910	1205,7	197,1	2xDN100	2xDN100		
VDD6T904B	648,7	451,8	243058	208102	112,8	78,6	30,8	33,32	65	60			D	D	8 x 910	1808,5	295,8	2xDN100	2xDN100		
VDD6T904C	755,1	576,4	232173	196586	131,3	100,2	53,9	55,45	65	60			E	D	8 x 910	2411,4	394,4	2xDN100	2xDN100		
VDD6T905A	636,1	794,1	316539	232116	110,6	138,1	47,0	21,99	66	61			E	D	10 x 910	1510,0	247,0	2xDN100	2xDN100		
VDD6T905B	813,8	567,7	303953	260220	141,5	98,7	33,7	38,39	66	61			E	E	10 x 910	2265,0	370,5	2xDN100	2xDN100		
VDD6T905C	941,1	718,3	290393	245872	163,7	124,9	44,5	45,69	66	61			D	D	10 x 910	3020,0	494,0	2xDN100	2xDN100		
VDD6T906A	760,4	948,3	379906	278676	132,3	164,9	40,2	17,45	67	62			E	C	12 x 910	1814,3	296,8	2xDN100	2xDN100		
VDD6T906B	974,4	678,7	364848	312337	169,5	118,0	30,4	32,88	67	62			E	E	12 x 910	2721,6	445,2	2xDN100	2xDN100		
VDD6T906C	1132,5	862,0	348612	295157	197,0	149,9	49,2	44,55	67	62			D	D	12 x 910	3628,73	593,5	4xDN100	4xDN100		
VDD6T907A	898,5	1118,5	443272	325236	156,3	194,5	62,8	27,16	67	62			E	C	14 x 910	2118,7	346,5	4xDN100	4xDN100		
VDD6T907B	1150,7	801,8	425742	364454	200,1	139,4	47,4	51,31	67	62			D	D	14 x 910	3178,0	519,9	4xDN100	4xDN100		
VDD6T907C	1313,0	1002,0	406831	344442	228,3	174,3	36,1	37,09	67	62			D	D	14 x 910	4237,4	693,1	4xDN100	4xDN100		
VDD6T908A	971,1	1220,0	506639	371796	168,9	212,2	11,9	5,28	69	63			E	D	16 x 910	2423,0	396,4	4xDN100	4xDN100		
VDD6T908B	1327,3	925,0	486637	416572	230,8	160,9	69,5	75,28	69	63			D	D	16 x 910	3634,5	594,6	4xDN100	4xDN100		
VDD6T908C	1513,6	1155,4	465050	393727	263,2	200,9	52,9	54,39	69	63			D	D	16 x 910	4846,0	792,8	4xDN100	4xDN100		
VDD6S902A	200,5	233,8	88812	63259	34,9	40,7	15,2	7,83	58	53			P=1650W I=3,5A n=860 min-1	P=1100W I=1,8A n=660 min-1	D	C	4 x 910	597,5	97,6	2xDN80	2xDN80
VDD6S902B	252,9	172,4	85402	69724	44,0	30,0	13,5	11,64	58	53					D	D	4 x 910	895,5	146,6	2xDN80	2xDN80
VDD6S902C	285,0	212,3	82038	66400	49,6	36,9	11,1	9,99	58	53					C	C	4 x 910	1194,1	195,4	2xDN80	2xDN80
VDD6S903A	307,8	354,7	133328	95086	53,5	61,7	28,5	10,73	60	55					D	C	6 x 910	901,3	147,5	2xDN80	2xDN80
VDD6S903B	392,4	268,1	128271	104695	68,3	46,6	43,2	37,06	60	55					D	D	6 x 910	1352,1	221,1	2xDN80	2xDN80
VDD6S903C	440,7	328,6	123272	99759	76,6	57,1	35,3	31,5	60	55					C	C	6 x 910	1802,8	294,9	2xDN100	2xDN100
VDD6S904A	411,0	473,5	177843	126912	71,5	82,4	28,2	10,59	61	56					D	C	8 x 910	1205,7	197,1	2xDN100	2xDN100
VDD6S904B	514,5	353,1	171137	139666	89,5	61,4	20,4	21,55	61	56					D	D	8 x 910	1808,5	295,8	2xDN100	2xDN100
VDD6S904C	588,4	439,6	164504	133117	102,3	76,5	34,9	34,52	61	56					C	C	8 x 910	2411,4	394,4	2xDN100	2xDN100
VDD6S905A	516,3	595,3	222358	158737	89,8	103,5	32,5	13,15	62	57					D	C	10 x 910	1510,0	247,0	2xDN100	2xDN100
VDD6S905B	654,3	448,9	214003	174636	113,8	78,1	39,0	40,84	62	57					D	D	10 x 910	2265,0	370,5	2xDN100	2xDN100
VDD6S905C	732,9	547,9	205736	166475	127,5	95,3	28,5	28,45	62	57					C	C	10 x 910	3020,0	494,0	2xDN100	2xDN100
VDD6S906A	617,3	711,2	266872	190562	107,4	123,7	27,8	10,45	63	58					D	C	12 x 910	1814,3	296,8	2xDN100	2xDN100
VDD6S906B	785,2	539,4	256869	209606	136,6	93,8	38,0	41,87	63	58					D	D	12 x 910	2721,6	445,2	2xDN100	2xDN100
VDD6S906C	882,4	657,5	246967	199832	153,5	114,4	31,8	27,74	63	58					C	C	12 x 910	3628,73	593,5	4xDN100	4xDN100
VDD6S907A	729,0	838,0	311386	222386	126,8	145,7	43,4	16,21	63	58	D	C			14 x 910	2118,7	346,5	4xDN100	4xDN100		
VDD6S907B	911,9	626,2	299735	244576	158,6	108,9	31,4	33,15	63	58	D	D			14 x 910	3178,0	519,9	4xDN100	4xDN100		
VDD6S907C	1037,9	774,0	288198	233189	180,5	134,6	49,2	43	63	58	C	C			14 x 910	4237,4	693,1	4xDN100	4xDN100		
VDD6S908A	840,9	964,9	355900	254211	146,2	167,8	63,6	23,67	64	59	D	C			16 x 910	2423,0	396,4	4xDN100	4xDN100		
VDD6S908B	1052,2	722,1	342601	279546	183,0	125,6	46,4	48,6	64	59	D	C			16 x 910	3634,5	594,6	4xDN100	4xDN100		
VDD6S908C	1179,0	880,9	329429	266546	205,1	153,2	34,2	33,83	64	59	C	C			16 x 910	4846,0	792,8	4xDN100	4xDN100		
VDD6L902A	166,2	131,3	65853	46320	28,9	22,8	10,9	7,19	51	44	P=900W I=2,2A n=640 min-1	P=470W I=1,05A n=440 min-1			C	B	4 x 910	597,5	97,6	2xDN80	2xDN80
VDD6L902B	204,7	155,4	63130	43679	35,6	27,0	9,4	5,73	51	44					C	B	4 x 910	895,5	146,6	2xDN80	2xDN80
VDD6L902C	226,0	166,3	60591	41419	39,3	28,9	7,4	4,29	51	44					C	B	4 x 910	1194,1	195,4	2xDN80	2xDN80
VDD6L903A	258,3	203,8	98871	69573	44,9	35,4	34,7	22,85	53	46					C	B	6 x 910	901,3	147,5	2xDN80	2xDN80
VDD6L903B	316,7	240,0	94824	65638	55,1	41,7	29,5	18,08	53	46					C	B	6 x 910	1352,1	221,1	2xDN80	2xDN80
VDD6L903C	348,4	255,9	91045	62265	60,6	44,5	23,0	13,41	53	46					B	B	6 x 910	1802,8	294,9	2xDN100	2xDN100
VDD6L904A	347,2	273,9	131888	92826	60,4	47,6	46,4	30,55	54	47					C	B	8 x 910	1205,7	197,1	2xDN100	2xDN100
VDD6L904B	423,6	321,1	126517	87596	73,7	55,8	32,3	19,8	54	47					C	B	8 x 910	1808,5	295,8	2xDN100	2xDN100
VDD6L904C	465,1	341,6	121499	83111	80,9	59,4	22,7	13,24	54	47					B	B	8 x 910	2411,4	394,4	2xDN100	2xDN100
VDD6L905A	432,5	341,3	164904	116078	75,2	59,4	38,3	25,17	55	48					C	B	10 x 910	1510,0	247,0	2xDN100	2xDN100
VDD6L905B	535,9	405,6	158210	109554	93,2	70,5	60,7	36,91	55	48					C	B	10 x 910	2265,0	370,5	2xDN100	2xDN100
VDD6L905C	588,2	431,3	151952	103957	102,3	75,0	42,9	24,79	55	48					B	B	10 x 910	3020,0	494,0	2xDN100	2xDN100
VDD6L906A	525,0	414,0	197921	139330	91,3	72,0	64,3	42,26	56	49					C	B	12 x 910	1814,3	296,8	2xDN100	2xDN100
VDD6L906B	640,2	485,1	189903	131511	111,3	84,4	44,7	27,41	56	49					C	B	12 x 910	2721,6	445,2	2xDN100	2xDN100
VDD6L906C	703,0	515,7	182405	124802	122,3	89,7	31,6	18,28	56	49					B	B	12 x 910	3628,73	593,5	4xDN100	4xDN100
VDD6L907A	612,1	482,8	230938	162583	106,5	84,0	60,8	40,02	56	49			C	B	14 x 910	2118,7	346,5	4xDN100	4xDN100		
VDD6L907B	745,8	565,3	221595	153469	129,7	98,3	40,2	24,76	56	49			C	B	14 x 910	3178,0	519,9	4xDN100	4xDN100		
VDD6L907C	825,8	605,4	212858	145648	143,6	105,3	48,8	28,21	56	49			B	B	14 x 910	4237,4	693,1	4xDN10			

Model	Capacity		Airflow		Fluid flow		Pressure drop fluid		Lp [dB(A)]*		Motor (3/400V-50Hz)		E.E.C.**		Fans	Surface	Tube volume	Conn.	
	kW		m³/h		m³/h		kPa		(10m)		Δ	Y	Δ	Y	N° x D [mm]	m²	dm³	mm	
	Δ	Y	Δ	Y	Δ	Y	Δ	Y	Δ	Y								Inlet	Outlet
VDD6Q902A	124,5	105,6	42911	34059	21,7	18,4	6,5	4,89	41	35	P=270W I=0.7A n=390 min-1	P=140W I=0.32A n=250 min-1	B	A	4 x 910	597,5	97,6	2xDN80	2xDN80
VDD6Q902B	148,0	121,7	40969	32090	25,7	21,2	5,3	3,7	41	35			A	A	4 x 910	895,5	146,6	2xDN80	2xDN80
VDD6Q902C	158,6	127,7	39147	30345	27,6	22,2	3,9	2,69	41	35			A	A	4 x 910	1194,1	195,4	2xDN80	2xDN80
VDD6Q903A	193,2	163,8	64431	51156	33,6	28,5	20,8	15,61	43	37			B	A	6 x 910	901,3	147,5	2xDN80	2xDN80
VDD6Q903B	228,1	187,8	61546	48225	39,7	32,7	16,4	11,69	43	37			A	A	6 x 910	1352,1	221,1	2xDN80	2xDN80
VDD6Q903C	244,0	196,2	58835	45625	42,4	34,1	12,3	8,4	43	37			A	A	6 x 910	1802,8	294,9	2xDN100	2xDN100
VDD6Q904A	262,2	221,9	85951	68253	45,6	38,6	47,2	35,09	44	38			B	A	8 x 910	1205,7	197,1	2xDN100	2xDN100
VDD6Q904B	308,6	253,9	82122	64360	53,7	44,2	36,8	26,18	44	38			A	A	8 x 910	1808,5	295,8	2xDN100	2xDN100
VDD6Q904C	329,4	264,7	78522	60904	57,3	46,0	27,6	18,75	44	38			A	A	8 x 910	2411,4	394,4	2xDN100	2xDN100
VDD6Q905A	328,6	278,1	107471	85350	57,1	48,4	52,6	39,1	45	39			B	A	10 x 910	1510,0	247,0	2xDN100	2xDN100
VDD6Q905B	385,6	317,2	102698	80495	67,1	55,2	33,7	23,98	45	39			A	A	10 x 910	2265,0	370,5	2xDN100	2xDN100
VDD6Q905C	414,8	333,1	98209	76183	72,1	57,9	51,3	34,9	45	39			A	A	10 x 910	3020,0	494,0	2xDN100	2xDN100
VDD6Q906A	392,5	332,3	128990	102447	68,3	57,8	38,7	28,8	46	40			B	A	12 x 910	1814,3	296,8	2xDN100	2xDN100
VDD6Q906B	466,1	383,3	123274	96630	81,1	66,7	56,2	39,98	46	40			A	A	12 x 910	2721,6	445,2	2xDN100	2xDN100
VDD6Q906C	496,5	398,9	117896	91461	86,3	69,4	37,9	25,81	46	40			A	A	12 x 910	3628,73	593,5	4xDN100	4xDN100
VDD6Q907A	457,6	387,5	150509	119543	79,6	67,4	36,7	27,28	46	40			B	A	14 x 910	2118,7	346,5	4xDN100	4xDN100
VDD6Q907B	541,3	445,3	143850	112765	94,1	77,4	38,4	27,29	46	40			A	A	14 x 910	3178,0	519,9	4xDN100	4xDN100
VDD6Q907C	581,9	467,3	137582	106740	101,2	81,3	58,4	39,67	46	40			A	A	14 x 910	4237,4	693,1	4xDN100	4xDN100
VDD6Q908A	526,5	445,7	172029	136640	91,6	77,5	53,5	39,79	47	41			B	A	16 x 910	2423,0	396,4	4xDN100	4xDN100
VDD6Q908B	621,8	511,4	164426	128899	108,1	88,9	55,8	39,71	47	41			A	A	16 x 910	3634,5	594,6	4xDN100	4xDN100
VDD6Q908C	662,4	532,2	157269	122018	115,2	92,5	37,7	25,64	47	41	A	A	16 x 910	4846,0	792,8	4xDN100	4xDN100		
VDD6R902A	118,6	85,7	40031	25725	20,6	14,9	6,0	3,41	40	30	P=270W I=0.7A n=390 min-1	P=140W I=0.32A n=250 min-1	A	A	4 x 910	597,5	97,6	2xDN80	2xDN80
VDD6R902B	139,8	96,2	38117	24106	24,3	16,7	4,8	2,45	40	30			A	A	4 x 910	895,5	146,6	2xDN80	2xDN80
VDD6R902C	149,0	99,1	36347	22719	25,9	17,2	3,5	1,72	40	30			A	A	4 x 910	1194,1	195,4	2xDN80	2xDN80
VDD6R903A	184,1	132,7	60111	38645	32,0	23,1	19,2	10,75	42	32			A	A	6 x 910	901,3	147,5	2xDN80	2xDN80
VDD6R903B	215,5	148,2	57266	36232	37,5	25,8	14,8	7,69	42	32			A	A	6 x 910	1352,1	221,1	2xDN80	2xDN80
VDD6R903C	229,1	151,9	54632	34163	39,8	26,4	11,0	5,36	42	32			A	A	6 x 910	1802,8	294,9	2xDN100	2xDN100
VDD6R904A	249,5	179,7	80191	51565	43,4	31,3	43,2	24,14	43	33			A	A	8 x 910	1205,7	197,1	2xDN100	2xDN100
VDD6R904B	291,4	200,1	76414	48358	50,7	34,8	33,2	17,21	43	33			A	A	8 x 910	1808,5	295,8	2xDN100	2xDN100
VDD6R904C	309,2	204,7	72915	45606	53,8	35,6	24,7	11,94	43	33			A	A	8 x 910	2411,4	394,4	2xDN100	2xDN100
VDD6R905A	312,7	225,2	100270	64484	54,4	39,2	48,1	26,89	44	34			A	A	10 x 910	1510,0	247,0	2xDN100	2xDN100
VDD6R905B	364,1	250,1	95562	60484	63,3	43,5	30,4	15,76	44	34			A	A	10 x 910	2265,0	370,5	2xDN100	2xDN100
VDD6R905C	389,4	257,5	91198	57049	67,7	44,8	45,9	22,19	44	34			A	A	10 x 910	3020,0	494,0	2xDN100	2xDN100
VDD6R906A	373,6	269,1	120350	77403	65,0	46,8	35,5	19,82	45	35			A	A	12 x 910	1814,3	296,8	2xDN100	2xDN100
VDD6R906B	440,1	302,1	114710	72610	76,5	52,5	50,7	26,26	45	35			A	A	12 x 910	2721,6	445,2	2xDN100	2xDN100
VDD6R906C	466,1	308,4	109481	68492	81,1	53,6	33,9	16,42	45	35			A	A	12 x 910	3628,73	593,5	4xDN100	4xDN100
VDD6R907A	439,1	316,2	140429	90322	76,4	55,0	54,8	30,61	45	35			A	A	14 x 910	2118,7	346,5	4xDN100	4xDN100
VDD6R907B	511,1	351,0	133858	84735	88,9	61,0	34,6	17,94	45	35			A	A	14 x 910	3178,0	519,9	4xDN100	4xDN100
VDD6R907C	546,2	361,2	127764	79935	95,0	62,8	52,2	25,22	45	35			A	A	14 x 910	4237,4	693,1	4xDN100	4xDN100
VDD6R908A	501,1	360,9	160508	103242	87,1	62,8	49,0	27,37	46	36			A	A	16 x 910	2423,0	396,4	4xDN100	4xDN100
VDD6R908B	587,1	403,0	153006	96861	102,1	70,1	50,3	26,09	46	36			A	A	16 x 910	3634,5	594,6	4xDN100	4xDN100
VDD6R908C	621,8	411,5	146047	91378	108,1	71,6	33,7	16,31	46	36	A	A	16 x 910	4846,0	792,8	4xDN100	4xDN100		

Nominal capacities according to standard EN1048 (water Tair=25°C, Tin=40°C, Tout=35°C).

*See the General Contents for more details.

**Energy Efficiency Class: see "General Contents" for more details.

Model	Capacity		Airflow		Fluid flow		Pressure drop fluid		Lp[dB(A)]		Motor (3/400V-50Hz)		E.E.C.		Fans	Surface	Tube volume	Conn.			
	kW		m³/h		m³/h		kPa		(10m)		Δ	Y	Δ	Y	N° x D [mm]	m²	dm³	mm			
	Δ	Y	Δ	Y	Δ	Y	Δ	Y	Δ	Y								Inlet	Outlet		
VDD6L1002A	234,9	203,3	116023	90821	40,9	35,4	20,1	15,6	59	54	P=2200W I=4,2A n=670 min-1	P=1500W I=2,7A n=530 min-1	E	D	4 x 1000	597,5	97,6	2xDN80	2xDN80		
VDD6L1002B	294,0	248,1	107055	83006	51,1	43,1	17,6	13,1	59	54			D	D	4 x 1000	895,5	146,6	2xDN80	2xDN80		
VDD6L1002C	327,7	270,5	99278	76517	57,0	47,0	14,3	10,1	59	54			D	C	4 x 1000	1194,1	195,4	2xDN80	2xDN80		
VDD6L1003A	361,1	312,3	174343	136508	62,8	54,3	37,9	29,3	61	56			D	D	6 x 1000	901,3	147,5	2xDN80	2xDN80		
VDD6L1003B	448,6	378,3	160994	124859	78,0	65,8	27,1	20,0	61	56			D	D	6 x 1000	1352,1	221,1	2xDN80	2xDN80		
VDD6L1003C	507,3	418,5	149386	115161	88,2	72,8	45,0	32,1	61	56			D	C	6 x 1000	1802,8	294,9	2xDN100	2xDN100		
VDD6L1004A	482,3	417,1	232659	182193	83,9	72,5	37,4	28,9	62	57			D	D	8 x 1000	1205,7	197,1	2xDN100	2xDN100		
VDD6L1004B	599,2	505,3	214931	166710	104,2	87,9	26,7	19,8	62	57			D	D	8 x 1000	1808,5	295,8	2xDN100	2xDN100		
VDD6L1004C	677,7	559,0	199491	153803	117,9	97,2	44,5	31,7	62	57			D	C	8 x 1000	2411,4	394,4	2xDN100	2xDN100		
VDD6L1005A	606,1	524,1	290975	227878	105,4	91,1	43,1	33,3	63	58			D	D	10 x 1000	1510,0	247,0	2xDN100	2xDN100		
VDD6L1005B	762,1	642,8	268867	208561	132,5	111,8	50,7	37,8	63	58			D	D	10 x 1000	2265,0	370,5	2xDN100	2xDN100		
VDD6L1005C	844,9	697,2	249595	192444	146,9	121,2	36,7	26,2	63	58			D	C	10 x 1000	3020,0	494,0	2xDN100	2xDN100		
VDD6L1006A	724,7	626,7	349290	273562	126,0	109,0	36,9	28,6	64	59			D	D	12 x 1000	1814,3	296,8	2xDN100	2xDN100		
VDD6L1006B	900,4	759,3	322802	250411	156,6	132,0	26,4	19,5	64	59			D	D	12 x 1000	2721,6	445,2	2xDN100	2xDN100		
VDD6L1006C	1016,9	838,9	299699	231085	176,9	145,9	40,6	29,0	64	59			D	C	12 x 1000	3628,73	593,5	4xDN100	4xDN100		
VDD6L1007A	856,2	740,2	407605	319246	148,9	128,7	57,6	44,6	64	59			D	D	14 x 1000	2118,7	346,5	4xDN100	4xDN100		
VDD6L1007B	1063,2	897,0	376737	292260	184,9	156,0	41,2	30,7	64	59			D	D	14 x 1000	3178,0	519,9	4xDN100	4xDN100		
VDD6L1007C	1197,0	986,8	349802	269725	208,2	171,6	63	44,8	64	59			D	C	14 x 1000	4237,4	693,1	4xDN100	4xDN100		
VDD6L1008A	925,9	802,7	465920	364929	161,0	139,6	10,9	8,6	65	60			E	D	16 x 1000	2423,0	396,4	4xDN100	4xDN100		
VDD6L1008B	1226,2	1034,0	430672	334110	213,3	179,8	60,4	45,0	65	60			D	D	16 x 1000	3634,5	594,6	4xDN100	4xDN100		
VDD6L1008C	1359,2	1121,2	399906	308366	236,4	195,0	43,7	31,1	65	60			D	C	16 x 1000	4846,0	792,8	4xDN100	4xDN100		
VDD6Q1002A	180,9	145,4	75193	53790	31,5	25,3	12,7	8,6	45	38			P=860W I=2,0A n=420 min-1	P=500W I=0,97A n=310 min-1	C	B	4 x 1000	597,5	97,6	2xDN80	2xDN80
VDD6Q1002B	216,3	166,4	68172	47770	37,6	28,9	10,3	6,5	45	38					C	B	4 x 1000	895,5	146,6	2xDN80	2xDN80
VDD6Q1002C	228,9	172,1	61551	43192	39,8	29,9	7,5	4,6	45	38					B	B	4 x 1000	1194,1	195,4	2xDN80	2xDN80
VDD6Q1003A	281,5	226,1	113018	80911	49,0	39,3	40,4	27,4	47	40					C	B	6 x 1000	901,3	147,5	2xDN80	2xDN80
VDD6Q1003B	335,3	257,7	102600	71912	58,3	44,8	32,6	20,6	47	40					C	B	6 x 1000	1352,1	221,1	2xDN80	2xDN80
VDD6Q1003C	353,5	265,4	92728	65051	61,5	46,2	23,6	14,3	47	40					B	B	6 x 1000	1802,8	294,9	2xDN100	2xDN100
VDD6Q1004A	378,6	304,0	150841	108030	65,8	52,9	54,1	36,7	48	41					C	B	8 x 1000	1205,7	197,1	2xDN100	2xDN100
VDD6Q1004B	448,9	344,9	137026	96052	78,1	60,0	35,8	22,6	48	41					B	B	8 x 1000	1808,5	295,8	2xDN100	2xDN100
VDD6Q1004C	478,8	358,7	123902	86908	83,3	62,4	53,3	32,0	48	41					B	B	8 x 1000	2411,4	394,4	2xDN100	2xDN100
VDD6Q1005A	471,7	378,9	188663	135149	82,0	65,9	44,6	30,3	49	42					C	B	10 x 1000	1510,0	247,0	2xDN100	2xDN100
VDD6Q1005B	559,7	430,2	171451	120192	97,3	74,8	29,5	18,6	49	42					B	B	10 x 1000	2265,0	370,5	2xDN100	2xDN100
VDD6Q1005C	597,8	447,9	155076	108766	104,0	77,9	44,1	26,5	49	42					B	B	10 x 1000	3020,0	494,0	2xDN100	2xDN100
VDD6Q1006A	566,8	455,3	226484	162268	98,6	79,2	45,7	31,0	50	43					B	B	12 x 1000	1814,3	296,8	2xDN100	2xDN100
VDD6Q1006B	678,9	521,3	205875	144331	118,1	90,7	49,6	31,2	50	43					B	B	12 x 1000	2721,6	445,2	2xDN100	2xDN100
VDD6Q1006C	714,2	535,8	186249	130624	124,2	93,2	32,2	19,5	50	43					C	B	12 x 1000	3628,73	593,5	4xDN100	4xDN100
VDD6Q1007A	658,0	528,7	264306	189386	114,4	92,0	36,2	24,6	50	43	B	B			14 x 1000	2118,7	346,5	4xDN100	4xDN100		
VDD6Q1007B	791,0	607,6	240299	168471	137,6	105,7	44,7	28,1	50	43	B	B			14 x 1000	3178,0	519,9	4xDN100	4xDN100		
VDD6Q1007C	839,8	629,1	217422	152481	146,0	109,4	50,3	30,2	50	43	C	B			14 x 1000	4237,4	693,1	4xDN100	4xDN100		
VDD6Q1008A	759,0	609,6	302127	216505	132,0	106,0	53,1	36,0	51	44	C	B			16 x 1000	2423,0	396,4	4xDN100	4xDN100		
VDD6Q1008B	900,4	691,8	274722	192610	156,6	120,3	35,2	22,2	51	44	B	B			16 x 1000	3634,5	594,6	4xDN100	4xDN100		
VDD6Q1008C	959,8	719,0	248595	174339	166,9	125,0	48,5	29,1	51	44	D	D			16 x 1000	4846,0	792,8	4xDN100	4xDN100		
VDD6R1002A	167,3	123,2	66534	42246	29,1	21,4	11,0	6,4	43	34	P=670W I=1,4A n=380 min-1	P=330W I=0,67A n=250 min-1			C	B	4 x 1000	597,5	97,6	2xDN80	2xDN80
VDD6R1002B	197,0	138,5	59890	37643	34,3	24,1	8,7	4,7	43	34					B	B	4 x 1000	895,5	146,6	2xDN80	2xDN80
VDD6R1002C	205,7	140,2	53830	33809	35,8	24,4	6,2	3,2	43	34					B	B	4 x 1000	1194,1	195,4	2xDN80	2xDN80
VDD6R1003A	260,2	191,3	100017	63532	45,3	33,3	35,2	20,4	45	36					C	B	6 x 1000	901,3	147,5	2xDN80	2xDN80
VDD6R1003B	305,2	213,7	90155	56673	53,1	37,2	27,6	14,6	45	36					B	B	6 x 1000	1352,1	221,1	2xDN80	2xDN80
VDD6R1003C	317,9	215,8	81107	50939	55,3	37,5	19,7	9,9	45	36					B	A	6 x 1000	1802,8	294,9	2xDN100	2xDN100
VDD6R1004A	349,9	257,3	133495	84817	60,9	44,7	47,1	27,5	46	37					C	B	8 x 1000	1205,7	197,1	2xDN100	2xDN100
VDD6R1004B	408,6	286,1	120418	75701	71,1	49,8	30,3	16,0	46	37					B	A	8 x 1000	1808,5	295,8	2xDN100	2xDN100
VDD6R1004C	430,1	291,5	108381	68068	74,8	50,7	44,1	22,2	46	37					B	A	8 x 1000	2411,4	394,4	2xDN100	2xDN100
VDD6R1005A	436,1	320,4	166975	106101	75,8	55,7	38,8	22,5	47	38					C	B	10 x 1000	1510,0	247,0	2xDN100	2xDN100
VDD6R1005B	517,0	361,6	150680	94728	89,9	62,9	56,9	30,0	47	38					B	A	10 x 1000	2265,0	370,5	2xDN100	2xDN100
VDD6R1005C	537,1	364,1	135655	85196	93,4	63,3	36,5	18,4	47	38					B	A	10 x 1000	3020,0	494,0	2xDN100	2xDN100
VDD6R1006A	524,0	385,0	200453	127385	91,1	67,0	39,8	23,1	48	39					C	B	12 x 1000	1814,3	296,8	2xDN100	2xDN100
VDD6R1006B	617,8	432,3	180941	113755	107,4	75,2	41,9	22,2	48	39					B	A	12 x 1000	2721,6	445,2	2xDN100	2xDN100
VDD6R1006C	642,3	435,6	162929	102325	111,7	75,8	26,9	13,6	48	39					B	A	12 x 1000	3628,73	593,5	4xDN100	4xDN100
VDD6R1007A	608,4	447,2	233931	148669	105,8	77,8	31,5	18,3	48	39			C	B	14 x 1000	2118,7	346,5	4xDN100	4xDN100		
VDD6R1007B	719,9	503,9	211202	132782	125,2	87,6	37,8	20,0	48	39			B	A	14 x 1000	3178,0	519,9	4xDN100	4xDN100		
VDD6R1007C	754,5	511,3	190202	119453	131,2	88,9	41,6	20,9	48	39			B	A	14 x 1000	4237,4	6				

Alfa V- VDD/VDD6

Drawings

Model	Dimensions	Weight
	mm	Kg
	A	
VDD_802/902/1002A	2940	585
VDD_802/902/1002B	2940	675
VDD_802/902/1002C	2940	774
VDD_803/903/1003A	4250	765
VDD_803/903/1003B	4250	945
VDD_803/903/1003C	4250	1125
VDD_804/904/1004A	5560	1152
VDD_804/904/1004B	5560	1332
VDD_804/904/1004C	5560	1530
VDD_805/905/1005A	6870	1440
VDD_805/905/1005B	6870	1665
VDD_805/905/1005C	6870	1913
VDD_806/906/1006A	8190	1620
VDD_806/906/1006B	8190	1890
VDD_806/906/1006C	8190	2250
VDD_807/907/1007A	9490	2070
VDD_807/907/1007B	9490	2340
VDD_807/907/1007C	9490	2691
VDD_808/908/1008A	10800	2430
VDD_808/908/1008B	10800	2682
VDD_808/908/1008C	10800	3042
VDD6_802/902/1002A	2940	690
VDD6_802/902/1002B	2940	797
VDD6_802/902/1002C	2940	913
VDD6_803/903/1003A	4250	903
VDD6_803/903/1003B	4250	1115
VDD6_803/903/1003C	4250	1328
VDD6_804/904/1004A	5560	1359
VDD6_804/904/1004B	5560	1572
VDD6_804/904/1004C	5560	1805
VDD6_805/905/1005A	6870	1699
VDD6_805/905/1005B	6870	1965
VDD6_805/905/1005C	6870	2257
VDD6_806/906/1006A	8190	1912
VDD6_806/906/1006B	8190	2230
VDD6_806/906/1006C	8190	2655
VDD6_807/907/1007A	9490	2443
VDD6_807/907/1007B	9490	2761
VDD6_807/907/1007C	9490	3175
VDD6_808/908/1008A	10800	2867
VDD6_808/908/1008B	10800	3165
VDD6_808/908/1008C	10800	3590

We reserve the right to change our technical data without prior notice.

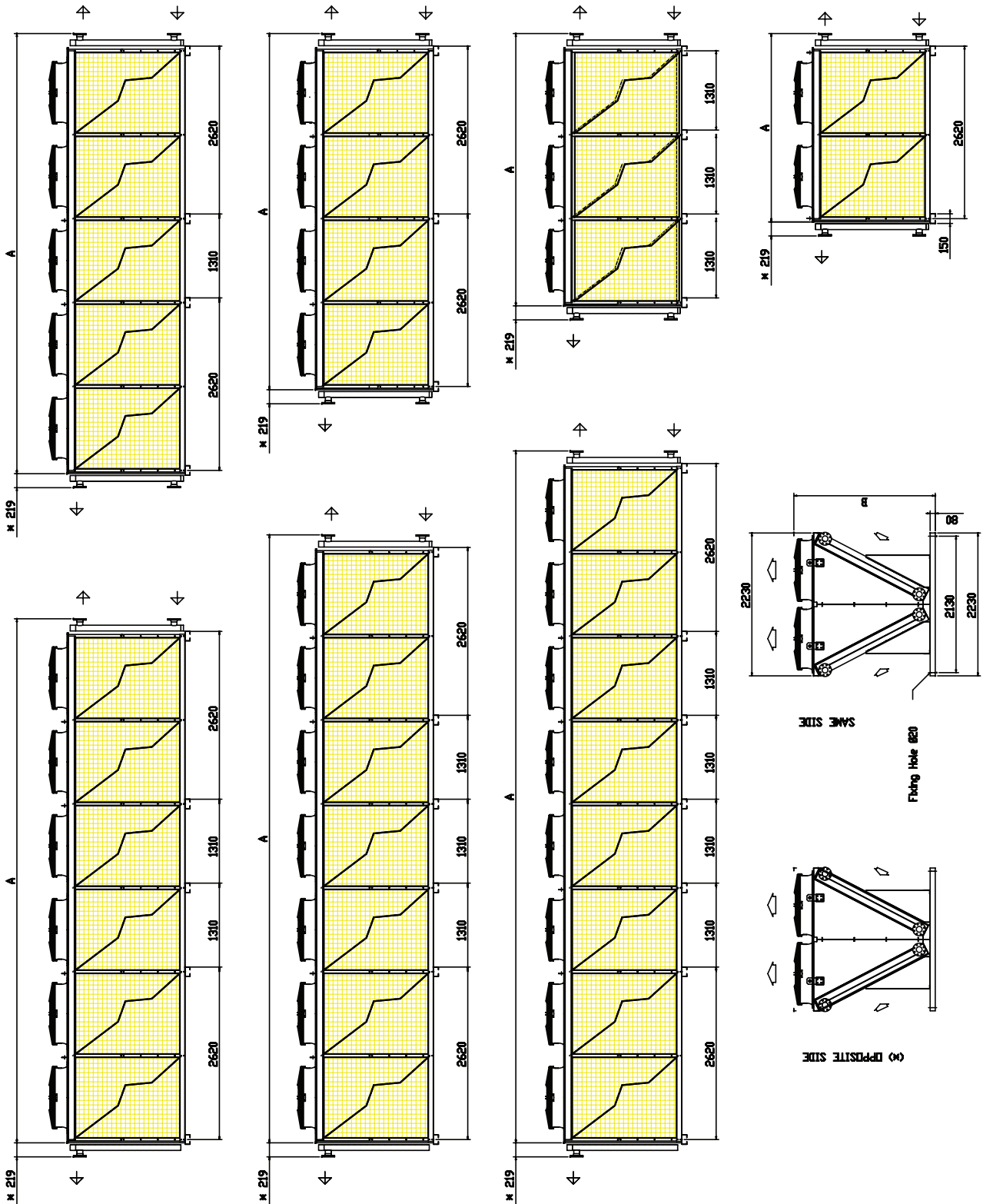

Alfa V- VDD/VDD6

Options

Motor fans



- (a) Fan motor 400 V/3ph - 60Hz, IP54: S/L/Q/R for Ø 800/910
 (b) Fan motor 460 V/3ph - 60Hz, IP54: S/L/Q/R for Ø 800/910

Model:
 Ø 800 (a,b)
 Ø 910(a,b)

Local safety switch wired

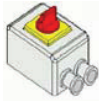

See Electrical Data Page.

Model:
 All Models

Terminal Box

See Electrical Data Page.

Model:
 All Models

Switchboard and cabling

Function

Switchboard for supply and control of fan motors.
 A switchboard can supply up to 8 individual motors or 8 paired motors (i.e. max. of 16 motors).
 Switchboard and cabling are supplied as standard for vertical installation of the unit.
 If you have different needs, please specify these when placing your order.

Operating conditions

Type of installation: External wall mounted
 Protection class: IP55 door closed
 Climate: Normal
 Operating temperature: -10 ÷ +35°C (base) -25 ÷ +50°C (with optionals)
 Ambient relative humidity: <95%
 Altitude: <1000metres above sea level

Electrical data

Insulating nominal voltage: 690V
 Operating voltage: 3Ph. 400Vac
 Frequency: 50Hz
 Auxiliaries voltage: 24-230V
 Nominal current: Max 80A

Mechanical data

Material: Pre-painted galvanized steel
 Fixing plate: Sheet of steel (min. thickness 15/10 Sendzimir galvanized)
 Gasket: Polyurethane
 Door: opening more than 180°.
 Colour: RAL 7035
 Cable gland: metric ISO

Model:
 All Models

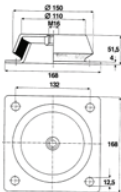
Switchboard Options															
	<p>R anti-condensate resistor 230Vac (operating temperature $-25 \div +35^{\circ}\text{C}$)</p> <p>C cooling fan 230Vac (operating temperature $-10 \div +50^{\circ}\text{C}$)</p> <p>F cooling fan + anti-condensate resistor</p>														
	<p>Model: All Models</p>														
Switchboard with Fan Speed control															
	<p>Switchboard and cabling, including an electronic fan motor speed controller that checks and regulates the speed rotation of the fan's motor, keeping the temperature for dry cooler within the range or preset values. Constant control of the fan speed is achieved by variation of the electrical supply by phase-cut, as determined by the probe signal. The fan speed controller comes pre-connected to the switchboard. If you have different needs, please specify these when placing your order.</p>														
	<p>Model: Ø 630 Ø 800 Ø 910</p>														
Switchboard with Fan Step control															
	<p>Switchboard and cabling, including an automatic on/off switch that checks and regulates the speed rotation of the fan's motor, keeping the temperature of the dry cooler within the range or preset values. Control of the fan speed is achieved by variation of the electrical supply by the ON/OFF device, as determined by the probe signal. The fan step controller comes pre-connected to the switchboard. If you have different needs, please specify these when placing your order.</p>														
	<p>Model: All Models</p>														
Switchboard with Frequency Converter (Inverter)															
	<p>See Electrical Data Page.</p>														
	<p>Model: All Models</p>														
Coil Treatment / Material															
	<p>Thermoguard for industrial or sea coast application. Aluminium fins, pre-coated. Copper fins. Application Use: More information on corrosion prevention can be found in the Miscellaneous section.</p>														
	<p>Model: All Models</p>														
Non-standard fin spacing															
	<p>The standard fin spacing is 2.1mm. Alternative: 2.5mm and 3.2mm</p>														
	<p>Model: All Models</p>														
Spray water															
	<p>Consisting of a pipe system with several fitted spraying nozzles that nebulise water in the air suction of the coil. Spray water comes mounted on delivery.</p>														
	<p>Model: All Models</p>														
Finned coil grid															
	<p>Mesh: 40 mm x 40 mm.</p>														
	<p>Model: All Models</p>														
Vibration Dampers															
	<table border="1"> <thead> <tr> <th>Type</th> <th>H mm</th> <th>A mm</th> <th>B mm</th> <th>C mm</th> <th>D mm</th> <th>Weight Kg</th> </tr> </thead> <tbody> <tr> <td>Single Row</td> <td>51.5</td> <td>132</td> <td>168</td> <td>M16</td> <td>12.5</td> <td>2.15</td> </tr> </tbody> </table> <p>Nuts and bolts are not included with these dampers.</p>	Type	H mm	A mm	B mm	C mm	D mm	Weight Kg	Single Row	51.5	132	168	M16	12.5	2.15
Type	H mm	A mm	B mm	C mm	D mm	Weight Kg									
Single Row	51.5	132	168	M16	12.5	2.15									
	<p>Model: All Models</p>														

Alfa V- VDD/VDD6

Electrical Data

Safety Switch

Function

Local safety switch and cabling for each electric fan motor.

General data

Power Supply:

- 400VAC, 50/60Hz
- Max fuse 16A

Number of poles: 3P

Cabinet Material: Plastic Case

Cabinet Colour: Grey (Yellow-Red Knob)

Protection Class: Min IP65

Ambient Temp.: min. -25°C, max. +50°C

Weight: Approx. 0.4Kg

Dimensions

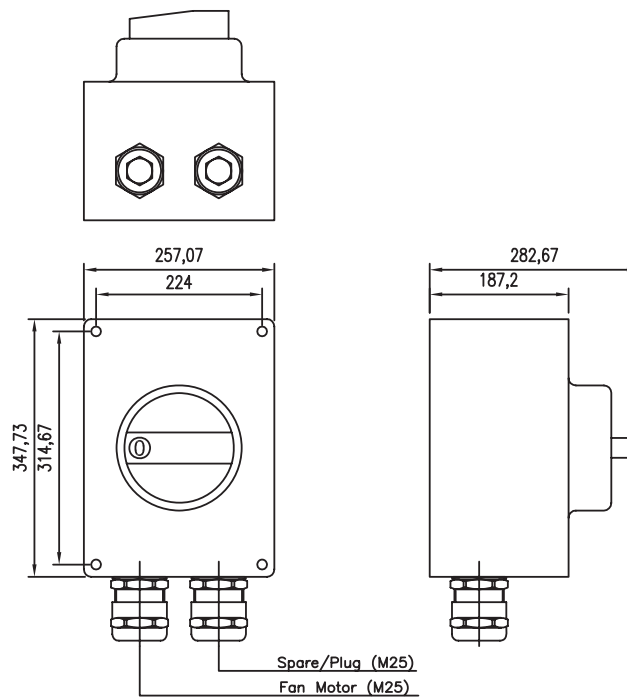

Terminal Box

Function

Connection box for electric fan motor

General data

Material: Plastic
 IP Protection Class: Min RAL 7035
 Colour: Grey RAL 7035
 Insulation Class: II
 Ambient Temp.: min. -40°C, max. +80°C
 Weight: Approx. 0.5Kg.

Dimensions

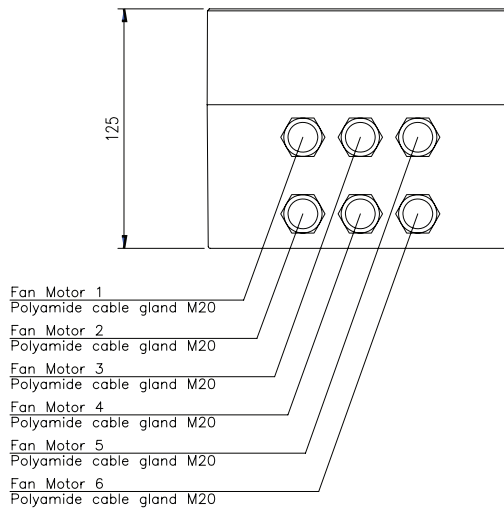
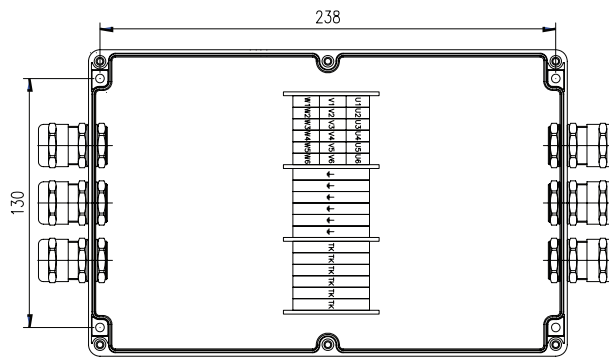

Current Distribution

Function

Current distributors are available as optional accessories. Numerous fans can be connected. In combination with Fcontrol frequency inverters, we can deliver the current distribution with both main switch and bypass function. Features: The current distributor is equipped with plastic housing, IP54 and motor protection units STDT16E with status signal contacts ZB. It is possible to lock the motor protection units with a padlock and use them as repair switches. Fans are directly connected to the motor protection units. Line protection is guaranteed through the integrated short-circuit release. Terminals for supplying the controller output are also integrated. The current distributors are suitable for external mounting (e.g. direct mounting at refrigeration units). It's easy to see the switch position of the motor protection units through the coloured, transparent plastic door.

General data

Current distributor with main switch and bypass function:

- The controller is supplied by the current distributor
- Main switch: 100% - 0 -1
- In position 100%, the connection to the controller output is switched off. This version is for Fcontrol frequency inverters .
- Rated current: Up to 80A

Dimensions

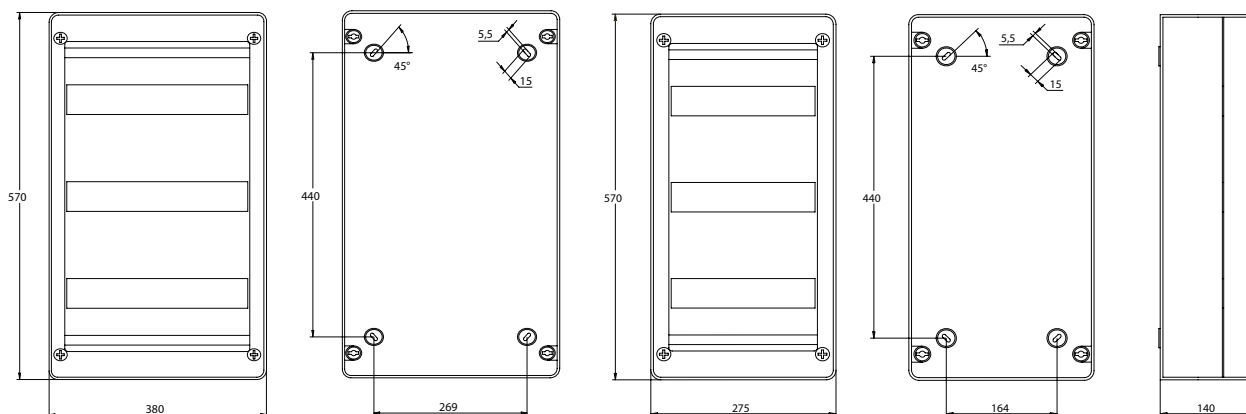

Electric wiring diagram

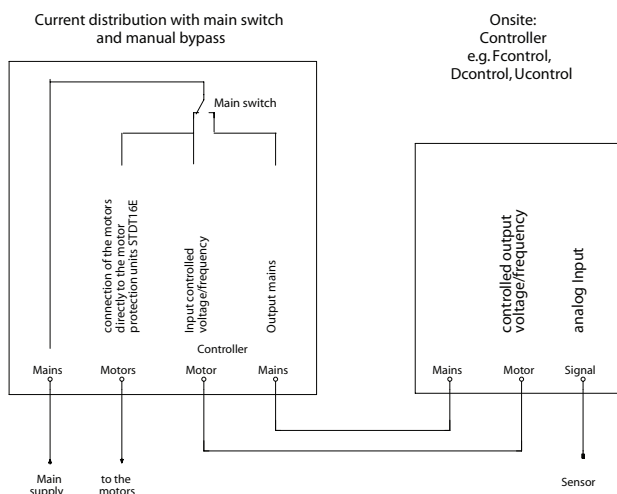

Frequency Converter (Inverter)

Function

Frequency inverter (incl. sine filter) for 3~ motors. Universal controller for refrigeration and air conditioning line input 3~ 208-480V, housing IP54, internal display.

- Speed controller with manual adjustment of output voltage at the unit or via external signal, 2-step operation;
- Temperature control for liquid coolers;
- Pressure control refrigeration (input for refrigerant) for: condensers, dual-circuit condensers;

General data

Equipment/Function

- Integrated SINEFILTER between phase to phase and phase to earth.
- Absolute parallel operation of fans, with no risk of damage to the motor. **Screened motor cables are not required.**
- Integrated process controller (PID free programmable).
- LCD multifunction display with plain language text.
- 2x Analogue Input (0-10 V, 0-20 mA, 4-20 mA, temperature sensor type TF):
 - Analogue 1 for setting of sensor signal.
 - Analogue 2 programmable function for: external set-point, difference value to sensor 1, comparison value (dual-circuit condenser), averaging, and setpoint lowering according to outdoor temperature.
- 1x output 0-10V, programmable function: Constant voltage, proportional modulation, proportional input signal, group control, controller 2.
- 2x digital inputs, programmable function: enable (on / off), external fault, limit output, input 1/2, set-point 1/2, setting internal / external, automatic control / speed manual, reverse control function ("heating" / "cooling"), reset, setting max. speed.
- 2x relay outputs, programmable function: operating indication, fault indication, external fault from digital input, limit modulation, limit input signal, limit offset (deviation actual value setpoint), group control .
- Total motor protection using thermocontact / thermistor connection.
- Interface system with RS485 Interface (MODBUS) or LON® is another alternative option.

Technical data

- Line voltage 3~ 208 BND_480V (-15% / +10%), 50/60Hz.

Rated current*/A	4	8	13	18	22	32	40
Max. line fuse/A	10	10	16	20	25	35	50
Max. heat dissipation*/W	130	210	350	440	540	950	1.100
Weight/Kg	8.8	9.0	22.8	25.4	28.1	29.5	31.8

*at line voltage 400V / 50Hz (for FXDM40A rated current - only possible for fans with $\cos \phi < 0.8$).

- Maximum output frequency 100Hz (for FXDM40, max. 60Hz).
- Clock frequency 16 kHz.
- Max. permissible ambient temperature 40°C (up to 55°C with derating).
- Voltage supply for sensors +24V ±20% (I_{max.} 120 mA).
- Permissible rel. humidity 85% with no condensation .
- Interference emission EN 61000-6-3 1 (unshielded motor cable).
- Interference immunity EN 61000-6-2.

Settings

- Quick start-up with pre-programming modes.
- Set-point 1, set-point 2, manual mode.
- Min. and max. speed, speed limitation e.g. for night operation.
- Group control (via relay or 0-10V signal output).
- Limits: Modulation, input signal, offset (deviation set to actual value).
- Set protection, save user settings.
- Readout events memory (checking the fault log).
- Masking up to 3 settable speed ranges.
- Minimum rate of air on / off.
- Edge frequency, max. frequency / voltage, start voltage.
- U/f characteristics: quadratic or linear.
- Menu language: English, German, Italian, Swedish, etc.
- Inverting: Inputs analogue and digital, analogue out, relays.

Alfa V- VDD/VDD6

Code description

Code No.

VDD or VDD6	1 S	2 80	3 2	4 A
-------------	--------	---------	--------	--------

1) Type of noise level (number of dB(A) to reduce compared with "base" version)

	Standard noise level	Low noise level	Quiet noise level	Residential noise level
	S*	L*	Q*	R*
Fan Ø 800/910/1000 mm	std	-7	-17	-20

2) Fan diameter Ø

80	800 mm
90	910 mm
100	1 000 mm

3) Number of Fans (* available in this version)

1	Ø 800/910/1000 mm
2	
3	
4	
5	
6	
7	
8	

4) The number of rows in the coil (A, B, C)

General Alfa Select Air Legend

Description 1		Description 2	
D	D fan cabling (three phase)	BSFT	Basic Switch Board + Speed Control Temp. + Signal
Y	Y fan cabling (three phase)	BI	Basic Switch Board + Frequency Converter (Inverter)
D/Y	D/Y fan cabling (three phase), single speed fan motor	BSI	Basic Switch Board + Frequency Converter (Inverter) + Signal
S	Single phase	C	Switch Board + Cooling fan
P	Packaged on a pallet	R	Switch Board + Resistor
CR	Packaged in a crate	F	Switch Board + Cooling fan + Resistor
BO	Packaged in a box	PT	Ammonia pump top
Feet	Feet-mounted	PB	Ammonia pump bottom
SW	Safety Switch	AL	Aluminium casing
CB	Terminal Box	SS	Stainless Steel casing
B	Basic Switch Board	AP	Pre-painted Aluminium casing
BS	Basic Switch Board + Signal	PL	Plastic casing
BP	Basic Switch Board + Step Control Pressure	E	Electrical defrost
PT	Basic Switch Board + Step Control Temperature	LE	Low Electrical defrost
BSP	Basic Switch Board + Step Control Pressure + Signal	A	Air Defrost
BST	Basic Switch Board + Step Control Temp. + Signal	HG	Hot Gas Defrost
BFP	Basic Switch Board + Speed Control Pressure	HG+E	Hot Gas Defrost + Electrical Defrost on drip tray
BFT	Basic Switch Board + Speed Control Temperature	W	Water Defrost
BSFP	Basic Switch Board + Speed Control Pres. + Signal	W+E	Water Defrost + Electrical Defrost on drip tray
		AL	Aluminium fin
		CU	Copper fin
		PR	Pre-coated fin
		SS	Stainless steel tube
		TH	Thermoguard treatment
		CF	Cataphoresis treatment
		SC	Sub-cooling circuit
		KW	Spray water kit
		FL	Flanges
		FH	Fan ring heater
		IS	Insulated Drip Tray
		RH	Reheating coil
		SR	Air socket adapter ring
		CW	Air throw fan cowling
		ER	120° elbow reducer
		HN	Hinged fan cowling

Note: valid for the entire product range

Treatment

Corrosion prevention for Air Coolers

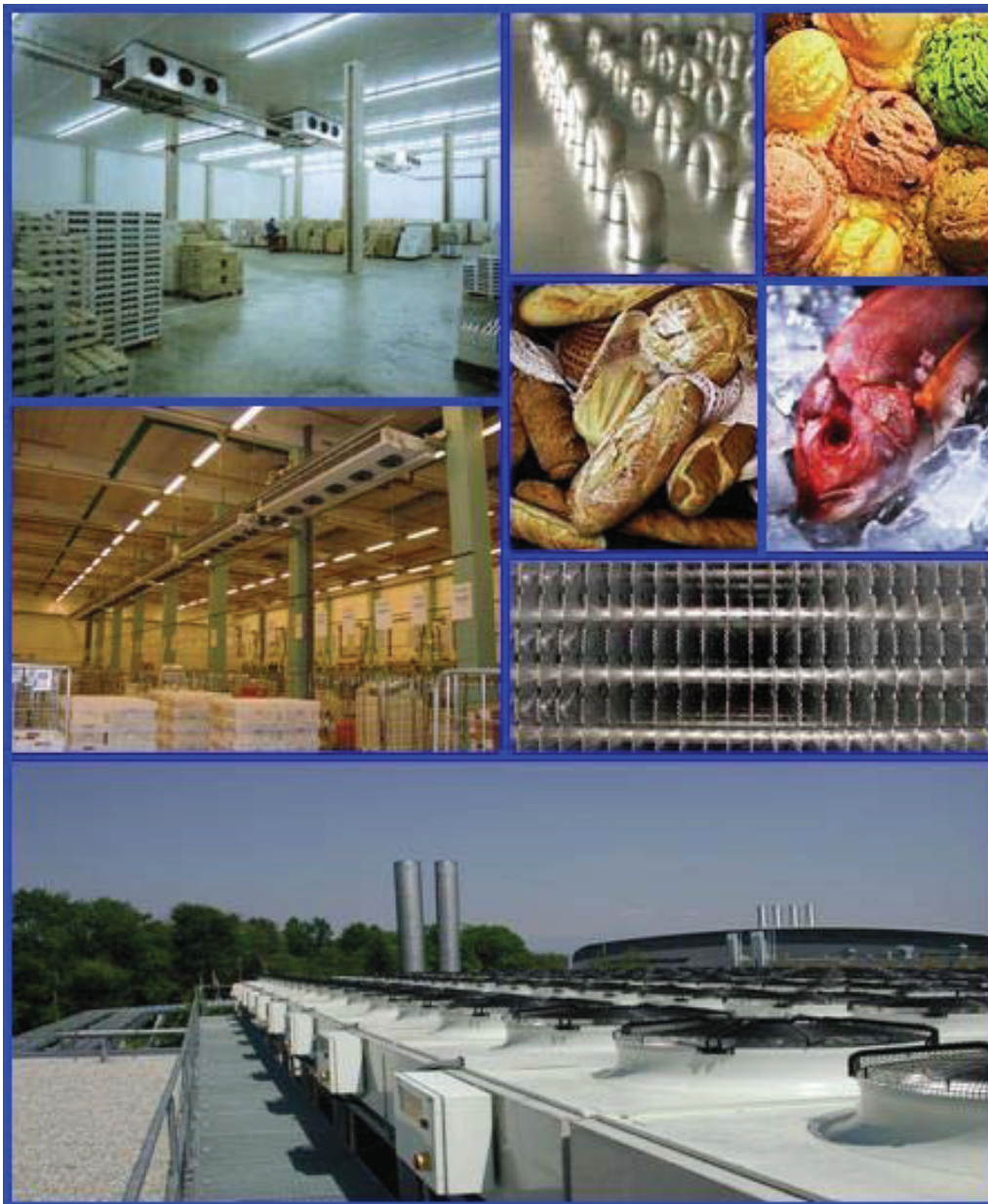

- Corrosion prevention for Air Coolers
- Indoor & outdoor applications
- Material optimisation

Legend

	Component	Material	Description
COIL	Tubes	Cu	Copper
		SS	Stainless steel 304 or 316L
	Fins	Al	Aluminium
		Alprv	Aluminium epoxy
		Cu	Copper
		Al+Cat	Aluminium with Cataphoresis (dip electro-coating)
		Al+T	Aluminium with Thermoguard fin silver coating
	Overall materials or treatments	Al	Aluminium
		StZn	Galvanized steel
		Cat	Cataphoresis (dip electro-coating)
		StZn+T	Galvanized steel +Thermoguard fin silver coating
Casing	Internal drip tray	Al	Aluminium
		SS	Stainless steel 304
	Visible sheets	Al	Aluminium
		Alprv	Aluminium standard coated
		StZn	Galvanized steel
	External drip tray	SS	Stainless steel 304
		Al	Aluminium
		Alprv	Aluminium standard coated
	Fan	Impeller	SS
Al			Aluminium
Al coated			Aluminium standard coated
Motor		Fibreglass	Plastic
		IP54	Outdoor conditions
		IP55	Tropical conditions, high humidity

Indoor installation

APPLICATION		Coil			Casing			Note
Unit Coolers HFC		Tubes	Fins	Overall materials or treatments	Internal drip tray	Visible sheet	External Drip tray	
Meat	Normal use	Cu	Al	Al / StZn	Al	Al / Alprv	Al / Alprv	
	Pre-cooling rooms for half carcasses	Cu	Al / Alprv	Al / StZn	Al	Al / Alprv	Al / Alprv	Additional regular cleaning recommended
	Processing rooms	Cu	Al / Alprv	Al / StZn	Al	Al / Alprv / SS	Al / Alprv / SS	Additional regular cleaning recommended
	Smoke room	SS	Al+Cat	Cat	SS	SS	SS	Aggressive air condition
	Cold room for smoked products	Cu / SS	Al / Alprv	Al / StZn	Al / SS	Al / Alprv / SS	Al / Alprv / SS	Possible aggressive air condition
	Room for salted meat	SS	Al+Cat	Cat	SS	SS	SS	
	Cold room for salted products	SS	Alprv	Al / StZn	Al / SS	Al / Alprv / SS	Al / Alprv / SS	
Fish	Pickled products	SS	Alprv	SS	SS	SS	SS	High presence of acids
	Fresh fish (wet)	Cu	Al / Alprv	Al / StZn	Al	Al / Alprv	Al / Alprv	
	Salting room	SS	Al+Cat	Cat	SS	SS	SS	
	Pickled or salad-based products	SS	Alprv	SS	SS	SS	SS	High concentration of vinegar
	Smoke room	SS	Al+Cat	Cat	SS	SS	SS	Aggressive air condition
Dairy	Cold room for smoked fish	Cu / SS	Al / Alprv	Al / StZn	Al / SS	Al / Alprv / SS	Al / Alprv / SS	Possible aggressive air condition
	Normal use	Cu	Al	Al / StZn	Al	Al / Alprv	Al / Alprv	
	Storage room for cheese or cream, (e.g. Emmenthal, Camembert, Parmesan)	SS	Alprv	Al / StZn	SS	Alprv / SS	Alprv / SS	Low generation of NH ₃ and low relative humidity.
	Storage and maturation room for cheese (e.g. Gruyère, Appenzeller, Daubo, Tilsit, Raclette)	SS	Al+Cat	Cat	SS	SS	SS	High generation of NH ₃ and high air humidity (humidification)
Pasta	Dairy plants with milk vapours and butyric acid	Cu	Al	Al / StZn	Al	Al / Alprv	Al / Alprv	
	Normal use	Cu	Al	Al / StZn	Al	Al / Alprv	Al / Alprv	
	Cold room for fermentation-stop	Cu / SS	Alprv / Al+Cat	Al / StZn / Cat	SS	Alprv / SS	Alprv / SS	High Fin Spacing
Fruit	Chill rooms for hot bakeware giving off vapours from baking additives	SS	Al	Al	Al	Al / Alprv	Al / Alprv	High Fin Spacing
	Normal case	Cu	Al	Al / StZn	Al	Al / Alprv	Al / Alprv	Small DT1
	Cold and storage room for citrus fruits	Cu	Al	Al / StZn	Al	Al / Alprv	Al / Alprv	Ensure ventilation is adequate
Flowers, fruit and vegetables.	Storage and ripening room for bananas.	Cu / SS	Al	Al / StZn	Al	Al / Alprv	AL / Alprv	External static pressure required.
	Normal use	Cu	Al	Al / StZn	Al	Al / Alprv	Al / Alprv	Small DT1
Beverages	Normal use	Cu	Al	Al / StZn	Al	Al / Alprv	Al / Alprv	
	Fermenting cellars with high CO ₂ concentration	Cu / SS	Al / Alprv	Al / SS	Al / SS	Al / Alprv / SS	Al / Alprv / SS	Installation of UC above the fermentation vats
	Cooling of wine cellars	SS	Al / Alprv	Al / StZn	Al	Al / Alprv / SS	Al / Alprv / SS	Room with bottles or casks only
Wood products	Malt plants with germination and roasting technology and a high charge of albumen in the same room.	SS	Al+Cat	Cat	SS	SS	SS	Additional regular cleaning recommended
	Normal use	Cu	Al	Al / StZn	Al	Al / Alprv	Al / Alprv	
	Dry plants for wood with low evaporation (e.g. Pine, Fir, Scots Pine, etc.)	SS	Alprv	Al / StZn	Al	Alprv / SS	Alprv / SS	
Others	Dry plants for wood with strong evaporation (e.g. Oak, tropical timber)	SS	Al+Cat	Cat	SS	SS	SS	
	Swimming Pools	SS	Al+Cat	SS	SS	SS	SS	High humidity, concentrated chlorine
	Deep freezing room (storage)	Cu	Al	Al / StZn	Al	Al / Alprv	AL / Alprv	Normal packaged product
	Logistics warehouse	Cu	Al	Al / StZn	Al	Al / Alprv	AL / Alprv	Normal packaged product

The aforementioned material combinations are based on experience in the application of the components; they are meant as recommendations only. We cannot accept liability for warranty claims derived therein, as the concentrations of the gases released by the goods to be cooled and the effects of cleaning agents can have a decisive influence on the service life of the units. Same colours equate to the same material combinations.

Outdoor installation

APPLICATION		Coil			Casing		Fans		Note
Condensers		Tubes	Fins	Overall materials or treatments	Visible sheet	Feet	Impeller	Motor	
	Normal use	Cu	Al	StZn	StZn Painted	StZn Painted	Al	IP54	
	Industrial environment (e.g. a polluted suburban area)	Cu	Alprv	StZn	StZn Painted	StZn Painted	Al	IP54	Additional regular cleaning recommended
	Sandy conditions	Cu	Alprv	StZn	StZn Painted	StZn Painted	Al	IP54	Observe fin spacing
	Low salt ambient (e.g. away from the coast)	Cu	Alprv	StZn	StZn Painted	StZn Painted	Al	IP54	C3 classification
	High salt ambient (e.g. near the coast)	Cu	Al+T	StZn	StZn Painted	StZn Painted	Al	IP54	C4 classification
APPLICATION		Coil			Casing		Fans		Note
Dry coolers		Tube	Fin	Frame	Visible sheet	Feet	Impeller	Motor	
	Normal use	Cu	Al	StZn	StZn Painted	StZn Painted	Al	IP54	
	Industrial environment (e.g. a polluted sub-urban area)	Cu	Alprv	StZn	StZn Painted	StZn Painted	Al	IP54	Additional regular cleaning recommended
	Heavy industrial area (e.g. steel plant)	Cu	Al+T	StZn+T	StZn Painted	StZn Painted	Al coated	IP54	Observe fin spacing
	Sandy conditions	Cu	Alprv	StZn	StZn Painted	StZn Painted	Al	IP54	Observe fin spacing
	Low salt ambient (e.g. away from the coast)	Cu	Alprv	StZn	StZn Painted	StZn Painted	Al	IP54	C3 classification
	High salt ambient (e.g. near the coast)	Cu	Al+T	StZn	StZn Painted	StZn Painted	Al	IP54	C4 classification
	Offshore platform, ships	SS	Al+T	SS	SS	SS	Fibreglass	IP55	C5 classification

The aforementioned material combinations are based on experience in the application of the components; they are meant as recommendations only. We cannot accept liability for warranty claims derived therein, as the concentrations of the gases released by the goods to be cooled and the effects of cleaning agents can have a decisive influence on the service life of the units. Same colours equate to the same material combinations.

Evaporative Cooling Device

For AlfaBlue Dual and Alfa V



General

The device consists of a pipe system with several fitted spraying nozzles that nebulise water in the air suction of the coil. The spray water solution is used to increase the cooling capacity of the units, by humidification of air around the coil. The adiabatic cooling device consists of a pipe system mounted on the air suction side.

From the spraying nozzles, the water is sprayed into the inlet air. Saturated inlet air causes a significant increase in cooling capacity. The inlet temperature could sink by adiabatic cooling of 5-6 °C. This data strictly depends on ambient temperature, air velocity, airflow and relative humidity.

Applications

Alfa Laval suggests applying the adiabatic cooling device on dry coolers and condensers where there is a reasonable difference between dry bulb and wet bulb temperatures. The following benefits can be achieved by installing a spray water device:

- It becomes possible to overcome heat peaks
- It is possible to cool water to temperatures lower than the ambient air temperature.
- Dry Coolers and Condensers can be designed for a much lower entry air temperature to enable a smaller dimension unit with a smaller heat exchanger surface.

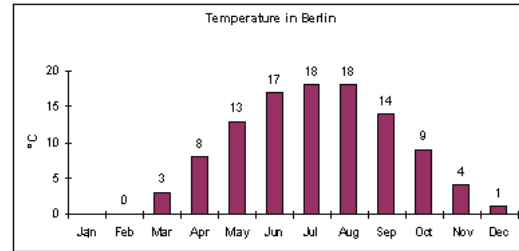

Take Berlin for example: the average temperature in the city last year was 8.6°C. July and August were the hottest months, as showed in the graph during these months the temperature was 18°C. If we don't consider July and August in our statistic, the average temperature decreased to 6.8°C.

Without the spray water device, it is necessary to select a condenser or dry cooler that is able to work during the hottest days of the year: 18°C during the day. With the knowledge that these days represent just 4% of a year, we have to oversize the unit to account for it.

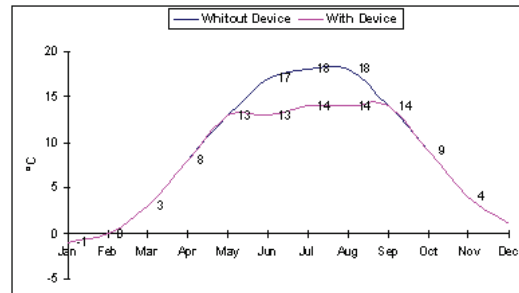

If we consider a new unit with Spray Water Device, it's possible to select a unit to work at 14°C.

Spray Water Device will help to overcome the heat peak during July and August. The average temperature during the year without these months is 6.8°C.

For Berlin, we would suggest using the device during July and August for a around 360 hours, as it is not necessary to use the device at night because the temperature drops.

The efficiency of the spray water device influenced by:

- Relative humidity
- Ambient temperature
- Fan motor airflow
- Wind

When the correlation between **relative humidity** and water absorption degree of efficiency is non-linear. For example, if relative humidity is 90%, the air is almost saturated; using the spray water device will indicate any abnormal dipping. This is due to the air being practically unable to accept more water. It then becomes unnecessary to use the device in these conditions.

If the relative humidity is 30%, using the device is absolutely necessary - the charge of water in the air has to be increased and the air will accept nebulised water because it is far from being saturated.

If the **ambient temperature** increases, the amount of water needed to saturate the air will also rise. Take a look to psychrometric chart on chapter "theory" to better understand.

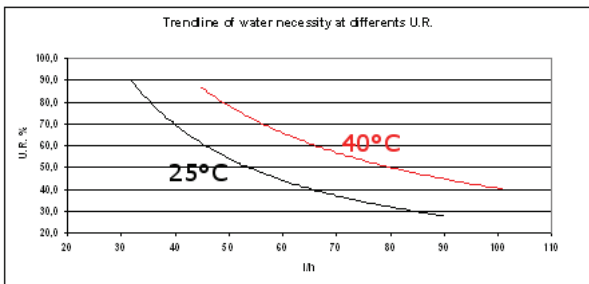

For example, the above graph shows the results of an experimental test, which shows the correlation between relative humidity, temperature and water necessary for humidification.

The **fan motor airflow** is necessary to:

- take the saturated air into the coil.
- increase nebulisation efficiency through the turbulence created.

If the fan motor's rpm decreases, the efficiency of the device will also decrease.

In the presence of light **wind** there are two opposite effects to evaluate:

- Air circulation created by wind increases unit performance – a positive effect.
- Unfortunately however, light wind disrupts droplet trajectory and can create dipping which is negative.

NOTE

Strong wind is always negative. Check your unit installation manual for a better understanding of the reasons and solutions for this.

Spray water devices will not function as they are designed to in the presence of strong wind.

Functionality Range

The spray water device has been designed to work effectively on various sets of external temperature and relative humidity:

T air °C	Relative Humidity %
25÷40	30÷60

NOTE

If the unit has to work outside of this range, please contact

the Alfa Laval Heat Air Exchanger Product Centre to obtain an accurate device design.

Example of theoretical calculation:

Supposing that T ambient (external air) is 25°C / 50% Ur (Point A). The corresponding humidity ratio is 10g/Kg of dry air.

From the point A, following the corresponding line at constant enthalpy, on the saturation line we set Point B; the corresponding humidity ratio is 13g/Kg of dry air.

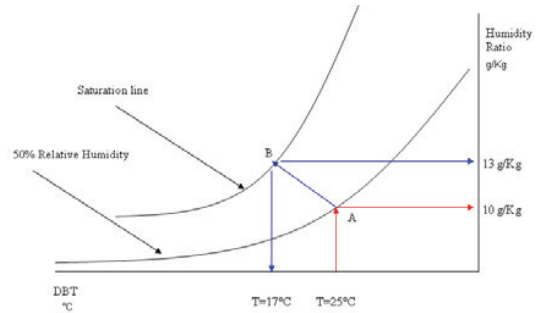

The air after the treatment should be at 17°C, but the humidification efficiency never quite reaches 100%.

The humidification efficiency should be taken as 70%.

For this, the length of line AC is 70% of line AB: $AC = 0.7 \cdot AB$

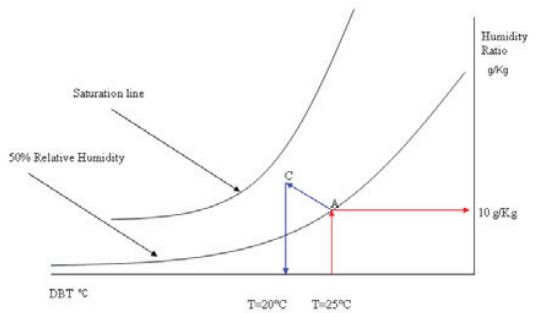

Finally, the inlet temperature before the coil is 20°C.

To find the water flow, see the following example:

$\Delta X = (13 - 10) = 3 \text{ g/Kg dry air}$

The airflow rate can be found with CAS, supposing a total amount of 1000 m³/h.

$M = 1000 \text{ m}^3/\text{h} \times 1.2 \text{ Kg/m}^3 = 1200 \text{ Kg/h}$

The necessary amount of water required to humidify the air is:

$M_w = M \times \Delta X = 1200 \text{ Kg/h} \times 3 \text{ g/Kg} = 3600 \text{ g/h} = 3.6 \text{ l/hour}$

Every hour, you should nebulise 3.6l of water to achieve an efficiency of 80%.

NOTE

Calculation based on the psychrometric chart is affected by a huge number of environmental variables, so it is vital that the Spray Water Device is set up with surrounding conditions in mind. In some surrounding conditions, with a low fan speed rotation, the air pressure drop on the coil could increase due to fine drop accumulation. Alfa Laval strictly recommends selecting an adequate fin spacing for your environment.

V-type standard noise and V-type low noise

MODEL			Length mm	Number of nozzles	Total water flow inlet (l/min)	
Series	Noise level	Ø mm			Electrical wiring.	
					D	Y
VDD	S/L	802/902	2620	4	5.2	2.4
VDD6						
ACV						
VDD	S/L	803/903	3930	6	7.8	3.6
VDD6						
ACV						
VDD	S/L	804/904	5240	8	10.4	4.8
VDD6						
ACV						
VDD	S/L	805/905	6550	10	13	6
VDD6						
ACV						
VDD	S/L	806/906	7860	12	15.6	7.2
VDD6						
ACV						
VDD	S/L	807/907	9170	14	18.2	8.4
VDD6						
ACV						
VDD	S/L	808/908	10480	16	20.8	9.6
VDD6						
ACV						

Electrical wiring D: Every nozzle is designed to work at 2.5bar and nebulise 1.3l/min.

Electrical wiring Y: Every nozzle is designed to work at 2.5bar and nebulise 0.6 l/min.

Models VDDT and VDD6T use the same nozzles as model VDDS and VDD6S.

V-type quiet noise and V-type residential noise

MODEL			Length mm	Number of nozzles	Total water flow inlet (l/min)	
Series	Noise level	Ø mm			Electrical wiring.	
					D	Y
VDD	Q/R	802/902	2620	4	2.4	1.2
VDD6						
ACV						
VDD	Q/R	803/903	3930	6	3.6	1.8
VDD6						
ACV						
VDD	Q/R	804/904	5240	8	4.8	2.4
VDD6						
ACV						
VDD	Q/R	805/905	6550	10	6	3
VDD6						
ACV						
VDD	Q/R	806/906	7860	12	7.2	3.6
VDD6						
ACV						
VDD	Q/R	807/907	9170	14	8.4	4.2
VDD6						
ACV						
VDD	Q/R	808/908	10480	16	9.6	4.8
VDD6						
ACV						

Electrical wiring D: Every nozzle is designed to work at 2.5bar and nebulise 0,6 l/min.

Electrical wiring Y: Every nozzle is designed to work at 2.5bar and nebulise 0.3 l/min.

Double Row Standard noise and Double Row Low noise

MODEL			Length mm	Number of nozzles	Total water flow inlet (l/min)	
Series	Noise level	Ø mm			Electrical wiring.	
					D	Y
BCD	T/S/L	802/902	3500 (T/S) 4200 (L)	8	4.8	2.4
BDD						
BND						
BCD	T/S/L	803/903	5250 (T/S) 6300 (L)	12	7.2	3.6
BDD						
BND						
BCD	T/S/L	804/904	7000 (T/S) 8400 (L)	16	9.6	4.8
BDD						
BND						
BCD	T/S/L	805/905	8750 (T/S) 10500 (L)	20	12	6
BDD						
BND						
BCD	T/S/L	806/906	10500	24	14.4	7.2
BDD						
BND						

T only for Ø 910

Electrical wiring D: Every nozzle is designed to work at 2.5bar and nebulise 0,6 l/min.

Electrical wiring Y: Every nozzle is designed to work at 2.5bar and nebulise 0.3 l/min.

Double Row Quiet noise and Double Row Residential noise

MODEL			Length mm	Number of nozzles	Total water flow inlet (l/min)	
Series	Noise level	Ø mm			Electrical wiring.	
					D	Y
BCD	Q/R	802/902/1002	3500 (Q) 4200 (R)	8	2.4	1.2
BDD						
BND						
BCD	Q/R	803/903/1003	5250 (Q) 6300 (R)	12	3.6	1.8
BDD						
BND						
BCD	Q/R	804/904/1004	7000 (Q) 8400 (R)	16	4.8	2.4
BDD						
BND						
BCD	Q/R	805/905/1005	8750 (Q) 10500 (R)	20	6	3
BDD						
BND						
BCD	Q/R	806/906/1006	10500	24	7.2	3.6
BDD						
BND						

Electrical wiring D: Every nozzle is designed to work at 2.5bar and nebulise 0,3 l/min.

Electrical wiring Y: Every nozzle is designed to work at 1.5bar and nebulise 0,15 l/min.

ATTENTION!

Always check pressure and flow conditions, adjusting them in case of change in environmental conditions. See the troubleshooting section.

Below is a psychrometric chart.

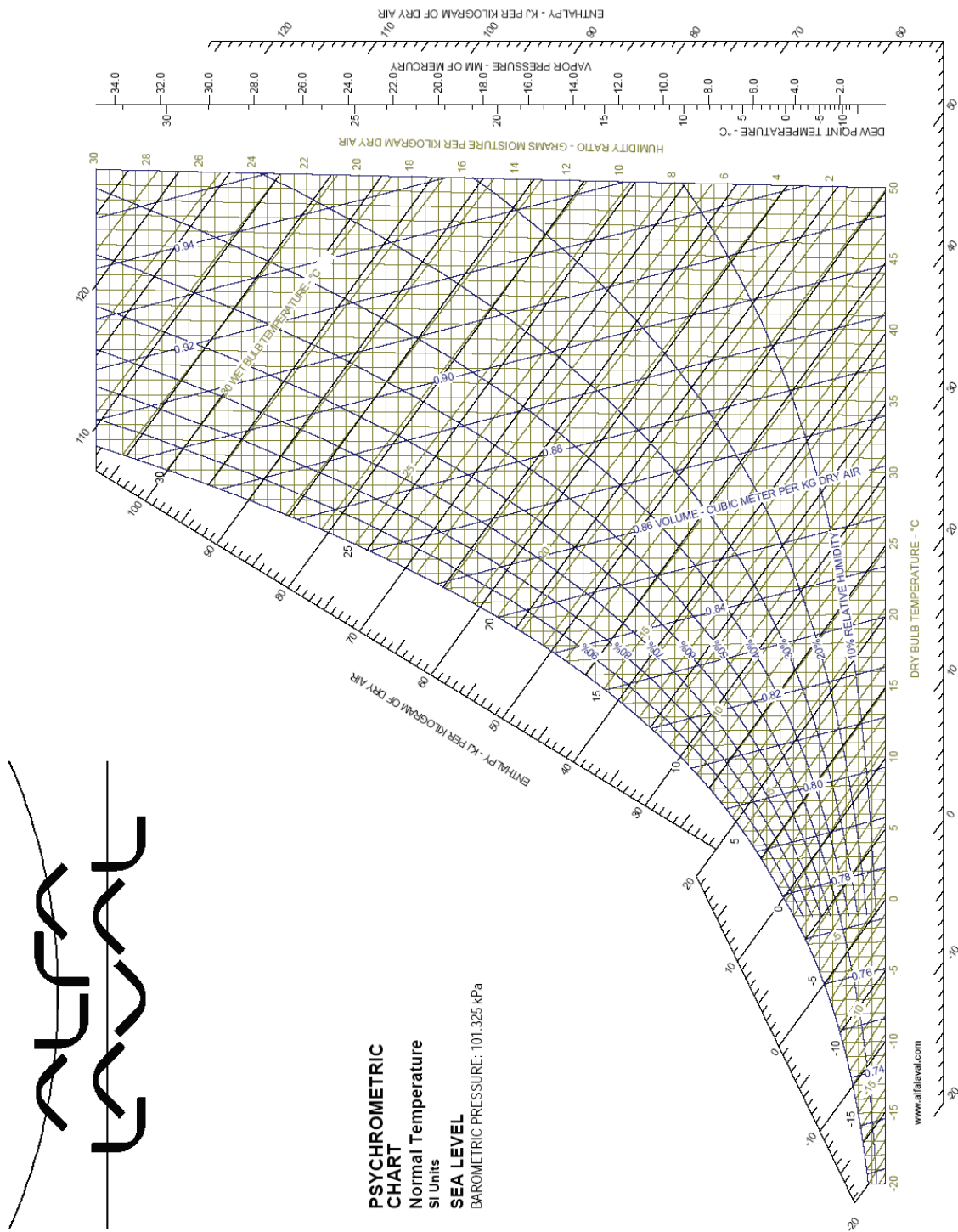

Water quality

With this kit only use water with the following characteristics:

pH: 6÷7

Hardness: 8 ÷ 12°F (80÷120ppm as CaCO3)

After 400 hours of use, the coil will show no signs of limestone or calcium deposits if this water is used.

The tube is also made of inox to avoid internal rust formation, particularly during periods of inactivity.

The pipe is developed to drain easily.

It is important to flux the pipeline with air during non-operative time, to avoid the risk of freezing.

NOTE

If use exceeds 400 hours a year, apply a suitable coil treatment (this can vary depending on surrounding conditions).

ATTENTION!

Always use a filter in the pipeline to prevent the deposit of dirt. Flux the pipeline with air to completely drain any excess water during periods of inactivity.

Service Instructions

ATTENTION!

Before starting service operations, make sure that the circuit is switched off! Problem-free operation of Spray Water Device adiabatic systems require regular service checks.

NOZZLE MAINTENANCE

The nozzles need regular maintenance in order to maintain their efficiency and prevent damage. We suggest making a first check after 5 hours of running before making future checks every 100 hours.

Pipeline Maintenance

Verify that the circuit is not occluded; this can occur when water quality is not at the desired level. We suggest making a first check after 10 hours of running before making future checks every 200 hours.

Drain to prevent ice formation.

If the ambient temperature is below zero, remember to drain the pipeline, to avoid the formation of ice.

Coil Cleanliness.

Follow the unit instruction manual when cleaning the coil (this should be carried out at least twice a year to prevent limestone formation).

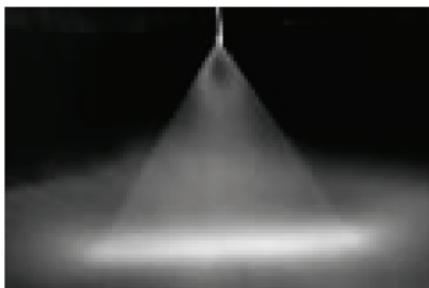

Spray from clean nozzle

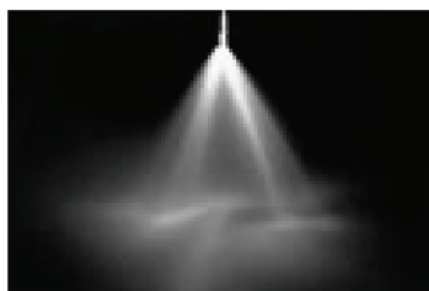

Distorted spray from damaged or clogged nozzle

AlfaStreamer

AlfaStreamer

Abstract

To describe the characteristics of a streamer used in air coolers. The streamer, a plug and play optional, provides the cooler with a higher air throw but without disadvantages like increased power consumption or noise levels. The Alfa Laval units tested show that the improvements are based upon an advanced velocity profile behind the fan by turning centrifugal velocity components in the axial direction.

Problem Definition

In large cold rooms, one problem is that heat can nest in the room. This is a result of the cold air volume flow being sucked back to the air inlet in a thermal short circuit. Where heat nests occur, it means part of the room is not as well conditioned or controlled. This could result in bad stock conservation due to the distance from conditioning source. Below is an example of a bad (red arrow) and good (blue arrow) airflow pattern in cold room field functionality



Air circulation and distribution is conditioned by the unit cooler used, (i.e. high fan diameter increases air throw), but it is also heavily influenced by the cold room conditions. In the next chapter, the thermodynamic properties that occur to modify the airflow into the cell are briefly described. Not all the variables reported below have a considerable negative effect on correct air circulation, but all have the ability to disrupt test field and consequently normal field functionality.

Theoretical variables of the ventilation system (cold room)

Air velocity and distribution efficiency is directly related to the fan used and is a function of air density, humidity, and altitude above sea level and the Coanda effect. All of these must be taken into consideration.

Air Density

The density of air varies with the air pressure and the altitude above sea level. It is possible to use the Ideal Gas Law (approximate method) to perform the calculation:

$$p V = m R T$$

with:

p = absolute pressure (N/m², lb/ft²)

V = volume (m³, ft³)

m = mass (Kg, lb)

R = individual gas constant (J/Kg.°K, ft.lb/slugs.°R)

T = absolute temperature (°K, °R)

This equation can be modified to:

$$p = \rho R T$$

where $\rho = m / V$

or better:

$$\rho_a = \frac{pM_a}{ZRT} \left[1 - x_v \left(1 - \frac{M_v}{M_a} \right) \right]$$

with:
p = absolute pressure (N/m², lb/ft²)
T = absolute temperature (°K, °R)
x_v = mole fraction of water vapour
M_a = molar mass of dry air
M_v = molar mass of water (18.015*10⁻³ Kg*mol⁻¹)
Z = compressibility factor
R = individual gas constant (J/Kg.°K, ft.lb/slugs.°R)

In practice, the mole fraction of water vapour **x_v** in moist air is not measured directly but is determined from the relative humidity **h** or from the temperature **td** of the dew point. The quantity **M_a** depends weakly on the mole fraction of carbon dioxide.

The air density is proportional to the absolute pressure. Being **H** pressure at a certain altitude, the ratio **H/H₀** decreases from 1 at sea level, to 0.74 at altitude 2,400m.

Temperature and relative humidity affects the air stream and consequently the air distribution. The typical cell condition in a refrigeration application is:

T_{cell} = -30°C / -40°C
 U.R. = 95%

NTP - Normal Temperature and Pressure, commonly used for testing and documentation of fan capacities is 20°C and 101.6kN/m² (60°F, 30 in Hg)

Coanda Effect

If the unit cooler is fitted close enough to a flat surface, usually the ceiling, the air stream will cling to the surface.

This is because the ambient air will be drawn into the stream, but close to the flat surface, where no new air can be drawn from above, a lower pressure is given; thus the stream is sucked close to the surface. This is known as the Coanda effect.

In a cold room where no isothermal air is given, a thermal energy, caused by differences in the air's density at different temperatures will force a cooler air stream downwards and a warmer air stream upwards.

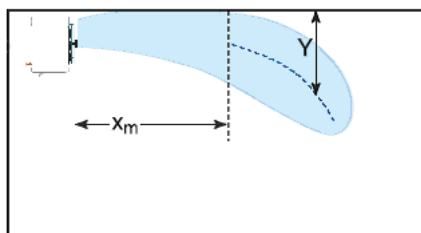

This means that two different forces affect a cooler stream that is sticking close to the ceiling: both the Coanda effect pushing it close to the ceiling and the thermal energy forcing it down towards the floor. At a given distance from the diffuser or valve outlet, the thermal energy will dominate and the air stream will eventually be pulled down from the ceiling. The stream's deflection and point of separation can be calculated using the formula based on the temperature differentials and the type of diffuser together with air velocities.

The air stream's point of separation (X_m) and deflection (Y).

The diffuser coefficient when the Coanda effect is influencing the air stream:

$$K_{corrected} = \sqrt{2 - K_{free\ flow}}$$

The horizontal discharge angle also increases to 30° when the stream is close to the ceiling, while the vertical angle remains unchanged (20-24°). The deflection from the ceiling to the central axis of the air stream (Y) can be calculated using:

$$Y = \sqrt{A_{eff}} * 0.0014 * \frac{\Delta t_o * \sqrt{A_{eff}}}{K * v_o^2} \left[\frac{x}{\sqrt{A_{eff}}} \right]^3$$

with:
Δ₀ = the temperature difference between the air stream and the ambient air
x = distance from the diffuser/valve [m]
v₀ = velocity at the diffuser/valve outlet [m/s]
K = the diffuser coefficient
A_{eff} = the diffuser or valve's effective outlet area [m²]

The point where a conical air stream leaves the ceiling (x_m) will be:

$$X_m = \frac{1.6 * K * v_0 * A_{eff}}{(A_{eff})^{0.75} * \sqrt{\Delta t_0}}$$

with:
 Δt_0 = the temperature difference between the air stream and the ambient air
 v_0 = velocity at the diffuser/valve outlet [m/s]
 K = the diffuser coefficient
 A_{eff} = the diffuser or valve's effective outlet area [m²]

Fans (key component)

Every fan must overcome the resistance occurring when taking the air through ducts, bends and other ventilation equipment. This resistance causes a fall in pressure, and the size of this fall is a decisive factor when choosing the dimensions of each individual fan. A fan's performance is proportional to its energy consumption.

Since density of air varies with temperature and air pressure (or altitude and elevation above sea level), when the operating conditions are outside NTP - Normal Temperature and Pressure conditions - a fan will not deliver according to manufacturing specification.

Manufacturers' specifications of fans are generally based on the NTP - Normal Temperature and Pressure Conditions - 20°C, 101.6kN/m², 1.204Kg/m³.

When all other variables are equal, a fan has to be considered as a "constant volume" device where the transported volume is always the same, regardless of air temperature or density. Only the mass flow through the fan varies with air temperature and air density.

- With hot air and lower air density => less mass will be taken through the fan
- With cold air and higher air density => more mass will be taken through the fan
- With equal speed and dimensions => the volume flow remains equal

The cold room is represented at second point: low temperature outlet from the unit cooler has a positive effect on the air stream, but a negative one on the air circulation (Coanda effect).

The effect of the air and temperature density variation on the fan's performance as previously described can be expressed as:

The ratio between volume flow at different temperatures: $q_1 / q_2 = (273 + t_2) / (273 + t_1)$

with:
 q = volume flow [m³/s]
 t = temperature [°C]

The ratio between power consumption at different temperatures: $P_1 / P_2 = (273 + t_2) / (273 + t_1)$

with:
 P = power consumption [W]

The ratios are expressed in the chart below:

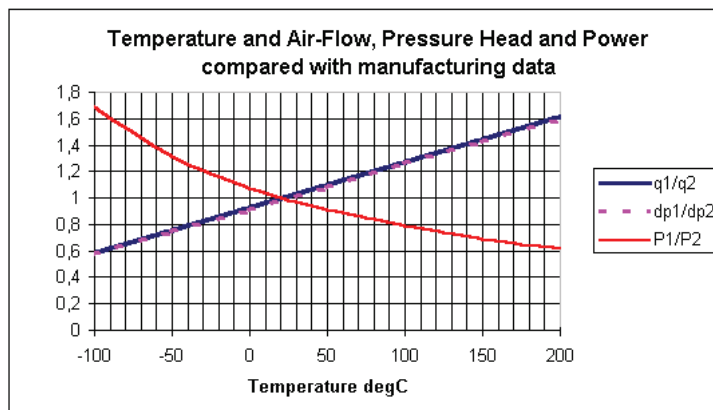

Air velocity

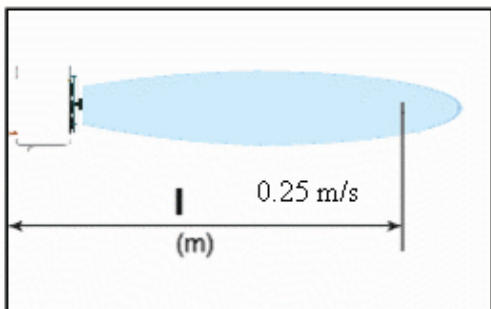

The air throw, defined by CECOMAF- standard GT6-001 and ENV 328 as the distance between the fan and the point on the rotation axis where the outflow velocity reaches a limit of 0.25m/s, is used as the main criterion. However, it must be considered that in industrial application the velocity limit should be 0.5 m/s. A throw of this type is designated by length (in the drawing below) and is measured in metres.

The air stream actually consists of several zones with different flow conditions and air velocities. The area of higher practical interest is the main section. The centre velocity, the velocity around the centre axis, is in inverse proportion to the distance from the fan. The air stream is fully developed in the main section, and here the prevailing conditions affect the flow conditions in the room the most as a whole.

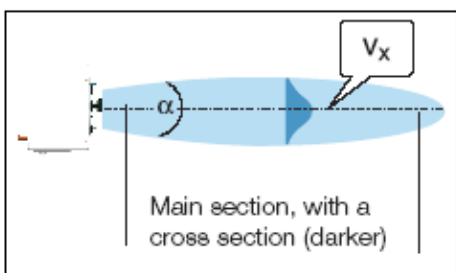

It is possible to mathematically calculate the air velocity in each part of the stream. To calculate the velocity at a particular distance from the diffuser or valve, it is necessary to know the air velocity at the fan's outlet, the shape of the diffuser/valve and the type of air stream produced by it.

The common formula used to calculate the distance reached by air stream in case of axial fans and unit with single airflow is:

$$\left(\frac{V_x}{V_o}\right) = m * \left(\frac{D_o}{x}\right)$$

with:
 m= air velocity coefficient,
 D_o= diameter of fan,
 V_x= air velocity at x distance from unit,
 V_o= outlet air velocity
 x= distance between unit axial fan and actual measurement point

The formula is not a function of temperature, pressure or relative humidity.

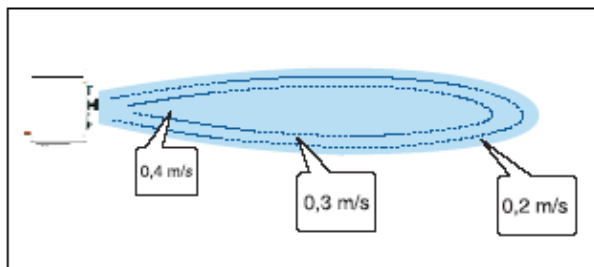

In the same way, it is also possible to see how the velocities vary in every cross section of the stream. Using these calculations as the starting point, velocity curves for the entire stream can be drawn. The areas having the same velocity can be easily determined. These areas are called isovels.

The velocity at the cross section of the air stream is:

$$\frac{V}{V_x} = \left[1 - \left(\frac{y}{0.3 * x} \right)^{1.5} \right]^2$$

with:
 V= vertical distance from the central axis [m]
 x= distance from the fan [m]
 V= velocity at distance y [m]
 V_x = centre velocity at distance x [m/s]

If the air velocity along the room is not enough to assure an optimal cold air distribution, the air stream will deflect and start looping.

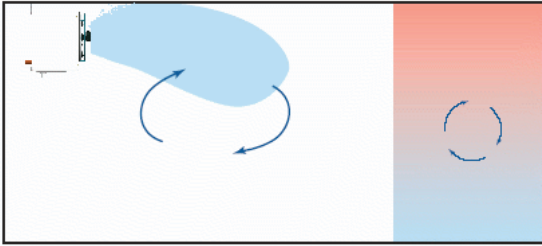

To avoid this effect you can:

- increase the number of cooling units.
- increase the rotational speed of the motor.
- use long textile socks.

All the proposed solutions have a negative impact on cost in terms of:

- Energy consumption
- pressure losses
- Noise level

an alternative and low cost solution is to modify the outflow velocity pattern of the fan by reducing the opening angle of the air stream. An efficient way to realise this effect is to turn the radial and centrifugal flow components in the axial direction.

Streamer field test

Alfa Laval investigated the real advantage of using streamers on its units during an internal laboratory test. The test field was first set according to the ENV 328. The second step involved modification to simulate the real effects of unit installation close to the ceiling in cold room conditions. The instruments used are calibrated according to the current requirement.

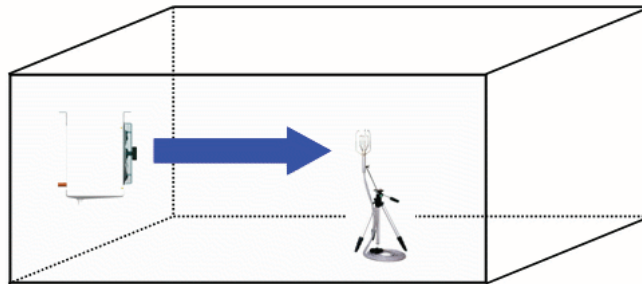

Using a digital anemometer, the air stream velocity was monitored at different distances from the fan. In addition to this test, a standard unit was tested as a control to verify the accuracy of data used in Alfa Laval's selection program. Two different units and conditions were tested, as described in the table below:

Alfa Laval Unit Fans mounted	INGE403C45E EBM A4D 400-AS 04-11	INRW504K60W(B) FE 050 VDA 4I 2NV
One Fan	√	√
Three Fans	√	√
One Fan with Streamer	√	√
Three Fans with Streamers	√	√
One 6-Pole Fan		√
One Fan Y wiring	√	
One Fan Y wiring with Streamer	√	

As reported, units with 400mm and 500mm fan diameters have been tested. The eleven tests performed give a complete set of data that are described briefly below.

Graph 1 plots the results of unit INGE403C45E (all fans running).

400 mm Fan Diameter

GRAPH1

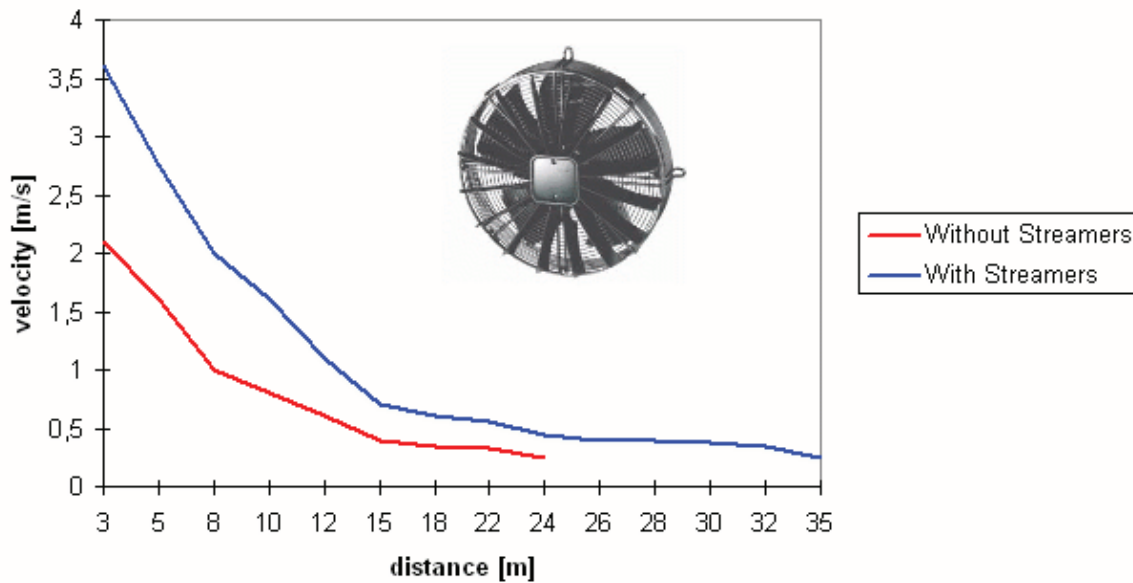

Plotted In red is the velocity of air of a standard unit, reached at different distances. As was expected, the velocity decreases with increased distance from the fan due to the mixing processes in the exhaust stream with other air in the room.

It's important to emphasise that the fan's performance and air throw changes when surrounding conditions change, as explained in the previous chapter. In cold rooms air throw will be longer, due to higher air density. The power consumption of fans can be estimated up to 2% higher than normal.

Plotted in blue is the air velocity of a unit which has been mounted with standard streamers. Its curve on the graph is similar to the red line, and again, this can be attributed to the mixing process.

Note that the limit velocity as ENV 328 rule (0.25m/s) is reached at 24m without streamers. With streamers it is possible to increase the air throw to 11m; with the streamer the limit velocity was reached at 35m.

Streamers mounted on units with 3 x 400mm fan diameters can increase the airflow from approximately 52%-60%.

The real increment depends on:

- Number of fan poles
- Number of unit fans
- Environmental conditions

The modification of the airflow pattern by the streamer is depicted below. The measurements show very clearly that the benefit of the streamer is caused by the concentration of the outflow stream of the cooler.

The graph on the right refers to a 350mm fan motor.

The red line represents the velocity profile behind the standard fan motor.

The blue line is the characteristic profile achieved using a streamer.

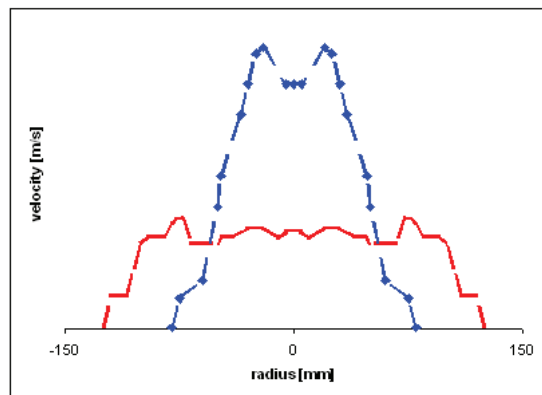

Graph 2 plots the results of unit INRW503K60W(B). Note that the limit velocity as ENV 328 rule (0.25m/s) is reached at 24 m without streamers. With streamers it is possible to increase the air throw to 11 m; with the streamer the limit velocity was reached at 35m.

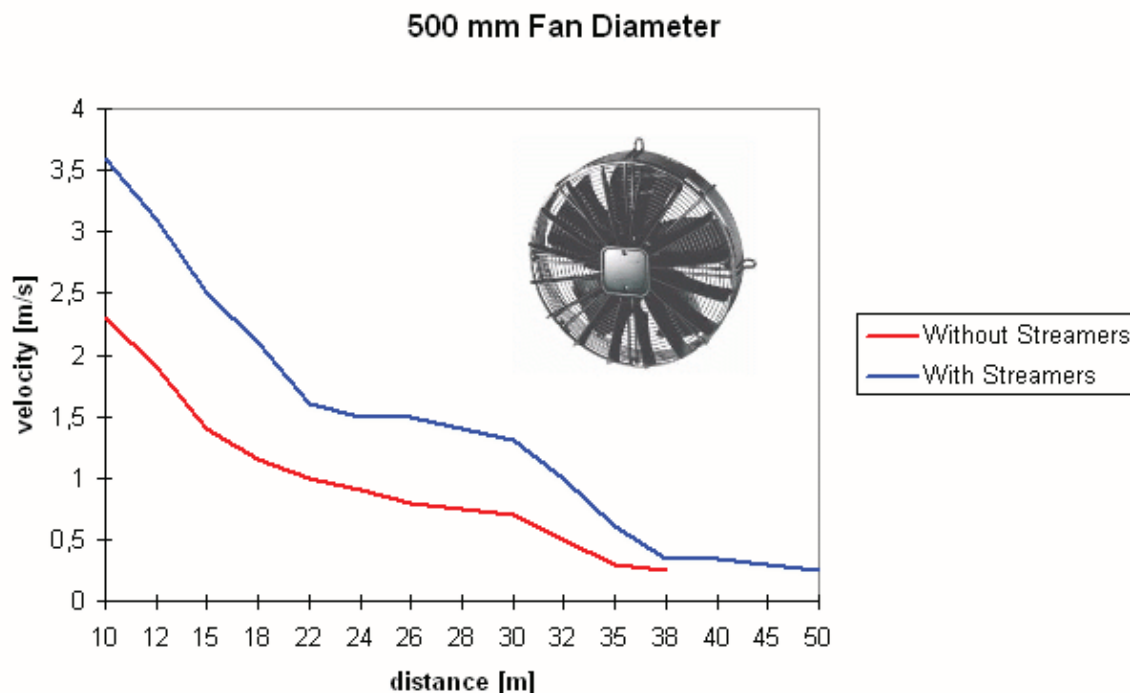

When the limit velocity is considered equal to 0.5m/s (refrigeration applications), the benefit is obvious. It's 32 m without streamers, with streamers it's possible to increase the air throw of 8 m; with streamer the limit velocity is reached at 38 m.

In blue is plotted the velocity of air of a unit which mounts the standard streamers. As in the Graph1 performance runs in similar way, but the gap between standard model and model with streamer is higher on diameter 500 mm than diameter 400 mm. It's because the effect/performance of streamer is function of fan power. Streamers mounted on units with 3 x 500mm diameter fans can increase the relative velocity airflow by approximately 54%-68%.

The reported values have been obtained in the field without the occurrence of the Coanda effect. The Coanda effect on performance is negative, and strictly depends on cold room layout and environmental conditions. However, it is possible to estimate the percentage performance decrease of streamers at below 5%. It can be demonstrated that the streamer helps to minimise the Coanda effect. As a result of the high airflow velocity, the under pressure force is balanced.

As in the previous test, streamers caused no increase in noise levels.

Conclusion

Streamers are a plug-and-play option which can be clipped onto the guard grill. Durability has been tested at several temperatures (-40°C / +60°C) and environmental conditions.

Rounded and closed contours which minimise dirt deposit, make this a suitable option for pharmaceutical applications. Using the streamer, it becomes possible to achieve a uniform airflow through cold storage, without increasing the number of units installed, or the air volume to be cooled. It is possible to prevent warm air circulation without energy or maintenance costs.

Tests performed by Alfa Laval have demonstrated the efficiency of this new accessory. Graph 3 plots the results adapted for a range of unit coolers developed by Alfa Laval.

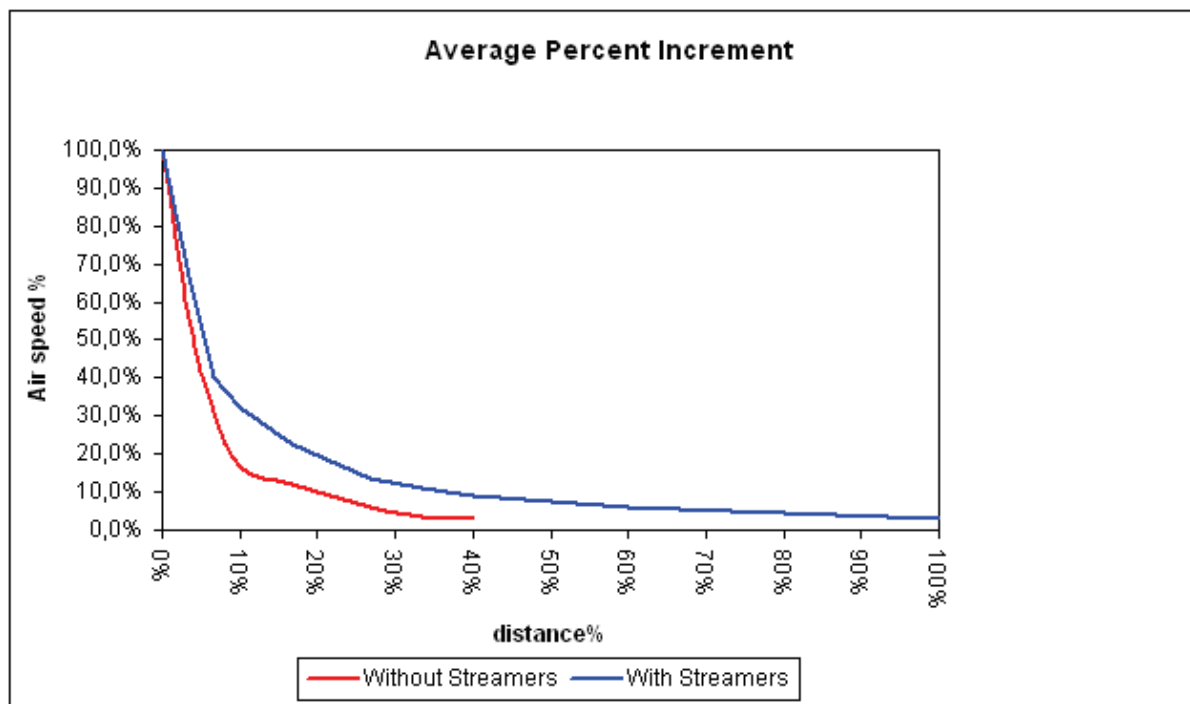

Graph 3

Benefit of Streamers

- Concentration of the outflow stream in axial direction.
- Uniform and high efficient cooling of large rooms.
- No energy losses
- No fan efficiency performance disruption.
- No noise
- Easy installation