

Data Sheet Ice Bank-, Ice Difference- and Liquid Level Controller

EE 37-1201
EE 37-1203
EE 37-1204

No. 5310079-00/00E

Short Description

The electronic controller EE 37-120x controls the filling level of electrically conductive liquids. The function principle is to measure the conductivity of a liquid between electrodes. To avoid electrolytic problems in the liquid, alternating current is used for measuring.

The following applications are possible:

- Flow Indicator in Pipelines
- High water mark Indicator
- Dry Operation Protection
- Ice-Accretion Difference Controller in ice storage plants
- Ice-Accretion Controller
- Compressor switching for ice banks



Ice-Accretion Difference Controller

Three electrodes enables control of ice accretion between minimum and maximum thus providing a better operation/rest ratio in large-scale plants and increasing their longevity.

Level Controller

In this case the 'common' electrode can be connected to the ground connection of the container. Its function is similar to the ice-accretion difference controller.

Technical Data

Supply Voltage	EE 37-1201	230 V, 50...60 Hz
	EE 37-1203	42 V, 50...60 Hz
	EE 37-1204	115 V, 50...60 Hz
Power Consumption	ca.	1,5 VA
Contact Rating	10 A cos phi = 1	
	4 A ind. /250 VAC	
Ambient Temperature	-20...+60 °C	
Voltage at Electrodes	appr.	10V~
Mounting	by screws	
Electrical Connection	6,3/4,8mm flat plugs	

Application Example Level Control

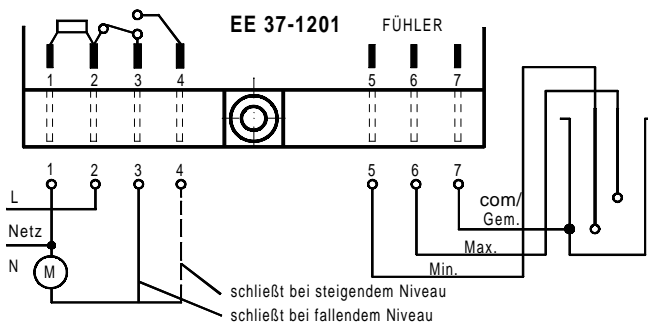

The 'common' electrode is connected to the 'ground' connection of the metallic container or an evaporator coil. When there is no liquid in the container, the relay starts the containers fill-pump. If the liquid reaches the maximum electrode, the pump stops. The relay switches on again when the minimum electrode has no longer contact with the liquid.

Application Example Ice-Accretion Control

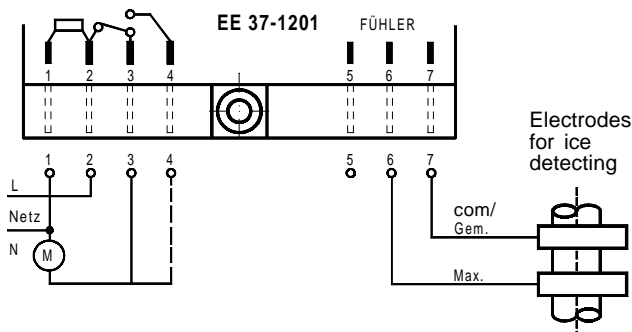

Application Example Ice-Accretion Difference Control

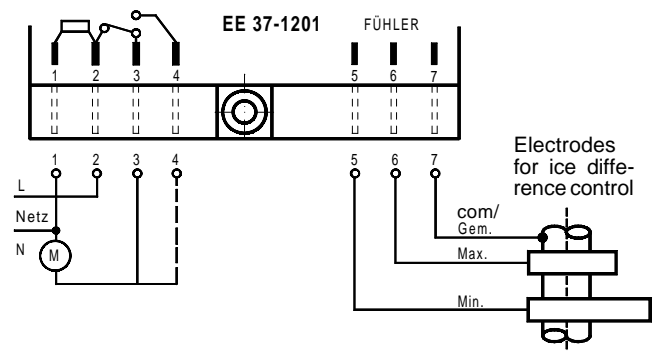

Dimensions / Connections

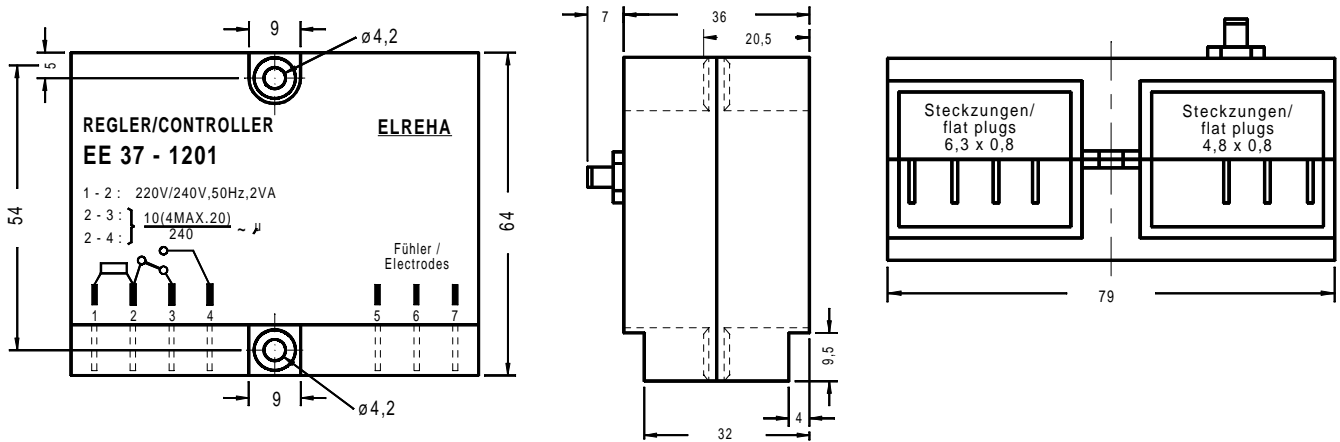

Accessories

Electrodes are used for liquid level or ice level controllers whose principle is based on the measuring of the liquids conductivity. The outlines and the material of electrodes depend on the application, they will be manufactured by the customer mostly.

We can offer you the following type:

- Elektrodes **L56-3001** (3 poles) for mounting on evaporator coils.

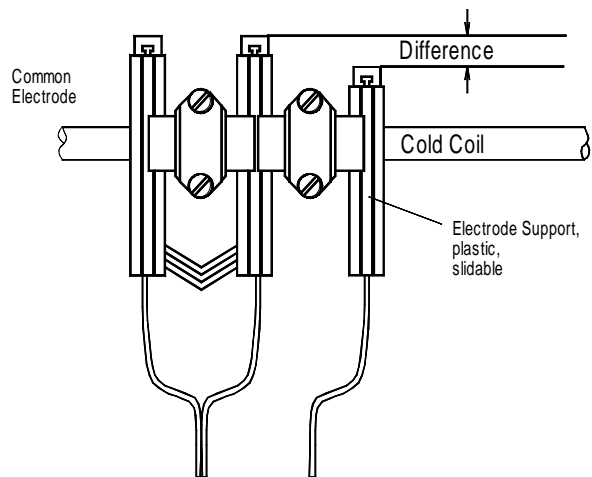

EG-Statement of Conformity



We state the following: When operated in accordance with the technical manual, the criteria have been met that are outlined in the guidelines of the council for alignment of statutory orders of the member states on electro-magnetic consistency (89/336/EWG). This declaration is valid for those products covered by the technical manual which itself is part of the declaration. Following standards were consulted for the conformity testing with regard to electromagnetic consistency :

**IEC 1000-4-1, IEC 1000-4-2, IEC 1000-4-3*, IEC 1000-4-4, IEC 1000-4-5,
EN 55011 B, EN 50081, part 1 and 2; EN 50082, part 1 and 2**

This statement is made from the manufacturer / importer
ELREHA Elektronische Regelungen GmbH
68766 Hockenheim
 (Name / Anschrift / name / adress)

by:
**Klaus Birkner, Development and
 and leader of the EMC-Laboratory**

Hockenheim
 Ort/city

28.6.1996
 Datum/date

[Signature]
 Unterschrift/sign

*The conformity with IEC 1000-4-3 is derived from the IEC 1000-4-2 and IEC 1000-4-4 test results. The correlation with IEC 1000-4-3 is based on test results which are located on site at the manufacturer.

This manual has been set up with care, but mistakes are still possible. Technical details can be changed without notice. If there are still problems or difficulties or questions please don't hesitate asking our technical support.

set-up:	22.2.99	checked:	22.2.99	approved:	22.2.99
by:	tkd/jr	by:	mv/mh	by:	mv/sha