



V-SHAPE CONDENSER COMPACT LINE – ACW
R134A / R404A / R507 / R22

RCP Reinforced Cabero Profile
STES Safety Tube Expansion System
Energy Efficiency Classes
Smooth Fins





OUR ADVANCE TECHNOLOGY FOR YOUR APPLICATION BENEFITS AND OPERATION SECURITY

CASING

The casing is made of zinc plated sheets, painted in RAL 7035 (light grey) in a high temperature process. Strict controlling of exactness and quality is the most characteristic mark of our sheet metal processing. All components are painted before assembling and guaranteed the customer that all edges are painted (corrosion is avoid) and the finish of the units are in a high performance.

ADVANTAGES: no corrosion, precise and optimal finishing, better good looking



RCP REINFORCED CABERO PROFILE

The new RCP guaranteed the customer by finned lengths over 4200 mm a self supporting casing structure with an neglect able on flexion and torsion during the different steps of transport, lifting or not plan set up places. The advantages of RCP are that the unit has more rigidity and fewer feet and therefore fewer foundations are required. A less roof load due to reduced unit weight is also one of the new favourable features of the new design.

ADVANTAGES: better distribution of weight especially for the side panels, the coil remains straight even after long operation time unburdening of rivets and screws solid and rigid long lasting construction

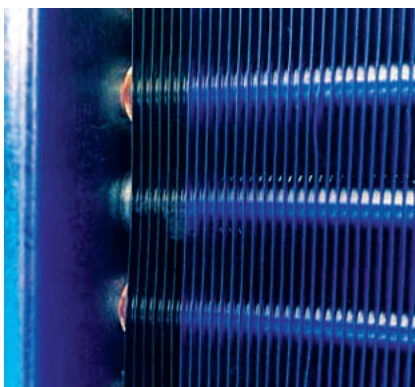

TUBES AND FINNS

The use of high quality material for our tubes with a sufficient thickness is obligatory for our products. This is one of the most important points to achieve a high reliability are permanent expansion and shortening.

The standard fins are made in aluminium. Furthermore we offer specially coated fins showing a high resistance towards aggressive environmental influences. On our purpose we don't recommend for outside application the called "turbo or optimized" fins. According to our knowledge and experience such a fin surface is sooner or later irreversible blocked with dirt.

A constant in significant lost of the capacity in spite of cleaning is the natural consequences. We will take the opportunity and announce that the described fins are used by well known manufactures.

Of reason of price we will offer this fins on special on demand. Nevertheless it will become the standard fins of our heat exchanger. It is a possibility for our customer to pay less for same capacity. We want the point explicit at the definitely higher fouling factor of these hard clean fins. A responsibility for this fact could never bring to us especially after a significant capacity loss caused by the explained process.

ADVANTAGES: long term operation, relative low fouling factor of the fins, constant and stabile operation because of smooth fins





STES SAFETY TUBE EXPANSION SYSTEM

Due to the thermal expansion of the tubes, the tubes couldn't get in contact with any metal sheet. This is one of the principle features of the new STES. In combination with our rigidity RCP structure keeps the coils absolutely straight to allow a free movement of the tubes in horizontal direction and based on the floating coil, the STES provides the customer the highest operation security and prevents a leakage during operation caused by friction of the tubes.

ADVANTAGES: long lasting heat exchanger, movable coil

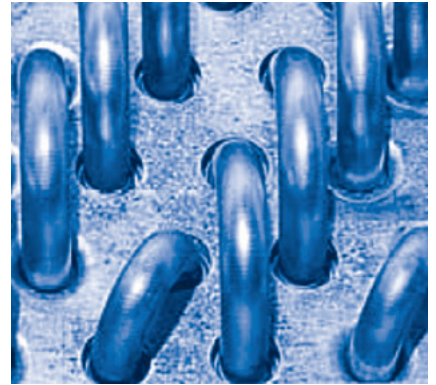

CERTIFICATION OF FANS AND ENERGY LABEL

To keep profound certainty concerning the technical performance also in practice, the improved sound graduation of the CABERO condensers guarantees maximum compliance with noise regulations. The definition in different energy classes guaranteed the customer a high performance. The noise pressure was tested according to DIN 45635 / 1 and DIN EN23741. All fans of our standard series are bold according to DIN 40050 (for 400V). The calculation of the mentioned noise pressure levels of our units is based on the standards and definition for noise pressure level mentioned in our technical supplement.

We reserve the right to use fans from different manufacturers. For the corresponding electrical data please refer to the nameplate. In case of higher air temperatures and varying air resistance the power consumption will change. The integral thermo contacts must be used as motor protection for warranty reason.



CAPACITY CERTIFICATION OF AIR COOLED CONDENSERS AND DRY COOLERS

To keep profound certainty concerning the technical performance also in practice, several units were tested by the recognized and approved neutral test institute the TÜV Bavaria / Saxony. The testing norms and procedure was for condensers according to EN327 and for dry coolers according to EN1049. Both testing norms will be also applied as base for the testing brand EUROVENT. The results of the tests were the fundamental parameters for the calculation of our software.

ADVANTAGES: designing security, operation security



QUALITY CONTROL IN FACTORY

All components are strictly tested and screened before assembling. To minimize the possibility of a defect, there are quality checks after each processing stage. Each coil is pressure tested according to their operation application between 12 and 36 bar and charged after this procedure in a light overpressure for transport reasons with nitrogen or dry air. The final examination contains furthermore the check for completeness and as far as possible for function.

ADVANTAGES: no corrosion, precise and optimal finishing, better good looking

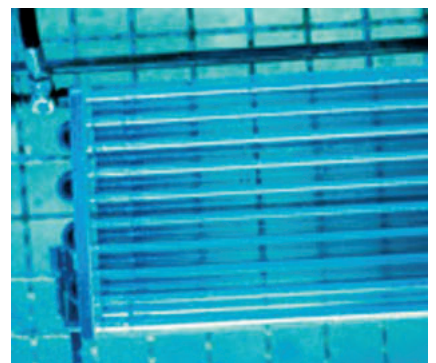

THE ADVANTAGES AND THE ACCESSORIES OF THE NEW ACW / GCW AT A GLANCE



- Capacities from 76 kW to 1,700 kW in the smallest possible mounting area
- For all coolants as well as ammonia, CO₂, glycol or other substances requiring cooling
- Tubes constructed of stainless steel, copper or aluminium / fins made of Al, AlMg, coated versions, etc.
- 16 different sound-level classes, from 68 dB(A) to 31 dB(A) at ten metres
- Compact design: approx. 70 % more power in relation to former floor space occupied 1,140 mm wide, up to 1,900 mm high and 8,800 mm long (lower refrigerant charge, lower transportation costs, lower installation dimension)
- Weight reduction thanks to the use of new materials, while at the same time the RCP (Reinforced CABERO Profile) continues to provide excellent resistance to torsion and deformation
- Can be equipped or postequipped with adiabatic technology by fitting our, blue fin coils together with a complete control system
- The proven STES system (Safety Tube Expansion System) helps prevent wear on the tubes caused by the coolant or medium
- Powder-coated surfaces
- In order to ensure a constant and proper air supply, it is necessary to mount the units on a substructure when applying a double row or multiple row line-up. The frame construction system (substructure) that is also supplied ex-works (as an accessory) permits mounting at a height of up to two metres when two units are placed alongside each other (W-shaped construction). This saves you a large part of the cost of having an expensive frame construction built as well as having to obtain building permission and undertake time-consuming construction work, all of which are currently necessary for our competitors.
- The fins are as smooth execution as can be expected, given their outdoor application and degree of fouling (good provision has been made for cleaning, no great drop in capacity when the fins are fouled to a normal degree, etc.)
- Utilisation of fans optimised to use as little energy as possible (energy saving), available in protection classes IP 54 or IP 66
- High-temperature or explosion-proof fans can be used
- Standardised list of accessories such as motor protection units, repair switches, control technology, speed controllers, anti-vibration mountings, flanges, etc.



DEFINITIONS:

NOISE PRESSURE LEVEL DEFINITION:

The noise pressure level per gauging surface with reference to the cuboids surface at 5 m distance from the unit in open air over a not reflecting plain according EN13487. Speed change, start up and control noises are not taken into account. The result can only be seen as a standard or reference value. The actual noise pressure level must be determined with the sound power by considering all influences at the location of the unit.

CAPACITY:

The capacity indications are valid for R404a. The nominal capacities refer to condensing temperature $t_c = 40\text{ }^\circ\text{C}$, air inlet temperature $t_{a1} \square t_{sur} = 25\text{ }^\circ\text{C}$, temperature difference $\Delta t = 15\text{ K}$, hot gas superheating of $\Delta t_h = 25\text{ K}$, geodetic height NN. Measurements are also in accordance with EN327 and EN13487 standards (noise level data).

We recommend that you use our software package CC 2007 for a reliable thermodynamic design in existing conditions (also for other refrigerants, geodetic heights and blue or coated fins).

capacity	in kW	0–36	36–48	48–74	74–116	116–190	190–284	284–466	466–648	648–1296
inlet	in Ø mm	2x16	2x18	2x22	2x28	2x35	2x42	2x54	2x64	4x64
outlet	in Ø mm	2x16	2x18	2x22	2x28	2x35	2x42	2x54	2x64	4x64

F1 Correction factor for delta t

Delta t in °C	8	9	10	11	12	13	14	15	16	17	18
F1	1.78	1.56	1.44	1.32	1.22	1.12	1.06	1.00	0.95	0.85	0.85

F2 Correction factor for different air inlet temperature

Air inlet in °C	10	15	20	25	30	35	40	45
F2	0.951	0.967	0.963	1.00	1.017	1.034	1.025	1.145

F3 Correction factors for other refrigerants acc. EN327 (applied by Eurovent or TÜV)

Refrigerant	R507	R404a	R22	R134a	R407c
F3	1.00	1.00	1.041	1.075	1.12

F4 Correction factors for different places of set up

Over sea level in mm	0	500	1000	1500	2000	2500
F4	1.00	1.04	1.08	1.12	1.18	1.25

F5 Correction factors (f_m) for other fin materials acc. EN327 (applied by Eurovent or TÜV)

Fin material	Aluminium	Blue fin	Coated Aluminium (EPOXY)	Cooper
f_m factor	1.00	1.006	1.03	0.97

Model					Capacity		Air volume		Noise pressure level		Fan data			Dimensions				
Fan diameter	rows specification	fin pitch specification	heat exchanger spec.	quantity of fan(s)	fan specification	condensing temperature: 40 °C	Delta T: 15 K	refrigerant: R404a	Density 1.2 kg/m ³	Distance: 10 m	Norm: EN 13487	empty weight	tube volume	exchange surface	length L	width B	height H	No. of feet
09	5	A	2.2/2	CN	186144	168896	63800	54800	61	55	n = 890 rpm / 700 rpm I = 7.2 A / 4.3 A P = 3600 W / 2500 W Delta/star	558	75	429	2360	1120	1950	2
09	7	A	2.2/2	CN	216384	193536	62700	53400	61	55		613	100	571	2360	1120	1950	2
09	9	A	2.2/2	CN	232288	207760	61800	52200	61	55		669	125	714	2360	1120	1950	2
09	5	A	3.3/3	CN	278099	252584	95700	82200	63	57		756	112	644	3460	1120	1950	2
09	7	A	3.3/3	CN	323278	289433	94050	80100	63	57		839	150	857	3460	1120	1950	2
09	9	A	3.3/3	CN	347038	310705	92700	78300	63	57		921	187	1071	3460	1120	1950	2
09	5	A	4.4/4	CN	370799	336441	127600	109600	64	58		1075	150	858	4560	1120	1950	3
09	7	A	4.4/4	CN	431037	358524	125400	106800	64	58		1182	200	1142	4560	1120	1950	3
09	9	A	4.4/4	CN	462718	413858	123600	104400	64	58		1294	250	1428	4560	1120	1950	3
09	5	A	5.5/5	CN	463499	420129	159500	137000	65	59		1230	187	1073	5660	1120	1950	3
09	7	A	5.5/5	CN	538796	481421	156750	133500	65	59		1504	250	1428	5660	1120	1950	3
09	9	A	5.5/5	CN	578397	516803	154500	130500	65	59		1639	312	1785	5660	1120	1950	3
09	5	A	6.6/6	CN	557315	503648	191400	164400	66	60		1616	225	1287	6760	1120	1950	4
09	7	A	6.6/6	CN	646555	577124	188100	160200	66	60		1781	300	1713	6760	1120	1950	4
09	9	A	6.6/6	CN	694077	619540	185400	156600	66	60		1943	374	2142	6760	1120	1950	4
09	5	A	7.7/7	CN	648898	587589	223300	191800	66	60		1759	262	1502	7860	1120	1950	4
09	7	A	7.7/7	CN	754315	673312	219450	186900	66	60		1951	350	1999	7860	1120	1950	4
09	9	A	7.7/7	CN	809756	722797	216300	182700	66	60		2141	437	2499	7860	1120	1950	4
09	5	A	8.8/8	CN	741598	670855	255200	219200	67	61		2083	300	1716	8960	1120	1950	4
09	7	A	8.8/8	CN	862074	768725	250800	213600	67	61		2300	400	2284	8960	1120	1950	4
09	9	A	8.8/8	CN	925435	825223	247200	208800	67	61	2518	499	2856	8960	1120	1950	4	

Model					Capacity		Air volume		Noise pressure level		Fan data			Dimensions				
Fan diameter	rows specification	fin pitch specification	heat exchanger spec.	quantity of fan(s)	fan specification	condensing temperature: 40 °C	Delta T: 15 K	refrigerant: R404a	Density 1.2 kg/m ³	Distance: 10 m	Norm: EN 13487	empty weight	tube volume	exchange surface	length L	width B	height H	No. of feet
09	5	A	2.2/2	CL	163576	142352	56200	42200	53	49	n = 680 rpm / 520 rpm I = 3.4 A / 2.3 A P = 1750 W / 1200 W Delta/star	558	75	429	2360	1120	1950	2
09	7	A	2.2/2	CL	183904	157472	49200	40300	53	49		613	100	571	2360	1120	1950	2
09	9	A	2.2/2	CL	199920	167216	48100	37800	53	49		669	125	714	2360	1120	1950	2
09	5	A	3.3/3	CL	244383	212887	84300	63300	54	50		756	112	644	3460	1120	1950	2
09	7	A	3.3/3	CL	274753	235499	73800	60450	54	50		839	150	857	3460	1120	1950	2
09	9	A	3.3/3	CL	298680	250072	72150	65700	54	50		921	187	1071	3460	1120	1950	2
09	5	A	4.4/4	CL	325843	283565	112400	84400	55	51		1075	150	858	4560	1120	1950	3
09	7	A	4.4/4	CL	366337	313684	98400	80600	55	51		1182	200	1142	4560	1120	1950	3
09	9	A	4.4/4	CL	398241	333094	96200	75600	55	51		1294	250	1428	4560	1120	1950	3
09	5	A	5.5/5	CL	407304	354101	140500	105500	56	52		1230	187	1073	5660	1120	1950	3
09	7	A	5.5/5	CL	457921	391712	123000	100750	56	52		1504	250	1428	5660	1120	1950	3
09	9	A	5.5/5	CL	497801	415950	120250	94500	56	52		1639	312	1785	5660	1120	1950	3
09	5	A	6.6/6	CL	489747	424494	168600	126600	57	53		1616	225	1287	6760	1120	1950	4
09	7	A	6.6/6	CL	549505	469582	147600	120900	57	53		1781	300	1713	6760	1120	1950	4
09	9	A	6.6/6	CL	597361	498638	144300	113400	57	53		1943	374	2142	6760	1120	1950	4
09	5	A	7.7/7	CL	570226	495243	196700	147700	57	53		1759	262	1502	7860	1120	1950	4
09	7	A	7.7/7	CL	641089	547845	172200	141050	57	53		1951	350	1999	7860	1120	1950	4
09	9	A	7.7/7	CL	696921	581744	168350	132300	57	53		2141	437	2499	7860	1120	1950	4
09	5	A	8.8/8	CL	651687	565422	224800	168800	58	54		2083	300	1716	8960	1120	1950	4
09	7	A	8.8/8	CL	732674	625479	196800	161200	58	54		2300	400	2284	8960	1120	1950	4
09	9	A	8.8/8	CL	796481	664182	192400	151200	58	54	2518	499	2856	8960	1120	1950	4	

Model					Capacity		Air volume		Noise pressure level		Fan data			Dimensions					
Fan diameter	rows specification	fin pitch specification	heat exchanger spec.	quantity of fan(s)	fan specification	condensing temperature	temperature: 40 °C	Delta T: 15 K	refrigerant: R404a	Density 1.2 kg/m ³	Distance: 10 m	Norm: EN 13487	empty weight	tube volume	exchange surface	length	width	height	No. of feet
																in mm	in mm	in mm	quantity
						Delta in W	Star in W	Delta in m ³ /h	Star in m ³ /h	Delta in dB(A)	Star in dB(A)		in kg	in liter	in m ²	in mm	in mm	in mm	
09	5	A	2.2/2	S		127568	107632	35800	27600	45	37					2360	1120	1950	2
09	7	A	2.2/2	S		142576	116816	34200	26400	45	37					2360	1120	1950	2
09	9	A	2.2/2	S		154560	121744	33400	25400	45	37					2360	1120	1950	2
09	5	A	3.3/3	S		190587	160964	53700	41400	47	39					3460	1120	1950	2
09	7	A	3.3/3	S		213009	174698	51300	39600	47	39					3460	1120	1950	2
09	9	A	3.3/3	S		230913	182068	50100	38100	47	39					3460	1120	1950	2
09	5	A	4.4/4	S		254115	214403	71600	55200	48	40					4560	1120	1950	3
09	7	A	4.4/4	S		284011	232697	68400	52800	48	40					4560	1120	1950	3
09	9	A	4.4/4	S		307884	242514	66800	50800	48	40					4560	1120	1950	3
09	5	A	5.5/5	S		317644	267735	89500	69000	49	41					5660	1120	1950	3
09	7	A	5.5/5	S		355014	290580	85500	66000	49	41					5660	1120	1950	3
09	9	A	5.5/5	S		384854	302838	83500	63500	49	41					5660	1120	1950	3
09	5	A	6.6/6	S		381939	320959	107400	82800	50	42					6760	1120	1950	4
09	7	A	6.6/6	S		426017	348345	102600	79200	50	42					6760	1120	1950	4
09	9	A	6.6/6	S		461825	363041	100200	76200	50	42					6760	1120	1950	4
09	5	A	7.7/7	S		444702	374452	125300	96600	50	42					7860	1120	1950	4
09	7	A	7.7/7	S		497020	406403	119700	92400	50	42					7860	1120	1950	4
09	9	A	7.7/7	S		538796	423547	116900	88900	50	42					7860	1120	1950	4
09	5	A	8.8/8	S		508231	427514	143200	110400	51	43					8960	1120	1950	4
09	7	A	8.8/8	S		568023	463993	136800	105600	51	43					8960	1120	1950	4
09	9	A	8.8/8	S		615767	483567	133600	101600	51	43					8960	1120	1950	4

Delta/star P = 700 W / 4400 W I = 1.75 A / 0.85 A n = 440 rpm / 340 rpm

Model					Capacity		Air volume		Noise pressure level		Fan data			Dimensions					
Fan diameter	rows specification	fin pitch specification	heat exchanger spec.	quantity of fan(s)	fan specification	condensing temperature	temperature: 40 °C	Delta T: 15 K	refrigerant: R404a	Density 1.2 kg/m ³	Distance: 10 m	Norm: EN 13487	empty weight	tube volume	exchange surface	length	width	height	No. of feet
																in mm	in mm	in mm	quantity
						Delta in W	Star in W	Delta in m ³ /h	Star in m ³ /h	Delta in dB(A)	Star in dB(A)		in kg	in liter	in m ²	in mm	in mm	in mm	
09	5	A	2.2/2	E		111328	81760	29200	18400	42	32					2360	1120	1950	2
09	7	A	2.2/2	E		122752	85680	28100	17400	42	32					2360	1120	1950	2
09	9	A	2.2/2	E		127680	86464	26900	16200	42	32					2360	1120	1950	2
09	5	A	3.3/3	E		166324	122272	43800	27600	44	34					3460	1120	1950	2
09	7	A	3.3/3	E		183391	128134	42150	26100	44	34					3460	1120	1950	2
09	9	A	3.3/3	E		190754	129307	40350	24300	44	34					3460	1120	1950	2
09	5	A	4.4/4	E		221765	162866	58400	36800	45	35					4560	1120	1950	3
09	7	A	4.4/4	E		244522	170675	56200	34800	45	35					4560	1120	1950	3
09	9	A	4.4/4	E		254339	172236	53800	32400	45	35					4560	1120	1950	3
09	5	A	5.5/5	E		277207	203378	73000	46000	46	36					5660	1120	1950	3
09	7	A	5.5/5	E		305652	213129	70250	43500	46	36					5660	1120	1950	3
09	9	A	5.5/5	E		317923	215079	76250	40500	46	36					5660	1120	1950	3
09	5	A	6.6/6	E		333316	243808	87600	55200	47	37					6760	1120	1950	4
09	7	A	6.6/6	E		366783	255498	84300	52200	47	37					6760	1120	1950	4
09	9	A	6.6/6	E		381508	257836	80700	48600	47	37					6760	1120	1950	4
09	5	A	7.7/7	E		388089	284443	102200	64400	47	37					7860	1120	1950	4
09	7	A	7.7/7	E		427913	298081	98350	60900	47	37					7860	1120	1950	4
09	9	A	7.7/7	E		445092	300808	94150	56700	47	37					7860	1120	1950	4
09	5	A	8.8/8	E		443531	324751	116800	73600	48	38					8960	1120	1950	4
09	7	A	8.8/8	E		489044	340321	112400	69600	48	38					8960	1120	1950	4
09	9	A	8.8/8	E		508677	343435	107600	64800	48	38					8960	1120	1950	4

Delta/star P = 550 W / 270 W I = 1.1 A / 0.55 A n = 390 rpm / 250 rpm

Model					Capacity		Air volume		Noise pressure level		Fan data			Dimensions				
Fan diameter	rows specification	fin pitch specification	heat exchanger spec. quantity of fan(s)	fan specification	condensing temperature temperature: 40 °C Delta T: 15 K refrigerant: R404a		Density 1.2 kg/m ³		Distance: 10 m Norm: EN 13487		empty weight	tube volume	exchange surface	length L	width B	height H	No. of feet	
					Delta in W	Star in W	Delta in m ³ /h	Star in m ³ /h	Delta in dB(A)	Star in dB(A)								in kg
08	5	A	2.2/2	N	151088	125604	46540	35500	52	45	n = 880 rpm / 660 rpm I = 4.0 A / 2.3 A P = 2000 W / 1250 W Delta/star	537	75	479	2360	1120	1950	2
08	7	A	2.2/2	N	171808	143136	45200	34600	52	45		592	100	639	2360	1120	1950	2
08	9	A	2.2/2	N	188944	154560	44300	34100	52	45		648	125	799	2360	1120	1950	2
08	5	A	3.3/3	N	225725	187840	69810	53250	54	47		725	112	719	3460	1120	1950	2
08	7	A	3.3/3	N	256681	214060	67800	51900	54	47		807	150	958	3460	1120	1950	2
08	9	A	3.3/3	N	282282	231144	66450	51150	54	47		889	187	1198	3460	1120	1950	2
08	5	A	4.4/4	N	300967	250202	93080	71000	55	48		1033	150	958	4560	1120	1950	3
08	7	A	4.4/4	N	342242	285127	90400	69200	55	48		1140	200	1278	4560	1120	1950	3
08	9	A	4.4/4	N	376376	307884	88600	68200	55	48		1252	250	1597	4560	1120	1950	3
08	5	A	5.5/5	N	376209	312439	116350	88750	56	49		1177	187	1198	5660	1120	1950	3
08	7	A	5.5/5	N	427802	356051	113000	86500	56	49		1451	250	1597	5660	1120	1950	3
08	9	A	5.5/5	N	470471	384468	110750	85250	56	49		1587	312	1997	5660	1120	1950	3
08	5	A	6.6/6	N	452357	374550	139620	106500	57	50		1553	225	1438	6760	1120	1950	4
08	7	A	6.6/6	N	513362	426832	135600	103800	57	50		1718	300	1917	6760	1120	1950	4
08	9	A	6.6/6	N	564565	460898	132900	102300	57	50		1880	374	2396	6760	1120	1950	4
08	5	A	7.7/7	N	526693	436975	162890	124250	57	50		1685	262	1677	7860	1120	1950	4
08	7	A	7.7/7	N	598923	497970	158200	121100	57	50		1877	350	2236	7860	1120	1950	4
08	9	A	7.7/7	N	658659	537714	155050	119350	57	50		2067	437	2795	7860	1120	1950	4
08	5	A	8.8/8	N	601935	498897	186160	142000	58	51		1999	300	1917	8960	1120	1950	4
08	7	A	8.8/8	N	684483	568536	180800	138400	58	51		2216	400	2556	8960	1120	1950	4
08	9	A	8.8/8	N	752753	613912	177200	136400	58	51		2434	499	3194	8960	1120	1950	4

Model					Capacity		Air volume		Noise pressure level		Fan data			Dimensions				
Fan diameter	rows specification	fin pitch specification	heat exchanger spec. quantity of fan(s)	fan specification	condensing temperature temperature: 40 °C Delta T: 15 K refrigerant: R404a		Density 1.2 kg/m ³		Distance: 10 m Norm: EN 13487		empty weight	tube volume	exchange surface	length L	width B	height H	No. of feet	
					Delta in W	Star in W	Delta in m ³ /h	Star in m ³ /h	Delta in dB(A)	Star in dB(A)								in kg
08	5	A	2.2/2	L	128128	110880	36200	29200	45	39	n = 680 rpm / 530 rpm I = 2.4 A / 1.5 A P = 1050 W / 770 W Delta/star	537	75	479	2360	1120	1950	2
08	7	A	2.2/2	L	145712	123872	35300	28400	45	39		592	100	639	2360	1120	1950	2
08	9	A	2.2/2	L	155792	132160	34400	27600	45	39		648	125	799	2360	1120	1950	2
08	5	A	3.3/3	L	191423	165821	54300	43800	47	41		725	112	719	3460	1120	1950	2
08	7	A	3.3/3	L	217694	185251	52950	42600	47	41		807	150	958	3460	1120	1950	2
08	9	A	3.3/3	L	232753	197645	51600	41400	47	41		889	187	1198	3460	1120	1950	2
08	5	A	4.4/4	L	255231	220873	72400	58400	48	42		1033	150	958	4560	1120	1950	3
08	7	A	4.4/4	L	290258	246753	70600	56800	48	42		1140	200	1278	4560	1120	1950	3
08	9	A	4.4/4	L	310338	263263	68800	55200	48	42		1252	250	1597	4560	1120	1950	3
08	5	A	5.5/5	L	319039	275814	90500	73000	49	43		1177	187	1198	5660	1120	1950	3
08	7	A	5.5/5	L	362823	308132	88250	71000	49	43		1451	250	1597	5660	1120	1950	3
08	9	A	5.5/5	L	387922	328748	86000	69000	49	43		1587	312	1997	5660	1120	1950	3
08	5	A	6.6/6	L	383615	330644	108600	87600	50	44		1553	225	1438	6760	1120	1950	4
08	7	A	6.6/6	L	435387	369386	105900	85200	50	44		1718	300	1917	6760	1120	1950	4
08	9	A	6.6/6	L	465506	394101	103200	82800	50	44		1880	374	2396	6760	1120	1950	4
08	5	A	7.7/7	L	446654	385752	126700	102200	50	44		1685	262	1677	7860	1120	1950	4
08	7	A	7.7/7	L	507952	430951	123550	99400	50	44		1877	350	2236	7860	1120	1950	4
08	9	A	7.7/7	L	543091	459785	120400	96600	50	44		2067	437	2795	7860	1120	1950	4
08	5	A	8.8/8	L	510462	440415	144800	116800	51	45		1999	300	1917	8960	1120	1950	4
08	7	A	8.8/8	L	580517	492020	141200	113600	51	45		2216	400	2556	8960	1120	1950	4
08	9	A	8.8/8	L	620675	524940	137600	110400	51	45		2434	499	3194	8960	1120	1950	4



Model					Capacity		Air volume		Noise pressure level		Fan data			Dimensions				
Fan diameter	rows specification	fin pitch specification	heat exchanger spec. quantity of fan(s)	fan specification	condensing temperature		Density 1.2 kg/m ³		Distance: 10 m		empty weight	tube volume	exchange surface	length L	width B	height H	No. of feet	
					temperature: 40 °C	Delta T: 15 K	refrigerant: R404a	Delta in m ³ /h	Star in m ³ /h	Delta in dB(A)								Star in dB(A)
08	5	A	2.2/2	S	92624	76720	22400	17200	38	31	n = 440 rpm / 330 rpm P = 370 W / 200 W I = 1.2 A / 0.5 A	537	75	479	2360	1120	1950	2
08	7	A	2.2/2	S	101360	78288	21400	16400	38	31		592	100	639	2360	1120	1950	2
08	9	A	2.2/2	S	104384	81872	20600	15900	38	31		648	125	799	2360	1120	1950	2
08	5	A	3.3/3	S	138380	114735	33600	25800	40	33		725	112	719	3460	1120	1950	2
08	7	A	3.3/3	S	151432	117080	32100	24600	40	33		807	150	958	3460	1120	1950	2
08	9	A	3.3/3	S	155950	122440	30900	23850	40	33		889	187	1198	3460	1120	1950	2
08	5	A	4.4/4	S	184507	152826	44800	34400	41	34		1033	150	958	4560	1120	1950	3
08	7	A	4.4/4	S	201909	155950	42800	32800	41	34		1140	200	1278	4560	1120	1950	3
08	9	A	4.4/4	S	207933	163089	41200	31800	41	34		1252	250	1597	4560	1120	1950	3
08	5	A	5.5/5	S	230634	190841	56000	43000	42	35		1177	187	1198	5660	1120	1950	3
08	7	A	5.5/5	S	252386	194741	53500	41000	42	35		1451	250	1597	5660	1120	1950	3
08	9	A	5.5/5	S	259916	203657	51500	39750	42	35		1587	312	1997	5660	1120	1950	3
08	5	A	6.6/6	S	277316	228779	67200	51600	43	36		1553	225	1438	6760	1120	1950	4
08	7	A	6.6/6	S	302864	233455	64200	49200	43	36		1718	300	1917	6760	1120	1950	4
08	9	A	6.6/6	S	311899	244142	41800	47700	43	36		1880	374	2396	6760	1120	1950	4
08	5	A	7.7/7	S	322887	266909	78400	60200	43	36		1685	262	1677	7860	1120	1950	4
08	7	A	7.7/7	S	353341	272364	74900	57400	43	36		1877	350	2236	7860	1120	1950	4
08	9	A	7.7/7	S	363883	284833	72100	55650	43	36		2067	437	2795	7860	1120	1950	4
08	5	A	8.8/8	S	369014	304732	89600	68800	44	37		1999	300	1917	8960	1120	1950	4
08	7	A	8.8/8	S	403818	310960	85600	65600	44	37		2216	400	2556	8960	1120	1950	4
08	9	A	8.8/8	S	415866	325196	82400	63600	44	37		2434	499	3194	8960	1120	1950	4

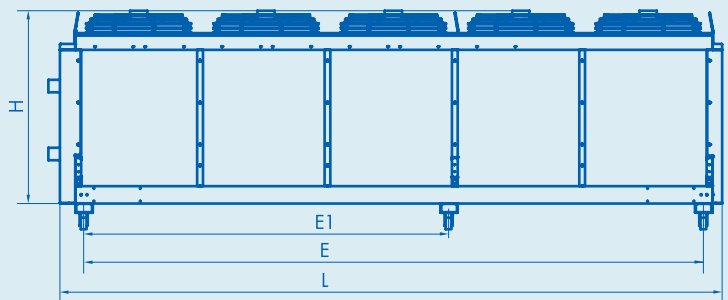
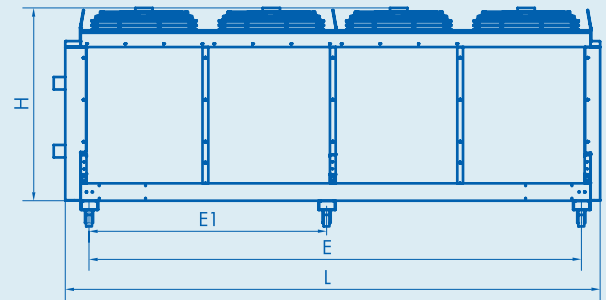
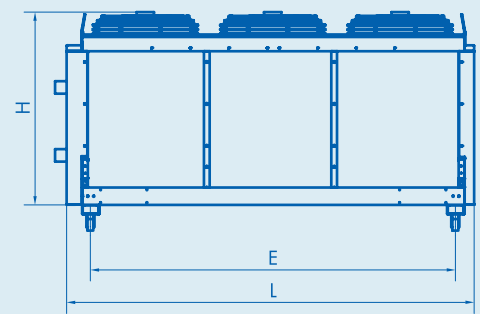
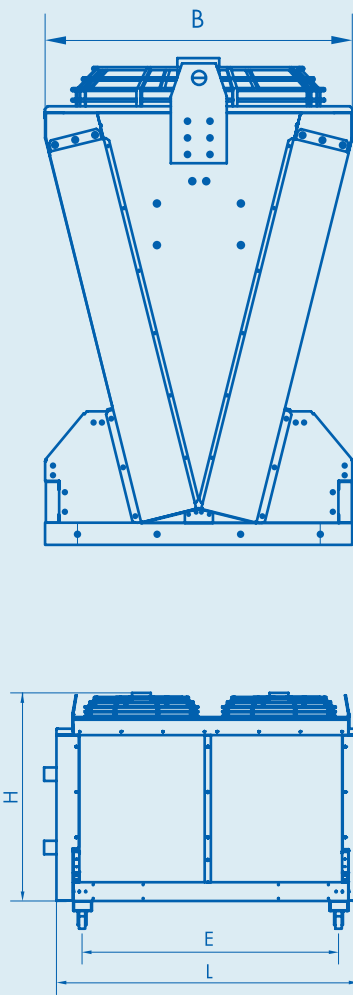

SPECIAL DESIGN

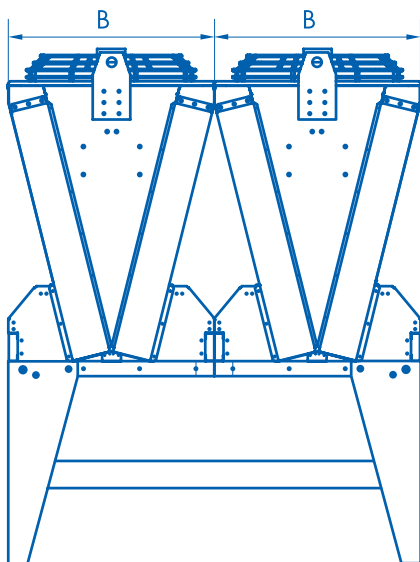

In order to ensure a constant and proper air supply, it is necessary to mount the units on a substructure when applying a double row or multiple row line-up. The frame construction system (substructure) that is also supplied ex-works (as an accessory) permits mounting at a height of up to two metres when two units are placed alongside each other (VV-shaped construction). This saves you a large part of the cost of having an expensive frame construction built as well as having to obtain building permission and undertake time-consuming construction work, all of which are currently necessary for our competitors.

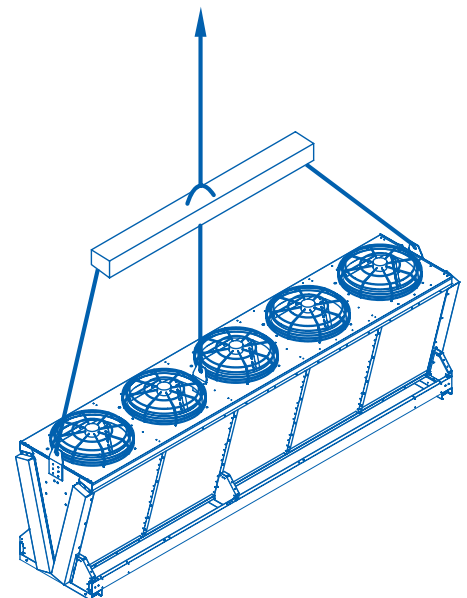

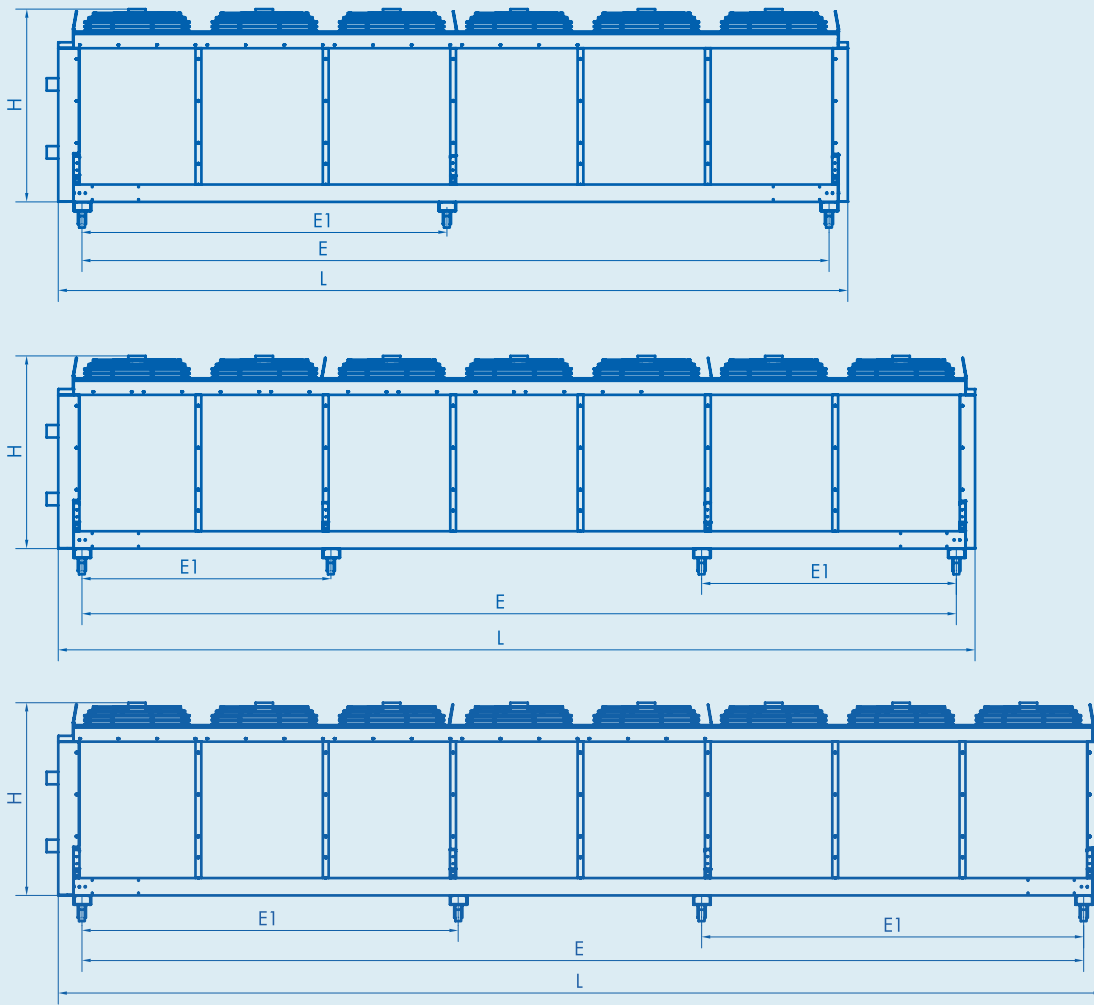

ADIABATIC SYSTEM



The advantages that adiabatic systems have over conventional closed-circuit evaporative cooling towers are manifold. Besides them being more economical, the spray water can be treated more easily (in the secondary circuit) and they have a longer service life. Protection against Legionella bacteria and the fact that it's unnecessary to dose the circuit water are only two of the further advantages these systems offer.

The result of CABERO's ongoing development activities is the new AS PRO (Adiabatic System PRO). What's special about this system is its high degree of efficiency while in operation. A vital aspect of the development was the CABERO process measuring and control unit, which plays a major role in reducing operating costs and improving safety in the plant.

Analyse your own plant to see if it makes sense to deploy these systems and get in touch with one of our technical offices for advice.



CABERO Version 08 / 2007

CABERO

HEAT EXCHANGER

CABERO Wärmetauscher GmbH & Co. KG
Jesenwanger Strasse 50
82284 Grafrath, Germany
Phone: +49 8144 9396-0
Fax: +49 8144 9396-20
E-mail: info@cabero.de | www.cabero.de

