

**ELEPHANT GV**

***instructions  
for  
installation***

*Document number: QSM000095E*

*Revision: A*

*Date of first issue: 21.Jan.04*

*Date of latest issue: 20.July.04*

**COSTAN<sup>®</sup>**

**F3000**

|  |                         |          |      |      |                                      |                                     |
|--|-------------------------|----------|------|------|--------------------------------------|-------------------------------------|
| <b>COSTAN</b> TECHNICAL DOCUMENTATION                    | CHAPTER REVISION STATUS |          |      |      | IN CONFORMITY WITH APPROVED ORIGINAL | PAGE: <b>1/1</b>                    |
|  | ORD.                    | DATE     | ORD. | DATE |                                      | DATE of 1st ISSUE: <b>21.Jan.04</b> |
|  | A                       | 20.07.04 | D    |      |                                      | ISSUED BY<br><b>MKT</b>             |
|  | B                       |          | E    |      |                                      |                                     |
| PRODUCT: ELEPHANT GV<br>CHAP. No. 1<br>CHAPTER: CONTENTS | DOC. no. QSM000095E     | C        |      | F    |                                      |                                     |

| CHAP. NO. | CHAPTER                               | NUMBER OF PAGES | REVISION STATUS |
|-----------|---------------------------------------|-----------------|-----------------|
| 1         | CONTENTS                              | 1               | A               |
| 2         | SECTIONS                              | 1               | "_"             |
| 3         | INSTALLATION DIAGRAMS                 | 3               | "_"             |
| 4         | POSITION OF PROBES                    | 1               | "_"             |
| 5         | HEAT EXTRACTION RATE DETAILS          | 2               | A               |
| 6         | ELECTRICAL DETAILS                    | 1               | "_"             |
| 7         | THERMOSTATIC VALVE FEATURES           | 2               | A               |
| 8         | CONTROLLER ADJUSTMENT - EKC201-EKC414 | 3               | "_"             |
| 8.1       | HOT GAS DEFROST                       | 1               | "_"             |
| 9         | WIRING DIAGRAMS                       | 14              | A               |
| 10        | MULTIPLEXING CABINETS                 | 6               | "_"             |
| 11        | PLACEMENT OF DRAINS                   | 2               | "_"             |
| 12        | REVERSING THE DOOR-OPENING SWING SIDE | 1               | "_"             |
| 13        | REVERSING FRAME BOTTOM PLATES         | 1               | "_"             |

**KEY**

"\_" First issue  
A, B, C..... Chapter revision index

| ORD. | DATE | ORD. | DATE |
|------|------|------|------|
| A    |      | D    |      |
| B    |      | E    |      |
| C    |      | F    |      |

**SECTIONS - ELEPHANT GV**

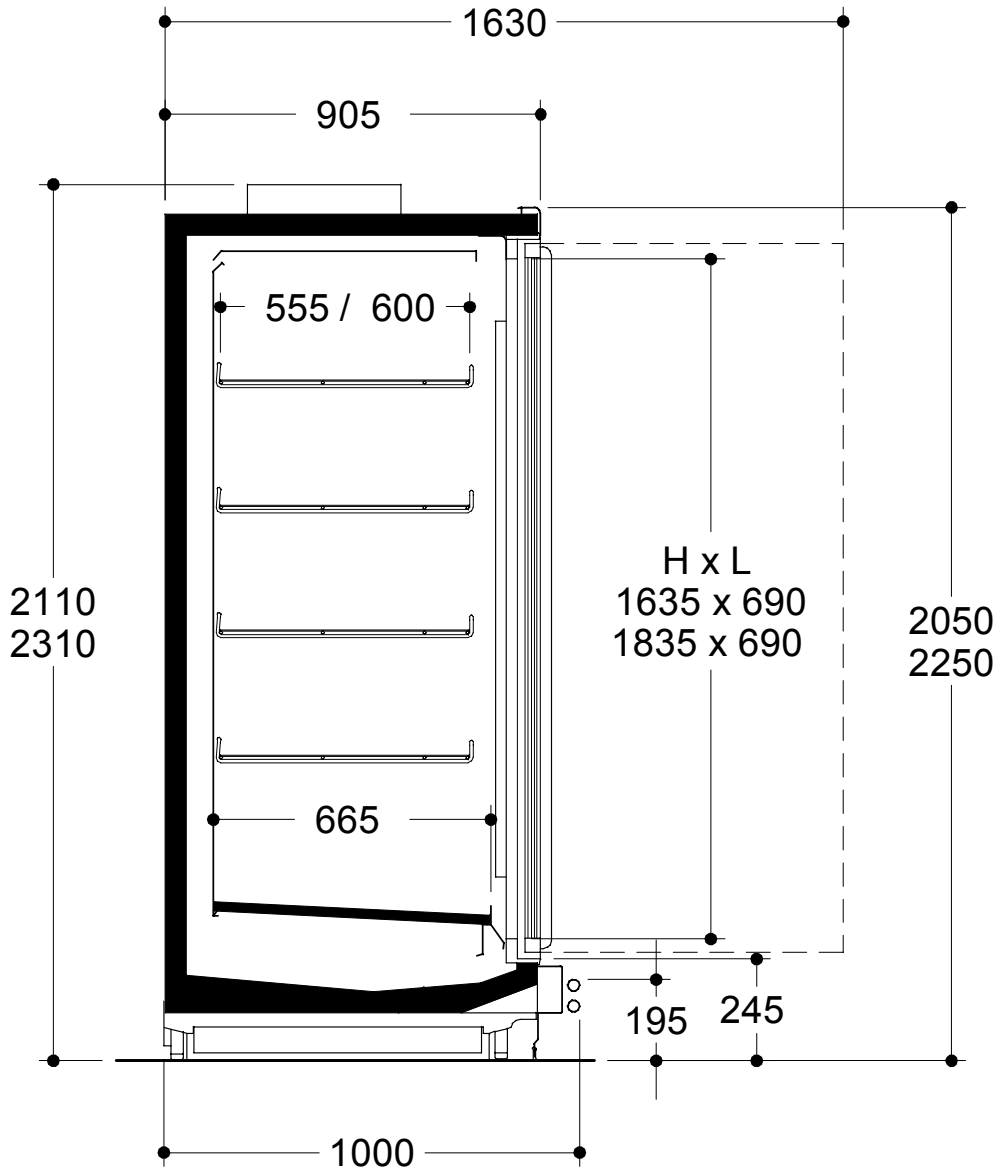

|  |                         |      |      |      |                                      |  |
|--|-------------------------|------|------|------|--------------------------------------|--|
| <b>COSTAN</b> TECHNICAL DOCUMENTATION  | CHAPTER REVISION STATUS |      |      |      | IN CONFORMITY WITH APPROVED ORIGINAL | PAGE: <b>1/3</b>                       |
|  | ORD.                    | DATE | ORD. | DATE |                                      | DATE of 1st ISSUE:<br><b>21.Jan.04</b> |
| PRODUCT: ELEPHANT GV<br>CHAP. No. 3      DOC. no. QSM000095E<br>CHAPTER: INSTALLATION DIAGRAMS | A                       |      | D    |      | ISSUED BY<br><b>MKT</b>              |  |
|  | B                       |      | E    |      |                                      |  |
|  | C                       |      | F    |      |                                      |  |

## INSTALLATION DIAGRAMS

### SECTION OF WATER AND REFRIGERATING CONNECTIONS

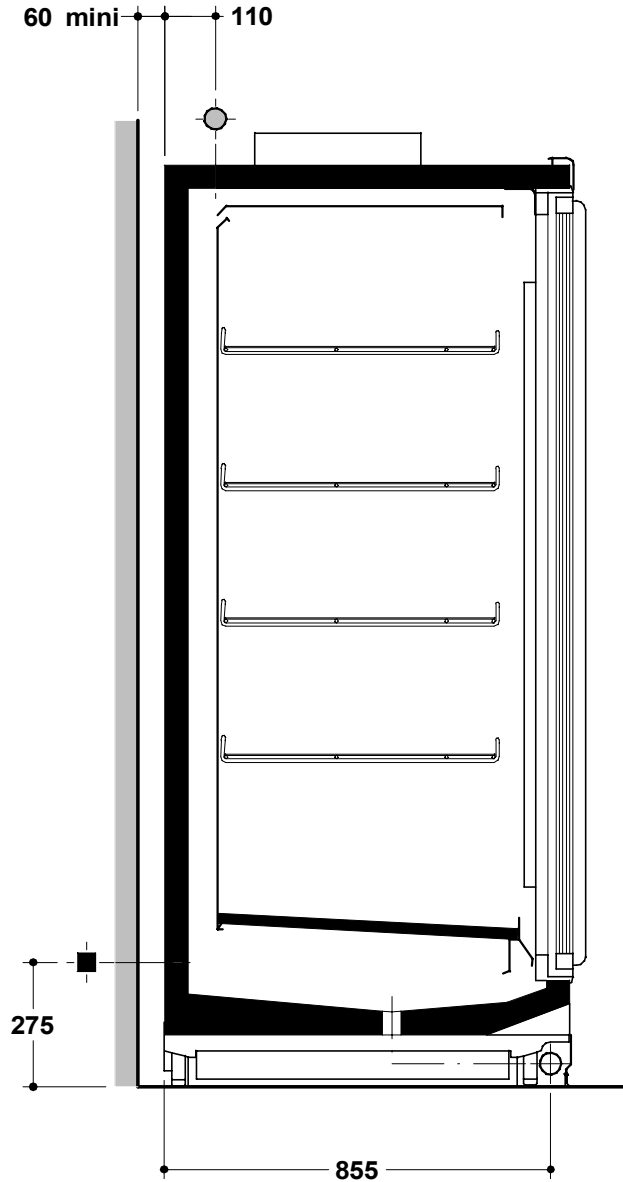

⊕ WATER OUTLET

● FREON OUTLET

| ORD. | DATE | ORD. | DATE |
|------|------|------|------|
| A    |      | D    |      |
| B    |      | E    |      |
| C    |      | F    |      |

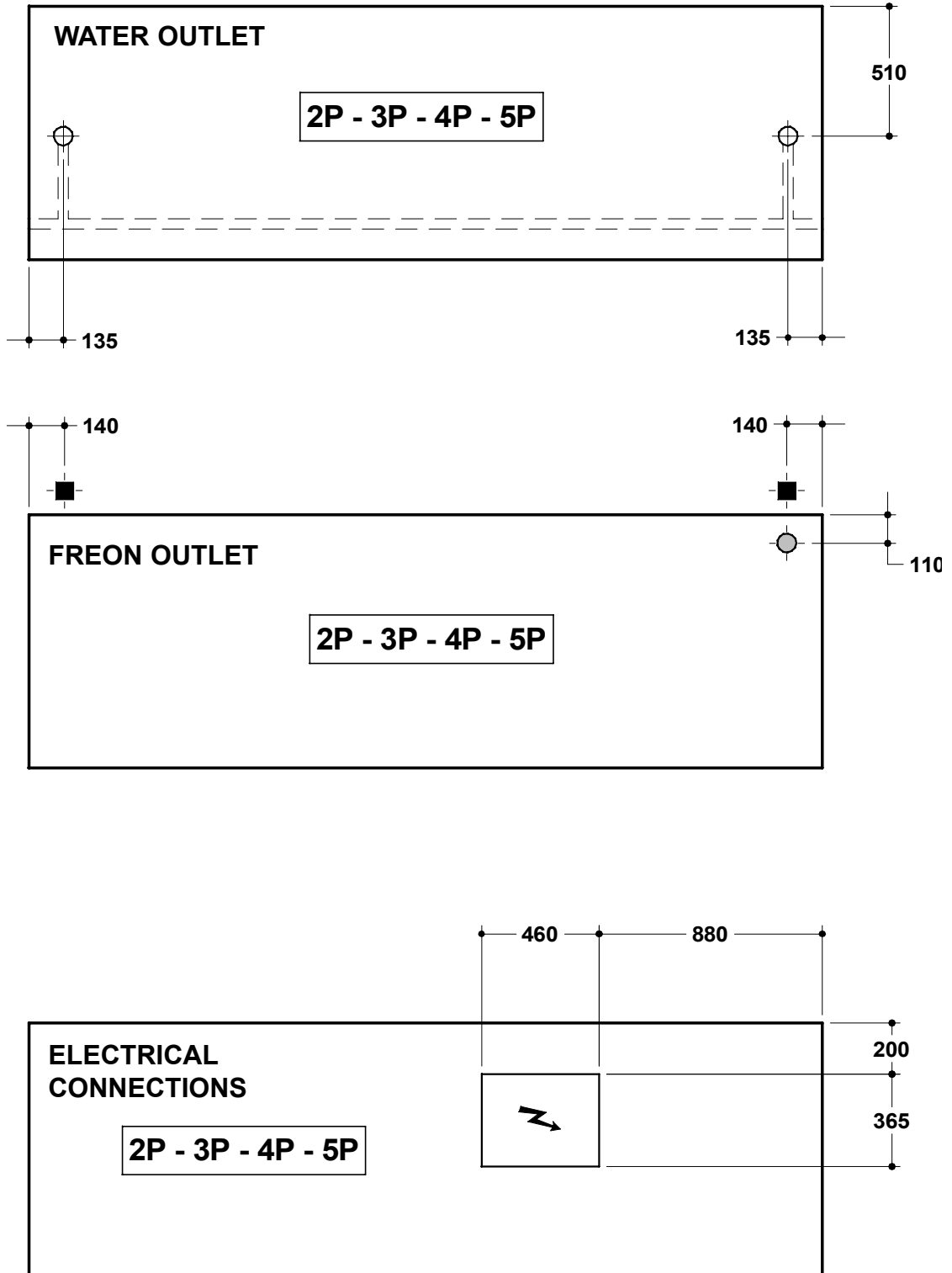

|                                       |                         |      |      |      |                                      |  |
|---------------------------------------|-------------------------|------|------|------|--------------------------------------|--|
| <b>COSTAN</b> TECHNICAL DOCUMENTATION | CHAPTER REVISION STATUS |      |      |      | IN CONFORMITY WITH APPROVED ORIGINAL | PAGE: <b>3/3</b>                       |
|                                       | ORD.                    | DATE | ORD. | DATE |                                      | DATE of 1st ISSUE:<br><b>21.Jan.04</b> |
| PRODUCT: ELEPHANT GV                  | A                       |      | D    |      | ISSUED BY<br><b>MKT</b>              |  |
| CHAP. No. 3      DOC. no. QSM000095E  | B                       |      | E    |      |                                      |  |
| CHAPTER: INSTALLATION DIAGRAMS        | C                       |      | F    |      |                                      |  |

### POSITION OF FEET

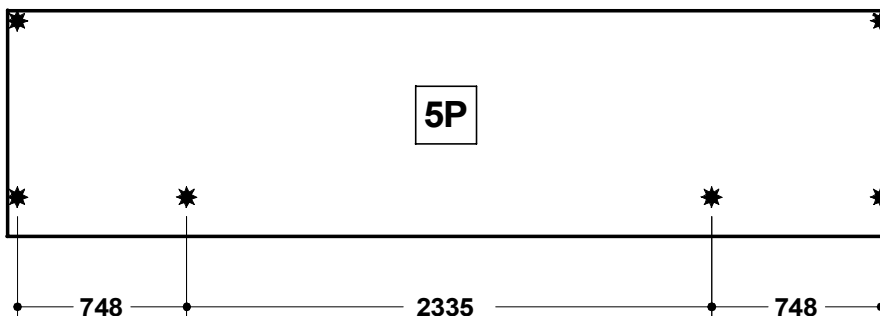
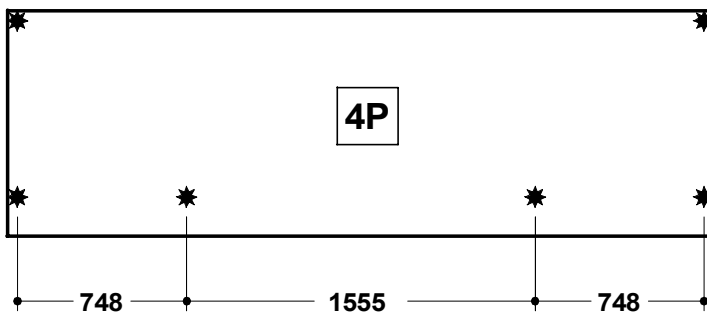
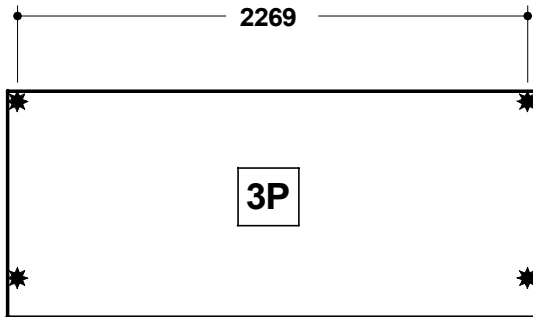
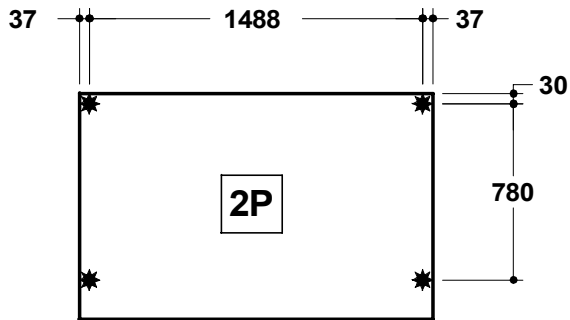

| ORD. | DATE | ORD. | DATE |
|------|------|------|------|
| A    |      | D    |      |
| B    |      | E    |      |
| C    |      | F    |      |

## POSITION OF PROBES - CONTROLLER - THERMOSTATIC VALVE

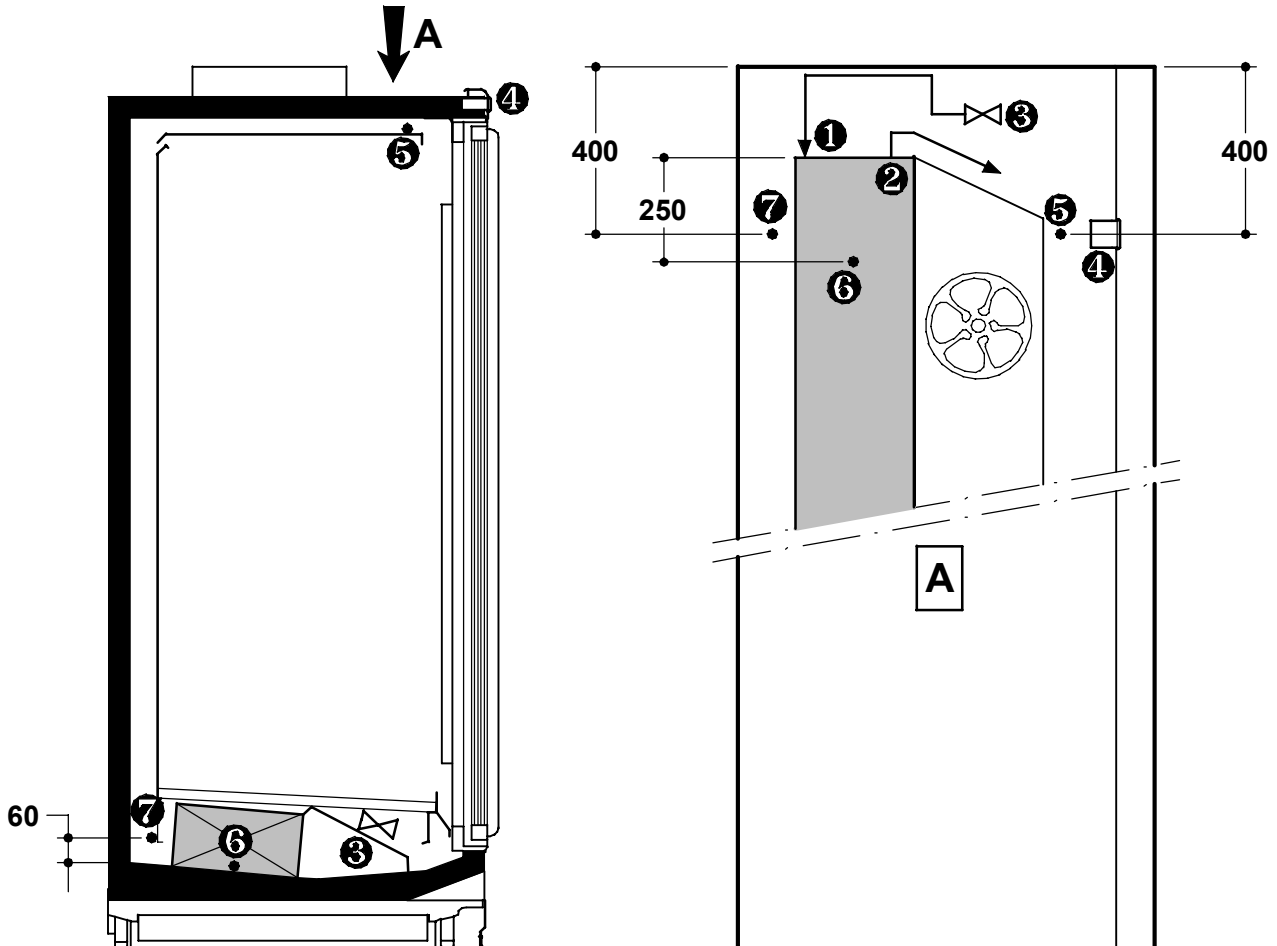

- ❶ Evaporator in-going piping
- ❷ Evaporator out-going piping
- ❸ Thermostatic valve
- ❹ Controller
- ❺ Position of air-outlet probes
- ❻ Position of defrost-end probes
- ❼ Safety thermostat

|  |                         |          |      |      |                                      |                    |
|--|-------------------------|----------|------|------|--------------------------------------|--------------------|
| <b>COSTAN</b> TECHNICAL DOCUMENTATION  | CHAPTER REVISION STATUS |          |      |      | IN CONFORMITY WITH APPROVED ORIGINAL | PAGE: <b>1/2</b>   |
|  | ORD.                    | DATE     | ORD. | DATE |                                      | DATE of 1st ISSUE: |
|  | A                       | 20.07.04 | D    |      |                                      | <b>21.Jan.04</b>   |
|  | B                       |          | E    |      |                                      | ISSUED BY          |
| PRODUCT: ELEPHANT GV<br>CHAP. No. 5 DOC. no. QSM000095E<br>CHAPTER: HEAT EXTRACTION RATE | C                       |          | F    |      | MKT                                  |                    |

## REQUIRED HEAT EXTRACTION RATE - SETTINGS

prEN 441-1 prEN 441-2 : 2001HR  
 EN 441-4 : 1994 EN 441-12 : 1997  
 CLA 3 : 25°C - 60% HR

| ELEPHANT GV | C   | IF   | T <sub>o</sub> °C | Φ <sub>o</sub> (W) |  |      |      |      |      |
|-------------|-----|------|-------------------|--------------------|--|------|------|------|------|
|             |     |      |                   | W/m                |  | 2P   | 3P   | 4P   | 5P   |
| H 2200      | 3L1 | HNLS | -34               | 810                |  | 1265 | 1900 | 2535 | 3165 |
| H 2000      | 3L1 | HNLS | -34               | 735                |  | 1150 | 1725 | 2300 | 2875 |
| H 2200      | 3M1 | HNLS | -10               | 440                |  | 690  | 1030 | 1375 | 1720 |
| H 2000      | 3M1 | HNLS | -10               | 400                |  | 625  | 940  | 1250 | 1565 |

| S.L.C.                      |     |      |       |       |            |        |                       |                    |                        |                         |
|-----------------------------|-----|------|-------|-------|------------|--------|-----------------------|--------------------|------------------------|-------------------------|
| M                           | C   | IF   | Ctrl  |       | Def        |        |                       |                    |                        |                         |
|                             |     |      | Ci °C | Co °C | Type       | N/24 h | T <sup>o</sup> ter °C | t <sub>d</sub> min | t <sub>egout</sub> min | t <sub>ventil</sub> min |
| AMPLEO / R<br>H2050 / H2250 | 3L1 | HNLS | -27   | -28   | Electrique | 1      | 15                    | 30                 | 10                     | 5                       |
|                             |     |      |       |       | Gaz chaud  | 1      | 10                    | 10                 | 5                      | 5                       |
| AMPLEO / R<br>H2050 / H2250 | 3M1 | HNLS | -3    | -4    | Electrique | 1      | 10                    | 10                 | 5                      | 0                       |

t<sub>d</sub> : defrost duration

t<sub>egout</sub> : drip-off duration

t<sub>vent</sub> : fan start delay

|   |                         |                 |      |      |                                      |  |
|---|-------------------------|-----------------|------|------|--------------------------------------|--|
| <b>COSTAN</b> TECHNICAL DOCUMENTATION   | CHAPTER REVISION STATUS |                 |      |      | IN CONFORMITY WITH APPROVED ORIGINAL | PAGE: <b>2/2</b>                       |
|   | ORD.                    | DATE            | ORD. | DATE |                                      | DATE of 1st ISSUE:<br><b>21.Jan.04</b> |
|   | A                       | <b>20.07.04</b> | D    |      |                                      | ISSUED BY<br><b>MKT</b>                |
|   | B                       |                 | E    |      |                                      |  |
| C   |                         | F               |      |      |                                      |  |
| PRODUCT: ELEPHANT GV<br>CHAP. No. <b>5</b> N° DOC. <b>QSM000095E</b><br>CHAPTER: HEAT EXTRACTION RATE |                         |                 |      |      |                                      |  |

## SAFETY TIME FOR DEFROST

|                         | Safety time in min |
|-------------------------|--------------------|
| <b>Electric defrost</b> | <b>45</b>          |
| <b>Hot gas defrost</b>  | <b>15</b>          |

| <b>CHECKING</b>           |            |            |  |
|---------------------------|------------|------------|--|
| Alarm out of defrost time |            |            |  |
| <b>C</b>                  | Threshold  | Delay time | Minimum time after defrost termination |
|                           | °C         | min        | min                                    |
| <b>3L1</b>                | <b>-15</b> | <b>10</b>  | <b>35</b>                              |
| <b>3M1</b>                | <b>4</b>   | <b>10</b>  | <b>35</b>                              |



|  |                         |      |      |      |                                      |  |
|--|-------------------------|------|------|------|--------------------------------------|--|
| <b>COSTAN</b> TECHNICAL DOCUMENTATION  | CHAPTER REVISION STATUS |      |      |      | IN CONFORMITY WITH APPROVED ORIGINAL | PAGE: <b>1/2</b>                       |
|  | ORD.                    | DATE | ORD. | DATE |                                      | DATE of 1st ISSUE:<br><b>21.Jan.04</b> |
|  | A                       |      | D    |      |                                      | ISSUED BY<br><b>MKT</b>                |
|  | B                       |      | E    |      |                                      |  |
| PRODUCT: ELEPHANT GV<br>CHAP. No. 7 N° DOC. QSM000095E<br>CHAPTER: THERMAL-EXPANSION VALVE | C                       |      | F    |      |                                      |  |

## FEATURES OF DANFOSS THERMOSTATIC VALVE

### FEATURES OF DANFOSS THERMOSTATIC VALVE WITHOUT MOP - FITTING TO BE SOLDERED

Selection rules:

- effective heat extraction rate and evaporating temperature at lab conditions (25 °C 60% R.H. class 3);
- condensing pressure equivalent to a temperature of +35°C;
- undercooling 10 K.

|                        |             | <b>R404A</b>           |               |                        |               |
|------------------------|-------------|------------------------|---------------|------------------------|---------------|
|                        |             | <b>3L1 / Range - B</b> |               | <b>3M1 / Range - N</b> |               |
| <b>ELEPHANT<br/>GV</b> | <b>L</b>    | <i>TYPE</i>            | <i>NOZZLE</i> | <i>TYPE</i>            | <i>NOZZLE</i> |
|                        |             | <b>H 2000</b>          | <b>2P</b>     | <b>TS2</b>             | <b>02</b>     |
| <b>3P</b>              | <b>03</b>   |                        | <b>01</b>     |                        |               |
| <b>4P</b>              | <b>03</b>   |                        | <b>01</b>     |                        |               |
| <b>5P</b>              | <b>TES2</b> |                        | <b>04</b>     | <b>TES2</b>            | <b>01</b>     |
| <b>H 2200</b>          | <b>2P</b>   | <b>TS2</b>             | <b>02</b>     | <b>TS2</b>             | <b>00</b>     |
|                        | <b>3P</b>   |                        | <b>03</b>     |                        | <b>01</b>     |
|                        | <b>4P</b>   |                        | <b>04</b>     |                        | <b>01</b>     |
|                        | <b>5P</b>   | <b>TES2</b>            | <b>04</b>     | <b>TES2</b>            | <b>02</b>     |

Refrigerating details refer to cabinets with thermostatic valves set to provide an undercooling value of 5K.

|  |                         |      |      |      |                                      |  |
|--|-------------------------|------|------|------|--------------------------------------|--|
| <b>COSTAN</b> TECHNICAL DOCUMENTATION  | CHAPTER REVISION STATUS |      |      |      | IN CONFORMITY WITH APPROVED ORIGINAL | PAGE: <b>2/2</b>                       |
|  | ORD.                    | DATE | ORD. | DATE |                                      | DATE of 1st ISSUE:<br><b>21.Jan.04</b> |
|  | A                       |      | D    |      |                                      | ISSUED BY<br><b>MKT</b>                |
|  | B                       |      | E    |      |                                      |  |
| PRODUCT: ELEPHANT GV<br>CHAP. No. 7      DOC. no. QSM000095E<br>CHAPTER: THERMAL-EXPANSION VALVE | C                       |      | F    |      |                                      |  |

## FEATURES OF DANFOSS THERMOSTATIC VALVE

Selection rules:

- effective heat extraction rate and evaporating temperature at lab conditions (25 °C 60% R.H. class 3);
- condensing pressure equivalent to a temperature of +35°C;
- undercooling 10 K.
- considering overcapacity as 25% and valve opening between 50 and 75%.

|               |     |               | <b>R404A</b>  |               |
|---------------|-----|---------------|---------------|---------------|
|               |     |               | 3L1           | 3M1           |
| ELEPHANT GV   | L   | Type          | <i>Nozzle</i> | <i>Nozzle</i> |
| <b>H 2200</b> | 2 P | <b>AKV 10</b> | 3             | 1             |
|               | 3 P |               | 4             | 2             |
|               | 4 P |               | 5             | 3             |
|               | 5 P |               | 5             | 3             |
| <b>H 2000</b> | 2 P |               | 3             | 1             |
|               | 3 P |               | 4             | 2             |
|               | 4 P |               | 4             | 3             |
|               | 5 P |               | 5             | 3             |

Refrigerating details refer to cabinets with thermostatic valves set to provide an undercooling value of 5K.

### Ø DISCHARGE PIPING - SUCTION PIPING: 7

| <b>REFRIGERANT</b>     |                            |    |    |    |                   |  |                              |  |
|------------------------|----------------------------|----|----|----|-------------------|--|------------------------------|--|
| ELEPHANT GV            | Ø (mm) <i>SUCTION SIDE</i> |    |    |    |                   |  | Ø (mm) <i>DISCHARGE SIDE</i> |  |
|                        | 2P                         | 3P | 4P | 5P | 2P - 3P - 4P - 5P |  |                              |  |
| <b>H2000<br/>H2200</b> | 15                         | 18 | 18 | 22 | 10                |  |                              |  |

| <b>GLYCOL COOLANT</b>  |                   |
|------------------------|-------------------|
| ELEPHANT GV            | Ø (mm)            |
|                        | 2P - 3P - 4P - 5P |
| <b>H2000<br/>H2200</b> | 28                |

## SETTINGS FOR CONTROLLER EKC201

| Parameter function  | Parameters for Danfoss Controller | Min. value for Danfoss Controller | Max. value for Danfoss Controller |
|---|-----------------------------------|-----------------------------------|-----------------------------------|
| <b>Thermostat parameters</b>  |                                   |                                   |                                   |
| 1. Cutout T° for S4 / Sout *  | OUT                               | -50°C                             | 50°C                              |
| 2. Temperature unit (°C/°F)   | r05                               | °C                                | °F                                |
| 3. S4 / Sout differential (r07 = Sout cut-in T° * - cut-out T°)           | r07                               | 0.1 K                             | 20 K                              |
| 4. S3 / Sin differential (r08 = cut-in T° * - cut-out T° Sin)             | r08                               | 0.1 K                             | 20 K                              |
| 5. Correction of signal from S4/Sout                                      | r09                               | -20.0 K                           | 20.0 K                            |
| 6. Correction of signal from S3/Sin                                       | r10                               | -20.0 K                           | 20.0 K                            |
| 7. Sin – Sout differential  | r20                               | 0 K                               | 10 K                              |
| <b>Alarm parameters</b>   |                                   |                                   |                                   |
| 1. Timing of temperature alarm *  | A03                               | 0 min                             | 90 min                            |
| 2. Timing of door alarm   | A04                               | 0 min                             | 90 min                            |
| 3. Upper limit exceeded S4/Sout (A05 =threshold * - cut-out T° of Sout)   | A05                               | 0 K                               | 50 K                              |
| 4. Lower limit of S4/Sout exceeded  | A06                               | -50 K                             | 0 K                               |
| 5. Upper limit of S3/Sout exceeded (A07 =threshold * - cut-out T° of Sin) | A07                               | 0 K                               | 50 K                              |
| 6. Lower limit of S3/Sin exceeded   | A08                               | -50 K                             | 0 K                               |
| 7. S3/Sin alarm time-lag with night covers                                | A09                               | -50 K                             | 50 K                              |
| <b>VEM Parameters</b>   |                                   |                                   |                                   |
| 1. Min. ON-time   | c01                               | 0 min                             | 15 min                            |
| 2. Gap between two defrosts   | c02                               | 0 min                             | 15 min                            |
| 3. Cut-in frequency in case of probe fault                                | c03                               | 0%                                | 100%                              |
| 4. Compressor cut-out on door opening (yes/no)                            | c04                               | No                                | Yes                               |
| <b>Defrost parameters</b>   |                                   |                                   |                                   |
| 1. Compressor On when under defrosting                                    | d01                               | No                                | Yes                               |
| 2. Defrost-end T° * (probe selection automatic according to d10)          | d02                               | 0                                 | 25 °C                             |
| 3. Gap between 2 defrosts (d03=24 / n° of defrosts per day*)              | d03                               | OFF                               | 48 h                              |
| 4. Safety time *  | d04                               | 0 min                             | 180 min                           |
| 5. Defrost signal time-lag after start-up                                 | d05                               | 0 min                             | 60 min                            |
| 6. Drip off time  | d06                               | 0 min                             | 20 min                            |
| 7. Timing of fan start on defrost end                                     | d07                               | 0 min                             | 20 min                            |
| 8. Fan start temperature (>25C°=OFF)                                      | d08                               | -25                               | 26°C                              |
| 9. Fan operation when defrosting (yes/no)                                 | d09                               | No                                | Yes                               |
| 10. Defrost probe   | d10                               | OUT                               | DEF                               |
| 11. Alarm delay on defrost end *  | d11                               | 0 min                             | 200 min                           |
| 12. Delay of display view after defrost end                               | d12                               | 0 min                             | 30 min                            |
| 13. Defrost on start-up   | d13                               | No                                | Yes                               |
| <b>Real time clock parameters</b>   |                                   |                                   |                                   |
| 1. 1. Defrost start, hour   | t01                               | OFF                               | 23 h                              |
| 2. 1. Defrost start, minutes  | t11                               | 0 min                             | 59 min                            |
| 3. 2. Defrost start, hour   | t02                               | OFF                               | 23 h                              |
| 4. 2. Defrost start, minutes  | t12                               | 0 min                             | 59 min                            |
| 5. 3. Defrost start, hour   | t03                               | OFF                               | 23 h                              |
| 6. 3. Defrost start, minutes  | t13                               | 0 min                             | 59 min                            |
| 7. 4. Defrost start, hour   | t04                               | OFF                               | 23 h                              |
| 8. 4. Defrost start, minutes  | t14                               | 0 min                             | 59 min                            |
| 9. 5. Defrost start, hour   | t05                               | OFF                               | 23 h                              |
| 10. 5. Defrost start, minutes   | t15                               | 0 min                             | 59 min                            |
| 11. 6. Defrost start, hour  | t06                               | OFF                               | 23 h                              |
| 12. 6. Defrost start, minutes   | t16                               | 0 min                             | 59 min                            |
| 13. Adjustment of hour  | t07                               | 0 h                               | 23 h                              |
| 14. Adjustment of minutes   | t08                               | 0 min                             | 59 min                            |
| <b>Ventilation parameters</b>   |                                   |                                   |                                   |
| 1. Fans off when compressors are off                                      | F01                               | No                                | Yes                               |
| 2. Fan off time   | F02                               | 0 min                             | 15 min                            |
| 3. Fans off on door opening   | F03                               | No                                | Yes                               |
| <b>Other parameters</b>   |                                   |                                   |                                   |
| 1. Output delay on startup  | o01                               | 0 sec                             | 600 sec                           |
| 2. Digital input signals  | o02                               | OFF                               | 5                                 |
| 3. Network address (from 0 to 60)   | o03                               | 0                                 | 990                               |
| 4. LON service connector  | o04                               | OFF                               | ON                                |
| 5. Access code  | o05                               | OFF                               | 100                               |
| 6. Type of probe used (Pt/PtC)  | o06                               | Pt                                | PTC                               |
| 7. Max. delay after defrost synchronised with branch cabinets             | o13                               | OFF                               | 2                                 |
| 8. Selection of regulation probe  | o14                               | Aut                               | OUT                               |
| 9. Temperature display scale  | o15                               | No                                | Yes                               |
| 10. Max wait time after synchronized defrost                              | o16                               | 1 min                             | 30 min                            |
| 11. Selection of display probe signal                                     | o17                               | Aut                               | In                                |
| 12. Manual output command   | o18                               | OFF                               | 5                                 |
| 13. Relay functions (alarm/lighting)                                      | o36                               | 1                                 | 2                                 |

| EC5 T°- ELEPHANT GV DANFOSS EKC201C  | EC5 T°+ ELEPHANT GV DANFOSS EKC201C |
|--|-------------------------------------|
| -28  | -4                                  |
| °C   | °C                                  |
| 1  | 1                                   |
| 1  | 1                                   |
| 0  | 0                                   |
| 0  | 0                                   |
| 0  | 0                                   |
| 10   | 10                                  |
| 60   | 60                                  |
| 13   | 9                                   |
| -50  | -50                                 |
| 50   | 50                                  |
| -50  | -50                                 |
| 0  | 0                                   |
| 0  | 0                                   |
| 0  | 0                                   |
| 100  | 100                                 |
| No   | No                                  |
| No   | No                                  |
| 15   | 10                                  |
| 24   | 24                                  |
| 45   | 20                                  |
| 0  | 0                                   |
| 10   | 5                                   |
| 5  | 0                                   |
| OFF  | OFF                                 |
| No   | No                                  |
| DEF  | DEF                                 |
| 35   | 35                                  |
| 0  | 0                                   |
| No   | No                                  |
| Values to be defined at the time of installation only for Danfoss Controllers model S or S/C |                                     |
| No   | No                                  |
| 0  | 0                                   |
| No   | No                                  |
| 0  | 0                                   |
| Values to be defined at the time of installation   |                                     |
| OFF  | OFF                                 |
| Pt / PTC   | Pt / PTC                            |
| Values to be defined at the time of installation only for Danfoss Controller Models S or S/C |                                     |
| OUT  | OUT                                 |
| Yes  | Yes                                 |
| 15   | 15                                  |
| OUT  | OUT                                 |
| OFF  | OFF                                 |
| 1  | 1                                   |

\* Parameters to be adapted to the climatic class required by the foods in question

## SETTINGS FOR CONTROLLER EKC414 - TAB.1

| SETTINGS FOR CONTROLLER EKC414 - TAB.1 |  |     |         |          | EC5<br>T°-<br>ELEPHANT<br>GV | EC5<br>T°+<br>ELEPHANT<br>GV |
|--|--|-----|---------|----------|------------------------------|------------------------------|
| Function                               | Parameter  | MIN | MAX     |          |                              |                              |
| <b>Thermostat</b>                      |  |     |         |          |                              |                              |
| <b>Set point •</b>                     |  |     |         |          | <b>-28</b>                   | <b>-4</b>                    |
| 1                                      | Differential   | r01 | 0.1K    | 10.0K    | 1                            | 1                            |
| 2                                      | Max. limitation of thermostat set-point                                      | r02 | -49°C   | 50°C     | -25                          | 0                            |
| 3                                      | Min. limitation of thermostat set-point                                      | r03 | -50°C   | 49°C     | -35                          | -10                          |
| 4                                      | Temperature unit   | r05 | °C      | °F       | °C                           | °C                           |
| 5                                      | Correction of the signal from S4 (Sout)                                      | r09 | -10.0K  | 10.0K    | 0                            | 0                            |
| 6                                      | Correction of the signal from S3 (Sin)                                       | r10 | -10.0K  | 10.0K    | 0                            | 0                            |
| 7                                      | Main switch for the controller   | r12 | OFF     | ON       | ON                           | ON                           |
| 8                                      | Night Offset   | r13 | -20.0K  | 20.0K    | 0                            | 0                            |
| 9                                      | Thermostat mode<br>1 = ON/OFF, 2 = Modulating                                | r14 | 1       | 2        | 1                            | 1                            |
| 10                                     | Weighting of sensors for thermostat<br>100%=S4 (Sout), 0%=S3 (Sin)           | r15 | 0%      | 100%     | 100                          | 100                          |
| 11                                     | Interval between defrost starts  | r16 | 0 h     | 10 h     | 0                            | 0                            |
| 12                                     | Defrost duration   | r17 | 0 min   | 10 min   | 0                            | 0                            |
| <b>Alarms</b>                          |  |     |         |          |                              |                              |
| 1                                      | Delay for temperature alarm  | A03 | 0 min   | 120 min  | 10                           | 10                           |
| 2                                      | Delay for door alarm   | A04 | 0 min   | 90 min   | 90                           | 90                           |
| 3                                      | Delay for pulldown   | A12 | 0 min   | 240 min  | 60                           | 60                           |
| 4                                      | High temperature limit •   | A13 | -50°C   | 50°C     | -15                          | 5                            |
| 5                                      | Low temperature limit  | A14 | -50°C   | 50°C     | -50                          | -50                          |
| <b>Compressor function</b>             |  |     |         |          |                              |                              |
| 1                                      | Min. ON-time   | c01 | 0 min.  | 50 min.  | 0                            | 0                            |
| 2                                      | Min. OFF-time  | c02 | 0 min.  | 50 min.  | 0                            | 0                            |
| <b>Defrost</b>                         |  |     |         |          |                              |                              |
| 1                                      | Defrost stop temperature   | d02 | 0       | 25°C     | 15                           | 10                           |
| 2                                      | Interval between defrost starts •  | d03 | OFF     | 48 h     | 24                           | 24                           |
| 3                                      | Max. defrost duration  | d04 | 0       | 180 min  | 45                           | 20                           |
| 4                                      | Defrost delay after power up   | d05 | 0       | 240 min  | 0                            | 0                            |
| 5                                      | Drip-off time  | d06 | 0       | 60 min   | 10                           | 5                            |
| 6                                      | Delay for fan start after defrost  | d07 | 0       | 60 min   | 5                            | 0                            |
| 7                                      | Fan start temperature  | d08 | -15     | 0°C      | 0                            | 0                            |
| 8                                      | Fans on during defrost (yes/no)  | d09 | No      | yes      | No                           | No                           |
| 9                                      | Defrost sensor<br>0=S4 (Sout), 1=S5 (Sdef), 2=none i.e. time-controlled stop | d10 | 0       | 2        | 1                            | 1                            |
| 10                                     | Defrost start on power up  | d13 | No      | yes      | No                           | No                           |
| <b>Realtime clock</b>                  |  |     |         |          |                              |                              |
| 1                                      | 1. Defrost start. Hours  | t01 | OFF     | 23hours  |                              |                              |
| 2                                      | 1. Defrost start. Minutes  | t11 | 0       | 59 min   |                              |                              |
| 3                                      | 2. Defrost start. Hours  | t02 | OFF     | 23hours  |                              |                              |
| 4                                      | 2. Defrost start. Minutes  | t12 | 0       | 59 min   |                              |                              |
| 5                                      | 3. Defrost start. Hours  | t03 | OFF     | 23hours  |                              |                              |
| 6                                      | 3. Defrost start. Minutes  | t13 | 0       | 59 min   |                              |                              |
| 7                                      | 4. Defrost start. Hours  | t04 | OFF     | 23hours  |                              |                              |
| 8                                      | 4. Defrost start. Minutes  | t14 | 0       | 59 min   |                              |                              |
| 9                                      | 5. Defrost start. Hours  | t05 | OFF     | 23hours  |                              |                              |
| 10                                     | 5. Defrost start. Minutes  | t15 | 0       | 59 min   |                              |                              |
| 11                                     | 6. Defrost start. Hours  | t06 | OFF     | 23hours  |                              |                              |
| 12                                     | 6. Defrost start. Minutes  | t16 | 0       | 59 min   |                              |                              |
| 13                                     | Setting of Hours   | t07 | 0       | 23hours  |                              |                              |
| 14                                     | Setting of minutes   | t08 | 0       | 59 min   |                              |                              |
| 15                                     | Start time of day operation (0=constant day)                                 | t17 | 0       | 23       |                              |                              |
| 16                                     | Start time night operation (0=constant day)                                  | t18 | 0       | 23       |                              |                              |
| <b>Injection control</b>               |  |     |         |          |                              |                              |
| 1                                      | Max. limit of superheat reference  | n09 | 3.0 K   | 15.0 K   | 6                            | 6                            |
| 2                                      | Min. limit of superheat reference  | n10 | 3.0 K   | 10.0 K   | 4                            | 4                            |
| 3                                      | MOP Temperature  | n11 | -50.0°C | 15°C/off | OFF                          | OFF                          |
| 5                                      | AKV pulsing period   | n13 | 3 sec.  | 6 sec.   | 6                            | 6                            |
| 10                                     | Stability  | n18 | 0       | 10       | 4                            | 4                            |
| 11                                     | Forced closing<br>ON =AkV closed   | n36 | OFF     | ON       | OFF                          | OFF                          |

Values for Controller Danfoss  
C or S/C to be defined at the  
time of installation

|                                       |                         |      |      |      |                                      |                                 |
|---------------------------------------|-------------------------|------|------|------|--------------------------------------|---------------------------------|
| <b>COSTAN</b> TECHNICAL DOCUMENTATION | CHAPTER REVISION STATUS |      |      |      | IN CONFORMITY WITH APPROVED ORIGINAL | PAGE: <b>3/3</b>                |
|                                       | ORD.                    | DATE | ORD. | DATE |                                      |                                 |
|                                       | A                       |      | D    |      |                                      |                                 |
|                                       | B                       |      | E    |      |                                      |                                 |
| PRODUCT: ELEPHANT GV                  |                         |      |      |      |                                      | DATE of 1st ISSUE:<br>21.Jan.04 |
| CHAP. No. 8                           | N° DOC. QSM000095E      |      |      |      |                                      | ISSUED BY<br>MKT                |
| CHAPTER: CONTROLLER ADJUSTMENT        |                         |      |      |      |                                      |                                 |

## SETTINGS FOR CONTROLLER EKC414 - TAB.2

| Function   |  | Parameter | MIN    | MAX      | EC5 T <sup>-</sup> ELEPHANT GV   | EC5 T <sup>+</sup> ELEPHANT GV |
|--|--|-----------|--------|----------|--|--------------------------------|
| <b>Fan control</b>   |  |           |        |          |  |                                |
| 1  | Fan stop on compressor cut out   | F01       | No     | yes      | No   | No                             |
| 2  | Fan stop delay when compressor cuts out  | F02       | 0 min  | 30 min   | 0  | 0                              |
| 3  | Temperature limit for fan stopped via S5 (Sdef) value  | F04       | -50.0  | 50.0/off | OFF  | OFF                            |
| <b>Miscellaneous</b>   |  |           |        |          |  |                                |
| 1  | Delay of output signal after start up  | o01       | 0 sec  | 600 sec  | 0  | 0                              |
| 2  | DI control<br>OFF=not used, 1=door alarm, 2=Defrost start, 3=Night, 4=Main switch, 5=Slave defrost                                 | o02       | OFF    | 5        | Values to be defined at the time of installation                                 |                                |
| 3  | Network address  | o03       | 0      | 990      |  |                                |
| 4  | ON/OFF Switch (service-pin message)  | o04       | OFF    | ON       |  |                                |
| 5  | Access code  | o05       | OFF    | 100      |  |                                |
| 6  | Used sensor type (Pt/PTC)  | o06       | Pt     | PTC      | Pt/PTC   | Pt/PTC                         |
| 7  | Language<br>0=English, 1=German, 2=French, 3=Danish, 4=Spanish, 5=Italian  | o11       | 0      | 5        | 0  | 0                              |
| 7  | Voltage selection 50/60 Hz   | o12       | 50     | 60       | 50   | 50                             |
| 8  | DO output controls<br>OFF=not used, 1=Def. Master, 2=Def. Slave  | o13       | 0      | 2        | Values for controller Danfoss C or S/C to be defined at the time of installation |                                |
| 10   | Display step<br>no=0.1, yes =0.5   | o15       | No     | yes      | yes  | yes                            |
| 11   | Max. standby on defrost end  | o16       | 1 min  | 30 min   | 15   | 30                             |
| 12   | Display S4 % (Sout)<br>0%=S3 (Sin)<br>100%=S4 (Sout)   | o17       | 0%     | 100%     | 100  | 100                            |
| 13   | Manual control of output via EKC   | o18       | OFF    | 7        | OFF  | OFF                            |
| 14   | Pressare min. value  | o20       | -1 bar | 5 bar    | -1   | -1                             |
| 15   | Pressure max. value  | o21       | 6 bar  | 36 bar   | 12   | 12                             |
| 16   | ON input control   | o29       | 1      | 4        | 1  | 1                              |
| 17   | Refrigerant selection<br>ONLY for the use of R404A .<br>WARNING: Wrong selection of refrigerant may cause damage to the compressor | o30       | 0      | 30       | 19   | 19                             |
| <b>Service</b>   |  |           |        |          |  |                                |
| 1  | u09 ... u26  |           |        |          | read only  | read only                      |
| <ul style="list-style-type: none"> <li>Parameter to be adapted to food temperature class or ambient conditions.</li> </ul> |  |           |        |          |  |                                |

## HOT GAS DEFROST DIAGRAMS

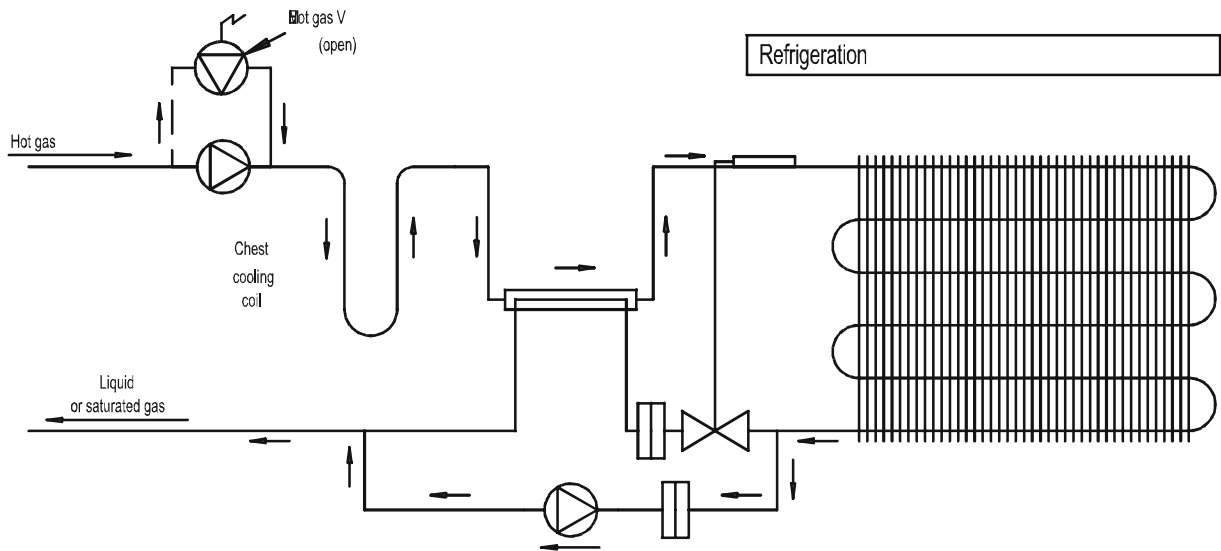
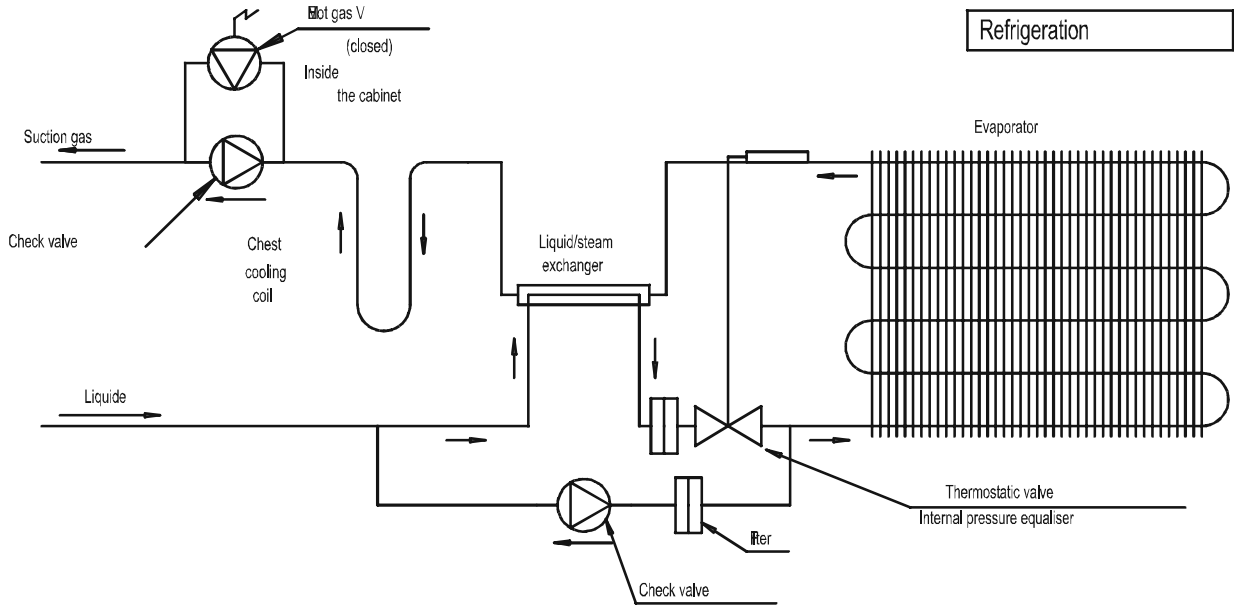

|   |                         |                 |      |      |  |  |
|---|-------------------------|-----------------|------|------|--|--|
| <b>COSTAN</b> TECHNICAL<br>DOCUMENTATION<br><br>PRODUCT: ELEPHANT GV<br>CHAP. No. 9      N° DOC. QSM000095E<br>CHAPTER: WIRING DIAGRAMS | CHAPTER REVISION STATUS |                 |      |      | IN CONFORMITY<br>WITH APPROVED<br>ORIGINAL | PAGE: <b>1/14</b>                      |
|   | ORD.                    | DATE            | ORD. | DATE |  | DATE of 1st ISSUE:<br><b>21.Jan.04</b> |
|   | A                       | <b>20.07.04</b> | D    |      |  | ISSUED BY<br><b>MKT</b>                |
|   | B                       |                 | E    |      |  |  |
| C   |                         | F               |      |      |  |  |

---

# WIRING DIAGRAMS

---

| ORD. | DATE     | ORD. | DATE |
|------|----------|------|------|
| A    | 20.07.04 | D    |      |
| B    |          | E    |      |
| C    |          | F    |      |

READING PRINCIPLE OF WIRING DIAGRAM

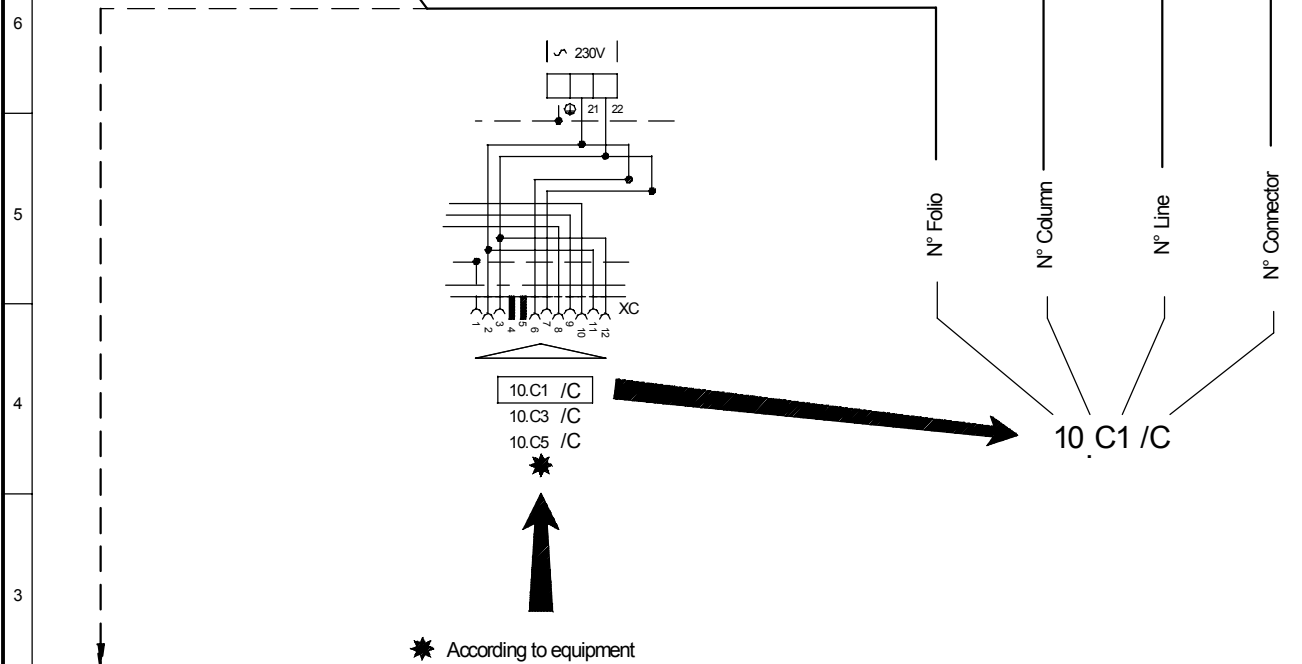
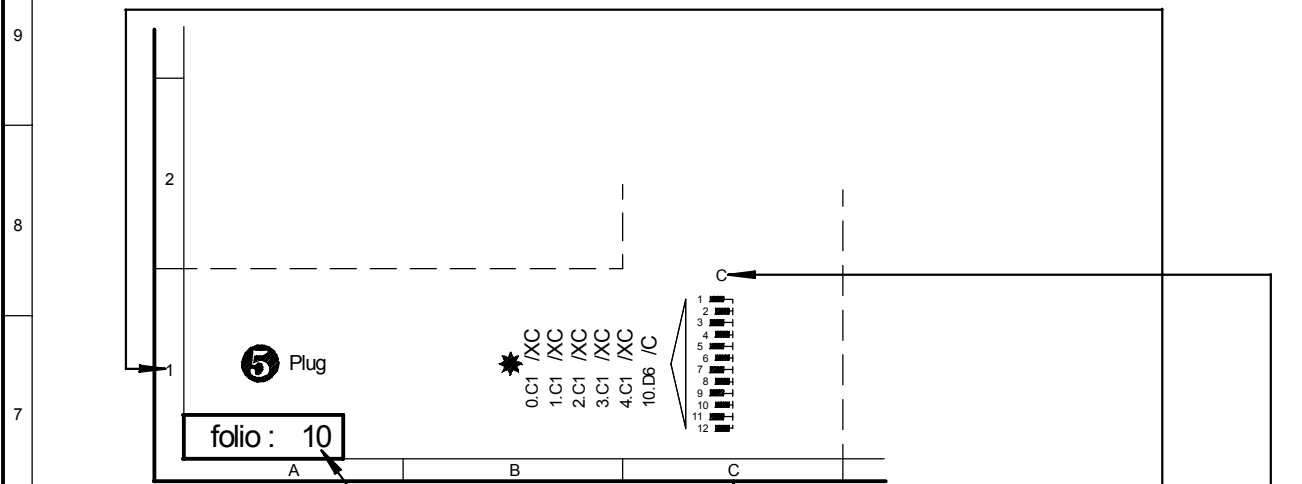

Paging of folios

| N° Folio | 0.....9            | 50.....69 | 10..               | ..49 |
|----------|--------------------|-----------|--------------------|------|
| Function | Outside connection |           | Cabinet components |      |

| ORD. | DATE     | ORD. | DATE |
|------|----------|------|------|
| A    | 20.07.04 | D    |      |
| B    |          | E    |      |
| C    |          | F    |      |

### CABINET TERMINAL STRIP WIRING DIAGRAM

★ According to equipment

① Lights power supply

⑤ Alarm clean contact

② Demist heater

⑥ Defrost start signal

③ Fan + controller power supply

⑦ Defrost heater power supply

④ Solenoid valve

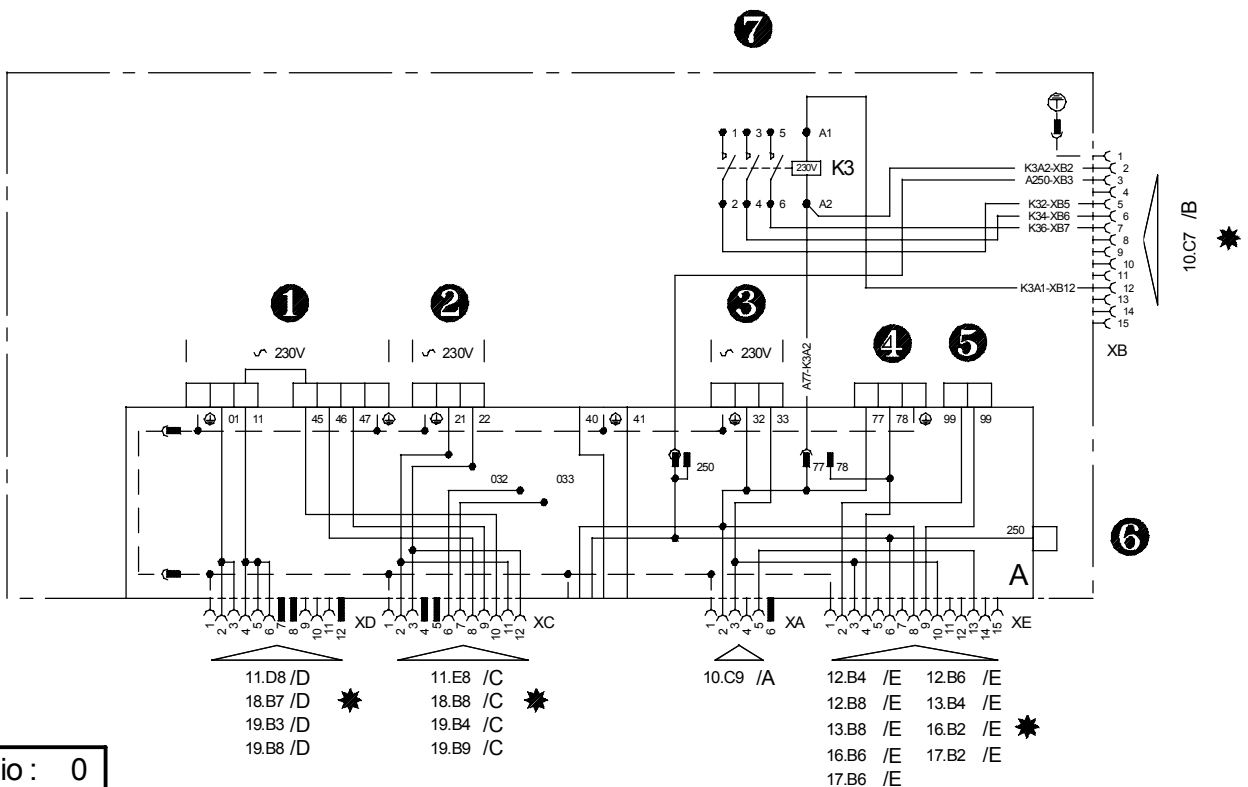

folio : 0

| ORD. | DATE     | ORD. | DATE |
|------|----------|------|------|
| A    | 20.07.04 | D    |      |
| B    |          | E    |      |
| C    |          | F    |      |

**SRTS 3 WIRING DIAGRAM**  
 (SAFETY RUN TERMINAL STRIP FOR 3 CABINETS)

★ According to equipment

- 1** Light Remote Control signal 24V AC
- 3** Defrost start signal (250)
- 5** Thermostat signal (77-78)
- 2** Power supply 400V AC
- 4** Alarm clean contact (99-99)

9

8

7

6

5

4

3

2

1

folio: 1

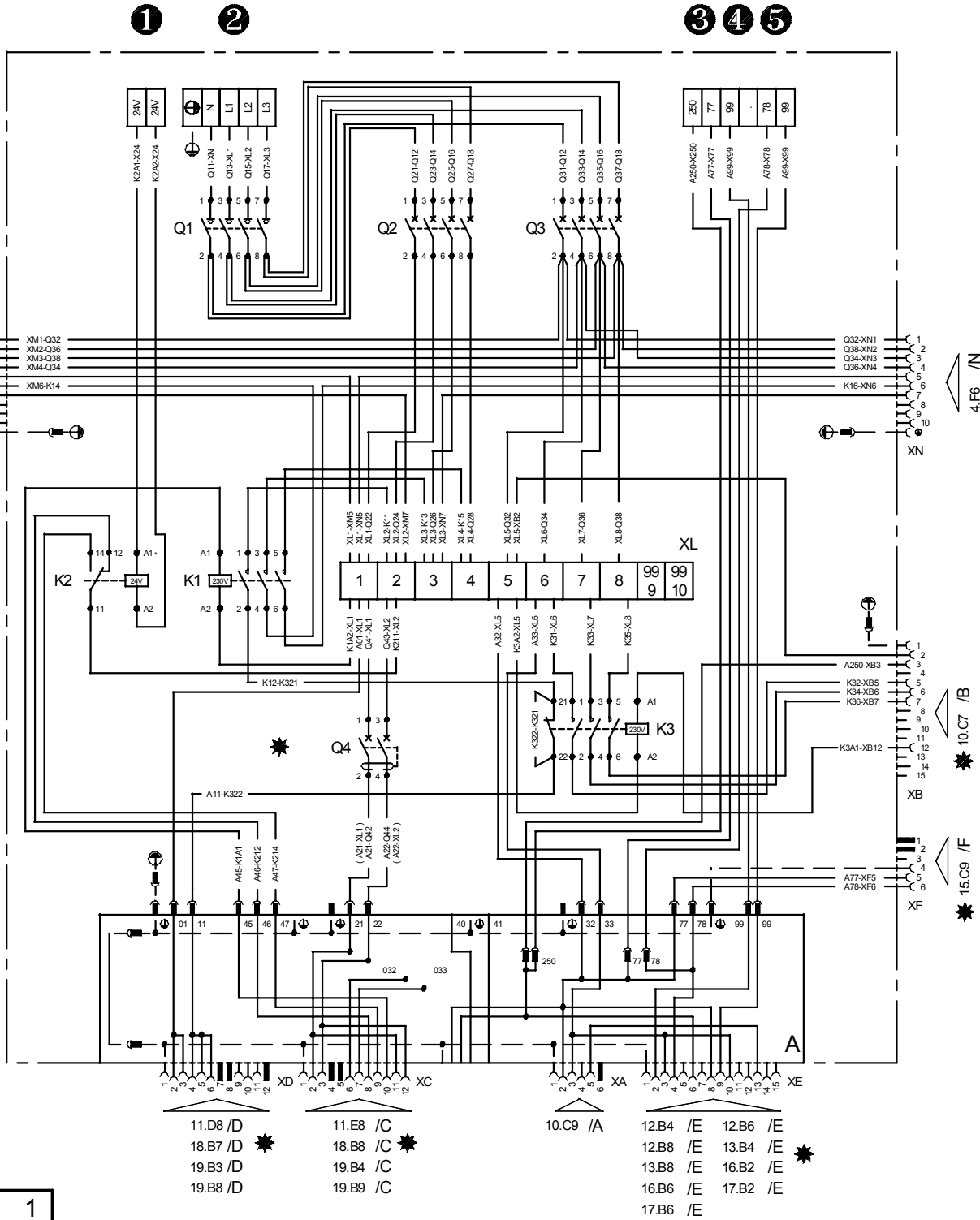

A B C D E F

- 11.D8 /D
- 11.E8 /C
- 12.B4 /E
- 12.B6 /E
- 18.B7 /D
- 18.B8 /C
- 12.B8 /E
- 13.B4 /E
- 19.B3 /D
- 19.B4 /C
- 13.B8 /E
- 16.B2 /E
- 19.B8 /D
- 19.B9 /C
- 16.B6 /E
- 17.B2 /E
- 10.C9 /A
- 12.B4 /E
- 17.B6 /E

| ORD. | DATE     | ORD. | DATE |
|------|----------|------|------|
| A    | 20.07.04 | D    |      |
| B    |          | E    |      |
| C    |          | F    |      |

**SRTS 2 WIRING DIAGRAM**  
 (SAFETY RUN TERMINAL STRIP FOR 2 CABINETS)

★ According to equipment

- ❶ Light Remote Control signal 24V AC
- ❷ Power supply 400V AC
- ❸ Defrost start signal (250)
- ❹ Alarm clean contact (99-99)
- ❺ Thermostat signal (77-78)

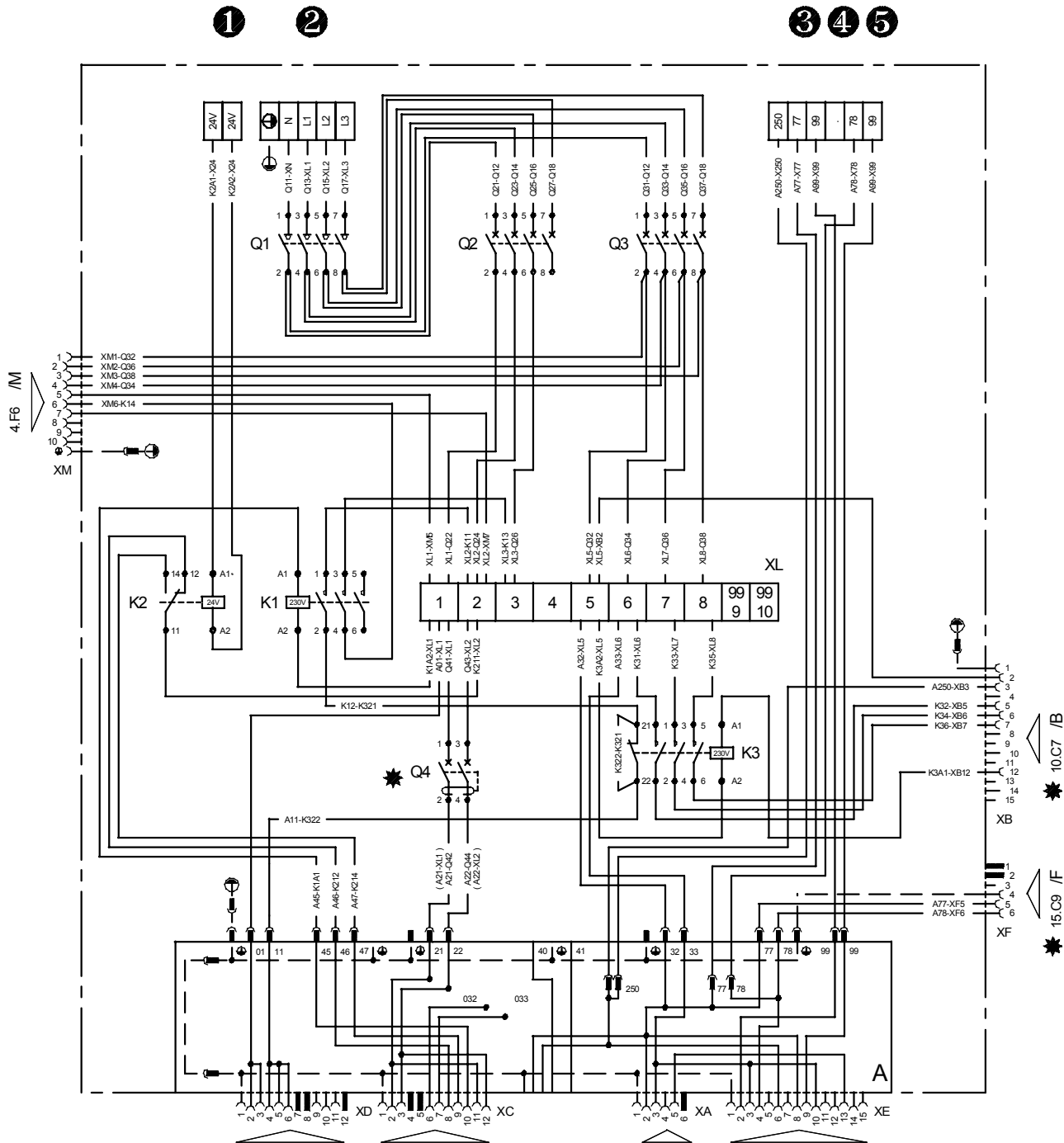

- |          |   |          |   |          |          |          |
|----------|---|----------|---|----------|----------|----------|
| 11.D8 /D | ★ | 11.E8 /C | ★ | 10.C9 /A | 12.B4 /E | 12.B6 /E |
| 18.B7 /D | ★ | 18.B8 /C | ★ | 12.B8 /E | 13.B4 /E | ★        |
| 19.B3 /D |   | 19.B4 /C |   | 13.B8 /E | 16.B2 /E |          |
| 19.B8 /D |   | 19.B9 /C |   | 16.B6 /E | 17.B2 /E |          |
|          |   |          |   | 17.B6 /E |          |          |

| ORD. | DATE     | ORD. | DATE |
|------|----------|------|------|
| A    | 20.07.04 | D    |      |
| B    |          | E    |      |
| C    |          | F    |      |

**SRTS 1 WIRING DIAGRAM**  
 (SAFETY RUN TERMINAL STRIP FOR 1 CABINET)

\* According to equipment

- 1** Light Remote Control signal 24V AC
- 3** Defrost start signal (250)
- 5** Thermostat signal (77-78)
- 2** Power supply 400V AC
- 4** Alarm clean contact (99-99)

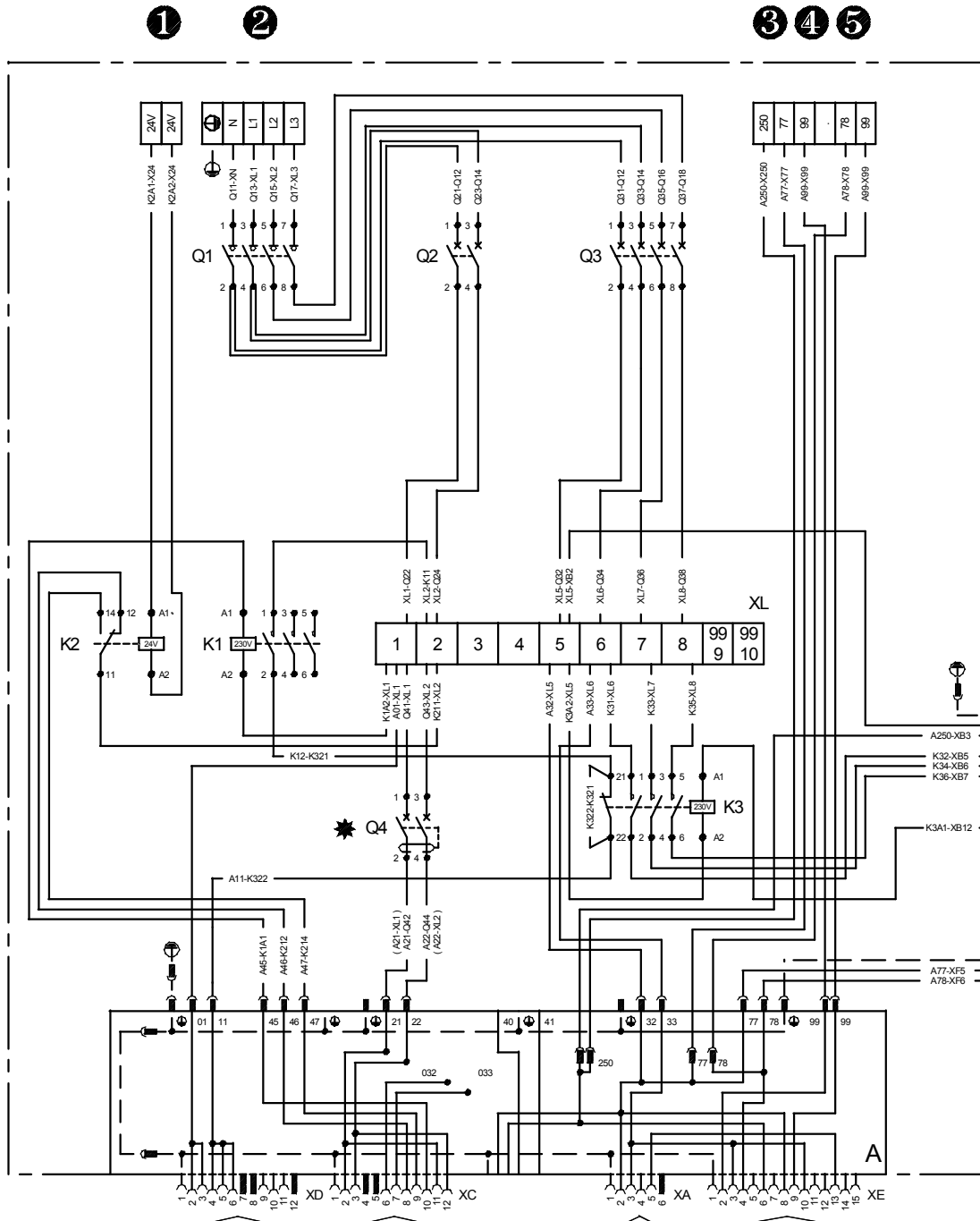

folio : 3

- 11.D8 /D \*
- 18.B7 /D \*
- 19.B3 /D
- 19.B8 /D
- 11.E8 /C \*
- 18.B8 /C \*
- 19.B4 /C
- 19.B9 /C
- 10.C9 /A
- 12.B4 /E
- 12.B8 /E
- 13.B8 /E
- 16.B6 /E
- 17.B6 /E
- 12.B6 /E
- 13.B4 /E
- 16.B2 /E \*
- 17.B2 /E

9  
8  
7  
6  
5  
4  
3  
2  
1

A B C D E F

| ORD. | DATE     | ORD. | DATE |
|------|----------|------|------|
| A    | 20.07.04 | D    |      |
| B    |          | E    |      |
| C    |          | F    |      |

**FTB WIRING DIAGRAM**  
 (FINAL TERMINAL STRIP)

★ According to equipment

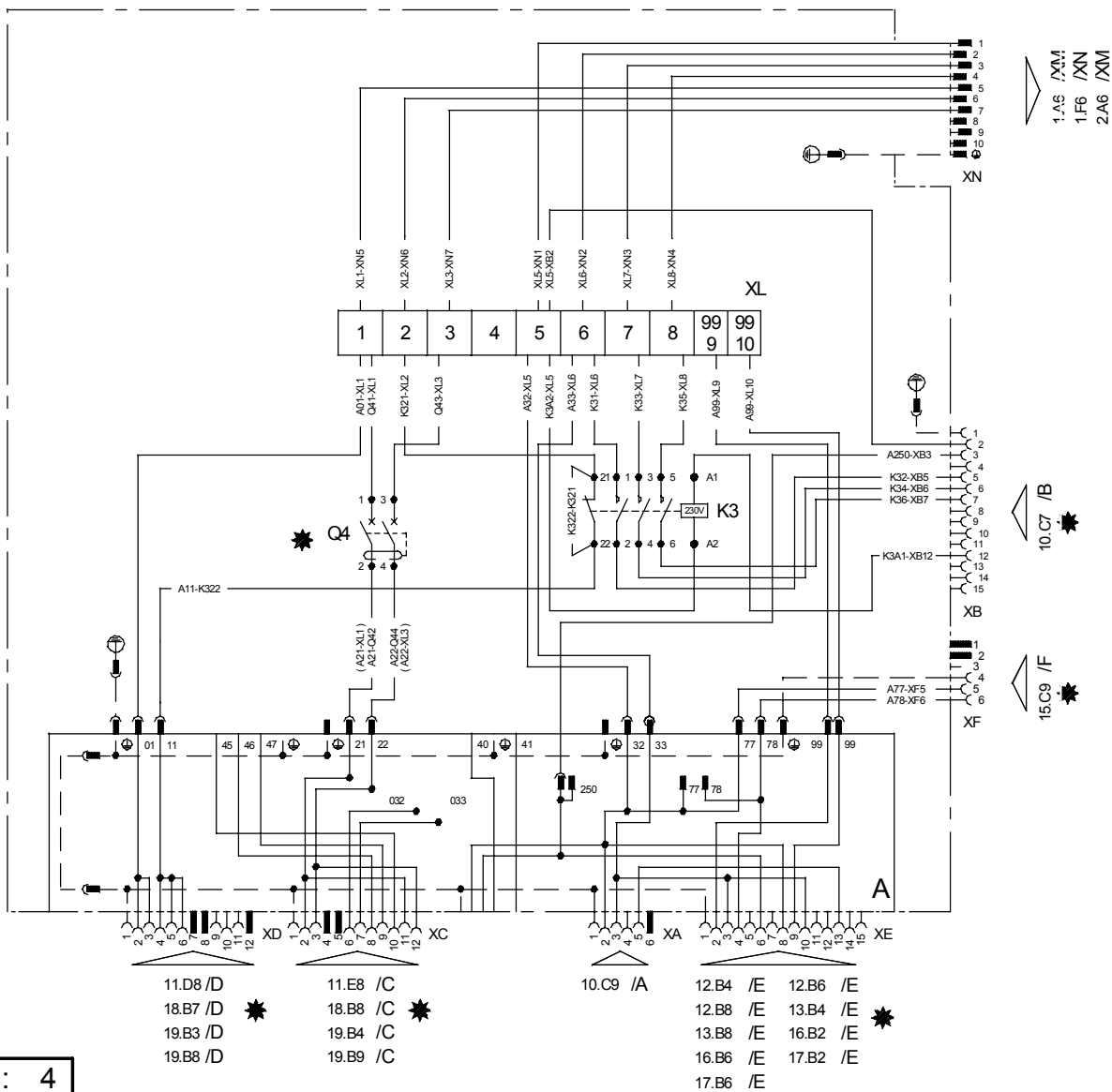

1.A5 /XM  
 1.F6 /XN  
 2.A6 /XM

10.C7 /B ★

15.C9 /F ★

- |            |            |          |          |            |
|------------|------------|----------|----------|------------|
| 11.D8 /D   | 11.E8 /C   | 10.C9 /A | 12.B4 /E | 12.B6 /E   |
| 18.B7 /D ★ | 18.B8 /C ★ |          | 12.B8 /E | 13.B4 /E ★ |
| 19.B3 /D   | 19.B4 /C   |          | 13.B8 /E | 16.B2 /E   |
| 19.B8 /D   | 19.B9 /C   |          | 16.B6 /E | 17.B2 /E   |
|            |            |          | 17.B6 /E |            |

| ORD. | DATE     | ORD. | DATE |
|------|----------|------|------|
| A    | 20.07.04 | D    |      |
| B    |          | E    |      |
| C    |          | F    |      |

**WIRING DIAGRAM (FANS/DEFROST/SAFETY THERMOSTAT)**

★ According to equipment

**1** 1R Fans

- 0.D1 /XA
- 1.D1 /XA
- 2.D1 /XA
- 3.D1 /XA
- 4.D1 /XA
- 50.D1 /XA
- 51.D1 /XA
- 52.D1 /XA
- 53.D1 /XA
- 54.D1 /XA

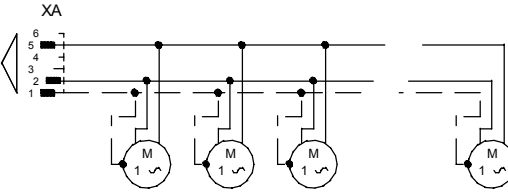

**2** Electrical Defrost

★

- 0.F3 /XB
- 1.F4 /XB
- 2.F4 /XB
- 3.F4 /XB
- 4.F4 /XB
- 50.F4 /XB
- 51.F4 /XB
- 52.F4 /XB
- 53.F4 /XB
- 54.F4 /XB

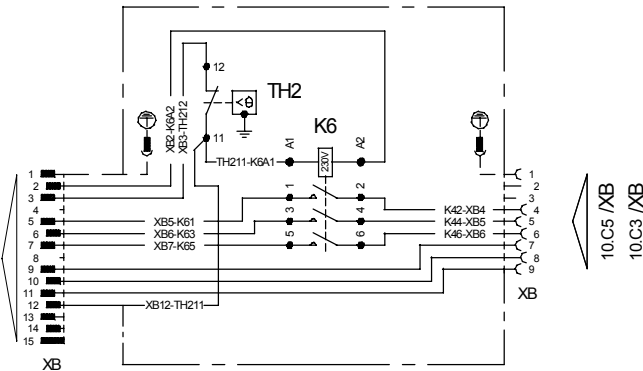

**3** Defrost heater 3Ph 400V

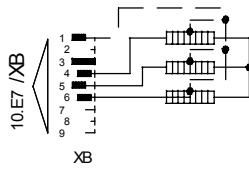

**4** Defrost heater 1Ph 230V or 3Ph 400V + neutral

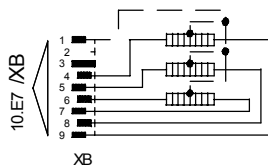

**5** Hot gaz EMV

★

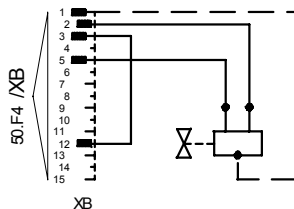

| ORD. | DATE     | ORD. | DATE |
|------|----------|------|------|
| A    | 20.07.04 | D    |      |
| B    |          | E    |      |
| C    |          | F    |      |

|                                 |
|---------------------------------|
| DATE of 1st ISSUE:<br>21.Jan.04 |
| ISSUED BY<br>MKT                |

WIRING DIAGRAM (LIGHT Ø26 FERROMAGNETIC / HEATERS)

- ★ According to equipment
- 1-Optional thermostat
- 2-Positive application
- 3-Glassed end panel

- |          |           |          |           |
|----------|-----------|----------|-----------|
| 0.B1 /XD | 50.B1 /XD | 0.C1 /XC | 50.C1 /XC |
| 1.B1 /XD | 51.B1 /XD | 1.C1 /XC | 51.C1 /XC |
| 2.B1 /XD | 52.B1 /XD | 2.C1 /XC | 52.C1 /XC |
| 3.B1 /XD | 53.B1 /XD | 3.C1 /XC | 53.C1 /XC |
| 4.B1 /XD | 54.B1 /XD | 4.C1 /XC | 54.C1 /XC |

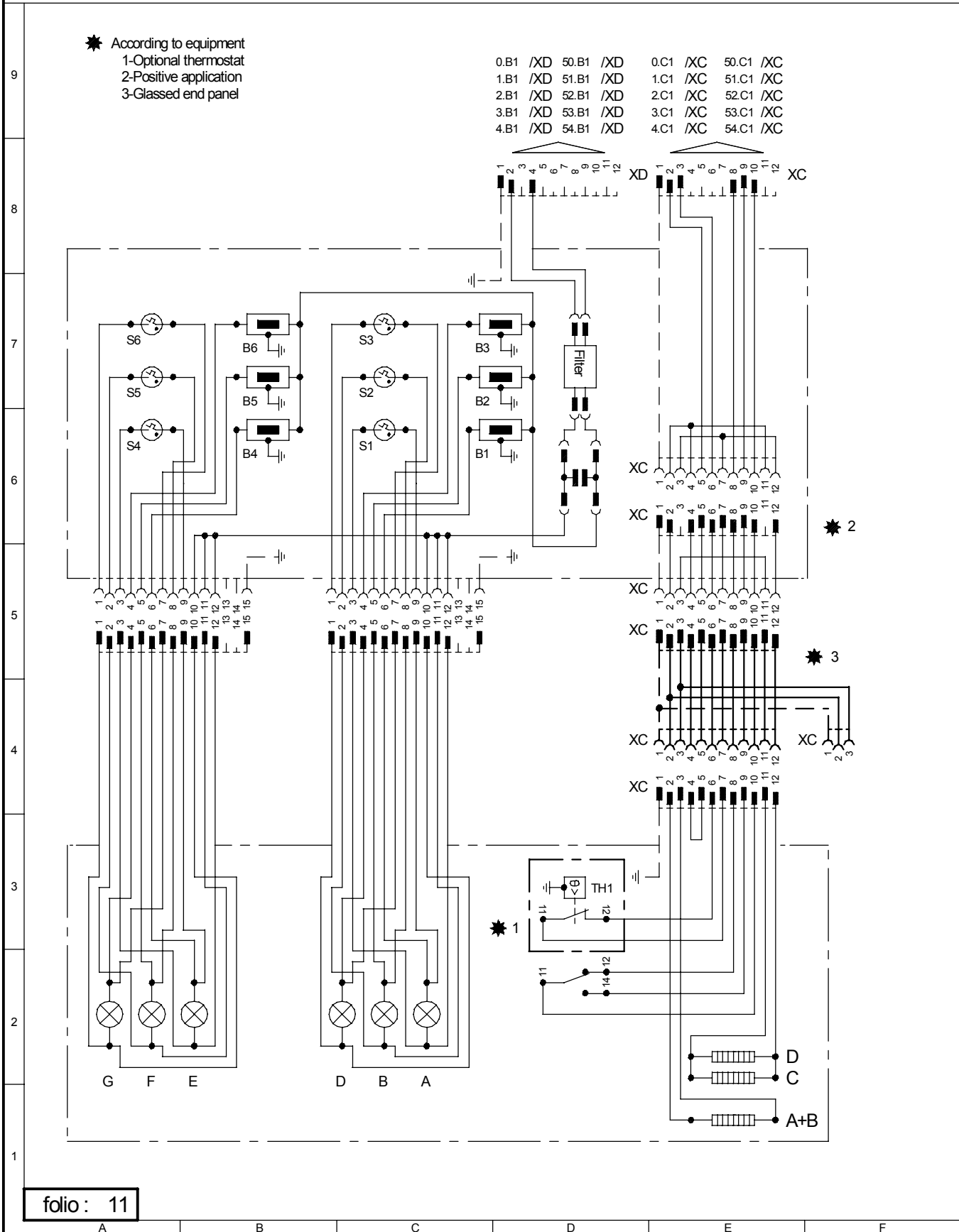

### WIRING DIAGRAM (EKC201)

★ According to equipment

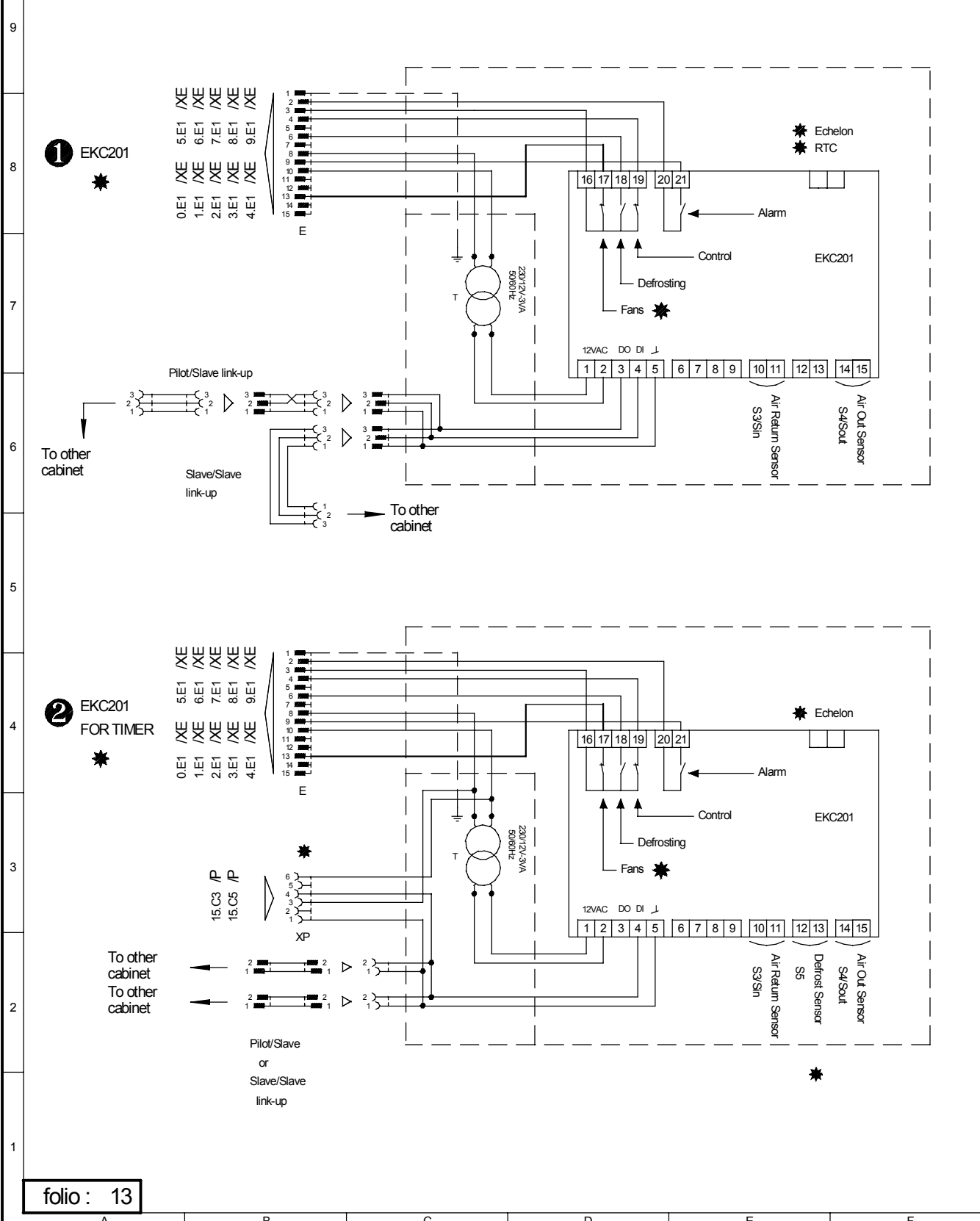

| ORD. | DATE     | ORD. | DATE |
|------|----------|------|------|
| A    | 20.07.04 | D    |      |
| B    |          | E    |      |
| C    |          | F    |      |

WIRING DIAGRAM (EMV AC-DC/DEF.RELAY/TIMER)

★ According to equipment

9 **1** EMV AC ★

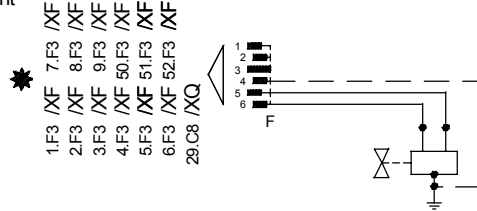

7 **2** EMV DC ★

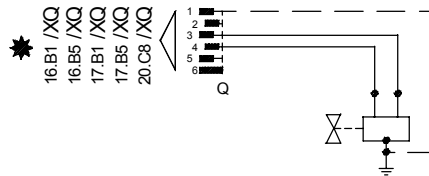

5 **3** START DEFROST RELAY ★

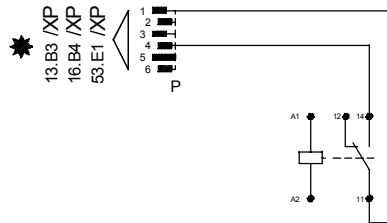

3 **4** TIMER ★

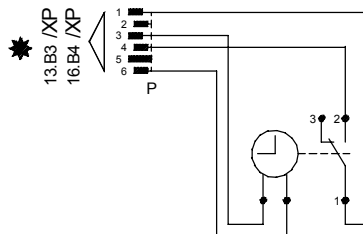

| ORD. | DATE     | ORD. | DATE |
|------|----------|------|------|
| A    | 20.07.04 | D    |      |
| B    |          | E    |      |
| C    |          | F    |      |

WIRING DIAGRAM (EKC414A)

★ According to equipment

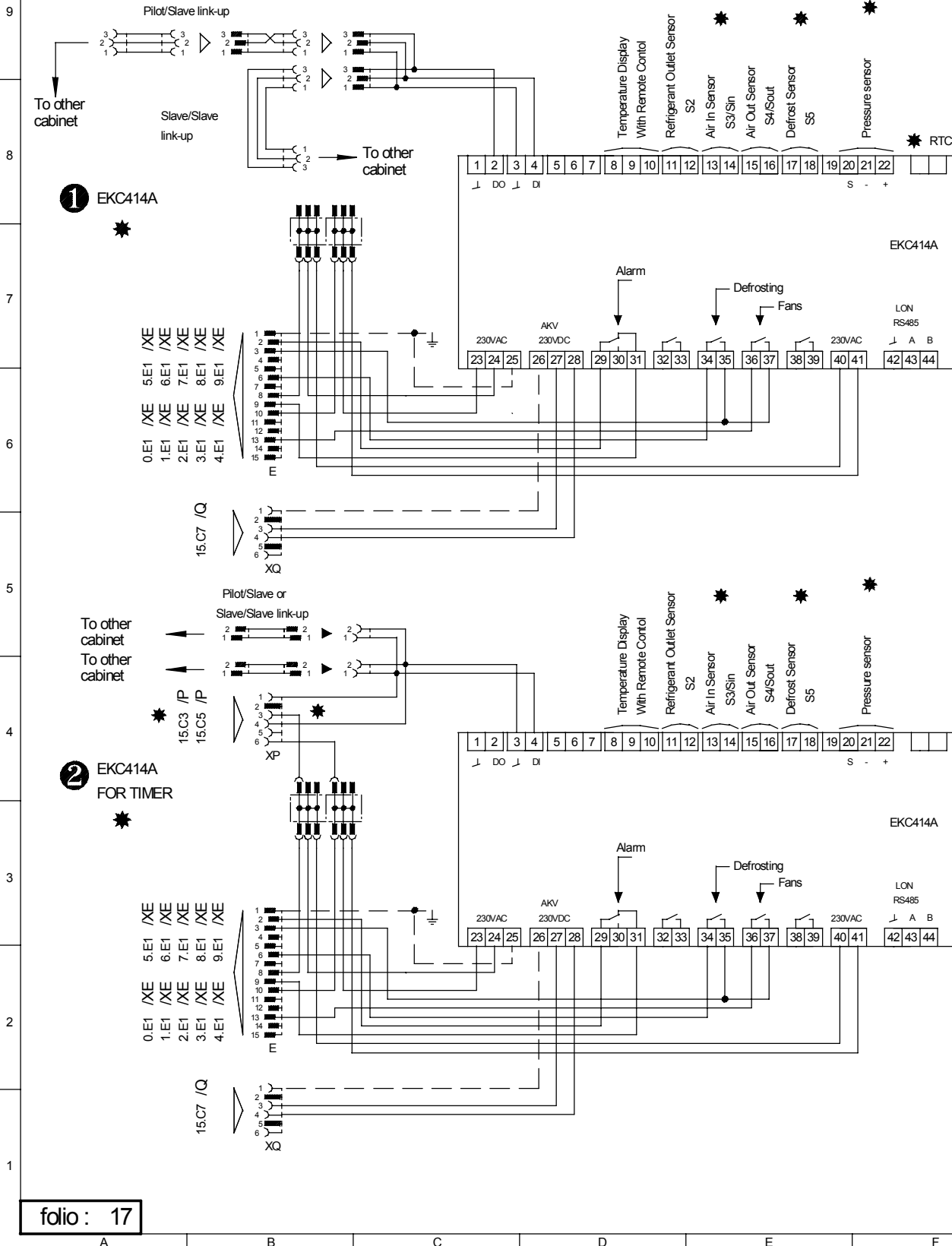

| ORD. | DATE     | ORD. | DATE |
|------|----------|------|------|
| A    | 20.07.04 | D    |      |
| B    |          | E    |      |
| C    |          | F    |      |

|                                 |
|---------------------------------|
| DATE of 1st ISSUE:<br>21.Jan.04 |
| ISSUED BY<br>MKT                |

WIRING DIAGRAM (LIGHT Ø16 ELECTRONIC / HEATERS)

- \* According to equipment
- 1-Optional thermostat
- 2-Positive application
- 3-Glassed end panel

- 0.B1 /XD 50.B1 /XD 0.C1 /XC 50.C1 /XC
- 1.B1 /XD 51.B1 /XD 1.C1 /XC 51.C1 /XC
- 2.B1 /XD 52.B1 /XD 2.C1 /XC 52.C1 /XC
- 3.B1 /XD 53.B1 /XD 3.C1 /XC 53.C1 /XC
- 4.B1 /XD 4.C1 /XC

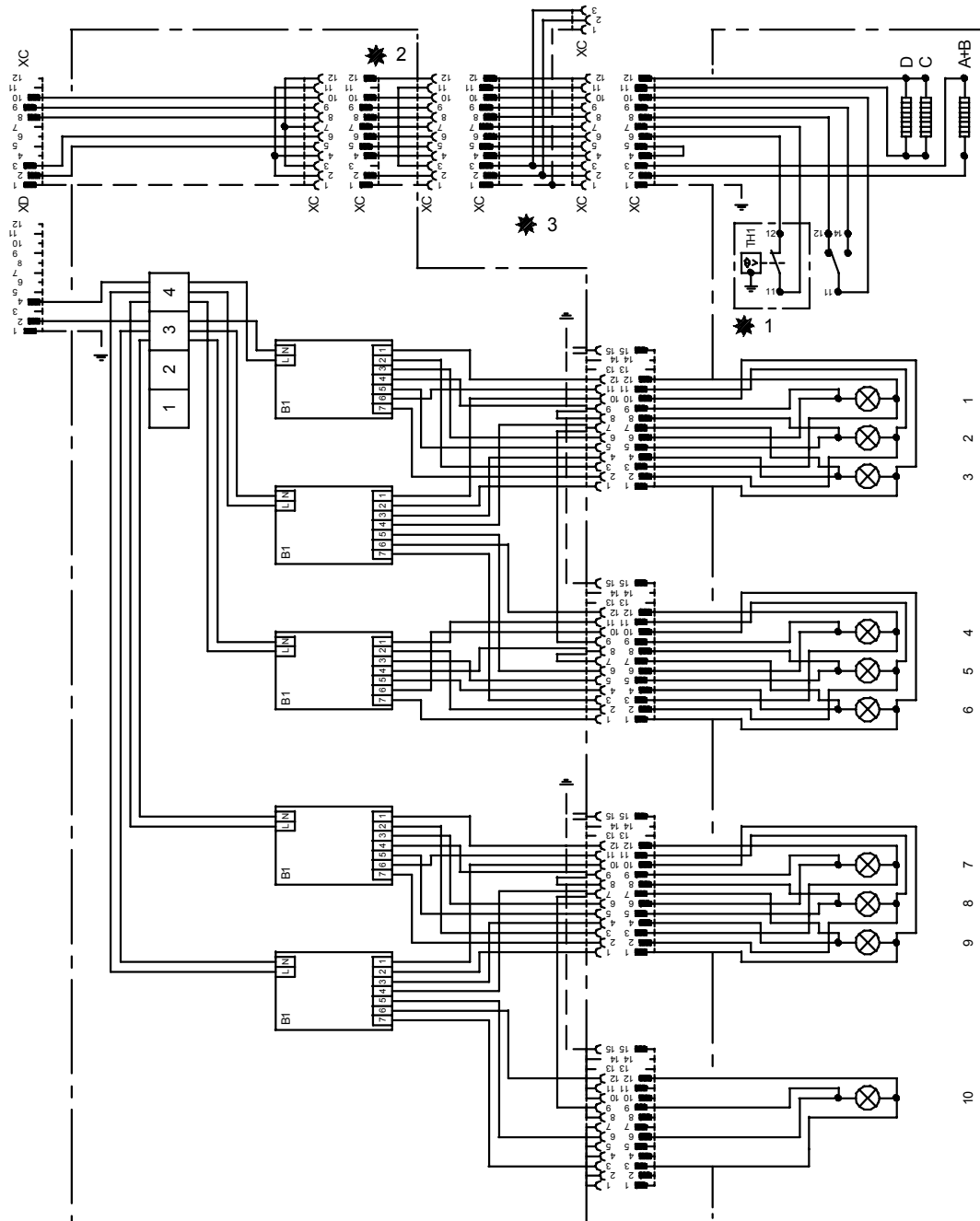

| ORD. | DATE     | ORD. | DATE |
|------|----------|------|------|
| A    | 20.07.04 | D    |      |
| B    |          | E    |      |
| C    |          | F    |      |

WIRING DIAGRAM (LIGHT Ø26 ELECTRONIC / HEATERS)

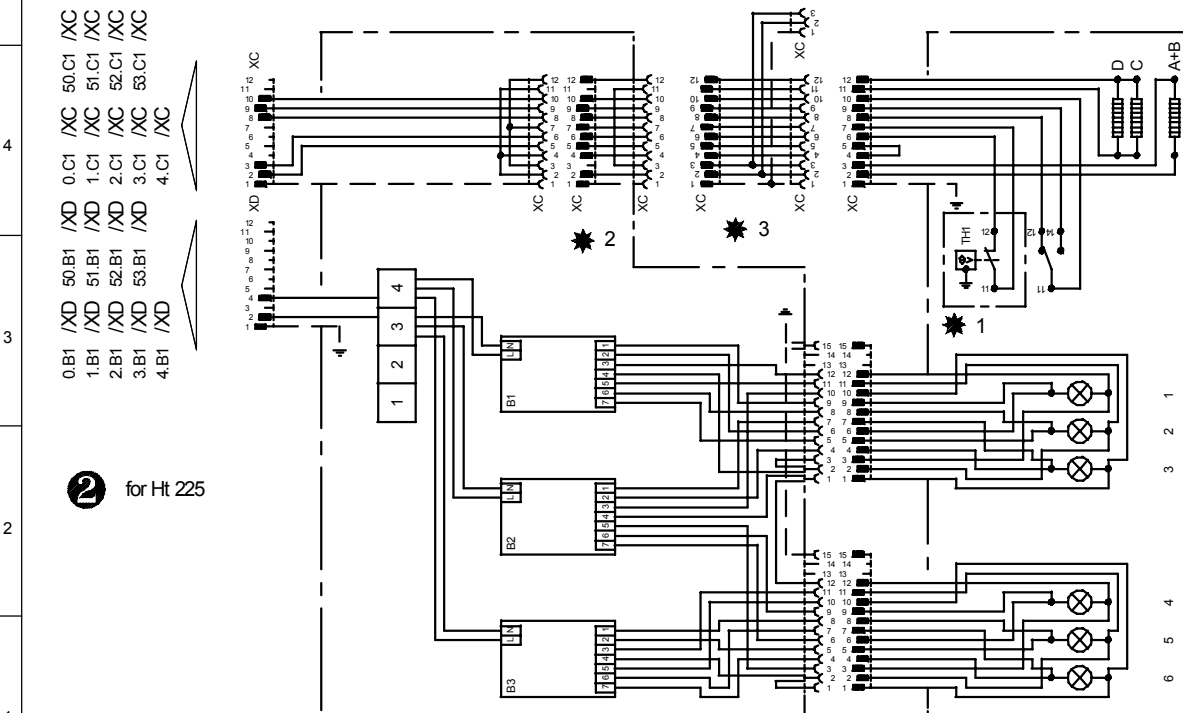
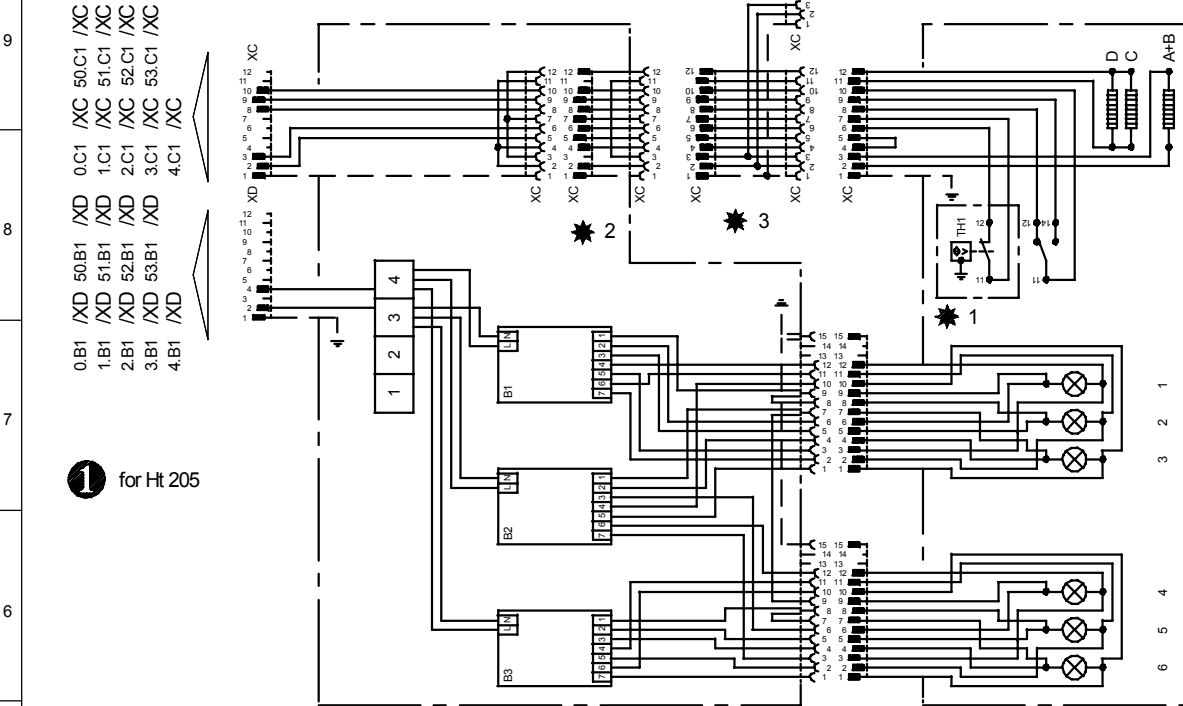

|   |                         |      |      |      |                                      |  |
|---|-------------------------|------|------|------|--------------------------------------|--|
| <b>COSTAN</b> TECHNICAL DOCUMENTATION   | CHAPTER REVISION STATUS |      |      |      | IN CONFORMITY WITH APPROVED ORIGINAL | PAGE: <b>1/6</b>                       |
|   | ORD.                    | DATE | ORD. | DATE |                                      | DATE of 1st ISSUE:<br><b>21.Jan.04</b> |
| PRODUCT: ELEPHANT GV<br>CHAP. no. 10 N° DOC. QSM000095E<br>CHAPTER: MULTIPLEXING CABINETS | A                       |      | D    |      | ISSUED BY<br><b>MKT</b>              |  |
|   | B                       |      | E    |      |                                      |  |
|   | C                       |      | F    |      |                                      |  |

# MULTIPLEXING CABINETS

## UNPACK THE CABINETS

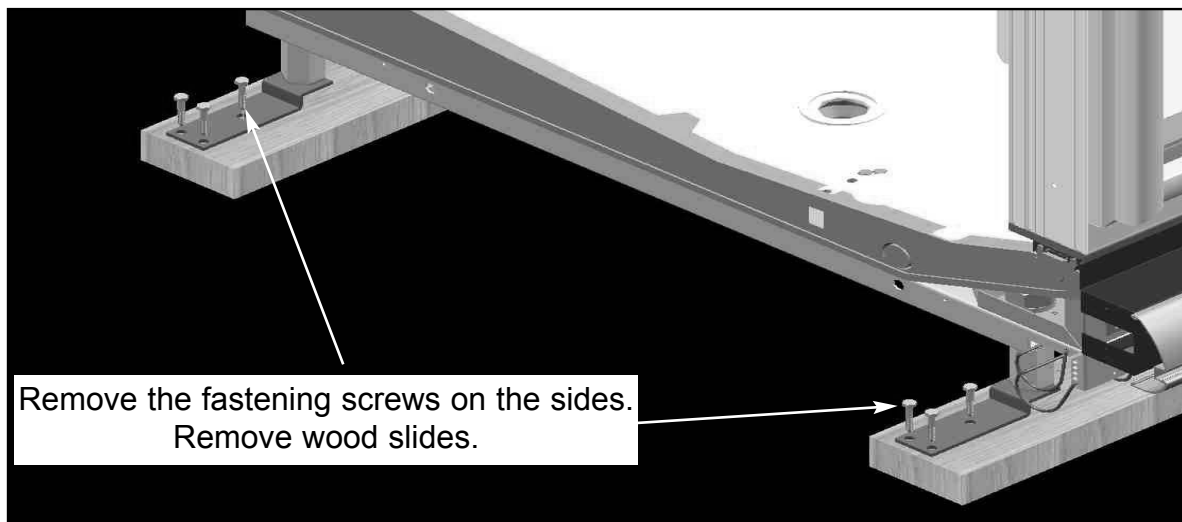
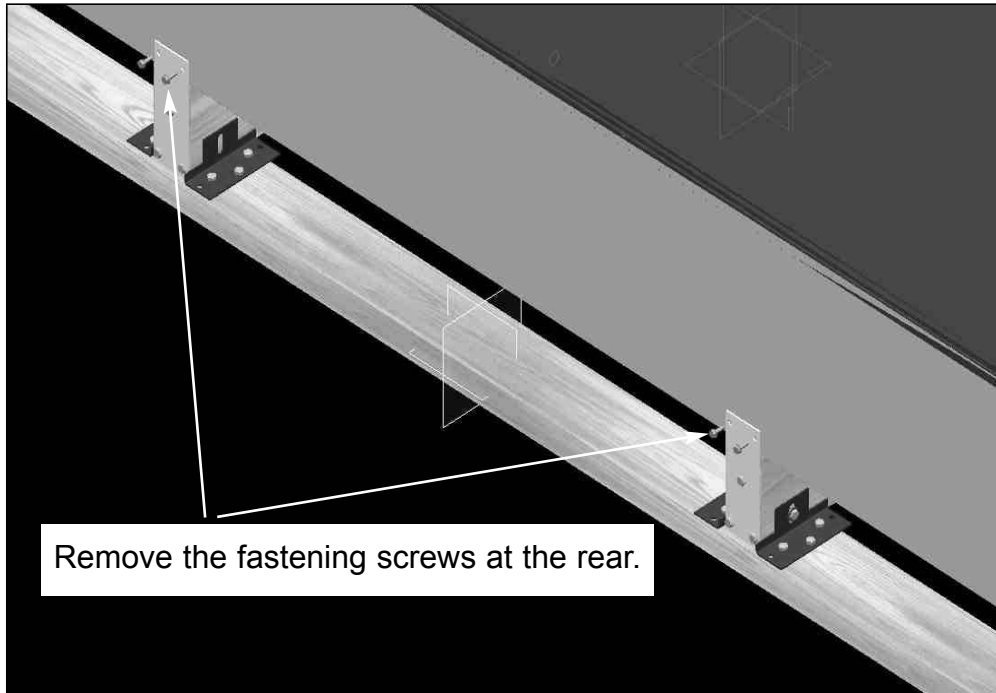

|  |                         |      |      |      |                                      |  |
|--|-------------------------|------|------|------|--------------------------------------|--|
| <b>COSTAN</b> TECHNICAL DOCUMENTATION          | CHAPTER REVISION STATUS |      |      |      | IN CONFORMITY WITH APPROVED ORIGINAL | PAGE: <b>2/6</b>                       |
|  | ORD.                    | DATE | ORD. | DATE |                                      | DATE of 1st ISSUE:<br><b>21.Jan.04</b> |
| PRODUCT: ELEPHANT GV                           | A                       |      | D    |      |                                      | ISSUED BY<br><b>MKT</b>                |
| CHAP. No. <b>10</b> DOC. no. <b>QSM000095E</b> | B                       |      | E    |      |                                      |  |
| CHAPTER: <b>MULTIPLEXING CABINETS</b>          | C                       |      | F    |      |                                      |  |

## LEVEL THE CABINET

Remove bottom plates.

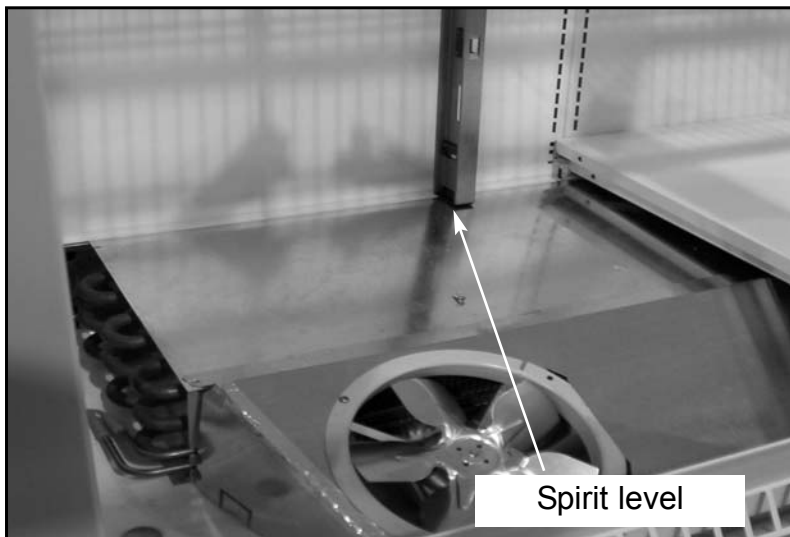
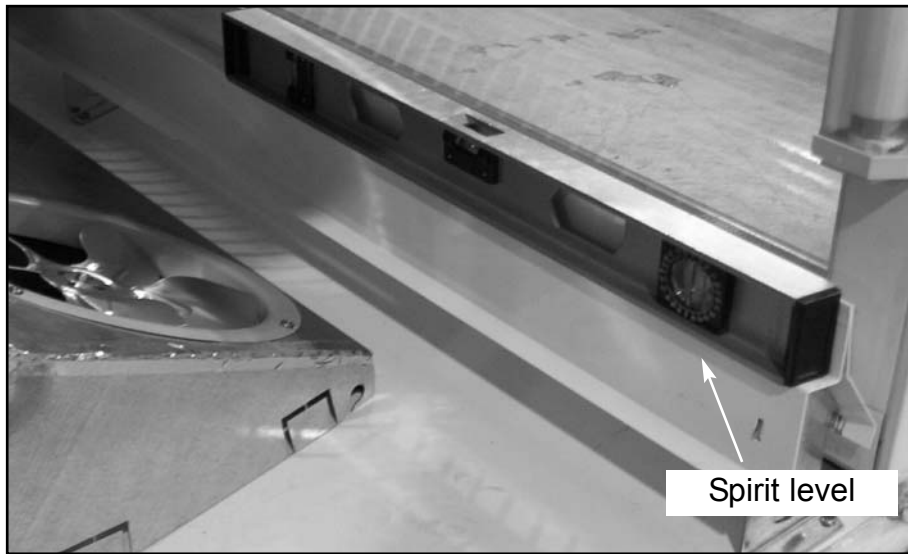
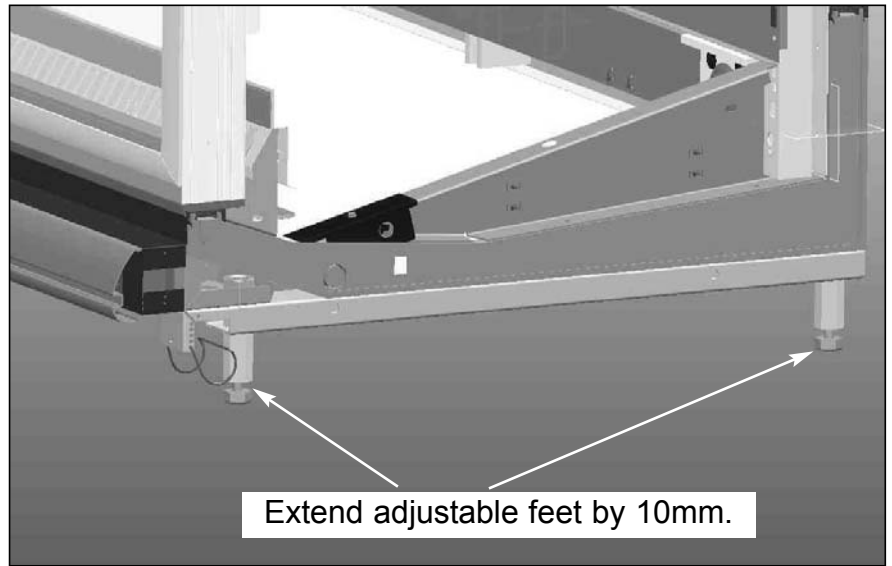

Raise fore feet further 5mm so that the cabinet slants backwards.

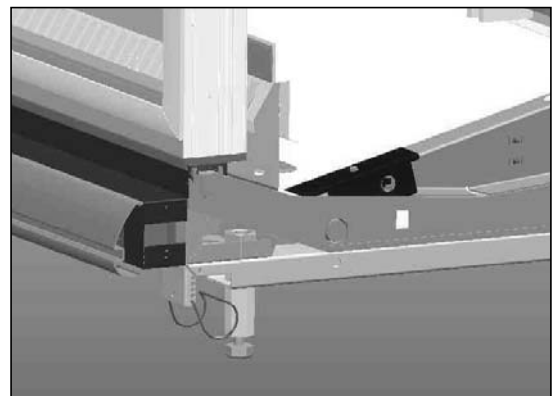

|   |                         |      |      |      |                                      |  |
|---|-------------------------|------|------|------|--------------------------------------|--|
| <b>COSTAN</b> TECHNICAL DOCUMENTATION   | CHAPTER REVISION STATUS |      |      |      | IN CONFORMITY WITH APPROVED ORIGINAL | PAGE: <b>3/6</b>                       |
|   | ORD.                    | DATE | ORD. | DATE |                                      | DATE of 1st ISSUE:<br><b>21.Jan.04</b> |
| PRODUCT: ELEPHANT GV<br>CHAP. no. 10 N° DOC. QSM000095E<br>CHAPTER: MULTIPLEXING CABINETS | A                       |      | D    |      | ISSUED BY<br><b>MKT</b>              |  |
|   | B                       |      | E    |      |                                      |  |
|   | C                       |      | F    |      |                                      |  |

## APPLY SPONGE RUBBER

Apply sponge rubber onto one of the cabinets to be coupled as shown in the drawing.

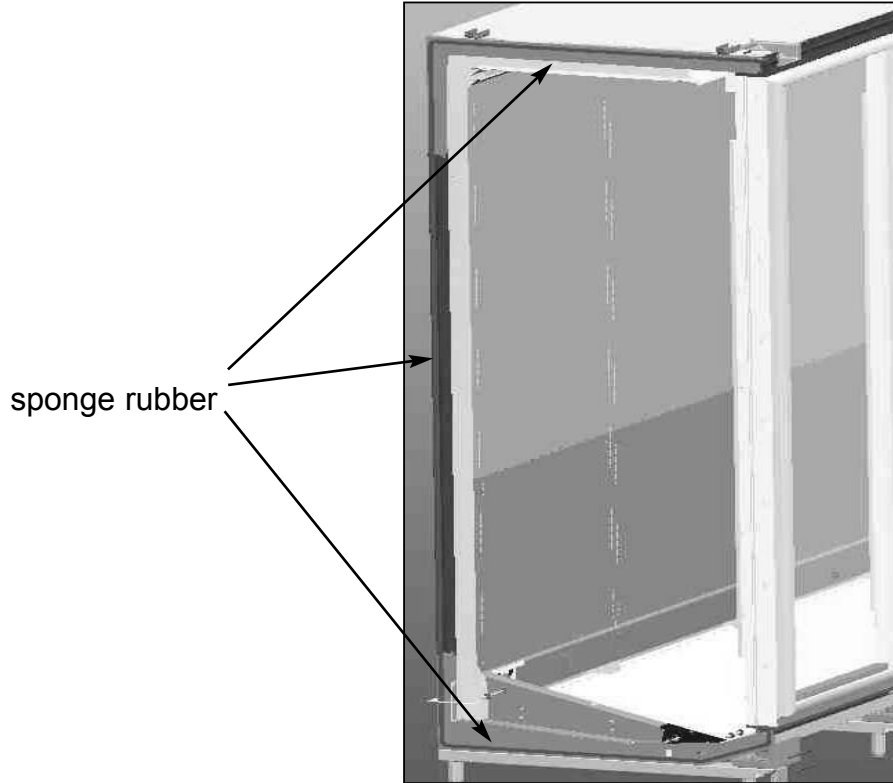

## PLACE ALIGNMENT PINS

Insert two alignment pins into the canopy of one of the cabinets to be coupled.  
Insert both plastic alignment joints in the steel bumper rail of one of the cabinets to be coupled.

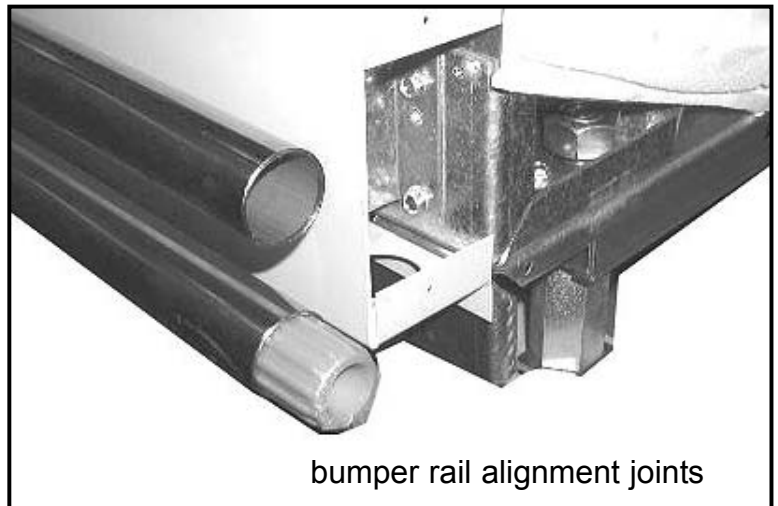
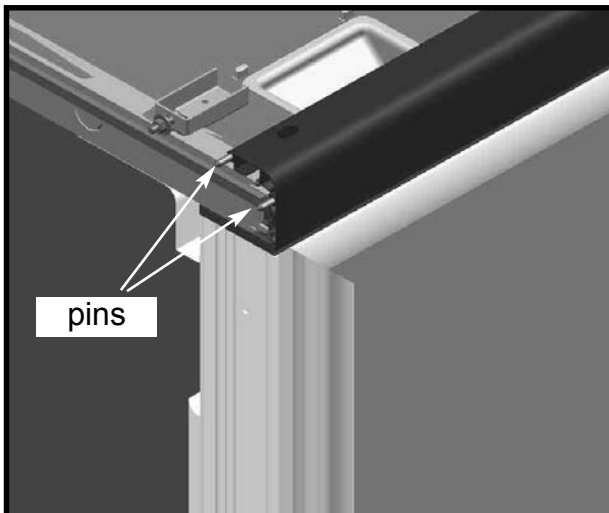

|  |                         |      |      |      |                                      |  |
|--|-------------------------|------|------|------|--------------------------------------|--|
| <b>COSTAN</b> TECHNICAL DOCUMENTATION          | CHAPTER REVISION STATUS |      |      |      | IN CONFORMITY WITH APPROVED ORIGINAL | PAGE: <b>4/6</b>                       |
|  | ORD.                    | DATE | ORD. | DATE |                                      | DATE of 1st ISSUE:<br><b>21.Jan.04</b> |
| PRODUCT: ELEPHANT GV                           | A                       |      | D    |      |                                      | ISSUED BY<br><b>MKT</b>                |
| CHAP. No. <b>10</b> DOC. no. <b>QSM000095E</b> | B                       |      | E    |      |                                      |  |
| CHAPTER: MULTIPLEXING CABINETS                 | C                       |      | F    |      |                                      |  |

## BRING THE CABINETS TOGETHER AND FASTEN THEM TO EACH OTHER

Secure the upper parts of the cabinets to each other using the two brackets on the roof plus hex-head bolts and nuts M6x80.

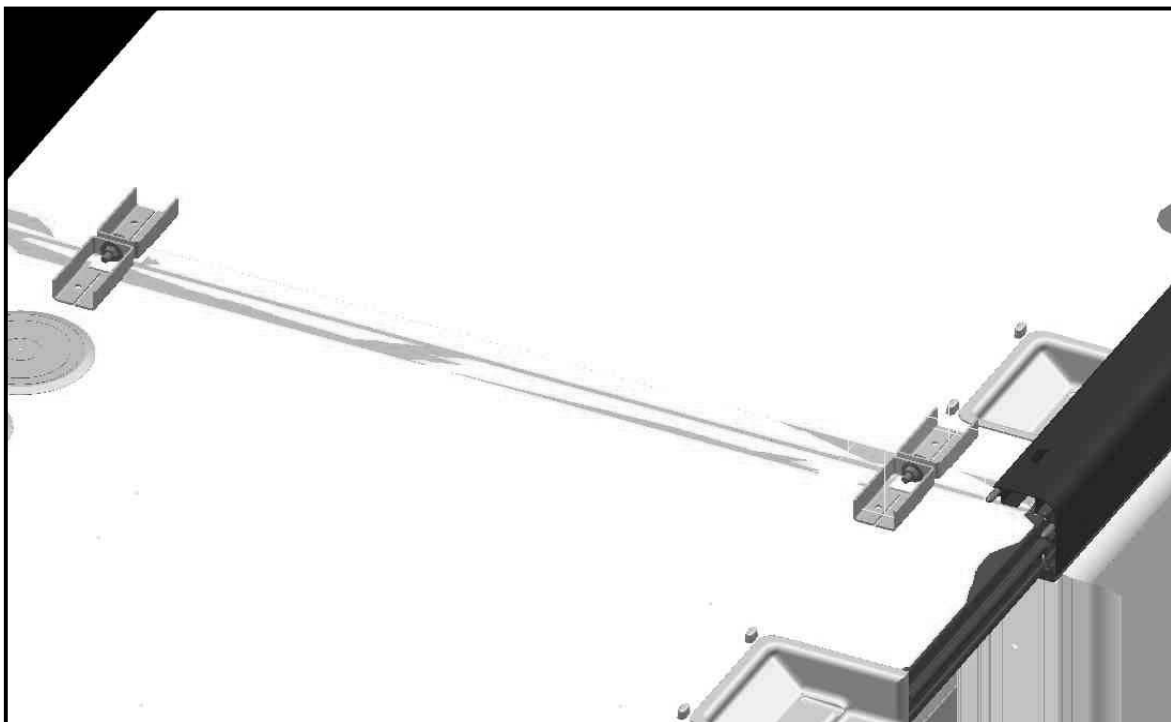
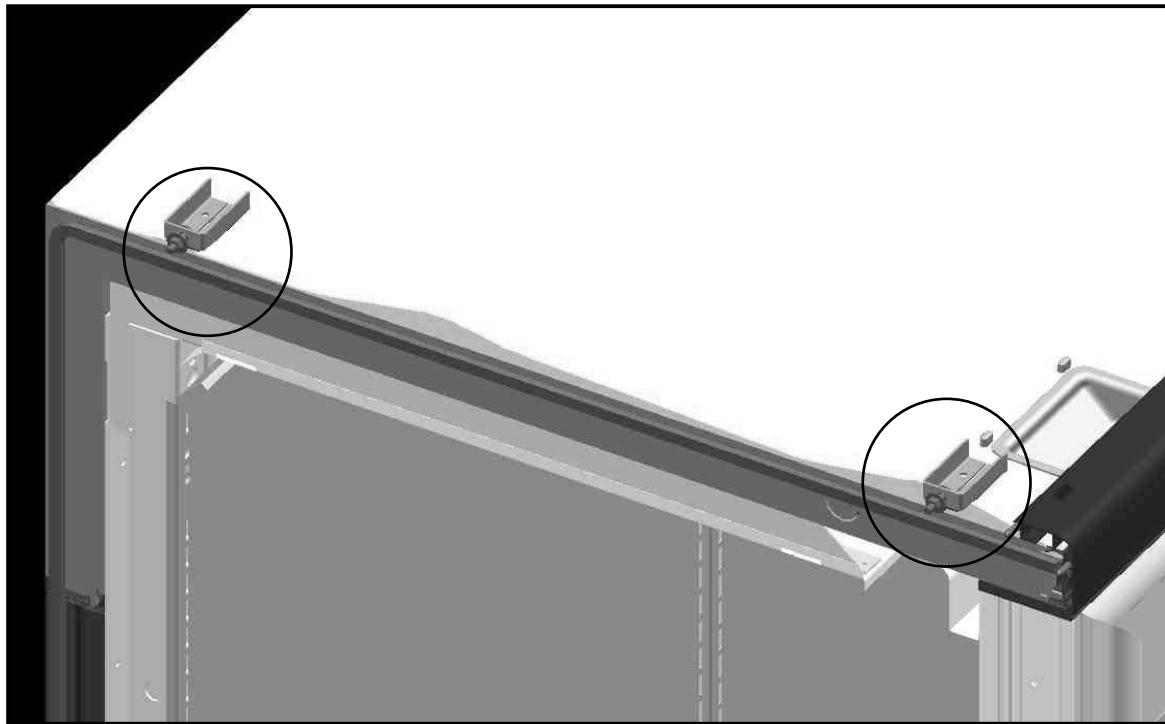

|                                       |                         |      |      |      |                                      |  |
|---------------------------------------|-------------------------|------|------|------|--------------------------------------|--|
| <b>COSTAN</b> TECHNICAL DOCUMENTATION | CHAPTER REVISION STATUS |      |      |      | IN CONFORMITY WITH APPROVED ORIGINAL | PAGE: <b>5/6</b>                       |
|                                       | ORD.                    | DATE | ORD. | DATE |                                      | DATE of 1st ISSUE:<br><b>21.Jan.04</b> |
| PRODUCT: ELEPHANT GV                  | A                       |      | D    |      | ISSUED BY<br><b>MKT</b>              |  |
| CHAP. no. 10 N° DOC. QSM000095E       | B                       |      | E    |      |                                      |  |
| CHAPTER: MULTIPLEXING CABINETS        | C                       |      | F    |      |                                      |  |

Secure the cabinets to each other at the bottom in the three points highlighted in the figure using hex-head bolts and nuts M8x90.

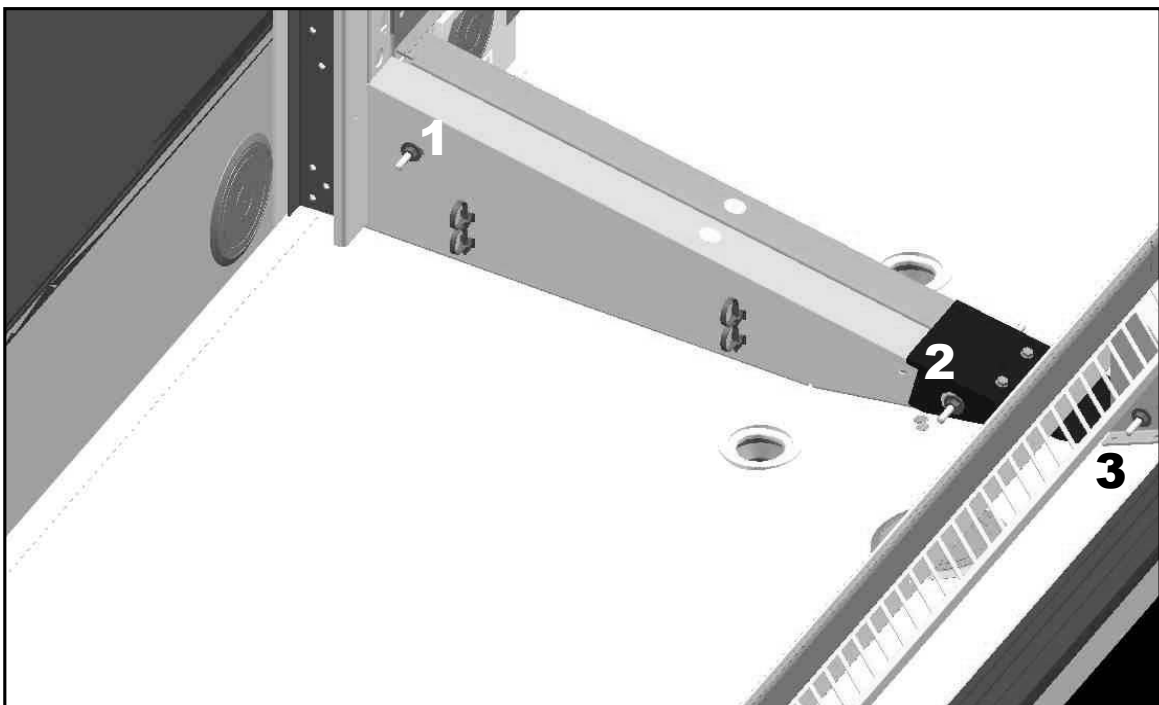
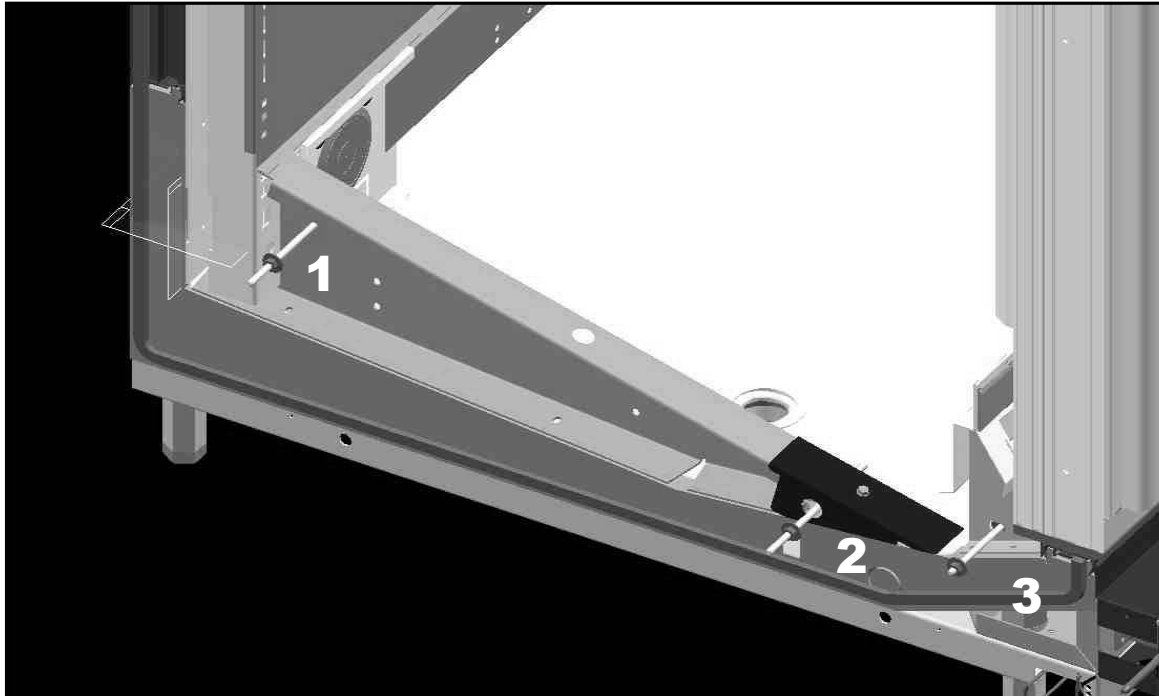

|  |                         |      |      |      |                                      |  |
|--|-------------------------|------|------|------|--------------------------------------|--|
| <b>COSTAN</b> TECHNICAL DOCUMENTATION          | CHAPTER REVISION STATUS |      |      |      | IN CONFORMITY WITH APPROVED ORIGINAL | PAGE: <b>6/6</b>                       |
|  | ORD.                    | DATE | ORD. | DATE |                                      | DATE of 1st ISSUE:<br><b>21.Jan.04</b> |
| PRODUCT: ELEPHANT GV                           | A                       |      | D    |      | ISSUED BY<br><b>MKT</b>              |  |
| CHAP. No. <b>10</b> DOC. no. <b>QSM000095E</b> | B                       |      | E    |      |                                      |  |
| CHAPTER: <b>MULTIPLEXING CABINETS</b>          | C                       |      | F    |      |                                      |  |

## ADJUST PLINTHS

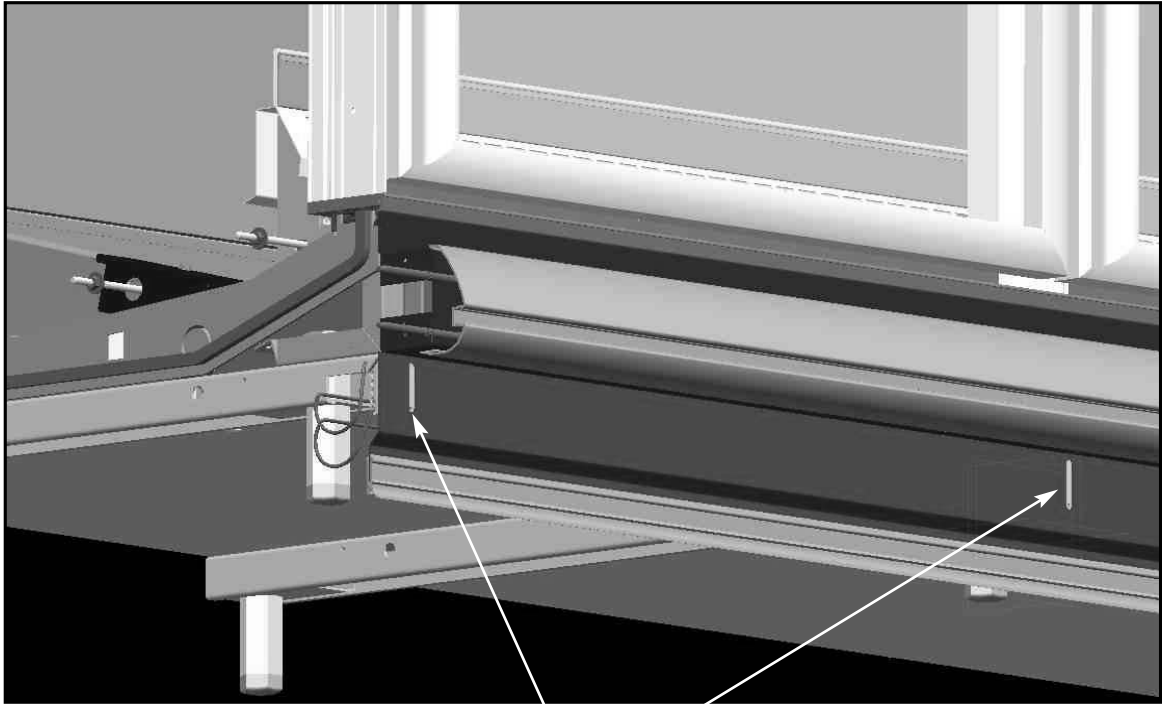

Adjust the height of front plinths using the bolts and slots existing on the plinths themselves.

|   |                         |      |      |      |                                      |  |
|---|-------------------------|------|------|------|--------------------------------------|--|
| <b>COSTAN</b> TECHNICAL DOCUMENTATION   | CHAPTER REVISION STATUS |      |      |      | IN CONFORMITY WITH APPROVED ORIGINAL | PAGE: <b>1/2</b>                       |
|   | ORD.                    | DATE | ORD. | DATE |                                      | DATE of 1st ISSUE:<br><b>21.Jan.04</b> |
| PRODUCT: ELEPHANT GV<br>CHAP. No. 11 N° DOC. QSM000095E<br>CHAPTER: PLACEMENT OF WATER DRAINS | A                       |      | D    |      | ISSUED BY<br><b>MKT</b>              |  |
|   | B                       |      | E    |      |                                      |  |
|   | C                       |      | F    |      |                                      |  |

## PLACEMENT OF WATER DRAINS

First position contemplated for the placement of the water drain.

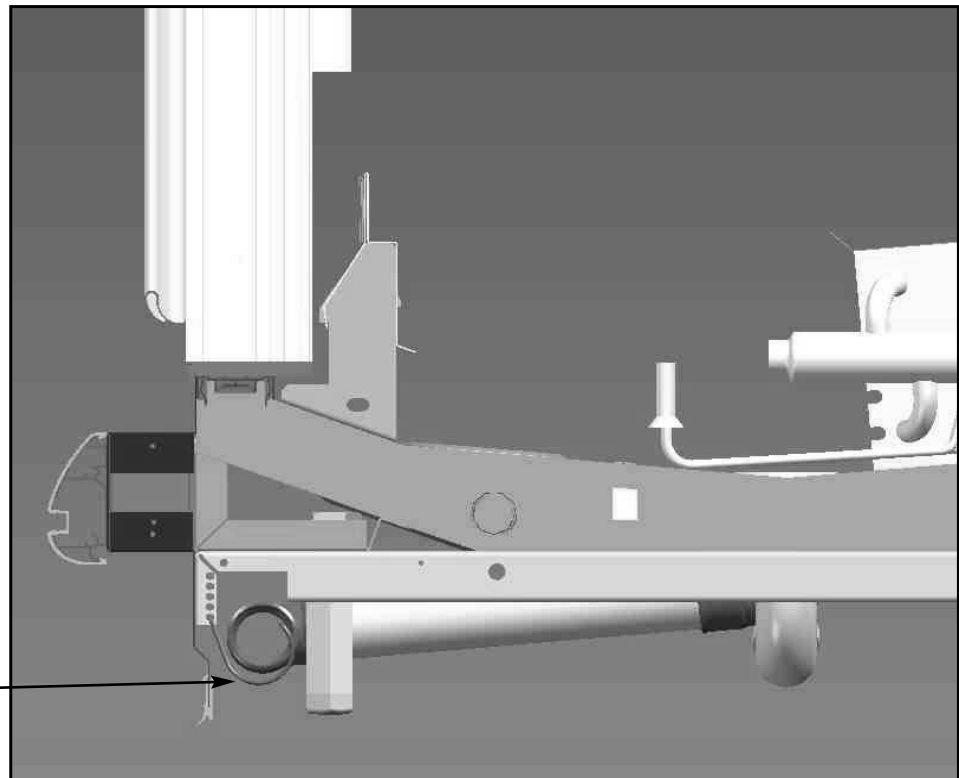
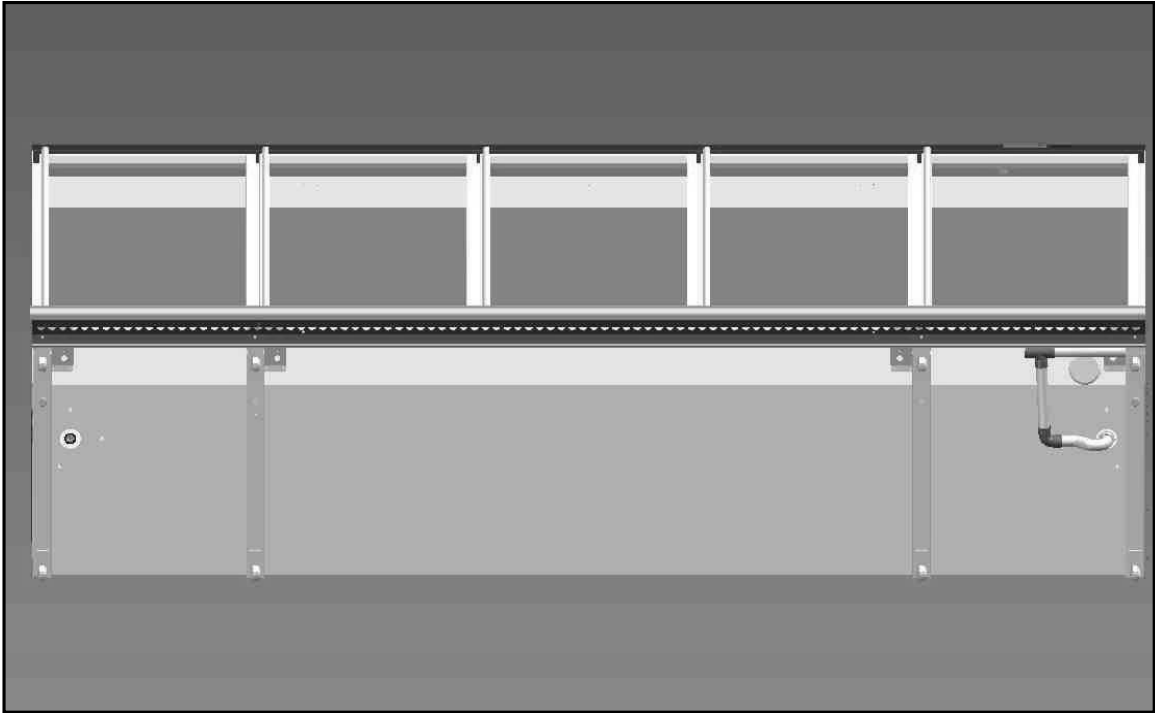

Adjustment of  
drain piping  
slope.

|                                       |                         |      |      |      |                                      |  |
|---------------------------------------|-------------------------|------|------|------|--------------------------------------|--|
| <b>COSTAN</b> TECHNICAL DOCUMENTATION | CHAPTER REVISION STATUS |      |      |      | IN CONFORMITY WITH APPROVED ORIGINAL | PAGE: <b>2/2</b>                       |
|                                       | ORD.                    | DATE | ORD. | DATE |                                      | DATE of 1st ISSUE:<br><b>21.Jan.04</b> |
| PRODUCT: ELEPHANT GV                  | A                       |      | D    |      | ISSUED BY<br><b>MKT</b>              |  |
| CHAP. No. 11      DOC. no. QSM000095E | B                       |      | E    |      |                                      |  |
| CHAPTER: PLACEMENT OF WATER DRAINS    | C                       |      | F    |      |                                      |  |

Second position contemplated for the placement of the water drain.

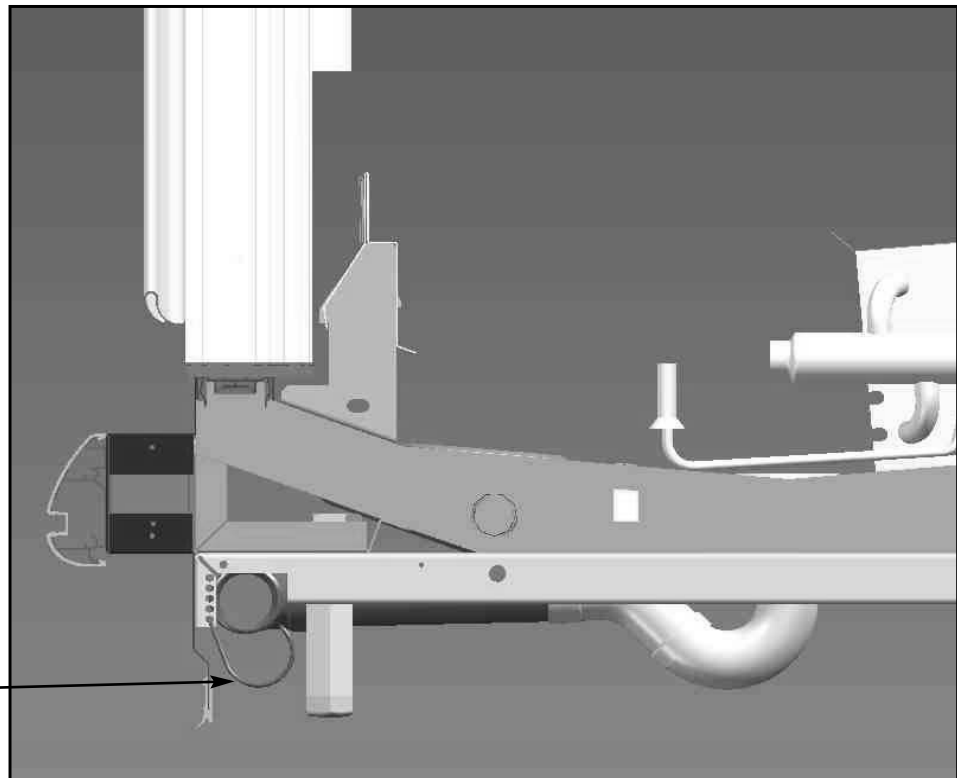
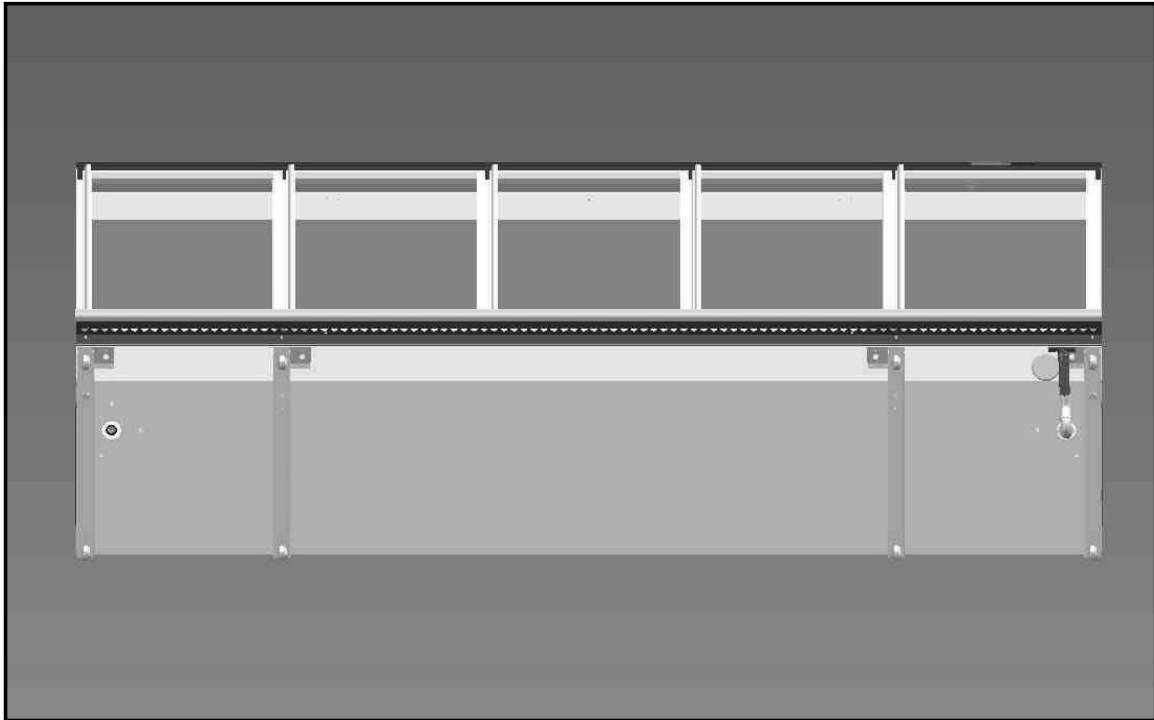

Adjustment of  
drain piping  
slope.

| ORD. | DATE | ORD. | DATE |
|------|------|------|------|
| A    |      | D    |      |
| B    |      | E    |      |
| C    |      | F    |      |

## INSTRUCTIONS FOR REVERSING THE DOOR-OPENING SWING SIDE

Diagram "A"

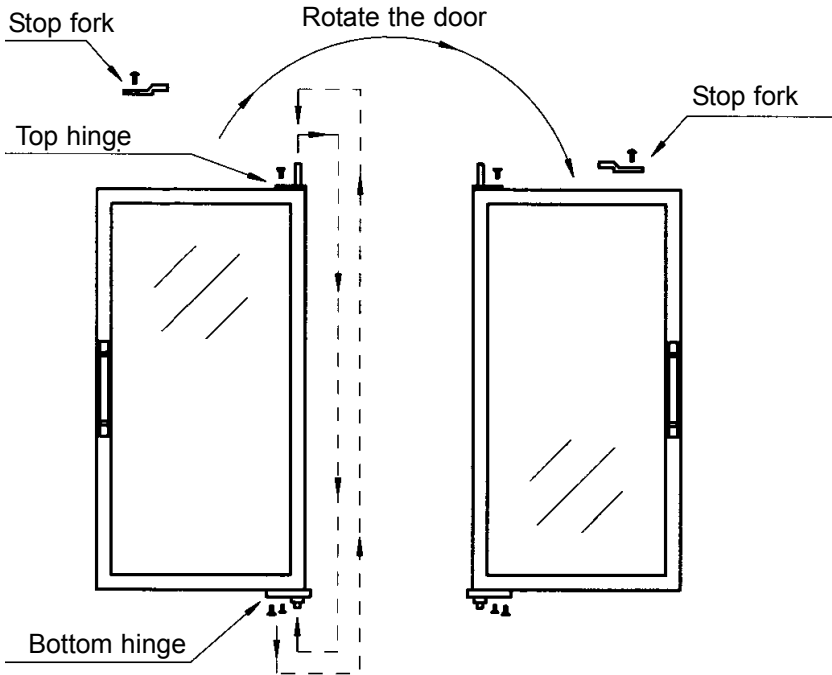
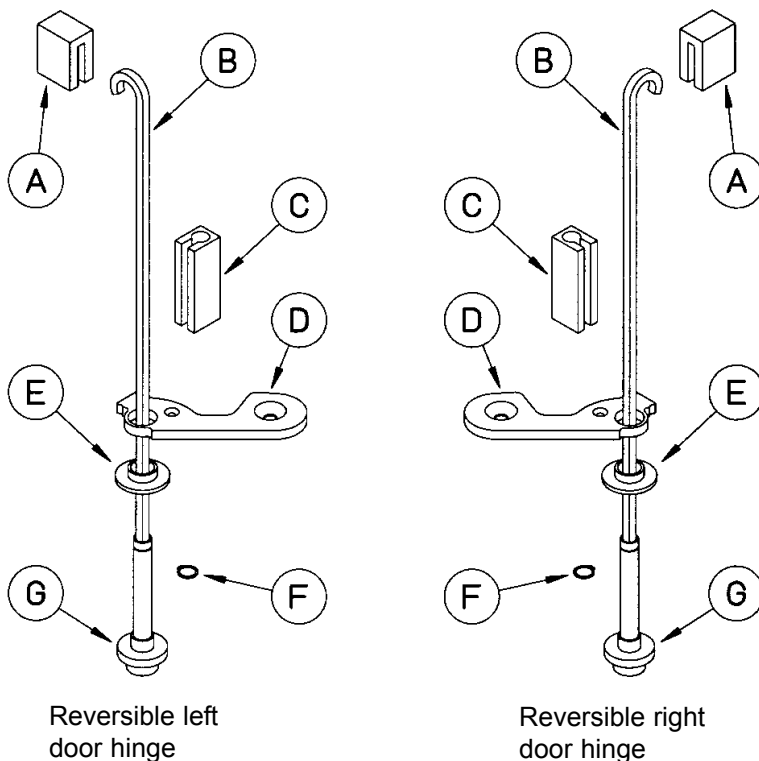

Diagram "B"



- 1) Unscrew the bottom hinge using a 2.5 and 4mm Allen key (see diagram "A") and remove it from the door.
- 2) Pull rotation-preventing block (A) off the hook-bent spring head (see diagram "B").
- 3) Remove stop ring (F) from its pin seat (G).
- 4) Slide block (C) off pin (G) and from square spring (B).
- 5) Slide platelet (D) from hook-bent square spring (B)
- 6) Pull bush (E) out of its seat on platelet (D) and put it in the corresponding hole on the opposite side.
- 7) Slide spring (B) and pin (G) into platelet (D) such that bush (E) rests on pin (G) (platelet position must now be reverse from previously).
- 8) Slide spring (B) and pin (G) into block (C) and secure them using ring (F)
- 9) Slide rotation-preventing block (A) on the hook-bent spring head (see diagram "B").
- 10) Unscrew the stop-fork and the top hinge and remove them from the door (see diagram "A").
- 11) Turn the door as shown in diagram "A", place the top and bottom hinges reversed to their previous position, and secure them using the same screws.
- 12) Place the stop-fork in its new position.
- 13) Install the door

|                                       |                         |      |      |      |                                      |   |
|---------------------------------------|-------------------------|------|------|------|--------------------------------------|---|
| <b>COSTAN</b> TECHNICAL DOCUMENTATION | CHAPTER REVISION STATUS |      |      |      | IN CONFORMITY WITH APPROVED ORIGINAL | PAGE: <b>1/1</b>                        |
|                                       | ORD.                    | DATE | ORD. | DATE |                                      | DATE of 1st ISSUE:<br><b>20.JULY.04</b> |
| PRODUCT: ELEPHANT GV                  | A                       |      | D    |      | ISSUED BY<br><b>MKT</b>              |   |
| CHAP. no. 13      DOC. no. QSM000095E | B                       |      | E    |      |                                      |   |
| CHAPTER: REVERSING THE FRAME BOTTOM   | C                       |      | F    |      |                                      |   |

## INSTRUCTIONS FOR REVERSING FRAME BOTTOM PLATES

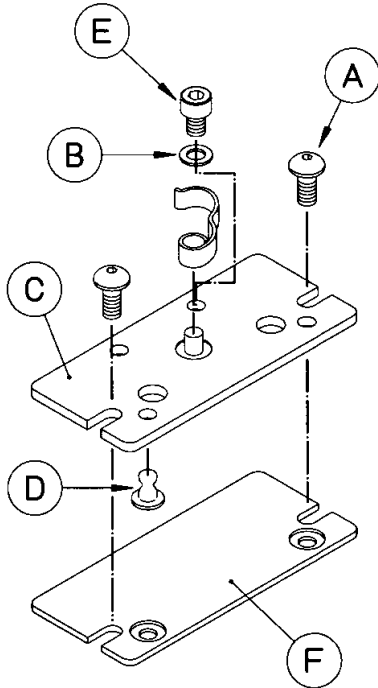

Bottom plates for left door

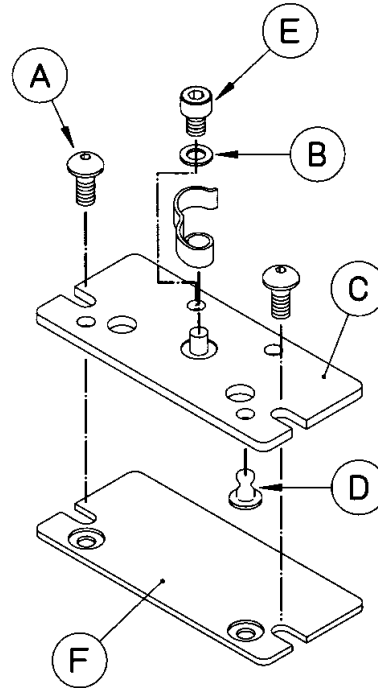

Bottom plates for right door

- 1) Unscrew screws (A) using a 4mm Allen key and remove the bottom plates from the frame.
- 2) Slide spring (B) and plate (C) off.
- 3) Move pin (D) and screw (E) and their respective washers to their new positions as shown in the drawing.
- 4) Put metal plate (C) back on nylon plate (F).
- 5) Remove the caps closing the plate-fastening holes on the frame and plug the previously used holes with them.
- 6) Place plates (C) and (F) in their new positions and secure them using screws (A).
- 7) Place door-stopping spring (B) in its new position as shown in the drawing.