

R404A

330 kW

50 Hz / 400 V

0.0K

10.0K

100%

T	SST: SCT:	A				B			
		-25.0°C 45.0°C				-10.0°C 45.0°C			
		Qo kW	Pe kW	COP %	-	Qo kW	Pe kW	COP %	-
		137.8	106.7	1.29	41.8	290	150.1	1.93	87.8
1	6G-30.2Y-40P	27.6	21.3	1.29	20.0	58.0	30.0	1.93	20.0
2	6G-30.2Y-40P	27.6	21.3	1.29	20.0	58.0	30.0	1.93	20.0
3	6G-30.2Y-40P	27.6	21.3	1.29	20.0	58.0	30.0	1.93	20.0
4	6G-30.2Y-40P	27.6	21.3	1.29	20.0	58.0	30.0	1.93	20.0
5	6G-30.2Y-40P	27.6	21.3	1.29	20.0	58.0	30.0	1.93	20.0

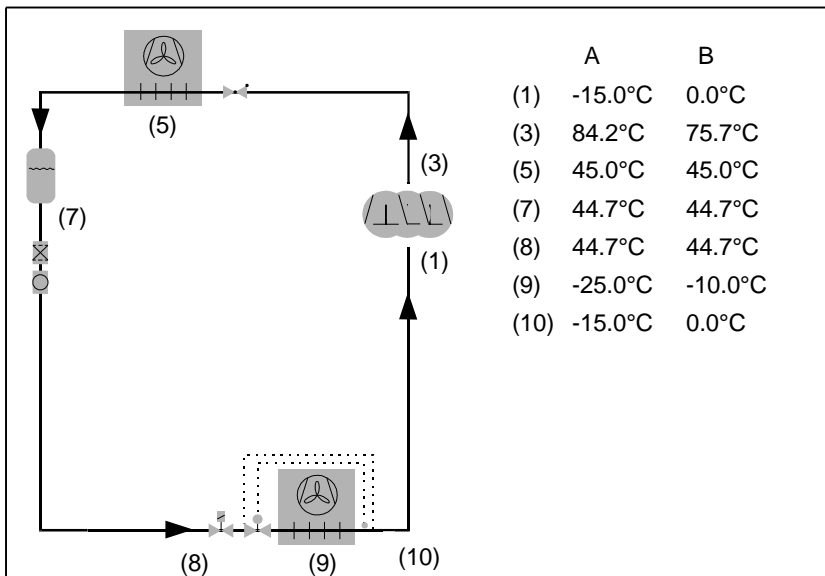

R404A

330 kW

50 Hz / 400 V

0.0K

10.0K

100%

T	SST: SCT:	A		B	
		-25.0°C 45.0°C		-10.0°C 45.0°C	
	-	137.8 kW		290 kW	
	-	137.8 kW		290 kW	
	-	41.8 %		87.8 %	
	-	245 kW		440 kW	
	.	106.7 kW		150.1 kW	
	(400V)	181.4 A		244 A	
	/	1.29		1.93	
	.	5362 kg/h		10275 kg/h	
		84.2 °C		75.7 °C	

6G-30.2Y-40P (#1)

R404A

330 kW

50 Hz / 400 V

0.0K

10.0K

100%

T	SST: SCT:	A	B
		-25.0°C 45.0°C	-10.0°C 45.0°C
	-	27.6 kW	58.0 kW
	- *	32.8 kW	63.5 kW
	-	27.6 kW	58.0 kW
	-	21.3 kW	30.0 kW
	(400V)	36.3 A	48.8 A
	/	380-420V	380-420V
	/ *	1.29	1.93
		1.54	2.12
		1072 kg/h	2055 kg/h
		Standard	Standard
		84.2 °C	75.7 °C

ASERCOM

* EN12900 (20° , 0)

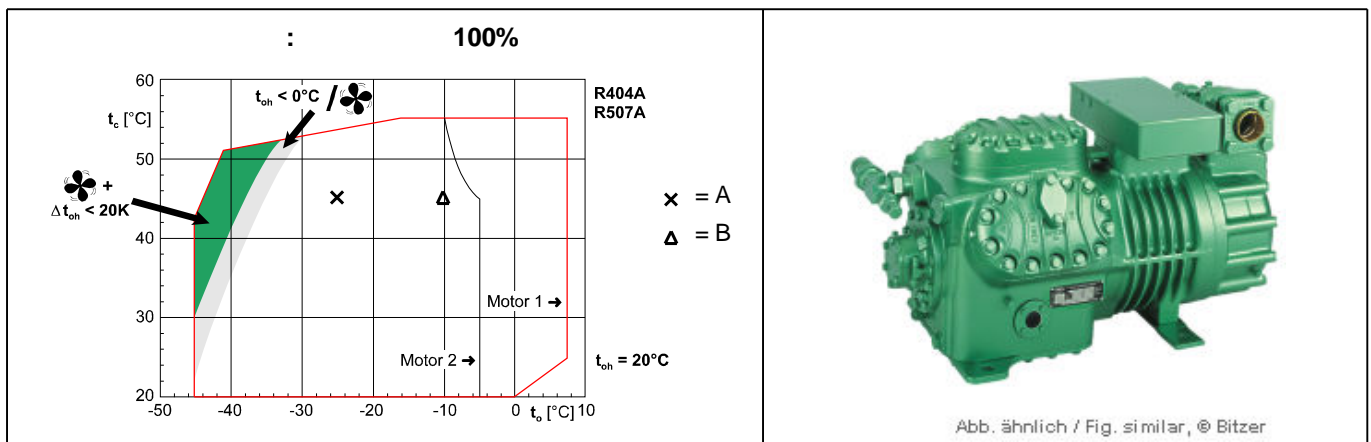

6G-30.2Y-40P (#1)

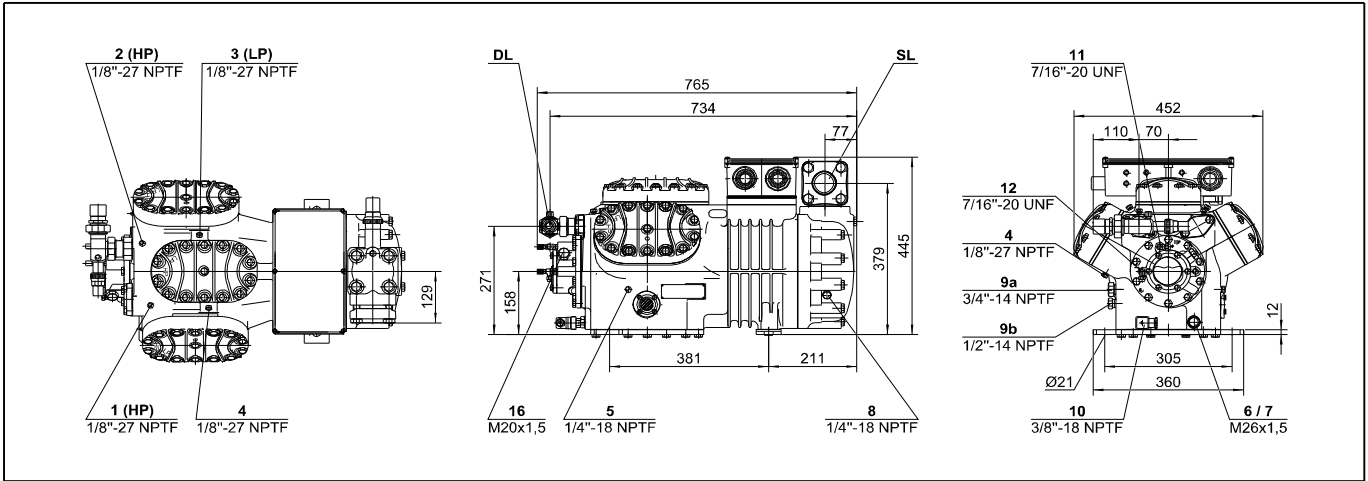

- (1450 / 50)
 - (1750 / 60)
 (.)
 ()
 (/)
 -
 R134a/R404A/R507A/R407C
 R22 (R12/R502)
 R290/R1270

126,8 m /h
 153,0 m /h
 6 x 75 mmx 55 mm
 380-420V PW-3-50 Hz
 53.0 A
 50/50
 135.0 A Y / 220.0 A YY
 228 kg
 19 / 28 bar
 54 mm- 2 1/8"
 35 mm- 1 3/8"
 R 3/4"
 tc<55°C: BSE32 / tc>55°C: BSE55 (Option)
 B5.2 (Standard)
 Clavus G68 (Standard)
 4,75 dm
 140 W (Option)
 MP54 (Option), Delta P (Option, not for R290/R1270)
 Option
 Option
 SE-B2
 IP54 (Standard), IP66 (Option)
 Option
 100-66-33% (Option)
 Option
 Option
 Standard
 (-10°C/45°C) @50 83,5 dB(A) @ 50Hz
 (-35°C/40°C) @50 90,5 dB(A) @ 50Hz
 @1 (-10°C/45°C) @50 75,5 dB(A) @ 50Hz
 @1 (-35°C/40°C) @50 82,5 dB(A) @ 50Hz

CIC

6G-30.2Y-40P (#2)

R404A

330 kW

50 Hz / 400 V

0.0K

10.0K

100%

T	SST: SCT:	A	B
		-25.0°C 45.0°C	-10.0°C 45.0°C
	-	27.6 kW	58.0 kW
	- *	32.8 kW	63.5 kW
	-	27.6 kW	58.0 kW
	-	21.3 kW	30.0 kW
	(400V)	36.3 A	48.8 A
	/	380-420V	380-420V
	/ *	1.29	1.93
		1.54	2.12
		1072 kg/h	2055 kg/h
		Standard	Standard
		84.2 °C	75.7 °C

ASERCOM

* EN12900 (20° , 0)

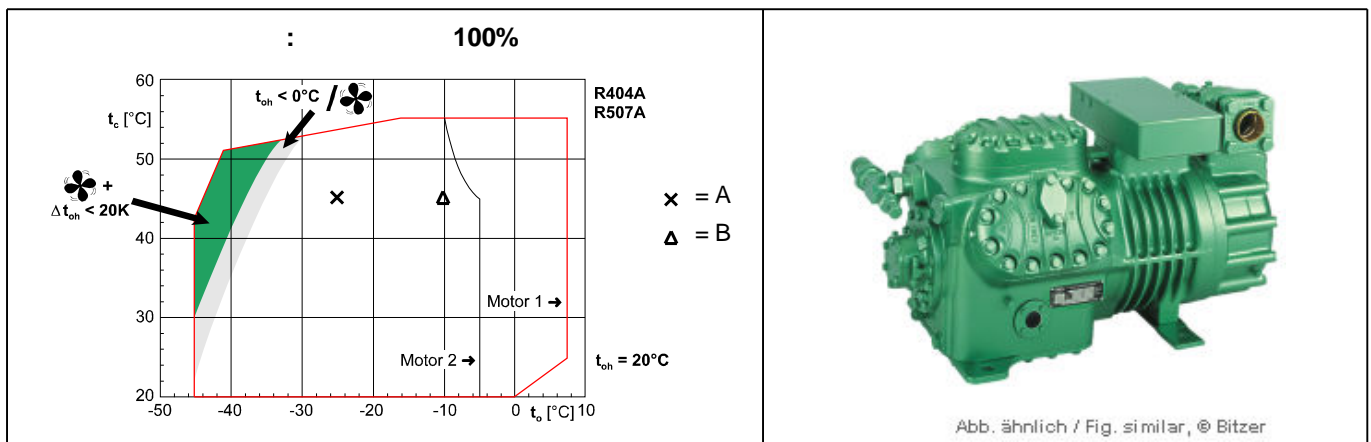

6G-30.2Y-40P (#2)

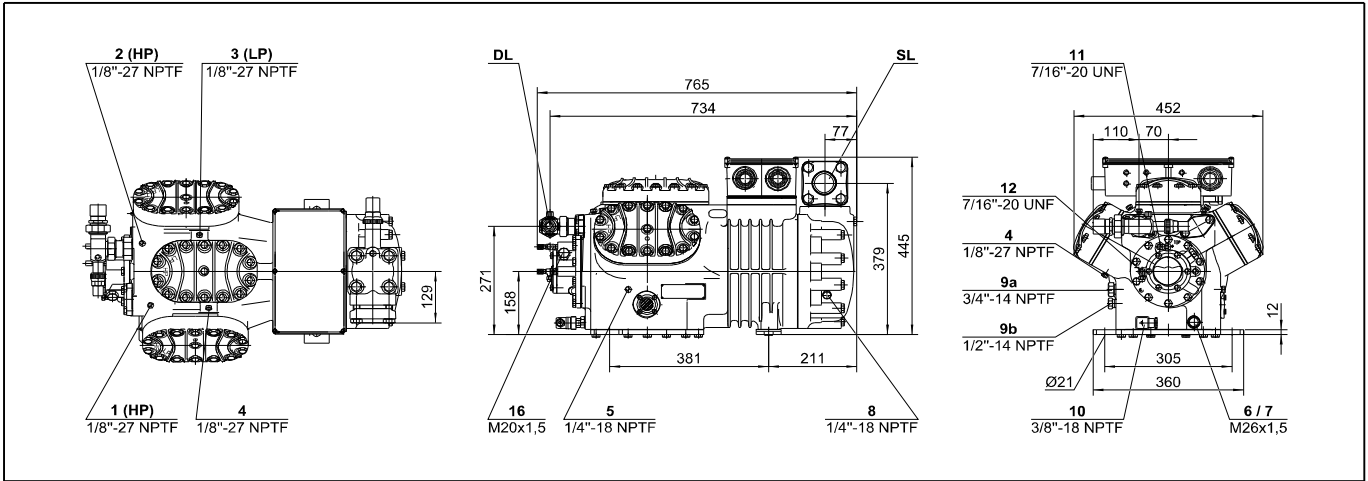

- (1450 / 50)
 - (1750 / 60)
 (.)
 ()
 (/)
 -
 R134a/R404A/R507A/R407C
 R22 (R12/R502)
 R290/R1270

126,8 m /h
 153,0 m /h
 6 x 75 mm x 55 mm
 380-420V PW-3-50 Hz
 53.0 A
 50/50
 135.0 A Y / 220.0 A YY
 228 kg
 19 / 28 bar
 54 mm- 2 1/8"
 35 mm- 1 3/8"
 R 3/4"
 tc<55°C: BSE32 / tc>55°C: BSE55 (Option)
 B5.2 (Standard)
 Clavus G68 (Standard)
 4,75 dm
 140 W (Option)
 MP54 (Option), Delta P (Option, not for R290/R1270)
 Option
 Option
 SE-B2
 IP54 (Standard), IP66 (Option)
 Option
 100-66-33% (Option)
 Option
 Option
 Standard
 (-10°C/45°C) @50 83,5 dB(A) @ 50Hz
 (-35°C/40°C) @50 90,5 dB(A) @ 50Hz
 @1 (-10°C/45°C) @50 75,5 dB(A) @ 50Hz
 @1 (-35°C/40°C) @50 82,5 dB(A) @ 50Hz

CIC

6G-30.2Y-40P (#3)

R404A

330 kW

50 Hz / 400 V

0.0K

10.0K

100%

T	SST: SCT:	A	B
		-25.0°C 45.0°C	-10.0°C 45.0°C
	-	27.6 kW	58.0 kW
	- *	32.8 kW	63.5 kW
	-	27.6 kW	58.0 kW
	-	21.3 kW	30.0 kW
	(400V)	36.3 A	48.8 A
	/	380-420V	380-420V
	/ *	1.29	1.93
		1.54	2.12
		1072 kg/h	2055 kg/h
		Standard	Standard
		84.2 °C	75.7 °C

ASERCOM

* EN12900 (20° , 0)

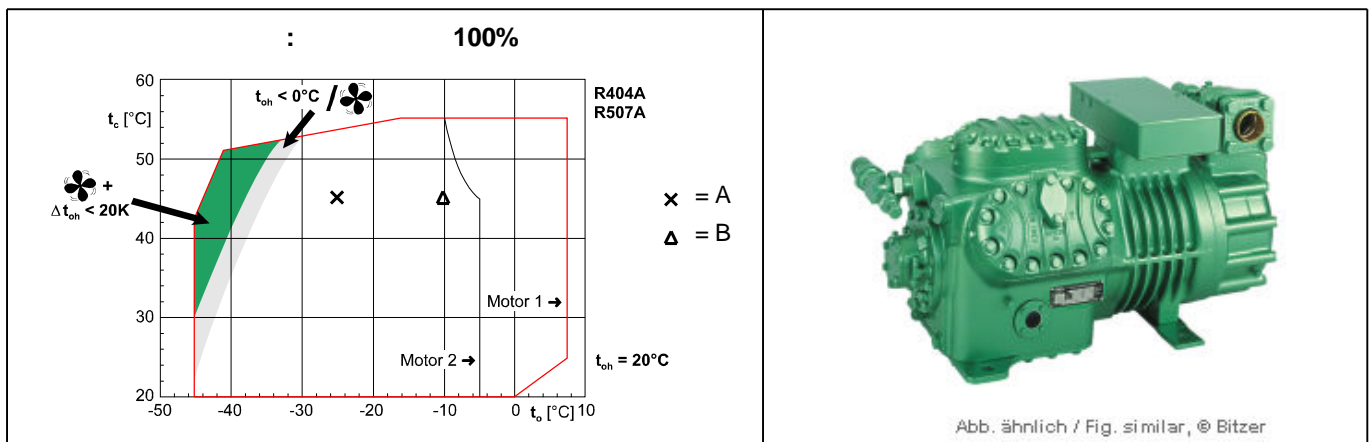

6G-30.2Y-40P (#3)

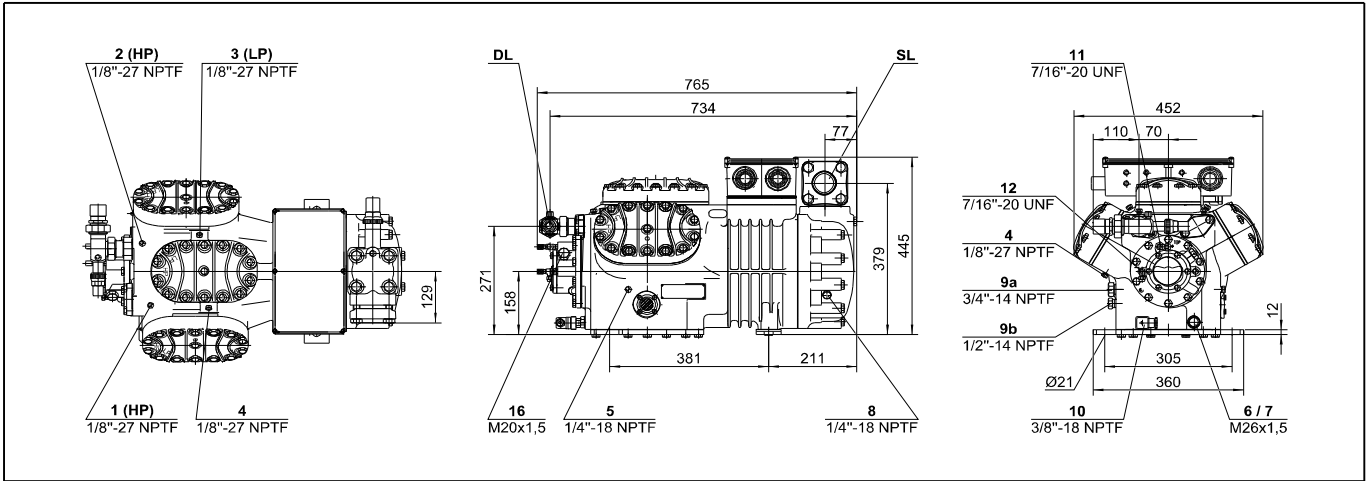

- (1450 / 50)
 - (1750 / 60)
 (.)
 ()
 (/)
 -
 R134a/R404A/R507A/R407C
 R22 (R12/R502)
 R290/R1270

126,8 m /h
 153,0 m /h
 6 x 75 mmx 55 mm
 380-420V PW-3-50 Hz
 53.0 A
 50/50
 135.0 A Y / 220.0 A YY
 228 kg
 19 / 28 bar
 54 mm- 2 1/8"
 35 mm- 1 3/8"
 R 3/4"
 tc<55°C: BSE32 / tc>55°C: BSE55 (Option)
 B5.2 (Standard)
 Clavus G68 (Standard)
 4,75 dm
 140 W (Option)
 MP54 (Option), Delta P (Option, not for R290/R1270)
 Option
 Option
 SE-B2
 IP54 (Standard), IP66 (Option)
 Option
 100-66-33% (Option)
 Option
 Option
 Standard
 (-10°C/45°C) @50 83,5 dB(A) @ 50Hz
 (-35°C/40°C) @50 90,5 dB(A) @ 50Hz
 @1 (-10°C/45°C) @50 75,5 dB(A) @ 50Hz
 @1 (-35°C/40°C) @50 82,5 dB(A) @ 50Hz

CIC

6G-30.2Y-40P (#4)

R404A

330 kW

50 Hz / 400 V

0.0K

10.0K

100%

T	SST: SCT:	A	B
		-25.0°C 45.0°C	-10.0°C 45.0°C
	-	27.6 kW	58.0 kW
	- *	32.8 kW	63.5 kW
	-	27.6 kW	58.0 kW
	-	21.3 kW	30.0 kW
	(400V)	36.3 A	48.8 A
	/	380-420V	380-420V
	/ *	1.29	1.93
		1.54	2.12
		1072 kg/h	2055 kg/h
		Standard	Standard
		84.2 °C	75.7 °C

ASERCOM

* EN12900 (20° , 0)

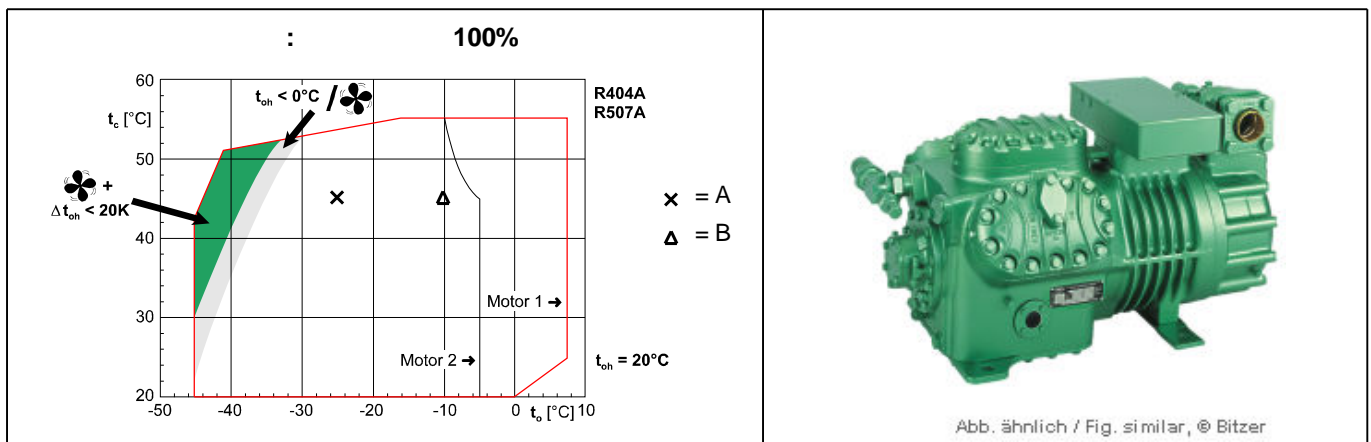

6G-30.2Y-40P (#4)

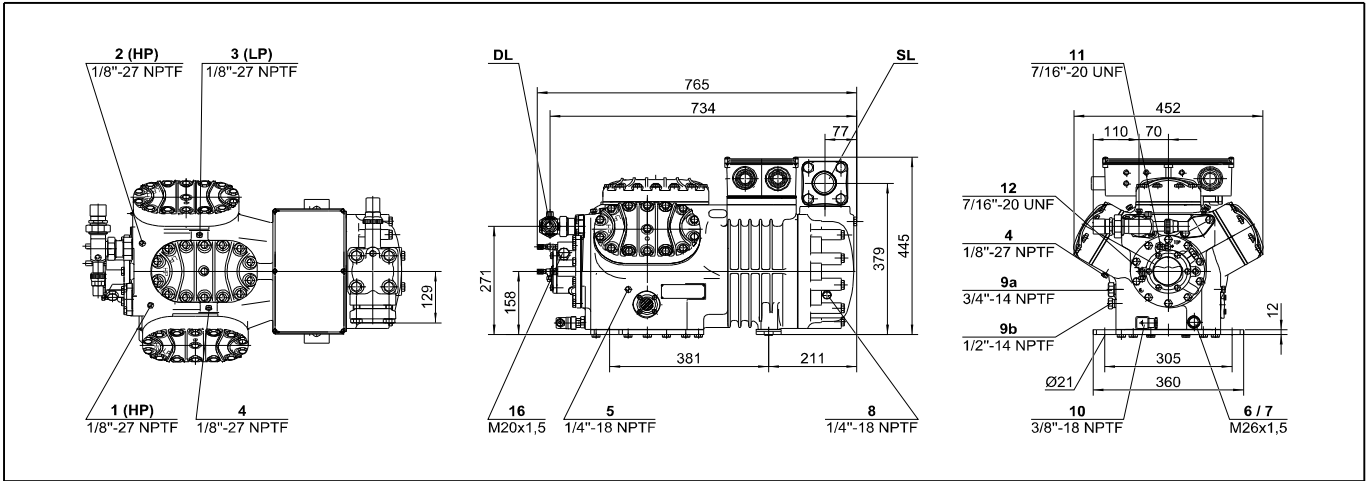

- (1450 / 50)
 - (1750 / 60)
 (.)
 ()
 (/)
 -
 R134a/R404A/R507A/R407C
 R22 (R12/R502)
 R290/R1270

126,8 m /h
 153,0 m /h
 6 x 75 mm x 55 mm
 380-420V PW-3-50 Hz
 53.0 A
 50/50
 135.0 A Y / 220.0 A YY
 228 kg
 19 / 28 bar
 54 mm- 2 1/8"
 35 mm- 1 3/8"
 R 3/4"
 tc<55°C: BSE32 / tc>55°C: BSE55 (Option)
 B5.2 (Standard)
 Clavus G68 (Standard)
 4,75 dm
 140 W (Option)
 MP54 (Option), Delta P (Option, not for R290/R1270)
 Option
 Option
 SE-B2
 IP54 (Standard), IP66 (Option)
 Option
 100-66-33% (Option)
 Option
 Option
 Option
 Standard
 (-10°C/45°C) @50 83,5 dB(A) @ 50Hz
 (-35°C/40°C) @50 90,5 dB(A) @ 50Hz
 @1 (-10°C/45°C) @50 75,5 dB(A) @ 50Hz
 @1 (-35°C/40°C) @50 82,5 dB(A) @ 50Hz

CIC

6G-30.2Y-40P (#5)

R404A

330 kW

50 Hz / 400 V

0.0K

10.0K

100%

T	SST: SCT:	A	B
		-25.0°C 45.0°C	-10.0°C 45.0°C
	-	27.6 kW	58.0 kW
	- *	32.8 kW	63.5 kW
	-	27.6 kW	58.0 kW
	-	21.3 kW	30.0 kW
	(400V)	36.3 A	48.8 A
	-	380-420V	380-420V
	/	1.29	1.93
	/ *	1.54	2.12
	-	1072 kg/h	2055 kg/h
	-	Standard	Standard
	-	84.2 °C	75.7 °C

ASERCOM

* EN12900 (20° , 0)

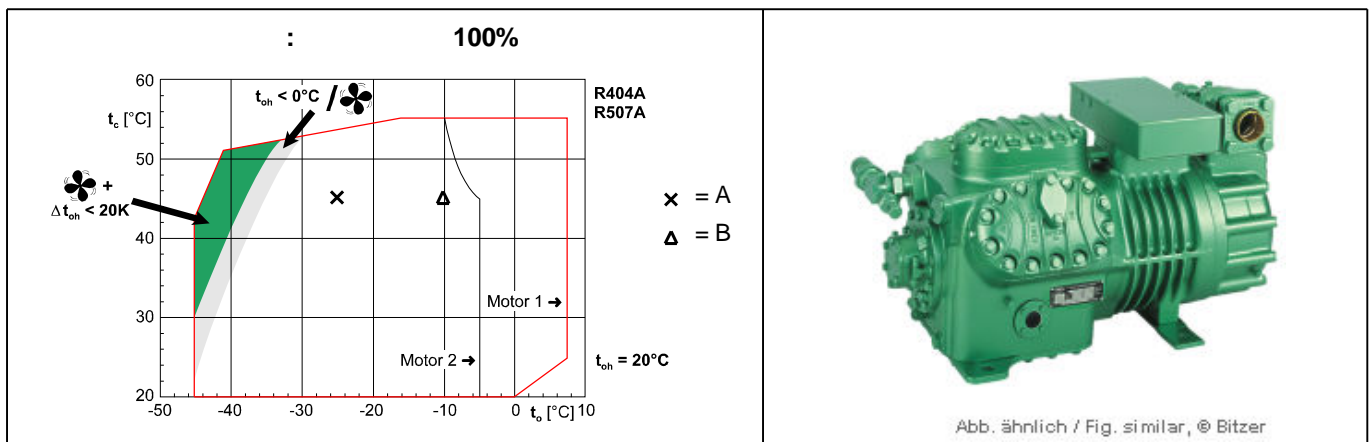

6G-30.2Y-40P (#5)

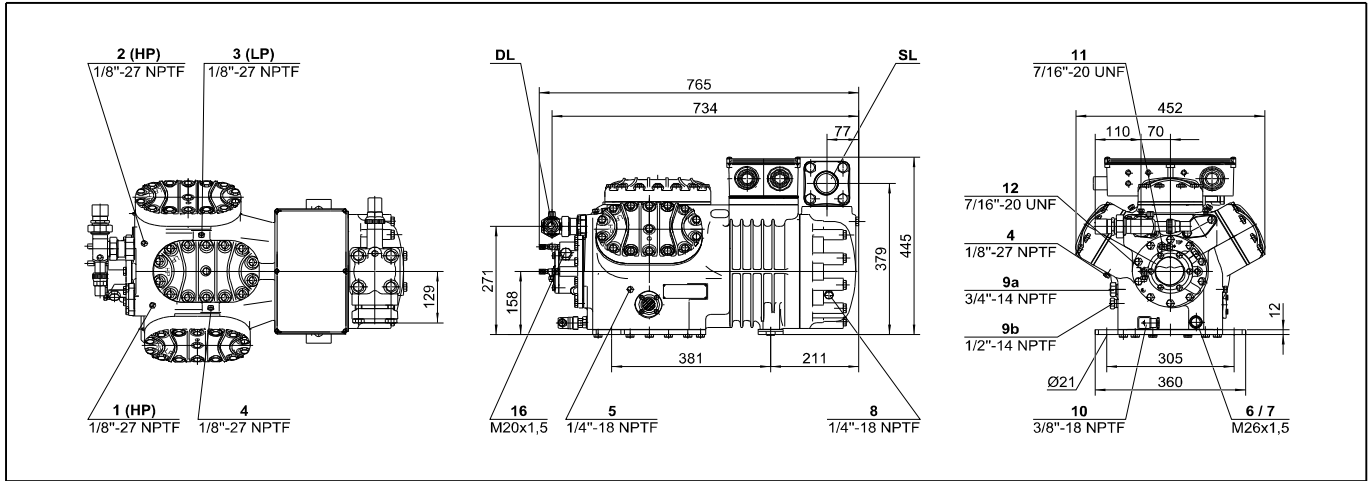

- (1450 / 50)
 - (1750 / 60)
 (.)
 ()
 (/)
 -
 R134a/R404A/R507A/R407C
 R22 (R12/R502)
 R290/R1270

126,8 m /h
 153,0 m /h
 6 x 75 mm x 55 mm
 380-420V PW-3-50 Hz
 53.0 A
 50/50
 135.0 A Y / 220.0 A YY
 228 kg
 19 / 28 bar
 54 mm- 2 1/8"
 35 mm- 1 3/8"
 R 3/4"
 tc<55°C: BSE32 / tc>55°C: BSE55 (Option)
 B5.2 (Standard)
 Clavus G68 (Standard)
 4,75 dm
 140 W (Option)
 MP54 (Option), Delta P (Option, not for R290/R1270)
 Option
 Option
 SE-B2
 IP54 (Standard), IP66 (Option)
 Option
 100-66-33% (Option)
 Option
 Option
 Standard
 (-10°C/45°C) @50 83,5 dB(A) @ 50Hz
 (-35°C/40°C) @50 90,5 dB(A) @ 50Hz
 @1 (-10°C/45°C) @50 75,5 dB(A) @ 50Hz
 @1 (-35°C/40°C) @50 82,5 dB(A) @ 50Hz

CIC

1 = , 4TCS-12.2 12 . . .
 (R22, R407C), (R404A, R507A, R22),
 R134a

2 = , 4TCS-8.2 8 . . .
 (R404A, R507A, R22), R134a.
 " "

(2 0173SH 4C1145SL), R22:

Standard SL(A) =

Varicool SL(B) =

4VCS-6.2 (4Z-5.2) 6F-40.2 R22:

CIC-

ASERCOM:

ASERCOM-

Bitzer

ASERCOM

www.asercom.org.

R404A/R507A

< -20

" / ". " 5% (HR).

(c HR)".

50 (IP- 60) R404A.

1

"

"

" / ":

1 (HP)

2 (HP)

3 (LP)

4 | - :
 4b CIC-

5
 6 ()

7
 8 ()

9 ,

9a

9b

10

11

+

12

-

13

16

"Delta-P"